

Motor

Engine
Moteur
Motore
Motor
Motor
Motor

11 Engine

| Specifications | Page | 11-0/3 |
|--|------|--------|
| 1100005 Diagnosis with BMW program /digital tester | | 00/1 |
| 039 Checking compression of all cylinders | | 00/23 |
| 050 Removing and installing engine | | 00/23 |
| 1111160 Renew distributor shaft bearings | | 11/1 |
| 1112000 Removing and installing cylinder head cover | | 12/1 |
| 100 Removing and installing cylinder head | | 12/1 |
| 101 Renewing cylinder head gasket | | 12/7 |
| 240 Renewing radial seal in timing case cover | | 12/7 |
| 561 Renewing one valve guide | | 12/8 |
| 607 Machining valve seats and valves | | 12/9 |
| 719 Grinding cylinder head mating surface | | 12/9 |
| 729 Cylinder head water leak test | | 12/9 |
| 1113000 Removing and installing oil sump | | 13/1 |
| 1114175 Removing and installing front end cover | | 14/1 |
| 180 Renewing radial seals in end cover | | 14/3 |
| 611 Renewing radial seal in end cover (clutch end) | | 14/3 |
| 1121000 Removing and installing crankshaft | | 21/1 |
| 501 Renewing crankshaft | | 21/2 |
| 571 Renewing needle sleeve in crankshaft | | 21/3 |
| 1122000 Removing and installing flywheel | | 22/1 |
| 051 Renewing torque converter drive plate | | 22/1 |
| 541 Renewing starter gear ring | | 22/2 |
| 1124521 Renewing all connecting rods | | 24/1 |
| 1125000 Removing and installing all pistons | | 25/1 |
| 651 Renewing rings of one piston | | 25/3 |
| 1131000 Removing and installing camshaft | | 31/1 |
| 100 Tightening toothed belt | | 31/1 |
| 110 Removing and installing toothed belt | | 31/2 |
| 1133020 Removing and installing rocker arm shafts | | 33/1 |
| 031 Renewing all rocker arms | | 33/2 |
| 1134004 Adjusting valve clearance | | 34/1 |
| 509 Checking all valves for leaks | | 34/1 |
| 550 Removing and installing valves | | 34/1 |
| 1135020 Removing and installing intermediate distributor shaft | | 35/1 |
| 1141000 Removing and installing oil pump | | 41/1 |
| 110 Removing and installing safety valve | | 41/1 |
| 1151000 Removing and installing water pump | | 51/1 |
| 502 Disassembling and assembling water pump | | 51/2 |
| 1153000 Removing and installing coolant thermostat | | 53/1 |
| 081 Renewing temperature transmitter | | 53/1 |
| 1161000 Removing and installing/sealing intake line and carburetor | | 61/1 |
| 050 Removing and installing intake air collector | | 61/3 |
| 051 Renewing intake air collector | | 61/5 |
| 1174051 Renewing thermo valve | | 74/1 |

Engine Specifications

| Engine | Specifications | |
|--|----------------------------------|--------------------------------|
| Model | a) 320/6 b) 320/6 A | a) 323 i b) 323 i A * |
| 11 00 ... Engine, general | | |
| Bore | 80 (3.15) | 80 (3.15) |
| Stroke | 66 (2.60) | 76.8 (3.02) |
| Stroke/bore ratio | 0.825 | 0.96 |
| Displacement, fiscal | | |
| effective | 1977 (120.64) 1990 (121.44) | 2291 (139.81) 2316 (141.33) |
| Compression ratio | 9.2 : 1 | 9.5 : 1 |
| Max. effective output at engine speed | 90 (122.4) ¹⁾ 6000 | 105 (142.8) 5800 |
| Governor cutout speed | 6600 ± 150 | 6600 ± 150 |
| Max. permitted engine speed | 6400 | 6400 |
| Max. continuous engine speed | 6000 | 6000 |
| Max. torque at engine speed | 160 (16.3, 118.0) 4000 | 190 (19.4, 140.1) 4500 |

*) Version for Sweden

¹⁾ 88.2 kW (120 bhp) on Austrian Version

Specifications

Engine

| Model | 320/6 320/6 A | 323 i 323 i A *) | | | |
|---|------------------------------------|---|---------------------------|---------------------------------|---------------------|
| 1100 ... Engine - general (continued) | | | | | |
| Power/weight ratio ready for road, tank full (at unladen weight) | kg/kW (kg/bhp) (bhp/ton) | a) 12.4 9.1 (111.7) | b) 12.5 9.2 (110.4) | a) 10.8 7.9 (128.6) | b) |
| fully loaded, incl. luggage (at permissible gross weight) | kg/kW kg/bhp (bhp/ton) | a) 17.2 12.7 (80.0) | b) | a) 14.9 11.0 (92.3) | b) |
| Mean piston speed at engine speed | m/s (ft/min) 1/min | 13.2 (2598) 6000 | | | 14.8 (2913) 5800 |
| Compression pressure (gauge) - test procedure: measure with a suitable compression tester; battery fully charged, engine at normal operating temperature, throttle fully open, engine turned over at starting speed Compression: | good above normal poor below | bar (lb/in ²) bar (lb/in ²) bar (lb/in ²) | 11.0 (156.5) | 10.0 ... 11.0 (142.2 ... 156.5) | 10.0 (142.2) |

*) Version for Sweden

Specifications

Engine

| Model | a) 320/6 b) 320/6 A | a) 323 i b) 323 i A *) |
|--|--|-------------------------------|
| 1100 ... Engine – general (continued) | | |
| Fuel consumption by DIN 70030 standard test method ¹⁾ | a) 9.5 b) 10.4 29.7 27.2 24.8 22.6 | a) 9.2 b) ... 30.7 25.6 |
| 1111 ... Engine block | | |
| Cylinders | | |
| Bore – standard size | 80.015 ± 0.005 (3.1502 ± 0.0002) | |
| Bore – intermediate oversize | 80.095 ± 0.005 (3.1533 ± 0.0002) | |
| Bore – 1st rebore oversize | 80.265 ± 0.005 (3.1600 ± 0.0002) | |
| Bore – 2nd rebore oversize | 80.515 ± 0.005 (3.1699 ± 0.0002) | |
| Surface roughness | μl 3 ... 4 | |
| Permissible out-of-roundness of cylinder bore | 0.01 ... 0.02 (0.0004 ... 0.0008) | |
| Permissible cylinder bore conicity | 0.01 (0.0004) | |
| Permissible angular deviation of cylinder centerline from a line perpendicular to bearing bore | 0° 0.5' | |
| Permissible total wear allowance at piston and cylinder | 0.10 ... 0.15 (0.004 ... 0.006) | |

*) Version for Sweden

¹⁾ See Page 11–0/39

Specifications

| Engine | 320/6 320/6 A | 323 i 323 i A *) |
|---|--|---------------------|
| 1112 . . . Cylinder head | | |
| Rocker shaft bore dia. | 17.5 $\begin{smallmatrix} + 0.043 \\ 0 \end{smallmatrix}$ (0.6890 $\begin{smallmatrix} + 0.0017 \\ 0 \end{smallmatrix}$) | |
| Rocker shaft installed clearance | 0.016 . . . 0.077 (0.0006 . . . 0.0030) | |
| Valve guide bore dia. | 13 $\begin{smallmatrix} + 0.018 \\ 0 \end{smallmatrix}$ (0.5118 $\begin{smallmatrix} + 0.0007 \\ 0 \end{smallmatrix}$) | |
| Oversizes | 13.1/13.2/13.3 (0.5157/0.5197/0.5236) | |
| Shrink fit for valve guide | 0.015 . . . 0.044 (0.0006 . . . 0.0017) | |
| Temperature to which cylinder head must be heated °C (°F) | 220 . . . 250 (428 . . . 482) | |
| Bore for valve seat ring ¹⁾ | | |
| Inlet | 42.00 $\begin{smallmatrix} + 0.025 \\ 0 \end{smallmatrix}$ (1.6535 $\begin{smallmatrix} + 0.0010 \\ 0 \end{smallmatrix}$) | |
| Exhaust | 37.50 $\begin{smallmatrix} + 0.025 \\ 0 \end{smallmatrix}$ (1.4764 $\begin{smallmatrix} + 0.0010 \\ 0 \end{smallmatrix}$) | |
| Shrink fit ²⁾ for valve seat ring | 0.10 . . . 0.15 (0.004 . . . 0.006) | |

*) Version for Sweden

1) Note shrink fit dimension for oversize bore in cylinder head

2) With cylinder head heated to 220 . . . 250 °C (428 . . . 482 °F). Chill valve seat ring to app. -70 °C (-94 °F)

Specifications

| Engine | | | 320/6 320/6 A | 323 i 323 i A *) |
|-----------------------------|---------|---------|---------------------------------|---------------------------------|
| 1112 . . . Valve seat rings | | | | |
| External diameter | Inlet | mm (in) | 42.15 - 0.009 (1.6594 - 0.0004) | 42.15 - 0.025 (1.6594 - 0.0010) |
| | Exhaust | mm (in) | 37.65 - 0.009 (1.4828 - 0.0004) | 37.65 - 0.025 (1.4828 - 0.0010) |
| Oversizes ¹⁾ | Inlet | mm (in) | 42.35 - 0.025 (1.6673 - 0.0010) | 42.35 - 0.009 (1.6673 - 0.0004) |
| | Exhaust | mm (in) | 42.55 - 0.009 (1.6752 - 0.0004) | 42.55 - 0.025 (1.6752 - 0.0010) |
| Valve seat angle | | deg. | 37.85 - 0.009 (1.4902 - 0.0004) | 37.85 - 0.025 (1.4902 - 0.0010) |
| Extl. correction angle | | deg. | 38.05 - 0.009 (1.4980 - 0.0004) | 38.05 - 0.025 (1.4980 - 0.0010) |
| Valve seat width | Inlet | mm (in) | | 1.5 (0.059) |
| | Exhaust | mm (in) | | 1.65 (0.065) |

*) Version for Sweden

1) Note shrink fit dimension for oversize bore in cylinder head

Specifications

| Engine | 320/6 320/6 A | 323 i 323 i A *) |
|--|------------------|--|
| Model | | |
| 11 12 . . . Valve guide | | |
| Overall length | mm (in) | 45 (1.772) |
| External diameter | mm (in) | 13.0 + 0.044 + 0.0017 + 0.033 (0.5118 + 0.0013) |
| Valve guide intl. dia. (in cylinder head) | mm (in) | 7 + 0.015 + 0.0006 0 (0.2756 + 0.0006) |
| Oversizes | mm (in) | 13.1/13.2/13.3 (0.5157/0.5197/0.5236) |
| Valve guide projection in (cylinder head) | mm (in) | 14.5 ± 0.5 (0.5709 ± 0.0197) |
| 11 21 . . . Crankshaft with bearings | | |
| Crankshaft | | |
| Bearing bore dia. in crankcase | mm (in) | 65 + 0.010 + 0.0004 0 (2.5591 + 0.0004) |
| | red | |
| | blue | 65 + 0.019 + 0.0007 + 0.010 (2.5591 + 0.0004) |

*) Version for Sweden

Specifications

Engine

| Model | 320/6 320/6 A | 323 i 323 i A *) |
|---|------------------|---|
| 1121 . . . Crankshaft with bearings (continued) | | |
| Regrind stages – main bearing journals | mm (in) | |
| Standard | red | 60 – 0.010 (2.3622 – 0.0004) – 0.020 (– 0.0008) |
| | blue | 60 – 0.020 (2.3622 – 0.0008) – 0.029 (– 0.0011) |
| 1st regrind | red | 59.75 – 0.010 (2.3524 – 0.0004) – 0.020 (– 0.0008) |
| | blue | 59.75 – 0.020 (2.3524 – 0.0008) – 0.029 (– 0.0011) |
| 2nd regrind | red | 59.50 – 0.010 (2.3425 – 0.0004) – 0.020 (– 0.0008) |
| | blue | 59.50 – 0.020 (2.3425 – 0.0008) – 0.029 (– 0.0011) |
| Bearing shell thicknesses | | |
| Standard | red | 2.50 – 0.010 (0.0984 – 0.0004) – 0.020 (– 0.0008) |
| | blue | 2.51 – 0.010 (0.0988 – 0.0004) – 0.020 (– 0.0008) |

*) Version for Sweden

Specifications

| Engine | 320/6 320/6 A | | 323 i 323 i A *) |
|---|------------------|--|---------------------|
| Model | | | |
| 11 21 ... Crankshaft with bearings (continued) | | | |
| 1st oversize red | mm (in) | 2.625 - 0.010 - 0.020 (0.1033 - 0.0004) | |
| blue | mm (in) | 2.635 - 0.010 - 0.020 (0.1037 - 0.0004) | |
| 2nd oversize red | mm (in) | 2.750 - 0.010 - 0.020 (0.1083 - 0.0004) | |
| blue | mm | 2.760 - 0.010 - 0.020 (0.1087 - 0.0004) | |
| Bearing play, radial | red | 0.030 ... 0.070 (0.0012 ... 0.0028) | |
| blue | mm (in) | 0.030 ... 0.068 (0.0012 ... 0.0027) | |
| Regrind stages - crankshaft guide bearing width | | | |
| Standard | mm (in) | 25.00 + 0.053 + 0.020 (0.9843 - 0.0021) | |
| 1st oversize | mm (in) | 25.20 + 0.053 + 0.020 (0.9221 - 0.0021) | |
| 2nd oversize | mm (in) | 25.40 + 0.053 + 0.020 (1.0000 - 0.0021) | |

*) Version for Sweden

Specifications

Engine

| Model | 320/6 320/6 A | 323 i 323 i A *) |
|---|------------------|--|
| 1121 . . . Crankshaft with bearings (continued) | | |
| Regrind stages – big end bearing journal diameter | | |
| Standard | mm (in) | 45.00 – 0.009 (1.7717 – 0.0004) 44.75 – 0.025 (1.7618 – 0.0010) |
| 1st undersize | mm (in) | 44.50 – 0.009 (1.7520 – 0.0004) |
| 2nd undersize | mm (in) | 44.50 – 0.025 (1.7520 – 0.0010) |
| Max. permissible crankshaft imbalance in each measuring plane (dynamic, without flywheel) | gcm | 25 |
| Crankshaft endplay | mm (in) | 0.080 . . . 0.163 (0.0031 – 0.0064) |
| Max. permissible runout at center main bearing journal (with crankshaft supported at outermost bearing journal) | | 0.15 (0.0059) |
| Crank pin throw | mm (in) | 66 ± 0.1 (2.5984 – 0.0039) |
| Max. permissible bearing journal surface roughness | μ | 76.8 ± 0.1 (3.0236 ± 0.0039) |
| *) Version for Sweden | | 1,5 |

Specifications

| Engine | | |
|---|------------------------|-------------------------------|
| Model | a) 320/6 b) 320/6 A | a) 323 i b) 323 i A *) |
| 1121 ... Toothed belt sprocket on crankshaft | | |
| Identification No. (on end face) | 1264531.3 | |
| Number of teeth | 21 | |
| 1122 ... Flywheel | | |
| Max. dynamic imbalance | gcm | a) 15 |
| Max. static imbalance | gcm | - |
| Max. lateral runout, measured at: 90 mm (3.54 in) dia. | mm (in) | a) 0.02 (0.0008) |
| 92 mm (3.62 in) dia. | mm (in) | b) 0.02 (0.0008) |
| 223 mm (8.78 in) dia. | mm (in) | a) 0.1 (0.0039) |
| Max. machining limit at contact face | mm (in) | a) 0.4 + 0.1 (0.016 + 0.0039) |

*) Version for Sweden

Specifications

Engine

| Model | 320/6 320/6 A | 323 i 323 i A *) |
|--|------------------|--|
| 11 23 . . . Vibration damper | | |
| V-belt pulley dia. | mm (in) | 146 (5,75) |
| Max. imbalance at 1000 min ⁻¹ | gcm | 8 |
| Max. radial runout at 200 mm (7.87 in) dia. | mm (in) | 0.2 (0.0008) |
| at 235 mm (9.25 in) dia. | mm (in) | - |
| Max. axial runout at app. 200 mm (7.87 in) dia. | mm (in) | 0.2 (0.008) |
| at app. 235 mm (9.25 in) dia. | mm (in) | - |
| 11 24 . . . Connecting rod and bearings | | |
| Connecting rod | | |
| Length from center of big end to center of small end | mm (in) | 130 ± 0.1 (5.118 ± 0.004) |
| Connecting rod bores – small end dia. | mm (in) | 24 + 0.021 0 (0.9449 + 0.0008) |
| big end dia. | mm (in) | 48 + 0.01 0 (1.8897 + 0.0004) |
| Small end bearing bushing – extl. dia | mm (in) | 24.060 . . . 24.100 (0.9472 . . . 0.9488) |
| intl. dia. | mm (in) | 22 + 0.010 0.005 (0.8661 + 0.0004 + 0.0002) |

*) Version for Sweden

Specifications

| Engine | | 320/6 320/6 A | 323 i 323 i A*) |
|--|---------|---|--------------------|
| Model | | | |
| 11 24 . . . Connecting rod with bearings (continued) | | | |
| Regrind stages | | | |
| Bearing shell thickness – Mfr. Glyco – Standard | mm (in) | 1.481 . . . 1.493 (0.0583 . . . 0.0588) | |
| Stage 1 oversize | mm (in) | 1.606 . . . 1.618 (0.0632 . . . 0.0637) | |
| Stage 2 oversize | mm (in) | | |
| Bearing play, radial | mm (in) | 0.029 . . . 0.079 (0.0011 . . . 0.0031) | |
| Regrind stages | | | |
| Bearing shell thickness – Mfr. KS – Standard | mm (in) | 1.484 . . . 1.494 (0.0584 . . . 0.0588) | |
| Stage 1 oversize | mm (in) | 1.609 . . . 1.619 (0.0633 . . . 0.0637) | |
| Stage 2 oversize | mm (in) | | |
| Bearing play, radial | mm (in) | 0.021 . . . 0.067 (0.0008 . . . 0.0026) | |
| Max. deviation from parallel of connecting rod bearing bores with bearing shells, at 150 mm (5.9 in) spacing mm (in) | | | ≤ 0.04 (0.0016) |
| Max. permissible twist to one side | deg | | 0° 30' |

*) Version for Sweden

Specifications

Engine

| Model | 320/6 320/6 A | 323 i 323 iA*) |
|---|-----------------------------------|-------------------|
| 1124 . . . Connecting rod with bearings (continued) | | |
| Max. weight variation among the 6 connecting rods of an engine (without bearing shells) | | ± 4 (0.141) |
| – at big end | | ± 2 (0.071) |
| – at small end | | ± 2 (0.071) |
| 1125 . . . Piston ¹⁾ | | |
| Weight group (punched or stamped on) | | + or – |
| Identification on piston (engine type/compression) ²⁾ | 2,0/9,2 | 2,3/9,5 |
| Piston diameter – standard | 79.98 ± 0.009 (3.14881 ± 0.00035) | |
| Intermediate oversize | 80.06 ± 0.009 (3.15196 ± 0.00035) | |
| 1st rebore oversize (+0.25 mm/0.0010 in) | 80.23 ± 0.009 (3.15866 ± 0.00035) | |
| 2nd rebore oversize (+0.50 mm/0.0020 in) | 80.48 ± 0.009 (3.16859 ± 0.00035) | |
| Piston installed clearance | 0.035 ± 0.010 (0.00137 ± 0.00039) | |

¹⁾ Version for Sweden

¹⁾ Always renew piston and piston (gudgeon) pin together, and note compression and piston pattern even if piston diameters are identical. Piston and pins are matched in pairs

²⁾ In addition, piston barrel diameter is shown, e.g. 79.98 (mm), and an arrow indicates direction of installation

Specifications

| Engine | Model | 320/6 320/6 A | 323 i 323 i A*) |
|--|---------|--|--------------------|
| 1125 . . . Piston (continued) | | | |
| Permissible difference in weight between the complete pistons of an engine ¹⁾ | g (oz) | 10 (0.35) | |
| Piston pin bore | mm (in) | $22 \begin{smallmatrix} + 0.004 \\ 0 \end{smallmatrix}$ (0.86614 $\begin{smallmatrix} + 0.00016 \\ 0 \end{smallmatrix}$) | |
| Piston pin bore offset | mm (in) | 0.7 (0.276) | |
| 1125 . . . Piston rings | | | |
| 1st groove (rectangular-section ring) Height | mm (in) | $1.50 \begin{smallmatrix} - 0.010 \\ - 0.022 \end{smallmatrix}$ (0.0591 $\begin{smallmatrix} - 0.0004 \\ - 0.0009 \end{smallmatrix}$) | |
| End gap | mm (in) | 0.3 . . . 0.5 (0.012 . . . 0.020) | |
| Vertical clearance in groove Mahle pistons | mm (in) | 0.060 . . . 0.092 (0.0024 . . . 0.0036) | |
| KS pistons | mm (in) | 0.050 . . . 0.082 (0.0020 . . . 0.0032) | |
| 2nd groove (micro-chamfer ring) ²⁾ Height | mm (in) | $2.00 \begin{smallmatrix} - 0.010 \\ - 0.022 \end{smallmatrix}$ (0.0787 $\begin{smallmatrix} - 0.0004 \\ - 0.0009 \end{smallmatrix}$) | |
| End gap | mm (in) | 0.3 . . . 0.5 (0.012 . . . 0.020) | |
| Vertical clearance in groove Mahle pistons | mm (in) | 0.030 . . . 0.062 (0.0012 . . . 0.0024) | |
| KS pistons | mm (in) | 0.040 . . . 0.072 (0.0016 . . . 0.0028) | |

*) Version for Sweden

1) Install only pistons from the same weight group (+ or -)

2) Not to DIN standard - special BMW pattern

Specifications

| Engine | | 320/6 320/6 A | 323 i 323 i A *) |
|---|---------|---|---|
| 11 25 . . . Piston rings (continued) | | | |
| 3rd groove (slotted oil scraper ring with tubular spring) ¹⁾ | mm (in) | | |
| Height | | 3.50 ⁻ 0.010 ⁻ | 3.50 ⁻ 0.010 ⁻ - 0.0004 ⁻ |
| | | | (0.1378 ⁻ 0.0009 ⁻) |
| End gap | mm (in) | 0.25 . . . 0.50 (0.0089 . . . 0.0197) | |
| Vertical clearance in groove | | | |
| Mahle pistons | mm (in) | 0.020 . . . 0.052 (0.0008 . . . 0.0020) | |
| KS pistons | mm (in) | 0.030 . . . 0.062 (0.0012 . . . 0.0024) | |
| 11 25 . . . Piston pin ²⁾ | | | |
| External diameter | mm (in) | 22 ⁻ 0 ⁻ | 22 ⁻ 0 ⁻ (0.86614 ⁻ 0.00016 ⁻) |
| Piston pin clearance in piston ²⁾ | | | |
| Mahle pistons | mm (in) | 0.001 . . . 0.005 (0.00004 . . . 0.00020) | |
| KS pistons | mm (in) | 0.002 . . . 0.006 (0.00008 . . . 0.00024) | |

*) Version for Sweden

1) Not to DIN standard – special BMW pattern

2) Always renew piston and piston pin together (piston pin and piston are a matched pair)

Specifications

| Engine | | 320/6 320/6 A | 323 i 323 i A *) |
|----------------------------|---------|--|---------------------|
| Model | | | |
| 1131 ... Camshaft | | | |
| Drive | | 260/110 | |
| Camshaft angles | deg. | | |
| Camshaft bearing dia. | mm (in) | 38.0 - 0.050 (1.4961 - 0.0020) 43.5 - 0.050 (1.7126 - 0.0020) 44.0 - 0.050 (1.7323 - 0.0020) 44.5 - 0.050 (1.7520 - 0.0020) 45.0 - 0.050 (1.7717 - 0.0020) 45.5 - 0.050 (1.7913 - 0.0020) 46.0 - 0.050 (1.8110 - 0.0020) | |
| Bore dia. in cylinder head | mm (in) | 38.0 + 0.034 (1.4961 + 0.0013) 43.5 + 0.034 (1.7126 + 0.0013) 44.0 + 0.034 (1.7323 + 0.0013) 44.5 + 0.034 (1.7520 + 0.0013) | |

*) Version for Sweden

Specifications

| Engine | | 320/6 320/6 A | 323 i 323 i A*) |
|--|----------------|---|---|
| 1131 ... Camshaft (continued) | | | |
| Bore dia. in cylinder head (continued) | mm (in) | 45.0 + 0.034 (1.7717 + 0.0013) + 0.009 (1.7717 + 0.0004) | 45.5 + 0.034 (1.7913 + 0.0013) + 0.009 (1.7913 + 0.0004) |
| | | 46.0 + 0.034 (1.8110 + 0.0013) + 0.009 (1.8110 + 0.0004) | |
| Running clearance | radial mm (in) | 0.059 ... 0.1 (0.0023 ... 0.0039) | |
| | axial mm (in) | 0.2 (0.0079) | |
| Cam base circle dia. | mm (in) | 27.9898 (1.102) | |
| Cam lift | mm (in) | 6.5809 ± 0.080 (0.2591 ± 0.0031) | |
| 1131 ... Toothed belt | | | |
| Number of teeth | | 111 | |
| Belt width | mm (in) | 25.4 (1.0) | |
| 1131 ... Toothed belt sprocket on camshaft | | | |
| Identification number (on endface) | | 1 264 532 | |
| Number of teeth | | 42 | |

*) Version for Sweden

Specifications

| Engine | | 320/6 320/6 A | 323 i 323 i A *) |
|--|--|----------------------|----------------------------|
| Model | | | |
| 1131 . . . Toothed belt sprocket on intermediate shaft | | | |
| Identification number on endface | | 1 265 458 | |
| Number of teeth | | 28 | |
| 1131 . . . Tensioner pulley with tensioning device (for toothed belt) | | | |
| Make | | FAG/INA/SKF | |
| Axial runout (on running surface, at 52 mm (2.05 in) dia. on side guide) mm (in) | | 0.3 (0.0118) | |
| Radial runout mm (in) | | 0.2 (0.0079) | |
| 1133 . . . Rockers with pivots | | | |
| Rocker bore without bushing mm (in) | | 20 + 0.021 + 0 | (0.7874 + 0.0008) |
| Rocker bushing bore dia. in rocker mm (in) | | 17.5 + 0.018 + 0 | (0.6890 + 0.0007) |
| Rocker shaft dia. mm (in) | | 17.5 - 0.016 - 0.034 | (0.6890 - 0.0006 + 0.0013) |
| Rocker running clearance mm (in) | | 0.016 . . . 0.052 | (0.0006 . . . 0.0020) |

*) Version for Sweden

Engine Specifications

| | | |
|---|--------------------------------------|---------------------|
| Model | 320/6 320/6 A | 323 i 323 i A *) |
| 1134 . . . Valves | | |
| Valve actuation | by light alloy rockers ¹⁾ | |
| Valve clearances Inlet and exhaust (at max. coolant temperature 35°C/95°F) mm (in) | 0.25 (0.0098) ²⁾ | |
| Valve clearance adjustment | by eccentrics in rockers | |
| Order of adjustment Cylinder at top dead center on compression stroke | 1 5 3 6 2 4 | |
| Valve overlap in cylinder | 6 2 4 1 5 3 | |

*) Version for Sweden

1) with chill-cast pads and single overhead camshaft

2) at operating temperature (thermostat at limit of travel): 0.3 mm (0.0118 in)

Specifications

| Engine | 320/6 320/6 A | 323 i 323 i A *) |
|--|------------------|---------------------|
| Model | | |
| 1134 . . . Valves (continued) | | |
| Valve timing (with 0.5 mm (0.002 in) clearance between cam base circle and rocker contact face) | | |
| Inlet opens before TDC | °CS | 11° |
| Inlet closes after BDC | °CS | 47° |
| Exhaust opens before BDC | °CS | 51° |
| Exhaust closes after TDC | °CS | 7° |
| Inlet phase | °CS | 238° |
| Exhaust phase | °CS | 238° |
| Valve timing (at 0.30 mm (0.012 in) clearance between cam base circle and rocker contact face) ¹⁾ | | |
| Inlet opens before TDC | °CS | 22° |
| Inlet closes after BDC | °CS | 58° |
| Exhaust opens before BDC | °CS | 62° |
| Exhaust closes after TDC | °CS | 18° |
| Inlet phase | °CS | 260° |
| Exhaust phase | °CS | 260° |

*) Version for Sweden
 Inlet = 1.179
 1) Overlap: Exhaust=0.813

Engine Specifications

| Engine | 320/6 A 320/6 A | 323 i 323 i A*) |
|--|--------------------|--|
| 11 34 . . . Valves (continued) | | |
| Valves | | |
| Overall length | Inlet mm (in) | 102.5 ± 0.2 (4.035 ± 0.008) |
| | Exhaust mm (in) | 102.5 ± 0.2 (4.035 ± 0.008) |
| Head diameter | Inlet mm (in) | 40 ⁰ _{-0.016} (1.5748 ^{0.0006} _{-0.0006}) |
| | Exhaust mm (in) | 34 ⁰ _{-0.016} (1.3386 ⁰ _{-0.0006}) |
| | | 6.975 ⁰ _{-0.015} (0.2746 ⁰ _{-0.0006}) |
| Stem diameter | Inlet mm (in) | 6.960 ⁰ _{-0.015} (0.2740 ⁰ _{-0.0006}) |
| | Exhaust mm (in) | |
| Edge thickness of valve head in new condition | Inlet mm (in) | 1.5 ± 0.15 (0.0591 ± 0.0059) |
| | Exhaust mm (in) | 1.5 ± 0.15 (0.0591 ± 0.0059) |
| Min. edge thickness of valve head after machining | Inlet mm (in) | 1.2 (0.047) |
| | Exhaust mm (in) | 1.2 (0.047) |

*) Version for Sweden

Specifications

| Engine | 320/6 A 320/6 A | | 323 i 323 i A*) |
|---|--------------------|---------|---|
| 11 34 . . . Valves (continued) | | | |
| Model | | | |
| Valve seat angle | Inlet | deg. | 44° 30' – 20' |
| | Exhaust | deg. | 44° 30' – 20' |
| Permissible runout, valve seat/stem | Inlet | mm (in) | 0.02 (0.0008) |
| | Exhaust | mm (in) | 0.02 (0.0008) |
| Valve operating clearance (radial) | Inlet | mm (in) | 0.025 . . . 0.055 (0.0010 . . . 0.0022) |
| | Exhaust | mm (in) | 0.040 . . . 0.070 (0.0016 . . . 0.0028) |
| Max. clearance at wear limit | mm (in) | | 0.1 (0.0039) |
| 11 34 . . . Valve springs | | | |
| Identification (at bottom in installed position) – color (according to make) | | | green white yellow |
| Wire thickness | mm (in) | | 4.25 (0.167) |
| Extl. dia. of spring | mm (in) | | 31.90 ± 0.2 (1.256 ± 0.008) |
| Relaxed length of spring, according to make | mm (in) | | 43.5 (1.713) |
| | mm (in) | | 46.0 (1.811) |

*) Version for Sweden

Specifications

| Engine | 320/6 320/6 A | 323 i 323 i A*) |
|--|--------------------------|--|
| Model | | |
| 1134 . . . Valve springs (continued) | | |
| Spring force/test length (valid for valve springs color coded green, yellow or white) | | |
| | N/mm lb.f/in kp/mm | 284.5 ± 11.8/37.6 63.9 ± 2.7/1.481 29 ± 1.2/37.6 |
| | N/mm lb.f/in kp/mm | 686.7 ± 27.5/28.5 154.3 ± 6.2/1.122 70 ± 2.8/28.5 |
| 1135 . . . Intermediate timing shaft | | |
| Bearing seat dia. | mm (in) | 38 - 0.009 (1.4961 - 0.0004) 36.5 - 0.009 (1.4370 - 0.0004) - 0.025 (1.4961 - 0.0010) - 0.025 (1.4370 - 0.0010) |
| Extl. dia. for gearwheel | mm (in) | 18 + 0.048 (0.7087 + 0.0019) + 0.035 (0.7087 + 0.0014) |
| Gearwheel (for intermediate shaft) | | |
| Number of teeth | | 12 |
| Bore diameter | mm (in) | 18 - 0.005 (0.7087 - 0.0002) - 0.023 (0.7087 - 0.0009) |

*) Version for Sweden

Specifications

| Engine | Specifications | |
|--|--|---------------------|
| Model | 320/6 320/6 A | 323 i 323 i A *) |
| 1140 . . . Oil supply (engine lubrication), general | | |
| Lubrication system | Pressure oil circuit ¹⁾ | |
| Fullflow oil filter and element | see Item 1142 . . . | |
| Oil pressure warning lamp comes on below (gauge pressure) bar (lb/in ²) | 0.2 . . . 0.5 (2.84 . . . 7.11) | |
| Oil content – without filter change l (Imp. pints, US quarts) | 4.5 (7.9, 4.8) | |
| – with filter change l (Imp. pints, US quarts) | 4.75 (8.4, 5.0) | |
| Oil grade | Brand-name HD oil for spark-ignition engines | |
| Viscosity at outside temperatures: mostly above + 30 °C (+ 86 ° F) Multigrade oils | SAE 20 W 50 | |
| Single grade oils | SAE 40 | |
| from – 10 °C (+14° F) to + 30 °C (+86° F) Multigrade oils | SAE 20 W 50 | |
| Single grade oils | SAE 30 | |
| from + 10 °C (+50° F) to – 30 °C (–22° F) Multigrade oils | SAE 10 W 30 SAE 10 W 40 SAE 10 W 50 | |
| Single grade oils | SAE 20 | |

*) Version for Sweden

1) Pressure regulating valve in filtered oil circuit

Specifications

Engine

| Model | 320/6 A 320/6 A | 323 i 323 i A*) |
|--|--|--------------------|
| 11 40 . . . Oil supply – (continued) | | |
| all the year round above –10 °C (+14 ° F) Multigrade oils | | |
| Single grade oils | SAE 20 W 50 | – |
| all the year round above –20 °C (–4 ° F) Multigrade oils | | |
| Single grade oils | SAE 15 W 50 | – |
| all the year round below –10 °C (+14 ° F) Multigrade oils | | |
| Single grade oils | SAE 5 W 20 SAE 5 W 30 | – |
| Max. oil consumption ¹⁾ | l/100 km (mile/imp. pint, mile/US quart) | 0.15 (235, 392) |

*) Version for Sweden

1) see also page 11-0/38

Specifications

| Engine | 320/6 320/6 A | 323 i 323 i A *) |
|--|---------------------------|--|
| Model | | |
| 1141 . . . Oil pump | | |
| Oil pump pattern | | Gear type |
| Oil pressure at idle speed (gauge) | bar (lb/in ²) | 0.5 . . . 1.0 (7.1 . . . 14.2) |
| Oil pressure at maximum speed (gauge) | bar (lb/in ²) | 5.0 . . . 6.0 (71 . . . 85) |
| Opening pressure of relief valve in oil pump cover (gauge) | bar (lb/in ²) | 8 . . . 9 (114 . . . 128) |
| Length of helical spring in oil pump cover | mm (in) | 44 ± 0.2 (1.732 ± 0.008) |
| Drive shaft/camshaft diameter | mm (in) | 15 ⁰ - 0.011 (0.5906 ⁻⁰ - 0.0004) |
| Bore for drive shaft/ camshaft in housing | mm (in) | 15 ⁺ 0.043 (0.5906 ⁺ + 0.0017) + 0.016 (0.0006 ⁺ + 0.0006) |
| Radial clearance at oil pump gearwheels (driveshaft and auxiliary shaft) | mm (in) | 0.016 . . . 0.054 (0.0006 . . . 0.0021) |

*) Version for Sweden

Specifications

| Engine | 320/6 320/6 A | 323 i 323 i A *) |
|---|--|---|
| 11 41 . . . Oil pump – (continued) | | |
| Model | | |
| Depth of housing for oil pump gearwheels | mm (in) | 19.2 ± 0.06 (0.7559 \pm 0.0024) ± 0.03 \pm 0.0012) |
| Height of oil pump gearwheels | mm (in) | 19.2 ± 0.020 (0.7559 \pm 0.0008) ± 0.041 \pm 0.0016) |
| Max. endplay of oil pump gears | mm (in) | 0.11 (0.0043) |
| Permissible oil pump gearwheel backlash | mm (in) | 0.2436 (0.0096) |
| Drive system | By helical gear from intermediate timing shaft, via extension of distributor shaft | |
| 11 42 . . . Oil filter and lines | | |
| Fullflow oil filter | | |
| Pressure relief valve opening pressure (gauge) | bar (lb/in ²) | 2.2 ± 0.3 (31.3 \pm 4.3) |
| Length of coil spring for pressure relief valve – relaxed | mm (in) | 68 (2.677) |
| – as installed | mm (in) | 66.5 (2.618) |
| Length of pressure relief valve plunger | mm (in) | 35 (1.378) |
| Oil filter element (replaceable fullflow oil filter) | One-way (throwaway) element | |

*) Version for Sweden

Specifications

Engine

| | | |
|---|-------------------------------|-----------------------------|
| Model | 320/6 320/6 A | 323 i 323 i A *) |
| 11 51 . . . Water pump | | |
| Gap between cover ring in housing and impeller wheel | mm (in) | 0.6 ± 0.2 (0.024 ± 0.008) |
| 11 53 . . . Thermostat (for coolant) | | |
| Opening movement starts | °C (°F) | 80 ± 1.5 (176 ± app. 2) |
| Working stroke (at zero pressure) | mm (in) | 8 (0.32) |
| 11 74 . . . Heat-sensitive (thermo-) valve (for exhaust emission reduction system) | | |
| Make | Texas Instruments or Pierburg | - |
| Type | Texas Instruments Pierburg | 23 VT 51 AB-12 PE 20 286 |
| Color of top section | Texas Instruments Pierburg | blue yellow |
| Switching point | | |
| "Open" | Texas Instruments Pierburg | 20 (68) 20 (68) |
| "Close" | Texas Instruments Pierburg | 13 (55) 13 (55) |

*) Version for Sweden

Specifications

| Engine | 320/6 320/6 A | 323 i 323 i A *) |
|---|--------------------|---|
| Model | | |
| Tightening torques | | |
| 11 11 ... Engine block (cylinder block and crankcase) | | |
| Main bearing caps | Nm kpm lb.ft | 58.9 ... 65.7 6.0 ... 6.7 43.4 ... 48.4 |
| Front engine block end cover | M 6 | 8.8 ... 10.8 0.9 ... 1.1 6.5 ... 8.0 |
| | M 8 | 21.6 ... 23.5 2.2 ... 2.4 15.9 ... 17.3 |
| Rear engine block end cover | M 6 | 8.8 ... 10.8 0.9 ... 1.1 6.5 ... 8.0 |
| | M 8 | 21.6 ... 23.5 2.2 ... 2.4 15.9 ... 23.5 |
| Tensioning pulley at engine block | M 8 | 21.6 ... 23.5 2.2 ... 2.4 15.9 ... 23.5 |

*) Version for Sweden

Specifications

| Engine | Model | 320/6 A 320/6 A | 323 i 323 i A*) |
|--|--------------------|---|---|
| Tightening torques (continued) | | | |
| 1112 . . . Cylinder head | | | |
| Cylinder head bolts (in crosswise pattern, starting from center and working outwards in two tightening stages) | Stage 1 | Nm kpm lb.ft | 30 . . . 35 ¹⁾ 3.05 . . . 3.56 ¹⁾ 22 . . . 26 ¹⁾ |
| | Stage 2 | Nm kpm lb.ft | 60 . . . 65 ¹⁾ 6.11 . . . 6.62 ¹⁾ 44 . . . 48 ¹⁾ |
| Cover on cylinder head M 6 | Nm kpm lb.ft | 8.8 . . . 9.8 0.9 . . . 1.0 6.5 . . . 7.2 | |
| Guide cover on cylinder head M 6 | Nm kpm lb.ft | 8.8 . . . 9.8 0.9 . . . 1.0 6.5 . . . 7.2 | |
| Rocker cover to cylinder head | Nm kpm lb.ft | 8.8 . . . 9.8 0.9 . . . 1.0 6.5 . . . 7.2 | |
| Guard cover on cylinder head and front end cover | M 6 | Nm kpm lb.ft | 8.8 . . . 9.8 0.9 . . . 1.0 6.5 . . . 7.2 |
| | M 8 | Nm kpm lb.ft | 21.6 . . . 23.5 2.2 . . . 2.4 15.9 . . . 17.3 |

*) Version for Sweden

1) with engine cold (max. 35° C (95° F) coolant temperature)

Specifications

| Engine | 320/6 320/6 A | 323 i 323 i A *) |
|---|--------------------|---|
| Tightening torques (continued) | | |
| 11 13 ... Sump | | |
| Oil drain plug | Nm kpm lb.ft | 58.9 ... 63.8 6.0 ... 6.5 43 ... 47 |
| Sump to engine block (crankcase) | Nm kpm lb.ft | 8.8 ... 10.8 0.9 ... 1.1 6.5 ... 8.0 |
| 11 22 ... Flywheel | | |
| Flywheel to crankshaft ¹⁾ | Nm kpm lb.ft | 98.1 ... 112.8 10.0 ... 11.5 72 ... 83 |
| 11 23 ... Vibration damper | | |
| V-belt pulley with vibration damper to hub M 8 | Nm kpm lb.ft | 21.6 ... 23.5 2.2 ... 2.4 15.9 ... 17.3 |
| Vibration damper with hub to crankshaft (with M 18 x 1.5 mm hex bolt) | Nm kpm lb.ft | 392.3 ... 432.1 40.0 ... 44.0 298 ... 319 |

*) Version for Sweden

1) install with Loctite No. 270

Specifications

Engine

| | | |
|--|--------------------|---|
| Model | 320/6 320/6 A | 323 i 323 i A *) |
| Tightening torques (continued) | | |
| 1124 ... Connecting rod with bearings | | |
| Big end bolts | Nm kpm lb.ft | 20 ¹⁾ 2.0 14.7 |
| 1131 ... Camshaft | | |
| Toothed belt sprocket to camshaft M 10 | Nm kpm lb.ft | 54.9 ... 64.7 5.6 ... 6.6 40.5 ... 47.7 |
| Adapter to disc M 6 | Nm kpm lb.ft | 8.8 ... 9.8 0.9 ... 1.0 6.5 ... 7.2 |
| 1133 ... Rockers with bearings | | |
| Clamp bolt on rocker | Nm kpm lb.ft | 8.8 ... 10.8 0.9 ... 1.1 6.5 ... 8.0 |
| 1135 ... Intermediate timing shaft | | |
| Toothed belt sprocket to intermediate shaft M 10 | Nm kpm lb.ft | 39.3 ... 43.2 4.0 ... 4.4 29 ... 32 |

*) Version for Sweden

1) Tighten bolts by hand to 20 Nm (14.7 lb.ft) plus = 70° angle of rotation or turn the bolts through a further 70° with special tool 11 2 110 (when repairing always replace the bolts, use bolts only once).

Specifications

Engine

| Model | 320/6 A 320/6 A | 323 i 323 i A*) |
|--|--------------------|---|
| Tightening torques (continued) | | |
| 1141 . . . Oil pump | | |
| Screw plug for pressure relief valve, M 18 × 1.5 mm | Nm kpm lb.ft | 24.5 . . . 29.4 2.5 . . . 3.0 18 . . . 22 |
| Oil pump cover, oil strainer and screen plate at oil pump housing M 6 | Nm kpm lb.ft | 8.8 . . . 9.8 0.9 . . . 1.0 6.5 . . . 7.2 |
| Oil pump to engine block M 8 | Nm kpm lb.ft | 21.6 . . . 23.5 2.2 . . . 2.4 15.9 . . . 17.3 |
| 1142 . . . Oil filter and lines | | |
| Pressure relief valve or valve housing, M 20 × 1.5 mm | Nm kpm lb.ft | 37.2 . . . 41.2 3.8 . . . 4.2 27 . . . 30 |
| Fullflow oil filter (replaceable throwaway element) – with engine cold – | Nm kpm lb.ft | 23.6 . . . 25.5 2.4 . . . 2.6 17.4 . . . 18.8 |
| Collar screws for oil pipe, camshaft lubrication (M 8 × 1 mm) | Nm kpm lb.ft | 5.9 . . . 7.85 0.6 . . . 0.8 4.4 . . . 5.9 |

*) Version for Sweden

Specifications

| Engine | | | 320/6 320/6 A | 323 i 323 i A *) |
|---|--------------------|--|---|---------------------|
| Model | | | | |
| Tightening torques (continued) | | | | |
| 1151 . . . Water pump with drive | | | | |
| Water pump with engine block M 8 | Nm kpm lb.ft | | 21.6 . . . 23.5 2.2 . . . 2.4 15.9 . . . 17.3 | |
| Belt pulley to water pump M 6 | Nm kpm lb.ft | | 8.8 . . . 9.8 0.9 . . . 1.0 6.5 . . . 7.2 | |
| 1153 . . . Thermostat and connections | | | | |
| Cover to thermostat housing M 6 | Nm kpm lb.ft | | 8.8 . . . 9.8 0.9 . . . 1.0 6.5 . . . 7.2 | |
| 1153 . . . Coolant temperature sensor | | | | |
| Coolant temperature sensor | Nm kpm lb.ft | | 24.5 . . . 27.5 2.5 . . . 2.8 18.1 . . . 20.3 | |
| 1162 . . . Exhaust manifold | | | | |
| Hex nut for exhaust manifold at cylinder head | Nm kpm lb.ft | | 29.4 . . . 32.4 3.0 . . . 3.3 21.7 . . . 23.9 | |

*) Version for Sweden

Specifications

Engine

| Model | 320/6 320/6 A | 323 i 323 i A *) |
|---|---|---|
| Tightening torques (continued) | | |
| 1174 . . . Heat-sensitive (thermo-) valve for exhaust emission control | | |
| Heat-sensitive valve Mfr. Texas Instruments, max. Nm kpm lb.ft | 24.5 . . . 27.5 2.5 . . . 2.8 18.1 . . . 20.3 | — — — |
| Mfr. Pierburg | 24.5 . . . 27.5 2.5 . . . 2.8 18.1 . . . 20.3 | — — — |
| 1181 . . . Engine mountings | | |
| Left and right engine mountings (rubber bushings) at front axle beam (M 10) | | 49 . . . 54 5.0 . . . 5.5 36 . . . 40 |
| Left and right engine mountings (rubber bushings) to support bracket (M 10) | | 49 . . . 54 5.0 . . . 5.5 36 . . . 40 |
| Left support bracket on engine (M 8) | | 22 . . . 24 2.2 . . . 2.4 16 . . . 18 |
| Right support bracket on engine (M 8) | | 22 . . . 24 2.2 . . . 2.4 16 . . . 18 |

*) Version for Sweden

Specifications

| Engine | | |
|--------|------------------|---------------------|
| Model | 320/6 320/6 A | 323 i 323 i A *) |

Determining oil consumption

Oil consumption can be measured after the vehicle has covered about 7 500 km (5 000 miles). Until then, the oil consumption will not have stabilized at a constant figure.

The engine must be free from oil leaks.

Permissible oil consumption is not exceeding 0.15 l/100 km (235 miles/imp. pint, 392 miles/US quart).

The exact oil consumption must be determined by weighing.

Drain the engine oil while it is at normal operating temperature.

Draining time is 5 minutes. Weigh and fill with prescribed oil quantity¹⁾ – use new engine oil.

Drive vehicle for 1000 km/600 miles. Drain the engine oil while it is at normal operating temperature and weigh. Draining time is 5 minutes. Specific gravity of engine oil at ambient temperature is app. 0.9.

Example: Filled-in oil quantity – drained oil quantity

$$900 - \text{Sp. Gr. } 0.9 = 1000 \text{ cm}^3 = 1 \text{ litre per } 1000 \text{ km}$$

$$4500 \text{ g} - 3600 \text{ g} = 900 \text{ g}$$

Possible causes of excessive oil consumption:

1. Running in not yet complete.
2. Damaged sealing caps on valve stems.
3. Piston seizure.
4. Piston rings incorrectly installed, broken or worn.
5. Excessive running clearance between valve stem and valve guide.

*) Version for Sweden

Specifications

Engine

| | | |
|-------|------------------|--------------------|
| Model | 320/6 320/6 A | 323 i 323 i A*) |
|-------|------------------|--------------------|

Determining fuel consumption by DIN 70 030 standard test method

The vehicle's engine settings (ignition timing, fuel supply system etc.) must be to standard specification¹⁾.

The tire size must be as shown in the registration documents.

Tire pressures must be adjusted until as specified.

The brakes must be fully released.

The engine should have already covered at least 7 500 km (5 000 miles), and be at normal operating temperature.

During fuel consumption measurements, the vehicle should be laden to a point halfway between the permissible gross weight and the unladen weight.

Speed over the entire test course should be as uniform as possible, and three-quarters of the previously determined maximum speed, but not more than 110 km/h (68.5 mile/h).

The test route should be as smooth and flat as possible, and approx. 10 km (6.3 miles) in length. It should be covered in both directions. Rising and falling gradients of up to 1.5% are permitted.

The air temperature should be between + 10 and + 30°C (50 ... 86°F) and the wind speed not more than 3 m/s (590 ft/min).

The vehicle's tank should be filled with a standard commercially-available grade of fuel (as specified by the manufacturer).

Fuel consumption is to be determined with a commercial meter or by means of the following formula, with a 10 % additional allowance for unfavorable circumstances.

$$\frac{\text{Fuel consumed} \times 100}{\text{Distance covered in km}} = \text{Fuel consumption by standard test method}$$

*) Version for Sweden

1) See specifications



11 00 005 Diagnosis with BMW program tester/BMW digital tester

| Switch position | Item tested | Page |
|------------------------|--|---------|
| | Connecting program tester | 11-00/3 |
| U (B +) | Battery voltage without power consumers | 00/5 |
| U (15) | Voltage at ignition coil terminal 15 | 00/5 |
| | a) Ignition coil static current | |
| | b) When starting | |
| U (1) | Voltage drop at contact breakers and plugs | 00/6 |
| Rr | Capacitor-distributor | 00/7 |
| U (D +) | Alternator and regulator | 00/8 |
| Schl | Dwell angle | 00/10 |
| KV | Oscillograph display adjustments (basic trace) | 00/10 |
| | Cam displacement-distributor | 00/11 |
| | Contact breaker points | 00/12 |
| | Ignition coil polarity | 00/12 |
| | Capacitor-distributor | 00/12 |
| Digital tester | Ignition timing | 00/13 |
| Digital tester | Centrifugal ignition control | 00/14 |
| Digital tester | Vacuum ignition control | 00/14 |
| | Ignition voltage | 00/16 |
| | Ignition voltage/high tension insulation | 00/17 |
| | Comparative display of cylinders | 00/20 |
| Bal | Balancing cylinder display | 00/21 |
| Test values | | 00/23 |
| Additional test | | 00/25 |
| Additional test values | | 00/27 |

Connect BMW program tester to 220 volt power supply.
 Connect test leads and manual remote control on program tester.
 Plug adaptor cable No. 61 1 216 into diagnosis socket on car and connect with program test cable.

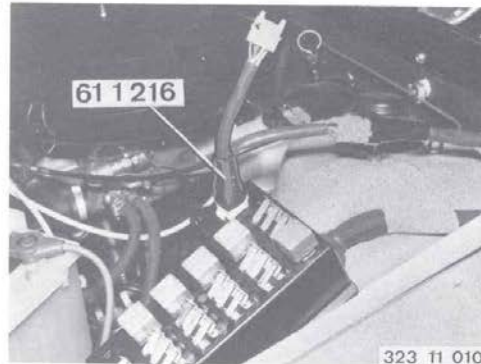

On 323i:
 Remove air tube.

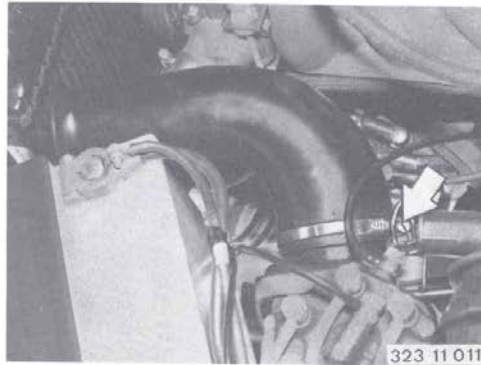

Connect detector clip 1 687 224 529 to cylinder 1 lead and detector clip 1 687 224 530 to ignition coil/distributor lead 4.

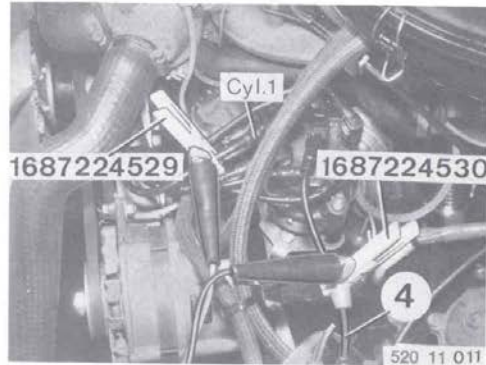

Set range switch to program.
 Tester is ready for use when yellow indicator lamp is on.
 If not, check 1 ampere fuse above main power supply cord.
 Set cylinder selector switch to 6.

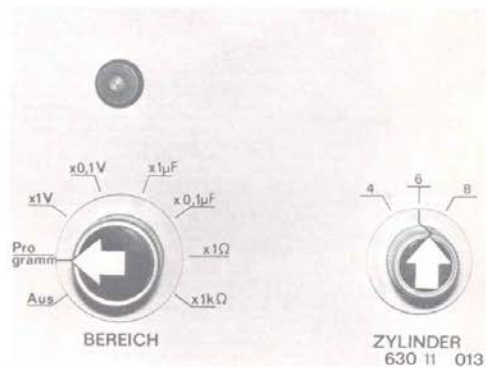

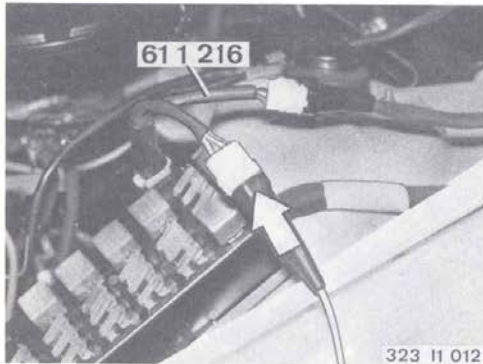

Connect BMW digital tester.
Connect test cable with adaptor cable No.
61 1 216.

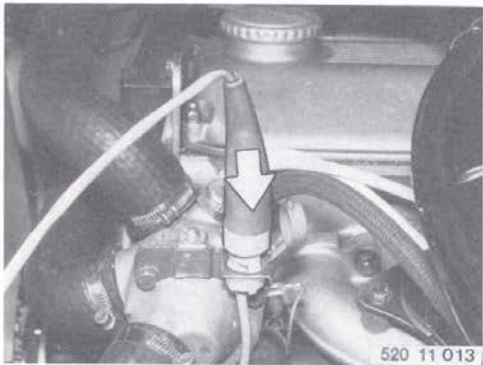

Connect cable for TDC transmitter.

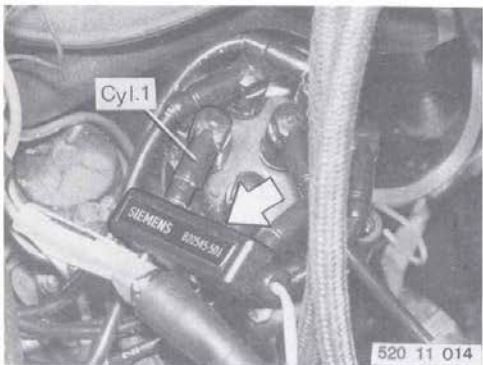

Connect trigger clip to cylinder 1 lead as close
as possible to the distributor.



**Switch position U (B +)
16 volt scale.
Check battery voltage¹⁾ with consumers off.
Engine stopped, ignition turned off.**



630 11 015



**Switch position U (15)
16 volt scale**

Version with breaker points:

Turn on ignition at ignition switch. Do not turn on ignition with manual remote control.

a) Measure ignition coil static current¹⁾ (terminal 15).

**b) Start engine at ignition switch.
Check voltage¹⁾ at ignition coil while operating starter motor.**

Version with contactless transistorized coil ignition:

**Important: Never work on the contactless transistorized coil ignition system unless the engine is stopped and the ignition switched off.
Danger of electric shock!**

**Switch on the ignition at the ignition key.
Measure voltage¹⁾ at coil terminal 1.**

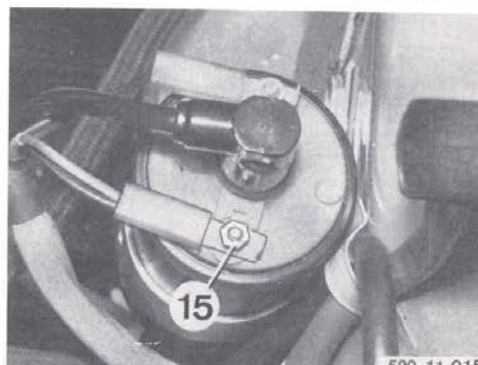

520 11 015

¹⁾ See test values

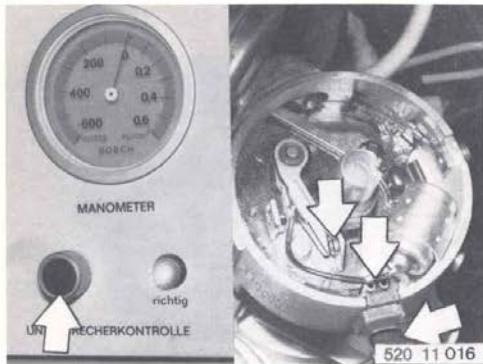

Switch position U (1)

1.6 volt scale

Ignition turned off. Press contact breaker control switch.

Green indicator lamp must be on. If not, operate starter motor until green lamp comes on (contact closes).

Read voltage drop¹⁾.

If maximum specifications are exceeded, check contact breaker points and plugs.

¹⁾ See test values.

Capacitor series resistance



Switch position Rr Rr scale

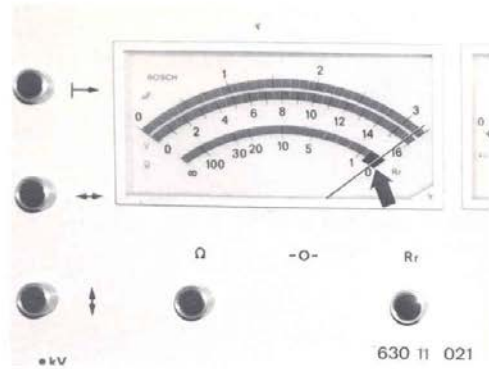

Ignition switched off.

Remove distributor cap.

Detach wire at contact breaker point and wire 1 at plug connector of distributor. Hold wire 1 against ground and adjust needle to lower edge (0) of Rr scale with rotary switch knob Rr. Connect wire 1 to plug connector of distributor.

The capacitor is in working order if the reading is within the wide range. Install distributor cap.

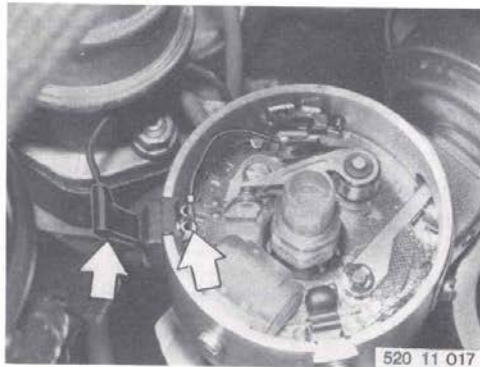

Important! Capacitor series resistance will retard the ignition timing. The defect must be found and corrected before adjusting the ignition timing.



Switch position U (D+)
2000 min⁻¹ scale

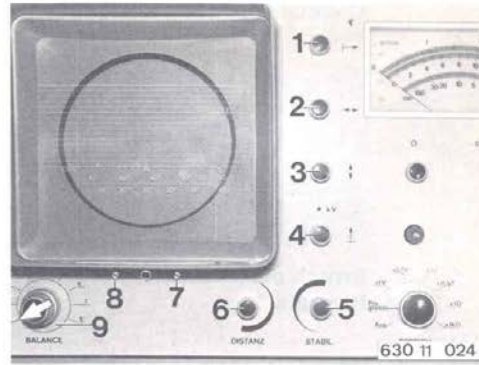

Set balance switch (9) to O.

Turn distance rotary switch knob (6) to left stop.

Adjust image width between 0 and 100% with rotary switch knobs \leftrightarrow (2) and \rightarrow (1).

Adjust image to zero line with knob \downarrow (3).

Start engine with remote control.

Switch on high beam headlights and other electrical consumers if necessary to prevent superimposition of the oscillograph images. Adjust stable rotary switch knob (5) with engine running at speed of 900 min⁻¹ until the upper harmonic waves remain constant.

Turn rotary switch knob \uparrow (4) until the upper harmonic wave is about 5 mm (0.2 in).

Important! Only adjust the image focus (8) and image brightness (7) when absolutely necessary.

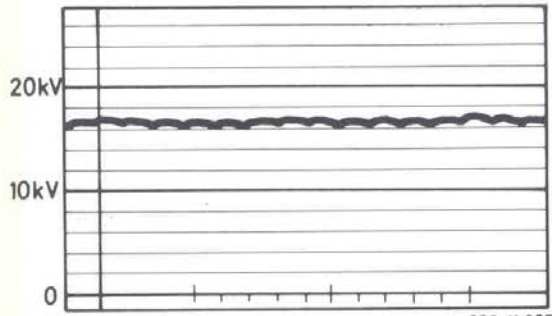

Alternator in proper working order.

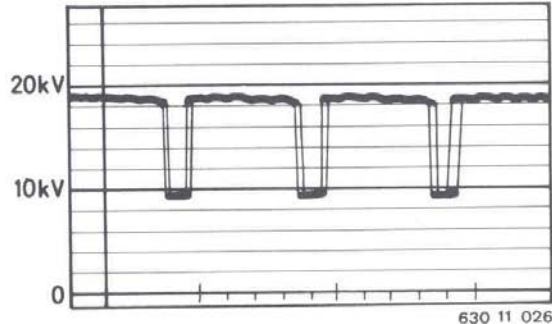

Break at one positive diode.



Break at one exciter diode.

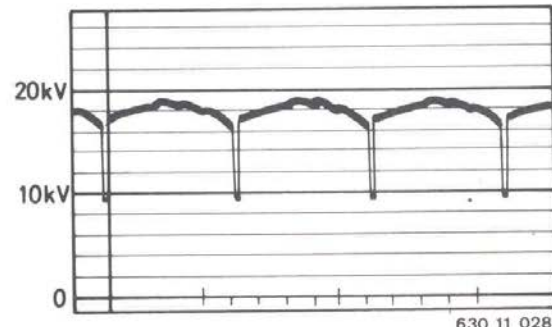

Break at one negative diode.

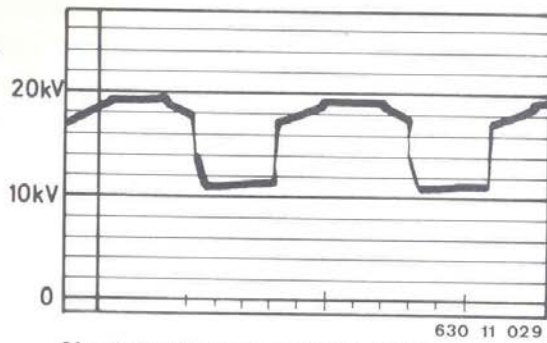

Short circuit at one exciter diode.

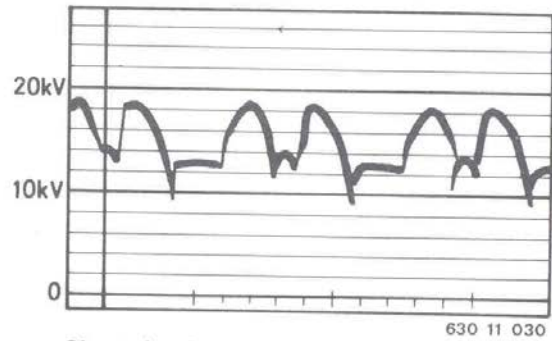

Short circuit at one positive diode.

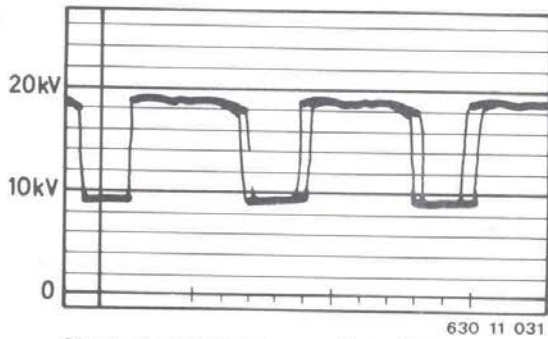

Short circuit at one negative diode.

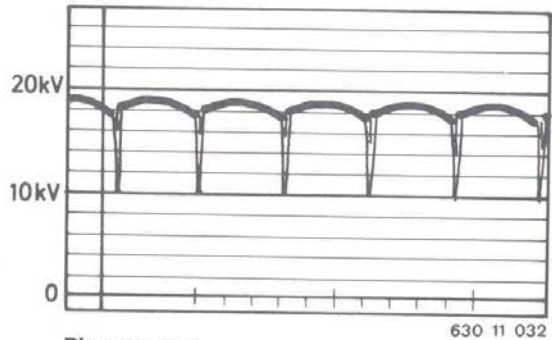

Phase error.

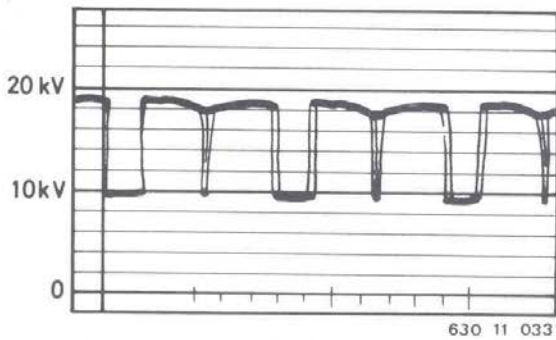

Phase error and short-circuited negative diode.

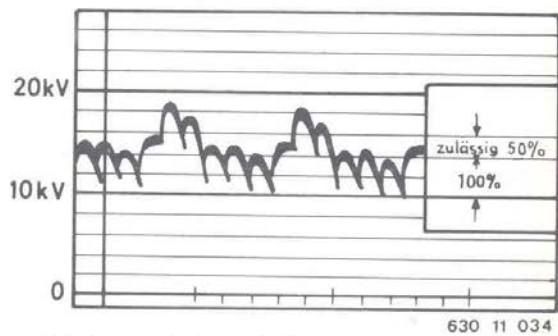

Diodes with altered characteristic.
Important! Deviations below 50% are still acceptable. If deviations are greater than this, the defective diode must be replaced.



Switch position: dwell angle
 Engine speed 2000 min⁻¹
 60° dwell angle scale

Version with contactless transistorized coil ignition:

Note: dwell angle is a fixed design feature and cannot be varied.

Check dwell angle
 at 1500 min⁻¹ = 42° ± 10°
 at 4500 mm⁻¹ = 52° ± 5°.

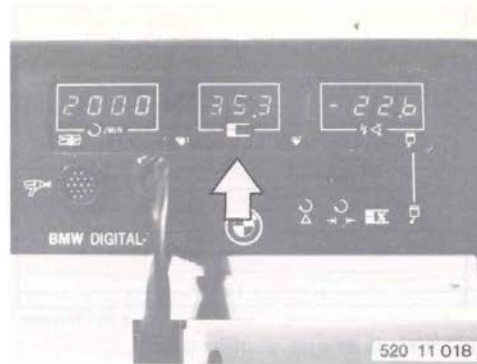

Read off dwell angle at digital tester.

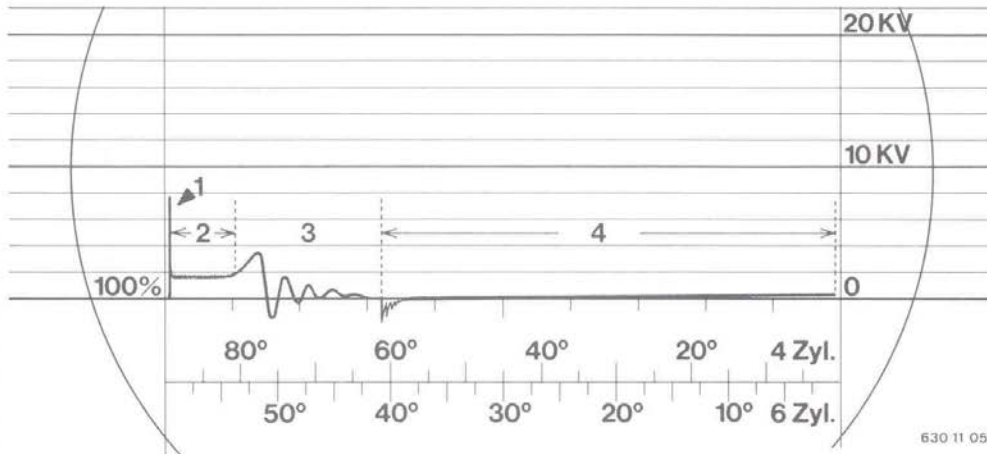

Basic image EXTERNAL

This oscillograph shows the ignition voltage pattern for one cylinder; if the ignition system is in good working order the ignition voltage peak (1) actually appears on the right screen edge-basic image internal. It is produced at the moment when the contact breaker points open.

Combustion voltage line (2) shows the further progress of the ignition spark, which continues to glow for a brief period.

Dying out phase (3) shows how the ignition spark is broken off and dies away.

Closing period (4) = dwell angle.

The contact breaker points are shut. This is the closed period.

All deviations from the basic image mean faults in ignition system.

Version with breaker points:

Adjusting dwell angle
Switch off engine.
Remove distributor cap, rotor and dust cap.
Run engine with starter.
Adjust dwell angle to 35... 41° by turning the point carrier.
Strive for the smallest value.
The value can be read off directly at the digital tester during the adjustment, at starter speed.

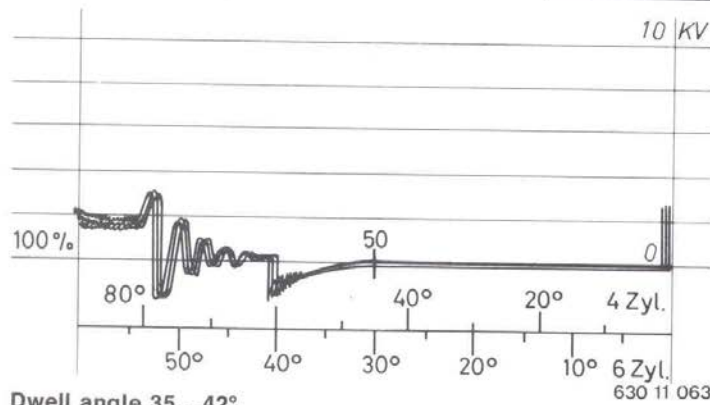
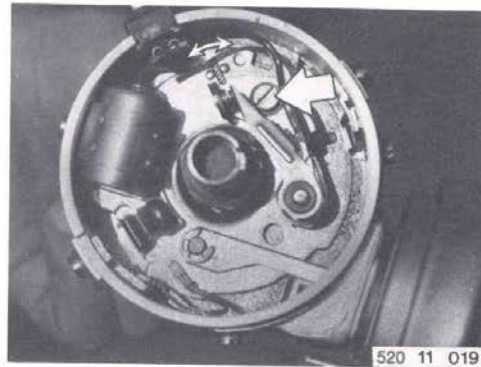

Dwell angle 35...42°.
Adjust dwell angle to smallest value.
This oscillograph shows a correctly adjusted dwell angle.

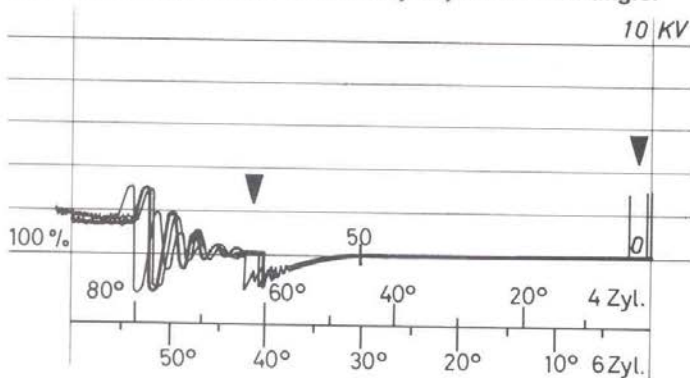

Distributor cam displacement
The ignition patterns of all cylinders are superimposed.
The distributor cam's accuracy will determine the regularity of the successive ignition patterns.
The amount of cam displacement¹⁾ can be read off at the scale in degrees.
Worn cams, a worn distributor shaft or a loose contact breaker plate will cause alterations in dwell angle and ignition timing intervals.
Renew distributor – 12 11 060.

¹⁾ See test values

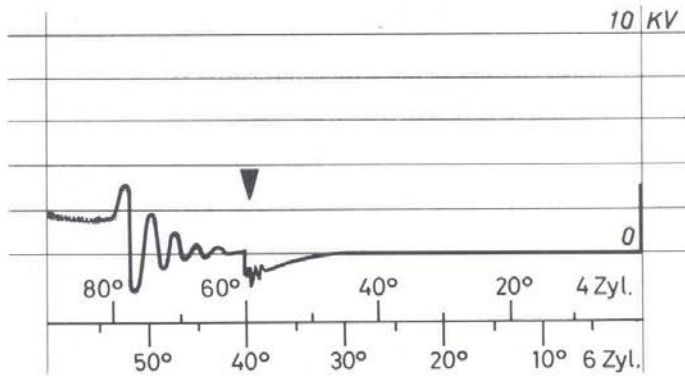

630 11 038

Dirty and burnt contact breaker points

The oscillograph shows this fault by a deformation of the initial dwell phase.
Renew contact breaker points.

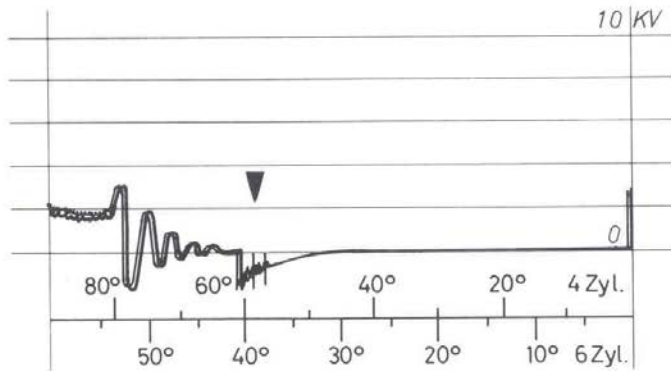

630 11 039

Contact chatter

The contact breaker arm bounces after closing and thus produces another break. Renew contact breaker points.

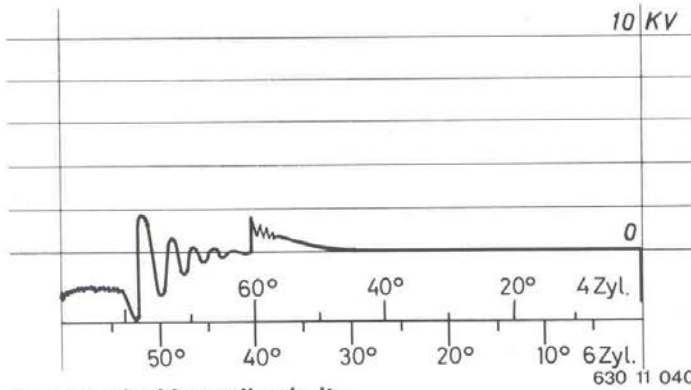

630 11 040

Incorrect ignition coil polarity

Wires have been confused at ignition coil terminals 15 (+) and 1 (-). Correct the wire connections. This refers to the car's wiring and not to the test leads.

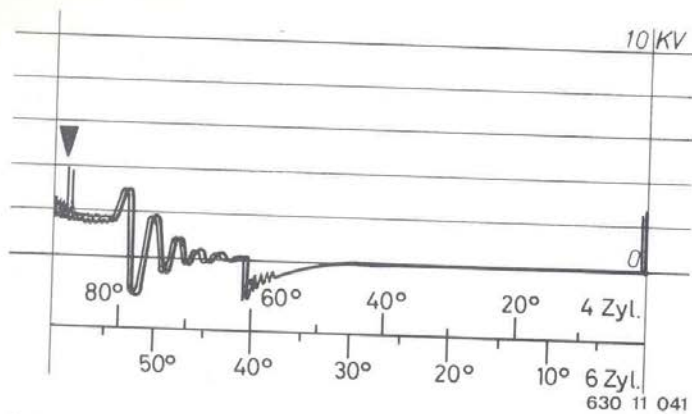

Capacitor series resistance

Capacitor series resistance will cause arcing at the contact breaker points, which turn blue, and the erosion of metal from one contact breaker point to the other.

Important: Capacitor series resistance will retard the ignition timing. It is essential to correct this defect before adjusting the ignition timing. Renew capacitor and contact breaker points.

Checking and adjusting ignition timing

Requirements for exact ignition timing adjustment:

- a) Perfect contact breaker points
- b) Correct dwell angle

Detach vacuum hoses at distributor.
Start engine.

Set BMW digital tester to 1500 min⁻¹ with the speed control button → ←.

Refer also to BMW digital tester operating instructions.

Accelerate engine to at least 1500 min⁻¹.

Read advance (22° ± 0.5') on digital tester.

Correction: Loosen distributor mounting screw and correct ignition timing by turning distributor.

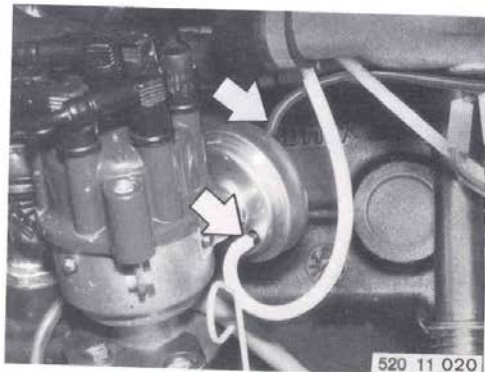



Centrifugal ignition control¹⁾

(engine at operating temperature)
Detach vacuum hoses for advance and retard control. Set BMW digital tester for different speeds (see pages 11-00/19 and 20), and take measurements.

Renew distributor if there is serious deviation from specifications.

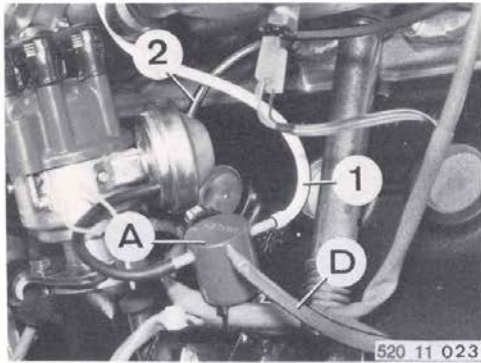

Vacuum ignition control

a) Retard control: Install control valve (A) between vacuum box and hose (1). Connect the control valve connection (D) with vacuum gauge (in program tester). Detach hose (2). Start engine.

Open control valve slowly – vacuum drops. Watch digital tester and read vacuum¹⁾ from gauge as soon as the advance angle reading increases. The value shown on the digital tester is the end of the vacuum control, e.g. 38°. Open valve further until no vacuum is shown. Watch digital tester and shut control valve slowly. Read value from vacuum gauge as soon as the advance angle drops. The value shown on the digital tester is the beginning of vacuum control, e.g. 24°.

b) Advance control: Install control valve (A) between vacuum box and hose (2). Make measurement as in point a).

c) Control angle:

| | |
|------------------------------------|-----------|
| Measured at end of control | 38° |
| – measured at beginning of control | –24° |
| | <hr/> 14° |

¹⁾ See test values

Switch position KV
 Engine speed
 9000 min⁻¹ scale
 1200...1400 min⁻¹



PROGRAMME 630 11 050

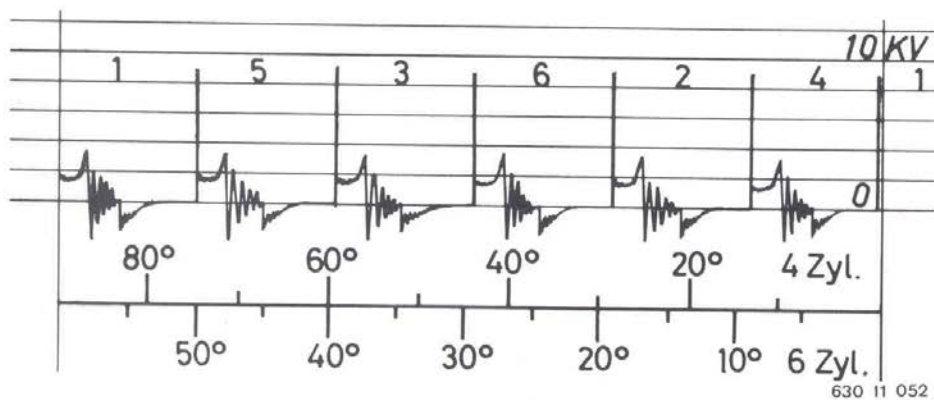

630 11 052

Turn KV rotary switch knob to left stop.
 General view of an ignition system in good condition.
 Cylinders are shown on the screen in firing order.
 Only ignition voltage peak of cylinder number 1 is at far right.

11-00/15

3.78

11-00/15

11-00/15

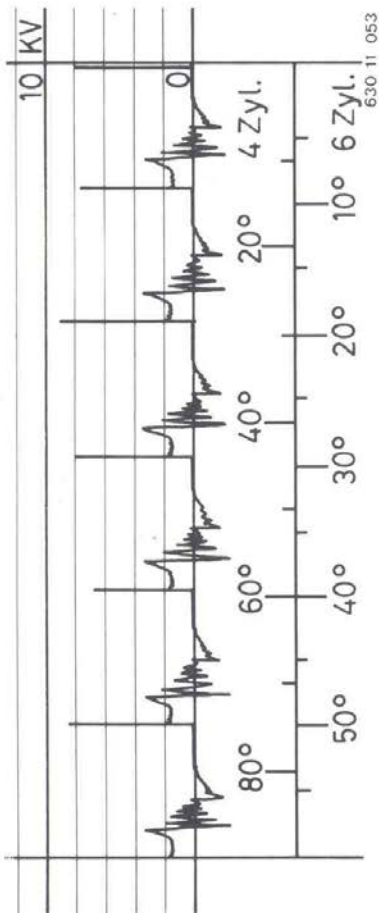

630 11 053

Ignition voltage is measured in KV with an oscilloscope. More important than the amount of ignition voltage is the uniformity for all cylinders. Differences up to 3KV are acceptable. If differences are greater than this, check the following:

- a) Fuel/air mixture setting of carburetor.

| Factors affecting ignition | Ignition voltage too high Cause | Ignition voltage too low Cause |
|--------------------------------------|---------------------------------|-----------------------------------|
| b) Electrode gap ¹⁾ | Large | Small |
| c) Compression | High | Low |
| d) Fuel/air mixture | Lean | Correct |
| e) Ignition spark polarity | Incorrect | Correct (negative ignition pulse) |
| f) Electrode (engine) temperature | Low | High |
| g) Electrode material ¹⁾ | Unsuitable alloys | Special alloys |
| h) Electrode shape ¹⁾ | Round | Sharp-edged |
| i) Electrode condition ¹⁾ | Burnt | New |
| k) Ignition timing | Retarded | Advanced |
| l) Ignition cable | Break | - |
| m) Spark gap in distributor | Large | - |

¹⁾ Determined by spark pulgs

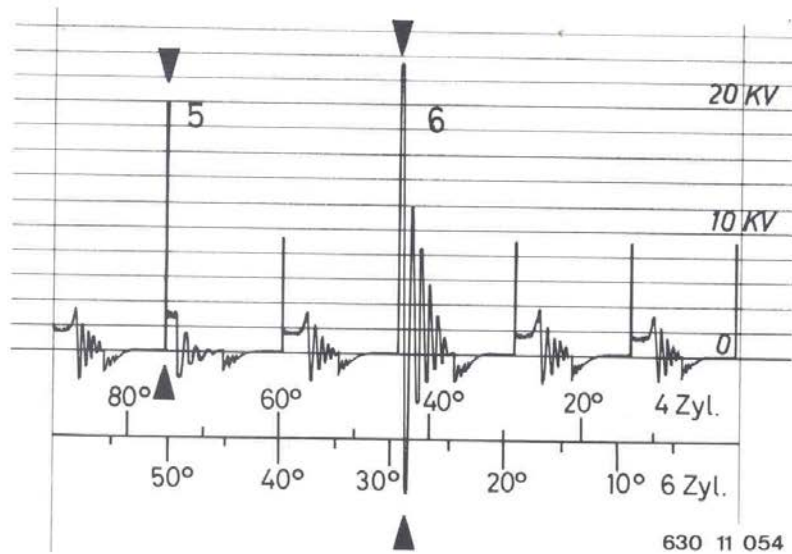

Critical insulation test²⁾

This requires pulling off each spark plug connector one after the other.

Cylinder 6 insulation is in good condition.
Cylinder 5 insulation defective.

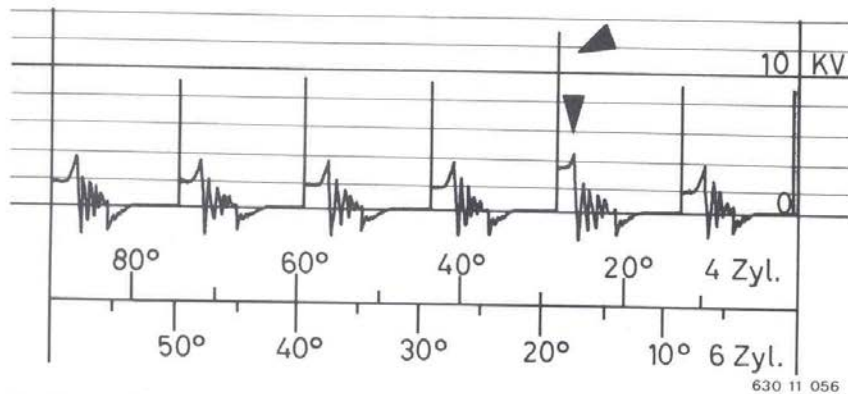

Faults on all cylinders

Suppressor resistors between ignition coil¹⁾, distributor or distributor rotor¹⁾ with too much resistance. Combustion voltage line is at an angle and narrower than usual.

Excessive resistance will be noticed when driving the car by way of poor acceleration and inadequate engine power.

1) See test values

2) *Warning:* Never work on contactless transistorized coil ignition system unless engine is stopped and ignition switched off. Danger of fatal electric shock.

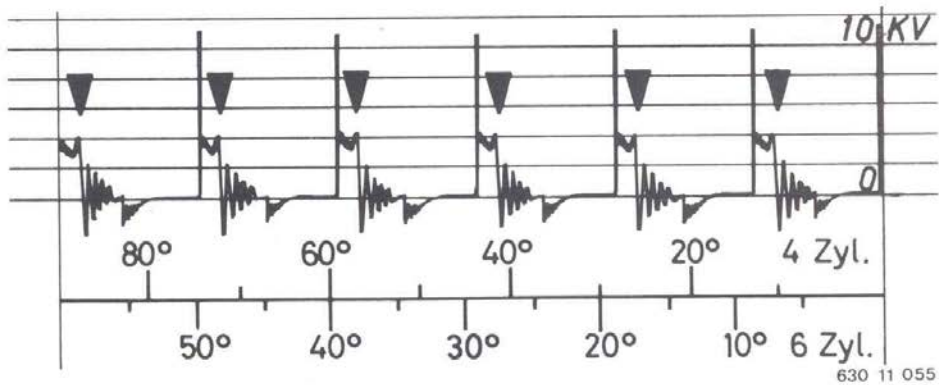

Fault on one ignition cable, spark plug connector or suppressor cap.

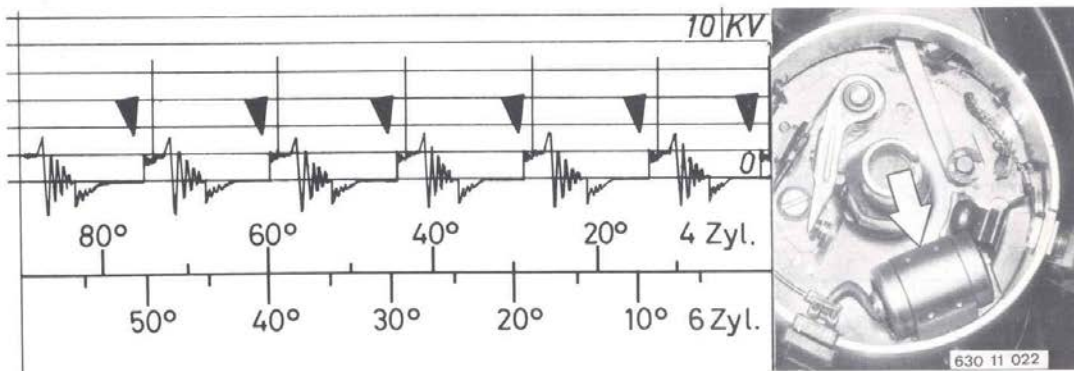

Capacitor series resistance

Important! Capacitor series resistance will retard the ignition timing. This fault must be found and corrected before timing the ignition.

Turn rotary switch knob → to the right until basic image for cylinder 1 appears separately on the screen.

Now turn rotary switch knob ↔ to the left slowly and check the images in the sequence of the firing order (1-5-3-6-2-4).

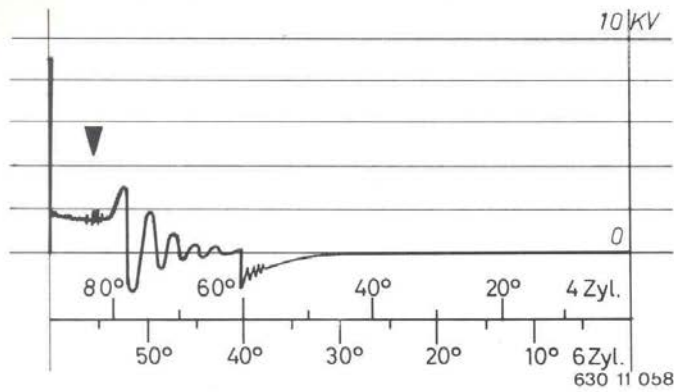

If spark plugs are heavily contaminated, the combustion voltage line will appear thicker than usual and will be superimposed by oscillations.

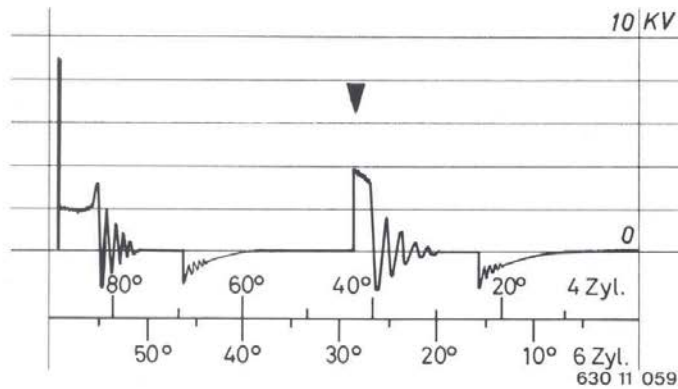

If spark plugs are severely leaded, the ignition current will stray via the electrically conductive lead deposits when the engine is warm. This in turn will cause misfiring.

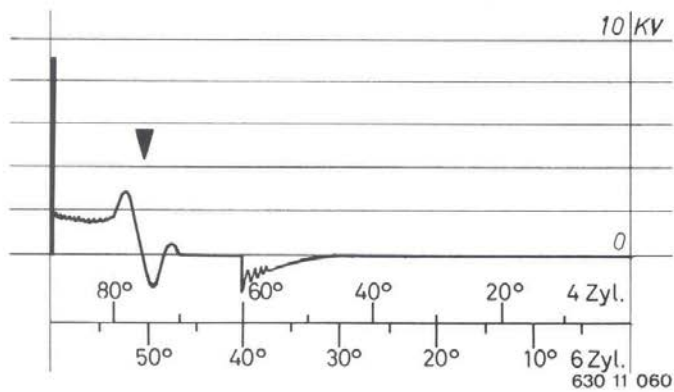

Distributor capacitor is shorted to ground if insulation resistance is below 2 K Ohms. Engine will stop running if there is a complete short to ground.

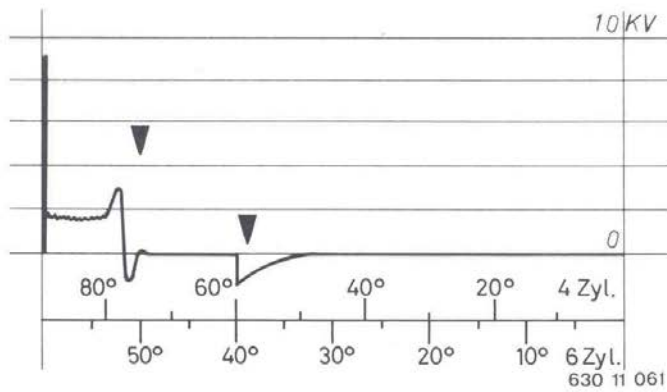

Short in ignition coil primary winding
 Turn back rotary switch knobs → and → to their initial positions (cylinders 1..6 between 0 and 60°).



9000 min⁻¹ scale
 Engine speed approx.
 1200... 1400 min⁻¹

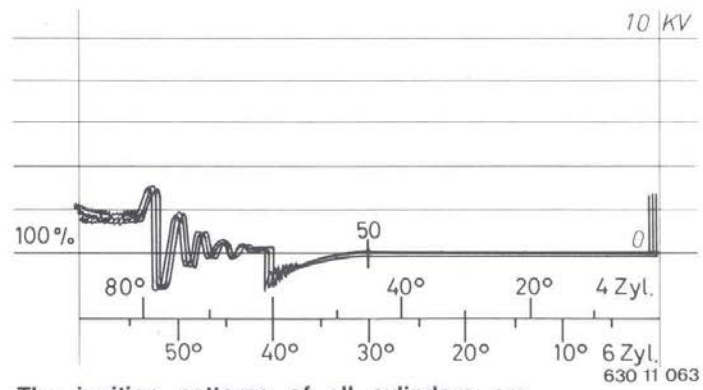

The ignition patterns of all cylinders are superimposed for comparison with each other.

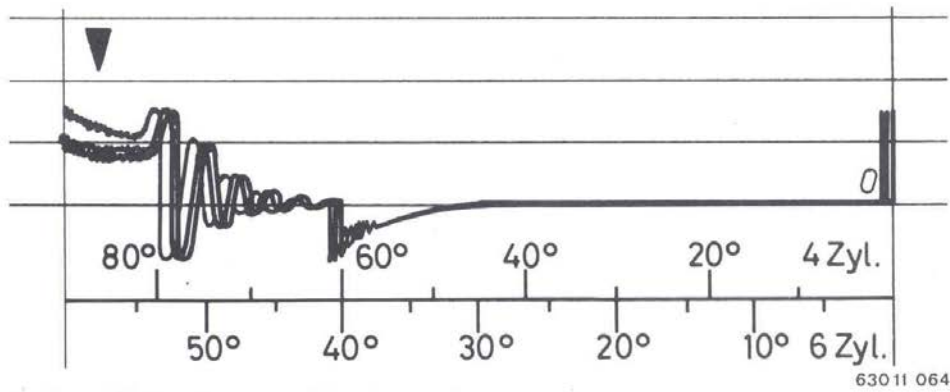

This oscillograph shows that a suppressor resistor for one cylinder is defective.

Set balance switch to O.
 Turn distance rotary switch knob to the right until all
 cylinders appear on the screen.
 The cylinder patterns are superimposed in sequence of firing
 order to permit comparisons.

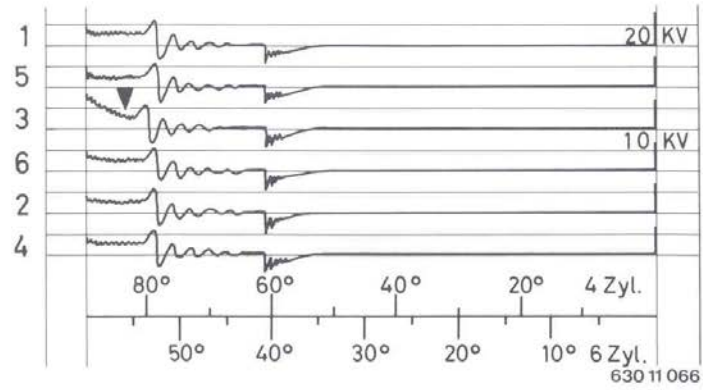
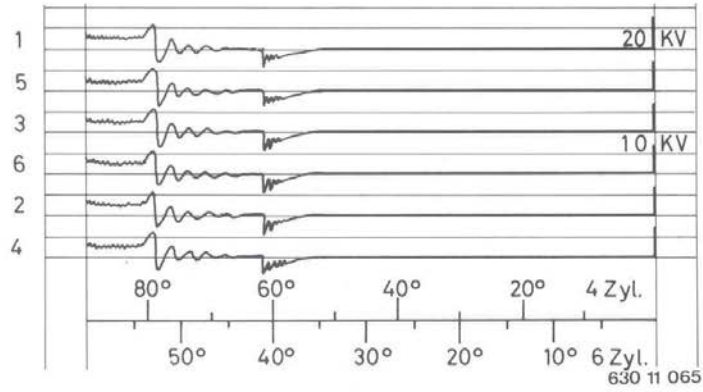

Excessive suppressor resistance at cylinder 3.



PROGRAMM 630 11 067

Switch position balance
2000 min⁻¹ scale
Engine speed 1500 min⁻¹

Power output comparison of cylinders

Important! This test requires perfect carburetor, ignition timing and valve clearance settings.

Adjust cylinders with selector switch (B) one after the other in sequence of firing order, and short circuit each cylinder by pressing button (A). Read speed drop on scale. Speed drops should be as uniform as possible and about 100 min⁻¹ per cylinder.

Check compression if speed drop is lower than this.

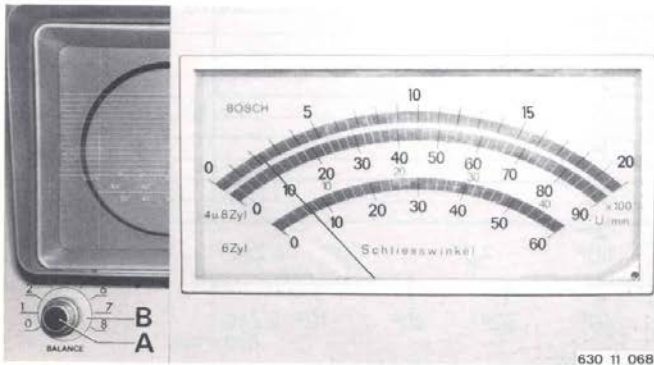

| Switch position | Item tested | Specification | |
|-------------------------------|---|---|---|
| U (B +) | Battery voltage without power consumers | min. 11.8 volts | |
| U (15) | Voltage at ignition coil terminal 15 | min. 10.8 volts | |
| | a) At ignition coil static current b) While starting | min. 9.0 volts | |
| U (1) | Voltage drop at contact breakers and plug | max. 0.3 volts | |
| Rr | Capacitor series resistance | within Rr range | |
| U (D +) | Alternator a) Voltage at D + | 13.5 . . . 14.6 volts | |
| | b) Checked with oscillograph at 900 min ⁻¹ | see page 11-00/7 | |
| Schl. x | Dwell angle | 35 . . . 41° | |
| | Contact opening | ≥ 0.35 mm (0.014 in) | |
| Digital Tester | Cam displacement, checked with oscilloscope at 2000 min ⁻¹ | max. 3° | |
| | | 22 + 1° BTDC | |
| | | Degrees BTDC on crankshaft | |
| | | 10 . . . 15° | |
| | | 22° | |
| Verst. x Digital Tester | Aimed at TDC mark | 2000 | |
| | | 2500 | |
| | | 3000 | |
| | | 3500 | |
| | | 31 . . . 37° (end) | |
| Digital Tester | Distributor No.: 0 231 309 007 | Retard 50 . . . 80 | |
| | | Retard 92 . . . 105 | |
| | | Retard 8° . . . 12° | |
| KV | Vacuum control | Begins Advance 110 . . . 140 | |
| | | Ends Advance 175 . . . 185 | |
| | Control range at crankshaft | Advance 8° . . . 12° | |
| | | Retard control at idle speed | 150–200 min ⁻¹ |
| | Speed boost with hose detached | Ignition voltage at 1 200 . . . 1 400 min ⁻¹ | |
| | | Difference in ignition voltage of individual cylinders | 8 . . . 14 KV |
| | Increase when accelerating | Ignition voltage at 1 200 . . . 1 400 min ⁻¹ | |
| | | Ignition coil idle voltage (plugs off) | 2 . . . 3 KV |
| | Bal. | Output comparison of cylinders at 1 000 min ⁻¹ | min. 18 KV |
| | | | Engine speed must be as constant as possible |
| I CO % | Exhaust test at 850 ± 50 min ⁻¹ | 1 ± 0.5% by volume | |
| | | Fuel pump pressure | 0.20 . . . 0.30 kp/cm ² (2.8 . . . 4.2 lb/in ²) |

Program test – BMW 323 i

| Switch position | Item tested | Desired value |
|-----------------|---|---|
| U (B +) | Battery voltage without consumers | min. 11.8 V |
| U (15) | Voltage at coil terminal 15 | |
| | a) off-load coil current | min. 10.8 V |
| | b) during starting | min. 9.0 V |
| U (1) | Voltage at coil terminal 1 or control unit terminal 16 | below 2.0 V |
| U (D +) | Alternator | |
| | a) Voltage at D + | 13.5 – 14.6 V |
| | b) Oscilloscope test at 900 min ⁻¹ | see page 11-00/7 |
| Digital tester | Dwell angle | at min ⁻¹ 1 500 4 500 |
| Digital tester | Ignition at 1 500 min ⁻¹ without vacuum control | 22° bTDC |
| Verst. ✕ | Centrifugal ignition control (without vacuum ignition control) | min ⁻¹ °CS bTDC |
| Digital tester | Distributor No. 0 237 302 006 | 1 000 |
| | | 1 500 |
| | | 2 400 |
| | | 4 000 |
| Digital tester | Vacuum ignition control | retard 140 ... 290 mbar |
| | Begins | retard 450 ... 540 mbar |
| | Ends | retard 14 ... 18 |
| | Control range °CS | 6 ... 11 kV |
| kV | Ignition voltage at 1 200 ... 1 400 min ⁻¹ | 2 ... 3 kV |
| | Variation in ignition voltage between cylinders | 2 ... 3 kV |
| | Increase when throttle is opened | min. 18 V |
| Bal. | Coil off-load voltage (spark plug caps detached) ¹⁾ | Running speeds must be as uniform as possible |
| | Comparison of cylinder power output at 1 000 min ⁻¹ | 1.5 ± 0.5% CO by volume |
| I CO % | Exhaust emissions test at 900 ± 50 min ⁻¹ | 0.20 – 0.30 kp/cm ² (2.8 ... 4.2 lb/in ²) |
| | Fuel pump pressure (vacuum hose to pressure regulator detached) | |

1) Warning: no work to be done on contactless transistorized coil ignition system unless engine is stopped and ignition switched off.
Danger of fatal electric shock.

Additional test

Voltage resistance and capacitance tests can also be made with the test lead via the range switch. These tests can be made at any program switch position; this will not impede the other programs – except the voltmeter.

Voltage test

Set range switch to X 1 V or X 0.1 V depending on test range.

Test lead connections: red clip to +
black clip to –

Capacitance test

Set range switch at X 1 μ F or X 0.1 μ F depending on test range.

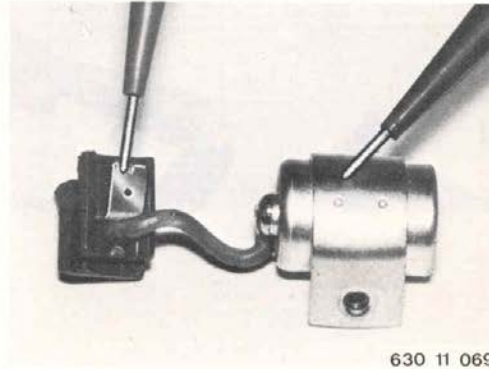

630 11 069

Important! For capacitance tests never short circuit or supply voltage to test terminals. Built-in capacitors must be disconnected before testing.

Connect capacitor between clips of test lead. Read test value¹⁾ on instrument.

Note! Capacitors which were not used for a long time or are new must be charged and discharged before testing. Otherwise the series resistance shown will be too high, but will disappear immediately after being put in operation.

1) See test values.

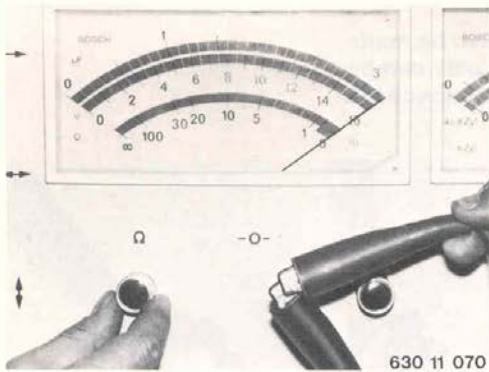

Resistance test

Set range switch at X 1 Ohm or X 1 KOhm depending on test range.

Calibrate the applied test range before each test.

Short circuit test terminals.

Set needle of instrument at 0 (bottom scale) with rotary switch knob for Ohms (Ω).

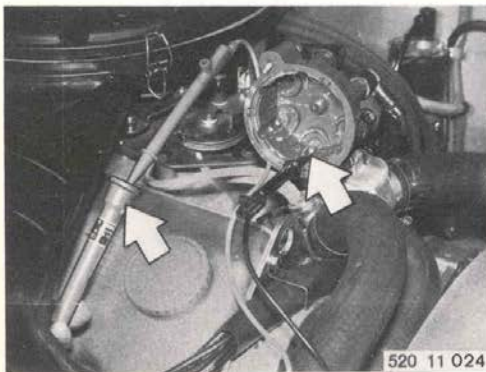

Connect resistor¹⁾ between clips of test lead and read amount of resistance.

The degree of insulation is better, the higher the insulation resistance. Normally the instrument needle in test range X 1 KOhm will deflect completely when insulation is perfect, i.e. infinite resistance.

Important!

Never supply voltage to test terminals.

0.25 ampere fuse on front of tester, right-hand side.

¹⁾ See test values

¹⁾ See test values

Test values for additional test

| Charge condition | Acid density g/cm ³ | Idle speed voltage per cell in volts | At least 12.2 volts |
|---|-----------------------------------|---|---------------------|
| Full | 1.28 | 2.12 ... 2.13 | 12.72 ... 12.78 |
| Half | 1.20 | 2.05 | 12.3 |
| Dead | 1.12 | 1.97 ... 1.98 | 11.82 ... 11.88 |
| Voltage at ignition coil terminal 15 or at input to series resistor | | | |
| a) At ignition coil static current | | | |
| b) While starting | | | |
| Voltage drop at contact breakers and plugs | | | |
| Voltage at alternator D + | | | |
| Voltage B + to starter 30 | | | |
| B + to ignition coil 15 or series resistor input | | | |
| B - to engine ground | | | |
| Suppressor resistance ¹⁾ | | | |
| Distributor rotor | | | |
| Suppressor cap in distributor cap | | | |
| Plug connectors | | | |
| Distributor capacitor ¹⁾ at TSZ No. 1 237 330 303 | | | |
| Insulation resistance | | | |
| Ignition coil ¹⁾ Bosch No. 0221 119 017 KW 12 V | | | |
| 0221 122 010 at TSZ (= transistorized coil ignition) | | | |
| Cable series resistance | | | |
| 1) Values at ... 20°C (... 68°F). | | | |

11 00 039 Compression test on all cylinders

On 323i only:

To prevent the cylinders from becoming flooded with fuel by the injectors delivering fuel continuously as the starter is run, the fuel pump relay (1) or diode relay (2) must be removed.

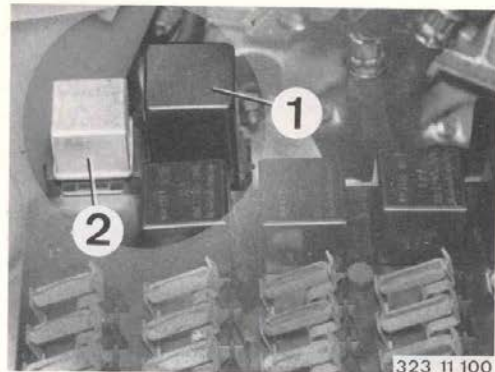

Remove the spark plugs.
Check compression¹⁾.



11 00 050 Engine – removing and installing

Remove gearbox – 23 00 020
or automatic transmission – 24 00 020.
Take off the engine compartment lid –
41 61 000.
Remove the air cleaner – 13 71 000.
Remove the radiator – 17 11 000.
Remove the coolant equalizing tank.



Detach the positive and negative leads from
the battery.
Take off cable (1).

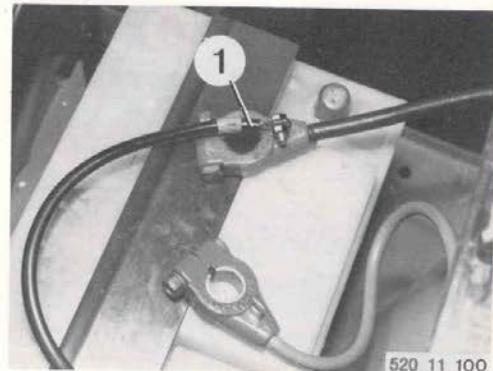

¹⁾ See specifications

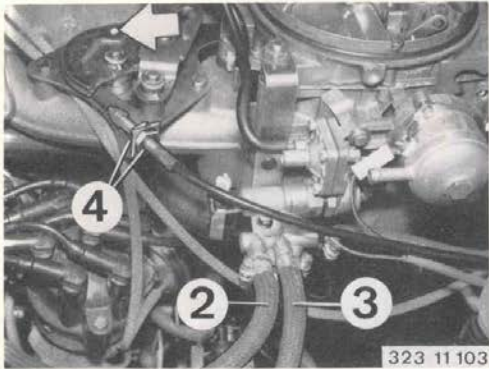

Carburetor engine:

Detach fuel hoses (2) and (3).

When installing: do not accidentally confuse these hoses.

Hose (2): fuel supply; hose (3): fuel return.

Unscrew nuts (4) and disconnect the accelerator cable.

When installing: adjust the accelerator cable – see 35 41 421.

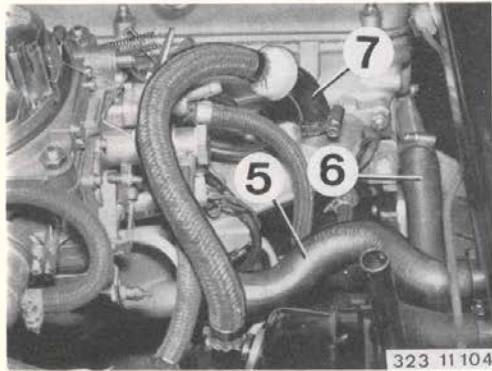

Detach coolant hoses (5) and (6).

Disconnect vacuum hose (7).

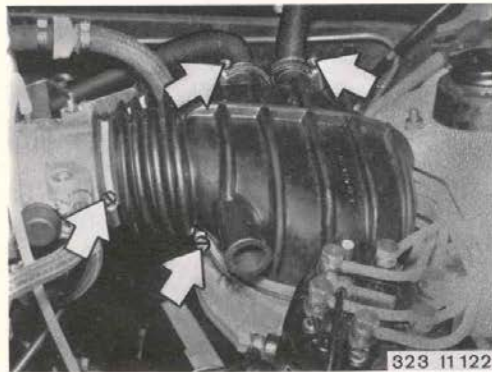

Fuel injection engine:

Take off the intake air scoop.

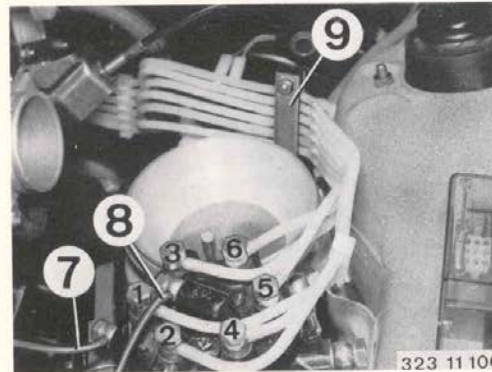

Detach injector lines (1... 6).

Detach fuel lines (7) and (8).

When installing: do not accidentally confuse these lines.

Line (7) to cold-start valve, line (8) to warming-up sensor.

Check condition of sealing rings and renew if necessary.

Release holder (9).

Detach fuel lines (10... 12).

When installing: line (10) to warming-up sensor, line (11): fuel supply, line (12): fuel return. Loosen nuts and take the mixture regulator with air cleaner housing out upwards.

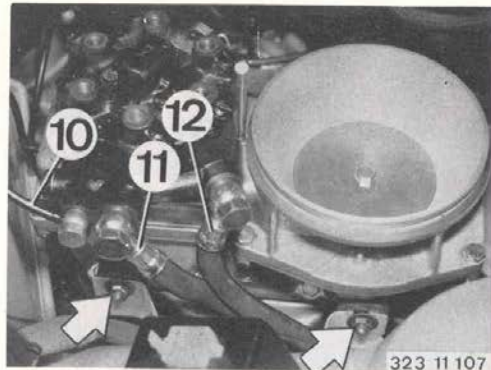

When installing: the rubber underlay must be in the funnel on the air cleaner housing.

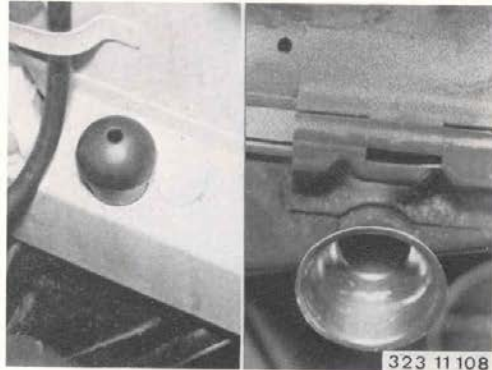

Detach the accelerator cable and remove it from the reaction bearing.

When installing: adjust accelerator cable – see 35 41 421.

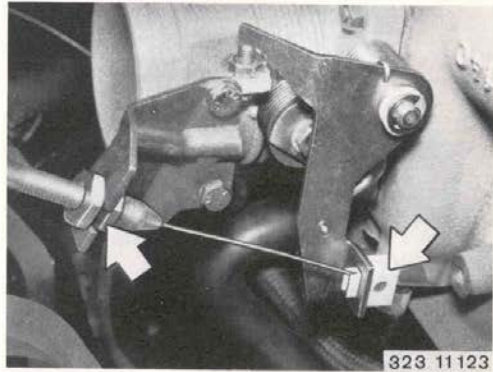

Detach coolant hoses and vacuum hose.

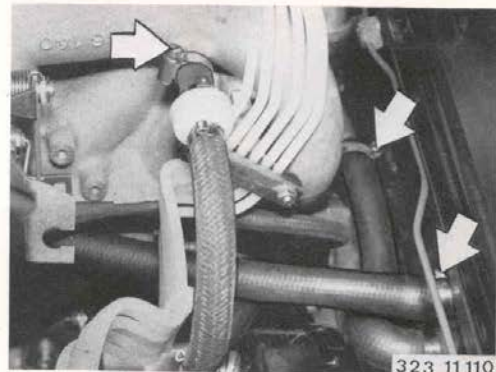

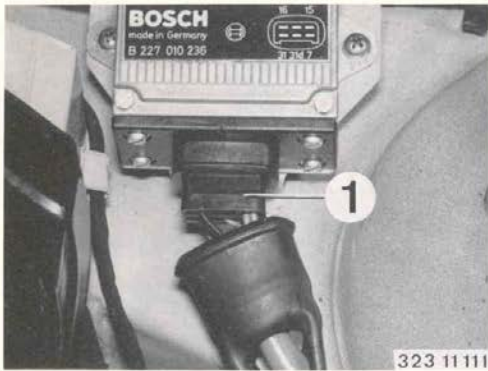

**Pull off the protective cap.
Pull out plug (1).**

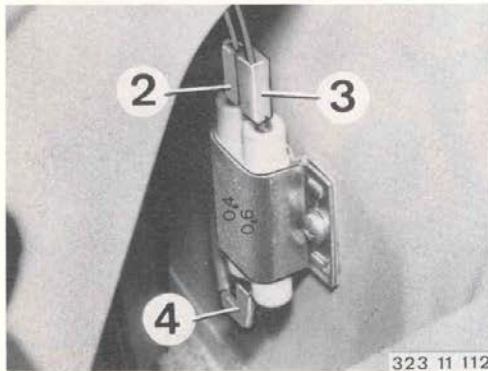

Pull off leads (2...4).
When installing: **black/red and green to 0.4
Ohm
black/red to 0.6 Ohm**

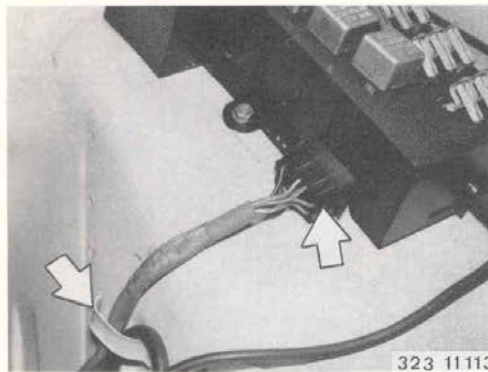

**Detach the multi-pin plug.
Lift the wiring harness out of its clip on the
wheel arch.**

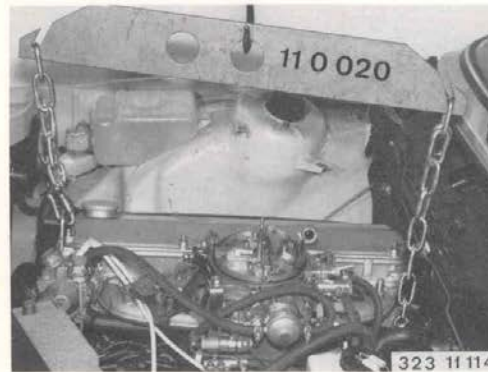

**Suspend the engine from engine lifting beam
11 0 020 at front and rear.**

Detach earth (ground) strap (5) and left engine mounting.



Detach right engine mounting.

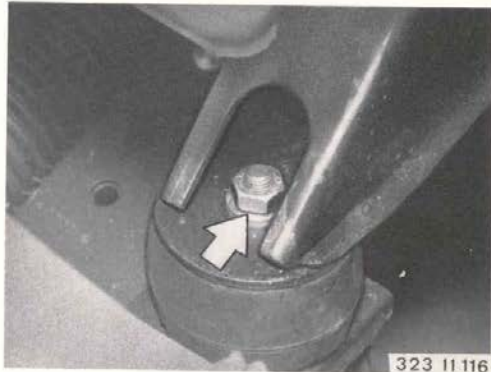

Raise the engine and lift out towards the front.

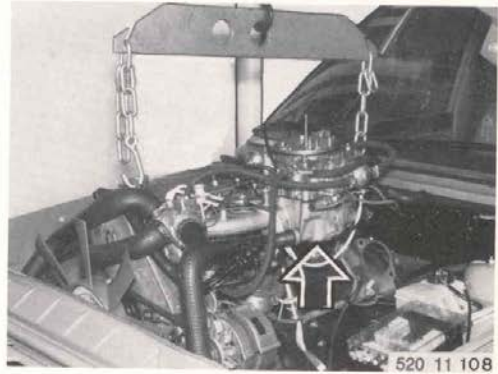

Sectional view of carburetor engine

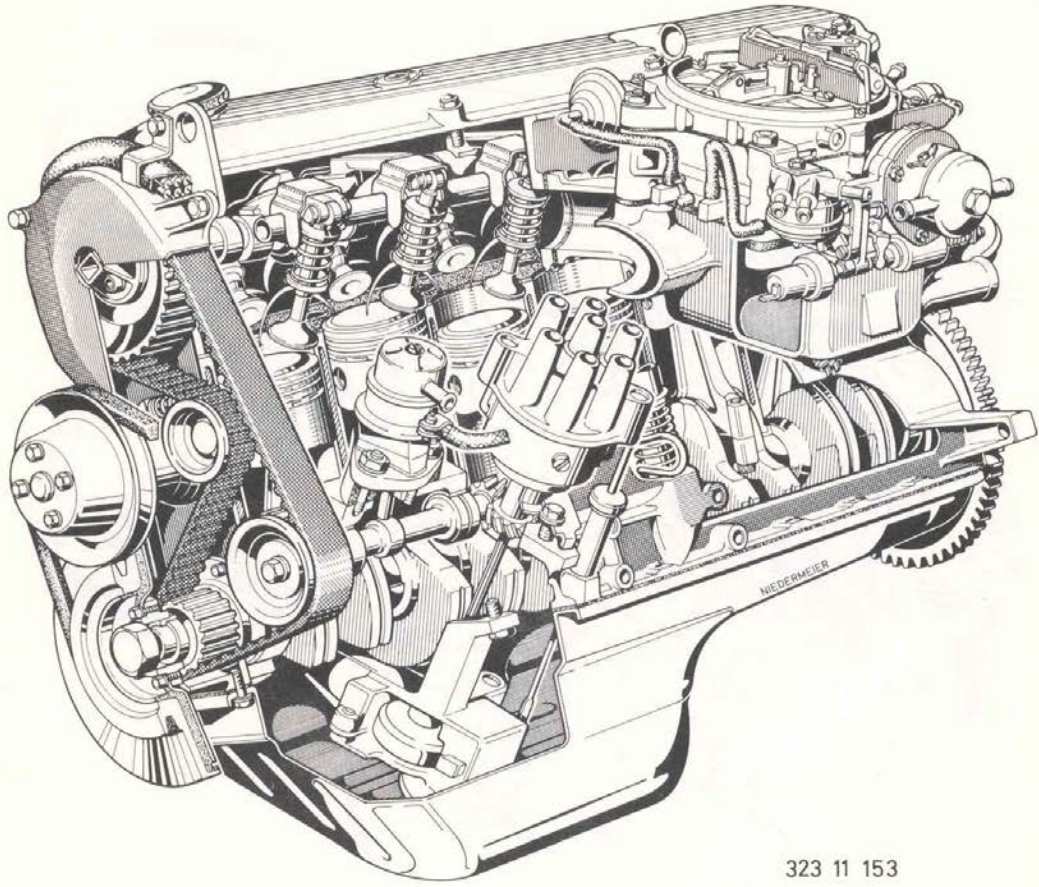

323 11 153

Sectional view of fuel injection engine

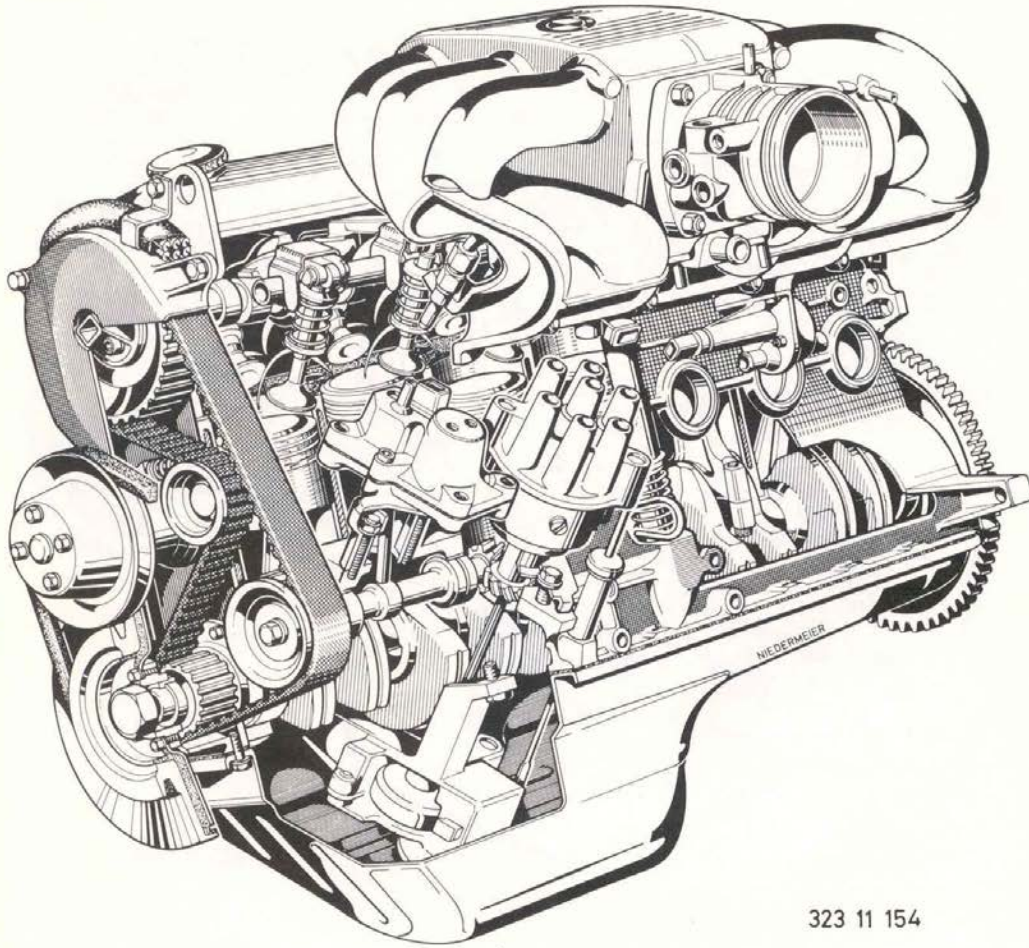

323 11 154

11-00/36

**11 11 160 Distributor shaft bearing – re-
newing**

Remove oil pump – 11 41 000.

Remove distributor – 12 11 060.

**Remove needle bearing by driving it out from
bottom to top with special tool 11 1 310.**



**When installing: Lubricate needle bearing.
Drive in needle bearing up to stop with special
tool 11 1 300.**

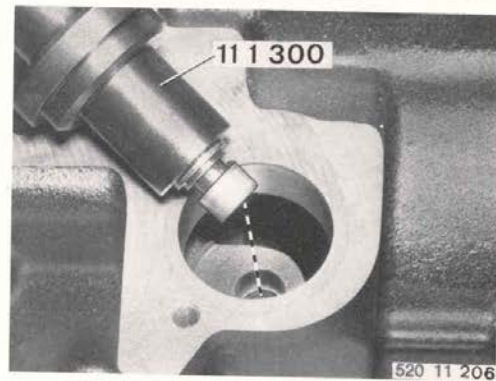

11 12 000 Rocker cover – removing and installing

Remove the air cleaner – 13 71 000.
Slacken nuts (1 ... 8).

Warning: take off spring washers.

Take off the rocker cover.

When installing: tighten nuts in the order 1 to 8 as shown.

Check condition of gasket and renew if necessary.

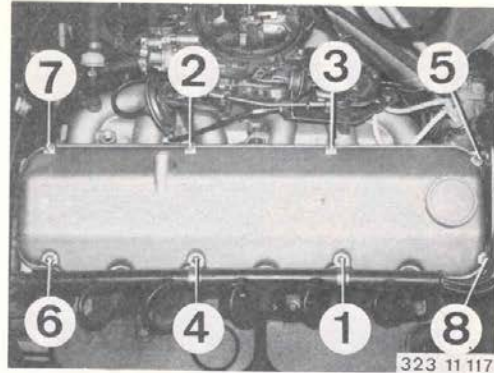

11 12 100 Cylinder head – removing and installing

Detach exhaust pipes from exhaust manifolds.
Detach the exhaust pipe support.

When installing: install exhaust pipe support without trapped stresses.

Remove rocker cover – 11 12 000.

Drain the coolant.

When installing: bleed the cooling system – 17 00 039.

Disconnect the negative lead from the battery.

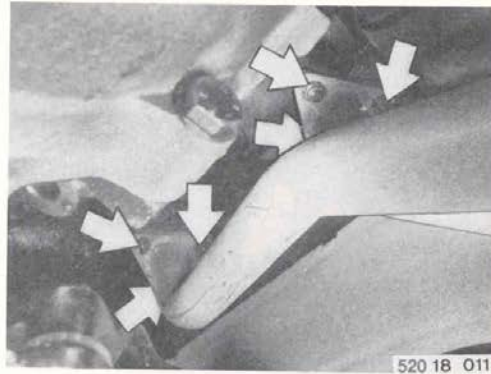

Carburetor engine:

Detach coolant hoses (1 ... 3).

Detach leads (4) and (5).

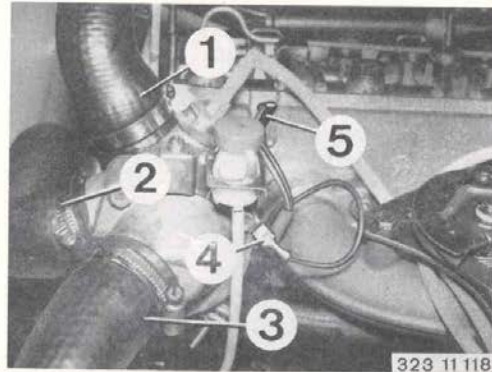

Detach fuel hoses (6) and (7).

When installing: do not accidentally confuse these hoses.

Hose (6): from fuel pump

Hose (7): to tank

Detach leads (8) and (9).

When installing:

green/violet lead to servo motor

green/black lead to choke housing

Disconnect the accelerator cable and remove from reaction bearing.

When installing: adjust accelerator cable – 35 41 421.

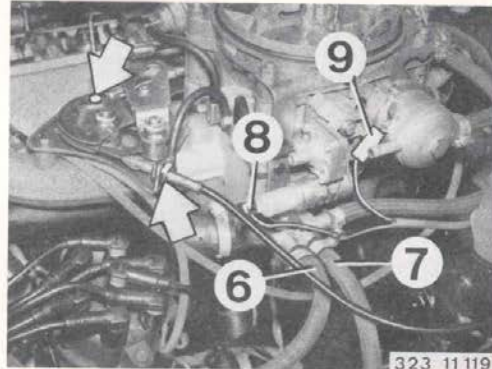

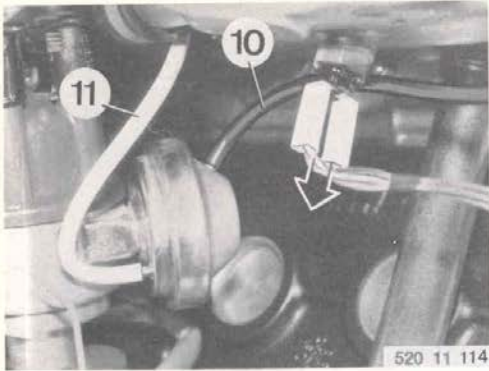

Pull off vacuum hoses (10 and 11).
Detach lead from heat-sensitive switch.

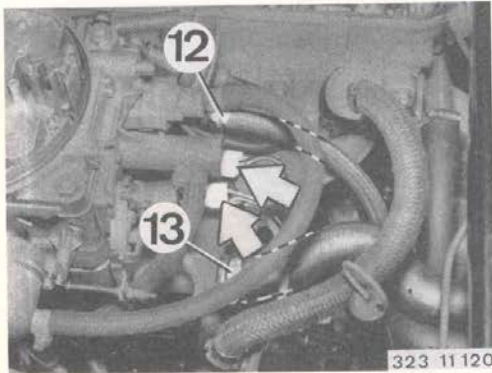

Detach coolant hoses (12 and 13).
Detach the plugs from the idle shutoff valves.

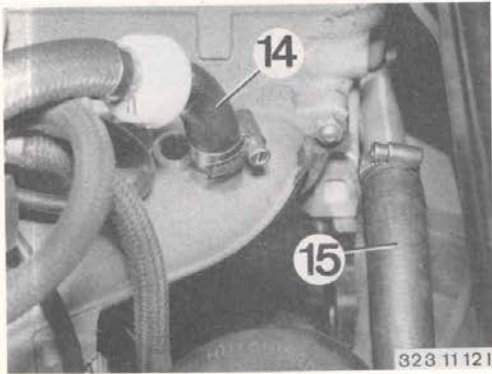

Detach the vacuum hose (14) and coolant hose (15).

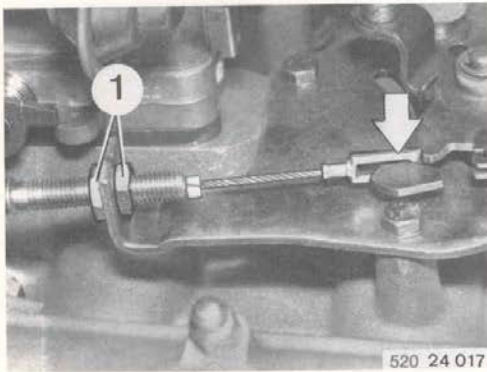

Unscrew nuts (1).
Disconnect the throttle position cable.
When installing: adjust the throttle position cable – see 24 00 004.

Unscrew nuts (1) and pull throttle cable out downwards through the hole in the intake pipe.

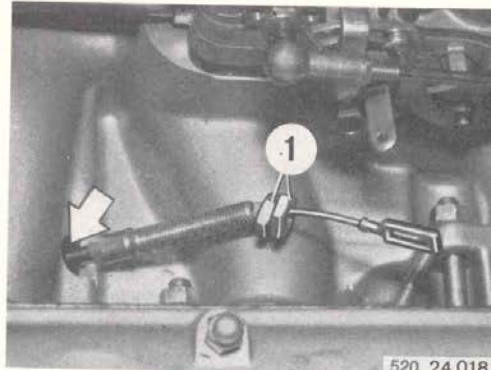

Fuel injection engine:

Take off the air intake scoop.

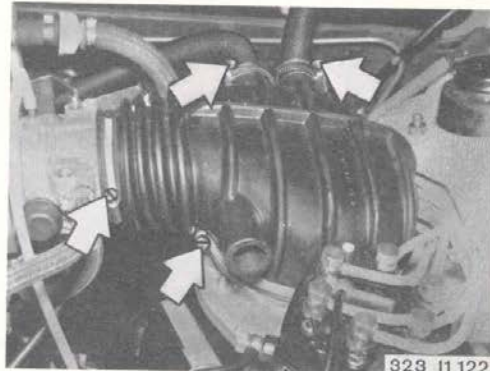

Disconnect the accelerator cable and remove from its reaction bearing.

When installing: adjust the accelerator cable – 35 41 421.



Detach injector pipes 1 ... 6 from the mixture regulator.

Check condition of sealing rings and renew if necessary.

Detach fuel line (7).

Take off holder (8).

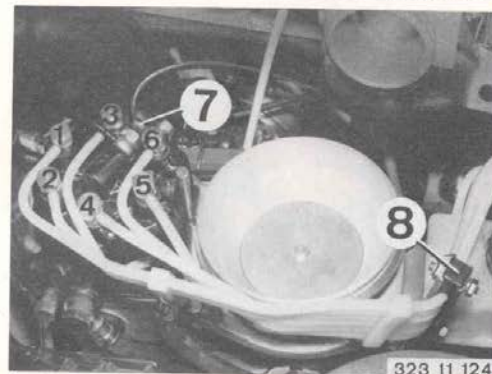

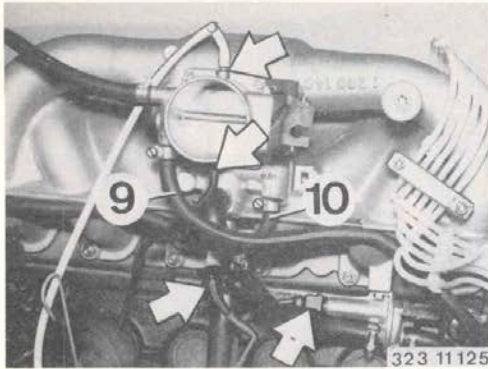

Detach hoses (9) and (10).
Lift hoses away from clips.
Pull off vacuum hoses.
Pull plug away from cold-start valve and from
additional air slide.

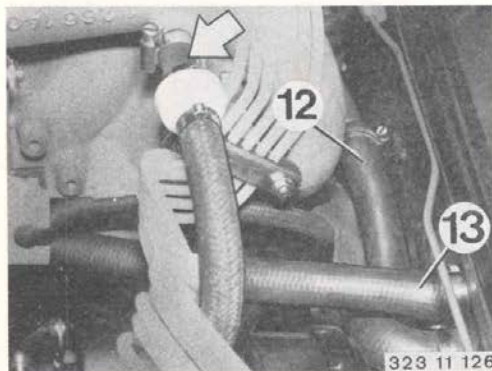

Detach coolant hoses (12) and (13).
Detach vacuum hose from air collector.

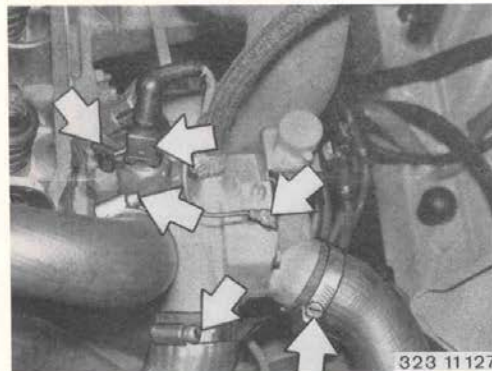

Detach coolant hoses from branch flange.
Pull off plug and lead.



Detach the spark plug caps.
Take off the distributor cap.
Detach the ignition lead.

Remove bolt (1).

Take off belt pulley.

Take off V-belt.

When installing: adjust V-belt to correct tension.

It should be possible to depress the V-belt by 5 ... 10 mm (0.2 ... 0.4 in) at the center of its run. Lift the position indicator out of its clip.

When installing: check that position indicator is correctly located.

Gap between position indicator and vibration A = 0.2 ... 2.0 mm (0.008 ... 0.08 in).

Detach the vibration damper from its hub.

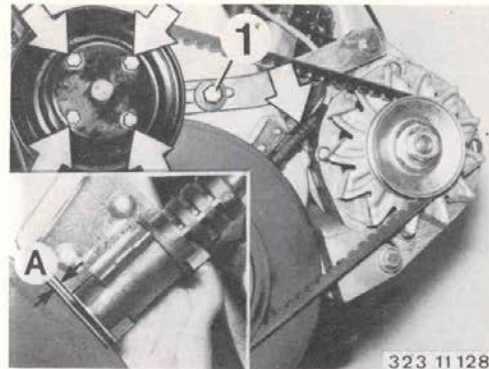

Warning: engine must not be turned over at the adapter unless the spark plugs have been removed.

Set the piston in cylinder 1 to TDC, so that the engine speed governor is aligned with the notch in the distributor body.

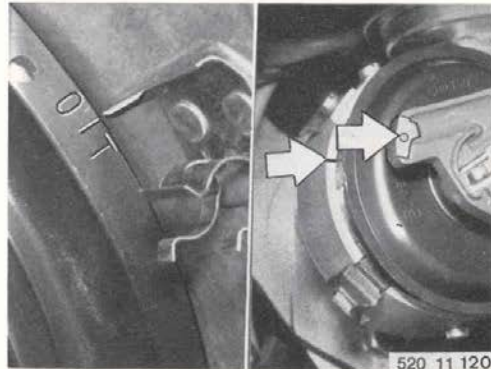

Remove the protective cover.

When installing: attach the suspension eye (2) at the same time.

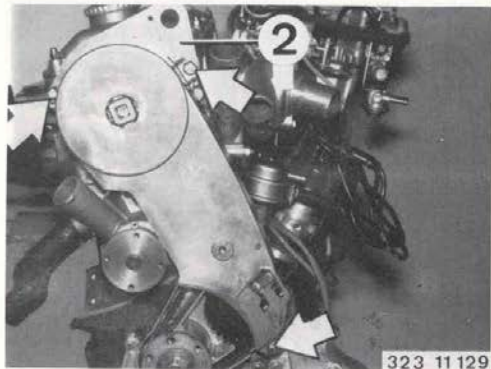

Loosen bolts (13) and (14).
Press the tensioning pulley inwards.
Tighten bolt (13).

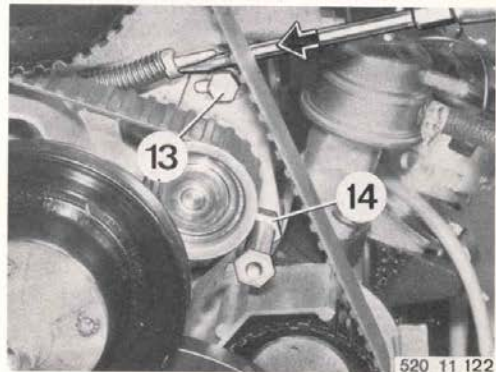

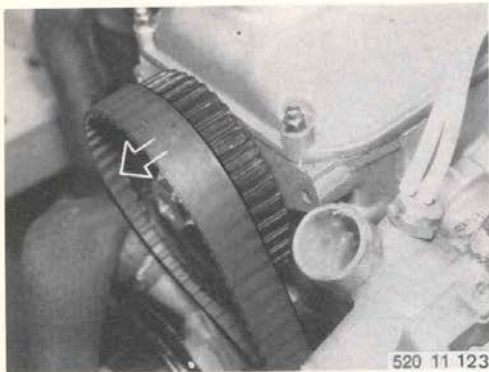

Take toothed belt off camshaft sprocket.

Important: Engine must not be turned without the toothed belt.

When installing: Check TDC position of crankshaft, camshaft and position of distributor.

Tighten toothed belt – 11 31 100.

Check toothed belt and renew if necessary – 11 31 110.

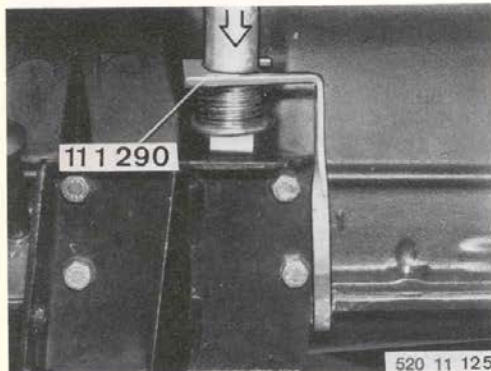

Press down balance tube and lock with special tool 11 1 290.

When installing: Check seals and renew if necessary.

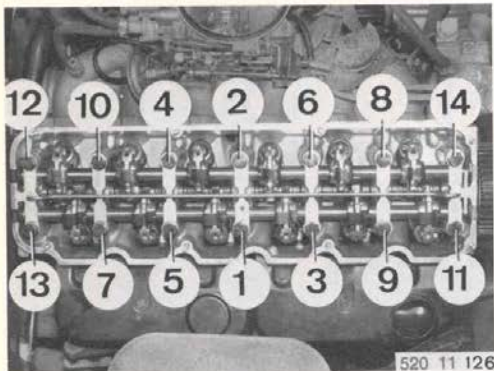

Take off cylinder head.

When installing: Tighten bolts in sequence 1... 14 one after the other in three steps¹⁾.

Run engine to operating temperature. After test run, let engine cool down to 35°C (95°F).

Tighten cylinder head bolts to final torque.

After driving a distance of 1000 km (600 miles) the cylinder head bolts have to be retightened.

Important! There must not be any oil in the cavities, since otherwise the bolts will not give full pressure on the cylinder head in spite of being tightened to the proper torque.

Furthermore the crankcase could crack.

When installing: Clean cylinder head bolts and lubricate threads lightly with oil. The cylinder head gasket must always be renewed.

Adjust valve clearance – 11 34 004.

Adjust engine idle speed/test CO level – 13 00 054.

1) See specifications

11 12 101 Cylinder head gasket – renewing

**Remove cylinder head – 11 12 100.
Clean sealing surfaces on cylinder head and crankcase thoroughly.**

When installing: Use only original cylinder head gaskets since the coolant openings have to be exact.

When installing: If necessary, grind cylinder head sealing surface – 11 12 719.



520 11 127

11 12 240 Radial seal in timing case cover – renewing

**Remove toothed belt – 11 31 110.
Take off adaptor.**

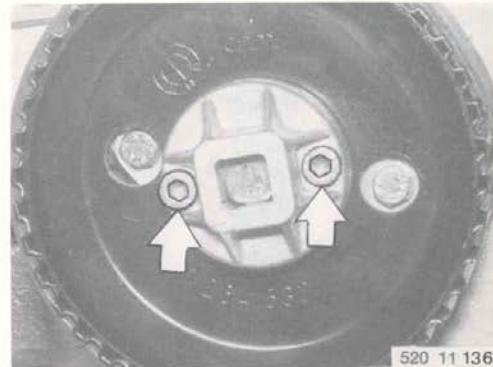

520 11 136

**Take toothed belt wheel off camshaft.
When installing: Cylindrical pin (1) must fit in hole in toothed belt wheel.
Note correct tightening torque¹⁾.**

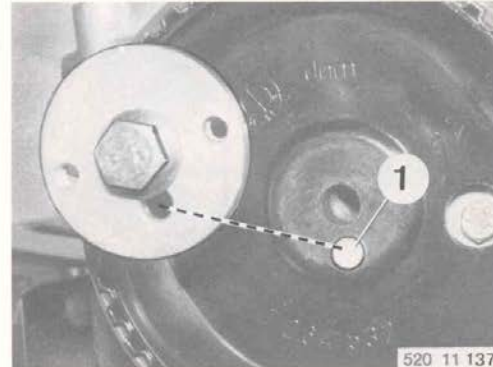

520 11 137

**Take off guide cover.
Replace radial seal and round cord seal.**



520 11 138

¹⁾ See specifications



When installing: Use special tool 11 2 212 to install the guide cover.

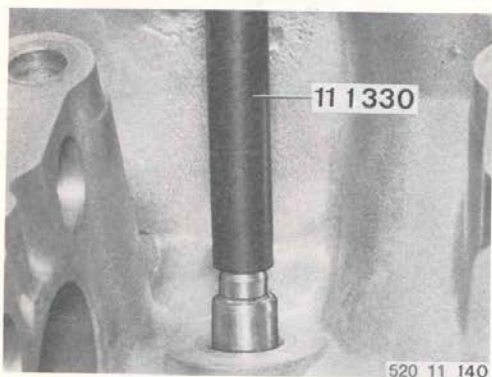

11 12 561 One valve guide – renewing – valve removed –

Drive out valve guide in cold state with special tool 11 1 330 into combustion chamber.

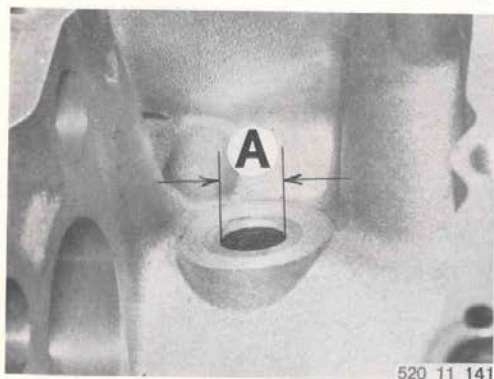

Check bore in cylinder head. If max. permissible diameter A has been exceeded, ream out the bore and install an oversize¹⁾ valve guide. Heat cylinder head¹⁾.

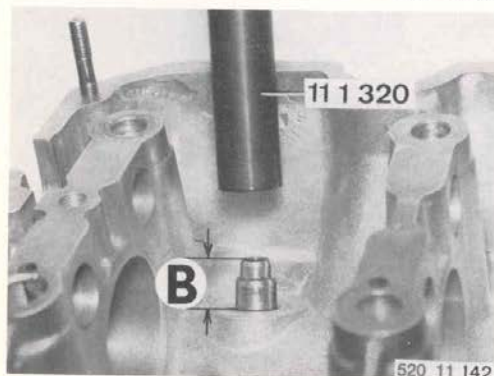

Drive valve guide into combustion chamber from camshaft end with special tool 11 1 320. Stepped end of valve guide faces camshaft.

Important: Bore in special tool determines the installed depth B of 14.5 ± 0.5 mm ($0.571 \pm 0,020$ in). Ream out valve guide to diameter 7H7.

¹⁾ See specifications

11 12 607 Valve seats and valves – machining – cylinder head disassembled –

Note minimum edge thickness A^1) and valve seat angle B . Valve must be replaced when edge thickness is below specification.

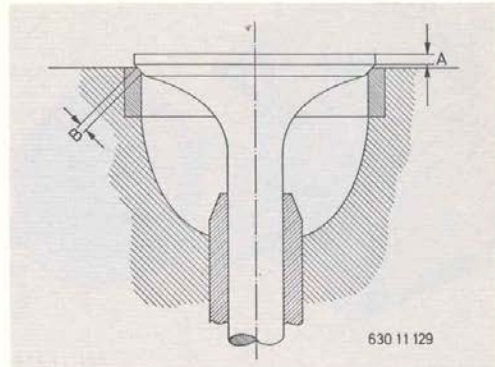

Machined valve seats must not have chatter marks.

Bed in valves with grinding paste.

When installing: Check valves for leaks – 11 34 509.

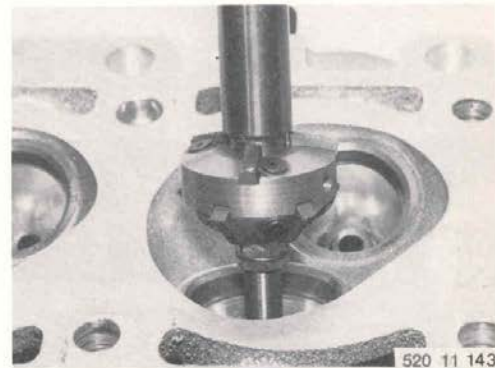

11 12 719 Cylinder head sealing surface – refacing – cylinder head disassembled –

When machining the cylinder head sealing surface not more than 0.3 mm (0.012 in) must be removed from the total cylinder head original thickness A of 125.1 ± 0.1 mm (4.925 ± 0.004 in).

Important: Use stronger sealing at refaced cylinder head.

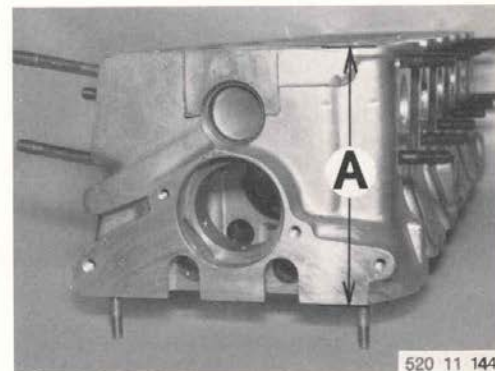

11 12 729 Cylinder head water leak test – cylinder head disassembled –

Bolt rails 11 1 021 on to cylinder head (use cylinder head bolts).

Plug water circuit on cylinder head with sealing plates 11 1 023, 11 1 024 and 11 1 025.

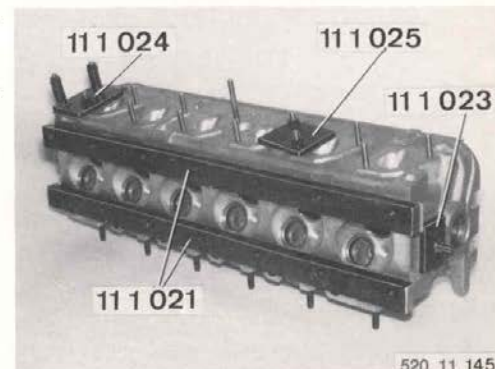

1) See specifications

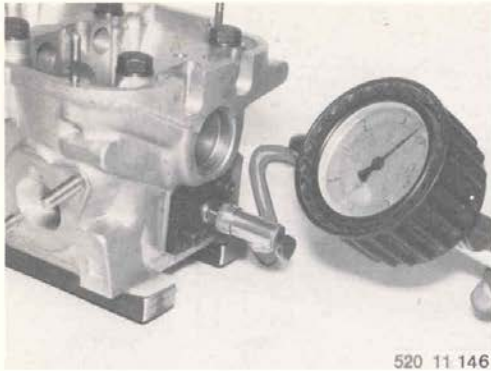

**Pump compressed air into cylinder head.
Test pressure 1.5 bar (21 lb/in²). Place cylinder
head in a water bath and check for cracks.**

520 11 146

11-12/10

11-12/10

11 13 000 Oil sump – removing and installing

**Remove guard.
Drain oil.
Take off sump.**



**Tilt down sump.
Remove pressure relief valve (1) and oil pump (2).
Remove oil sump towards front.
When installing: use a new gasket.**

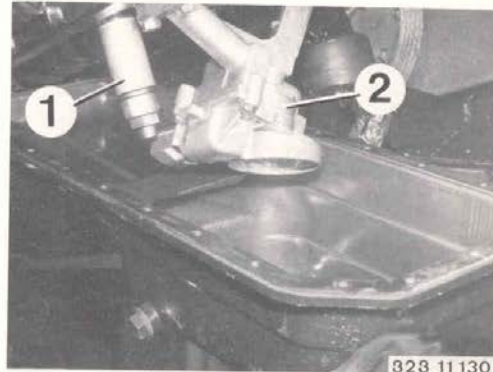

**When installing: Clean sealing surfaces.
Coat mating surfaces on timing case cover and end cover with Atmosit or Curil K 2.**

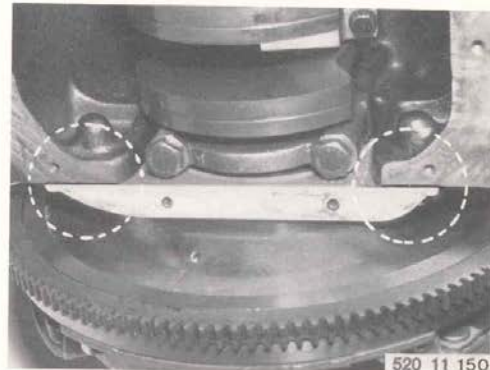
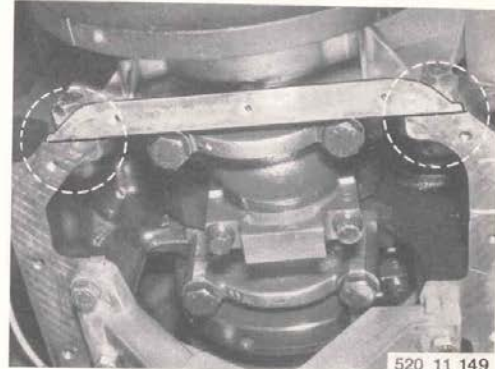

11 14 175 Front end cover – removing and installing

Remove radiator – 17 11 000.

Remove bolt (1).

Detach V-belt pulley.

Remove V-belt.

When installing: tension V-belt correctly.

The V-belt must yield by 5 ... 10 mm (0.2 ... 0.4 in) when pressed in at the center of its run.

Extract the position indicator from its clip.

When installing: check that position indicator is correctly located. Gap between position indicator and vibration damper A = 0.2 ... 2.0 mm (0.008 ... 0.08 in).

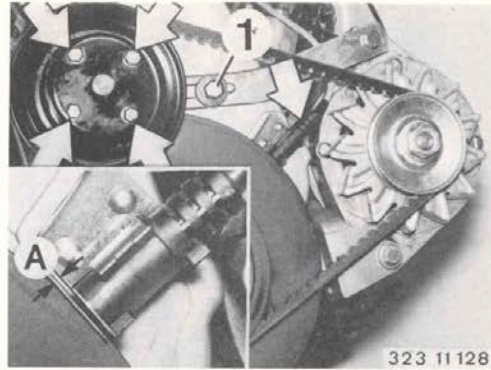

Detach vibration damper from hub.

When installing: centering pin (2) must be in hole on vibration damper.

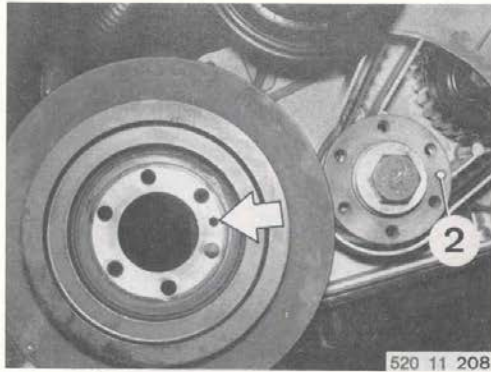

Prevent hub from turning with retainer 11 2 150.

Unscrew bolt (3)¹⁾.

Take off shouldered disc (4).

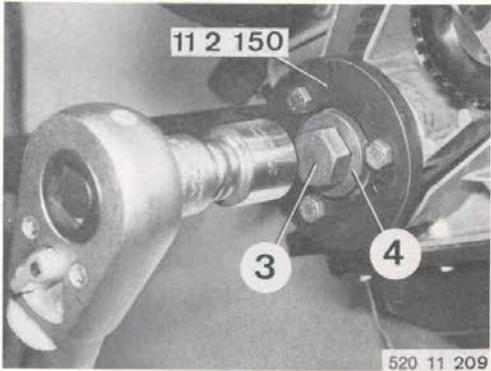

Insert bolt (3) by approx. 3 turns.

Pull off hub with Kukko puller 00 7 501 and threaded spindles 11 2 132 from crankshaft.

Remove bolt (3).

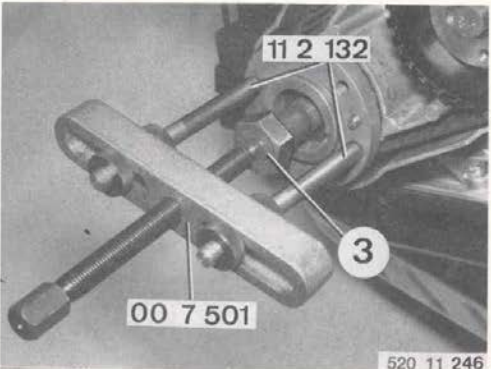

¹⁾ For correct tightening torque, see Specifications.

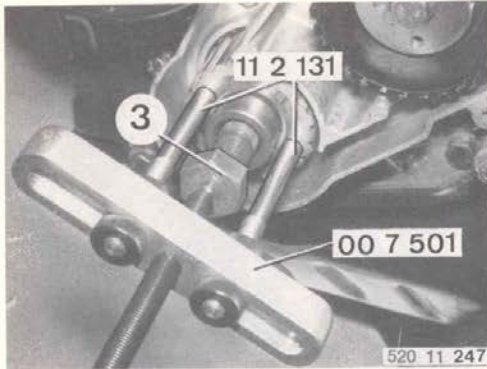

Take off the toothed belt – 11 31 110.
 Insert bolt (3) again.
 Detach sprocket from crankshaft with Kukko puller 00 7 501 used in conjunction with threaded spindle 11 2 131.
Important: note shaft key.
When installing: mount the sprocket with the tapped holes facing out.

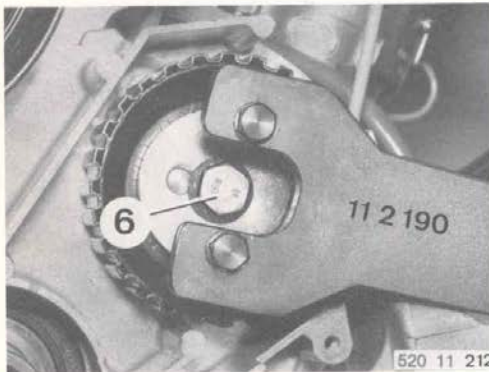

Use special tool 11 2 190 to prevent the intermediate shaft sprocket from turning.
 Remove bolt (6)¹⁾.
 Take off the washer and the sprocket.

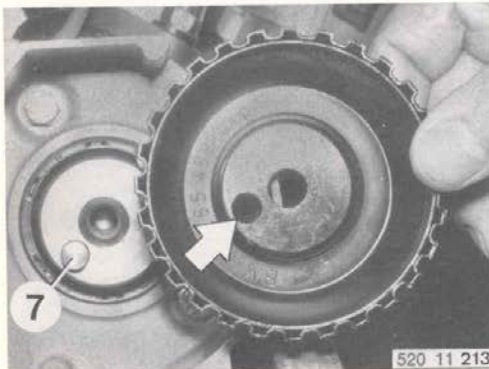

When installing: the centering pin (7) must enter the hole on the intermediate shaft.

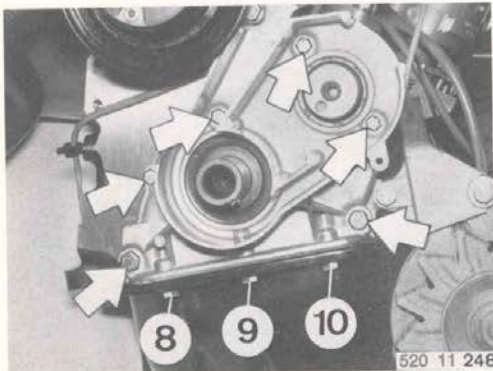

Remove bolts (8 ... 10).
 The remaining oil sump bolts should only be slacked.
 Take off the cover.
When installing: use a new gasket.
 If the oil sump gasket becomes damaged, detach the sump and renew the gasket – 11 13 000.

¹⁾ For tightening torque, see Specifications

Check condition of radial sealing rings and renew if necessary.

Warning: install only with sleeves 11 2 211 for crankshaft and 11 2 212 for intermediate shaft.

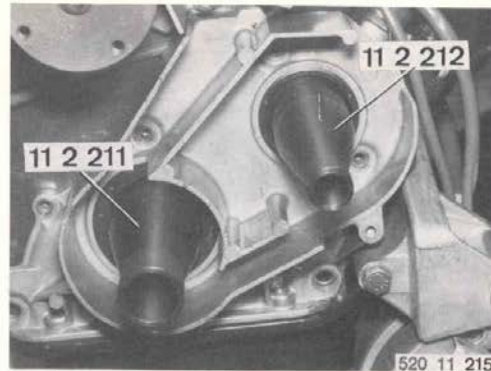

11 14 180 Radial sealing rings in end cover – renewing

Remove the end cover – 11 14 175.
Press the radial sealing rings out of the cover.
Drive in radial sealing rings with sleeve 24 1 050 for crankshaft or drift 33 1 180 and handle 00 5 500 for intermediate shaft.
Sealing rings must be driven in until flush.
Pack sealing lips with grease.

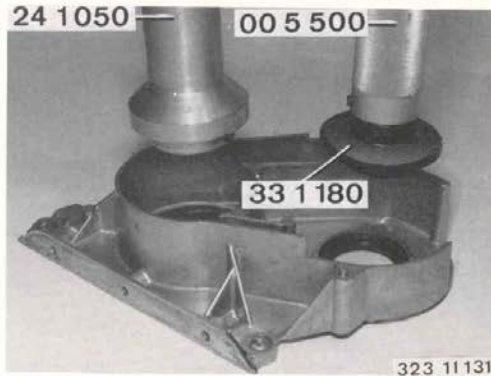

11 14 611 Radial sealing ring in clutch end cover – renewing – flywheel removed –

Remove the bolts at the oil sump – end cover.
Only slacken the remaining oil sump bolts.
Detach the end cover.
If the oil sump gasket is damaged, detach the oil sump – 11 13 000.

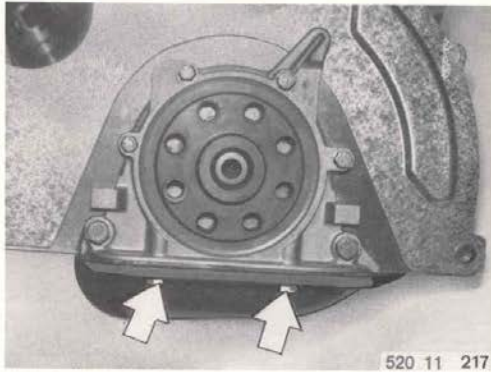

Renew gasket (1).

Warning: check that the sealing cover (2) for the main oil passage is not leaking, and renew sealing plug (3) if necessary.

Apply Loctite No.270 to sealing plug before inserting.

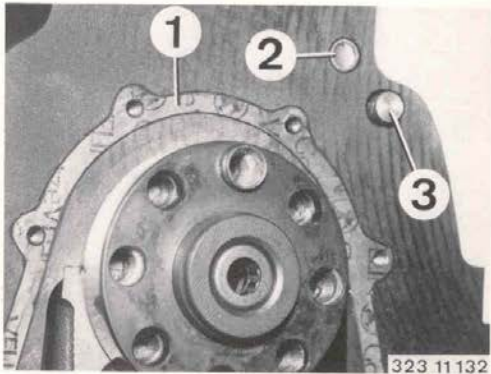

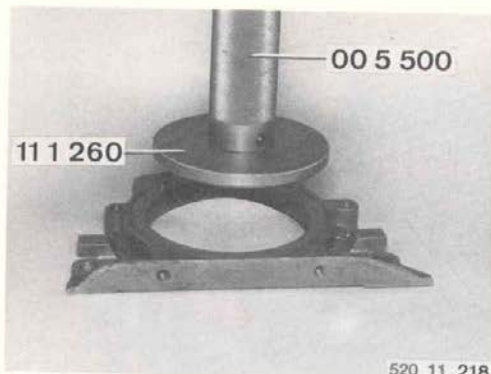

Press in the radial sealing ring with driving sleeve 11 1 260 in conjunction with handle 00 5 500.
Pack the sealing lips with grease.

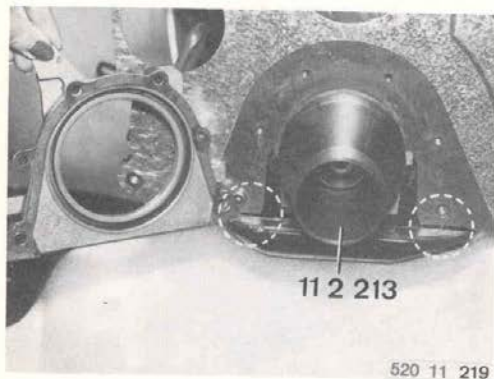

Coat the joint line between the end cover and oil sump with 'Atmosit' or 'Curil K 2'.
To prevent damage to the radial sealing ring, use slipover bushing 11 2 213.

11-14/4

11 21 000 Crankshaft – removing and installing

Remove engine – 11 00 050.
Secure crankcase to assembly stand 00 1 500 with assembly plate 11 0 120.

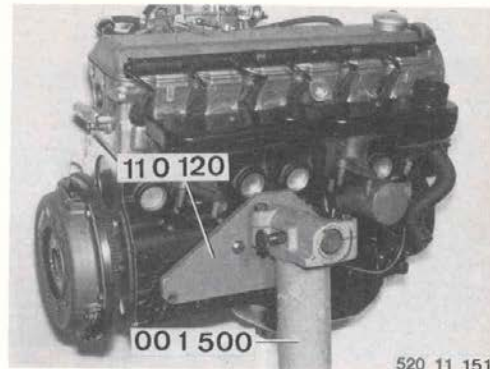

Detach the clutch – 21 21 000.
Detach the cylinder head – 11 12 100.
Remove the front end cover – 11 14 175.
Detach the oil pump – 11 41 000.
Before removing the crankshaft, determine its endplay (axial play)¹⁾.
If maximum endplay is exceeded, check the locating bearing.

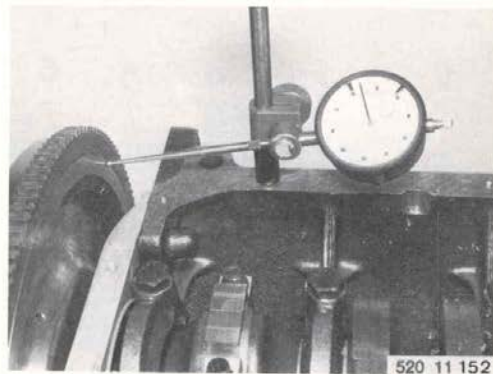

Remove the flywheel – 11 22 000.
Detach the end cover.
When installing: Apply a coat of 'Atmosit' or 'Curil K 2' to the joint line where the end cover meets the oil sump.

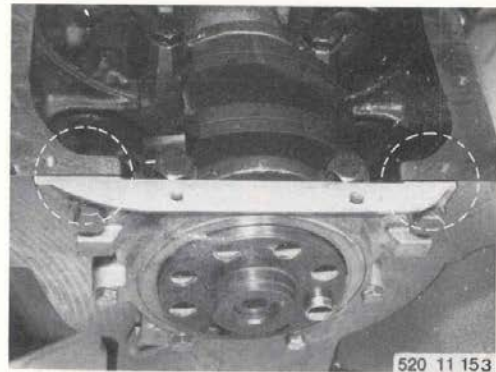

Install the big end bearing caps in the bottom dead center position.
When installing: the connecting rod and bearing cap for each cylinder are marked. Connecting rod 1 is at the toothed belt end. The cylinder reference numbers must all be on the same side.

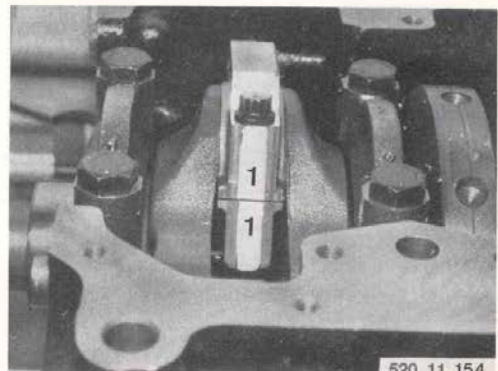

¹⁾ See specifications

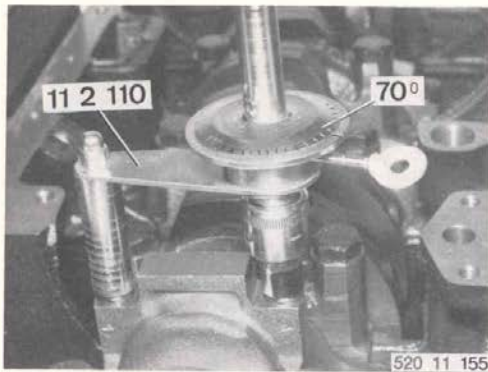

Note when installing: do not re-use old big end bolts. Tighten the bolts to the specified torque¹⁾. After this, turn the bolts through a further 70° with special tool 11 2 110.

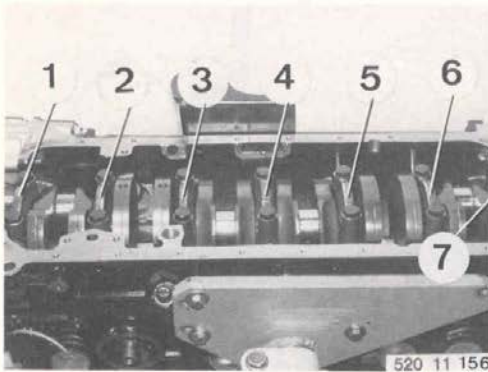

Take off the main bearing caps.
Lift out the crankshaft.

When installing: do not accidentally confuse the bearing caps.

Bearing cap 1 is at the toothed belt end.

Bearing cap 6 is the locating bearing.

If the crankcase has a different color code from the crankshaft, use one red and one blue bearing shell for each bearing journal.

Make sure that all blue or all red bearing shells are either at the top or the bottom.

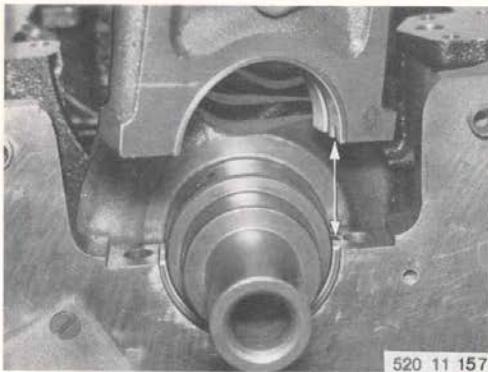

When installing: the grooves in the main bearing caps must coincide.

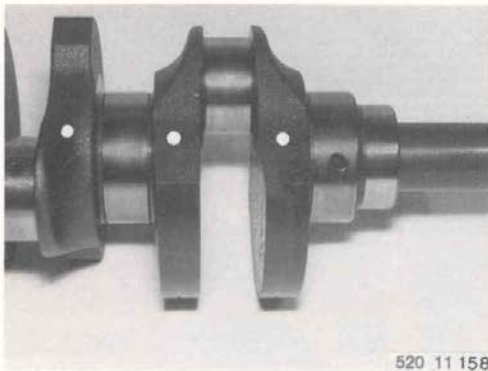

11 21 501 Crankshaft – renewing – crankshaft removed –

Transfer the needle roller race to the new crankshaft – 11 21 571.

Crankshaft identification:

Standard grinding dimensions: one red or blue paint spot at side of counterweights.

¹⁾ See specifications

Reground crankshafts are marked with paint stripes.

Big end bearing journal (A)

- 1 paint stripe: undersize 1¹⁾
- 2 paint stripes: undersize 2¹⁾

Main bearing journal (B)

- 1 paint stripe: undersize 1¹⁾
- 2 paint stripes: undersize 2¹⁾

Warning: the crankshaft is 'Tenifer' treated and can only be reground at the factory.

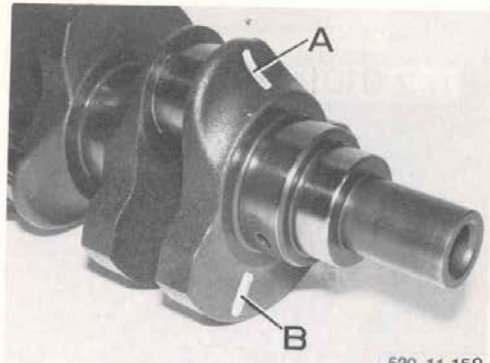

Install the correct bearing shells to suit the bearing journal diameters now in use; the same red or blue color codes must appear on the bearing shells as on the crankshaft.

If the crankcase has a different color coding from the crankshaft, use one red and one blue bearing shell per bearing journal.

Red and blue bearing shells are supplied with replacement crankshafts.

When installing: make sure that either all blue or all red bearing shells are installed at the top or at the bottom.

1 Main bearing shell

2 Locating bearing shell

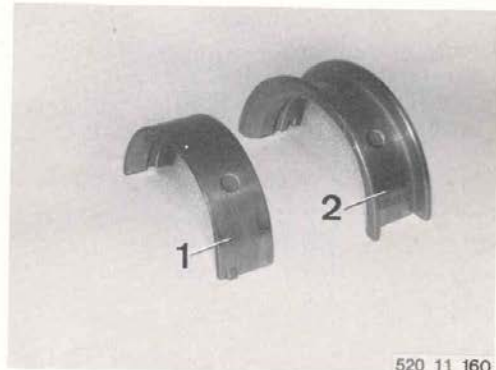

Check bearing play¹⁾ with 'Plastigage' Type PG 1.

- Measure each bearing separately.
- Bearing surfaces must be oil-dry.
- Measure with crankshaft at top dead center.
- Tighten bearing cap to specified torque¹⁾.
- Do not turn the crankshaft during the measuring procedure.
- Read off bearing play¹⁾ by comparing the width of the compressed area of plastic strip with the scale.

'Plastigage' is supplied in three different diameters.

'Plastigage' supplier:

ERN Co., Schinkelstr. 46-48, 4000 Düsseldorf.

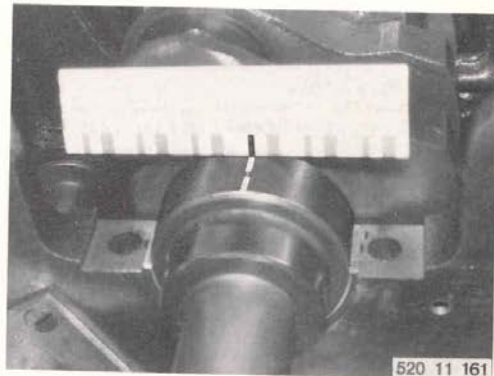

1) See specifications

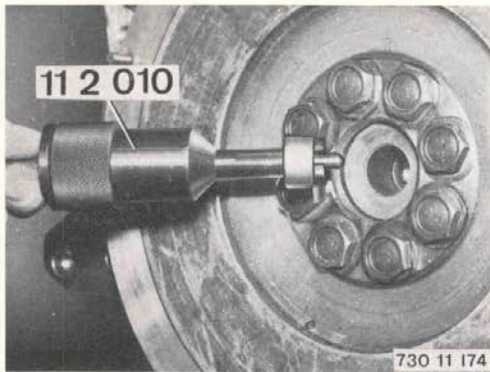

**11 21 571 Needle roller race in crankshaft
– renewing – clutch removed –**

**Remove needle roller bearing from crankshaft
with puller 11 2 010.**

When installing: Inscription on needle roller
bearing should face out.

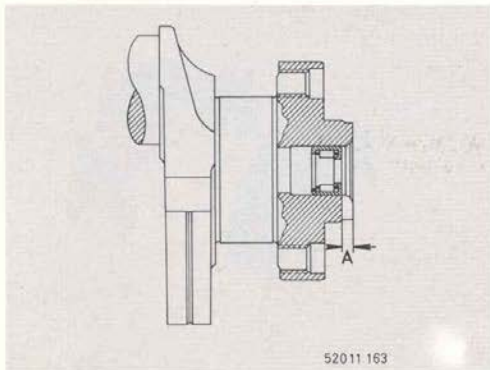

**Drive in the needle roller race with a suitable
arbor.**

Keep to dimension A = 5 mm (0.2 in).

**Pack the needle roller race with a brand-name
multipurpose grease.**

11 22 000 Flywheel – removing and installing

Remove the clutch – 21 21 000.
Check the flywheel for axial runout¹⁾.

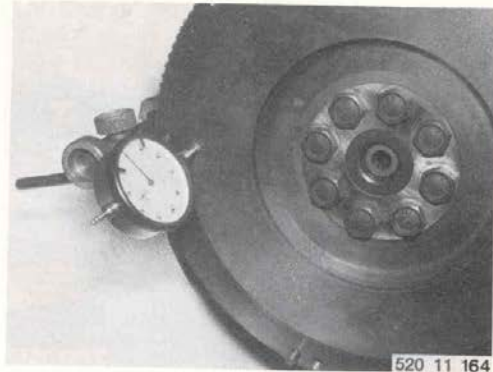

Prevent the flywheel from turning with holder 11 2 170.

Remove the expansion bolts.

Important: when installing, use new expansion bolts and apply Loctite No.270 to them before inserting.

Take off the flywheel.

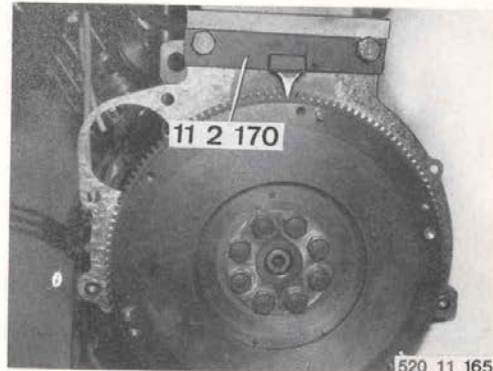

When installing: the clutch friction surface may be skimmed if not flat¹⁾.

However, the wall thickness within the rubbed area must not drop below 13.5 mm (0.531 in) – A.

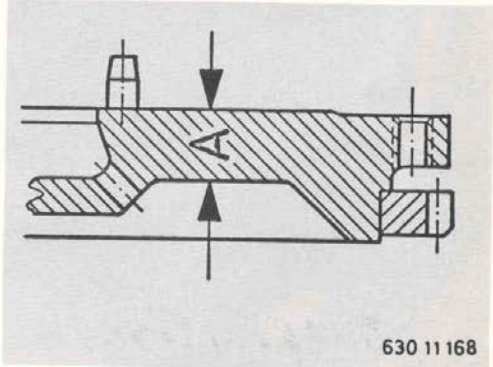

11 22 051 Torque converter driving plate – renewing

Remove the transmission – 24 00 020.
Prevent the flywheel from turning with holder 11 2 170.

Remove the expansion bolts.

Important: when installing, use new expansion bolts and apply Loctite No.270 to them before inserting.

Renew the driving plate.

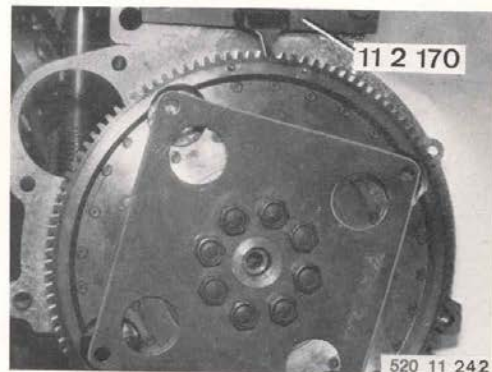

¹⁾ See specifications

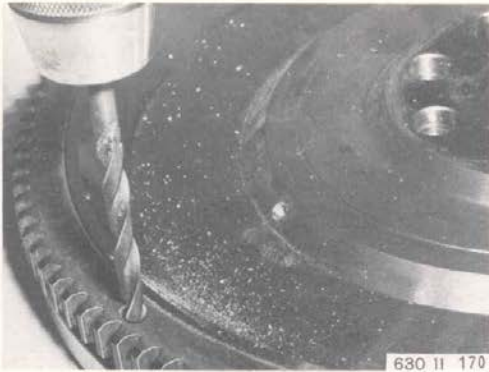

11 22 541 Starter gear ring – renewing

To simplify removal of the gear ring, drill into it below a tooth gap for a depth of app. 8 mm (0.31 in) with a 6 mm bit.

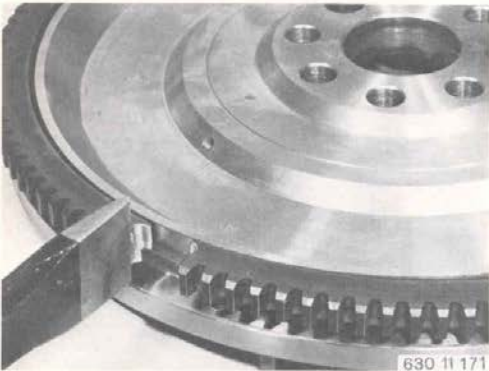

Split the gear ring by striking with a cold chisel in the tooth gap above the drilled hole.

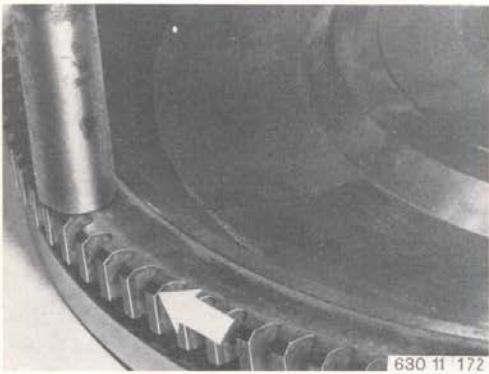

When installing: heat the new starter gear ring to 200 ... 230°C (392 ... 445°F), using a thermo-chrome pin. The chamfered side of the gear teeth faces the engine. Drive the gear ring fully home with a brass drift.

11 24 521 All connecting rods – renewing – pistons detached –

Warning: the connecting rods in any engine must all be of the same weight group, with a total weight tolerance of ± 4 g (0.141 oz) without the bearing shells.

The weight group is shown by a color code. If no color code is visible, a second connecting rod must be removed and the weights compared.

Warning: connecting rods must not be refaced:

The piston pin¹⁾ should slide through the small-end bearing bushing when only light pressure is applied.

Check connecting rod for deviation from parallel (A) and permissible maximum twist (B), and re-align if necessary.

A 150 -0.04 mm (5.9055 -0.0016 in)

B $0^\circ -30'$

Install big end bearing shells in connecting rod.

Place 'Plastigage PG 1' on oil-free big end bearing journal.

Attach connection rod to crankshaft.

Note identification marks used to match connecting rod and big end bearing cap.

¹⁾ For piston pin running clearance, see Specifications.

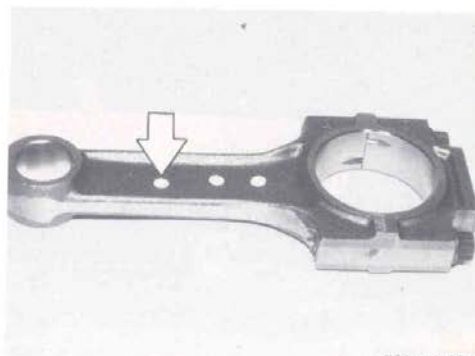

520 11 166

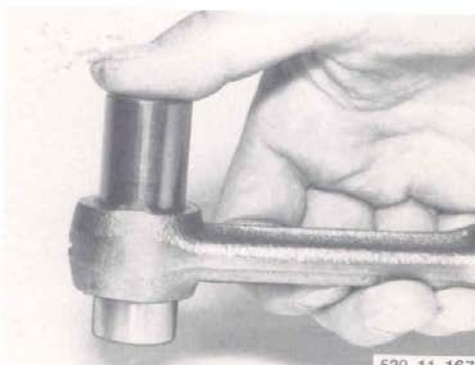

520 11 167

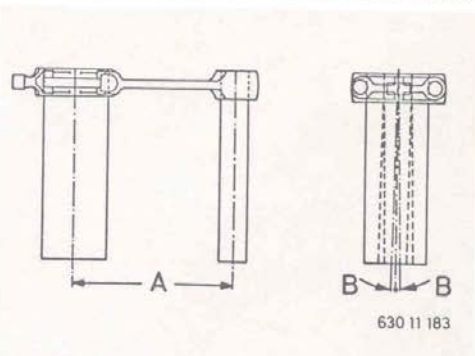

630 11 183

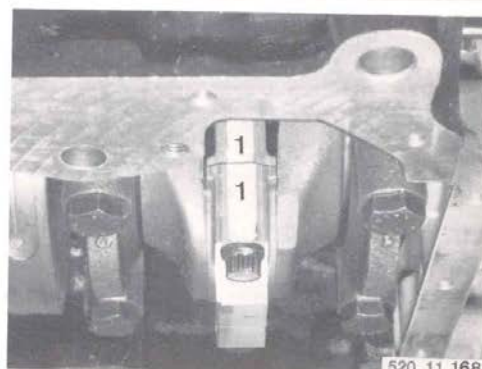

520 11 168

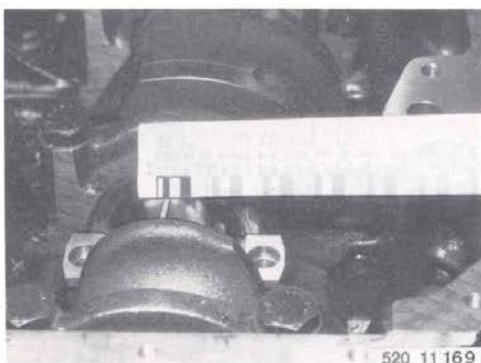

To measure bearing play, use old big end bearing bolts.

Tighten the bearing cap to the specified torque¹⁾.

Warning: do not twist the connecting rod or the crankshaft.

Take off the bearing cap.

Compare the width of the compressed plastic strip with the calibrated scale to establish bearing play¹⁾.

'Plastigage' supplier:

ERN Company, Schinkelstr. 46-48, 4000 Düsseldorf, Federal Republic of Germany.

¹⁾ See specifications

11 25 000 All pistons – removing and installing

Detach cylinder head – 11 12 100.

Remove oil pump – 11 41 000.

Detach big end bearing caps in bottom dead center position.

When installing: the connecting rod and bearing cap for each cylinder are marked. Connecting rod 1 is at the toothed belt end. The cylinder reference numbers must always be on the same side when installed.

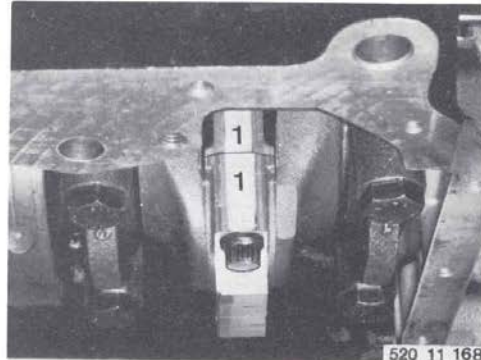

Important: use new big end bolts when installing.

Tighten bolts to specified torque¹⁾. After this, tighten bolts by a further 70° with special tool 11 2 110.

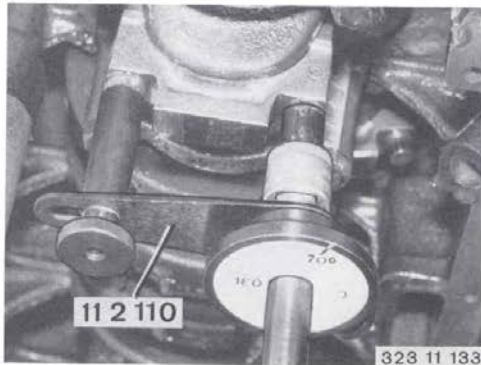

Press the piston and connecting rod out upwards.

When installing: stagger the piston ring gaps by 120°.

The arrow on the piston crown must face the toothed belt.

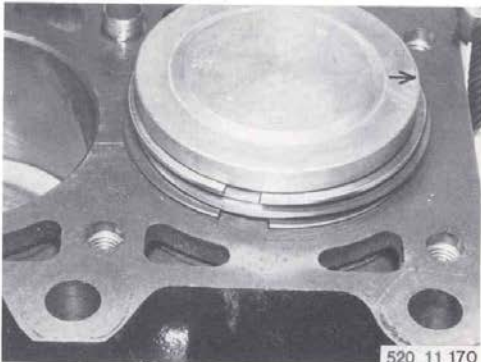

Mark the correct relative positions of connecting rod and piston.

Extract snap ring (1).

Remove piston pin.

When installing: piston pin and piston are matched and must not be interchanged.

Warning: install only pistons of the same make and weight group in the engine.

The weight group is indicated by a + or – stamped on the piston crown.

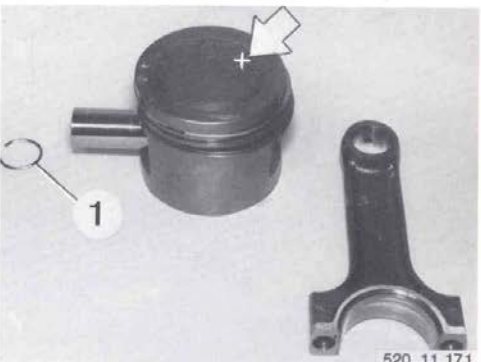

¹⁾ See specifications



Distinguishing features of pistons:

| BMW model | Piston diameter | Piston crown H = | Identification mark on piston crown |
|-----------|---------------------|----------------------|-------------------------------------|
| 320 | 80 mm (3.150 in) | 2.1 mm (0.827 in) | 2.0/9.2 |
| 323 i | 80 mm (3.150 in) | flat | 2.3/9.5 |

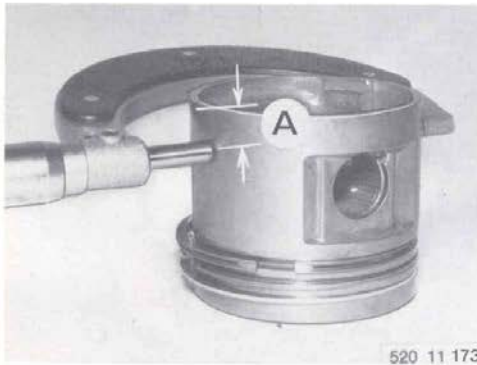

Check piston installed clearance¹⁾.

| BMW model | Piston make | Measuring point A = |
|-----------|-------------|---------------------|
| 320 | Mahle | 9 mm (0.354 in) |
| | KS | 25.95 mm (1.022 in) |
| 323 i | Mahle | 12 mm (0.472 in) |
| | KS | 28.05 mm (1.104 in) |

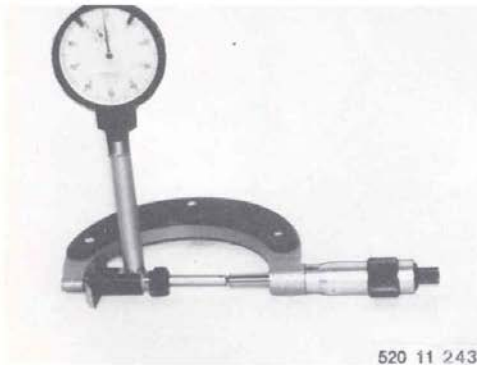

Set internal dial gauge to zero with the micrometer at the measured piston diameter.

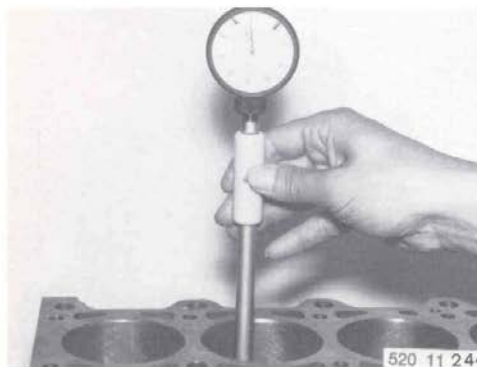

Measure the cylinder bore at 3 points across the center with the internal dial gauge. Determine piston installed clearance¹⁾.

¹⁾ See specifications

11 25 651 Piston rings for one piston – re-
newing – piston removed –

Measure clearance¹⁾ at ring flanks.



520 11 174

Remove piston rings and measure end gap¹⁾.

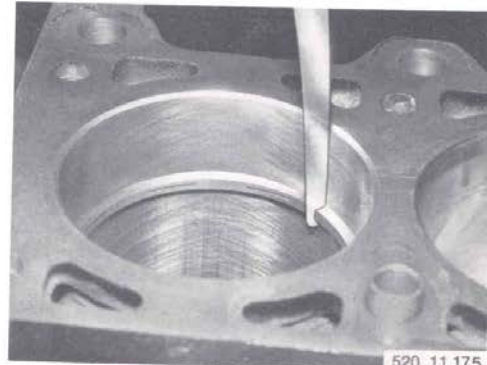

520 11 175

When installing: 'TOP' marking must be
nearest piston crown when piston ring is in-
stalled.

- 1 Rectangular-section ring
- 2 Micro-chamfer ring
- 3 Slotted oil-control ring with tubular spring



323 11 152

¹⁾ See specifications

11 31 000 Camshaft – removing and installing

Remove rocker shafts – 11 33 020.

Take off locating cover.

When installing: check condition of radial sealing ring (1) and cord ring seal (2), and renew if necessary.

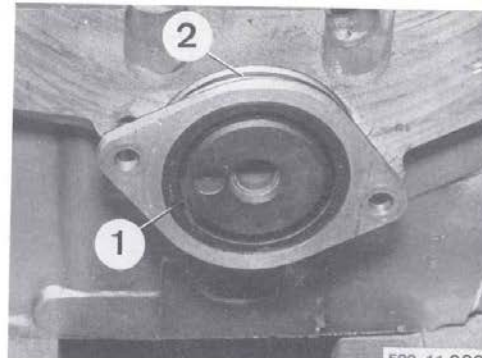

520 11 220

When installing: use bushing 11 2 212 to install locating cover.



520 11 221

Pull out the camshaft.

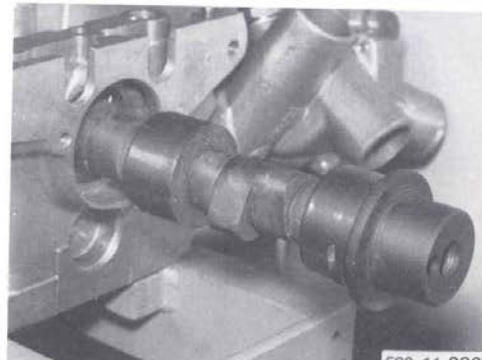

520 11 222

11 31 100 Toothead belt – tensioning

Unscrew bolts (1) to (3).

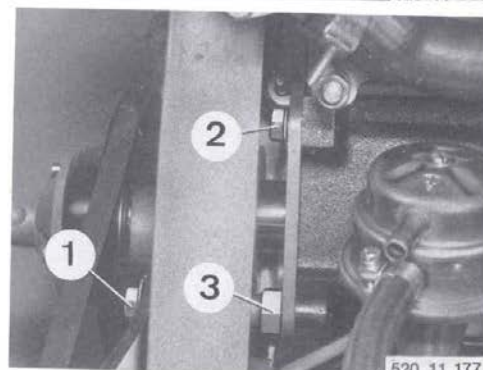

520 11 177

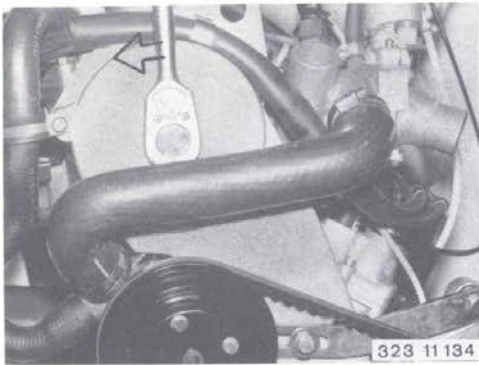

Warning: do not turn the engine over at the adapter unless the spark plugs have been removed.

Using a $\frac{1}{2}$ " ratchet, turn the engine through 1... 2 turns at the adapter, in the opposite direction to normal rotation.

This will tension the toothed belt.

In this position, retighten bolts (2, 3 and 1).

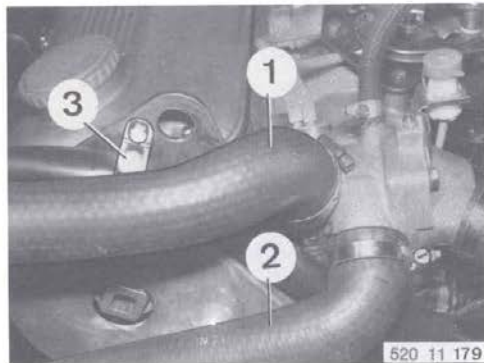

11 31 110 Toothed belt – removing and installing

Drain the cooling system.

When installing: bleed the cooling system – 17 00 039.

Detach the hot water hoses (1 and 2).

Detach holder (3).

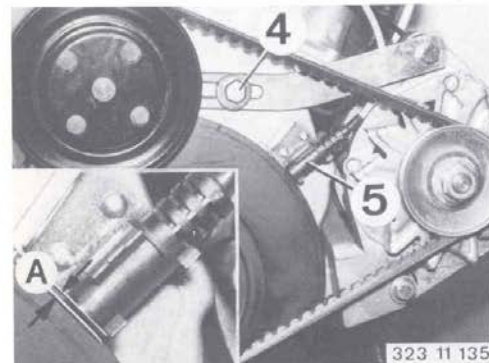

Take out bolt (4).

Take off the belt pulley.

Take off the V-belt.

When installing: adjust V-belt to correct tension.

It should be possible to depress the V-belt by 5... 10 mm (0.2... 0.4 in) at the center of its run. Lift position indicator (5) out of its clip.

When installing: make sure that the position indicator is correctly located. Gap between position indicator and vibration damper A = 0.2... 2.0 mm (0.008... 0.08 in).

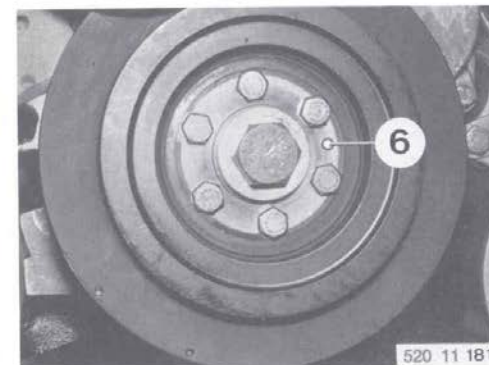

Detach the vibration damper from its hub.

When installing: centering pin (6) must locate in the hole on the vibration damper.

Detach protective cover.

When installing: do not forget to attach lug plate (2).

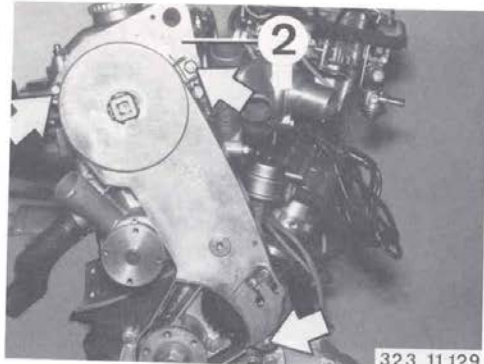

Warning: the engine must only be turned over at the adapter after the spark plugs have been removed.

Set the piston in cylinder 1 to top dead center. The arrow on the camshaft sprocket must be aligned with the mark on the cylinder head; the mark on the crankshaft hub must be aligned with the mark on the end cover.

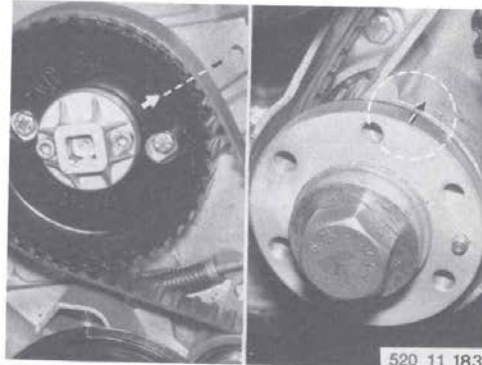

Mark the running direction of the toothed belt. Remove bolts (8) and (9).

Press the tensioning pulley inwards. Tighten bolt (8) in this position. Take off the toothed belt.

Warning: the engine must not be turned over at all when the toothed belt has been removed.

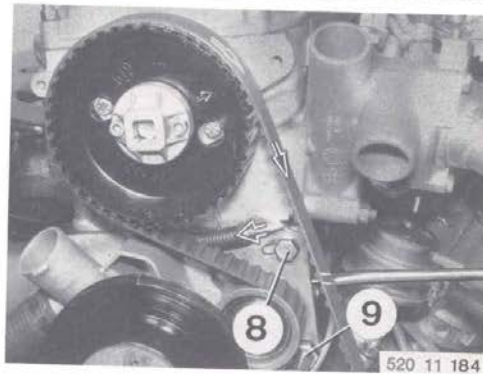

When installing: before placing the toothed belt on its sprockets, check the setting at the distributor housing. Take off the distributor cap.

The notch in the distributor housing must be aligned with the center of the engine speed governor.



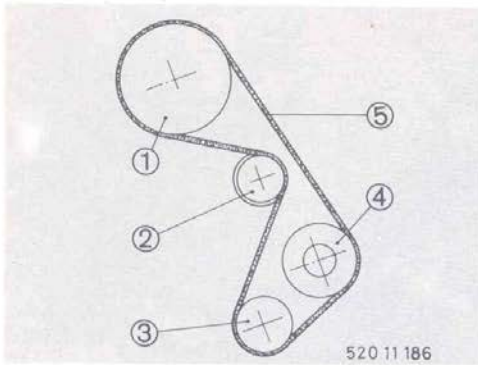

- Arrangement of toothed belt:**
- 1 Camshaft sprocket
 - 2 Tensioning pulley
 - 3 Crankshaft sprocket
 - 4 Intermediate shaft sprocket
 - 5 Toothed belt

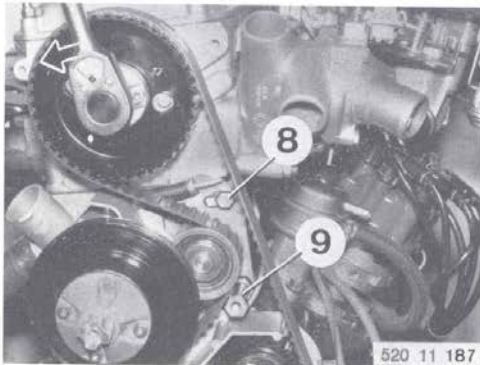

Examine the toothed belt for signs of damage, and renew if necessary.

Starting at the crankshaft sprocket and working in the opposite direction to engine rotation, place the toothed belt over all its sprockets. Release bolt (8) again.

Turn the engine by means of a $\frac{1}{2}$ inch ratchet head at the adapter for 1...2 turns in the opposite direction to normal rotation. This will tension the toothed belt correctly.

In this position, tighten bolts (8) and (9). Check the alignment of the crankshaft and camshaft marks again.

Retime the ignition – 12 11 004.

11 33 020 Rocker shafts – removing and installing

Remove cylinder head – 11 12 100.
Mount cylinder head on assembly fixture 11 1 060 and secure with one cylinder head bolt.
Detach oil line (1).
Take off the toothed belt.

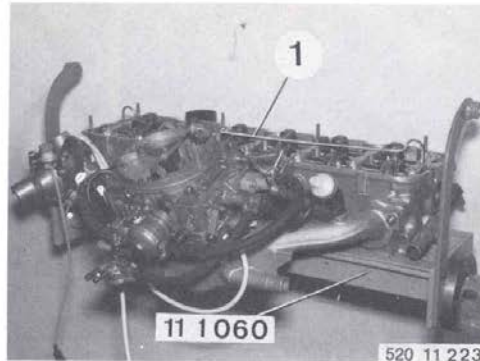

Set valve clearances for all cylinders to maximum.
Extract sealing plug.
Remove locating plate (2).
When installing: locating plate (2) must be in the grooves of the rocker shafts.

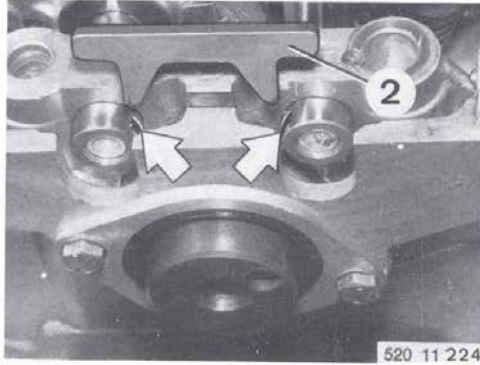

Remove the spring clips.
When installing: the straight face on the spring clip must be in the groove on the rocker shaft.

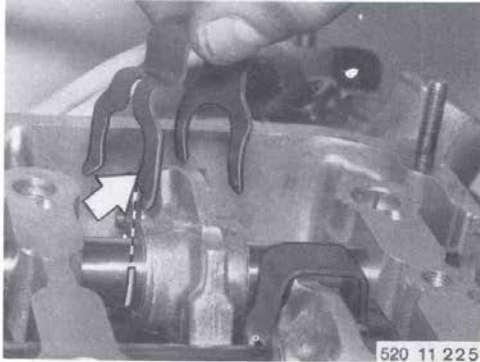

To turn the camshaft, attach washer (3) and adapter (4) to it.

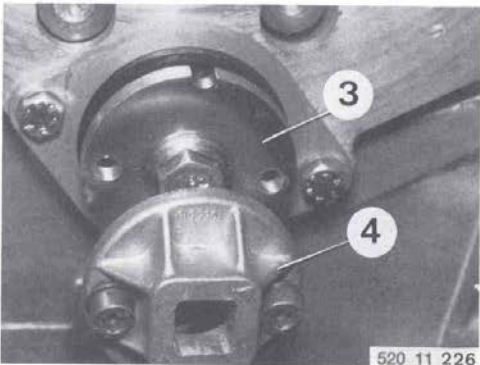

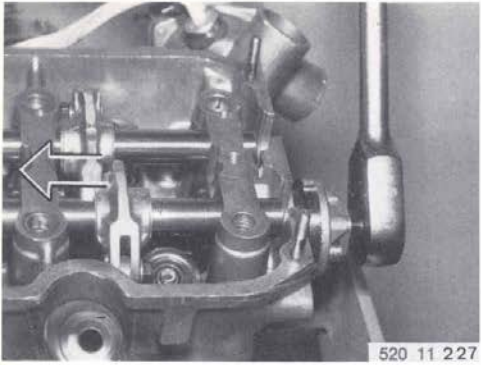

520 11 227

Remove the rocker shafts.

a) Exhaust side

Cylinder 6 must have the valves on overlap. Push the rocker for the first cylinder inwards. Turn the camshaft at the adapter towards the inlet side until all the rockers are no longer under spring pressure. Pull out the rocker shaft.

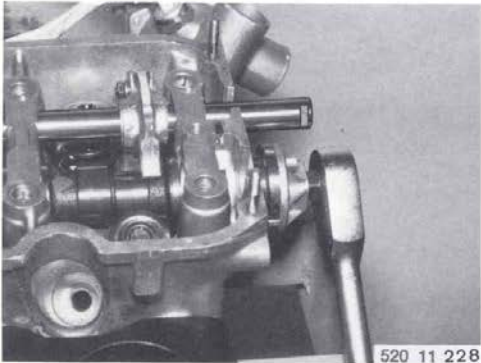

520 11 228

b) Inlet side

Turn the camshaft at the adapter towards the exhaust side until all rockers are relaxed. Pull out the rocker shaft. Renew rocker shafts and rockers if worn or scored.

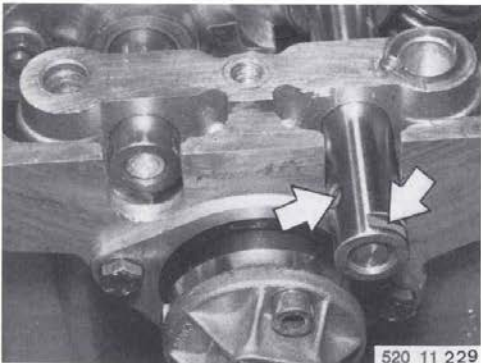

520 11 229

When installing: the large oil holes on the rocker shafts must face the valve guide and the grooves for the locating plate must face inwards.

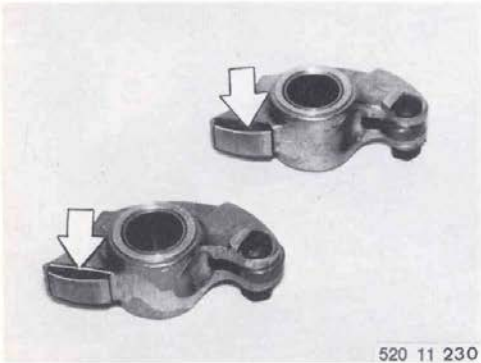

520 11 230

11 33 031 All rockers – renewing

Remove rocker shafts – 11 33 020. Renew rockers which are worn, scored or have loose pads. Loose pads will be audible in the form of excessive valve gear noise.

Transfer setscrew (1), eccentric (2), washer (3) and nut (4) to new rocker arm.

Replace worn eccentrics.

Important: Setscrew and nut have M 6 × 0.75 mm fine threads.

Hole faces outward and thick side downward. Bevelled side of setscrew faces tab on rocker arm.

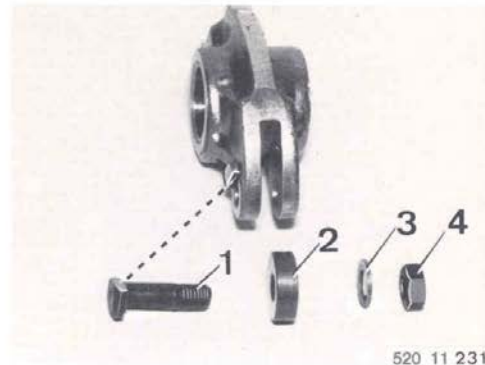

11-33/3

2.78

0000

000-0000

11 34 004 Valve clearances – adjusting

Remove cylinder head cover – 11 12 000.

Warning: engine must only be turned over at adaptor after removing spark plugs.

Turn engine with a $\frac{1}{2}$ " ratchet applied to adaptor.

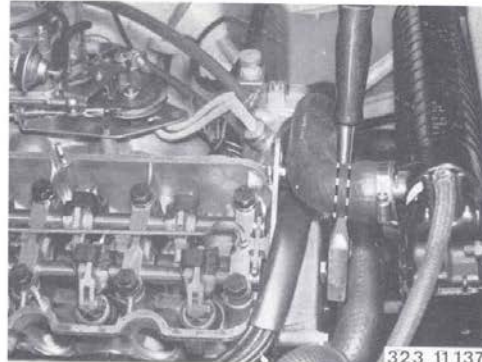

Adjusting sequence is same as firing order (1-5-3-6-2-4) at compression to dead center (TDC).

Adjust valve clearance¹⁾ between valve and eccentric after loosening nut (1).

Tighten nut (1) with special ring spanner 11 1 150 and torque wrench 00 2 050.

Note correct torque¹⁾.

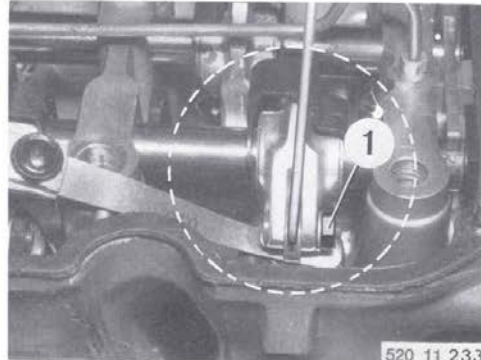

11 34 509 All valves – checking for leaks – camshaft removed –

Spark plugs remain installed.

Fill combustion chamber with gasoline.

Valves have to be machined when gasoline runs past valve head (see 11 12 607).

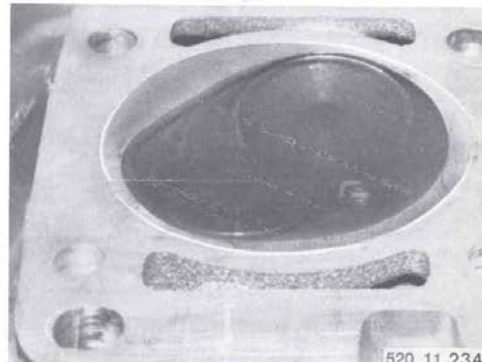

11 34 550 Valves – removing and installing – rocker shafts removed –

Place tray 11 1066 in assembly stand 11 1 060.

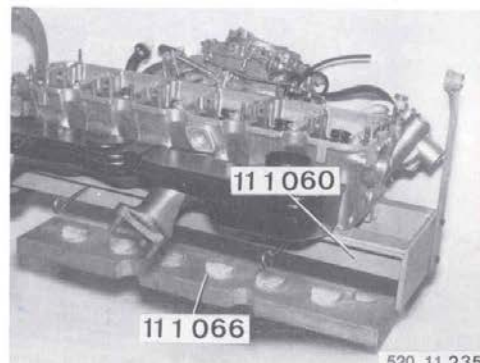

¹⁾ See specifications



Press down valve springs with special tool 11 1 060 and remove valve collets.

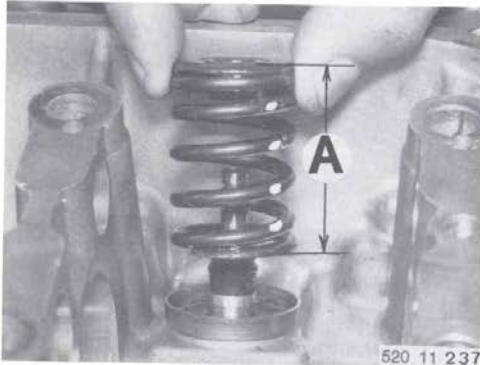

Remove upper spring retainer, spring and lower retainer.

When installing: Relaxed spring length A¹⁾.
Important: Valve spring is wound progressively.

End with tight winding (paint mark) faces cylinder head.

Pull out valve.

When installing: Lubricate valve guide and valve stem with oil.

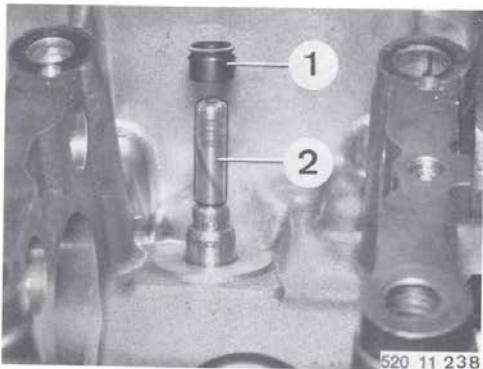

Pull off valve seal.

Replace valve seal (1).

Install valve.

Always use assembly sleeve (2) to prevent damage to valve seal.

Lubricate and install valve seal.

Supply source for assembly sleeves:

Cartool

Unterer Grasweg 88

D-8070 Ingolstadt

West Germany

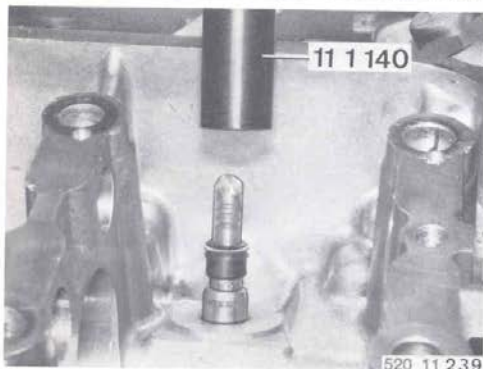

Press on valve seal with special tool 11 1 140 until a tight fit.

¹⁾ See specifications

**11 35 020 Distributor intermediate shaft –
removing and installing**

Remove front end cover – 11 14 175.
Detach guide plate (1).

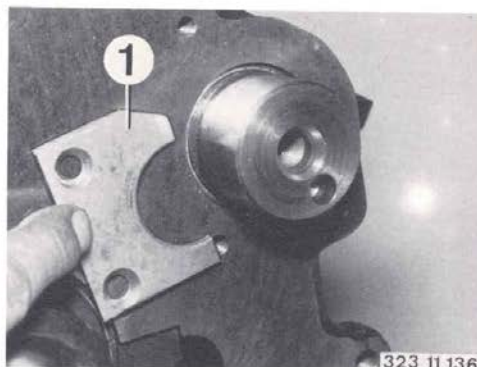

Pull out intermediate shaft (2).

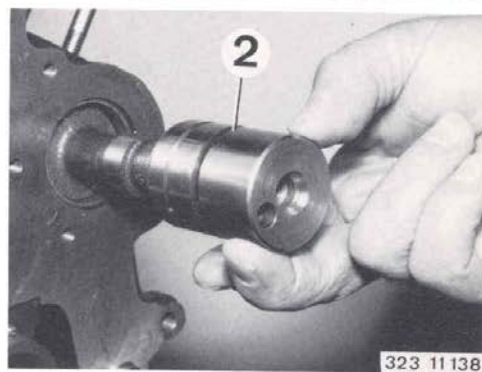

11 41 000 Oil pump – removing and installing

Remove oil sump – 11 13 000.
Take off oil pump.

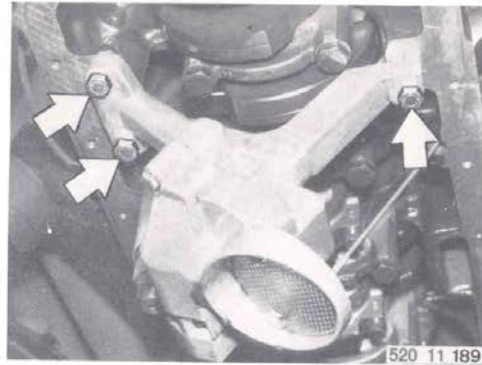

When installing: Guide input shaft (1) into distributor shaft.

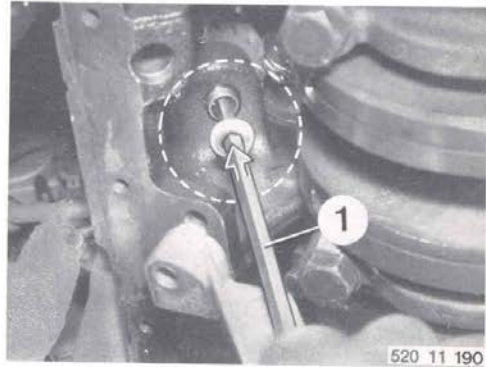

11 41 110 Pressure relief valve – removing and installing

Remove oil sump – 11 13 000.
Unscrew pressure relief valve.
Remove outer tube (1).

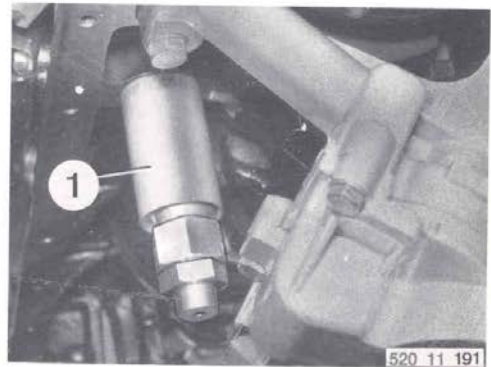

Unscrew plug (2).
Remove spring (3) and piston (4).
Important! Relaxed spring length¹⁾ must not be altered.

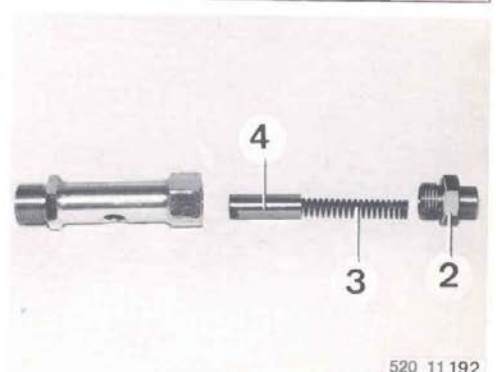

¹⁾ See specifications

11 51 000 Water pump – removing and installing

Drain coolant.

When installing: bleed cooling system – 17 00 039.

Detach belt pulley.

Unscrew bolt (1).

Take off V-belt.

When installing: Tension V-belt.

Take vibration damper off hub.

When installing: centering pin (2) must be in hole in vibration damper.

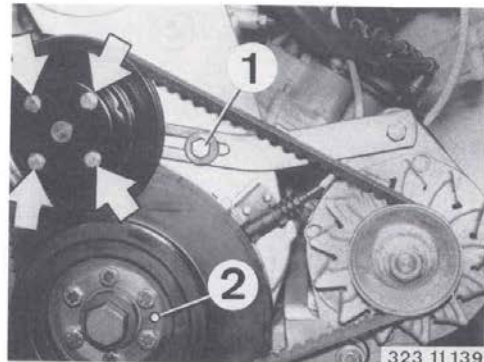

Loosen warm water hose (3), remove hose (4) and take off holder (5).

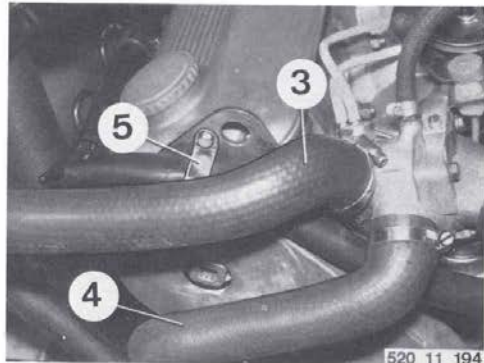

Remove position indicator (6) from mounting.

When installing: correct seating of position indicator. Gap between indicator and vibration damper must be 0.2... 2.0 mm (0.008... 0.08 in).

Remove cover.

When installing: Also attach suspension eye (7).

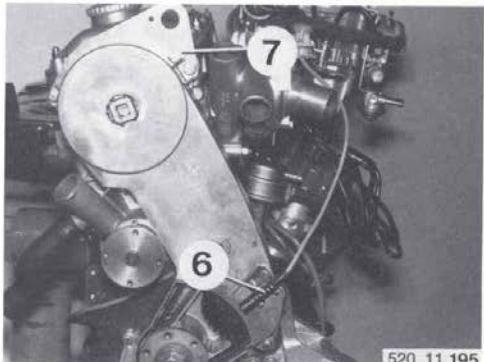

Hold clamping pin with special tool 11 5 010. Strong spring pressure!



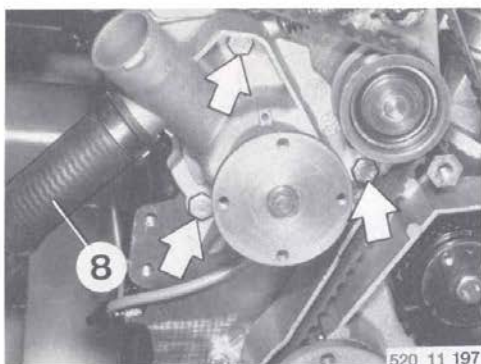

Loosen warm water hose (8).
Take off water pump.
When installing: use a new gasket.

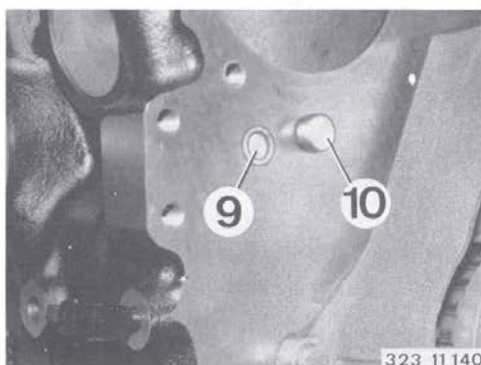

Important: check that end cover (9) of main oil passage is not leaking; install a new plug (10) if necessary.
Insert plug with Loctite Ref. No. 270.

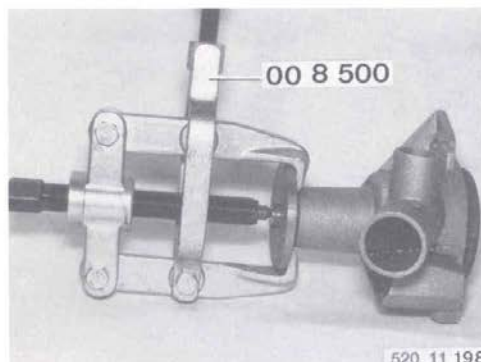

11 51 502 Water pump – stripping and assembling – water pump removed –
Pull off hub with special tool 00 8 500 (Kukko).

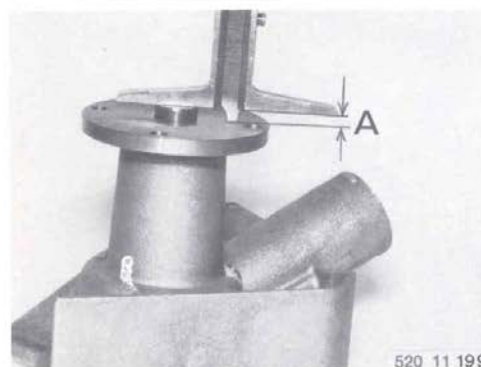

When installing: Distance A = 4.1 + 0.3 mm
(0.161 + 0.012 in).

Remove circlip (2).

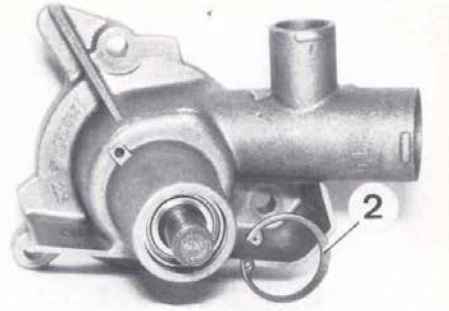

520 11 200

Press impeller off shaft and water pump bearing out of body.

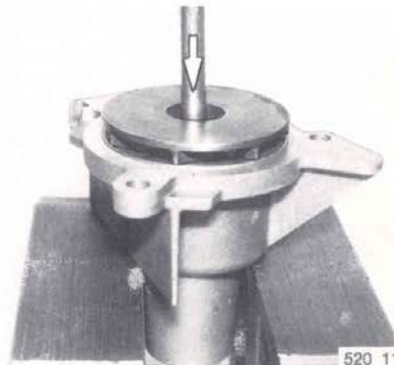

520 11 201

Renew bearing (3) and seal (4).
Check impeller (6) and renew if necessary.
When installing: Long shaft of bearing (3) faces impeller.

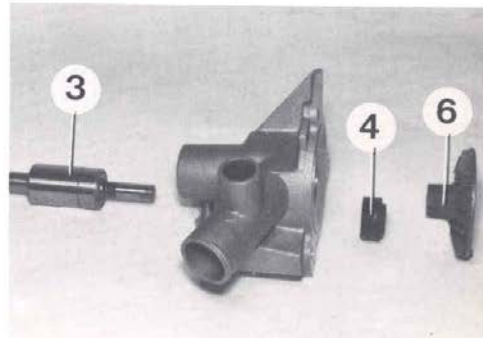

520 11 202

When installing: Press on impeller.
Distance **B** = 0.6 ± 0.2 mm (0.024 ± 0.008 in)
must be observed. Press-in force approx.
440 kp (970 lb); for new parts 500 kp (1100 lb).

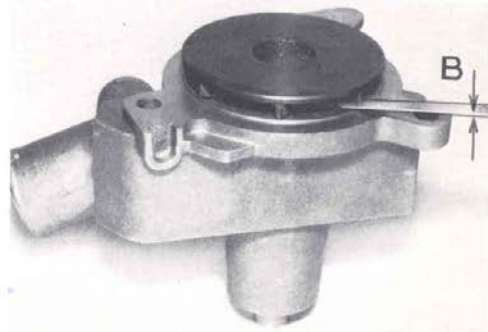

520 11 203

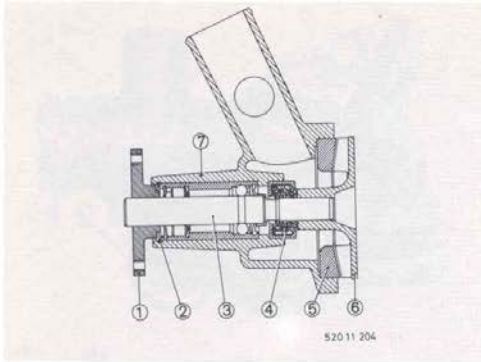

Water pump layout

- 1 Hub**
- 2 Circlip**
- 3 Pump bearing**
- 4 Seal**
- 5 Cover ring**
- 6 Impeller**
- 7 Body**

11 53 000 Coolant thermostat – removing and installing

Partially drain coolant.

When installing: bleed cooling system – 17 00 39.

Take off cover.

Remove thermostat.

Check beginning of thermostat opening¹⁾ in a hot water bath.

When installing: bracket on thermostat faces out.

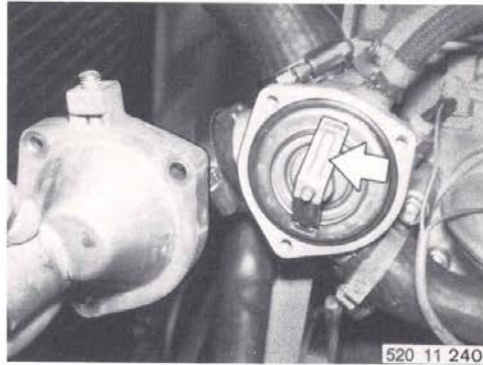

11 53 081 Temperature sensor – renewing

Disconnect wire from sensor.

Unscrew sensor.

Replace seal (1).

When installing: bleed cooling system – 17 00 039.

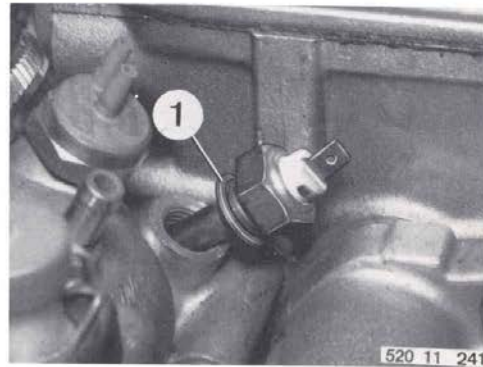

¹⁾ See specifications

11 61 000 Intake pipe and carburetor – removing and installing/sealing

Disconnect negative lead at battery.

Detach air cleaner – 13 71 000.

Drain coolant.

When installing: bleed cooling system – 17 00 039.

Detach supply (1) and return (2) fuel lines.

Detach preheating hose (3).

Disconnect cables (4) and (5).

When installing:

green/violet cable to control motor

green/black cable to cold-start housing

Detach carburetor controls.

Detach water hose (6).

Detach hoses (7) and (8) and remove by pulling down.

When installing: adjust accelerator cable – 35 41 421.

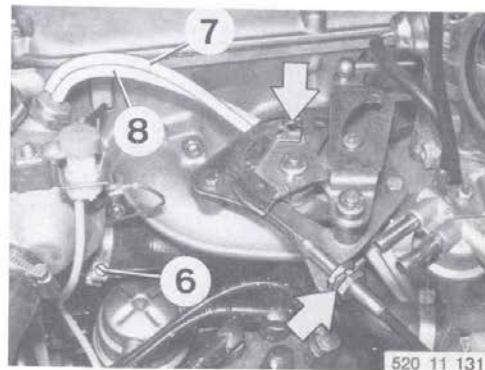
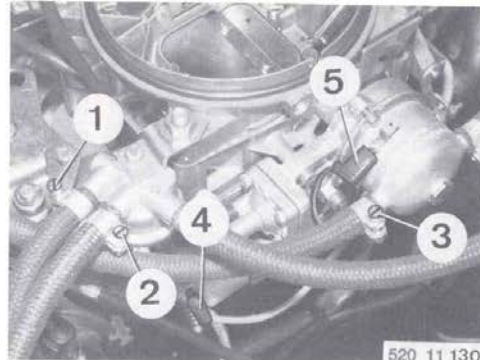

Detach black vacuum hose at distributor and wires at thermo switch.

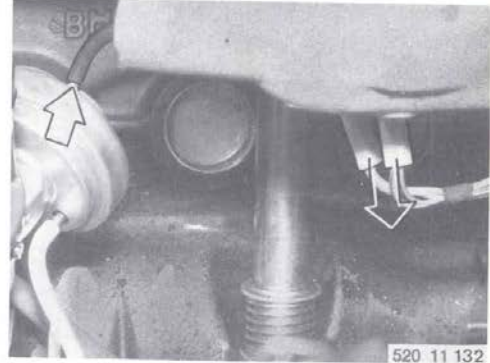

Pull off plug for idle cut-off valves.

Detach hoses (9 to 11).

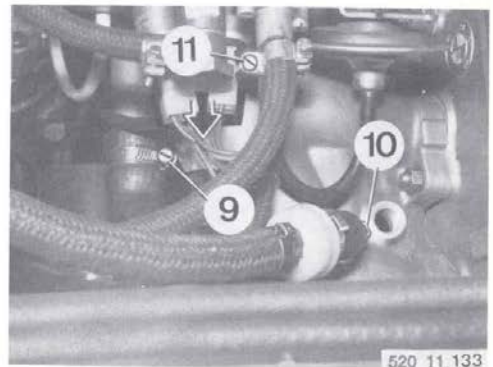

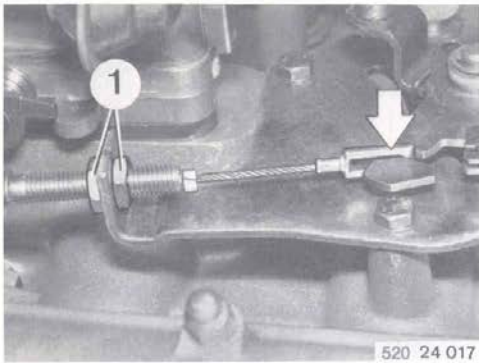

On automatic transmission cars:
Unscrew nuts (1).
Disconnect accelerator cable.
When installing: adjust accelerator cable (see 24 00 004).

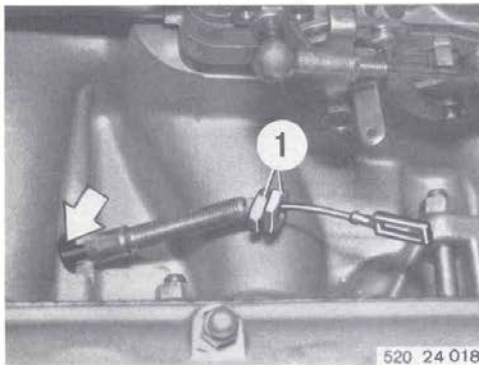

Unscrew nuts (1) and pull accelerator cable out downwards through hole in intake manifold.

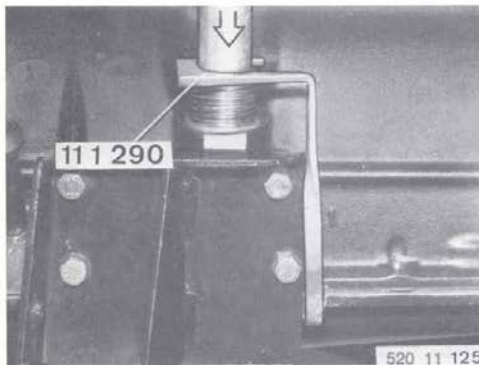

Press down balance tube and lock with special tool 11 1 290.

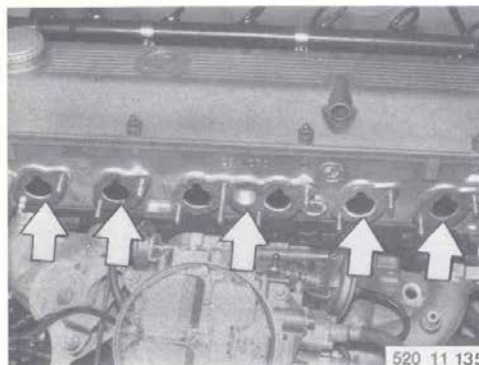

Detach intake manifold at cylinder head.
When installing: use new gaskets. Note installed position of gaskets.

11 61 050 Intake air collector – removing and installing

**Disconnect negative lead at battery.
Drain the cooling system.**

When installing: bleed the cooling system – 17 00 039.

Disconnect intake cowl.

Disconnect manifold (1).



323 11 141

Detach accelerator cable and remove from reaction bearing.

When installing: adjust accelerator cable – 35 41 421.

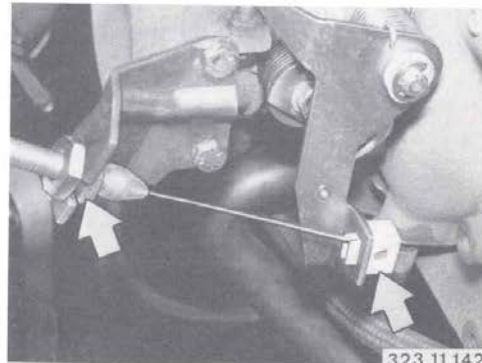

323 11 142

**Detach hoses (2 and 3).
Pull off vacuum hose (4).**



323 11 143

**Pull off vacuum hose (6).
Detach hose (7).
Detach hose (8) at branch flange.
Pull off plugs (9) and (10).
Detach fuel line (11).**

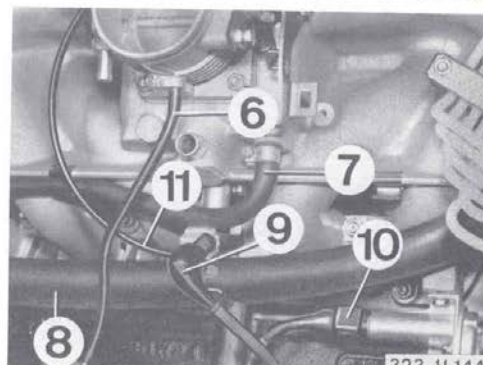

323 11 144

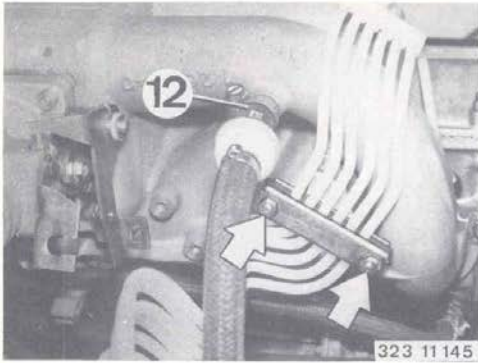

Take off vacuum hose (12).
Detach holder at air collector.

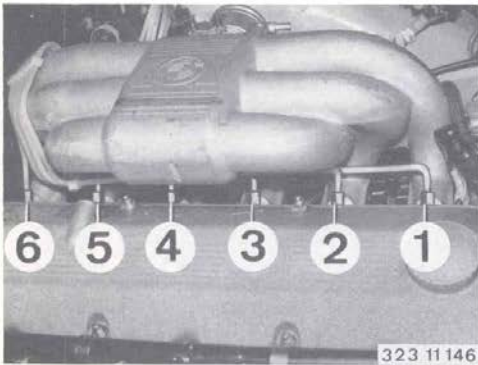

Detach injector pipes (1... 6).

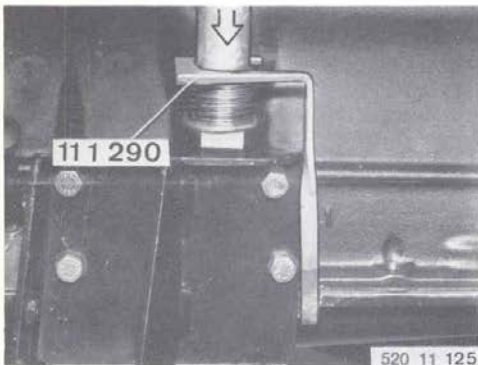

Press equalizing pipe down and hold with special tool 11 1 290.



Detach air collector from cylinder head.

When installing: renew gaskets and ensure they are correctly positioned.
Renew sealing ring (13).

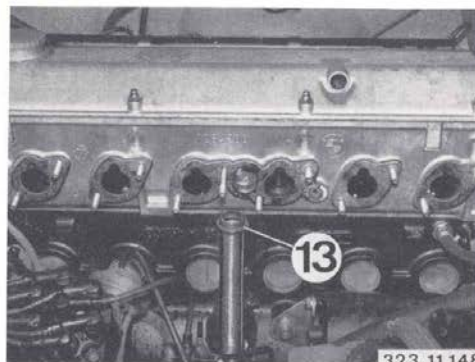

11 61 051 Intake air collector – renewing

Remove the air collector – 11 61 050.
Transfer the throttle butterfly stub pipe (1), cold-start valve (2), holder (3) and additional air slide (4) to the new air collector.

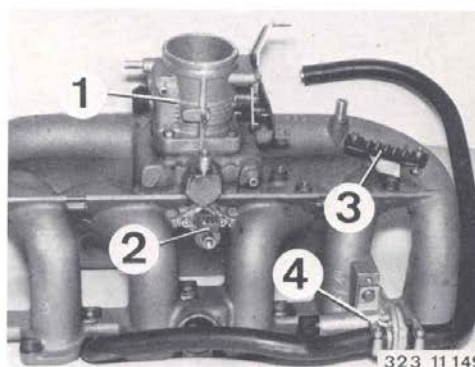

Transfer injectors 1... 6.
Renew sealing rings (5) and coat with Vaseline or similar before installing.

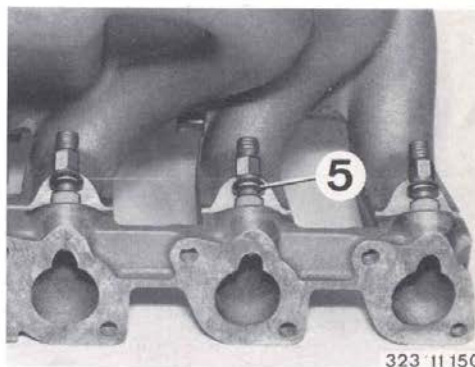

11 74 051 Thermo valve – renewing

Test: Detach hose (1) at thermo valve.
Detach hose (2) at distributor and blow through it.

Thermo valve must be closed at coolant temperatures up to $+13 \pm 3^{\circ}\text{C}$ ($55 \pm 6^{\circ}\text{F}$) and open from $+20 \pm 3^{\circ}\text{C}$ ($+68^{\circ} \pm 6^{\circ}\text{F}$).

Unscrew thermo valve.

Add coolant.

Important: Only install thermo valves with designation PE 20 286 yellow or 51 AB 12 blue with a yellow spot.

