

Ferrari

308



Workshop

Manual

Ferrari

MODEL

Dino 308GT4

WORKSHOP
MANUAL

This book is a reprint by MAR PARTS Ltd.
for reference by owners.

Original factory stocks exhausted.

Part No. 95990809

Batch No. MP2158



FERRARI-SERVIZIO ASSISTENZA TECNICA-Modena

SECTION INDEX	Section
GENERAL INFORMATION	A
ENGINE	B
LUBRICATION COOLING FUEL SYSTEM	C
CLUTCH GEARBOX REAR AXLE	D
STEERING	E
FRONT SUSPENSION	F
REAR SUSPENSION SHOCK ABSORBERS	G
BRAKES WHEELS AND TYRES	H
INSTRUMENTS AND CONTROLS HEATING AND VENTILATION AIR CONDITIONING	I
ELECTRIC SYSTEM	L
SPECIAL TOOLS (Engine-Chassis) TIGHTENING TORQUES CHASSIS HITCH POINTS	M
BODY	N
EMISSION CONTROL SYSTEM	O

SECTION **A**

GENERAL INFORMATION

	Page
MAIN SPECIFICATIONS	A 3
PERFORMANCES	A 4
REFUELLING	A 5
IDENTIFICATION PARTICULARS	A 6
SPARE PARTS	A 6

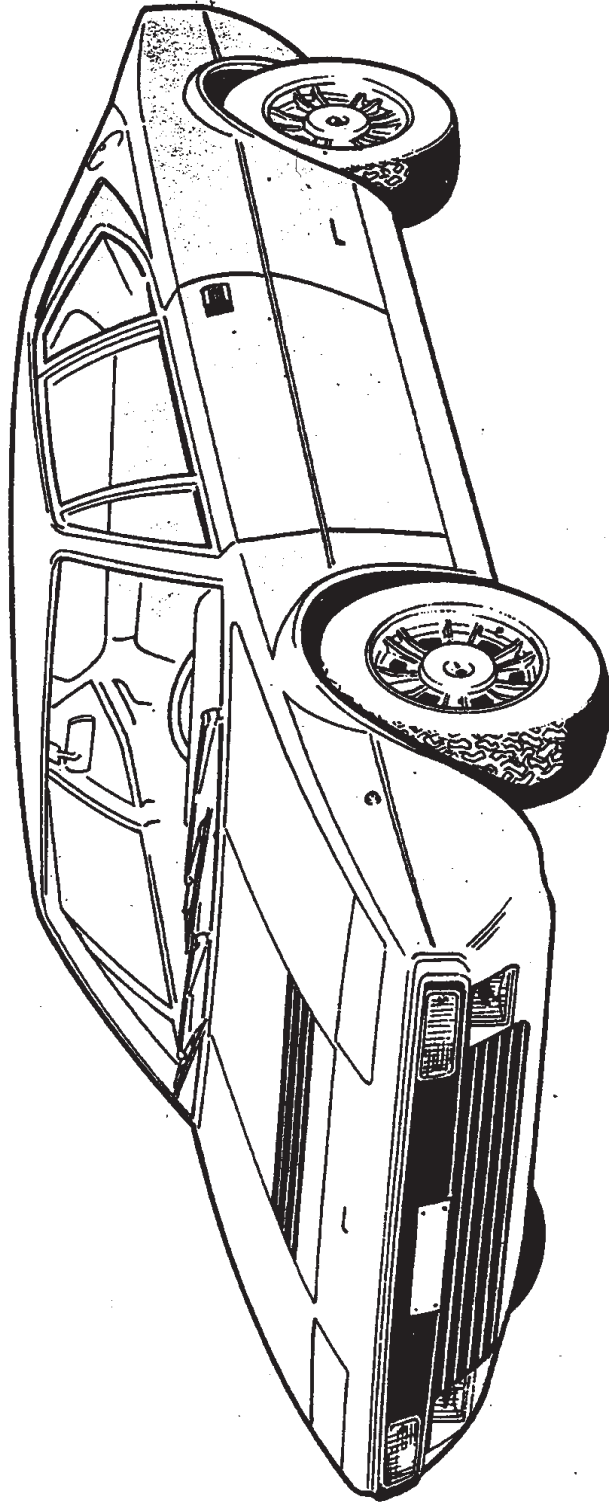

DINO 308 GT.4 MODEL

GENERAL INFORMATION

MAIN SPECIFICATIONS

IDENTIFICATION PARTICULARS

Chassis type F 106 AL
 Engine type F 106 A

ENGINE

Layout transversal in front
 of the rear axle
 Cylinders 8 V 90
 Bore mm. 81
 Stroke mm. 71
 Displacement cm³ 2926,9
 Compression ratio 8,8:1
 DIN maximum power CV 250
 Corresponding engine
 speed RPM 7000
 Maximum torque kgm. 29
 Corresponding engine
 speed RPM 5000
 Italian fiscal rating CV 33

CLUTCH

Dry single plate
 Diaphragm pressure plate
 Mechanical clutch control
 Spring assisted

GEARBOX

Five forward speeds and reverse
 Synchromesh rings on forward
 speeds.
 Gearshift lever on tunnel

REAR AXLE

Integral with the gearbox
 Displacement final reduction
 torque.
 Reduction ratio 17/63
 Limited slip differential
 Self locking 40%

STEERING

Rack and pinion type
 Steering wheel turns from lock
 to lock 3,28
 Minimum turning circle
 diameter m. 12

FRONT SUSPENSION

Independent wheels.
 Swinging arms with coil springs
 on hydraulic shock absorbers.
 Transversal anti-roll bar.

REAR SUSPENSION

Independent wheels.
 Swinging arms with coil springs
 on hydraulic shock absorbers.
 Transversal anti-roll bar.

BRAKES

Self-ventilating discs; hydraulically
 operated by pedal acting on
 the four wheels. Two pumps, two
 independent circuits.
 Vacuum servo-brake.
 Limiting braking valve on the re-
 ar brakes.

Hand brake:
 mechanically operated by control
 levers acting on the rear caliper
 cylinders.

WHEELS and TYRES

Special light alloy wheels 6½x14"
 Tubeless tyres Michelin 205/70 VR
 14 XWX
 Spare wheel (European version).
 Rim 3¼Bx18"
 Michelin tyre 105 R 18xT

ELECTRIC SYSTEM

Voltage 12 Volts.

AIR CONDITIONING SYSTEM

System Borletti
 Compressor 700 AP

WEIGHTS

Kerb weight kg 1365

PERFORMANCES

Maximum speeds, fully laden, on smooth level road, with run-in, engine:

1st gear	km/h	66
2nd gear	"	95
3rd gear	"	132
4th gear	"	180
5th gear	"	236
Reverse	"	-

Maximum climbable gradients, full y laden, on good road, with run-in engine:

1st gear	45%
2nd gear	35%
3rd gear	25%
4th gear	18%
5th gear	9%
Reverse	-

BRAKING DISTANCE

Test conditions:
Full of fuel and two people on board; dry level road and tyres in good conditions.

ACCELERATION

Standing start kilometre .26"2/10
From 0 to 400 metres 14"4/10

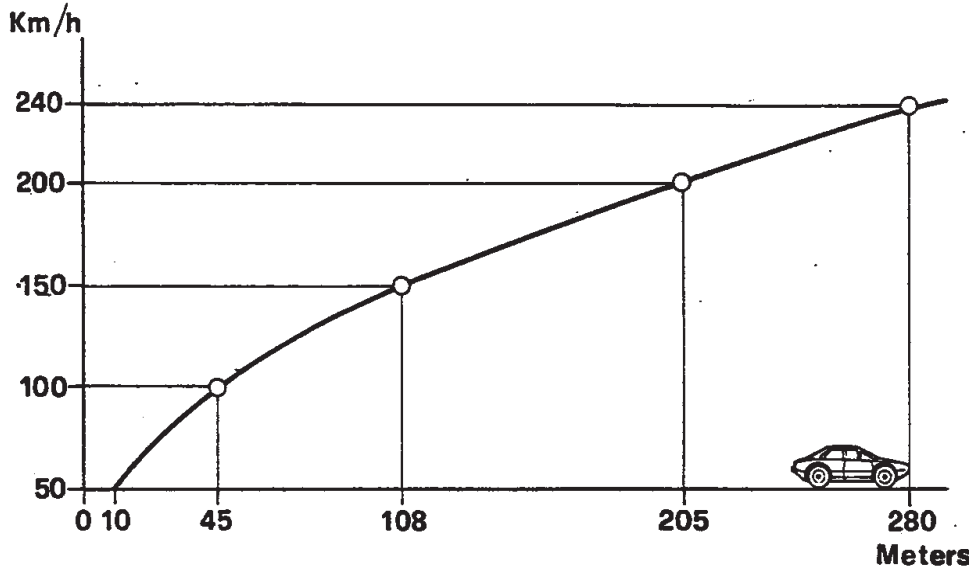

Fig. 2 - BRAKING DISTANCE DIAGRAM.

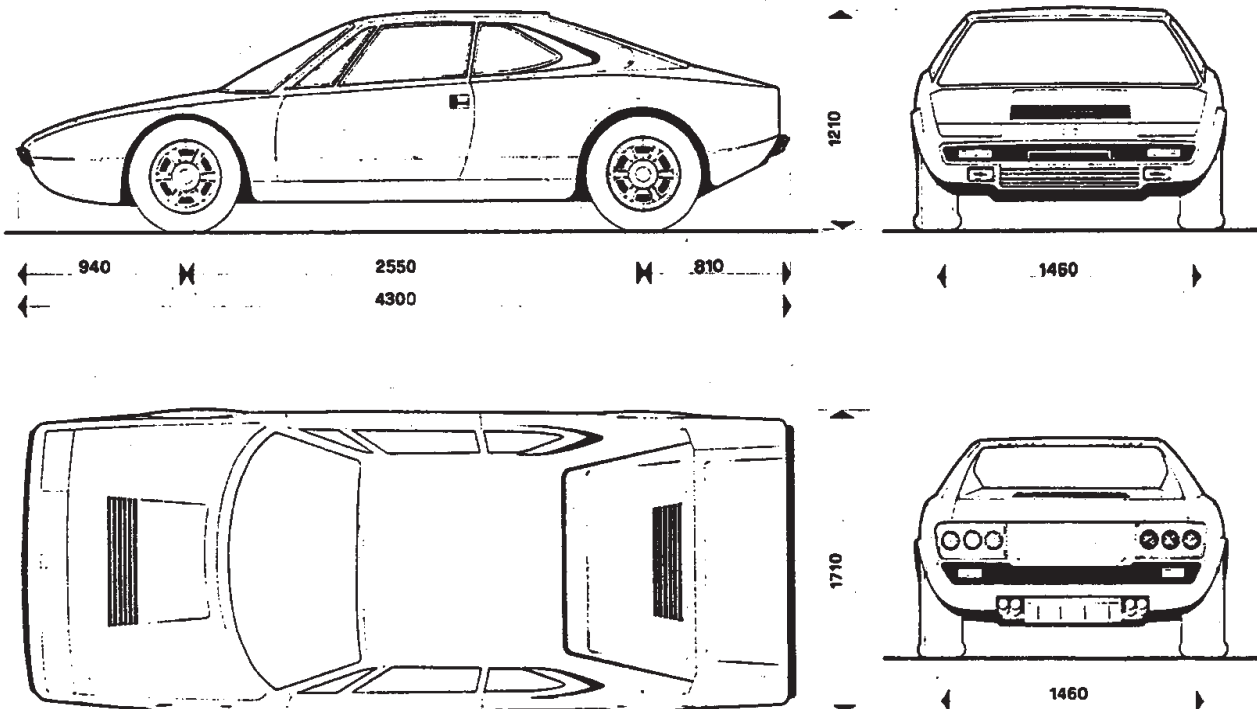

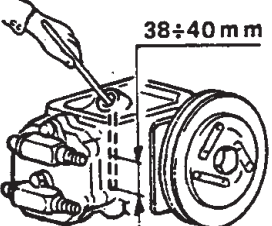



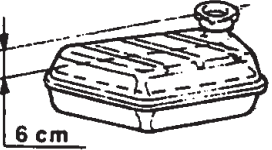
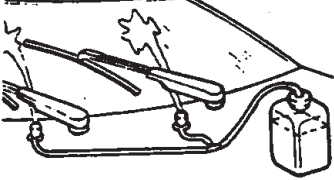
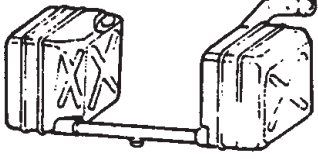
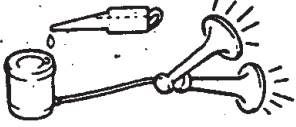

Fig. 3 - MAIN DIMENSIONS of CAR

REFUELLING

ITEMS TO BE SERVICED	Quantity litres	FILL WITH	REFERENCES
ENGINE - Oil sump and filter	9	AGIP SINT 2000 SAE 10 w 50	
GEARBOX-DIFFERENTIAL	4	Agip F1 ROTRA MP SAE 80	
AIR CONDITIONER - Compressor - Circuit capacity	330 cc kg 1	Agip TER 54 FREON 12 ANIDRO	
SHOCK ABSORBERS - Front (each) - Rear (each)	0,190	Agip OSO 35	
BRAKE CIRCUIT	0,58	Fluid ATE Blue S DOT 3 or AGIP F1 DOT 3	
STEERING BOX	0,190 ÷ 0,210	Agip F1 ROTRA MP SAE 90	
COOLING SYSTEM	18	Antifreeze mixture	
WINDSCREEN WASHER BOTTLE	1	Water and glass cleaner mixture.	
FUEL TANKS - Reserve	78 ÷ 80 15	Premium grade 98/100 O.N.	
HORN COMPRESSOR	A few drops	FIAMM oil	

IDENTIFICATION PARTICULARS

Fig. 4 - Car Identification Particulars

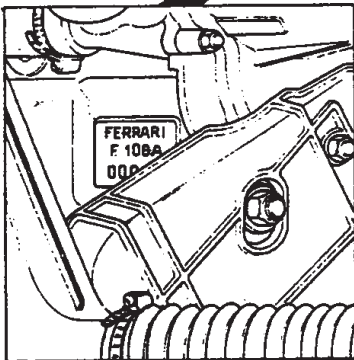
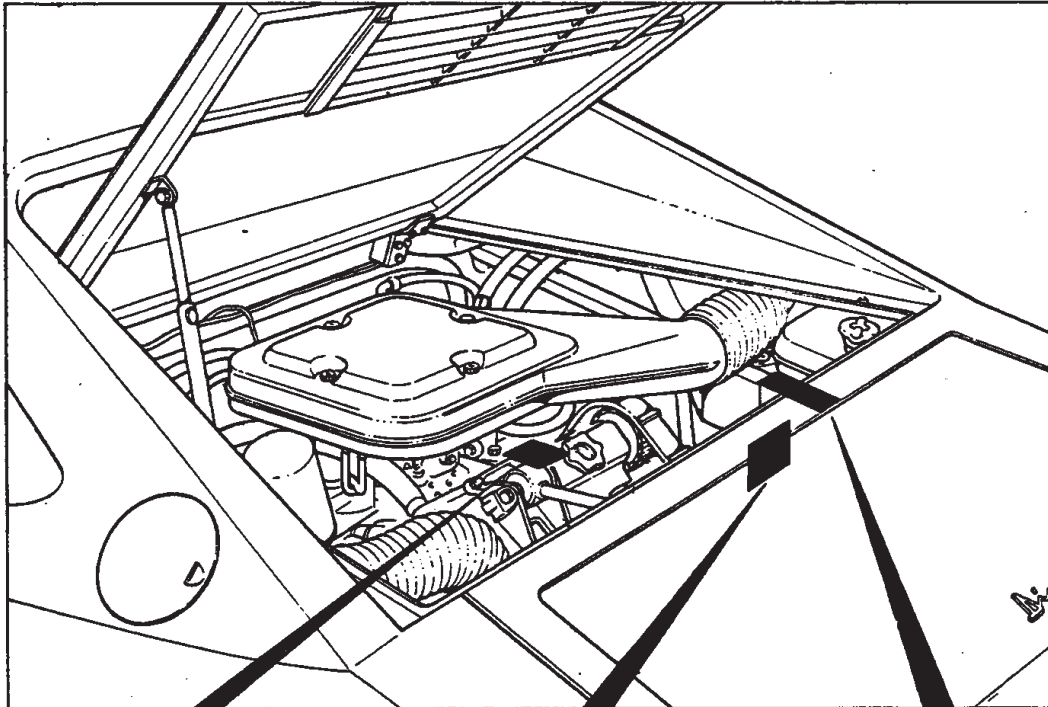

Engine type (F 106A) and identification number.

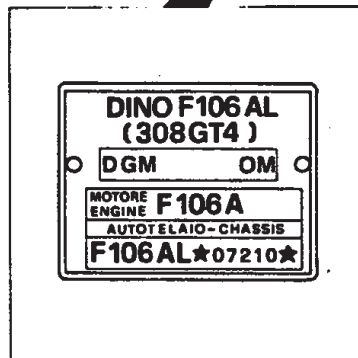

Identification plate: qualification number; engine type; chassis type and number.

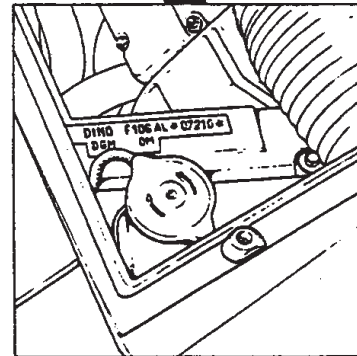

Chassis type (F 106 AL) and identification number.

SPARE PARTS

Instructions to follow when ordering parts.

When ordering spare parts, always specify clearly part description and reference number: you will find it on the "Spare Parts Book". Furthermore, also engine and chassis numbers are requested.

SECTION **B**

ENGINE

	Page
MAIN SPECIFICATIONS	B 3
TROUBLES AND REMEDIES	B 5
CRANKCASE AND LINERS	B11
PISTONS - CONNECTING RODS	B13
CRANKSHAFT - MAIN BEARINGS	B19
CYLINDER HEADS	B23
VALVE MECHANISM	B27
ENGINE ASSEMBLING	B31

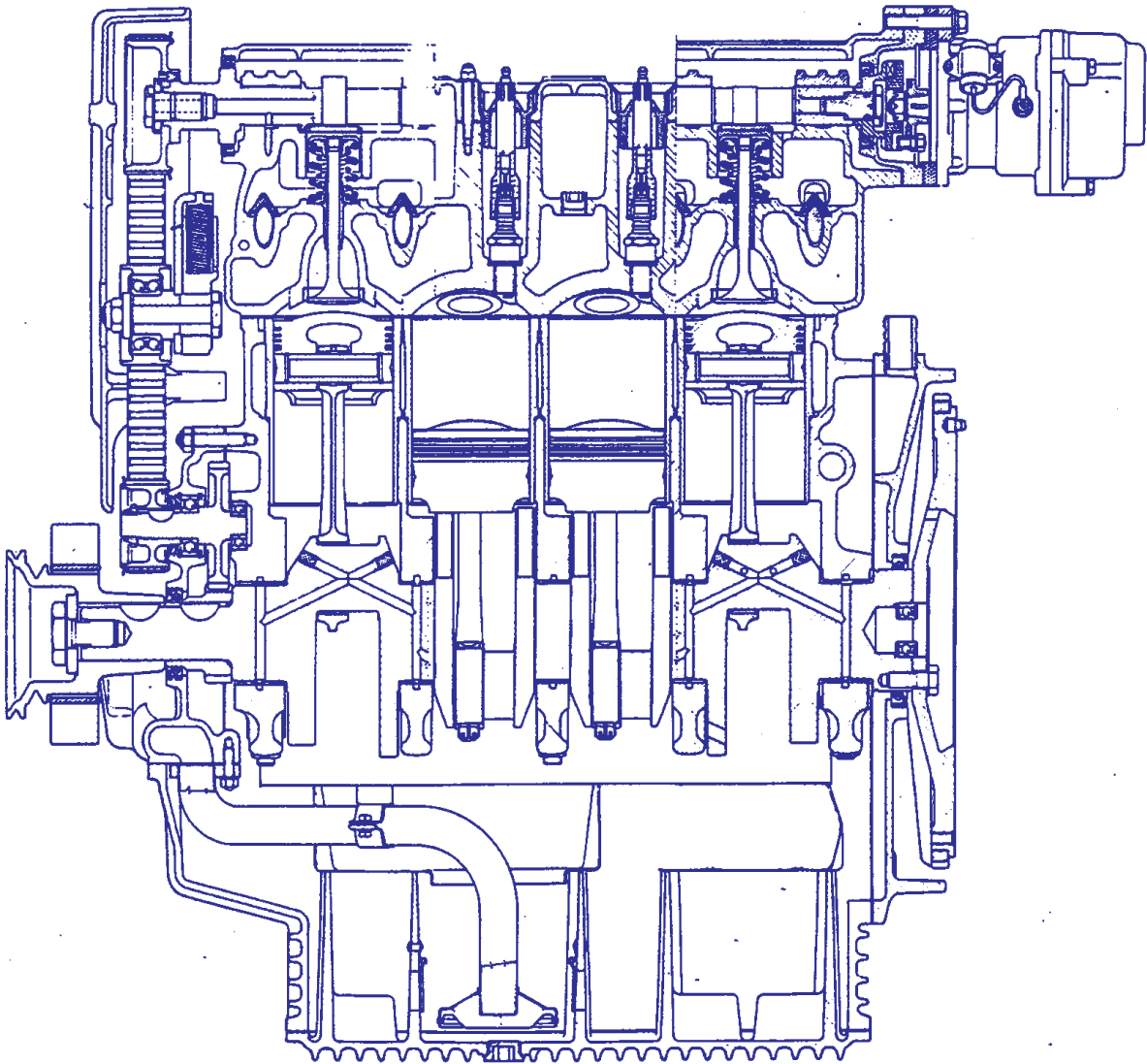

Fig. 1 - LONGITUDINAL SECTION of ENGINE

ENGINE

MAIN SPECIFICATIONS Page B 3

TROUBLE DIAGNOSIS and REMEDIES Page B 5

MAIN SPECIFICATIONS

ENGINE	
Type	F 106 A
Cylinders	8 V 90°
Bore mm.	81
Pistons stroke mm.	71
Displacement cm ³	2926,9
Compression ratio	8,8:1
Maximum engine speed RPM	7000
DIN maximum power cv	250
Corresponding engine speed RPM	7000
Maximum torque kgm	29
Corresponding engine speed RPM	5000
Italian fiscal rating cv	33
CRANKSHAFT	
Type	flat : cranks at 180°
Number of supports	5
Main bearings	thin-wall, anti-fric_ tion lining
Thrust bearings	2 on the rear support
CONNECTING RODS	
Bearings	thin-wall, anti-fric_ tion lining
PISTONS	
Type	conical piston skirt
1st slot ring	4 rings
2nd and 3rd slot ring	chromium plated A.C. type for seal
4th slot ring	conical A.C. type for seal
Hole for pin	ROF scraper ring with clamp
Pin	not misaligned rod small end
VALVE GEAR	
Drive	Toothed belts
Valves	over-head
Camshafts	4 over-head
FUEL SYSTEM	
Electric pump N.1	Corona
Double barrel carburettors N.4	Weber 40 DCNF 35/36/ 37/38
Air filter N.1	cartridge type
Crankcase emission control system.	

Main Specifications (continuation)

LUBRICATION	
Pump	N.1 gear type
Filters	N.1 cartridge type
Pressure relief valve	with spring and adjustment by spacers
Lubrication pressure	kg/cm ² 5,5 ÷ 6,5 at 6000 RPM (100° C)
Oil cooling	by radiator
COOLING	
Type	by centrifugal pump, radiator and thermostatic valve.
Fans	N.2 electric and automatic
Expansion tank	with calibrated valve at 0,9 kg/cm ²
IGNITION	
Type	battery and coils
Firing order	2 distributors with idle retarded operating 1-5-3-7-4-8-2-6
STARTER	
Type	electric motor
Engagement	electro-magnetic
Control	by ignition key
ENGINE MOUNTING	
Type	elastic, on 4 mountings and longitudinal tie-rod.

ENGINE TROUBLE DIAGNOSIS AND REMEDIES

ENGINE DOES NOT START

POSSIBLE CAUSES	REMEDIES
1) Low battery charge.	1) Check and re-charge battery.
2) Battery terminal connections are corroded or loose.	2) Clean, check and tighten terminal clamps.
3) Faulty starter motor.	3) Bench-test the starter motor
4) Faulty starter switch.	4) Replace.
5) Faulty ignition coils.	5) Check and replace if necessary.
6) Cables from coil to distributor and from distributor to spark plugs are loose or broken.	6) Check, remake connections or replace faulty cables.
7) Cracked distributor caps.	7) Replace the caps.
8) Damp or dirt on distributor caps contacts or on current wires.	8) Dry and clean cables and cap contacts.
9) Distributor rotor showing carbonization or wear traces	9) Clean rotor or, if necessary replace.
10) Distributor breaker points are dirty, oxidized or excessively opened.	10) Clean and adjust breaker points opening.
11) Distributor central point of cap is broken or the relevant pressure spring is defective.	11) Replace the central point and relevant spring.
12) Short-circuited condenser or poorly insulated condenser.	12) Bench-test condensers; replace if faulty.
13) Dirty spark plugs or plug gaps too wide.	13) Clean plugs and set exact electrode gap.
14) Flooded carburettor due to incorrect level or dirt between needle and seat.	14) Check and adjust.
15) Fuel pump does not operate.	15) Check fuses, connections, filters and fuel in tank.
16) Dirt or water in fuel lines, in tanks or in carburettors.	16) Remove and carefully clean carburettors; should this inconvenient occur again wash and blow the fuel tank and lines.

ENGINE STALLS

POSSIBLE CAUSES	REMEDIES
1) Idling speed too low.	1) Slightly enlarge the carburettor throttle opening and adjust mixture strength.
2) Idle mixture too lean or too rich.	2) Adjust mixture strength.
3) Flooded carburettor.	3) Follow instructions mentioned in 'Carburettors' chapter (Section C).
4) Dirt or water in fuel lines or in carburettors.	4) Remove and carefully clean the carburettors; should this inconvenient occur again, wash and blow tank and lines.

ENGINE STALLS (continuation)

POSSIBLE CAUSES	REMEDIES
5) Starter engaged with warm engine. 6) Corroded or loose battery terminal clamps. 7) Cables from ignition coils to distributors and from distributors to spark plugs are loose. 8) Sparking plugs are dirty, damp or with excessive gaps or too closed gaps. 9) Contact breaker points are dirty, oxidized or with no flat surfaces. 10) Worn distributor rotor contact. 11) Incorrect ignition advance. 12) Faulty ignition coils and condensers. 13) Overheated engine.	5) Disconnect starter and check warning light. 6) Clean and tighten locking nuts. 7) Check and remake connections 8) Clean and dry sparking plugs then adjust electrodes gap. 9) Clean and adjust contact breaker points gap. 10) Replace rotor. 11) Check. 12) Check and replace if necessary. 13) Check the coolant in water radiator; check water pump and thermostat working conditions; look for possible leaks. Check fans working conditions.

ENGINE LACKS POWER

POSSIBLE CAUSES	REMEDIES
1) Incorrect ignition timing. 2) Accelerator pedal does not reach full throttle position 3) Faulty distributor automatic advance. 4) Too small opening of distributor breaker points. 5) Incorrect valve timing. 6) Faulty distributor micro-switch. 7) Weak compression. 8) Sparking plugs are dirty, damp or with excessive gap. 9) Sparking plugs are too worn or of a not recommended type. 10) Fuel has a low octane number 11) Worn cams. 12) Fuel mixture too rich or too lean.	1) Check and carry out correct timing. 2) Check nature of obstruction and remove it. 3) Overhaul distributor as explained under relevant heading. 4) Adjust contacts opening. 5) Check and adjust if necessary. 6) Check and replace if necessary. 7) Check valves seal and cylinders seal. 8) Clean sparking plugs and adjust exact electrodes gap. 9) Replace plugs or use the recommended type. 10) Use the recommended fuel. 11) Check timing; replace the camshaft if necessary. 12) Check carburettor jets size.

ENGINE LACKS POWER (continuation)

POSSIBLE CAUSES	REMEDIES
13) Some carburettor throttles do not open completely.	13) Check controls.
14) Too weak valve springs due to deformation.	14) Check following the table on page B 24; replace springs if necessary.
15) Poor fuel feeding due to faulty pump or obstructed filters.	15) Check, clean, replace faulty items if necessary.
16) Picking-up between crankshaft and bearings or valves and guides.	16) Check and replace faulty items if necessary

ENGINE MISSES AT HIGH SPEEDS

POSSIBLE CAUSES	REMEDIES
1) Poor fuel feed.	1) Obstructed electric pump and filters, too warm fuel, tanks almost out of reserve.
2) Obstructed air filter.	2) Clean, blow or replace it if necessary.
3) Filters on lines or on carburettors are partially obstructed.	3) Clean filters.
4) Sparking plugs are dirty, damp or have uncorrectly adjusted gap.	4) Clean and adjust gap; replace if necessary.
5) Some faulty or not well closed sparking plugs lead to self-ignition.	5) Check sparking plugs condition and type.
6) Ignition timing advance is higher than values recommended for high speeds.	6) Check using stroboscope at 5000 engine RPM.
7) Faulty distributor micro-switch.	7) Check and replace if necessary
8) Too weak or deformed distributor breaker points springs.	8) Check and replace worn items if necessary.
9) Some valve springs are deformed and have insufficient load.	9) Check and replace springs.
10) Some valves do not run freely in proper guides and do not close well.	10) Check and replace valves and guides if necessary.
11) One or more carburettors flooded.	11) Check needle valve or replace if worn out.
12) Water in fuel.	12) Carefully clean the whole system.

ENGINE MISFIRES IN ACCELERATION

POSSIBLE CAUSES	REMEDIES
1) Sparking plugs are dirty, damp or have excessive gap.	1) Check, clean and adjust electrodes gap.

ENGINE MISFIRES IN ACCELERATION (continuation)

POSSIBLE CAUSES	REMEDIES
2) Incorrect ignition timing.	2) Check static advance and retard between R1 and R2.
3) Incorrect idle mixture.	3) Adjust it.
4) Incorrect carburettor throttle opening synchronization.	4) Check and adjust.
5) Faulty fuel pump.	5) Check connections tightening, lines and filters cleaning.
6) Faulty acceleration pumps.	6) Check stroke, jets cleaning and cylinder condition.
7) Incorrect compression in cylinders.	7) Check compression using manometer.
8) Engine valves are burnt or damaged.	8) Check and replace valves.
9) Valve clearance wrongly adjusted.	9) Adjust correctly.
10) Some flooded carburettors due to dirt between needle and seat.	10) Clean float chambers and carburettors filters.
11) Incorrect float chamber level.	11) Check level.
12) Air leakage between manifolds and heads and between heads and exhaust manifolds	12) Check manifolds and flanges tightening.
13) Excessive clearance between carburettor controls	13) Check and replace faulty items.
14) Automatic advance does not operate.	14) Test on bench.
15) Distributor breaker points are dirty and have incorrect opening.	15) Check, clean and adjust.
16) Distributor microswitch wrongly adjusted.	16) Check and re-set adjustment.

NOISY TAPPETS and VALVES

POSSIBLE CAUSES	REMEDIES
1) Excessive clearance between cam and shim on valve.	1) Adjust and replace shims.
2) Some cams or shims are worn	2) Check and replace camshaft and thimble.
3) Some broken valve springs.	3) Replace broken springs.
4) Excessive clearance between thimble and guide hole.	4) Check
5) Some valve stems not free in proper guides.	5) Check
6) Timing belts are too loose or too worn.	6) Check stretcher conditions and belts wear.

NOISY CONNECTING ROD PINS

POSSIBLE CAUSES	REMEDIES
<ol style="list-style-type: none"> 1) Excessive clearance between con.rod bearings and crankshaft pins. 2) Poor oil delivery. 3) Unsuitable oil. 4) Too low oil pressure. 5) Excessive clearance between piston pins and con.rod bushes. 	<ol style="list-style-type: none"> 1) Dismantle, check bearings and pins wear. If necessary replace bearings and grind shaft. 2) Check oil pump and lines. 3) Replace oil. 4) Check oil pump valve. 5) Dismantle, check pins and bushes wear. If necessary replace worn items.

ENGINE VIBRATION

POSSIBLE CAUSES	REMEDIES
<ol style="list-style-type: none"> 1) Faulty ignition or excessive advance. 2) Faulty carburation. 3) Faulty carburettor synchronization. 4) Excessive clearance between main bearings and pins. 5) Connecting rods and pistons not equal in weight. 6) Incorrect clearance between cams and shims. 7) Irregular compression in cylinders. 8) Flexible mountings/engine tie rod worn or too stiff. 9) Engine flywheel/clutch assembly out of balance. 10) Faulty cylinders. 	<ol style="list-style-type: none"> 1) Check and overhaul ignition system. 2) Check and adjust. 3) See relevant heading on page 20. 4) Check diameter of main journals. 5) Check assemblies and equalize weights. 6) Adjust. 7) Check compression in each cylinder. 8) Check and replace if necessary. 9) Balance flywheel and clutch assembly. 10) Find out faulty cylinders then check sparking plugs and wires.

EXCESSIVE OIL PRESSURE

POSSIBLE CAUSES	REMEDIES
<ol style="list-style-type: none"> 1) Unsuitable engine oil - too thick. 2) Oil pressure valve is locked or incorrectly adjusted. 3) Obstructed oil lines. 	<ol style="list-style-type: none"> 1) Change oil with correct type. 2) Check and replace faulty items if necessary. Adjust again as prescribed. 3) Carefully wash oil lines and replace filter.

TOO LOW OIL PRESSURE

POSSIBLE CAUSES	REMEDIES
<ol style="list-style-type: none"> 1) Too high oil temperature. 2) Engine oil not suitable for working conditions. 3) Excessive clearance between main journals, crankpins and relevant bearings. 	<ol style="list-style-type: none"> 1) Reduce engine revs. 2) Change oil with correct type. 3) Dismantle, check crankshaft and, if necessary, grind it. Replace bearings.

TOO LOW OIL PRESSURE (continuation)

POSSIBLE CAUSES	REMEDIES
4) Oil pressure adjusting valve faulty or jammed.	4) Check.
5) Obstructed oil inlet filter.	5) Remove sump cover then clean filter.
6) Faulty oil pressure gauge.	6) Check and replace if necessary.
7) Too low oil level in sump.	7) Check and re-set level.

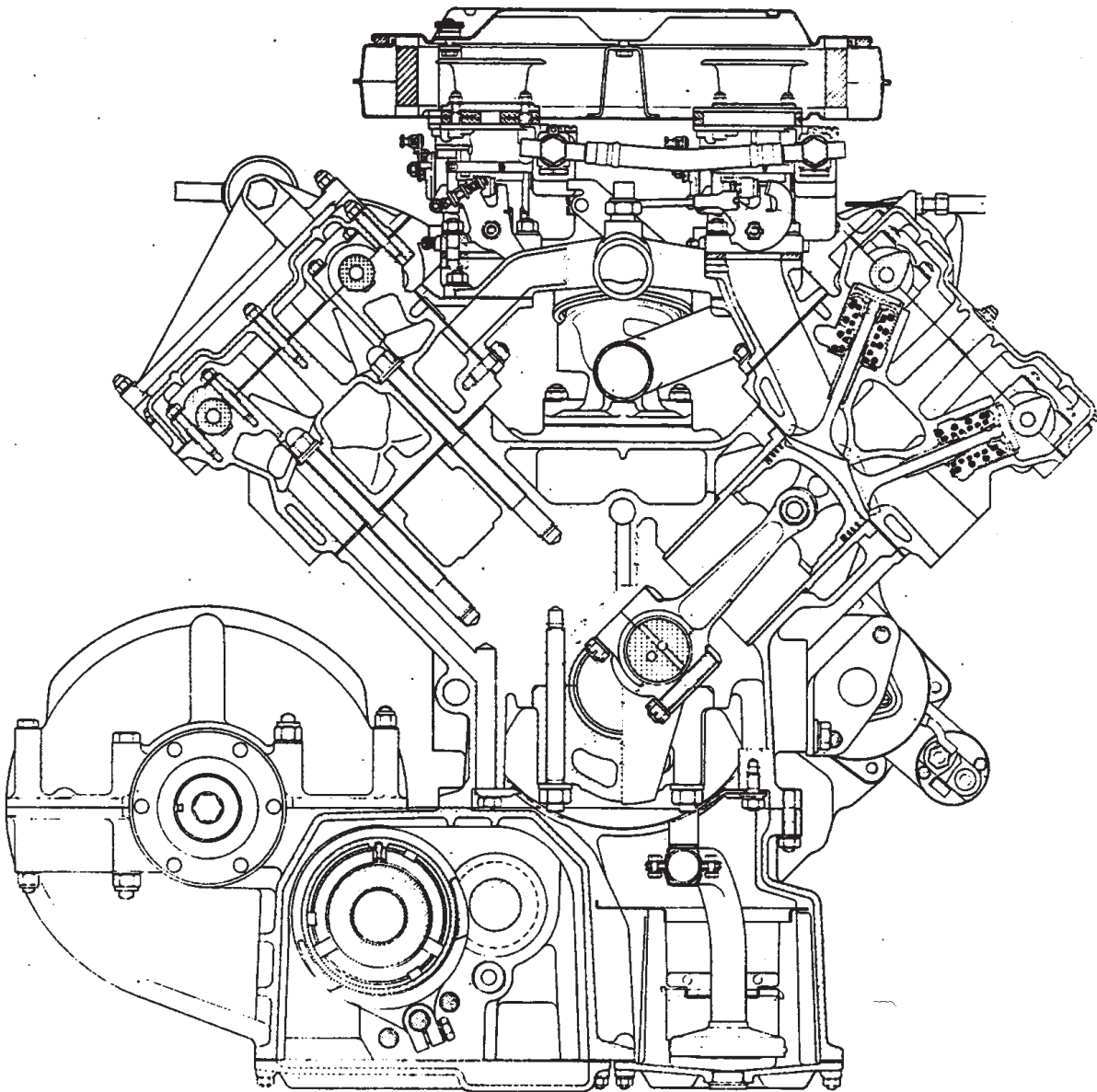

Fig. 2 - Cross section of engine.

C R A N K C A S E A N D L I N E R S

MAIN SPECIFICATIONS	Page B 11
GENERAL INFORMATION	" B 11
CHECKING MAIN BEARINGS	" B 11
CYLINDER LINERS	" B 12

MAIN SPECIFICATIONS

DESCRIPTION	mm
Liners seats diameter in crankcase	87,000 + 87,035 93,000 + 93,022
Liners nominal diameter	81,000 + 81,020
- 1st oversize diameter	81,150 + 81,170
- 2nd oversize diameter	81,300 + 81,320
Liner maximum wear (on diameter)	0,080 + 0,100
Allowed ovalization and taper ratio	0,010 + 0,015
Liners grinding Roughness μ	0,6 + 0,8
Liners protrusion from crankcase on heads surface	0,01 + 0,05
Diameter of main bearing housing	66,675 + 66,688

GENERAL INFORMATION

Crankcase is in light aluminium alloy at high endurance; removable liners in special cast iron. When disassembling the engine, always carefully clean the engine block: take off the relevant plugs then flush with oil all lubrication ways.

CHECKING MAIN BEARINGS

Put the suitable 361/AS/4736 boring bar of mm. 66,675 -0,01/ -0,02 in diameter, in the main bearing housing; then tighten the mountings at the tightening torque shown on table "Tightening Torque" (page M 5). Assemble the cylinder heads with used gaskets, lock the nuts following instructions shown on the same table.

In case the boring bar runs without any effort, that means there is no deformation or there is a very slight one.

If the gauge effort is more or less remarkable, touch up the housing using a scraper starting from the central support.

After having put the boring bar efforts into standard conditions, smooth the bearing housings using the AV-240 lapping tool which has been previously spreaded with cromax or excelsior paste and oil.

CYLINDER LINERS

Liners are free assembled in their housings.

They are supplied ready to be assembled, that is with prescribed allowances.

Maximum allowed wear on diameter is of mm. $0,08 + 0,10$ measured at approx. 10 mm. from the face of cylinder heads gasket.

Should wear exceeds this value, it is advisable to replace cylinder liners.

Ovalization and taper ratio of liners on cylinder block must not exceed mm. $0,010 + 0,015$.

Only in case of imperative reasons it is advisable to grind.

When effecting this operation, cylinder liner should be removed from engine block; then with proper grinding bring the inner diameter size up to the measure corresponding to the 1st or 2nd oversize.

During the grinding operation carefully check the perpendicularity between grinded surface and head surface ($\perp 0,02$).

The roughness degree of grinding should be of $0,6 + 0,8 \mu$

Before re-assembling the cylinder liners (removed for a whatever reason), carry out a careful cleaning and replace seal rubbers.

Liners protrusion from the gasket face, without seal ring A, must be between mm. $0,01 + 0,05$ and it should be equal for all the liners of each cylinder file and near to mm. $0,03$.

Use gauge 542-CS-6768 for this checking.

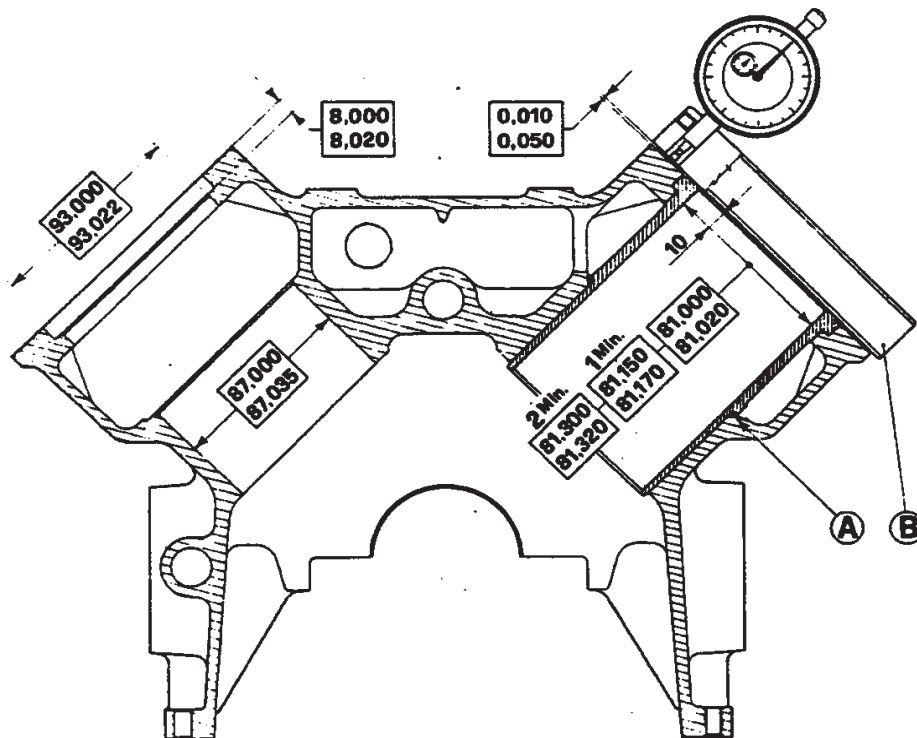

Fig. 3 - LINER HOUSING IN CRANKCASE.

A - seal ring; B - gauge 542-CS-6768.

PISTONS - CONNECTING RODS

MAIN SPECIFICATIONS Page B 13
 CLEANING " B 15
 CHECKING PISTONS " B 15
 CHECKING CLEARANCE OF PISTON RING ENDS " B 15
 PISTON RINGS ASSEMBLY " B 15
 CHECKING CONNECTING RODS " B 15
 CONNECTING ROD BEARINGS " B 16

MAIN SPECIFICATIONS

DESCRIPTION	mm
Standard piston diameter measured perpendicular to pin axis. - at 8,5 mm. from piston base (class A) (see fig. 4) (class B)	80,970+80,980 80,960+80,970
Piston/cylinder liner coupling (measured at 8,5 mm. from the base). - assembling clearance - limit of wear	0,020 + 0,060 0,10
Range of oversize spare piston 1st oversize (on diameter) 2nd oversize (on diameter)	+ 0,15 + 0,30
Height of piston ring grooves 1st-2nd-3rd grooves 4th groove	1,210 + 1,235 3,010 + 3,035
Piston ring size 1st chromed AC ring 2nd conical AC ring 3rd conical AC ring 4th ROF ring with clamp	1,178+1,190x3,48+3,72 1,178+1,190x3,48+3,72 1,178+1,190x3,48+3,72 2,978+2,990x2,380+2,520
Range of oversize spare ring 1st oversize (on diameter) 2nd oversize (on diameter)	+ 0,15 + 0,30
Rings/piston slots coupling (vertically) - 1st chromed ring - AC seal (clearance) - 2nd conical ring - AC seal (clearance) - 3rd conical ring - AC seal (clearance) - 4th ROF ring with clamp (clearance) - limit of wear	0,020 + 0,057 0,020 + 0,057 0,020 + 0,057 0,020 + 0,057 0,070
Gap between ends of piston rings inserted into cylinder liners: - 1st chromed ring - AC seal - 2nd conical ring - AC seal - 3rd conical ring - AC seal - 4th ROF oil control ring with clamp	0,30 + 0,45 0,30 + 0,45 0,30 + 0,45 0,15 + 0,25
Diameter of piston pin bore	18,500 + 18,506

Main Specifications :Pistons-Pins-Rings-Con.Rods-Bearing (continuat.)

DESCRIPTION	mm
Diameter of standard piston pin	18,494 + 18,500
Piston pin/piston boss coupling - assembling clearance - limit of wear	0,000 + 0,012 0,05
Diameter of con-rod small end bearing seat	21,500 + 21,521
Outside diameter of small end bush Inner diameter of small end bush Pin/small end coupling - limit of wear	21,535 + 21,548 18,515 + 18,535 0,015 + 0,041 0,050
Piston pin bush/ con-rod hole coupling: - interference	0,014 + 0,048
Diameter of con-rod big end bearing seat	47,129 + 47,142
Thickness of standard big end bearings	1,714 + 1,723
Range of undersize con-rod big end bearing 1st undersize (on diameter) 2nd undersize (on diameter) 3rd undersize (on diameter)	- 0,254 - 0,508 - 0,762
Big end bearings/crankpins coupling on crank- shaft - assembling clearance - limit of wear	0,046 + 0,089 0,12

CLEANING

Remove all fouling from piston crown and ring grooves; for this operation use a split piston ring.
 Remove all dirt from lubrication holes inside piston and connecting rod. After cleaning, carefully check that parts do not show any slit or damage that would require their replacement.
 A Magnaflux control is advisable.

CHECKING

Pistons are graded in two classes marked with A and B letters which are printed on piston crown.
 The difference between the two classes is of 0,01 mm. in diameter.
 The difference in weight can change from 0 to 2 grammes.
 Pins are assembled in piston by a slight shrinking and are held back on their sides by expansion rings. These pins belong to a sole class since the difference in their diameter does not exceed 0,01 mm.

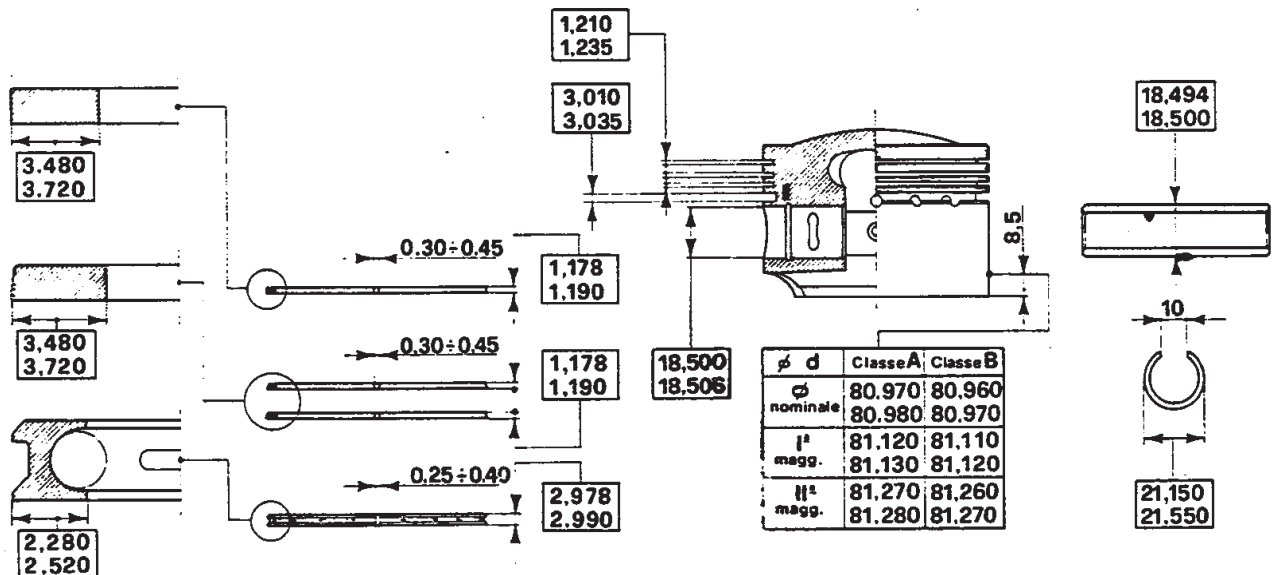

Fig. 4 - MAIN SPECIFICATIONS OF PISTON, PIN AND RINGS.

CHECKING PISTON RING ENDS CLEARANCE

Before fitting rings on pistons, insert rings into liners then check ends clearance: it must correspond to values shown in figure 4.

ASSEMBLING PISTON RINGS

To make easier the assembling of rings on pistons, use the proper tool.
 Afterwards, position ring clefts in a way that they are approx. 90° out of phase.

CHECKING CONNECTING RODS

When overhauling the engine and above all when replacing bushes for piston pin, always check parallelism between axle of con.rod small end and eye with assembled bush: it must be within 0,03 mm. measured at a distance of 50 mm.

A Magnaflux control is advisable. Connecting rods are classified according to their weight with a letter printed on the stem as shown on relevant table.

When replacing con-rods, make sure that new con-rods are marked with the same letters: that is have the same weight.

Note: When removing con-rods, always replace the nuts on con-rods tightening bolts.

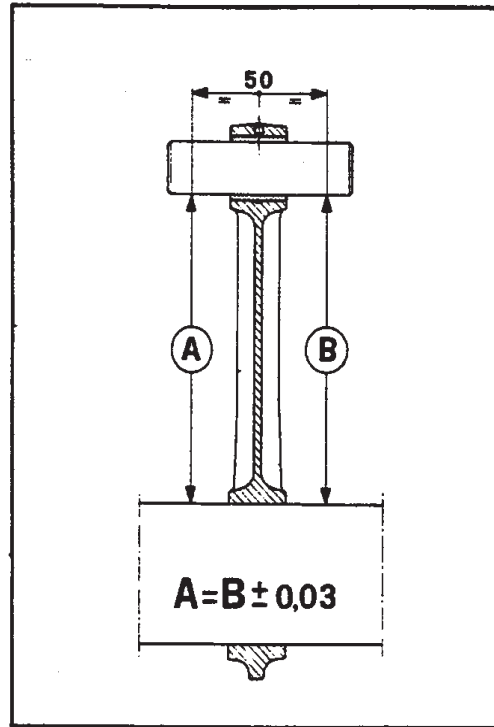

Fig. 5 - CHECKING CON. ROD PARALLELISM

LETTER	CORRESPONDING in gr.	LETTER	CORRESPONDING in gr.	LETTER	CORRESPONDING in gr.
A	520 + 524	H	548 + 552	Q	576 + 580
B	524 + 528	I	552 + 556	R	580 + 584
C	528 + 532	L	556 + 560	S	584 + 588
D	532 + 536	M	560 + 564	T	588 + 592
E	536 + 540	N	564 + 568	U	592 + 596
F	540 + 544	O	568 + 572	V	596 + 600
G	544 + 548	P	572 + 576		

Each con-rod is assembled in the corresponding cylinder with numbers turned downwards

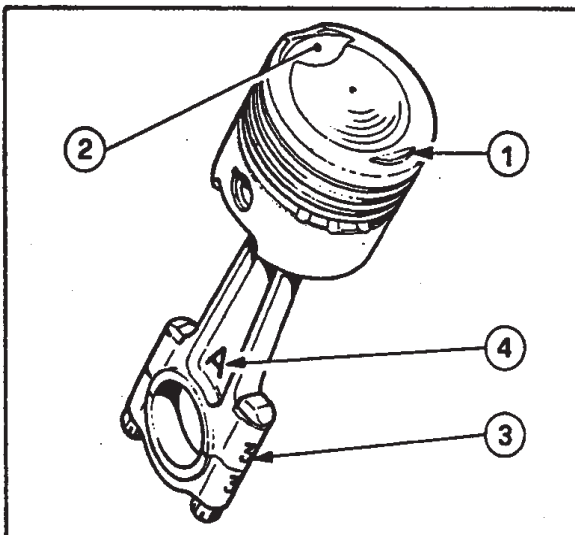

Fig. 6 - CON. ROD/PISTON ASSEMBLY.

- 1 - Exhaust valve seat.
- 2 - Intake valve seat.
- 3 - Location of the cylinder number to which the con-rod belongs.
- 4 - Letter classifying con-rod weight.

BIG END BEARINGS

Thin-wall bearings must never be refaced to avoid the removal of anti-friction layer.

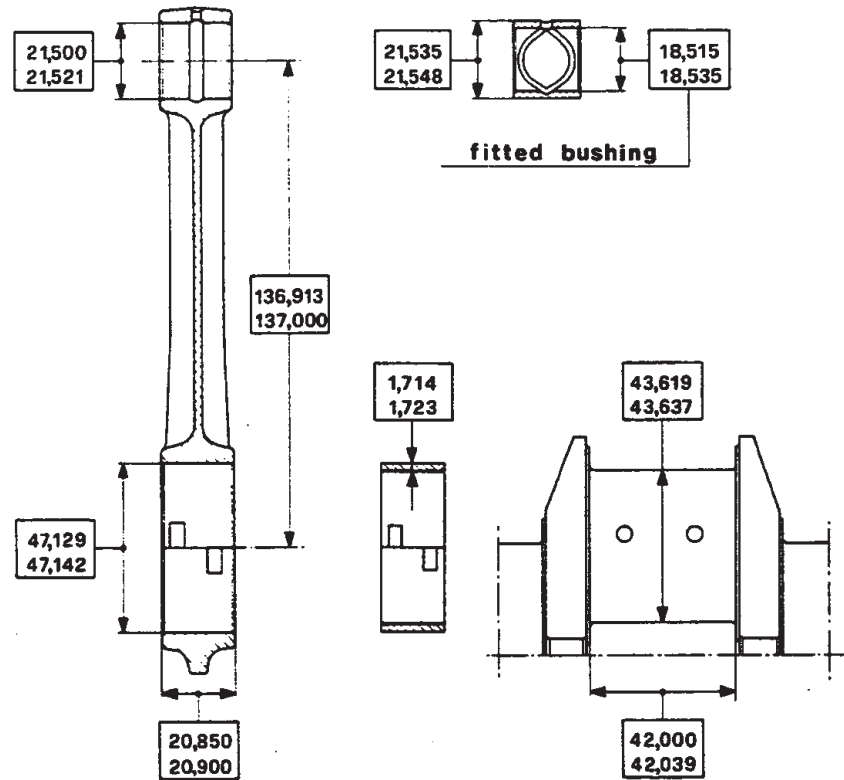

Fig. 7 - MAIN DATA OF CON. ROD, BEARING AND CRANKPIN

CRANKPIN DIAMETERS (crankshaft)

BIG END BEARINGS THICKNESSES

Nominal diameter		43,619 ÷ 43,637
1st undersize	0,254	43,365 ÷ 43,383
2nd undersize	0,508	43,111 ÷ 43,129
3rd undersize	0,762	42,857 ÷ 42,875

Nominal Thickness	1,714 + 1,723
+ 0,127	1,841 + 1,850
+ 0,254	1,968 + 1,977
+ 0,381	2,095 + 2,104

Replace any item that shows deep grooving or wear signs. Make sure of big end bearings good conditions and fit bearings in proper housings; then tighten bolts at tightening torque of 6,6 kgm. Using a dial gauge measure bearing bore and crankshaft pins diameter. If the clearance is lower than the limit of wear, the same bearings can be used and the crankpin diameter does not change. If the clearance is higher, replace the bearings with oversize ones then bring crankpins to the values shown in the relevant table.

C R A N K S H A F T - M A I N B E A R I N G S

MAIN SPECIFICATIONS Page B 19
 CHECKING JOURNALS AND CRANKPINS " B 20
 CHECKING CRANKSHAFT END FLOAT " B 20
 CHECKING OIL SEALS " B 21
 CHECKING CLUTCH SHAFT BEARING " B 21
 BALANCING " B 21

MAIN SPECIFICATIONS

DESCRIPTION	mm
Standard diameter of main bearing pins	62,966+62,979
Diameter of main bearing housings	66,675+66,688
Thickness of standard main bearings	1,828+1,835
Undersizes on diameter of spare main bearings	0,254;0,508;0,762
Standard diameter of crankpin	43,619+43,637
Main bearings/journals coupling - assembling clearance - limit of wear	0,026+0,064 0,15
End play of con-rod connected to crankshaft	0,200+0,339
Length of rear journal between two shoulders	36,000+36,039
Width of thrust washers seats for rear bearing (crankcase)	31,130+31,180
Thickness of thrust washers for rear bearing	2,310+2,360
Oversizes of thrust washers (as spare part)	+ 0,25
Crankshaft end float with thrust washers - assembling clearance - limit of wear	0,100+0,240 0,30
Maximum acceptable tolerance on journals alignment	0,02
Maximum acceptable tolerance on the parallelism of crankpins in comparison with journals.	0,01
Maximum out-of-round of journals and crankpins after grinding	0,01
Maximum taper of journals and crankpins after grinding	0,01
Perpendicularity of flywheel mounting flange surface in relation to the rotation axis. At a distance of 48 mm. from the axis, permissible tolerance is:	0,025
Journals / crankpins surface hardness	HRC ≥ 56
Journals / crankpins surface condition	μ 0,2

CHECKING AND REFACING JOURNALS AND CRANKPINS

Journals and crankpins get worn with difficulty because of the high hardness of working areas and the filtering efficiency of lubrication oil.

If journals and crankpins have to be undersize, measure the pins diameter with a micrometer then establish, in accordance with the relevant table, which undersize needs to be reduced.

JOURNAL DIAMETER

Nominal diameter		62,966+62,979
1st undersize	0,254	62,712+62,725
2nd undersize	0,508	62,458+62,471
3rd undersize	0,762	62,204+62,212

THICKNESS OF MAIN BEARINGS

Nominal Thickness	1,829+1,835
+ 0,127	1,956+1,962
+ 0,254	2,083+2,089
+ 0,381	2,210+2,216

Usually, after the first undersize, journals and crankpins have still the superficial hardness higher than the minimum required value. For the second undersize it is necessary to re-nitride the shaft. It is then advisable to grind the journals with machining allowance of 1/10 on the diameter (to remove after nitriding) while the crankpins must be grinded on measure before nitriding.

CHECKING CRANKSHAFT END FLOAT

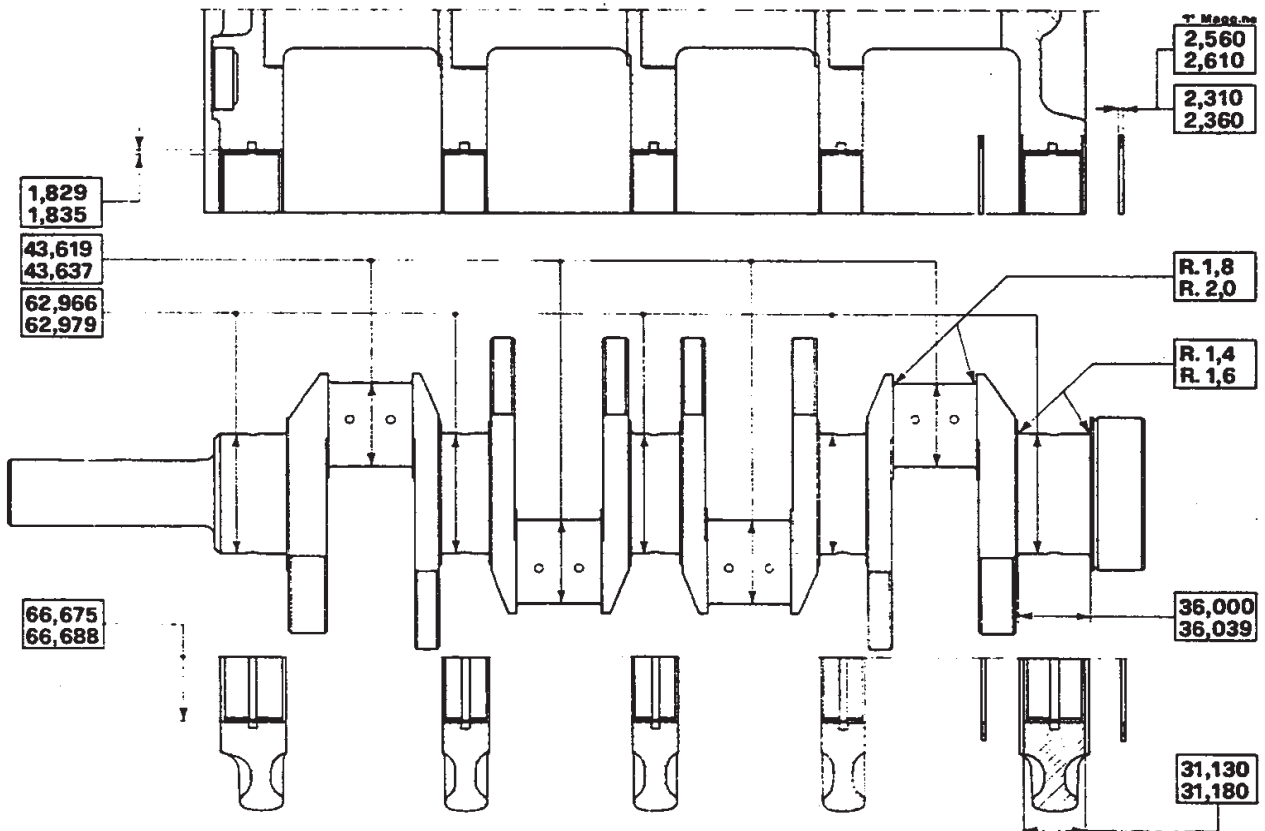

Fig. 8 - MAIN DATA of MAIN JOURNALS, CRANKPINS and THRUST WASHERS

After having assembled the crankshaft on the crankcase, check the end float between the thrust rings on the rear bearing and the crankshaft shoulders.

Using a screwdriver, move the shaft in an axial way then with a probe measure the distance between shaft and thrust washer: it must be within the value of $0,100 \pm 0,240$ mm. If the clearance is higher than the maximum acceptable value, replace the thrust rings with 1st oversize ones (0,250 mm.).

Make sure that the grooves on one thrust ring side are turned towards the shoulder of the crankshaft.

CHECKING OIL SEALS

When overhauling the engine, it is necessary to replace the two oil seals and springs which are to the ends of the crankshaft even though their conditions are still acceptable. Replace also all gaskets of the junction plans.

CHECKING MAINSHAFT BEARING

If the bearing is noisy or runs roughly, replace it.
For this operation use the proper puller.

BALANCING

Crankshaft, flywheel and torsional damper are supplied as spare parts already individually balanced; therefore each item can be replaced without effecting any new balancing.

CYLINDER HEAD

MAIN SPECIFICATIONS	Page B 23
CHECKING CYLINDER HEADS	" B 25
CLEANING AND CHECKING	" B 25
DISMANTLING VALVES AND CONTROLS	" B 25
CHECKING VALVE SPRINGS	" B 26

MAIN SPECIFICATIONS

DESCRIPTION	mm
Height of heads	127 + 127,2
Valves layout	V of 46°
Diameter of valve guide seats in cylinder head	13,000 + 13,018
Outside diameter of valve guides	13,050 + 13,068
Inside diameter of valve guides pressed into cylinder head	(inlet) 8,000 + 8,015 (exhaust) 8,000 + 8,015
Valve guides and seats in head : assembling interference	0,032 + 0,068
Diameter of valve stems	(inlet) 7,960 + 7,975 (exhaust) 7,960 + 7,975
Valve stem and guide coupling:	
- assembling clearance	(inlet) 0,025 + 0,055 (exhaust) 0,025 + 0,055
- limit of wear	0,10
Maximum runout between stem and valves head	(inlet) 0,02 (exhaust) 0,02
Thimble seat diameter	37,015+37,045
Outside diameter of thimble	36,975+36,995
Clearance between thimble and relevant seat:	
- assembling clearance	0,020+0,070
- limit of wear	0,100
Inside diameter of inlet valve seat	36,900+37,100
Inside diameter of exhaust valve seat	33,900+34,100
Valve face angle	(inlet) 45° ± 5' (exhaust) 45° ± 5'
Top diameter of inlet valve seat	44,220+44,240

Main Specifications : Cylinder head (continuation)

DESCRIPTION	mm	
	Lower diameter of inlet valve seat	44,090+44,110
Top diameter of exhaust valve seat	41,220+41,240	
Lower diameter of exhaust valve seat	41,090+41,110	
Inlet valve seat housing	(top diameter)	44,060+44,080
	(lower diameter)	44,000+44,020
Exhaust valve seat housing	(top diameter)	41,060+41,080
	(lower diameter)	41,000+41,020
VALVE SPRINGS	Inside spring	Outside spring
Free length of spring	40,4	42,1
Length with valve closed	35,05	38,65
Length with valve opened	26	29,6
Length of wholly compressed spring	24	25,5
Load with valve closed	kg. 12,3±0,5	16,6±0,6
Load with valve opened	kg. 33,1±1,2	60,3±2,1

CHECKING CYLINDER HEADS

The two cylinder heads are in aluminium alloy with hemispherical combustion chamber and inserted valve seats in cast iron. The seats fitting must be effected after checking of housings and rings diameter; the interference must be of $0,07 \pm 0,11$ mm. on the small diameter side and $0,14 \pm 0,18$ on the bigger diameter side. For inserting rings in seats, heat the heads in a suitable furnace at a temperature of $190^\circ \pm 200^\circ$ C. while the rings will get cooled by means of carbon dioxide keeping them in it for $5' \pm 6'$. All finishing operations regarding seats must be carried out after they have been fitted to the heads. Each valve is provided with two concentric helical springs. It is advisable to replace the springs any time the engine is overhauled and also when they are deformed or with the load reduced of 3-5 kg. with closed valve. When the valve seats wear is of $0,6 \pm 0,7$ mm. they must be replaced. To avoid any damage to head housing, it is necessary to withdraw the seats by boring them.

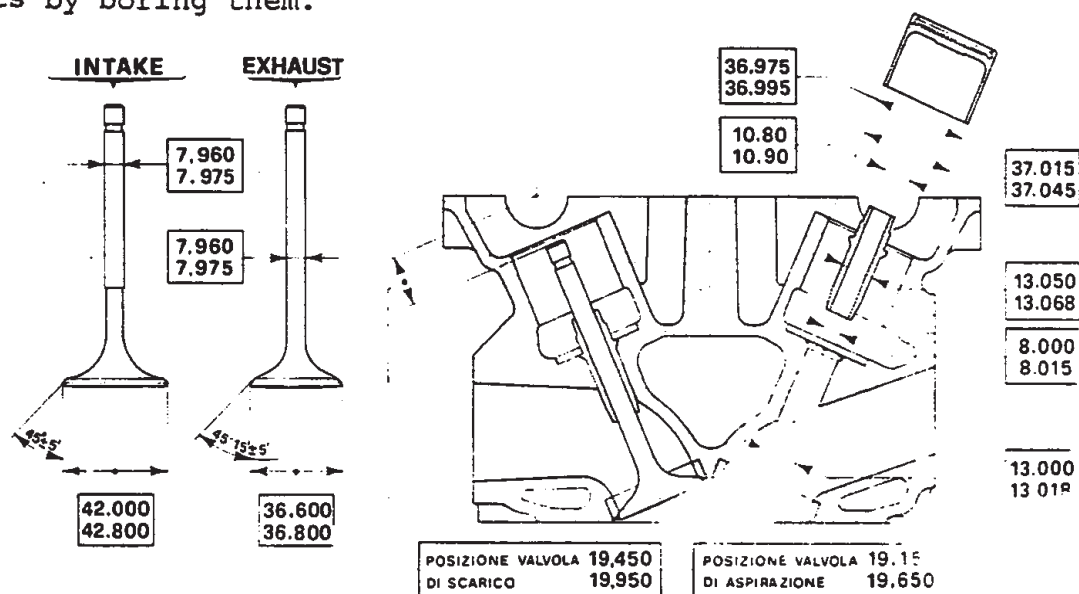

Fig. 9 - MAIN DATA of VALVES and GUIDES.

CLEANING AND CHECKING

Remove carbon deposits from combustion chambers and intake and exhaust pipes. Clean with oil, better if under pressure.

- Check threaded holes for sparking plugs.
- Check that valve seats do not move in proper housing.
- Check the head faces on the crankcase and camshaft housings.
- Check that there are no water leaks (Test pressure 8 ± 10 kg/cm²).
- Check thimble seats.

DISMANTLING AND CHECKING VALVES

Use the tool AV-508 to remove the valves.

- Check valve stem wear with a micrometer caliper.
- Check wear and flat surface at the stem end.
- Make sure of the perfect concentricity between valves and seats; check also the clearance between valves and guides.
- Check inner size and ovalization of valve guides.
- Check that valve guide hole surface is not scored or seized.
- Check with plug gauge 152-CS-7431 the inner size and ovalization of thimble seats.
- Make sure that oil seals on valve guides are in perfect conditions.

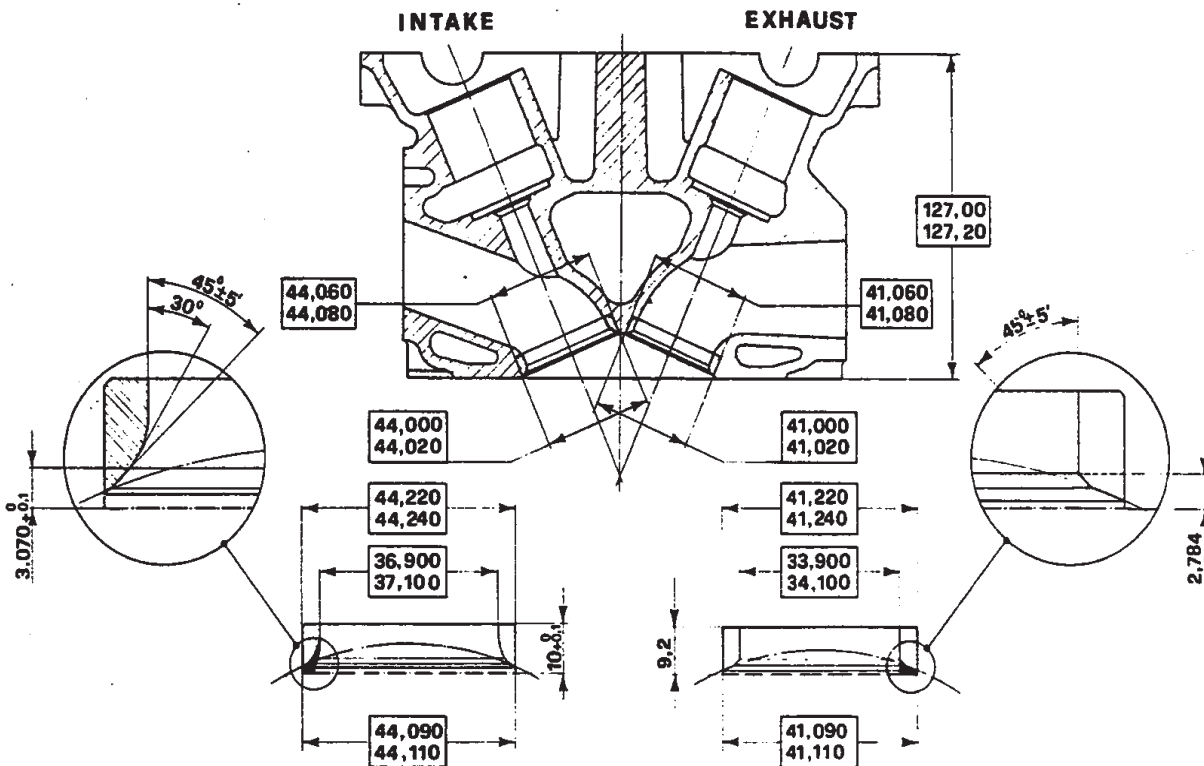

Fig. 10 - MAIN DATA of VALVE SEATS

CHECKING VALVE SPRINGS

Make sure that springs are neither cracked nor weak. Check the spring load with the suitable tester; compare the load and elastic deformation data found with those given for new spring that are shown in fig. 11.

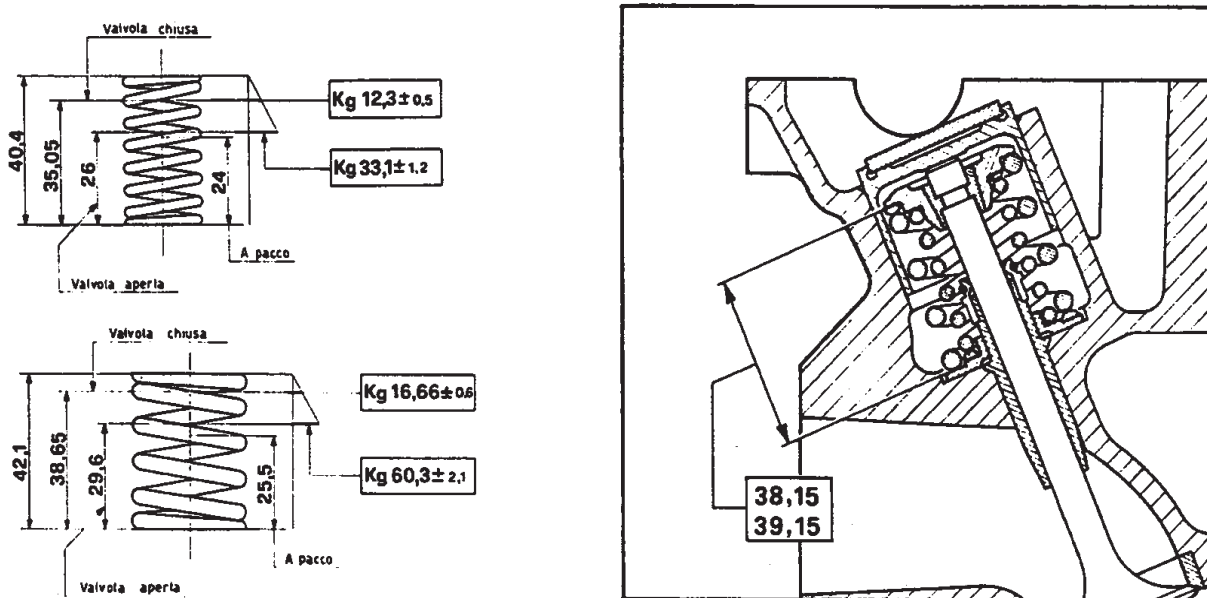

Fig. 11 - MAIN DATA of VALVE SPRINGS

Warning : Before assembling the springs, check that distance from lower face to face on upper shim is of $38,65$ mm. Should this distance exceed of $0,5$ mm. this value, make it correct by putting a steel washer of suitable thickness under the lower shim.

VALVE MECHANISM

MAIN SPECIFICATIONS	Page B 27
CAMSHAFTS	" B 27
CHECKING AND SETTING VALVE CLEARANCE	" B 28
REMOVING PADS	" B 28
TOOTHED BELTS FOR VALVE CONTROL	" B 29
ENGINE ASSEMBLING	" B 31

MAIN SPECIFICATIONS

DESCRIPTION	mm
Diameter of camshaft seats (with fitted cap)	24,990 + 25,010
Diameter of camshaft journals	24,937 + 24,950
Camshafts / seats coupling - assembling clearance	0,040 + 0,073
- limit of wear	0,10
Camshafts end float	0,050 + 0,169
Thickness of spacers varies from 3,25 to 4,60 mm. in steps of	0,05
Operating clearance (inlet)	0,20 + 0,25
(exhaust)	0,30 + 0,35
Timing clearance	0,50
Timing data	
INLET : opens before T.D.C.	34°
closes after B.D.C.	46°
EXHAUST : opens before B.D.C.	36°
closes after T.D.C.	38°
(inlet)	8,949
(exhaust)	8,323

CAMSHAFTS

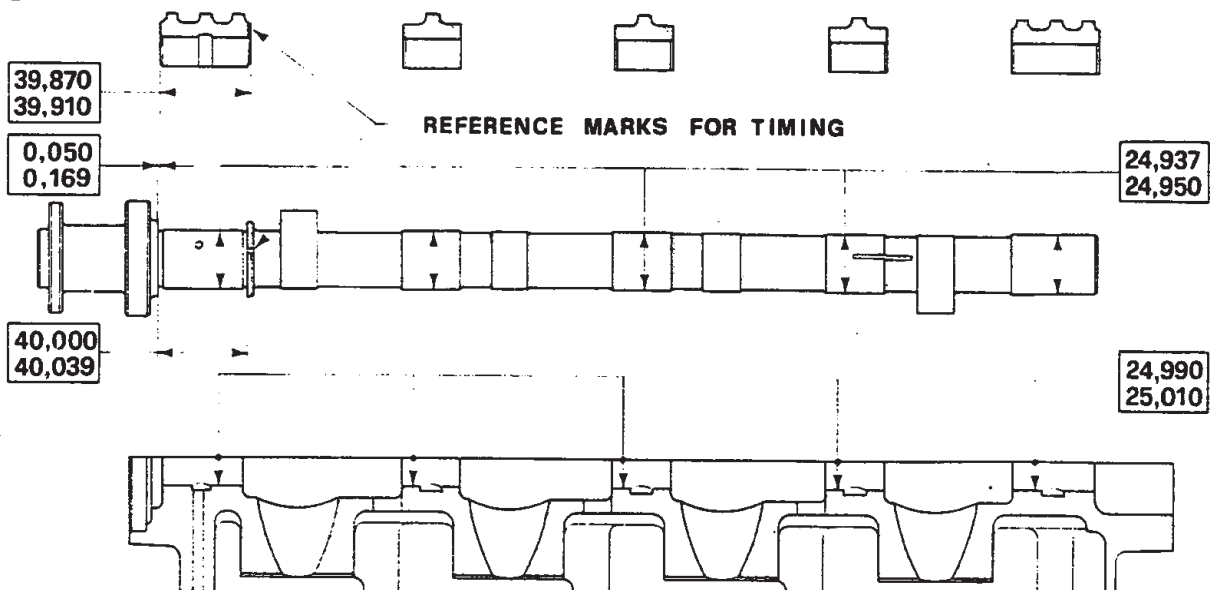

Fig. 12 - MAIN DATA of CAMSHAFTS

Each camshaft has an index, printed near the valve side support, that makes easier the valve timing.

With the engine to dead center 1/4 (cylinder n. 1 with the cams turned upwards) the marks of the 4 camshafts must correspond to those of the 4 covers.

CHECKING AND SETTING VALVE CLEARANCE

On each head the valves are inclined at 46° one with respect to the other and are actuated by an inverted thimble into which fits a spacer. The required valve clearance is achieved by selecting the proper spacer. The spacers vary in thickness from 3,25 mm. to 4,60 mm. in steps of 0,05 mm.

The thickness of the metal disc must not be reduced by grinding as the surfaces of the disc have a special hardening treatment.

With cold engine check the clearance between valves and camshafts; it must be:

- Inlet : 0,20 + 0,25 mm.
- Exhaust : 0,30 + 0,35 mm.

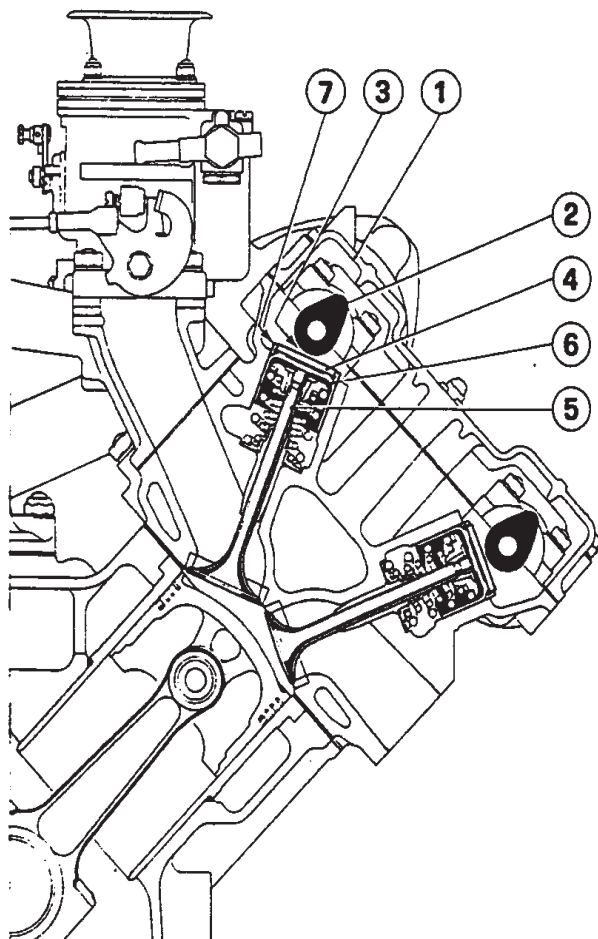

Fig.13 - ADJUSTING VALVE CLEARANCE.

1 - Camshaft cover; 2- Camshaft; 3- Clearance between tappet and cam; 4- Clearance adjustment shim; 5- Valve; 6- Thimble; 7- Thimble slot permitting clearance adjustment shim removal.

CLEARANCE ADJUSTMENT - REMOVING PADS

To adjust the clearance between cams and tappets, remove the spacers pushing downwards the cap using the tool 706-AS-9560.

Then insert the suitable spacer 2 which keeps the tappet lowered.

Once the tool 1 is taken away, blow with compressed air between thimble and spacer in order to withdraw the spacer.

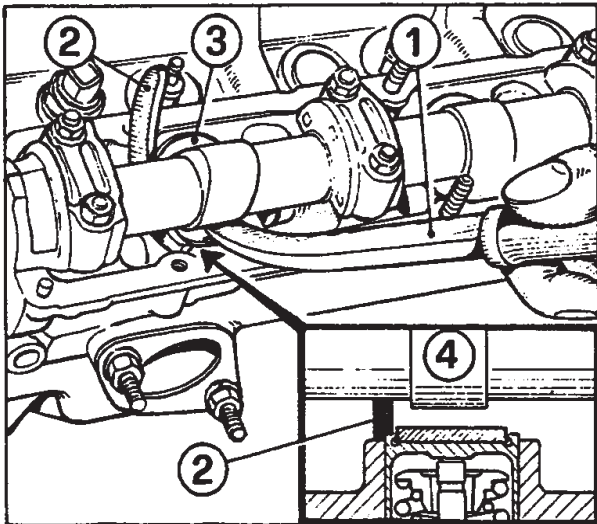

Fig. 14 - PADS REMOVING.
 1- Tool 706-AS-9560; 2- Spacer 706-AS-9560A; 3- Thimble; 4- Camshaft.

TOOTHED TIMING BELTS

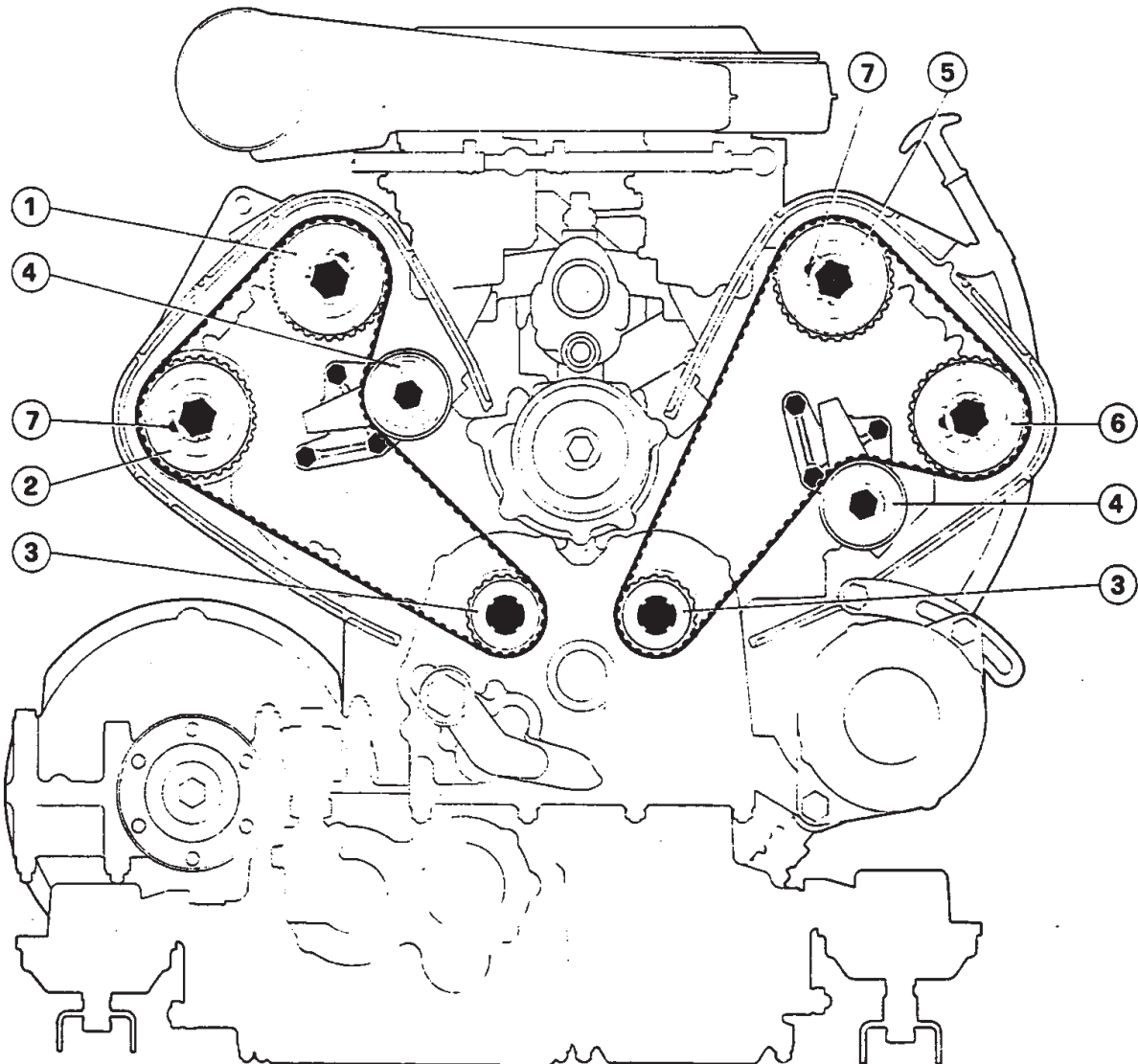

Fig. 15 - LAYOUT of CAMSHAFT DRIVE
 1- Inlet camshaft drive gear for cylinders 1-2-3-4; 2- Exhaust camshaft drive gear for cylinders 1-2-3-4; 3- Drive gears; 4- Idlers; 5- Inlet camshaft drive gear for cylinders 5-6-7-8; 6- Exhaust camshaft drive gear for cylinders 5-6-7-8; 7- Driving dowels.

The tension of the toothed timing belt must only be set when first installing it. Any further re-adjustment is useless since the working clearance will reappear unchanged after a short time, while the consequent elastic strain, increasing at each re-adjustment, could cause the belt breaking after a few operations.

Always replace the belt if it has to be removed in service.

- Every 15.000 + 20.000 km. check visually for belt wearing condition
- At 40.000 km. check carefully the belts then replace them in case of lack of efficiency.
- At 60.000 km. replace the belts.

EXACT BELT TENSION

For getting a correct belt tension adjustment when installing the belts, proceed as follows:

- Bring the engine to top dead centre (1-4).
- Loosen the idler blocking nuts A (in this way the spring will automatically apply the correct tension to the belts).
- Rotate the engine forwards of one turn only to bring it to top dead centre again (1-4).
- Tighten the idlers nuts A.

Warning

To prevent any belt damage during the assembly, carefully avoid to cause any offsetting of the belts.

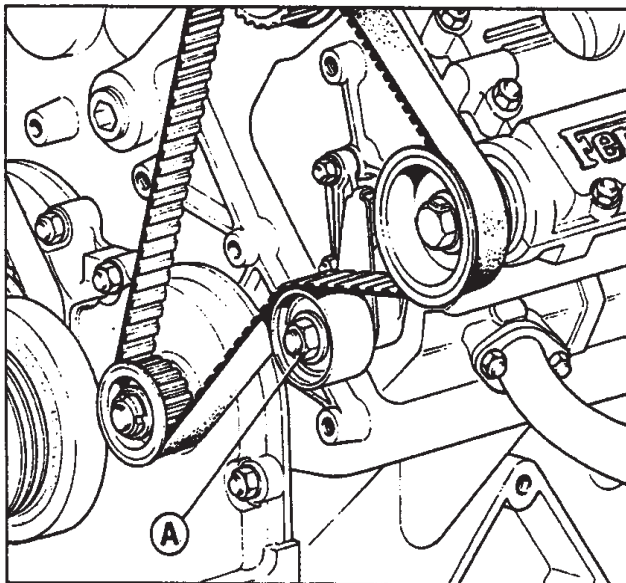

Fig. 16 - TIMING BELT IDLER

A - Adjusting nut.

Warning : The pulleys n. 102586 with inner edge (engine side) must be fitted to the right head exhaust shaft and to the left head inlet shaft.

The pulleys n. 102587 with outside edge, must be fitted to the right head inlet shaft and to the left head exhaust shaft.

ENGINE ASSEMBLING

Warning: When assembling the engine always replace all gaskets and seal rings.

1) Carefully clean all items with particular care for oilways, then put the engine block on stand AV 617.

Fit cylinder liners to crankcase and check that protrusion on heads face corresponds to the prescribed one. Withdraw cylinder liners then insert the proper rubber seals and definitely fit liners to crankcase. To avoid liners coming out, block them using the suitable 542-AS-6236 clamp.

- Overturn the crankcase and fit the main half-bearings on proper seats and lubricate with engine oil.
- Place the crankshaft and thrust half-rings on the crankcase then install caps with relevant half-rings following the numeration marked on crankcase surface.
- Tighten nuts to the prescribed torque shown in proper table (see page M 5).
- After all nuts have been tightened, the crankshaft should turn freely, without applying any effort and with suitable end float. (See page B 19).
- Introduce in crankshaft the timing and oil pump drive gear.
- Prepare the crankcase front cover assembling the relevant sealing rings, bearings, oil pump group (with drive gear) and the two timing gears with relevant pulleys. Introduce in crankcase the two bearings for timing gears then fit the cover on crankcase and grease the crankshaft oil retainers. When the cover is fixed, tighten the two ring nuts on the timing drive pulleys to the torque shown in page M 5. Use the wrench AV-815.
- Assemble the torsional damper and tighten the locking nut with AV-476 wrench to prescribed torque.

2) Assemble each connecting rod to proper piston (see page B 16 - fig. 6), install new piston and scraper rings taking care to place the free ends of rings approximately 90° apart. Fit the half-rings to proper seats.

The replacement of piston rings is advisable after each overhauling operation, even if their tolerances are within the specified limits, in order to avoid a long adapting period.

Warning : The connecting rods must be of the same class, i.e. they must be marked with the same letter which classify their weight. The eventual difference in weight should not exceed 2 grams.

Introduce piston/connecting rod group into the proper cylinder liners observing the reference marks. Lubricate connecting rod pins and bearings. Tighten each connecting rod bolt to the prescribed torque. Make sure that they turn freely on their pins and that the total end clearance is 0,20 + 0,34 mm.

3) Place carefully the two head gaskets on the engine block and avoid to spread the surfaces with any substance.

Introduce the heads, prepared beforehand, into studs and tighten the nuts to the recommended torques following the order shown in fig. 17. Use the wrench AV-498.

- Assemble intake manifolds and water outlet manifold using a light layer of paste CAF 1 or CAF 4.
- Proceed with checking the water sealing: for this close the water lines and introduce possibly warm water through the heads manifold at the pressure of 8 + 10 kg/cm². Make sure that there are no leaks from liners rubber seals. If the pressure keeps constant for approximately 5 + 10' the sealing is considered in order.

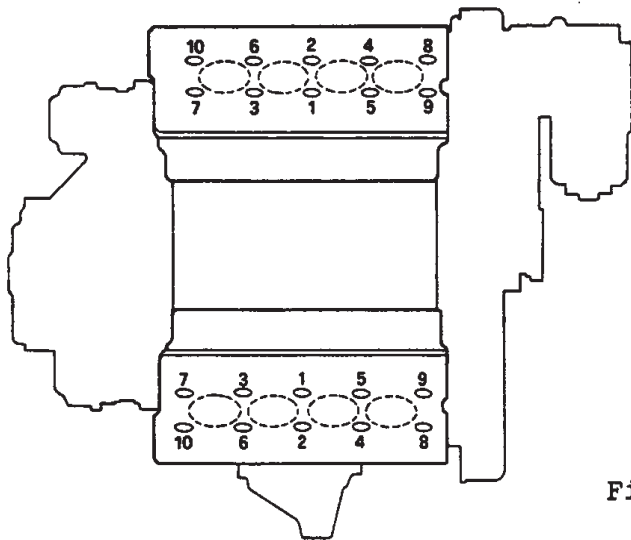

Fig. 17 - DIAGRAM of CYLINDER HEADS NUTS TIGHTENING ORDER

- Turn the crankshaft up to cylinder n. 1 T.D.C. Block the shaft in this position and assembly the 4 camshafts; take care that the reference marks on the 4 supports on distribution side match exactly with the marks on the camshafts. Introduce the 4 oil retainers previously greased.
- Fit the two belt stretchers to heads and introduce the pulleys in the crankshafts without blocking them with the dowels. Introduce the timing belts and research the correct pulleys orientation, then lock them with dowels.
- With the engine to T.D.C. loosen the belt stretchers; in this way the correct belts tension is automatically applied. Slightly rotate forwards the crankshaft, make sure of correct camshafts position, rotate the crankshaft of one turn and tighten the stretchers nuts. Bring again the cylinder n. 1 to T.D.C. (upward position) and check by graduated flywheel that timing angular values correspond to those shown in figure.

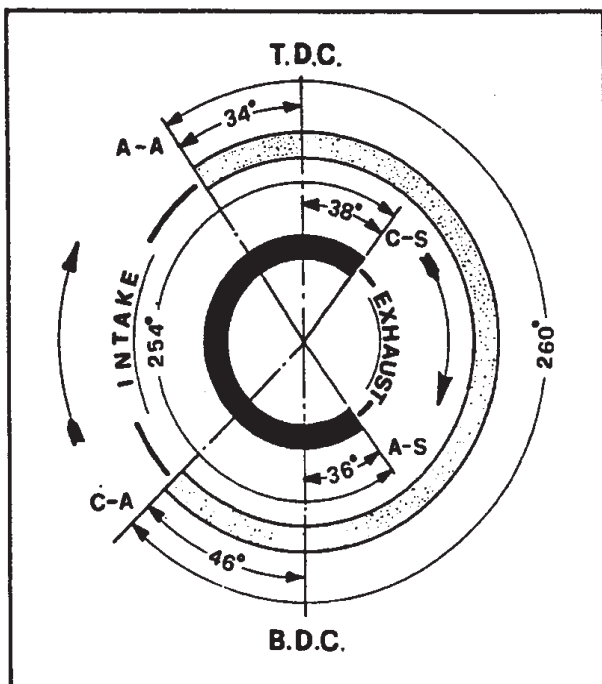

Fig. 18 - TIMING CHECKING DIAGRAM

VALVE TIMING CLEARANCE	
Intake	mm. 0,50
Exhaust	mm. 0,50

Intake	Opens before T.D.C.	34°
	Closes after B.D.C.	46°
Exhaust	Opens before T.D.C.	36°
	Closes after B.D.C.	38°

OPERATING CLEARANCE	
Intake	mm. 0,20+0,25
Exhaust	mm. 0,30+0,35

- Lock the pulleys bolts to prescribed torque and bend the locking plates.
Lubricate all engine components using pressure pump and make sure that the oil reaches all cams and bearings.
- Using a thickness gauge, check the clearance between shim and cam of each valve and, if necessary, bring it to the prescribed value.

Warning : In order to avoid this operation, the pads thickness can be predetermined during heads assembling using the suitable gauge 152-CS-7148 instead of the camshafts.

Set the dial gauge to zero putting it on plaque 152-AS-7149.

Fit the thimbles to valves with proper pads, put the gauge in camshafts housings and check the clearance between pads and gauge; if necessary, replace the pads to reset the exact clearance.

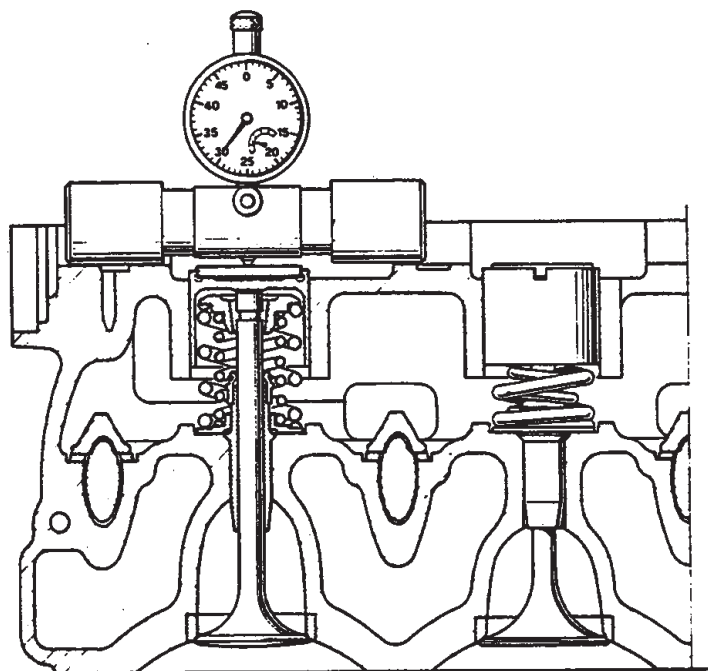
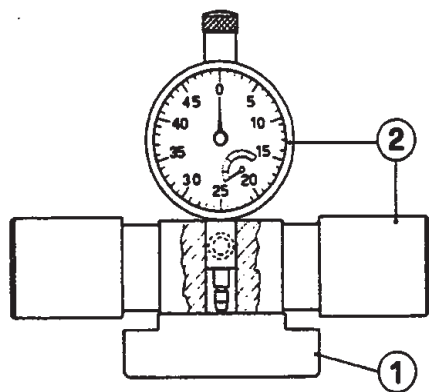

Fig. 19 - ZERO SETTING OF DIAL GAUGE

Fig. 20 - VALVE CLEARANCE

1 - Plaque 152-AS-7149

2 - Gauge 152-CS-7148

4) Assemble the water pump unit with relevant pipes after checking of bearings and replacement of seal ring.
Fit carburettors and relevant linkage.
Fit valve caps to heads, assemble the timing case and side caps; then overturn the engine and fit the protective plate and oil pump intake pipe spreading the gasket with a light layer of Hylomar paste.
Join the engine to gearbox, assemble the casing between engine block and clutch bell, oil ring and flywheel.

Warning : When the engine needs a bench-test, connect it to gearbox since this will act as a support, and oil sump but without clutch.
Fit the distributors to the engine and carry out the ignition timing.

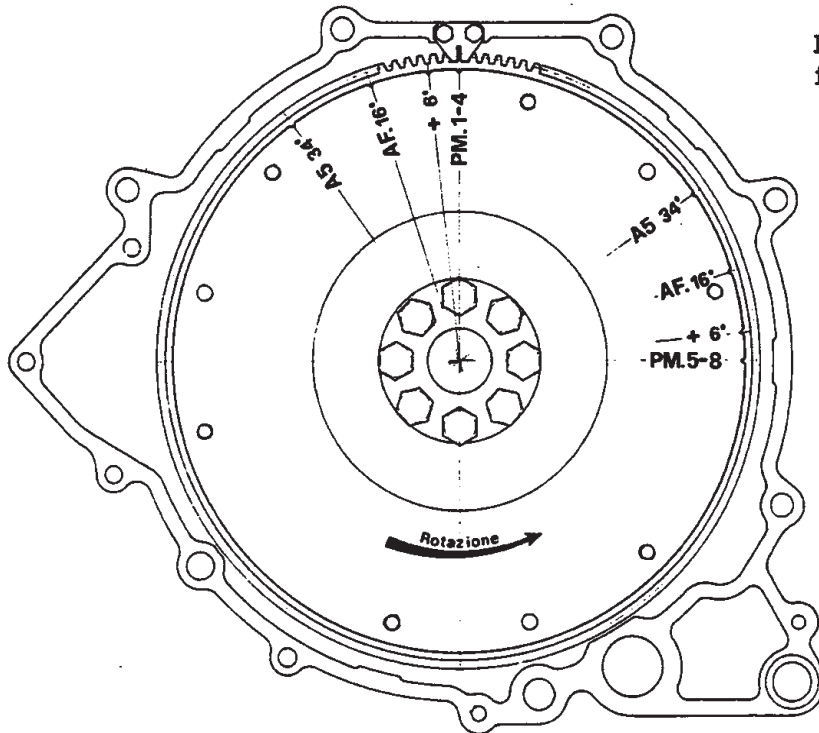
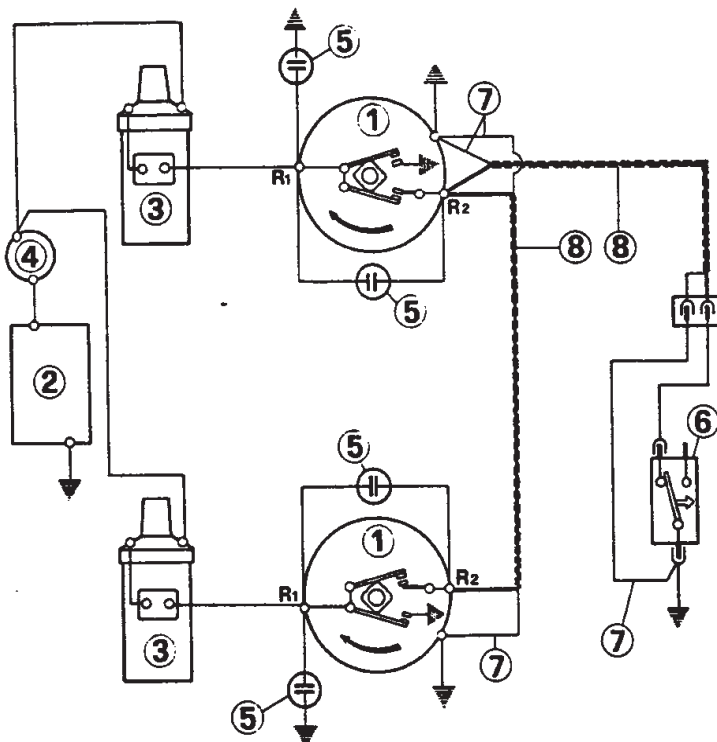

Fig. 21 - FLYWHEEL MARKS
for IGNITION CHECKING

To achieve ignition timing, follow the subsequent instructions:

- Make sure that distributors adjustment corresponds to prescriptions of "Ignition Timing" - see page L 10.
- Turn the crankshaft in the working direction until reference mark $+6^\circ$ on the flywheel corresponding to cylinder bank 1/4 will line up with the fixed index on the clutch bell and cylinder 1 is in compression stroke. (Warning: do not turn the crankshaft in the opposite direction to avoid the loosening of timing belts).
- Turn the distributor shaft until the rotor arm lines up with cylinder 1.
- Fit the distributor with stud bolts approximately to the middle of the slot but do not tighten completely the fixing nuts.
- Repeat these operations for cylinder bank 5/8 observing the relevant mark $+6^\circ$.
- Connect the stroboscopic lamp to cylinder 1 and with engine to idle (800 + 1000 RPM) make sure that the static advance is 6° B.T.D.C.
- Still with lamp connected to cylinder 1 lightly accelerate acting on the accelerator pedal so that the microswitch, connected to it, opens the circuit and insulates the retarded breaker point R2 (1100 ÷ 1200 RPM).

The ignition impulse is generated by breaker points R1 or R2 according to the position of the microswitch (6) operated by accelerator pedal. At idle R2 is earthed and the ignition is retarded.



A light movement of accelerator opens the microswitch (6) breaker points thus isolating R2. In this way the ignition impulse is generated by R1 with a further advance of 10° on the engine.

Fig.22 - DIAGRAM of DISTRIBUTOR ELECTRIC CONNECTION.

1 - Distributors; 2- Battery
3- Coils; 4- Switch; 5- Condensers;
6- Microswitch operated by accelerator pedal;
7- Earth for radio noise suppressor screening;
8- Screened unipolar cable.

- In this condition make sure that the lamp lights when the fixed index lines up with mark AF 16° on the flywheel. If this will not happen, even with the coincidence at idle (R2 to earth) with the index $+6^\circ$, this means that the advance of R1 in relation to R2 is incorrect and needs to be reset with the distributor on a test-bench.
- If both the coincidences $+6^\circ$ and AF 16° are verified, accelerate with the pedal making the engine run up to 5000 RPM. In this condition the stroboscopic lamp should illuminate the A5/ 34° point which corresponds to the advance of 34° at 5000 RPM. Otherwise it is necessary to bench test the advance curve.

Warning : Do not fully accelerate operating directly the carburettor control rod since this could damage the engine as it would operate with the R2 retarded breaker point also at high RPM.

- Effect the same procedure for the distributor of cylinder bank 5/8.

Warning : The index AF 18° is printed on the early flywheels; therefore it is necessary to move 3 + 4 mm. towards the top dead center on the flywheel outside diameter to verify the advance at 16° .

ENGINE BENCH TEST AND RUNNING-IN

Once the reassembling is completed, put the engine on a test-bench in order to run-in all working surfaces, to effect all tuning operations and to check the power, the fuel and the lubricants consumptions.

These are the instructions to follow:

- Set oil level in sump.
- Effect the motoring over at 1500 RPM for approx. 5' to check oil and water circulation and possible leaks.
- Make the engine run at 2300 RPM for 40 minutes with a load of 14 kg. (32 HP).

- Repeat this test for 40 minutes at 4000 RPM with a load of 16,5 kg. (66 HP).
- Check and adjust ignition advance to 34° at 5000 RPM.
- Effect another test of 40 minutes at 5700 RPM with a load of 20,5 kg. (117 HP); toward the end of the test bring the oil temperature at 110°C and check that pressure is $5,5 + 6,5 \text{ kg/cm}^2$.
Stop the engine and after 5 minutes measure with a dipstick the oil level in the sump. Carefully reset the level.
- Bring the engine again at 5700 RPM with a load of 20,5 kg. (117 HP) and carry out one hour test, without interruption, keeping the oil temperature at 110°C .
With the engine steady and after 5 minutes, exactly reset the level measuring the quantity of oil introduced.
The average consumption of one hour is $0,150 + 0,250 \text{ kg}$. equivalent to $1,30 + 2,00 \text{ grams per HP/h}$.
- Check the power curve every 1000 RPM with fully open accelerator and starting from 2000 RPM to 7500 RPM; check the fuel consumption at 5000 RPM. The standard values are 210 grams per HP/h at 5000 RPM and 230 grams per HP/h at 7000 RPM.
Without varying the brake adjustment for 7000 RPM, gradually close the accelerator until the engine runs at 5000 RPM then check again for fuel consumption. The average value is 230 grams per HP/h.
- Carry out carburetors synchronization using a motometer and without removing the exhaust pipes.
- Effect a general checking of engine for possible outside leaks.
- With cold engine remove the valve covers, tighten the heads and check valves clearance.

SECTION **C**

LUBRICATION
COOLING
FUEL SYSTEM

	Page
LUBRICATION	C 3
MAIN SPECIFICATIONS	C 3
OIL PUMP	C 5
CRANKCASE EMISSION CONTROL SYSTEM	C 6
COOLING	C 7
MAIN SPECIFICATIONS	C 7
WATER PUMP	C 8
RADIATOR	C 10
EXPANSION TANK	C 10
THERMOSTATIC VALVE	C 10
ELECTRIC FANS	C 11
FUEL SYSTEM	C 13
FILTER AND AIR INTAKE	C 13
FUEL PUMP	C 13
CARBURETTORS	C 14
CARBURETTOR SETTING DATA	C 19
CARBURETTOR SYNCHRONIZATION AND ADJUSTMENT	C 20

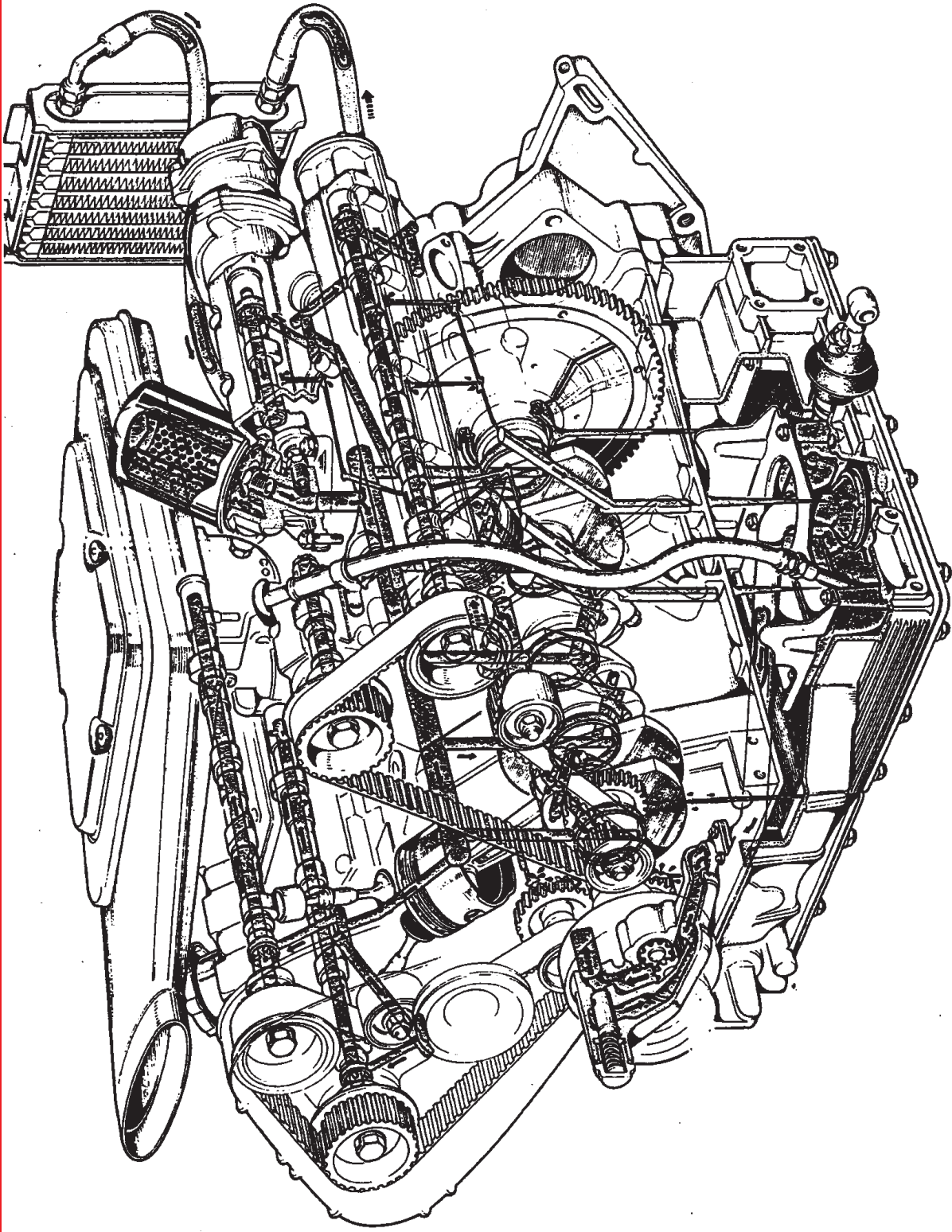

Fig. 1 - ENGINE LUBRICATION DIAGRAM

LUBRICATION

MAIN DATA OF OIL PUMP	Page C 3
GENERAL INFORMATION	" C 4
PRESSURE AND TEMPERATURE	" C 4
OIL CHECKING AND REPLACEMENT	" C 4
PRECAUTIONS FOR USE OF DIFFERENT OIL BRANDS	" C 4
OIL PUMP	" C 5
CLEANING AND CHECKING	" C 5
CRANKCASE EMISSION CONTROL SYSTEM	" C 6

MAIN DATA OF OIL PUMP

DESCRIPTION	mm
Outside diameter of driving and driven gear	35,975 + 35,991
Diameter of gear seat on pump casing	36,075 + 36,100
Opening between gears outside diameter and pump casing	0,042 + 0,062
Height of driving and driven gear	32,959 + 32,980
Depth of pump casing	33,070 + 33,100
Mounting end float	0,090 + 0,141
Clearance between gear-teeth	0,2
Inside diameter of bushing on driven gear	12,027 + 12,050
Diameter of driven gear shaft	12,007 + 12,018
Radial play between driven gear and shaft	0,009 + 0,043
Diameter of bushing seat in driven gear	15,000 + 15,018
Outside diameter of bushing	15,021 + 15,036
Mounting interference between bushing and gear	0,003 + 0,036
Diameter of driving gear pins	14,976 + 14,994
Inside diameter of bushing for driving gear (set)	15,015 + 15,027
Assembling radial play	0,021 + 0,051
- limit of wear	0,08
Outside diameter of bushing	18,018 + 18,036
Diameter of bushing seat on pump casing	18,000 + 18,018
Mounting interference	0,000 + 0,036
Mesh clearance of control gear on crankshaft	0,04 + 0,06

GENERAL INFORMATION

The engine is pressure lubricated by a gears pump which is fitted to the crankcase front cover and is driven by the crankshaft through gears.

The lubrication system includes also:

- Intake pipe provided with a filtering net, fixed to oil sump.
- One full-flow filter fixed to the crankcase rear side.
- Pressure relief valve.
- Oil radiator with proper air conveyor-double position "Summer and Winter".
- One electric transmitter for oil pressure.
- One electric transmitter for oil temperature.

PRESSURE AND TEMPERATURE

In normal running conditions the oil pressure should be within 5,5 and 6,5 kg/cm² with the engine running at 6000 RPM and oil temperature of 100° C.

Warning : If, with the engine running at the same speed and temperature, the pressure is less than 4,5 kg/cm², the engine revs should be reduced of 1000 RPM at least and the reason for the low oil pressure established.

It is necessary to reduce the engine RPM in case the temperature exceeds 130° C.

OIL CHECKING AND REPLACEMENT

Every 500 km. check oil level. Effect this operation with warm engine just after its stopping thus avoiding that radiator oil discharges into the sump.

Every 5000 km. or every 6 months at most, replace the oil and filters. Filters replacement can even be effected at 10000 km.

PRECAUTIONS FOR USE OF DIFFERENT OIL BRANDS

Should for any reason other brands of oil be used the following procedure is recommended.

- Thoroughly drain the oil from sump when hot.
- Fill the sump with 7 litres of the oil to be used warming it by making the engine run at 2000+3000 RPM for 10' + 15'.
- Fill up to maximum level with the new oil having the recommended rating. Every 5000 km. change oil and filter.

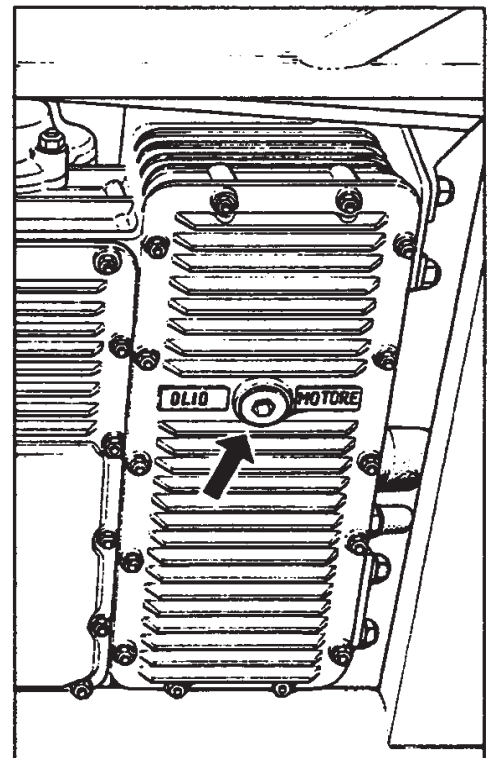

Fig. 2 - ENGINE OIL DRAIN PLUG

OIL PUMP

CLEANING AND CHECKING

- Carefully check pump body and cover: should any cracking be noticed, replace.
- Check that oilways are not obstructed; blow them with a strong air compressed jet to ensure a perfect cleaning.
- Examine driving and driven gears: replace them in case of excessive wear or deterioration.
- The backlash of the gears is of 0,2 mm.; the maximum acceptable wear is 0,25+0,30 mm.: it is necessary to replace the gears if this limit is exceeded.
- Check the clearance existing between gear ends and relevant seats on pump casing using a feeler gauge: assembling clearance is of 0,042 + 0,062 mm.
- Check that the clearance between the upper face of the gears and the pump cover seating face is mm. 0,09+0,141. If this clearance exceeds 0,15 mm., replace the worn items.
- Check the bushes of driving gears on pump casing and cover; check also the bushes inside the driven gear.
- Check the two gears shafts: should any seizing signs be noticed, replace them.

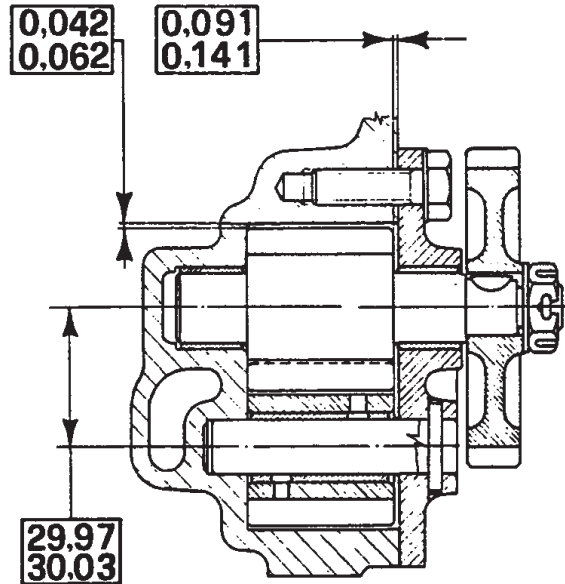

Fig. 3 - SECTION of OIL PUMP

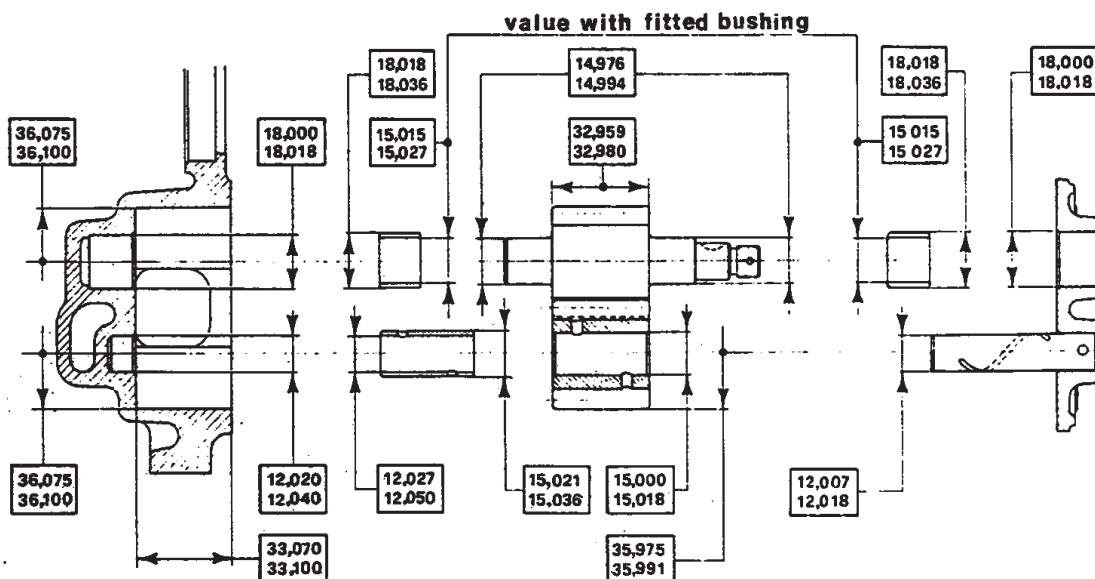

Fig. 4 - MAIN DATA for CHECKING CLEARANCE of OIL PUMP COMPONENTS

CRANKCASE EMISSION CONTROL SYSTEM

The crankcase emission control system is closed.
The oil vapors from the engine heads pass through a drops separator and are sucked by engine through air intake and carburetors.
There is a flame arrestor in the pipe going to air intake.
Every 20.000 km. clean the system including flame arrestor. Check also all lines for satisfactory conditions.

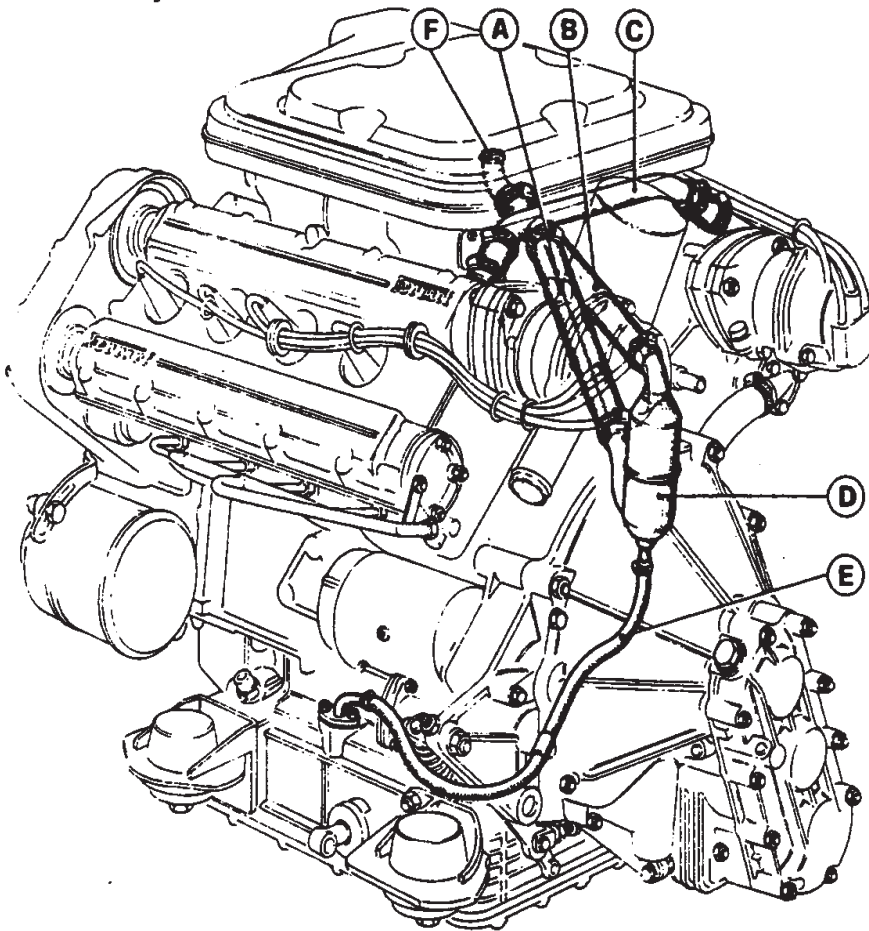

Fig. 5 - CRANKCASE EMISSION CONTROL SYSTEM

A - Vapor pipe to drop separator; B - Vapors pipe to air intake;
C - Vapors exhaust pipe from cylinder heads; D - Oil drop vapors separator; E - Oil drain tube from separator to sump; F - Flame arrestor.

C O O L I N G

MAIN SPECIFICATIONS Page C 7
 GENERAL INFORMATION " C 7
 WATER PUMP " C 8
 CLEANING AND CHECKING " C 9
 BELT TENSION ADJUSTMENT " C 9
 RADIATOR " C 9
 EXPANSION TANK " C10
 THERMOSTATIC VALVE " C10
 FILLING THE COOLING SYSTEM " C10
 ELECTRIC FANS " C11
 INSTRUCTIONS FOR WINTER TIME " C11

MAIN SPECIFICATIONS

DESCRIPTION		DATA
Maximum pressure	kg/cm2	0,9
Maximum temperature		115° C
Working range of radiator electric fans		85 + 76° C
Opening of thermostatic valve		80 + 85° C
WATER PUMP		
Diameter of rotor	mm.	69,80+69,90
Clearance between rotor blades and front cover	mm.	1,00+1,20
Clearance between rotor and pump casing	mm.	0,90+1,10

GENERAL INFORMATION

The engine cooling takes place through water and antifreeze mixture circulation. This circulates by a centrifugal pump driven by the crankshaft with a triangular belt.

The cooling system consists of the following components:

- Horizontal flow radiator.
- Supplementary expansion tank with plug(having a calibrated valve 0,9 kg/cm2) through which the filling is effected.
- Two electric four bladed fans fitted in front of the radiator.
- Thermostatic valve fitted in the water outlet manifold.
- Temperature transmitter unit.

The radiator is fitted, at its highest point, with an airbleed valve for use when filling the cooling system or when bad circulation problems arise.

If during engine operating water temperature reaches high values, check first of all the thermostatic valve; should this be in standard conditions, the excessive heating could be due to a faulty thermostatic switch or to the electric fans in front of radiator or to water pump faulty operating.

Overheating can also be produced by water leaks from radiator or from water pump or from heaters inside the car.

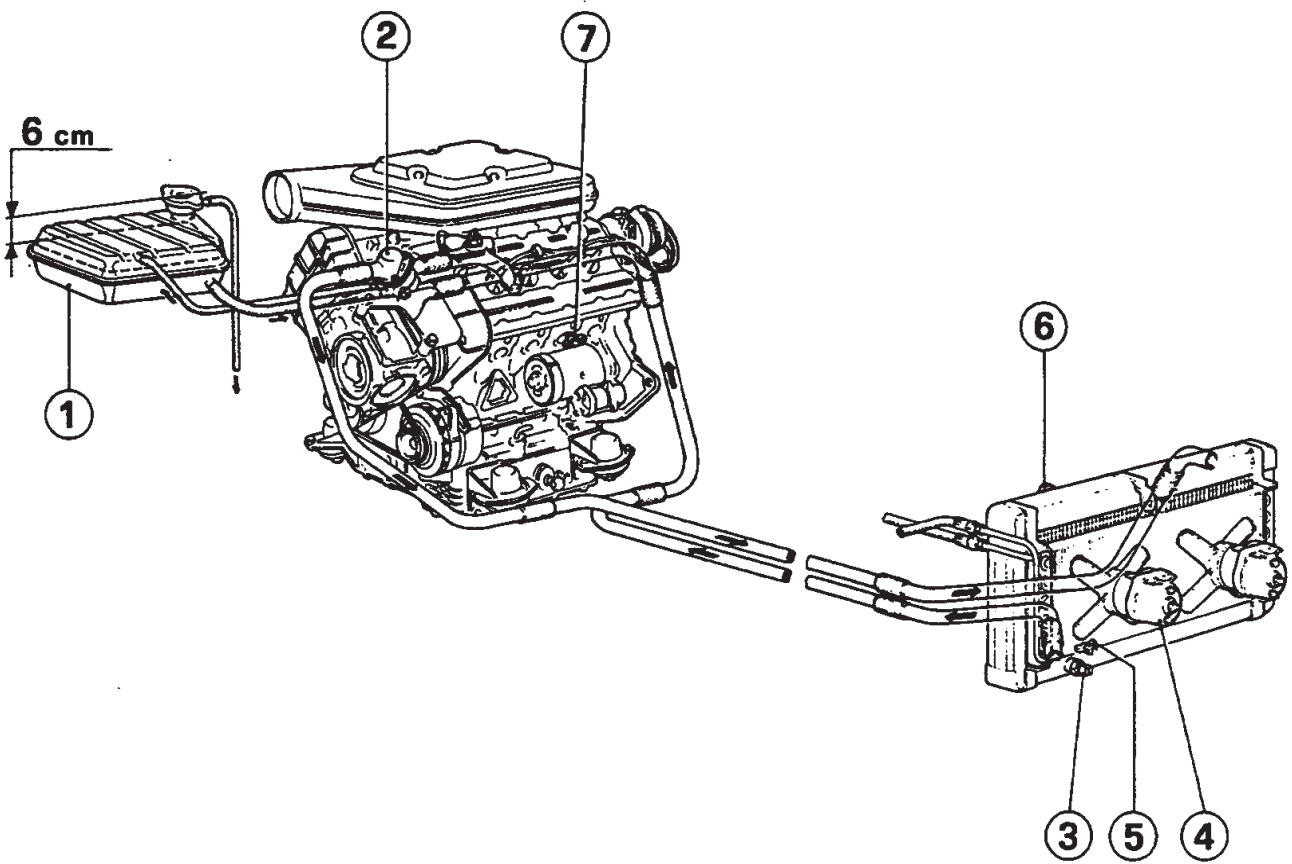

Fig. 6 - COOLING SYSTEM DIAGRAM

1 - Expansion tank; 2 - Thermostatic valve; 3 - Temperature sensitive switch; 4 - Electric fan motors; 5 - Water drain tap; 6 - Air-bleed valve; 7 - Water drain tap from the crankcase.

WATER PUMP

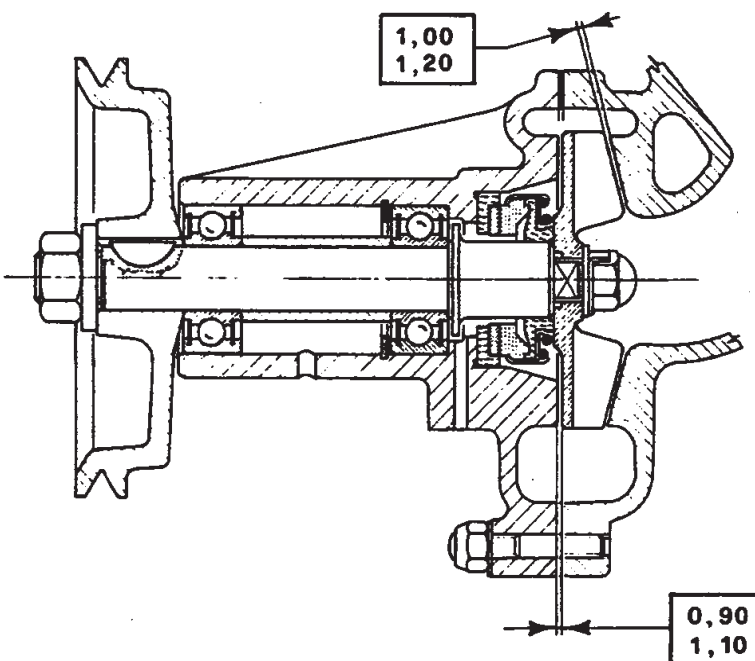

Fig. 7 - SECTION of WATER PUMP.

CLEANING AND CHECKING

- Remove calcareous fouling from pump casing and cover, check that all parts do not show wear or seizing signs.
- Check that pump rotor does not show clearance; check its perpendicularity in relation to shaft axis and make sure that blades are not dented.
- Check bearings noise in rotation plus axial and radial play.
- It is advisable to replace seal rings to each engine overhaul operation and also when they are removed from their seats.
- Check conditions of rubber ring for pump cover water seal then blow the exhaust hole.
- Make sure that bearings do not show clearance neither on the shaft nor in their seats on pump casing.

WATER PUMP AND ALTERNATOR BELT

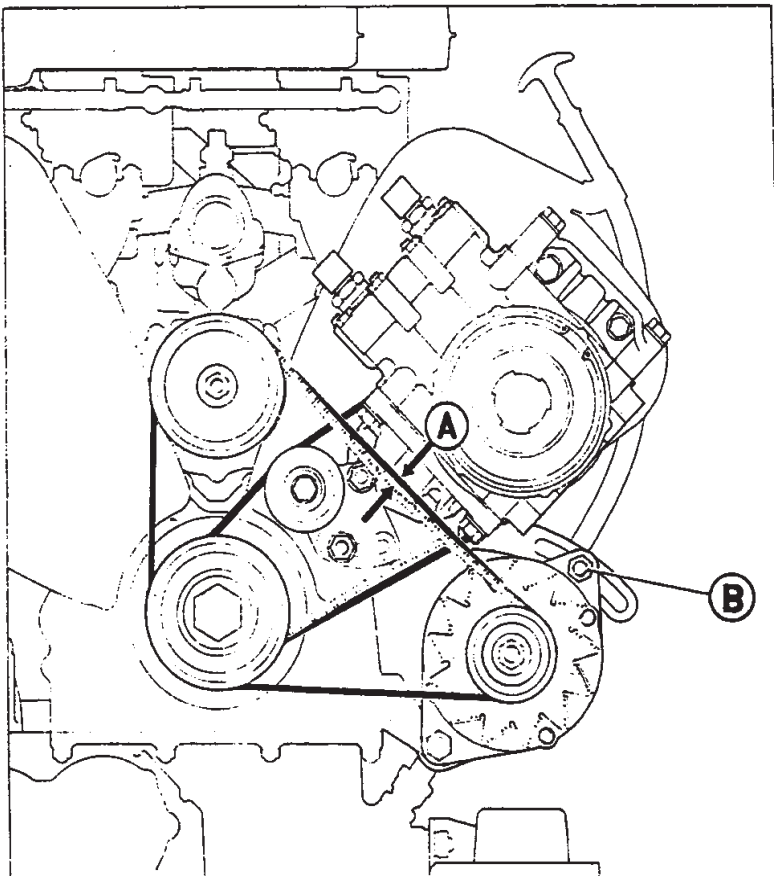

Fig. 8 - BELT TENSION

BELT TENSION (Check with cold engine).

MANUAL TENSIONING

The deflection of the belt in the middle of the two pulleys must be 4,6 mm. with a load of 1,5 + 2,2 kg.

TENSIONING BY TENSIO METER B

The tension of a new belt should be 34 kg. read on scale 7M of tensiometer B "Gates 150 type".

With used belt the charge should be 28 + 34 kg.

To increase the belt tension, slacken the nut A on the adjusting bracket, move the alternator downwards and re-tighten the nut.

RADIATOR

The radiator, horizontal flow type, is equipped with an airbleed valve for use when filling the cooling system or when bad circulation problems arise.

In the lower part of the radiator there is fitted a temperature sensitive switch for the automatic connection of the electric fans when temperature reaches 84°C and it disconnects fans when temperature is below 75°C .

Warning : It is absolutely recommended to avoid the application to the front of the car of any accessory which may restrict in any way the air intake to the radiator.

EXPANSION TANK

The tank takes care of changes in volume and pressure of the mixture occurring during engine heating; this supplementary tank is equipped with a pressure cap set to kg/cm^2 0,9, through which the cooling system is filled.

THERMOSTATIC VALVE

The thermostatic valve is placed on the water outlet manifold. It must be checked every year to ensure its regular operating.

Warning : It is not possible to eliminate the thermostatic valve as the circulation would mainly take place through the by-pass thus excluding the radiator.

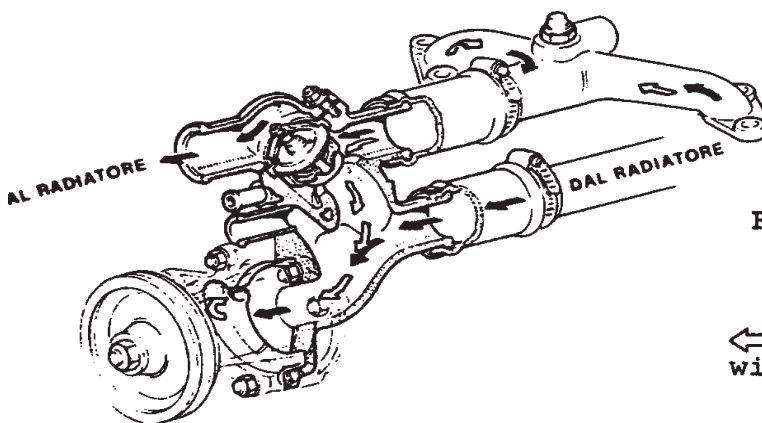

Fig. 9 - THERMOSTATIC VALVE

← Cooling water circulation with closed thermostatic valve.

← Cooling water circulation with opened thermostatic valve.

FILLING THE COOLING SYSTEM

The cooling system is filled through the expansion tank. During this operation, keep the airbleed valve opened: it is fitted to radiator top point.

Afterwards, carefully bleed the system with warm engine and open thermostatic valve.

ELECTRIC FANS

In front of the radiator there are two electric fans for cooling the radiator and the air conditioner condenser.

When connecting the air conditioner, also the right fan gets on and it remains on even when conditioner stops operating if water temperature in radiator exceeds 84° C.

INSTRUCTIONS FOR WINTER TIME

When the ambient temperature is near 0° C, the antifreeze mixture must be checked and the quantities shown in relevant table must be observed.

Serious damages can occur in case these instructions are not followed.

TEMPERATURE	QUANTITY in LITRES
- 15° C (+ 5° F)	5,7
- 30° C (- 22° F)	7

FUEL SYSTEM

FILTER AND AIR INTAKE	Page C 13
CLEANING AND CHANGING FILTER	" C 13
FUEL PUMP AND FILTERS	" C 13
CARBURETTORS WEBER 40 DCF 35/36/37/38	" C 14
TROUBLE DIAGNOSIS AND REMEDIES	" C 15
OPERATING INFORMATION	" C 17
SETTING DATA	" C 19
SYNCHRONIZATION AND ADJUSTMENT	" C 20

FILTER AND AIR INTAKE

The engine is equipped with an air intake and proper filter, into which the intake trumpets of the 4 carburettors are fitted. Always make sure of the perfect seal of air intake cover on the filtering element.

CLEANING AND REPLACING THE FILTER

For a good engine efficiency it is necessary that the air intake filtering element is often removed for cleaning. Every 10000 km. at the most remove and carefully clean the filter; replace it at least every 20000 km.

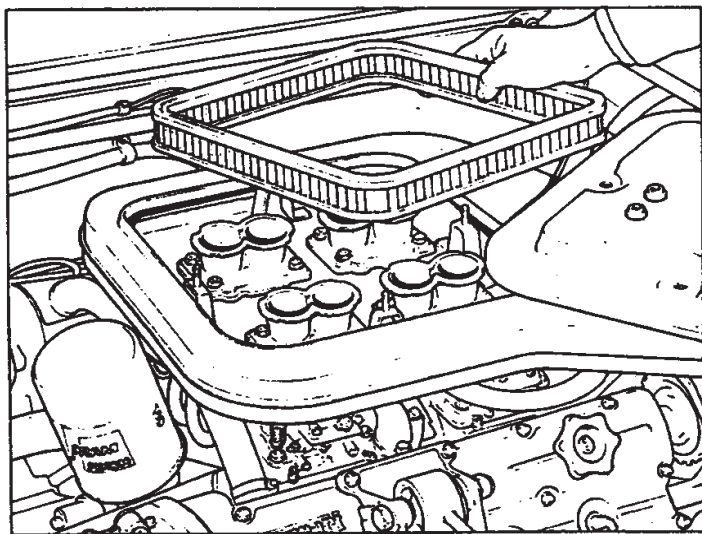

Fig. 10 - AIR INTAKE and FILTER.

FUEL PUMP AND FILTERS

MAIN DATA OF FUEL PUMP

DESCRIPTION		DATA
Tension	Volt	12
Electrical input	Amp.	1,5 ± 0,2
Capacity	litres/hr	100
Pressure	m.H ₂ O	3 ± 0,5
Calibrated hole for fuel relief	mm.	1,5

The pump feeding the carburettors is a CORONA type and is placed in the left rear side of the car.

There are also two filters fitted in the fuel system: one on the intake connection from tanks and the other, FISPA type with removable filter element is upstream of pump.

Other filters are placed on the carburettor fuel connections.

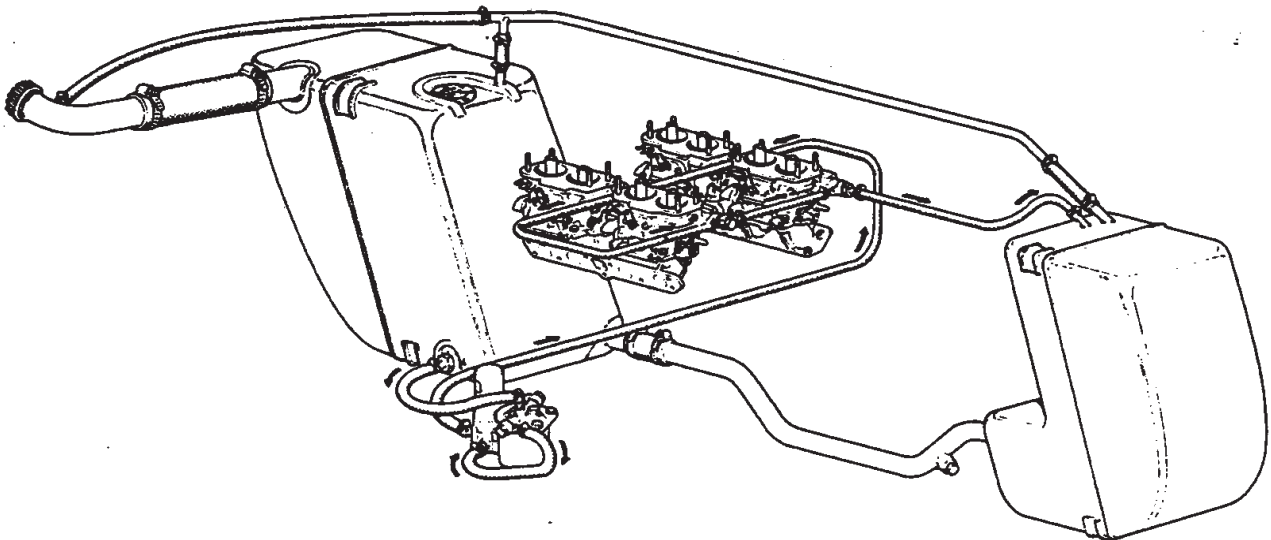

Fig. 11 - DIAGRAM of FUEL SYSTEM

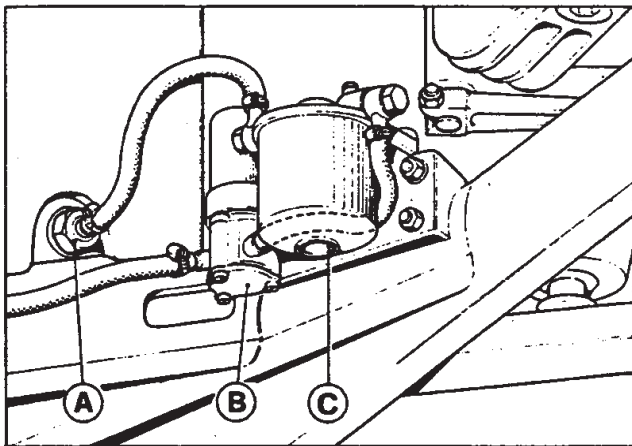
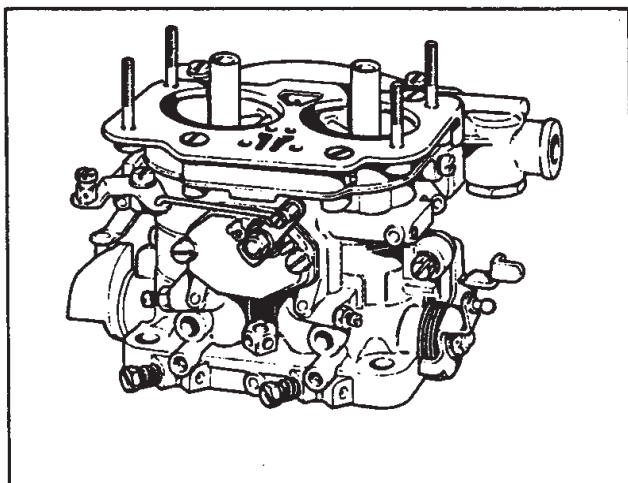

Fig. 12 - FUEL PUMP and FILTERS

CARBURETTORS WEBER 40 DCF 35/36/37/38



The engine is fed by four/double chokes carburettors equipped with a starting device for cold engine start (hand controlled) and with diaphragm type accelerator pump.

Fig. 13 - CARBURETTOR

CARBURETTORS TROUBLE DIAGNOSIS AND REMEDIES

ENGINE DOES NOT START WHEN HOT

POSSIBLE CAUSES	REMEDIES
<ol style="list-style-type: none"> 1) Idling device incorrectly set. 2) Engine overheated, causing rapid evaporation of fuel bowl, the vapour filling the ducts. 	<ol style="list-style-type: none"> 1) Readjust idling device. 2) Operate starter with accelerator pedal fully pressed.

ENGINE DOES NOT START WHEN COLD

POSSIBLE CAUSES	REMEDIES
<ol style="list-style-type: none"> 1) Obstructed starting jets. 2) Fuel does not arrive. 	<ol style="list-style-type: none"> 1) Remove and clean jets. 2) Check operating of pump, filters and fuel in tanks.

IRREGULAR RUNNING at IDLING SPEED

POSSIBLE CAUSES	REMEDIES
<ol style="list-style-type: none"> 1) Air leak through gaskets between carburettor and intake manifold. 2) Obstructed or slow idle jets 3) Throttle valves not returning to idle position due to pin hardening or due to clearance in control joints. 	<ol style="list-style-type: none"> 1) Tighten carburettor fixing nuts and check, if necessary, that the carburettor flange is not deformed. 2) Remove and blow jets and ducts. 3) Check accelerator linkage. Make sure that throttle valve shaft can turn freely.

FLOODING and FUEL LEAKAGES

POSSIBLE CAUSES	REMEDIES
<ol style="list-style-type: none"> 1) Incorrect seal of some needle valves due to dirt or wear. 2) Faulty float (dented or punctured). 3) Incorrect fuel level. 4) Seizing or friction preventing float regular movement. 5) Abnormal fuel pump pressure. 	<ol style="list-style-type: none"> 1) Check that there is no dirt between valve seat and needle. If there is none, change valve. 2) Change float. 3) Reset correct level as explained on page C 19. 4) Check. 5) Check pressure.

BAD PICKUP and POOR SPEED PERFORMANCE

POSSIBLE CAUSES	REMEDIES
<ol style="list-style-type: none"> 1) Incorrect fuel level. 2) Incorrect synchronization of carburettor controls. 	<ol style="list-style-type: none"> 1) Reset correct level as explained on page C 19. 2) Check synchronization using the suitable gauge.

BAD PICKUP and POOR SPEED PERFORMANCE (continuation)

POSSIBLE CAUSES	REMEDIES
3) Incorrect adjustment of carburation with partially opened throttles.	3) Check and adjust.
4) Incomplete throttles opening with fully open accelerator.	4) Check.
5) Obstructed fuel filters (pump filter, tanks and carburettors)	5) Carefully clean filters.

EXCESSIVE FUEL CONSUMPTION

POSSIBLE CAUSES	REMEDIES
1) Imperfect sealing of some needle valves.	1) Replace valves.
2) Faulty float (punctured or deformed).	2) Replace float.
3) Incorrect fuel level.	3) Reset correct level.
4) Main jets are defective or slow.	4) Check and replace if necessary.
5) Abnormal air correction jets.	5) Check and replace if necessary.
6) Obstructed air intake filter.	6) Wash it using petrol and blow from the inside. Replace if necessary.

BACKFIRES WHEN RELEASING THE ACCELERATOR

POSSIBLE CAUSES	REMEDIES
1) Irregular idling or adjusted with lean mixture.	1) Correctly adjust the idling of each carburettor.
2) Incorrect synchronization of carburettors opening.	2) Synchronize all carburettors.
3) Too lean carburation with little throttles opening.	3) Check carburation approximately to 1500 RPM.
4) Obstructed transition orifice.	4) Check.
5) Too low level in carburettors.	5) Reset correct level.
6) Sparking plugs too old or too hot.	6) Change sparking plugs with prescribed type.
7) Air leak from exhaust manifolds.	7) Eliminate air inlet.
8) Defective sealing of exhaust valves.	8) Check valve clearance and sealing.
9) Irregular ignition timing.	9) Check distributor timing.

OPERATING INFORMATION

NORMAL RUNNING

The fuel, through needle valve (12) passes into the bowl (8) where the float (9), hinged on pivot pin (10), controls the opening of needle (11) thus keeping fuel level constant. From bowl (8) fuel reaches wells (6) through main jets (7). After mixing with the air coming from the orifices of emulsifying tubes (5), fuel reaches, through air corrector jets (1) and nozzles (2) the carburation area consisting of auxiliary venturis (3) and venturis (4).

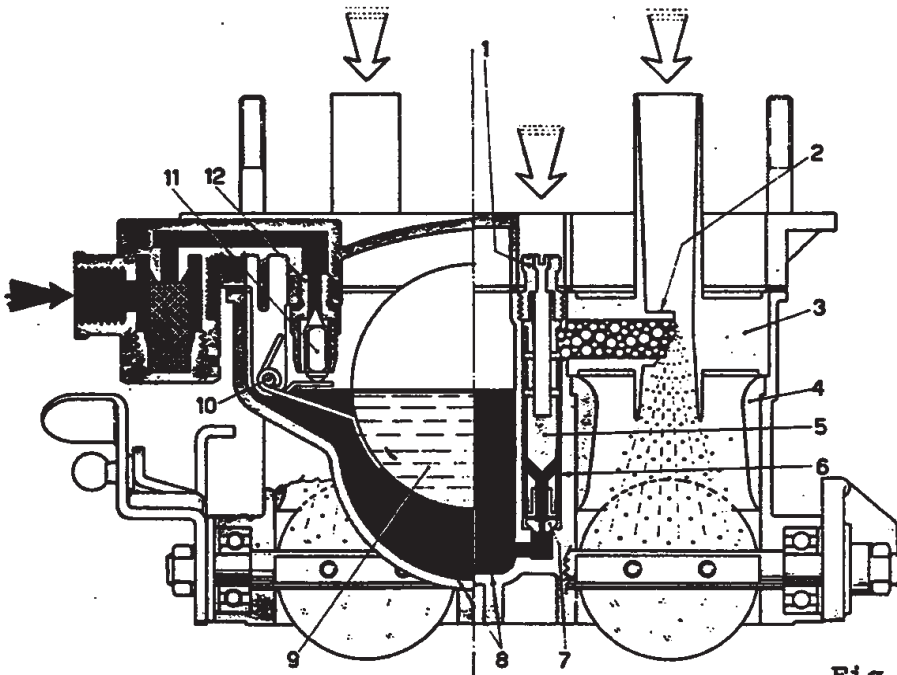

Fig. 14 - NORMAL RUNNING

IDLE SPEED - PROGRESSION

From wells (6) fuel reaches idle jets (19) through ducts (18); after emulsifying with the air coming from calibrated bushes (20), through ducts (17) and idle feed orifices (15) - the latter adjustable by screws (16) - it reaches carburetor ducts downstream of throttles (14). Starting from idle rate and upon gradual throttles opening, mixture reaches the carburetor ducts also through progression orifices (13) thus allowing smooth increase in engine angular speed.

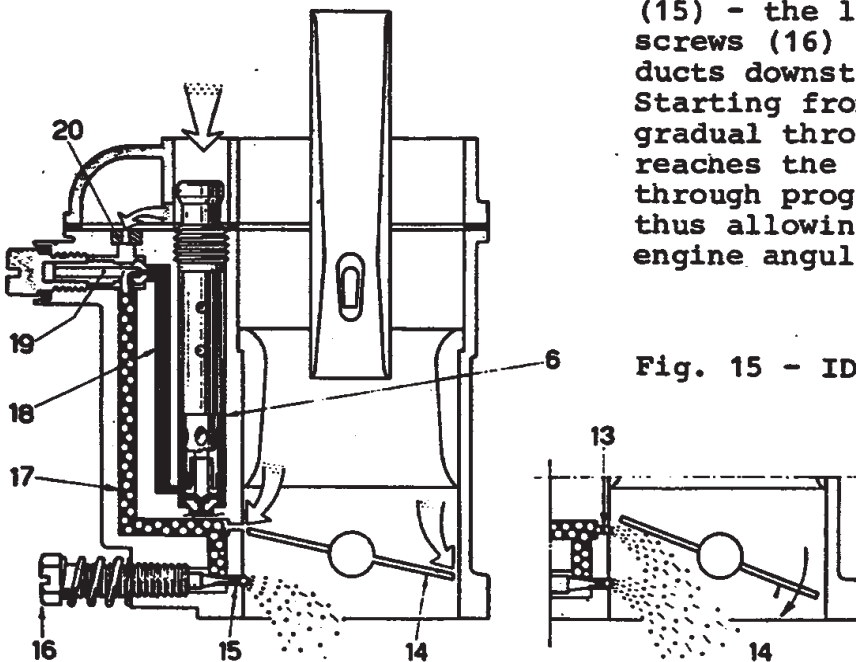

Fig. 15 - IDLE SPEED - PROGRESSION

ACCELERATION

Upon closing of throttles (14), lever (26) sets free the diaphragm (28) which, under the action of spring (24), draws fuel from the bowl (8) through the ball valve (30).

Upon opening of the throttles by means of cam (25) and lever (26), the diaphragm (28) injects fuel into the carburetor ducts through duct (23), delivery valve (22) and pump jets (21).

The spring (27) absorbs the openings of the throttles and prolongs fuel delivery. Any excess fuel delivered by the acceleration pump is discharged into the bowl (8) along with pump chamber vapours, through calibrated hole (29).

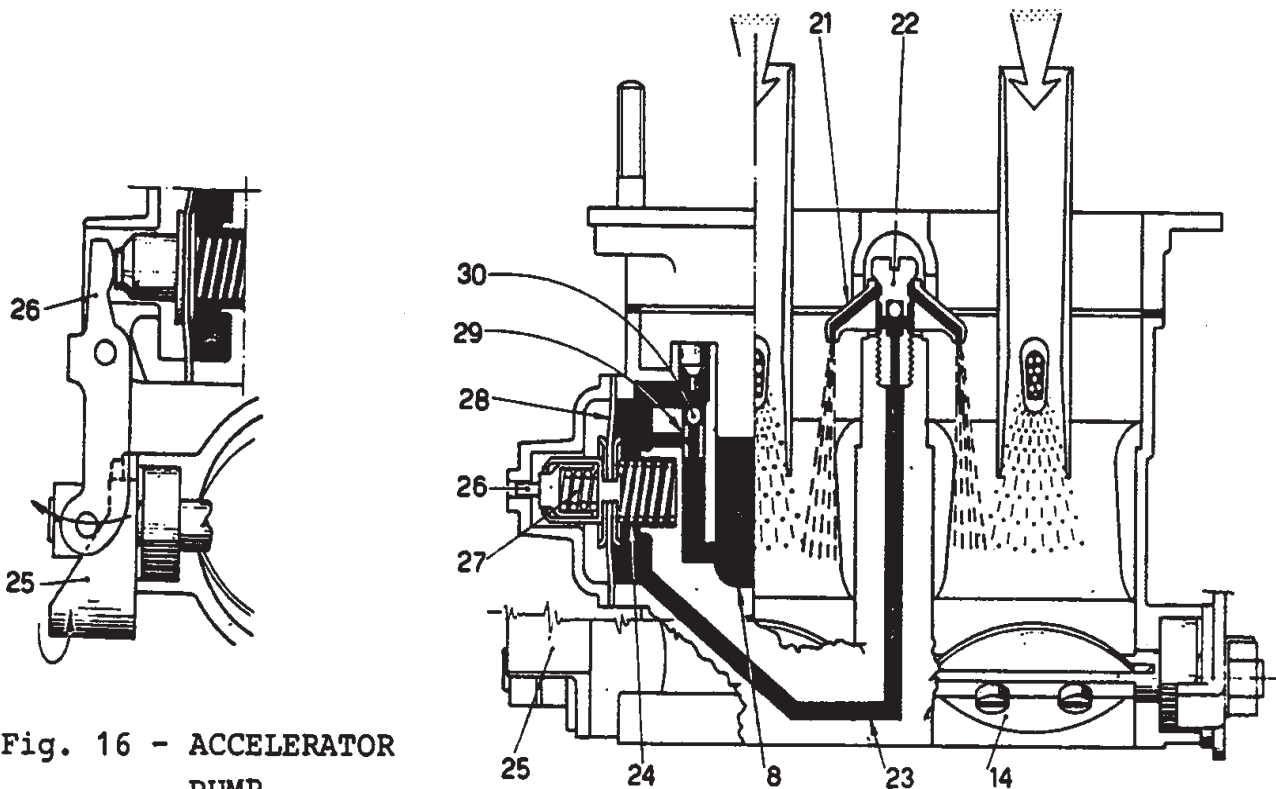

Fig. 16 - ACCELERATOR PUMP.

STARTING

The fuel, from bowl (8) reaches the starter device through ducts (34) and starting jets (32); after emulsifying with the air coming from the holes (31) it reaches valves seat (37) through ducts (33) and definitely emulsified with the air of orifices (36), it flows to the carburetor ducts downstream of throttles (14) through ducts (35).

COLD STARTING - Switch on device by pulling knob fully out - position "A".

STARTING WITH LUKEWARM ENGINE - Partial insertion of the device - position "B".

ENGINE WARMING UP - During this stage, even by vehicle running, progressively disengage starting device.

NORMAL VEHICLE RUNNING - DEVICE DISENGAGED - Position "C" as soon as engine reaches running temperature.

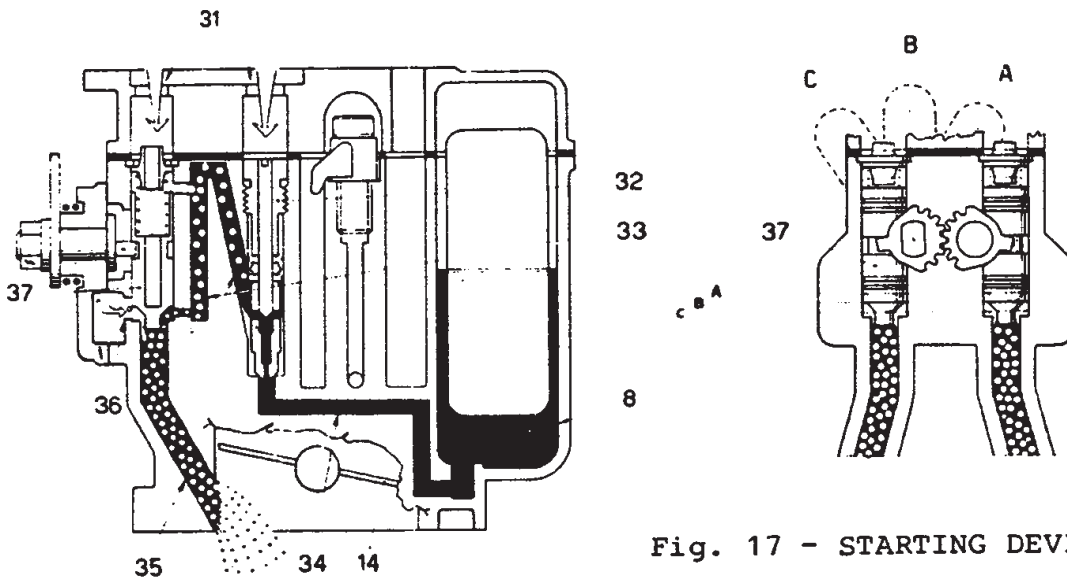

Fig. 17 - STARTING DEVICE.

CARBURETTORS SETTING DATA

DESCRIPTION	WEBER 40 DCNF 35/36/37/38	
Choke	mm.	32
Central diffusor	mm.	4,5 L
Main jet	mm.	1,30
Air correction jet	mm.	2,20
Emulsion tube		F 24
Slow running jet	mm.	0,45
Slow running air correction jet	mm.	1,60
Pump jet	mm.	0,45
Pump discharge	mm.	0,40
Needle valve	mm.	1,75
Pump delivery valve	mm.	0,50
Progression orifices	mm.	0,80 - 1,40 - 1,30 - 1,60 - 0,80
Protrusion of float without gasket	mm.	48
Opening of slow running adjusting screw	mm.	approx. 1 turn

FLOAT LEVEL ADJUSTMENT

To set the float level keep to the following instructions:

- Make sure that the needle valve (V) is perfectly tight in proper guide.
- Hold carburettor cover (C) in vertical position since the float (G) weight would lower the movable ball (Sf) fitted on needle (S).
- With carburettor cover (C) in vertical position and float tongue (Lc) lightly in touch with the ball (Sf) of needle (S), the float top should be 48 mm. from carburettor cover without gasket.
- Once the level adjustment has been effected, check that float (G)

- travel is mm. 10,5, modifying, if necessary, the position of grip (A).
- In case that float (G) is not correctly set, adjust the position of float tongue (L) to obtain the prescribed value; take care that the tongue (Lc) is perpendicular to the axis of needle (S) and it does not show dents which may affect the free movement of pin.
 - Check that float (G) runs freely around its fulcrum.

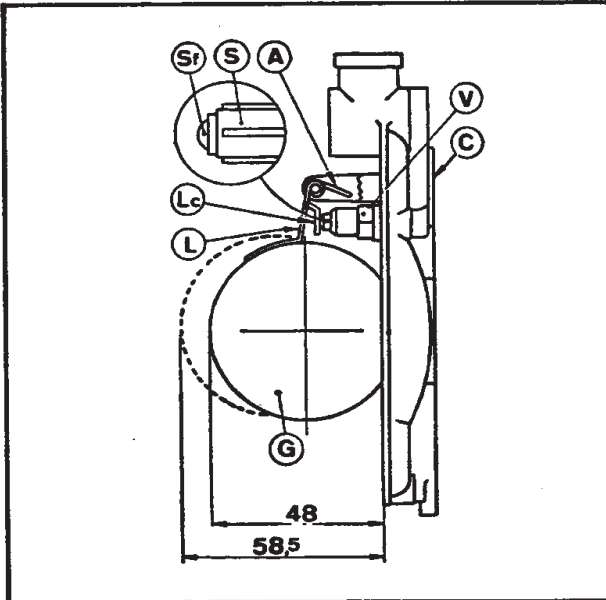

WARNING - In case the needle valve (V) must be replaced, make sure that the new valve is perfectly tight in proper guide, fit a new sealing gasket and repeat adjustment procedure.

Fig.18 - FLOAT LEVEL ADJUSTMENT

SYNCHRONIZATION AND ADJUSTMENT

Before starting this operation make sure that:

- carburetors are perfectly cleaned;
- jets are not obstructed;
- float levels are correct;
- ball joints of throttles levers have minimum play;
- engine is warm;
- by-pass screws are tightened.

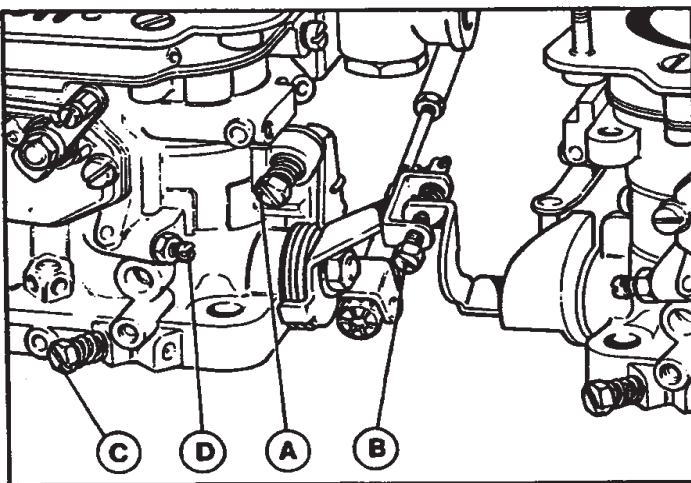

Fig. 19 - ADJUSTMENT and SYNCHRONIZATION.
A - Throttle opening adjusting screw; B - Carburetors synchronizing screw; C - Idle speed mixture adjusting screws; D - Screws for depression balancing in the carburettor ducts (by-pass).

Then proceed as follows:

- Remove air intake and filtering element.
- Perfectly tighten adjusting screws C then unscrew them for 3 turns.
- With the engine running, reach 900÷950 RPM by operating on the two

screws A.

- Using the motometer synchronizer adjust first the two carburettors of the left head (front) then adjust those of the right head (rear) by operating on screws B.
(Possible small differences between the two casings of each carburettor can be eliminated operating on screws D.)
- Using a motometer gauge, balance the two carburettor lines.
- Bring the value of idling back to 900±950 RPM by screwing or unscrewing the two screws A for same turns.
- In order to meter the mixture, operate the screws C for 1/4 of a turn each time until the required condition is achieved.

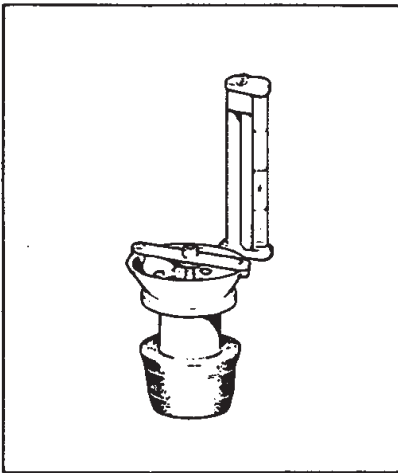

Fig. 20 - MOTOMETER SYNCHRONIZER with
AV 961-962 BASE.

To reach a good adjustment, it is advisable, however, to effect the CO analysis cylinder by cylinder using the suitable analysing pipes fitted to the manifolds.

The CO percentage, measured cylinder by cylinder, should be within 4 ± 4,5%.

SECTION **D**

CLUTCH
GEARBOX
REAR AXLE

	Page
CLUTCH	D 3
MAIN SPECIFICATIONS	D 3
TROUBLES AND REMEDIES	D 4
GENERAL INFORMATION	D 6
REPAIR INSTRUCTIONS	D 7
GEARBOX	D 9
MAIN SPECIFICATIONS	D 9
TROUBLES AND REMEDIES	D 10
GENERAL INFORMATION	D 11
GEARBOX ASSEMBLING	D 15
ADJUSTMENT OF GEARBOX LINKAGE	D 16
REAR AXLE	D 17
MAIN SPECIFICATIONS	D 17
TROUBLES AND REMEDIES	D 18
REPAIR INSTRUCTIONS	D 20
AXLE SHAFTS	D 21

C L U T C H

MAIN SPECIFICATIONS	Page D 3
TROUBLES DIAGNOSIS AND REMEDIES	" D 4
GENERAL INFORMATION	" D 6
REPAIR INSTRUCTIONS	" D 7
ADJUSTMENT OF CLUTCH RELEASE CONTROL	" D 7
ENGINE FLYWHEEL	" D 8
CLUTCH DRIVEN PLATE	" D 8
PRESSURE PLATE	" D 8

MAIN SPECIFICATIONS

Type		Dry single-plate
Outside diameter of facing	mm.	241,3
Inside diameter of facing	mm.	155,4
Thickness of driven plate without load	mm.	9,2 + 9,5
Thickness of driven plate under load	mm.	8,5
Wear limit of driven plate	mm.	1
Number of pressure plate springs		1 - diaphragm type
Pedal loading for clutch release	kg.	23 + 24
Clutch pedal free travel	mm.	20
Thrust washer free travel	mm.	2
Travel of hub for clutch release (without play).	mm.	12
Maximum backing of hub due to disc wear	mm.	8,3
Gap between flywheel surface and thrust disc.	mm.	52,5
Theoretic length of play adjusting rod	mm.	106
Misalignment of control lever fulcrum	mm.	5 + 6
Maximum wear of flywheel thickness	mm.	0,8
Flywheel surface roughness	μ	0,8

MAIN DATA OF HELPER SPRING

Length of free spring	mm.	68
Length of spring under static load	mm.	57
Corresponding load	kg.	16,3
Spring rate	mm./kg.	0,675

CLUTCH TROUBLES DIAGNOSIS AND REMEDIES

NOISE AUDIBLE WHEN PEDAL IS DEPRESSED

POSSIBLE CAUSES	REMEDIES
1) Throwout bearing excessively worn, damaged or badly lubricated.	1) Change bearing and sleeve.
2) Insufficient free travel of clutch pedal.	2) Adjust pedal travel.
3) Excessive clearance between hub of driven plate and clutch shaft.	3) Change driven plate.
4) Pedal throwout spring broken, weak or unhooked.	4) Change or reconnect.
5) Insufficient lubrication of clutch cable.	5) Lubricate cable or change it if worn.

CLUTCH GRABS

POSSIBLE CAUSES	REMEDIES
1) Oil or grease on flywheel, pressure plate and facings of driven plate.	1) Eliminate leakage of oil, carefully clean flywheel and pressure plate, then change driven plate.
2) Hub of driven plate not sliding freely on clutch shaft.	2) Eliminate the cause of such inconvenience; should it persist change the faulty item.
3) Pressure plate and flywheel are worn.	3) Check and replace if necessary.
4) Throwout mechanism works stiffly.	4) Locate cause of stiffness and remove it.
5) Driven plate facings badly worn (rivets rubbing on flywheel surfaces and on pressure plate.)	5) Replace driven plate (grind or replace flywheel).

SLIPPING CLUTCH

POSSIBLE CAUSES	REMEDIES
1) Clutch pedal failing to return due to lack of play.	1) Locate the cause and reset the play.
2) Oil or grease on facings of driven plate and flywheel.	2) Carefully clean flywheel and pressure plate; if driven plate is much oily, change it.
3) Facings of driven plate are too worn or burnt.	3) Replace driven plate.
4) Damaged throwout mechanism.	4) Check and change if necessary.

VIBRATING CLUTCH

POSSIBLE CAUSES	REMEDIES
1) Wrongly assembled clutch in relation to flywheel.	1) Check and, if necessary, turn it of 180°.

VIBRATING CLUTCH (continuation)

POSSIBLE CAUSES	REMEDIES
2) Unbalanced driven plate due to wear or broken facings.	2) Check: if it is still in good condition, check balancing and hub springs.
3) Crankshaft ball bearing is deteriorated or shows play.	3) Check and change if necessary.

ABNORMAL WEAR in FACINGS of DRIVEN PLATE

POSSIBLE CAUSES	REMEDIES
1) Insufficient free travel of clutch pedal.	1) Adjust free travel.
2) Driver keeps his foot on clutch pedal when running.	2) Driver must break this habit, putting foot on pedal only when necessary. Change worn parts.
3) Excessive sliding of driven plate when starting and changing speeds.	3) Avoid sliding.
4) Wrong positioning of control lever.	4) Check and adjust.

CLUTCH DRAGS

POSSIBLE CAUSES	REMEDIES
1) Excessive free travel of clutch pedal.	1) Adjust free travel.
2) Driven plate running out of true.	2) True up plate or change it.
3) Hub of driven plate does not slide freely on clutch shaft.	3) Locate cause and correct it; change driven plate if necessary.
4) Oil or grease on facings of driven plate.	4) Replace driven plate.
5) Facings of driven plate stuck on flywheel or on pressure plate due to long non-use of the vehicle.	5) Engage 1st speed, push the vehicle with fully pressed clutch pedal then roughly release it at intervals.

CLUTCH DOES NOT COMPLETELY DISENGAGE

POSSIBLE CAUSES	REMEDIES
1) Thrust bearing sleeve does not run freely on guide due to excessive dust from facings of driven plate.	1) Inject oil and petroleum on clutch shaft. If necessary, disassemble the clutch.
2) Pedal got bind into bushes.	2) Disassemble clutch shaft and remove the inconvenient.
3) Engine idling too high.	3) Adjust idling.
4) Driven plate running out of true	4) True up plate or change it.

CLUTCH PEDAL TOO HEAVY

POSSIBLE CAUSES	REMEDIES
1) Thrust bearing sleeve does not run freely on guide due to excessive dust from the facings of driven plate. 2) Control cable partially bound in proper sheath. 3) Excessive offset of control lever fulcrum. 4) Wrong angular position of levers.	1) Inject oil and petroleum on clutch shaft. If necessary, disassemble the clutch. 2) Check, grease and change part if necessary. 3) Check and re-set correct position. 4) Check and adjust.

GENERAL INFORMATION

The clutch is of the dry, single-plate type with a spring hub, diaphragm spring and mechanical release incorporating a helper spring. The release is carried out via a ball thrust bearing mounted on a sliding sleeve.

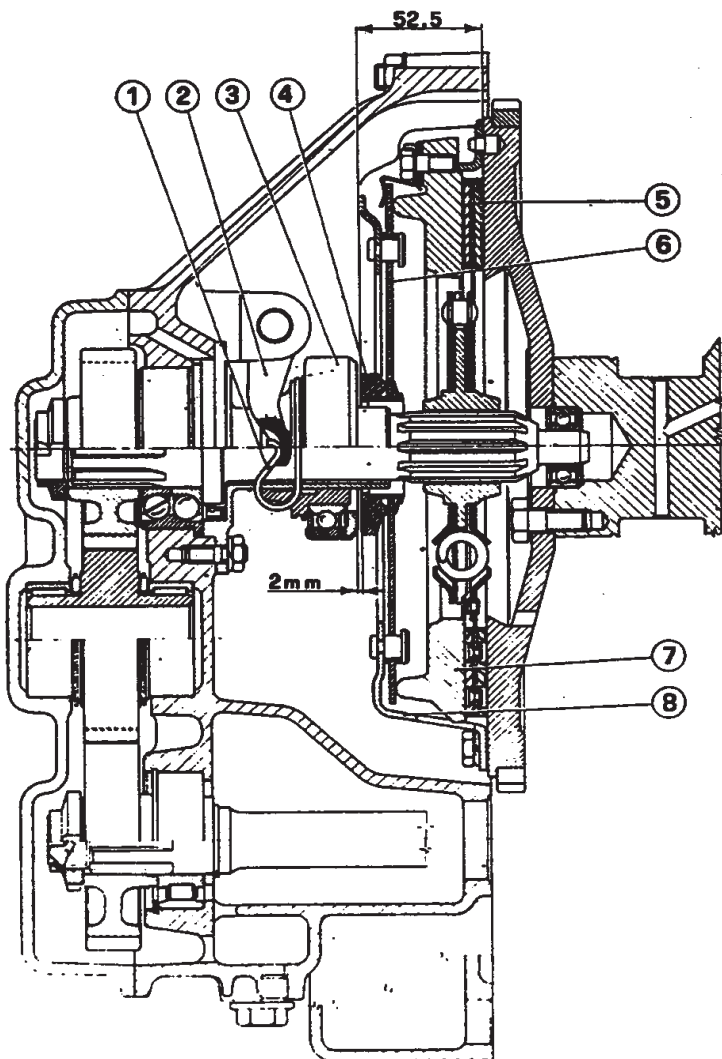

Fig. 1 - LONGITUDINAL SECTION of CLUTCH:

1 - Spring, coupling for thrust ring; 2 - Clutch control lever
 3 - Thrust bearing; 4 - Thrust ring; 5 - Driven plate; 6 - Diaphragm spring; 7 - Pressure plate; 8 - Clutch housing.

REPAIR INSTRUCTIONS

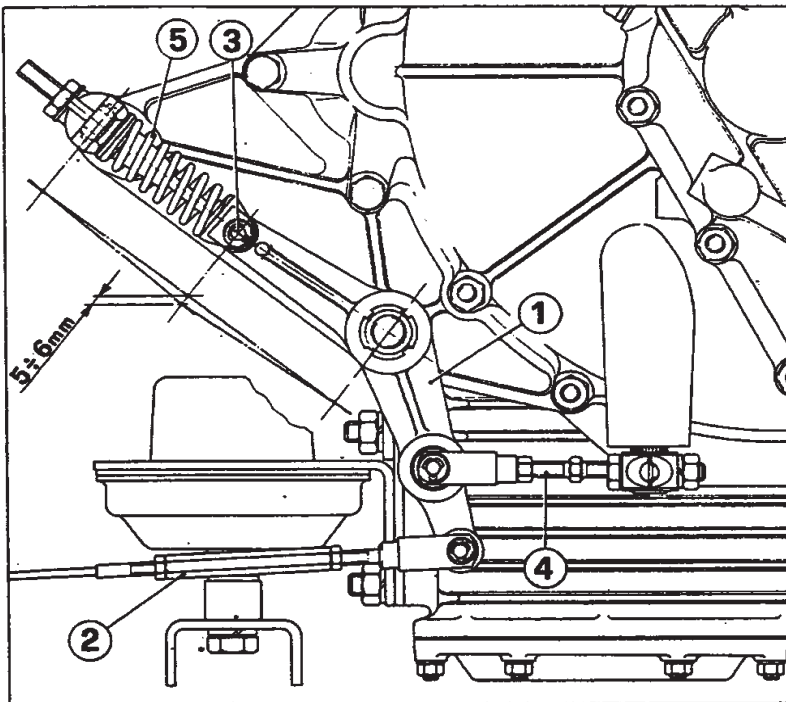

Fig. 2 - CLUTCH CONTROL MECHANISM.

1- Lever; 2- Adjusting sleeve; 3- Fulcrum; 4- Tie rod; 5- Helper spring.

ADJUSTMENT OF CLUTCH CONTROL

For an efficient operating of clutch control, levers must be exactly in rest position as shown in above figure. Particularly, verify the fulcrum 3 misalignment which should be of 5+6 mm. To make easier this operation, a reference hole has been drilled on the clutch housing front side.

For adjustment procedure, do as follows:

Disconnect tie rod 4 from lever 1.

Acting on sleeve 2, bring the hole of lever 1 exactly in line with the hole on clutch housing. (In this position, the correct misalignment of 5-6 mm. is ensured).

Connect the tie rod 4 to lever 1 and give the necessary clearance to clutch by acting on the relevant register 4.

Warning : In rest position the lever 1 must be in a direction that the hole on the lever and the one on clutch housing are exactly lined up.

Periodically clean the release sleeve from the dust coming from disc wearing. Keep well greased the joints and the upper shim of the helper spring.

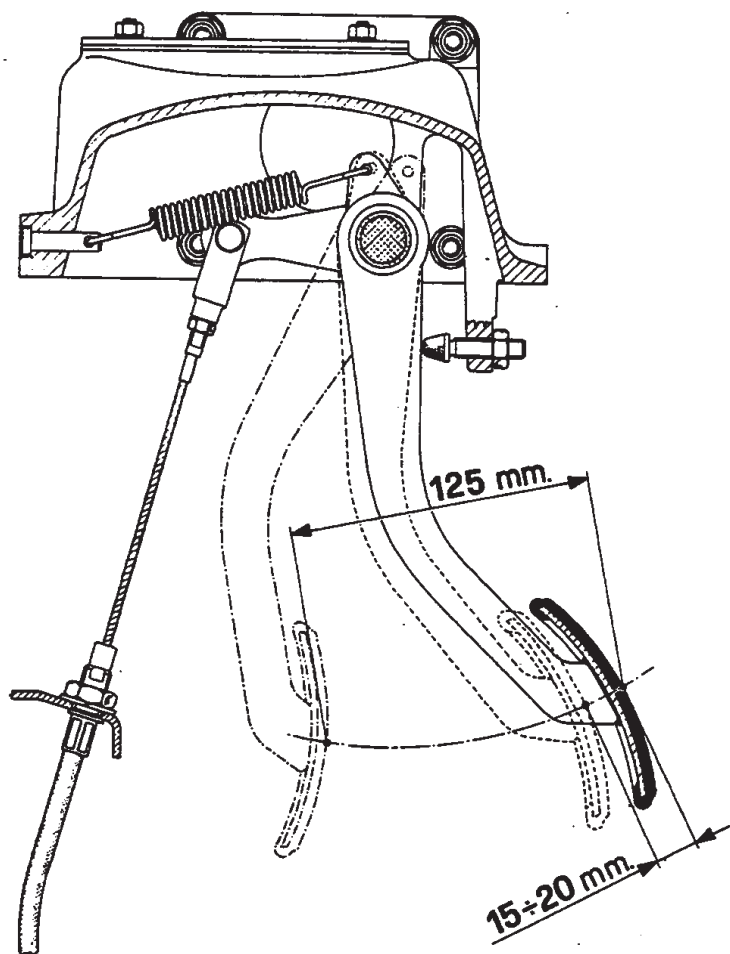

Fig. 3 - CLUTCH CONTROL.

ENGINE FLYWHEEL

Check the conditions of working face; in case it shows cracks, grind it but removing as few material as possible. Maximum reduction of thickness is mm. 1. The grinded surface must be well smooth and perfectly parallel to the face on crankshaft side.

CLUTCH DRIVEN PLATE

- Check whether the working faces are impregnated with oil or grease. If so, replace the disc.
- Check the wear of working faces; see page D 3 for the relevant values.
- Check that gasket fixing nails are well locked.
- Check that driven plate hub runs freely and without excessive play in the clutch shaft splines.
- Check that the spring drive is well locked on the hub.
- Using a dial gauge check the axial run-out of the driven plate side faces; put the driven plate on a chuck and this on two centers.

PRESSURE PLATE

Check the driven plate working face: should it show cracks, replace it.

Check that there is no clearance on all riveted items.

The clutch cover is fixed to engine flywheel with six bolts and is hold true by three dowels.

The spare diaphragm spring/pressure plate ring group and clutch disc are supplied already balanced. Therefore their replacement does not require further balancing.

G E A R B O X

MAIN SPECIFICATIONS	Page D 9
TROUBLES DIAGNOSIS AND REMEDIES	" D 10
GENERAL INFORMATION	" D 11
SYNCHRONIZERS	" D 11
CHECKINGS AND OVERHAULINGS	" D 12
GEARBOX ASSEMBLING	" D 15
ADJUSTMENT OF GEARBOX LINKAGE	" D 16

MAIN SPECIFICATIONS

Speeds	5 forward + reverse
Synchronizers on forward speeds	Floating rings
Radial play between idle gears and bearings (For 1st, 2nd, 3rd speeds and reverse (For 4th and 5th speeds	mm. 0,023+0,058 mm. 0,022+0,054
Axial play between idle gears and thrust rings - Limit of wear	mm. 0,27 + 0,31 mm. 0,35
Axial play of reverse idle gear	mm. 0,20 + 0,30
Backlash	mm. 0,03 + 0,05
Clearance between forks and sleeves	
Axial play (For 1st, 2nd, 3rd speeds and reverse (For 4th and 5th speeds	mm. 0,20 + 0,60 mm. 0,40 + 0,55
Radial play on diameter (For 1st, 2nd, 3rd speeds and reverse (For 4th and 5th speeds	mm. 1,25 + 1,55 mm. 1,20 + 1,60
Clearance between control rods and relevant holes	mm. 0,016+0,061
Shafts disalignment	mm. 0,02
Splash lubrication	

GEARBOX RATIOS

SPEED GEARS RATIOS		
1st	40 : 13	3,076
2nd	37 : 17	2,117
3rd	32 : 21	1,523
4th	28 : 25	1,120
5th	24 : 28	0,857
Reverse	38:13	2,953

RATIOS WITH IDLE GEAR 27 : 30	
1st	3,418
2nd	2,353
3rd	1,693
4th	1,244
5th	0,952
Reverse	3,247

ENGINE:WHEELS REVS RATIO WITH CROWN AND PINION 17:63 RATIO	
1st	12,669
2nd	8,719
3rd	6,274
4th	4,611
5th	3,529
Reverse	12,036

GEARBOX TROUBLE DIAGNOSIS AND REMEDIES

NOISY GEARBOX

POSSIBLE CAUSES	REMEDIES
1) Excessive backlash between gear teeth due to wear.	1) Overhaul gearbox and change worn gears.
2) Gears, bearings and synchronizers worn.	2) Overhaul gearbox and change worn parts.
3) Shafts out of alignment.	3) Check shafts alignment.
4) Too low oil level in gearbox.	4) Top up with oil to lower brim of the filler plug seating.

DIFFICULT GEARSHIFTING

POSSIBLE CAUSES	REMEDIES
1) Selector bar bent.	1) Remove and true up bar or replace it.
2) Selector bars jamming in housing seats.	2) Check and adjust.
3) Dirt in splines preventing sliding sleeves from running freely.	3) Locate cause of trouble, clean thoroughly and change faulty parts.
4) Unsuitable grade of oil in gearbox.	4) Dismantle gearbox and wash out thoroughly. Refill with prescribed oil.
5) Clutch not disengaging completely.	5) Check clutch mechanism.
6) Worn synchro rings.	6) Replace synchro rings.
7) Weak springs with insufficient load.	7) Check and change if necessary.
8) Worn synchronizers pads.	8) Check and change if necessary.
9) Insufficient clearance between sleeves and synchronizers due to deformation.	9) Check and change if necessary.

GEARS JUMPING OUT of MESH or MESHING INCORRECTLY

POSSIBLE CAUSES	REMEDIES
1) Gear not properly engaged.	1) Engage gear completely before releasing clutch pedal.
2) Balls worn or weak springs (keeping in position the control rods).	2) Remove lower cover and overhaul parts.
3) Teeth of sliding sleeve or of gear worn.	3) Check and change faulty parts.
4) Worn synchro rings.	4) Replace synchro rings.

GENERAL INFORMATION

Gearbox with five forward speeds and reverse.

All forward synchronized speeds with floating rings.

All forward gears are constant-mesh with helical teeth to reduce the noise to minimum.

The gearbox is placed under the engine. The following are the gearbox main components:

- Main box in light alloy.
- Engine oil sump which is an integral component of the gearbox and is placed parallelly to gearbox. Lubrication is however separated.
- Case for rear axle and differential which is an integral component of gearbox and is placed parallelly to it.
- Right side cover with speed indicator drive.
- Lower cover of oil sump and gearbox with plugs for oil draining.

SYNCHRONIZERS

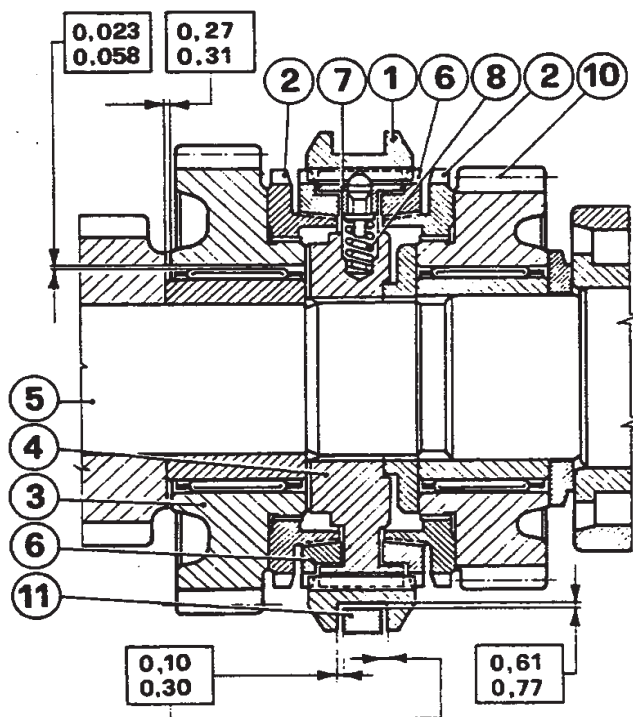

Fig. 4 - SYNCHRONIZER FOR 1st, 2nd and 3rd SPEEDS.

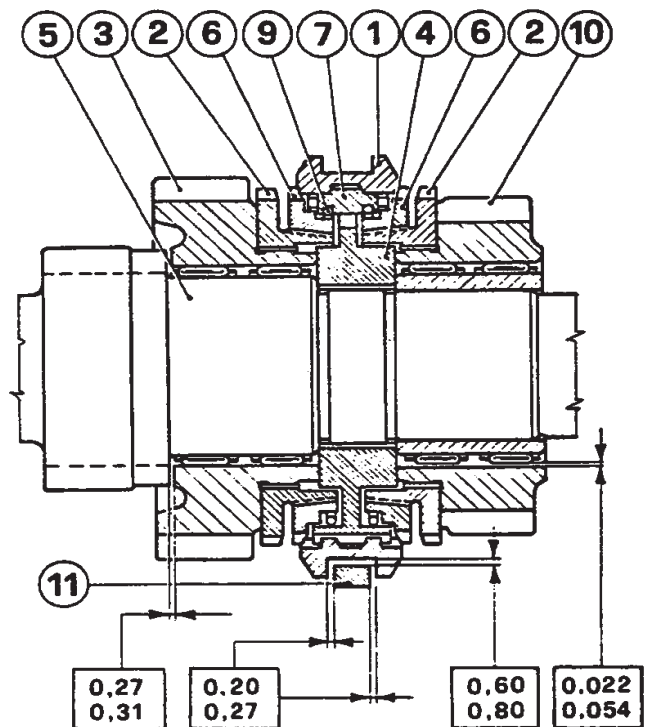

Fig. 5 - SYNCHRONIZER FOR 4th and 5th SPEEDS

1 - Sliding sleeve; 2 - Synchro hub; 3 - Gear; 4 - Synchronizer; 5 - Shaft; 6 - Synchro ring; 7 - Pressure pads; 8 - Spiral spring; 9 - Ring spring; 10 - Gear; 11 - Fork.

The forward speeds synchronization is obtained by the parts shown in figures 4 and 5.

The sliding sleeve (1) has an internal toothing which engages with the synchro hub (2) of gear (3) thus connecting it stiffly to the synchronizer (4) then to shaft (5).

Making the sliding sleeve (1) move in an axial movement to the right or left side, in the same time also the synchro ring (6) is moved by the pressure pads (7) which are pressed in a radial way against the sleeve by the coil springs (8) (fig.4) or by the ring springs 9 (Fig. 5). Therefore the conical surface of synchro ring is pressed on the corresponding conical surface of the synchro hub.

Due to the small angle of incidence between the two conical surfaces,

radial forces appear on the gear (10) dragging it in rotation thus reducing the differences of angular speed between gear (10) and synchronizer (4), i.e., between shaft (5) and gear. Soon after the synchronization between the parts, a further movement of sleeve takes place, making the definite coupling between gear (10) and synchronizer (4).

CHECKINGS AND OVERHAULINGS

1) GEARS

After removing of gearbox parts, wash them with petroleum and blow with compressed air.

- Check housing and covers for possible cracks and make sure that seats for ball bearings outside rings do not present scores or wear signs.
- Make sure that ball bearings and roller bearings are in good efficiency conditions; replace them if they appear rough or noisy when rolling.
- Make sure that profile surfaces of gear teeth do not present scratches, wear or seizing signs. They should appear smooth and show a uniform contact surface on the whole length.
- Check that races for needle bearing do not present abnormal wear. Radial play should not exceed the prescribed value.
- Check inner side wear of sleeve and forks. It is important that the two forks contact surfaces keep the sleeves perpendicular in relation to forks axis. (Maximum axial run-out 0,05 mm.).
- Check that side working surfaces of idle gears and spacers do not present wear or seizing.
- Check that drive teeth of sleeves and idle gears do not present burrs or wearing which would make the engaging difficult.

2) SYNCHRONIZERS

Main Data

SPEED	LIMIT of WEAR X	SYNCHRONIZER CLEARANCE Y	LOAD P on SLEEVE
1st - 2nd - 3rd	0,4 mm.	$\cong 0,5$ mm.	17 + 25 kg.
4th - 5th	0,4 mm.	$\cong 0,4$ mm.	25 + 34 kg.

The synchro rings for 1st - 2nd and 3rd speeds are identical but differ from those of 4th and 5th speeds. It is advisable to replace synchro rings when disassembling gearbox if they have run over 30000 km. A checking for wear can be effected in the following way:

- True the synchro ring on the corresponding clutch cone. The two cones, helped by a radial rotation, should mate in a uniform and parallel way. Using a thickness gauge, check the distance between clutch cone carrier and synchro ring in different points opposed on diameter.

If the distance is less than the prescribed value, replace the ring. During this operation, visually check that the male cone does not present smoothing, seizing or overheated areas.

- When fitting new parts, check the synchronizer clearance. Fit the synchro ring to relevant clutch cone. By a radial rotation, make the two cones mating in a parallel and uniform way. Put the synchro hub in position of assembling on the working surface of the gear or the spacer (3rd speed).

Select the thickness gauge blade corresponding to the minimum clearance allowed by the synchronizer.

The selected blade should be easily inserted between synchro ring and synchronizer along the whole perimeter.

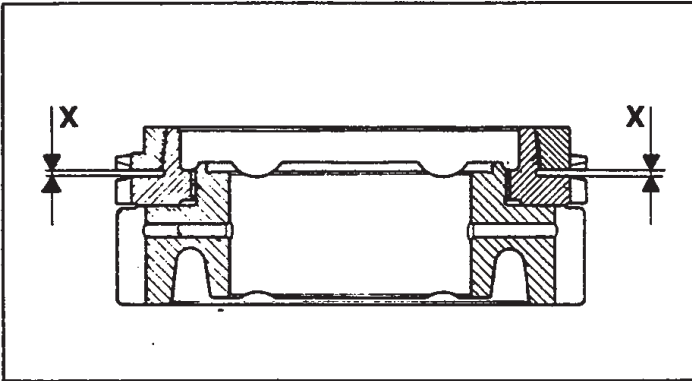

Fig. 6 - CHECKING WEAR of SYNCHRO RING.

The upper limit of synchronizer clearance is determined by the wear limit of synchro ring.

Mark the parts on which the measure has been taken to avoid any exchange with other synchronizer groups.

- Make sure that each synchronizer unit has the prescribed axial load. This load must be checked from both sides.

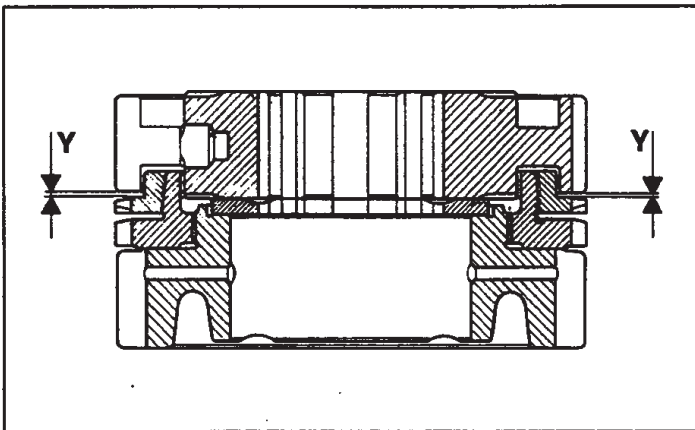

Fig. 7 - CHECKING SYNCHRONIZER CLEARANCE.

Introduce the synchro unit into a retaining element as shown in figure. Turn the synchro ring in a way that the drive tooting of sleeve can directly insert in the corresponding tooting on the gear synchro hub. Load the sleeve in a uniform way until it engages the gear. Should the prescribed load not be reached, this is probably due to the springs weakened therefore they must be replaced.

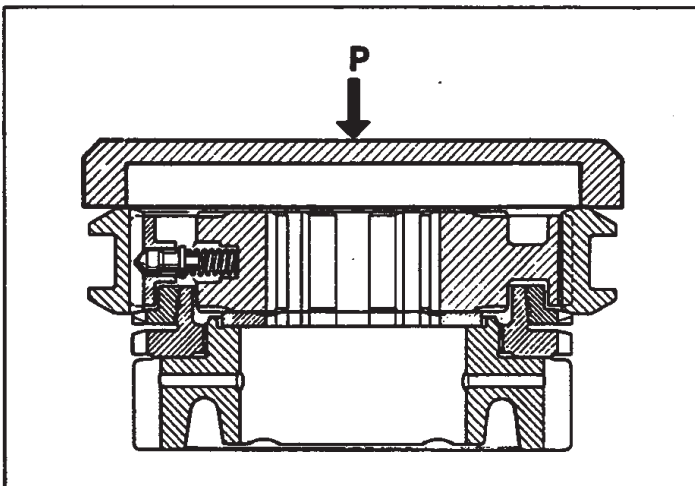

Fig. 8 - CHECKING SYNCHRONIZER AXIAL LOAD.

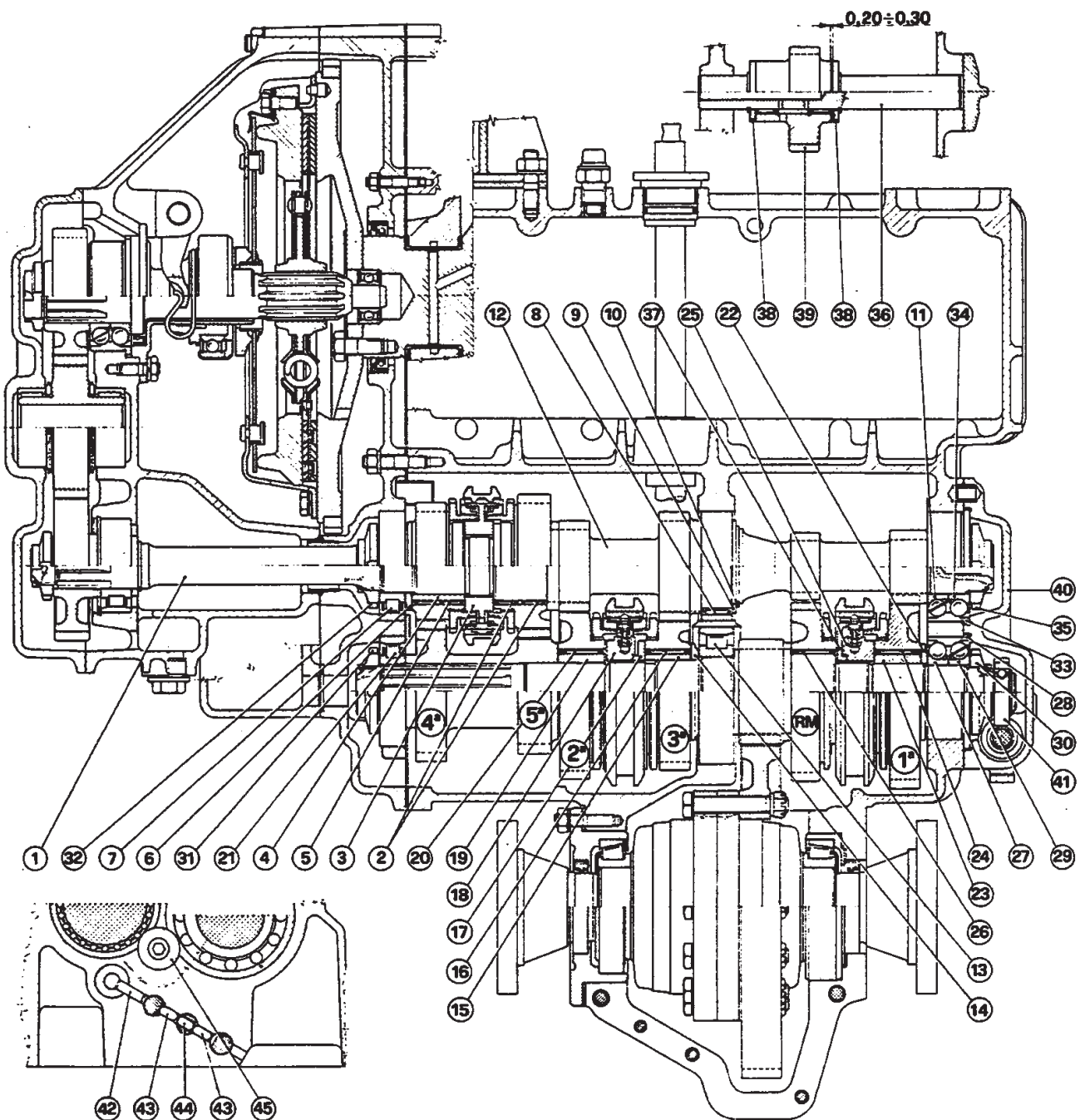

Fig. 9 - SECTION of GEARBOX ASSEMBLY.

1 - Main shaft; 2 - Needle bearing; 3 - Synchronizer; 4 - Race for needle bearing; 5 - Needle bearing; 6 - Spacer; 7 - Roller bearing; 8 - Needle bearing; 9 - Spacer; 10 - Lock ring; 11 - Bearing inner race; 12 - Layshaft; 13 - Roller bearing; 14 - Spacer; 15 - Race for needle bearing; 16 - Needle bearing; 17 - Spacer; 18 - Synchronizer; 19 - Race for needle bearing; 20 - Needle bearing; 21 - Roller bearing; 22 - Spacer; 23 - Race for needle bearing; 24 - Needle bearing; 25 - Synchronizer; 26 - Needle bearing; 27 - Half-bearing; 28 - Race for bearing; 29 - Half-bearing; 30 - Ring nut; 31 - Ring nut; 32 - Ring nut; 33 - Outside race; 34 - Half-bearing; 35 - Ring nut; 36 - Shaft for reverse idle gear; 37 - Spacer; 38 - Spacer; 39 - Reverse idle gear; 40 - Side cover; 41 - Worm screw for speedometer control; 42 - Pin; 43 - Needle for rods stop; 44 - Needle for rod stop; 45 - Washer.

GEARBOX ASSEMBLING (see fig. 9)

Warning : Gearbox must be assembled after that crown-differential unit has been introduced in the case.

- Introduce the outside races of central bearings in their seats on the case then fix them with proper washers (45). Lock the nut with a drop of locktite.
- Prepare the two shafts with proper bearings, gears and synchronizer groups.
- Put the main shaft (1) on a vice, introduce the two needle bearings (2), the idle gear of 5th speed, the synchronizer hub (3) of 4th and 5th speeds (with synchro rings, springs and sleeve), the race for needle bearing (4), the two needle bearings (5), the idle gear of 4th speed, spacer (6) and roller bearing (7).
Then introduce, from the other end of mainshaft, the needle bearing (8), the spacer (9), the lock ring (10) and the inner part (11) of the double-row ball bearing.
- Put the layshaft (12) on a vice; insert the roller bearing (13) on the splined side, spacer (14), the race for needle bearing (15), the needle bearings (16), the 3rd gear, the spacer (17), the synchronizer (18) (with synchro rings, springs and sleeve), the race for needle bearing (19), the needle bearings (20), the 2nd speed idle gear, the fixed unit of 4th and 5th speeds, then, to end drive the roller bearings (21) on the shaft.
- Prepare the 1st speed/reverse unit including the race for needle bearing (23), needle bearing (24), the 1st speed idle gear, the synchronizer (25) (with synchro ring, springs and sleeve), the spacer (37), the needle bearing (26) and the reverse sliding gear.
- Place these items inside the gearbox. Then partially insert the layshaft and mainshaft on the case. Then drive in them completely taking care to insert the 1st speed and reverse unit on the layshaft.
- Insert the spacer (22) on the side of 1st speed; drive on the shaft the half-bearing (27), the outside race of bearing (28), the half-bearing (29). Then screw by hand the two ring nuts (30) and (31). Screw also the ring nut (32) on the mainshaft.
- Drive the outside race (33) on the case and the half-bearing (34) on mainshaft, then screw by hand the ring nut (35).
- Fit on the case the shaft (36) for reverse idle gear. Insert the two lock rings and the two needle bearings in the idle gear. Insert everything on shaft 36 (together with the two spacers 38) then lock with the two stop rings.
- Insert in the layshaft the ball and worm screw (41) for speedometer; sleeve forks without locking them and the relevant control forks.
- Insert the reverse and one forward gear then lock the ring nut to the torque prescribed in table of page M 6, using the wrench 175-AS-5568.
- Make sure that the axial play of idle gears and reverse idle gear is within the limits shown in table.
- Insert the layshaft the ball and worm screw (41) for speedometer; then fit the side cover (40) spreading the sealing surfaces with paste CAF 4 or CAF 1.
- Introduce in their seats the three small balls with washers and springs pressing them with a plate.
To align the control forks, use tool 706-AS-9561. Keep the rod of 2nd and 3rd speeds, which have the fork in a non-adjustable position, in a way that the tool placed on the groove is vertical and free in the other two forks.
- Tighten the clamps screws of the mentioned forks and those of the drive forks. Make sure that when in neutral the forks are true in

relation to relevant gears.

Warning : The three control rods have three seats each one: one for neutral position and two for engaged speed position. Make sure of regular engaging stroke.

- Set in proper seating the support with the three levers for speeds control.
- Fit the gearbox lower cover with proper gasket.
- Manually check that the three control rods can oscillate to and fro.
- Now the gearbox can be joined to the engine and to the clutch assembly.

ADJUSTMENT OF GEARBOX LINKAGE

In order to set correctly in position the control rods, act as follows:

- Check for rod joints play.
- Insert the 2nd gear (To do this, make sure that the rubber bushing (7) on rod (6) is horizontal then push the rod inside the gearbox thus engaging 2nd speed).
- Bring lever (1) in 2nd speed then introduce the bolt in fork (3) connecting the rod (6). Tighten the nut.
- Put lever (1) in neutral and check that it is equidistant in relation to the selector (2) grooves for 2nd and 3rd speeds. Operate on sleeve (4) with left and right threading and on the two lock nuts (5) in order to eliminate any possible differences.
- Bring again lever (1) in 2nd speed, remove the screws fixing the selector and check that the lever lateral movements are equal in relation to central position. If differences are noticed, move only one lock nut (5) and move the lever as far as necessary. Tighten again the lock nut and re-fit the selector.
- To end, make sure of the lever correct position in all speeds.

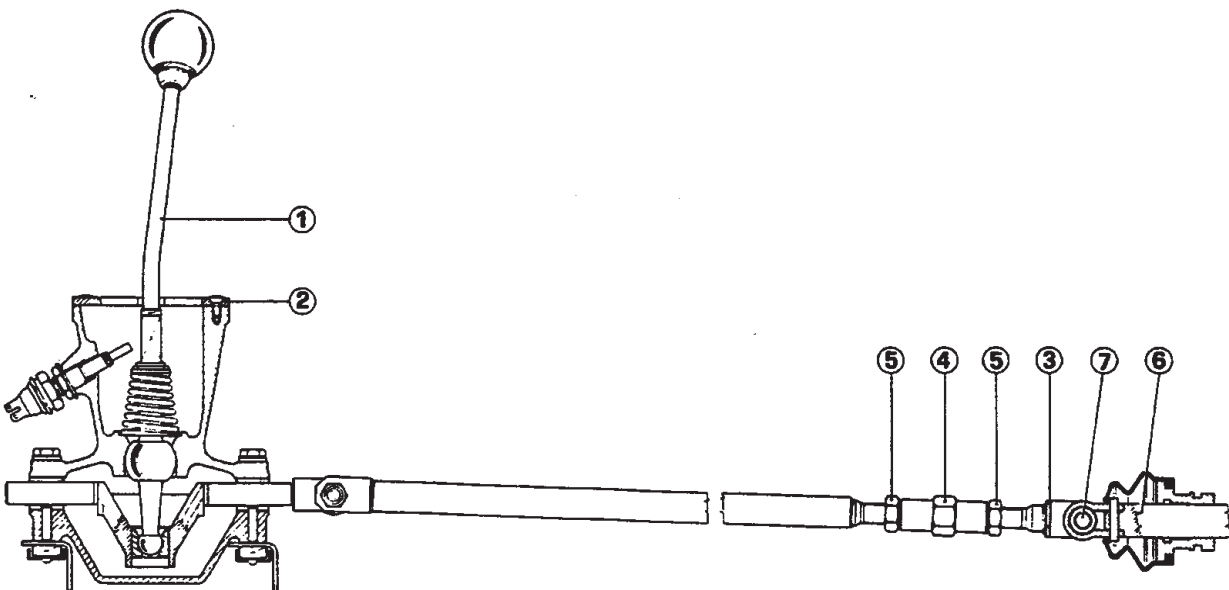

Fig. 10 - GEARBOX CONTROLS.

1- Control lever; 2- Selector; 3- Fork; 4- Adjusting sleeve; 5- Adjusting lock nuts; 6- Gearbox control rod.

R E A R A X L E

GENERAL INFORMATION	Page D 17
MAIN SPECIFICATIONS	" D 17
TROUBLES DIAGNOSIS AND REMEDIES	" D 18
REPAIR INSTRUCTIONS	" D 20
CHECKING	" D 20
BEARINGS PRELOADING	" D 20
AXLE-SHAFTS	" D 21
CHECKING	" D 21

GENERAL INFORMATION

- The unit includes one case and one steel cover which hold the cylindrical crown with helical teeth between their flanges. The crown engages with the relevant pinion on the gearbox layshaft. The transmission ratio is 17/63.
- In addition to crown and planet wheels with conical toothing, in the case there are limited-slip clutches controlling the rear wheels.
- The rear axle steel discs are 4 on each side and have surfaces made rough by a proper molybdenum treatment.
- The preloaded taper roller bearings support the unit in the case which is a part of the gearbox. On each side of the differential there are two flanges connecting the axle-shafts.
- Lubrication is in common to that of gearbox.

MAIN SPECIFICATIONS

Type	Swinging shafts
Differential assembly	With limited slip unit
Cylindrical crown and pinion	With helical teeth
Reduction ratio	17/63
Bearings for differential box	No. 2
Bearings	Conical roller type
Preloading adjustment	By spacing washers
Bearings preloading (new): measured with pulley \varnothing 200	P = kg.2,280+4,030
Pinion and cylindrical crown	Coupled
Backlash	mm. 0,03 + 0,04
Clearance of wear limit	mm. 0,12
Axle-shafts	Swinging type
Lubrication oil	AGIP F 1 ROTRA HY SAE 80 or MP SAE 90
Limited slip percentage	40%

TROUBLES DIAGNOSIS AND REMEDIES

NOISY DIFFERENTIAL

POSSIBLE CAUSES	REMEDIES
1) Differential bearings not properly adjusted or worn.	1) Check preloading and replace worn bearings.
2) Wearing of teeth surface of pinion or crown.	2) Change worn parts.
3) Excessive play between gear teeth.	3) Replace the gears.
4) Unsuitable grade of oil.	4) Replace oil with prescribed quality.
5) Insufficient oil in unit.	5) Check for possible leaks and top up level.
6) Limited slip unit ineffective (worn discs).	6) Check and replace worn parts.

NOISE WHEN PULLING

POSSIBLE CAUSES	REMEDIES
1) Differential case bearing not properly adjusted or worn.	1) Check preloading and replace worn bearings.
2) Slack axle-shafts universal joints.	2) Replace axle-shafts.
3) Lack of lubrication of parts.	3) Check for leaks then top up level.

NOISE ON OVERRUN

POSSIBLE CAUSES	REMEDIES
1) Excessive play between gear teeth.	1) Replace the gears.
2) Slack axle-shafts universal joints.	2) Replace axle-shafts.
3) Differential bearings not properly adjusted or damaged.	3) Check preloading and replace worn bearings.

NOISE ON BENDS

POSSIBLE CAUSES	REMEDIES
1) Limited slip discs worn or damaged.	1) Dismantle the limited slip unit and change worn discs.
2) Lack of clearance between the inner box components due to wrong assembly or seizing.	2) Replace worn parts and check all matings.
3) Unsuitable grade of oil.	3) Change it.

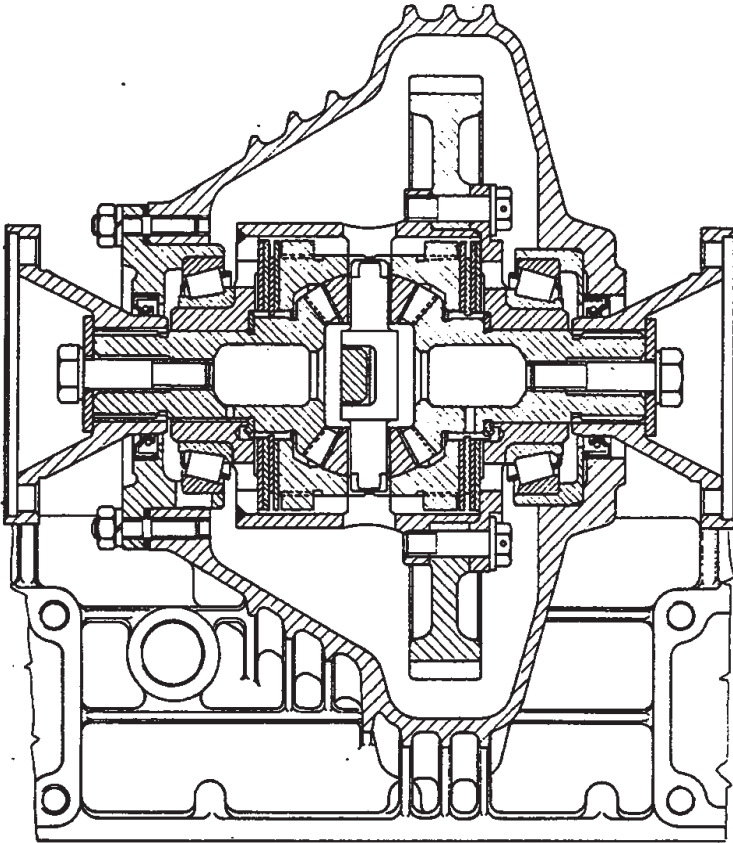

Fig. 11 - LIMITED SLIP
DIFFERENTIAL PLATE TYPE
(VALID UP TO GEARBOX
No. 692)

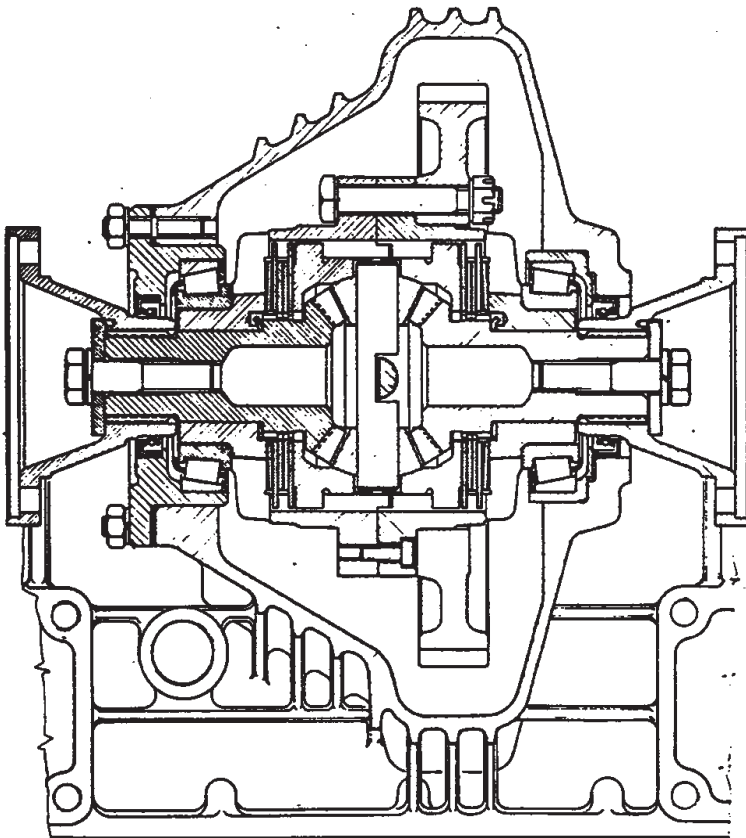

Fig. 12 - LIMITED SLIP
DIFFERENTIAL PLATE TYPE
(VALID FROM GEARBOX
No. 693)

Warning : The two differentials are not interchangeable as their replacement would require also the replacement of the crown gear and of the gearbox layshaft.

REPAIR INSTRUCTIONS

CHECKING

- Make sure that sides surface of pinion and crown teeth is smooth and do not present scratches; otherwise, replace both the parts.
- Check roller bearings for efficiency and check whether the outer and inner rings are still forced in their seats. Replace bearings should they be noisy.
- Check the lateral oil rings, make sure of the efficiency of discs surfaces and check for wear the outer and inner teeth of discs. Replace differential discs in case they are too smooth.
- Check the pressure rings of limited slip unit and the planet wheel pins.
- Check the teeth surfaces of crown and planet wheels and the clearance in their seats.
- Make sure of the efficiency of crown fixing bolts and check the holes threading in the box.

BEARINGS PRELOADING

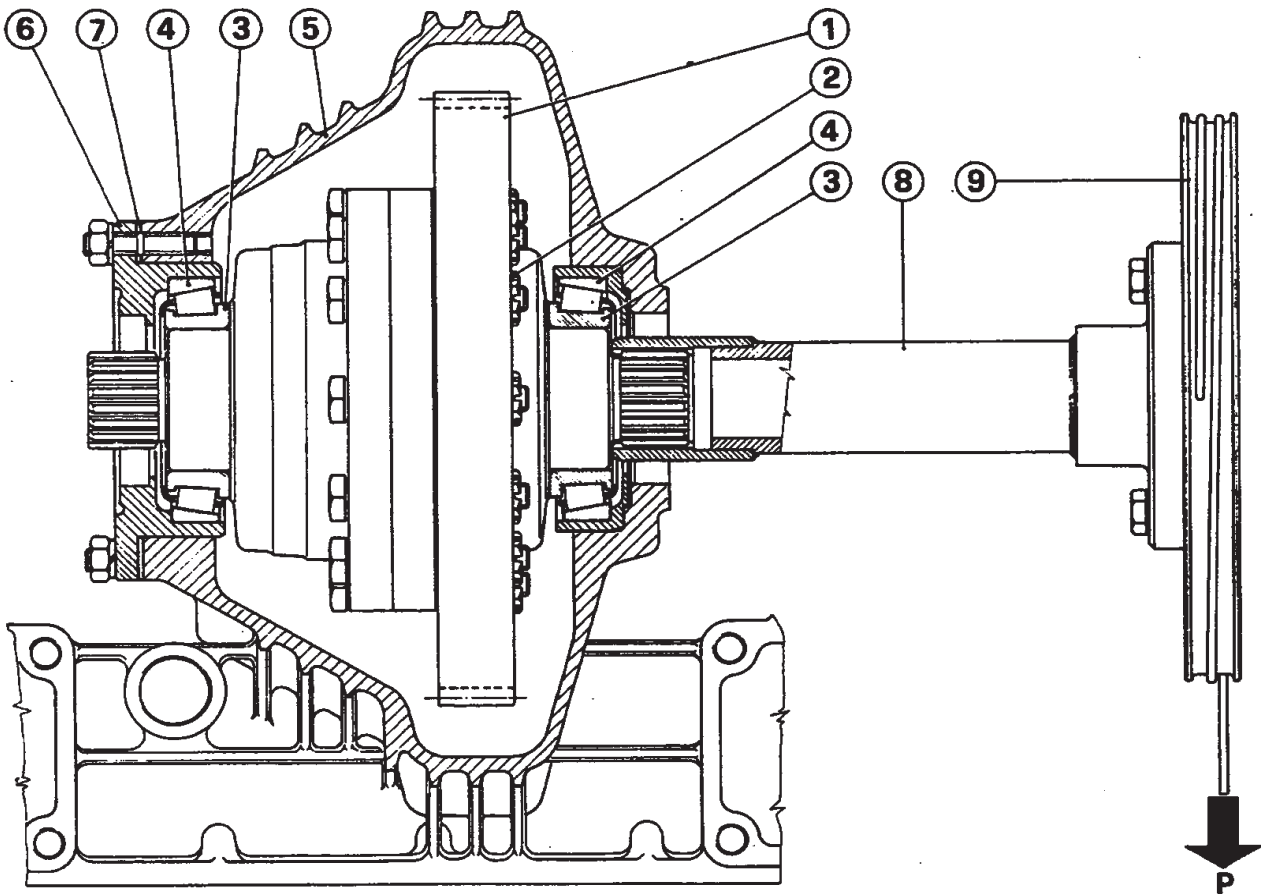

Fig. 13 - BEARINGS PRELOADING.

1 - Crown; 2 - Crown fixing nut; 3 - Roller bearing; 4 - Race for bearing; 5 - Differential case cover; 6 - Lateral cover; 7 - Spacer; 8 - Pulley extension (706-AS-6704); 9 - Preloading pulley (175-AS-5067).

For a good working of taper roller bearings, it is necessary to preload them at the prescribed value during the assembling.

Therefore, carry out the following operations:

- After checking the differential unit, lock the crown (1) on it and tighten the nuts (2) to the prescribed torque.
- Introduce the taper roller bearings (3) on the two extremities using the punch 365-AS-5764. Use the punch 616-AS-8729 to insert the outside races (4) on flange and cover.
- Introduce the complete differential unit in its seat with empty gearbox; block it with cover (5) after spreading the contact surfaces between box and cover with a light layer of Hylomar paste.
- Lubricate the bearings and close the box with the lateral cover (6) introducing previously the spacer (7) fitted in origin.
- On the crown side hub, introduce the extension (8) 706-AS-6704 and relevant pulley \varnothing 200 (9) 175-AS-5067.
- Check the preloading. With new bearings and a load of 2,280+4,030 kg., the pulley should move slowly in a uniform movement. If not, duly vary the spacer (7) thickness until the correct preloading is obtained.

Warning: In case of used bearings, keep the preloading to minimum values.

- Remove the flange (6) and the spacer (7), spread them with Hylomar paste then definitely fit them.
- Remove the extension (8) and fit the two oil rings using the punch 365-AS-5839.
- To end, fit the two side flanges for axle-shafts and block the bolt to the prescribed torque taking care to spread it with a light layer of CAF 4 paste to avoid any possible oil leaks.

AXLE-SHAFTS

The axle-shafts are in one part (LOBRO type) and each one has a universal constant velocity joint containing 140 gr. of MOLICOTE BR 2 grease.

The axle-shafts do not require periodical lubrication. Only in case that the gaiter breaks, have it replaced; then wash the joint and re_u fill it with the prescribed quantity of recommended grease.

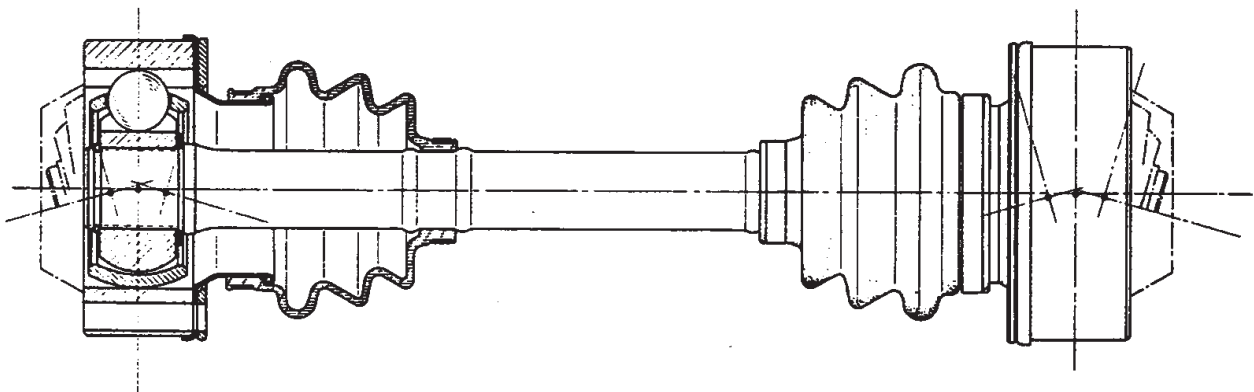

Fig. 14 - AXLE-SHAFT.

CHECKING

If vibrations or noises are noticed on the car rear side, mainly after a long use, check the universal joints.

- If joints present excessive clearances, replace the complete axle-shafts.
- The new axle-shafts do not require balancing.

SECTION **E**

STEERING

	Page
MAIN SPECIFICATIONS	E 3
TROUBLES AND REMEDIES	E 4
STEERING	E 6

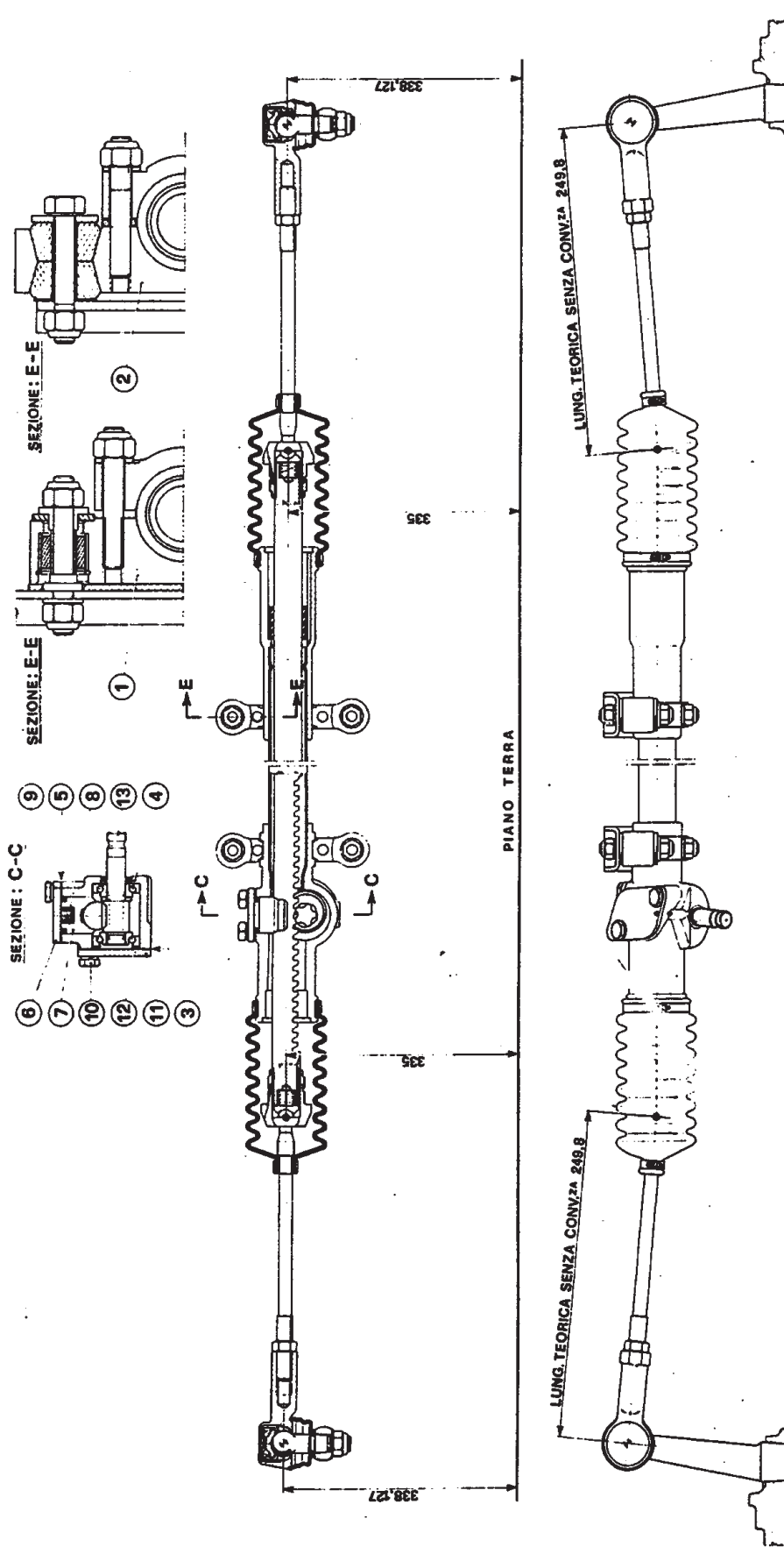

Fig. 1 - STEERING.
1 - Support for steering box (first solution); 2 - Support for steering box (second solution); 3 - Spacer for pinion; 4 - Steering box; 5 - Spacer for rack; 6 - Flange; 7 - Small block; 8 - Spring; 9 - Bolt; 10 - Bolt; 11 - Flange; 12 - Spacer; 13 - Pinion.

S T E E R I N G

MAIN SPECIFICATIONS	Page E 3
TROUBLES DIAGNOSIS AND REMEDIES	" E 4
STEERING	" E 6
GENERAL INFORMATION	" E 6
MAINTENANCE	" E 6

MAIN SPECIFICATIONS

CAM-GEAR steering		Rack and pinion type
Minimum turning circle diameter	m.	12
Steering wheel turns from lock to lock		3,28
Inside wheel steering		$30^{\circ} 30' \pm 30'$
Outside wheel steering		$29^{\circ} \pm 30'$
Control pinion bearings		2 - load and thrust bearings
Pinion axis inclination		$4^{\circ} 5'$
Bearings for rack		1 driving washer 1 adjustable pad
Adjustment of pinion clearance		With spacer
Rack adjustment		With pad, spacer and pressure spring
Lateral tie rods		With ball joints ad justable on rack, ball joints lubricat ed for life on stub axle levers.
Total stroke of rack	mm.	125,5
Steering pinion inclination in relation to the vertical		45°

TROUBLES DIAGNOSIS AND REMEDIES

JERKY STEERING

POSSIBLE CAUSES	REMEDIES
1) Rack slides too freely in box.	1) Adjust rack sliding.
2) Clearance in pinion and rack.	2) Adjust.
3) Clearance in ball joints.	3) Change ball joints on levers. Adjust rack joints.
4) Wheels incorrectly aligned.	4) Check and adjust.
5) Wheels out of balance.	5) Balance wheels.
6) Incorrect tires pressure.	6) Re-set correct tire pressure.
7) Tires irregularly worn or deformed.	7) Check and change tires if necessary.
8) Shock absorbers too stiff.	8) Check setting of shock absorbers.

FRONT WHEEL SHIMMY

POSSIBLE CAUSES	REMEDIES
1) Wheels out of balance (dynamically).	1) Balance wheels.
2) Incorrect tires pressure.	2) Re-set correct pressure.
3) Tires irregularly worn.	3) Replace tires.
4) Clearance in ball joints or in steering.	4) Eliminate clearance.
5) Incorrect alignment of front wheels.	5) Reset correct alignment.
6) Inefficient shock absorbers.	6) Overhaul shock absorbers.
7) Excessive clearance in front wheels bearings.	7) Adjust clearance.
8) Clearance in suspension arms.	8) Overhaul suspension.

SIDE-SKIDDING ON CURVE

POSSIBLE CAUSES	REMEDIES
1) Incorrect tire pressure.	1) Check and reset correct pressure.
2) Tires excessively worn.	2) Replace tires.
3) Wheels out of balance.	3) Reset correct balance.
4) Weak coil springs.	4) Replace coil springs.
5) Inefficient shock absorbers.	5) Check and adjust setting.
6) Inefficient limited slip unit.	6) Overhaul limited slip unit and change discs.
7) Excessive bump on suspension levers.	7) Locate the cause of this inconvenient and remove it.
8) Suspension lever bound.	8) Overhaul levers.

CAR PULLS TO ONE SIDE

POSSIBLE CAUSES	REMEDIES
1) Different pressure between front tires.	1) Reset correct pressure on both tires.
2) Different wearing in front tires.	2) Check but better if both tires are replaced.

CAR PULLS TO ONE SIDE (continuation)

POSSIBLE CAUSES	REMEDIES
3) Incorrect alignment of front or rear wheels.	3) Check and adjust alignment.
4) Irregular clearances in front wheel bearings.	4) Reset prescribed clearances.
5) Deformed coil spring.	5) Check and replace spring.
6) Inefficient shock absorbers.	6) Overhaul shock absorbers.
7) Abnormal contact of brake linings on one wheel with brake pedal in released position.	7) Check the free run of pistons in caliper cylinders.
8) Suspension lever bound.	8) Overhaul suspension assembly.

HARD STEERING

POSSIBLE CAUSES	REMEDIES
1) Too low tire pressure.	1) Tires must be inflated to the prescribed pressure.
2) Incorrect alignment of front wheels.	2) Reset correct alignment.
3) Stiff rack in case.	3) Adjust rack sliding.
4) Stiffness of mainswitch control.	4) Dismantle and check the mating between steering shaft and mainswitch.
5) Stiffness of steering knuckle pins.	5) Replace stiff pins.
6) Stiff joints of rods.	6) Replace lever pins on steering knuckles. Overhaul rack joints.
7) Steering box deformed due to wrong assembly.	7) Check positioning and steering box.

TIRES SQUEAL ON CURVES

POSSIBLE CAUSES	REMEDIES
1) Incorrect tire pressure.	1) Check and inflate tires to correct pressure.
2) Incorrect alignment of front and rear wheels.	2) Check and adjust alignment.
3) Skidding of rear wheels due to tire adhesion limit.	3) Conform car speed to bending radius.

STEERING

GENERAL INFORMATION

Steering of rack type with pinion inclined $4^{\circ} 5'$ and symmetrical lateral control rods independent for each wheel. Ball joints lubricated for life.

MAINTENANCE

If steering box does not show leakages, it is neither necessary to replace the oil nor to top-up level.

- Every 10000 km. check the bellows: if they are in good conditions do not check further the oil level.
- If bellows are leaking, remove them and completely drain the oil from the steering box before refilling with the prescribed quantity of oil.

Steering box spare parts are not available, therefore it is advisable to replace the whole unit in case of damage or overhauling. It is possible, however, to adjust the rack and pinion clearance. Here the relevant instructions:

PINION (Ref. Fig. 1)

Reassemble the pinion in its seat without the spacer 3. Place the flange 11 on the lower bearing and a weight of 10 kg. on the flange. Using a thickness gauge, check the gap between guide 4 and flange 11 then fit a spacer $0,05 + 0,13$ mm. higher than the gap. Reassemble the flange and the spacer and seal with a jointing compound to avoid oil leakages then lock the bolts 10. The pinion should run freely without axial play.

RACK

Introduce the rack, in normal operating position, into the steering box well lubricated; introduce also the pressure pad 7 without the springs 8, put the flange 6 on the pressure pad but without spacer 5 then gradually tighten the bolts 9 until the pinion can move 180° in the two directions with a slight effort. With a thickness gauge, measure the gap between steering box 4 and flange 6 then fit a shim of $0,05 + 0,13$ mm. higher than the gap. Fit again the springs 8 in pad 7, the spacer 5 with jointing compound and lock the flange 6. Check that pinion 13 can run in the two directions without stiffness.

SECTION **F**

FRONT
SUSPENSION

	Page
GENERAL INFORMATION	F 3
MAIN SPECIFICATIONS	F 3
TROUBLES AND REMEDIES	F 4
CHECKING SUSPENSION COMPONENTS	F 7
CHECKING AND ADJUSTING CLEARANCE OF TAPER ROLLER BEARINGS	F 8
CHECKING AND ADJUSTING FRONT WHEELS ALIGNMENT	F 8

FRONT SUSPENSION

GENERAL INFORMATION Page F 3
 MAIN SPECIFICATIONS " F 3
 TROUBLES DIAGNOSIS AND REMEDIES " F 4
 CHECKING SUSPENSION COMPONENTS. " F 7
 FLEXIBLE BUSHINGS CONNECTING WISHBONES TO CHASSIS " F 7
 BALL JOINTS FOR STEERING KNUCKLES " F 7
 CHECKING AND ADJUSTING CLEARANCE OF WHEEL TAPER ROLLER BEARINGS F 8
 CHECKING AND ADJUSTING WHEELS SETTING " F 8
 CAMBER ANGLE " F 9
 TOE-IN " F 9
 CASTER ANGLE " F10
 KINGPIN ANGLE " F10

GENERAL INFORMATION

Independent wheel suspension with lower and upper wishbones. Coil springs, telescopic hydraulic shock absorbers (double acting) with rubber rebound bumpers.
 Transversal stabilizer bar.
 The flexible bushings, connecting wishbones to chassis, do not require any lubrication.

MAIN SPECIFICATIONS

Type	Independent wheels with hydraulic shock absorbers and coil springs.
Stabilizer bar	Transversal, fitted on rubber pads
Diameter	mm. 18
Upper and lower wishbones	
Connection to chassis	By forks and flexible bushings
Connection to steering knuckle	By articulated balls lubricated for life
Setting data	
Camber angle (*)	Min. +0° 10' + Max.+0° 30'
Adjustment of wheel camber	By shims
Toe-in (*)	1 ÷ 3 mm.
Toe-in adjustment	Operating on steering rod length
Kingpin angle	9° 30'
Caster angle	4°
Caster angle adjustment	By shims

Wheel bearings Bearing axial play Bearings lubrication	Taper roller type mm. 0,06 + 0,10 AGIP F1 33FD
(* Car in static load conditions	Full of fuel, 2 persons and 20 kg. of luggage.
Suspension springs Free length of spring Static load Spring length under static load Wire diameter Inner diameter Flexibility Helical direction Total spring turns WARNING - The springs are graded according to their load and are marked by different coloured turns. The assembling must be done with matched springs having equal reference. Shock absorbers Type	mm. 349 kg. 450 mm. 205 mm. 12,5 mm. 77,5 mm./kg. 0,32 Right Nt. 12,75 KONI 82x - 1830

TROUBLES DIAGNOSIS AND REMEDIES

WHEEL TRAMP

POSSIBLE CAUSES	REMEDIES
1) Tire irregularly worn due to strong brakings.	1) Replace tire.
2) Different tire pressure.	2) Check and correctly inflate tyres.
3) Wheels out of balance.	3) Check and reset balance.
4) Weak coil springs.	4) Replace coil springs.
5) Ineffective shock absorbers.	5) Check operation of shock absorbers on special fixture and overhaul it.

EXCESSIVE TIRE WEAR

POSSIBLE CAUSES	REMEDIES
1) Incorrect camber angle.	1) Check angle and adjust.
2) Incorrect toe-in.	2) Check toe-in and adjust.
3) Incorrect tire pressure.	3) Check and inflate tires to correct pressure.
4) Too fast acceleration.	4) Acceleration must be progressive.
5) High speeds on bad road surface.	5) On this type of road speed should be moderate.
6) Excessive bearing clearance.	6) Adjust clearance and lubricate bearings with AGIP F1 33 FD grease.
7) Wheel shimmy.	7) Find cause of shimmy.
8) Excessive use of brakes.	8) Reduce use of brakes.
9) Excessive skidding on curves.	9) Reduce speed when curving.

NOISY SUSPENSION

POSSIBLE CAUSES	REMEDIES
<ol style="list-style-type: none"> 1) Shock absorbers noisy or ineffective. 2) Levers flexible bushings are worn. 3) Worn ball joints. 4) Bearings worn or with excessive clearance. 	<ol style="list-style-type: none"> 1) Overhaul shock absorbers. 2) Replace flexible bushings. 3) Replace ball joints. 4) Check bearings for efficiency, change parts where necessary and refit, lubricating with AGIP F1 33 FD grease

CAR PULLS TO ONE SIDE

POSSIBLE CAUSES	REMEDIES
<ol style="list-style-type: none"> 1) Tire pressure low or incorrect. 2) Front wheel setting incorrect. 3) Incorrect clearance in front wheel bearings. 4) Ineffective shock absorbers. 5) Weak coil spring. 6) Brakes binding on one wheel. 7) Incorrect parallelism in front and rear axles. 	<ol style="list-style-type: none"> 1) Check and inflate tires to correct pressure. 2) Check and adjust wheel setting. 3) Adjust clearance. 4) Remove and overhaul shock absorbers. 5) Replace faulty spring. 6) Check brakes. 7) Check.

WHEEL SHIMMY

POSSIBLE CAUSES	REMEDIES
<ol style="list-style-type: none"> 1) Unequal tire pressure. 2) Wheel bearings worn or loose. 3) Ineffective shock absorbers. 4) Incorrect wheel setting. 5) Levers flexible bushings are worn. 6) Wheels out of balance. 	<ol style="list-style-type: none"> 1) Inflate tires correctly. 2) Dismantle and change faulty parts. 3) Overhaul shock absorbers. 4) Check and adjust. 5) Check and replace them. 6) Check and balance.

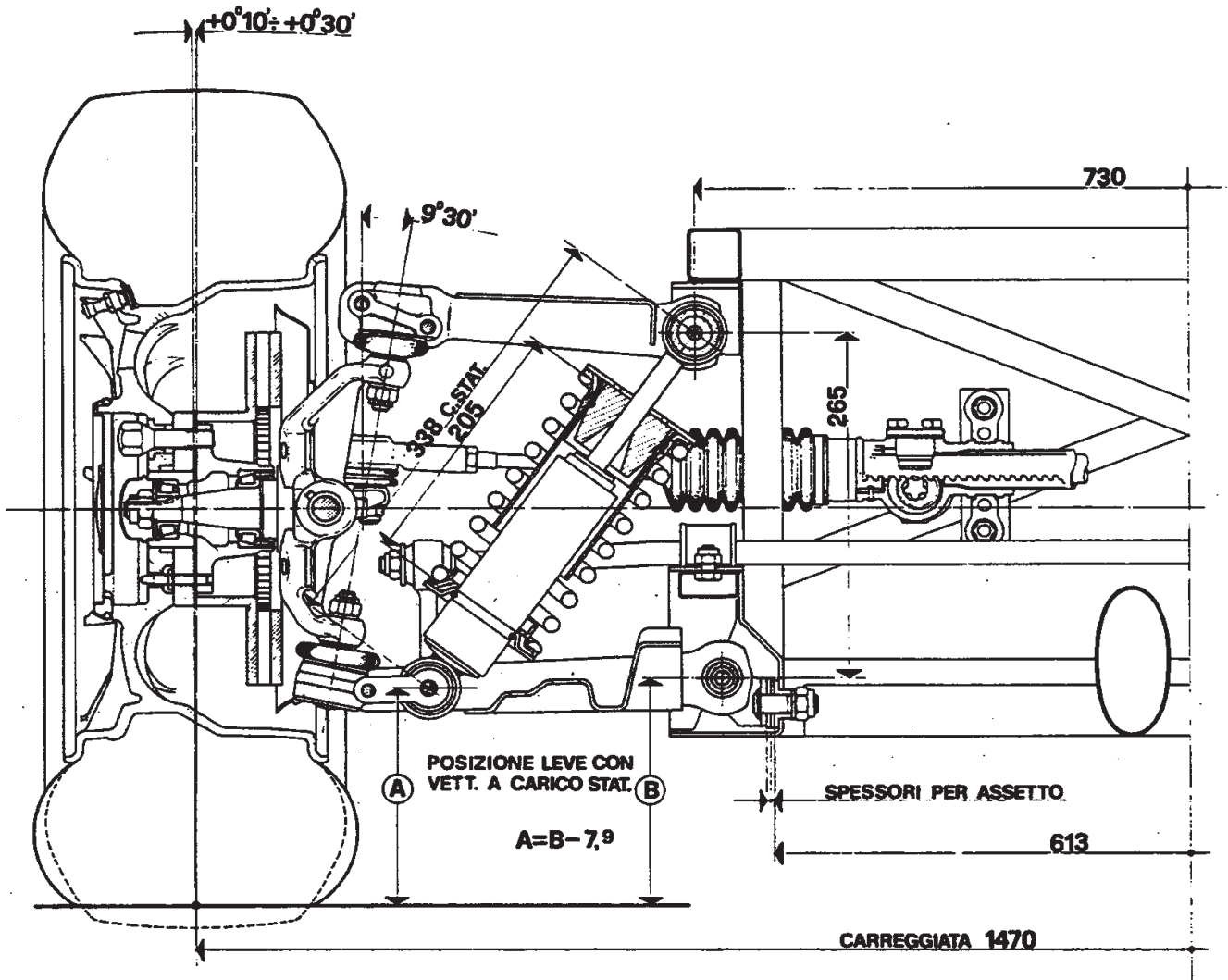

Fig. 1 - CROSS SECTION THROUGH WHEEL and FRONT SUSPENSION

CHECKING SUSPENSION COMPONENTS

- Check axial and radial plays of pins connecting wishbones to forks. Replace the bushes in case of excessive play.
- Make sure of shock absorbers efficiency; reset the prescribed value.
- Check the rubber bushing of shock absorbers upper and lower connections.
- Make sure of rubber rebound bumpers efficiency (on shock absorbers)
- Check stabilizer bar alignment, the efficiency of rubber supports.
- Check wheel hub roller bearings and replace them if races and rollers are not in good conditions: rolling roughness or noise are not acceptable.
- Check the oil seal for roller bearings on steering knuckle: it is advisable to replace it when it is removed.
- Check steering knuckle pin: it should not present wearing on bearing seats and on nut threading.
- Check that wishbones do not present deformation.
- Check ball joint rubber gaiters for efficiency.
- Check coil springs making reference to the table of page F 4: make sure that they are not deformed and do not present scratches.
- Make sure that the two springs have the first coil with same color.

FLEXIBLE BUSHINGS CONNECTING WISHBONES TO CHASSIS

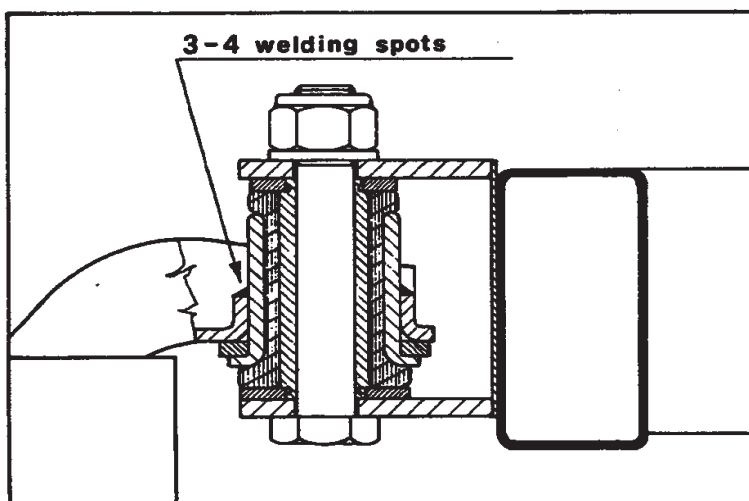

Fig. 2 - FLEXIBLE BUSHINGS CONNECTING WISHBONES TO CHASSIS.

Suspension arms are connected to chassis forks by FLANBLOC flexible bushings. Replace the complete bushing in case of excessive wear or deformation. When re-fitting the bushing, drive it on the arm then block further on by two electric spot-weldings.

Warning: Though the aforementioned bushings are geometrically equal to those of the rear suspension, they differ from these in hardness and colour: green rubber for front suspension and red rubber for rear suspension.

BALL JOINTS FOR STEERING KNUCKLES

Ball joints, lubricated for life, do not require any maintenance service. Only in case of excessive play they must be replaced.

CHECKING AND ADJUSTING TAPER ROLLER BEARINGS

To get the bearings axial play, keep to the following instructions:

- Apply the magnetic bracket (3) on the caliper; put the tracer point (1) in contact with brake disc then set the dial gauge index to zero.
- Remove brake pads from caliper and check the index movement by making the brake disc move in axial way.
- The prescribed clearance should be within 0,06 and 0,10 mm. In case the value is higher or lower than the prescribed one, loosen or tighten the nut of 1/12 of a turn then check again. After adjusting, caulk the nut.

If caulking reaches the originally punched area, replace the nut. Make sure that there are no grease leakages from wheel hub oil seal.

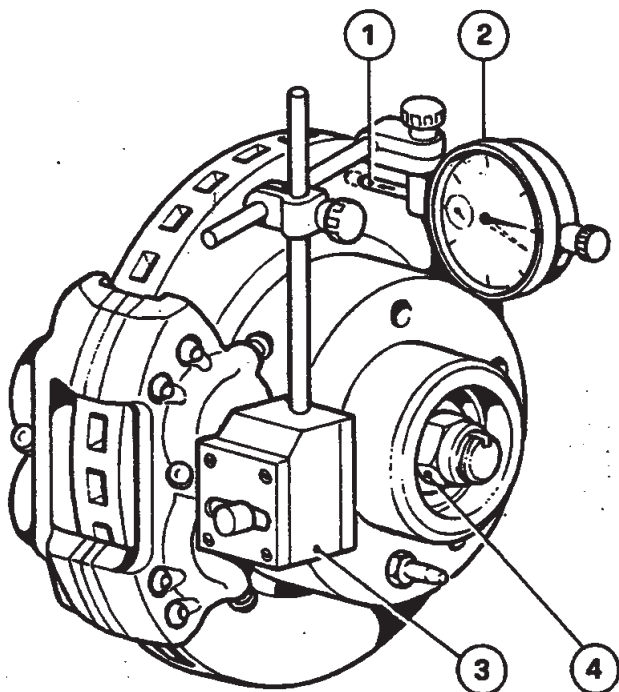

Fig. 3 - CHECKING AXIAL PLAY of TAPER ROLLER BEARINGS.

1 - Tracer point; 2 - Dial gauge;
3 - Magnetic bracket; 4 - Nut.

In case that bearings need to be replaced, act as follows:

- With a dynamometric wrench tighten to kgm. 2,5 the nut on steering knuckle pin and, at the same time, rotate the hub for some turns in the two directions.

- Loosen completely the nut then re-tighten it to kgm. 1,5.

The resulting axial play should be as near as possible to 0,06 mm., not less.

The maximum play should not exceed 0,10 mm.

- Carefully caulk the lock nut.

Introduce in advance gr. 120 of AGIP F1 33 FD grease in the space between the two bearings; grease should be spread on the hub inner surface.

CHECKING AND ADJUSTING WHEEL SETTING

Before the inspections, carefully check some suspension components which could affect the car setting; in case that some irregularities arise, remove them thus avoiding any wrong surveys.

Effect the subsequent inspections:

- Tire pressure.
- Front roller bearings for play.
- Steering rack and pinion for clearance.
- Steering rod ball pins for play.
- Hydraulic shock absorbers efficiency.
- Clearance between steering knuckle and ball pins.

Set the car in a horizontal plane and under static load then check the correct position of levers.

CAMBER ANGLE

The camber angle must be within the minimum value of $+ 0^{\circ}10'$ and the maximum value $+ 0^{\circ}30'$. In case that wheel camber angle does not correspond to the aforementioned values, effect the adjustment varying the quantity and thickness of washers placed between chassis lower wishbones forks and the chassis.

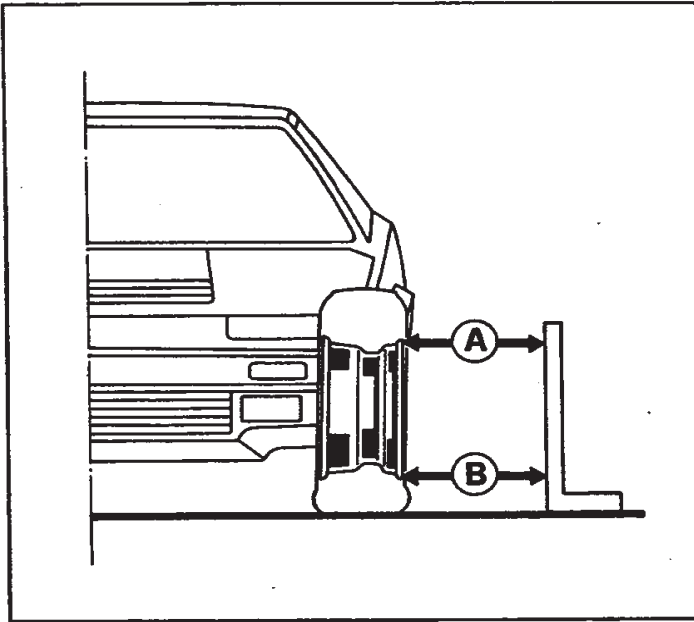

Fig. 4 - FRONT WHEEL CAMBER.
A = B - 1 mm. min. value.
A = B - 3,25 mm. max. value.

TOE-IN

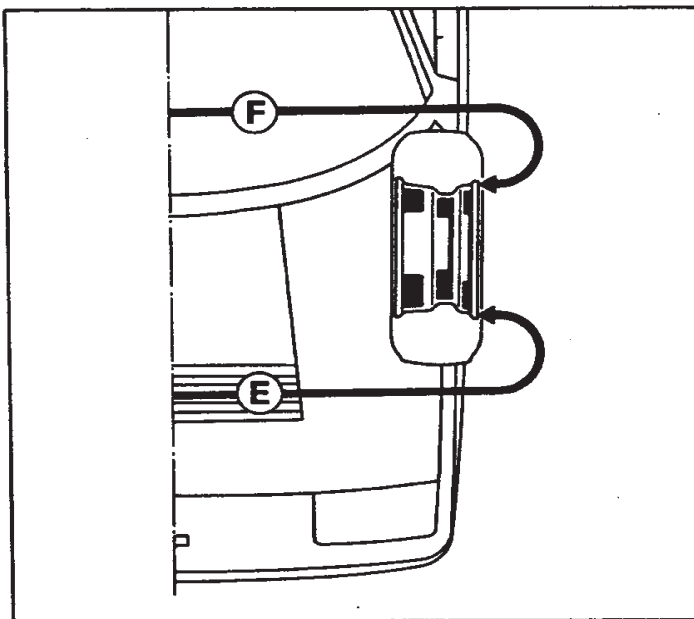

Fig. 5 - FRONT WHEEL TOE-IN.
E = F - 1 mm. min. value.
E = F - 3 mm. max. value.

In case that the toe-in value is not within 1 → 3 mm., act as follows. Make sure that the steering box is in central position and steering wheel is exactly in horizontal position: in this way the two lateral tie rods should be equal in length. If not, adjust them. Loosen the lock nuts of tie rod ball joints; vary the tie rods length until the exact toe-in is achieved. Re-tighten the lock nuts.

CASTER ANGLE

To check the caster angle use one of the suitable tool and follow the relevant instructions.

The caster angle is $4^{\circ} \pm 20'$.

If not, operate on the plates 1 (fig. 6) moving some of them from side to side of the suspension arms until the correct value is obtained.

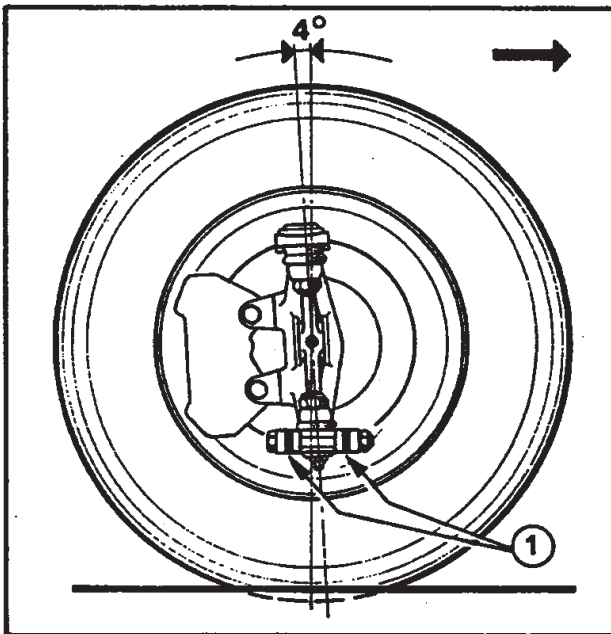

Fig. 6 - CASTER ANGLE.

KINGPIN ANGLE

The kingpin angle cannot be adjusted.
Kingpin value is $9^{\circ}30'$.

SECTION **G**

REAR
SUSPENSION
HYDRAULIC
SHOCK ABSORBERS

	Page
REAR SUSPENSION	G 3
GENERAL INFORMATION	G 3
MAIN SPECIFICATIONS	G 3
TROUBLES AND REMEDIES	G 4
CHECKING AND ADJUSTING WHEELS ALIGNMENT	G 5
HYDRAULIC SHOCK ABSORBERS	G 7
MAIN SPECIFICATIONS	G 7
TROUBLES AND REMEDIES	G 8
GENERAL INFORMATION	G 8
OPERATING INFORMATION	G 8
SETTING	G 11

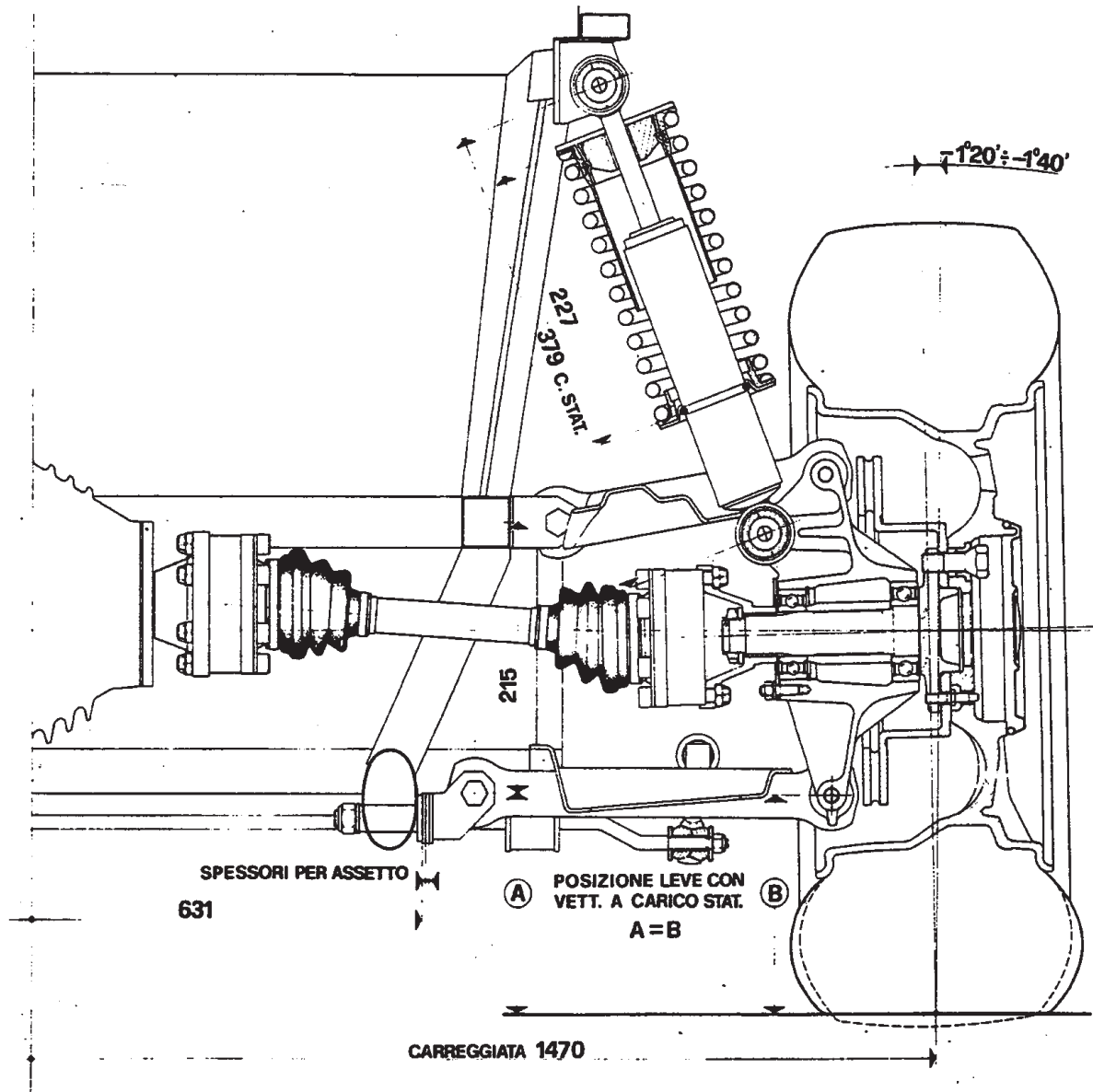

Fig. 1 - CROSS SECTION THROUGH WHEEL and REAR SUSPENSION

R E A R S U S P E N S I O N

GENERAL INFORMATION	Page G 3
MAIN SPECIFICATIONS	" G 3
TROUBLES DIAGNOSIS AND REMEDIES	" G 4
WHEEL SHAFT	" G 5
SUSPENSION ARMS	" G 5
CHECKING AND ADJUSTING WHEEL SETTING.	" G 5
CAMBER ANGLE	" G 6
TOE-IN	" G 6

GENERAL INFORMATION

Independent wheel suspension with lower and upper wishbones. Coil springs, telescopic hydraulic shock absorbers (double acting) and transversal stabilizer bar.

The wishbones are connected to the hub carrier by bearings with special bushings which do not require lubrication and are connected to the chassis by forks and rubber flexible bearings.

The wheel shaft, in one piece with the hub, is supported by two ball bearings.

The transversal stabilizer bar is connected to the chassis by two rubber supports; the two extremities are articulated to the suspension lower arms by proper rubber shackles with rubber bushings and rings.

MAIN SPECIFICATIONS

Type	Independent wheels with coil springs and hydraulic shock absorbers.
Stabilizer bar	Transversal, fitted on rubber pads
Diameter	mm. 11,5
Upper and lower wishbones	
Connection to chassis	By forks and flexible bearings (Fland Block)
Connection to levers mounting	By flexible bushings - self-lubricating type
Wheels	
Camber angle (*)	Min. $-1^{\circ}20'$ + Max. $-1^{\circ}40'$
Camber angle measured on wheel rim	Min. mm. 8,6+Max.mm.10,75
Adjustment of wheel camber	By shims
Toe-in (*)	mm. 2 + 4
Toe-in adjustment	By shims
(*) Car in static load conditions	Full of fuel + 2 persons and 20 kg. of luggage.

Suspension springs	
Free length of spring	mm. 344
Static load	kg. 390
Spring length under static load	mm. 227
Wire diameter	mm. 12,5
Inner diameter	mm. 77,5
Flexibility	mm.kg. 0,3
Helical direction	Right
WARNING - The springs are graded according to their load and are marked by different coloured turns. The assembling must be done with matched springs having equal reference.	
Shock absorbers	KONI 82x - 1831

TROUBLES DIAGNOSIS AND REMEDIES

SQUEAKS, KNOCKS or OTHER NOISES

POSSIBLE CAUSES	REMEDIES
1) Wheels out of balance.	1) Check and adjust.
2) Wheels out of center.	2) Check and adjust.
3) Noisy differential.	3) Refer to relevant section where possible causes and remedies are listed.
4) Worn shock absorbers which fail to operate.	4) Overhaul shock absorbers or replace them.
5) Coil spring weak or broken.	5) Replace spring.
6) Bushings of upper and lower levers are worn.	6) Check and replace worn parts.

IRREGULAR or EXCESSIVE TIRE WEAR

POSSIBLE CAUSES	REMEDIES
1) Wrong tire pressure.	1) Check and correct pressure.
2) Wheels out of balance.	2) Check and adjust.
3) Wheels out of center.	3) Check and adjust.
4) Incorrect camber angle.	4) Check and adjust camber.
5) Incorrect toe-in.	5) Check toe-in.

CAR PULLS to ONE SIDE

POSSIBLE CAUSES	REMEDIES
1) Incorrect pressure in one tire.	1) Check and correctly inflate tires.
2) Incorrect suspension setting.	2) Check wheel setting and make sure of suspension arms efficiency.
3) One wheel still braking even after brake release.	3) Check brake operating on the four wheels.
4) Spring weak or broken.	4) Replace spring.

WRONG SUSPENSION SETTING on ONE WHEEL

POSSIBLE CAUSES	REMEDIES
1) Wrong pressure in one tire. 2) Coil spring weak or broken. 3) Shock absorber fails to operate.	1) Check and inflate tires to the correct pressure. 2) Replace spring. 3) Overhaul shock absorber and change worn parts.

WHEEL SPINDLE

Check ball bearings for play and noise. Since the bearings are air-tight type, they do not need any periodical lubrication. The condition of balls and races cannot be easily checked, therefore it is advisable to replace them when the car has been driven for 40000 + 50000 km. even if they do not present noises or play.

SUSPENSION CONTROL ARMS

CHECKINGS

- Check shock absorber calibration and provide the specified adjustment if necessary.
- Check silent-block mountings and grommets on spring retaining flanges.
- Check the conditions of rubber rebound bumpers on shock absorbers.
- Check suspension springs in relation to the characteristics data indicated in table and make sure that the coloration is the same for both coils.
- Check bushing clearance on both ends of control arms and replace if worn.
- Check shim clearance.
- Check grommets and dust seals.
- Check the alignment of stabilizer bar and play of supports.
- Check bar link rubber buffers and lower control arm silent-blocks.

CHECKING AND ADJUSTING WHEEL SETTING

Before the inspections, carefully check some suspension components which could affect the car setting; in case that some irregularities arise, remove them thus avoiding any wrong surveys.

Effect the subsequent inspections:

- Tire pressure.
- No play in suspension arms.
- Shock absorbers are effective.
- Suspension springs are not deformed.

Set the car in a horizontal plane and under static load then check the levers correct position.

CAMBER ANGLE

The camber angle must be within the minimum value of $-1^{\circ}20'$ and the maximum value of $-1^{\circ}40'$.

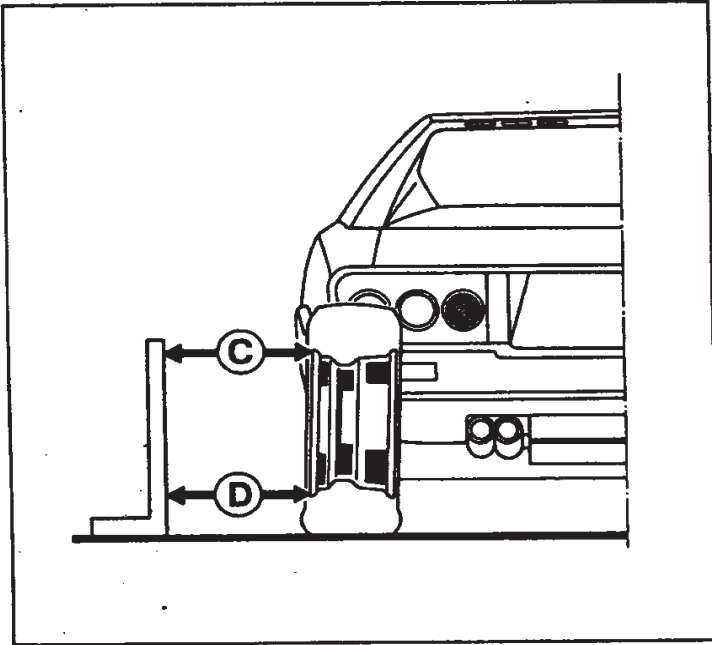

Fig. 2 - REAR WHEEL CAMBER.
 $C = D + 8,6$ mm. min. value.
 $C = D + 10,75$ mm. max. value.

In case that the camber angle is not within the prescribed values, vary the quantity or the thickness of the washers placed between the chassis lower wishbones forks and the chassis.

TOE-IN

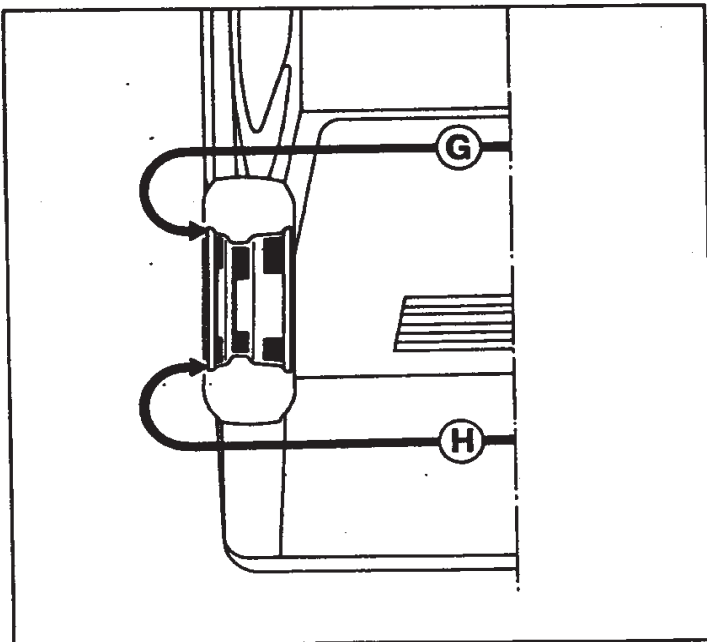

Fig. 3 - REAR WHEEL TOE-IN.
 $G = H - 2$ mm. min. value.
 $G = H - 4$ mm. max. value.

In case that toe-in is not within the prescribed values, operate on the front forks of both suspension control arms then duly vary the thickness or quantity of the washers.

HYDRAULIC SHOCK ABSORBERS

MAIN SPECIFICATIONS Page G 7
 TROUBLES DIAGNOSIS AND REMEDIES " G 8
 GENERAL INFORMATION " G 8
 OPERATING INFORMATION " G 8
 COMPRESSION TRAVEL " G 8
 EXPANSION TRAVEL " G10
 SHOCK ABSORBERS SETTING " G11

MAIN SPECIFICATIONS

FRONT	
Type	KONI 82x - 1830
Shock absorber compression travel	mm. 50
Shock absorber return travel	mm. 48
Rating - Expansion	kg. 110
Rating - Compression	kg. 30
Oil capacity	lt. 0,190
Type of oil	AGIP OSO 35
REAR	
Type	KONI 82x - 1831
Shock absorber compression travel	mm. 74
Shock absorber return travel	mm. 73
Rating - Expansion	kg. 130
Rating - Compression	kg. 25
Oil capacity	lt. 0,310
Type of oil	AGIP OSO 35

CAMBER ANGLE

The camber angle must be within the minimum value of $-1^{\circ}20'$ and the maximum value of $-1^{\circ}40'$.

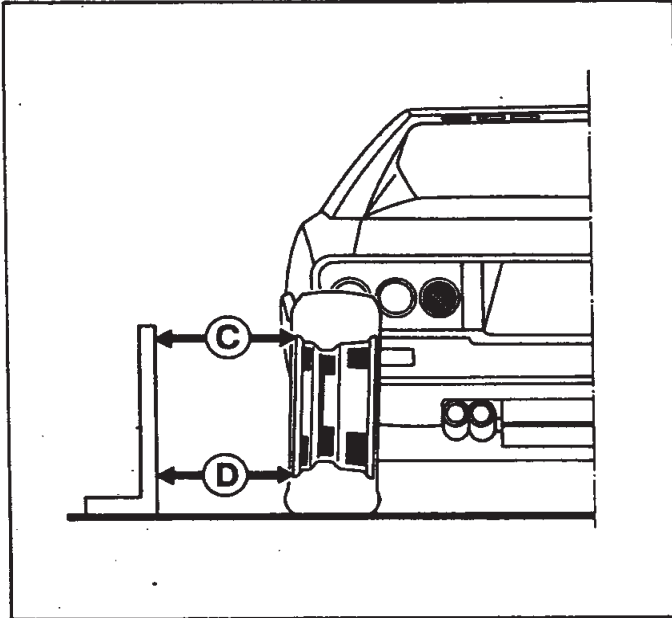

Fig. 2 - REAR WHEEL CAMBER.
 $C = D + 8,6$ mm. min. value.
 $C = D + 10,75$ mm. max. value.

In case that the camber angle is not within the prescribed values, vary the quantity or the thickness of the washers placed between the chassis lower wishbones forks and the chassis.

TOE-IN

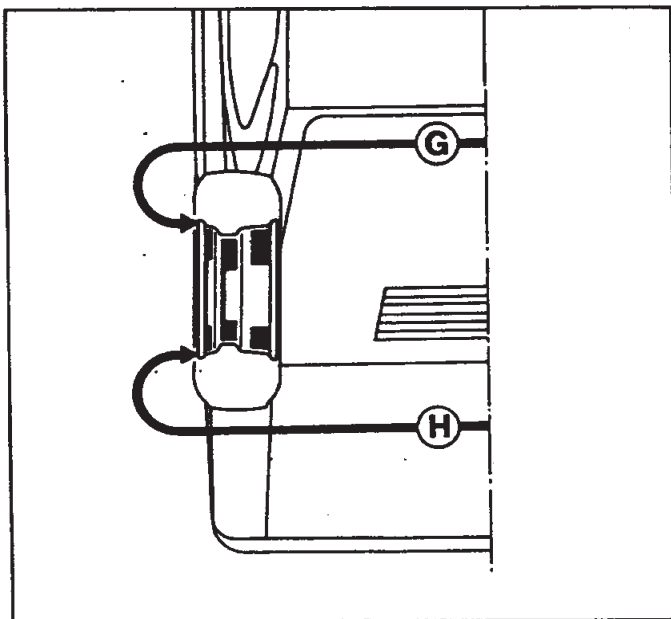

Fig. 3 - REAR WHEEL TOE-IN.
 $G = H - 2$ mm. min. value.
 $G = H - 4$ mm. max. value.

In case that toe-in is not within the prescribed values, operate on the front forks of both suspension control arms then duly vary the thickness or quantity of the washers.

HYDRAULIC SHOCK ABSORBERS

MAIN SPECIFICATIONS Page G 7
 TROUBLES DIAGNOSIS AND REMEDIES " G 8
 GENERAL INFORMATION " G 8
 OPERATING INFORMATION " G 8
 COMPRESSION TRAVEL " G 8
 EXPANSION TRAVEL " G10
 SHOCK ABSORBERS SETTING " G11

MAIN SPECIFICATIONS

FRONT	
Type	KONI 82x - 1830
Shock absorber compression travel	mm. 50
Shock absorber return travel	mm. 48
Rating - Expansion	kg. 110
Rating - Compression	kg. 30
Oil capacity	lt. 0,190
Type of oil	AGIP OSO 35
REAR	
Type	KONI 82x - 1831
Shock absorber compression travel	mm. 74
Shock absorber return travel	mm. 73
Rating - Expansion	kg. 130
Rating - Compression	kg. 25
Oil capacity	lt. 0,310
Type of oil	AGIP OSO 35

TROUBLES DIAGNOSIS AND REMEDIES

NOISY OPERATION

POSSIBLE CAUSES	REMEDIES
1) Deterioration of upper or lower connections.	1) Inspect rubber bushes; if these are damaged or hard, change them.
2) Lack of oil due to leakage.	2) Overhaul shock absorber and refill with quantity of oil given on page G 7.
3) Buffer damaged or hard.	3) Replace buffer.
4) Piston rod hardened in the seal rubber washers.	4) Lubricate piston rod.

VARIATIONS in DAMPING ACTION

POSSIBLE CAUSES	REMEDIES
1) Increased damping due to oil changes.	1) Check oil which in this case will be too dense. Refill with oil of the prescribed type.
2) Reduction in damping action due to breakage of parts or to some weak valve springs.	2) Overhaul shock absorber then make necessary changes.
3) Reduction in damping action due to lack of oil.	3) Refill with the prescribed type of oil.

GENERAL INFORMATION

The hydraulic shock absorbers (Model KONI), both front and rear, are double acting, telescopic type. They consist of a cylindrical shaped body, formed by two co-axial tubes in which the inner tube (17) is the main cylinder, while the outer tube (18) encloses the compensating reservoir.

Two flanges 22-28 are placed on the pipe 18 lower part and on the stem 16 upper part. These flanges support the suspension springs on which two rubber spacers 24-25 are fixed to avoid spring noise.

The cylinder body 17 is closed on the top end by a lock nut which is screwed on pipe 18 against balance valves 5-26 seat 4 on the pipe bottom. The lock nut is provided with three rubber rings where the piston rod slides through. The piston rod carries the chassis mounting on the upper end and on the lower end the piston 12 with the shut-off valve 13 and the expansion valve 11. On the piston rod 16 are placed the rubber rebound bumper 23 and the flexible washer 30 which limit the compression travel of the shock absorbers.

Inside cylinder 17 there is also the rubber rebound bumper 29 which limits the return travel (expansion).

OPERATING INFORMATION

COMPRESSION TRAVEL

Imagine, for clarifying purpose, a rebounding wheel and the chassis in complete arrest position. It occurs that for each ground contact the wheel will receive an impact upwards thus dragging the part of shock absorber fixed to the suspension arm. This impact is snubbed

partly by the suspension flexibility and partly from the shock-absorber action during the compression travel.

Due to this displacement, a compression chamber is formed under the piston and a vacuum above the piston. Under this condition, the shut-off valve 13 will open and the fluid will flow through the holes D provided in the piston and pass into the upper chamber. Other fluid will also move through the registered holes C and the radial hole A, into the upper chamber.

Since the upper chamber cannot receive all the fluid which is expelled from the compression chamber, because of the volume occupied by the piston rod, then the valve 5, located on the cap at the lower end of cylinder 17, will open thus allowing the excess fluid to flow through the filter and plug channels into the reservoir chamber 18.

The resistance opposed to the fluid passing through valve 5, sets up the absorbing power of the unit.

- I [diagonal lines] OIL UNDER PRESSURE
- II [horizontal lines] OIL AT REST

Fig. 4 - COMPRESSION TRAVEL OPERATION.

- A - Radial hole.
- B - Axial hole.
- C - Registered holes.
- D - Relief holes.
- E - Two-way holes.
- 4 - Valve seat.
- 5 - Compensating valve.
- 8 - Lock bolt.
- 9 - Register nut.
- 10 - Spring.
- 11 - Expansion valve.
- 12 - Piston.
- 13 - Shut-off valve.
- 16 - Piston rod.
- 17 - Pressure cylinder.
- 18 - Oil reservoir.
- 19 - Lock pin.
- 20 - Upper connection.
- 21 - Flanges.
- 22 - Flange for spring.
- 23 - Compression rebound bumper.
- 24 - Rod protection cylinder.
- 25 - Spring lower spacer.

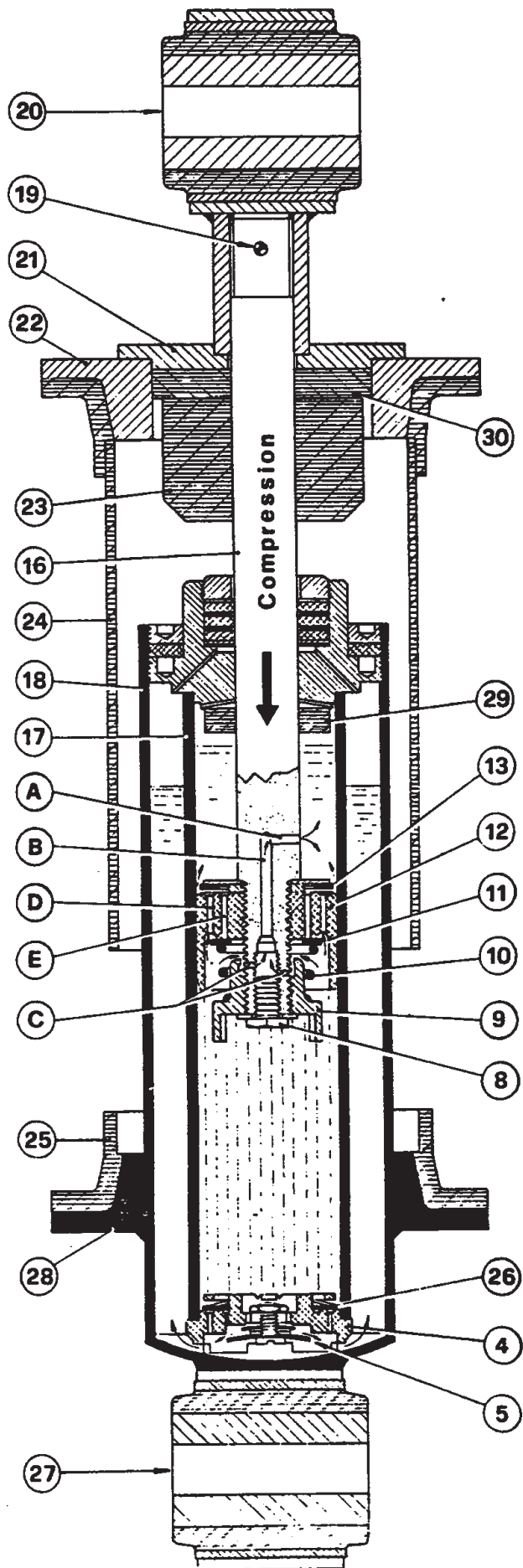

- 26 - Compensating valve.
- 27 - Lower connection.
- 28 - Flange for spring.
- 29 - Expansion rebound bumper.
- 30 - Rubber washer.

RETURN TRAVEL (EXPANSION)

When the wheel, previously in motion, has obtained its normal position due to the brake action, it draws at the same time the shock absorber body, while piston 12 remains in place, forming therefore a compression chamber. This function will cause the shut off valve 13 to close and part of the fluid to flow into the lower chamber through the holes A-B-C. The excess fluid passes through holes E of piston 12, reaches valve 11 and causes it to open by overcoming the spring pressure 10. At the same time, more fluid enters into cylinder 17 through valve 26 until it is entirely full as a result of the vacuum formed in the lower chamber under piston 12.

The resistance opposed to the fluid through piston holes E, that created on valve 11 by spring 10 and the resistance of the registered holes C, provide the absorbing pressure on the return travel of the unit.



-  OIL UNDER PRESSURE
-  OIL AT REST

Fig. 5 - RETURN TRAVEL (EXPANSION)

- A - Radial hole.
- B - Axial hole.
- C - Registered holes.
- D - Relief holes.
- E - Two-way holes.
- 4 - Valve seat.
- 5 - Compensating valve.
- 8 - Lock bolt.
- 9 - Register nut.
- 10 - Spring.
- 11 - Expansion valve.
- 12 - Piston.
- 13 - Shut-off valve.
- 16 - Piston rod.
- 17 - Pressure cylinder.
- 18 - Oil reservoir.
- 19 - Lock pin.
- 20 - Upper connection.
- 21 - Flange.

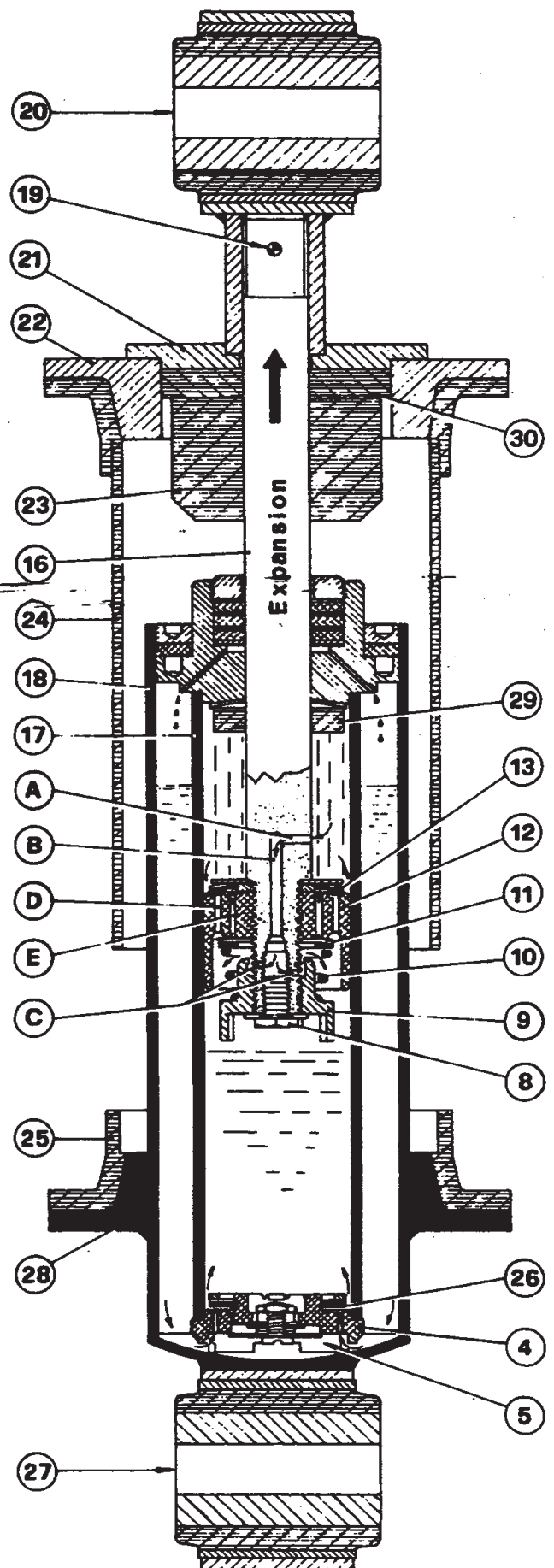

- 22 - Flange for spring.
- 23 - Compression rebound bumper.
- 24 - Rod protection cylinder.
- 25 - Spring lower spacer.
- 26 - Compensating valve.
- 27 - Lower connection.
- 28 - Flange for spring.
- 29 - Expansion rebound bumper.
- 30 - Rubber washer.

SHOCK ABSORBERS SETTING

The shock absorbers are rated according to the data indicated in the rating diagrams Figures 6 and 7.

The instructions described below refer therefore to the adjustment of shock absorbers in case of inefficient conditions or even when it is desired to provide either a more rigid or a more flexible suspension.

The setting operation will be effected as follows:

- Remove shock absorber from car.
 - Remove the spring and items 24 - 25.
 - Fasten the shock absorber on a bench vice and block it to the lower connection 27.
 - Remove the lock pin 19.
 - Holding the piston rod 16 steady, unscrew the upper connection 20.
 - Remove the rubber rebound bumper 23.
 - Reassemble temporarily the upper connection 20 and fasten it on a bench vice; press the shock absorber completely making it rotate slowly counterclockwise until the register nut tooth 9 engages in the groove of seat 4. Maintain rotation without forcing until encountering the resistance against the lock bolt 8.
- Do not force any further to avoid damage to the unit.

At this point, the fluid is free to move through valve 11 and the holes C, so the shock absorber should operate with extreme flexibility. Maintaining a constant pressure, rotate the shock absorber two half-turns clockwise.

Raise the upper connection 20 at least 1 cm., without turning it, in order to release the engaging tooth 9.

The shock absorber is now practically re-rated for normal operation. However, for getting an exact rating, it is essential to use the suitable machine. The total adjustment range allowed is six half-turns to the right: in this condition, the shock absorber should attain the maximum rigidity.

It is recommended to avoid any extension or compression whilst the shock absorber is in horizontal position.

DIAGRAMS ACHIEVED BY GMF MACHINE - TRAVEL 75 mm. - ARM LENGTH mm. 180

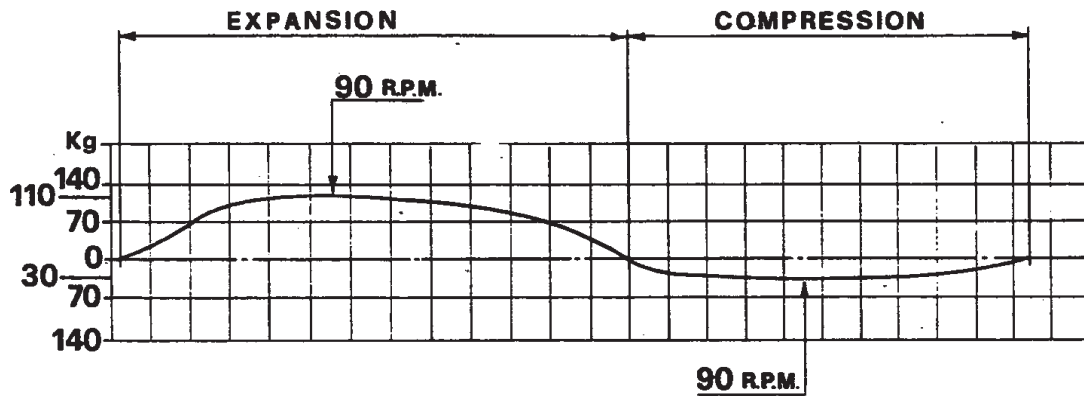

Fig. 6 - FRONT SHOCK ABSORBERS. RATING DIAGRAM:
EXPANSION Kg. 110 - COMPRESSION Kg. 30.

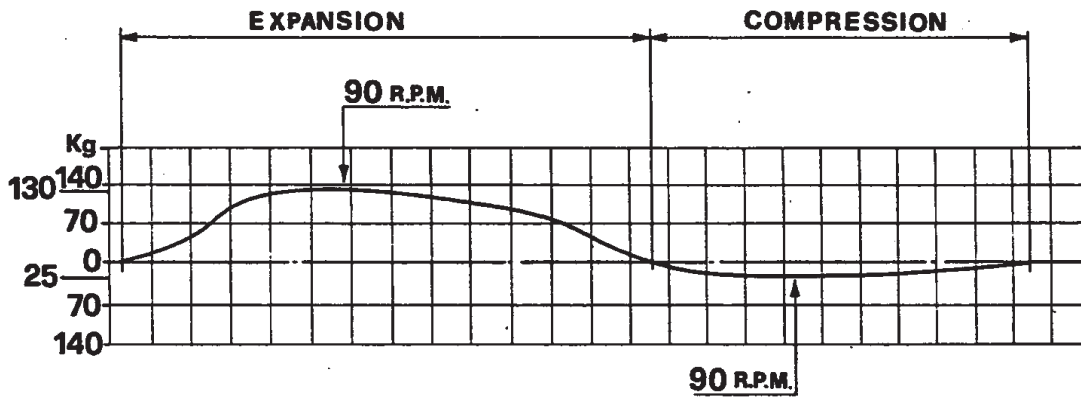

Fig. 7 - REAR SHOCK ABSORBERS. RATING DIAGRAM:
EXPANSION Kg. 130 - COMPRESSION Kg. 25.

SECTION **H**

BRAKES

WHEELS AND
TYRES

	Page
BRAKES	H 3
GENERAL INFORMATION	H 3
MAIN SPECIFICATIONS	H 3
TROUBLES AND REMEDIES	H 4
HYDRAULIC BRAKE SYSTEM	H 7
HANDBRAKE	H 8
BLEEDING THE HYDRAULIC SYSTEM	H 9
SERVICE INSTRUCTIONS	H 11
WHEELS AND TIRES	H 13
MAIN SPECIFICATIONS	H 13
TROUBLES AND REMEDIES	H 13
WHEEL BALANCING	H 15
REMOVING AND SERVICING	H 16

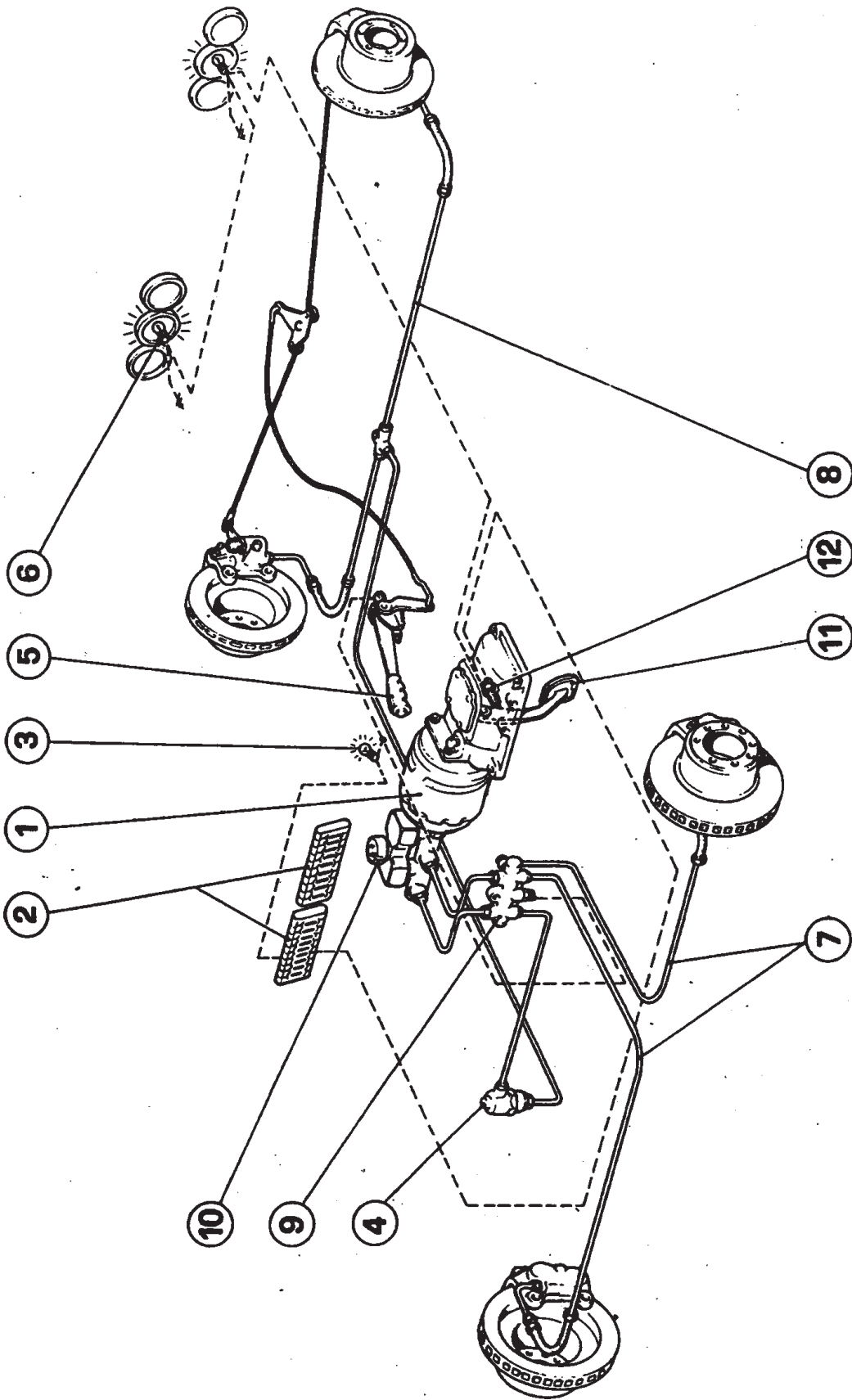

Fig. 1 - DIAGRAM of BRAKING SYSTEM.

1 - Vacuum brake booster; 2 - Fuses; 3 - Indicator for brake system failure, stop lights, and hand-brake engaged; 4 - Pressure limiting valve for rear brakes; 5 - Hand brake lever; 6 - Stop lights lamps; 7 - Front lights lamps; 8 - Rear circuit; 9 - Device for light signal of different oil pressure in the brake circuits; 10 - Brake fluid reservoir; 11 - Brake pedal; 12 - Stop lights switch.

B R A K E S

GENERAL INFORMATION	Page H 3
MAIN SPECIFICATIONS	" H 3
TROUBLES DIAGNOSIS AND REMEDIES	" H 4
HYDRAULIC BRAKE SYSTEM	" H 7
HAND BRAKE	" H 8
BLEEDING THE HYDRAULIC SYSTEM	" H 9
ADJUSTING BRAKE PEDAL FREE TRAVEL	" H 9
MAIN SERVICING INSTRUCTIONS	" H11
CHANGING BRAKE PADS	" H11

GENERAL INFORMATION

The hydraulically operated brakes consist of the following parts:

- Disc brake on the four wheels, self-ventilated type.
- Vacuum servo-brake acting on the front and rear wheels.
- Tandem master cylinder fixed to a vacuum servo-brake.
- Two hydraulic independent circuits.
- One feeding reservoir for the two circuits.
- Brake pressure limiting valve acting on the rear circuit.
- Device for light signal of different oil pressure in the brake circuits - warning light on the instrument panel.
- Mechanical emergency and parking brake acting on the rear wheels.

FRONT BRAKES MAIN SPECIFICATIONS

Type	ventilated disc - pedal operated
Brake discs:	
- diameter	mm. 271
- thickness (nominal (min. acceptable after trueing-up)	mm. 22 mm. 20
- maximum acceptable run-out with disc on hub (measured on comparator)	mm. 0,08
- maximum surface roughness (radial (perpendicular to radius)	μ 50 μ 32
Brake calipers	fixed type-2cylinders
- cylinder diameter	mm. 48
- brake pad surface	cm ² 164
Play adjustment between pads and discs	automatic
Fluid for hydraulic brakes	ATE type S
- quantity for the whole circuit (front and rear)	lt. 0,580

REAR BRAKES MAIN SPECIFICATIONS

Type	ventilated disc - pedal operated
Brake discs:	
- diameter	mm. 277
- thickness (nominal)	mm. 20
(min. acceptable after trueing-in)	mm. 18
- maximum acceptable run-out with disc on hub (measured on comparator)	mm. 0,08
- maximum surface roughness (radial)	μ 50
(perpendicular to radius)	μ 32
Brake calipers	fixed type 2 cylinders
- cylinder diameter	mm. 38
- brake pad surface	cm ² 104
Play adjustment between pads and discs	automatic
- brake regulator ratio	0,7
Fluid for Hydraulic brakes	ATE type S
Hand brake (acting on the rear wheels)	mechanically operated

TROUBLES DIAGNOSIS AND REMEDIES

BRAKE PEDAL JAMMED

POSSIBLE CAUSES	REMEDIES
1) Swollen master cylinder seals through use of unsuitable fluid or dilution of liquid with kerosene, gasoline or mineral oil.	1) Wash out system, change deteriorated rubber seals and fluid then bleed system.
2) Compensating holes of the master cylinder are blocked with dirt or not uncovered due to incorrect control play adjustment.	2) Clean and adjust the brake pedal free travel.
3) Brake pedal shaft seized in bushings.	3) Replace bushings.

BRAKE PEDAL TOO SOFT (Spongy)

POSSIBLE CAUSES	REMEDIES
1) System containing air due to improper bleeding.	1) Bleed system perfectly.
2) Flexible tube that expands under pressure because of poor quality.	2) Replace tubes and bleed the system.
3) Brake discs scored and new pads not perfectly adapted.	3) Grind scored surface.
4) Fluid leaking from pipe fittings or from seal rings of master cylinder.	4) Check and replace faulty parts.

BRAKE PEDAL TOO SOFT (Spongy) (continuation)

POSSIBLE CAUSES	REMEDIES
5) Plugged air vents on one or both feed reservoirs.	5) Clean and bleed the system.
6) Feed reservoirs without fluid or with emulsified fluid.	6) Change fluid and drain the system.

PEDAL TRAVEL TOO LONG, but BRAKING NOT SPONGY

POSSIBLE CAUSES	REMEDIES
1) Brake pads too far from the discs due to improper centering of same or due to hub excessive play.	1) Check disc runout; grind or replace the discs. Adjust bearing clearance.

BRAKES STILL APPLIED when PEDAL has been RELEASED

POSSIBLE CAUSES	REMEDIES
1) Brake pedal free travel insufficient.	1) Adjust play.
2) Lack of play between booster push rod.	2) Adjust play.
3) Cylinder compensating hole plugged or not uncovered.	3) Clean compensating hole, adjust pump push rod. Clean and bleed brake system.
4) Grommets expanded or sticking.	4) Wash out system, replace all rubber parts and fluid then bleed the system.
5) Flexible tubes too worn or partially plugged.	5) Change flexible tubes and bleed system.
6) Caliper pistons sticking and holding brakes on.	6) Overhaul caliper and change worn parts.
7) Power brake defective.	7) Check and replace if necessary.

BRAKES TOO HARD

POSSIBLE CAUSES	REMEDIES
1) Brake servo not operating properly due to rubber vacuum tube leaking or in side defect.	1) Check and change brake servo.
2) Improper brake pads type.	2) Change brake pads with prescribed type.
3) New brake pads not yet adapted to the disc surface or greasy.	3) 'Run-in' pads, carefully clean them with emery cloth or replace.

UNBALANCED BRAKES

POSSIBLE CAUSES	REMEDIES
1) Leakage of fluid from one caliper.	1) Dry, clean or change seals, overhaul caliper and bleed system.
2) One caliper piston seized.	2) Change complete piston and bleed system.
3) Hose choked.	3) Change or clean out hose and bleed system.
4) Improper brake pad quality or unequal on both calipers.	4) Change pads with correct quality.
5) Disc surfaces greasy.	5) Wash out brake discs and check where the fluid comes from.
6) Unequal tire pressure and wear.	6) Check the pressure.
7) Incorrect camber angle.	7) Adjust camber.
8) Incorrect suspension levers setting.	8) Check and adjust.
9) Excessive brake action on front wheels.	9) Check front and rear brake pads. If necessary, replace the pressure limiting valves for rear brakes.

IRREGULAR BRAKE PADS WEAR

POSSIBLE CAUSES	REMEDIES
1) Wrong caliper centering in relation to brake disc.	1) Check thrust washers and caliper bolts for loosening.
2) Slight opening of calipers under braking action.	2) Replace faulty calipers.
3) Rigid line plugged due to dents or clogging.	3) Change line or clean it; bleed the system.

WEAK BRAKING ACTION

POSSIBLE CAUSES	REMEDIES
1) Fluid leaking from caliper cylinders.	1) Check and change rubber seals
2) Rigid line plugged due to dents or clogging.	2) Change line or clean it; bleed the system.
3) Too worn brake pads.	3) Replace with new pads.

CREAKING and HISSING

POSSIBLE CAUSES	REMEDIES
1) Deposit of dust on brake pad surfaces.	1) Remove brake pads, clean the surfaces with emery cloth, lightly remove sharp corners, blow the calipers with compressed air then clean brake discs.
2) Low pressure on friction pads due to breakage or springs inefficiency.	2) Check and replace if necessary.

CREAKING and HISSING (continuation)

POSSIBLE CAUSES	REMEDIES
3) Brake pads smeared with oil or grease.	3) Clean pads throughout with wire brush and hot water. Replace if necessary.

FRONT BRAKES PULL TO ONE SIDE UNDER STRONG BRAKING ACTION

POSSIBLE CAUSES	REMEDIES
1) Incorrect suspension setting.	1) Check and adjust.
2) Unequal wear in front tires.	2) Invert the two wheels and change tires if necessary.
3) Improper brake pads quality.	3) Check and change if necessary.

DRAGGING BRAKES

POSSIBLE CAUSES	REMEDIES
1) Master cylinder piston seized.	1) Replace master cylinder.
2) Master cylinder overloaded by choking of compensating holes.	2) Change seal rings, clean the compensating holes, adjust pedal travel and bleed system.
3) Discs running out.	3) Check runout of discs.
4) Brake cylinders seized.	4) Overhaul caliper and replace cylinders.

BRAKE SYSTEM

The brake system consists of two hydraulic independent circuits: one for the front wheels and the other for the rear wheels.

Each caliper is equipped with two opposed horizontal cylinders and a screw protected with a rubber cover used for air bleeding.

In the rear circuit, a pressure limiting valve is fitted and operates according to the pressure applied to the brake pedal.

The limiting valve does not require any maintenance service and its setting must not be changed.

Between the two circuits, upstream of the rear brakes regulator, there is a device indicating different pressure in the two braking systems: should this inconvenient arise, the device (fig. 2) makes the relevant indicator on the instrument panel, light up.

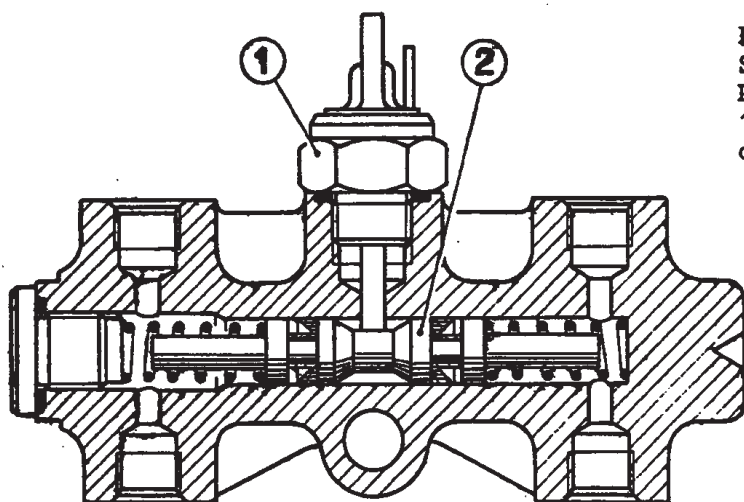

Fig. 2 - DEVICE for LIGHT SIGNAL of DIFFERENT OIL PRESSURE.

1 - Electric warning device; 2 - Piston.

Irregular operating can be due to:

- Fluid leaking from pipe fitting of one circuit.
- Fluid leaking from one cylinder seal.
- Reservoir with low fluid level.
- Master cylinder with one plugged compensating hole or with a bound piston.

This device does not require any maintenance operation therefore it must not be tampered.

EMERGENCY AND PARKING BRAKE

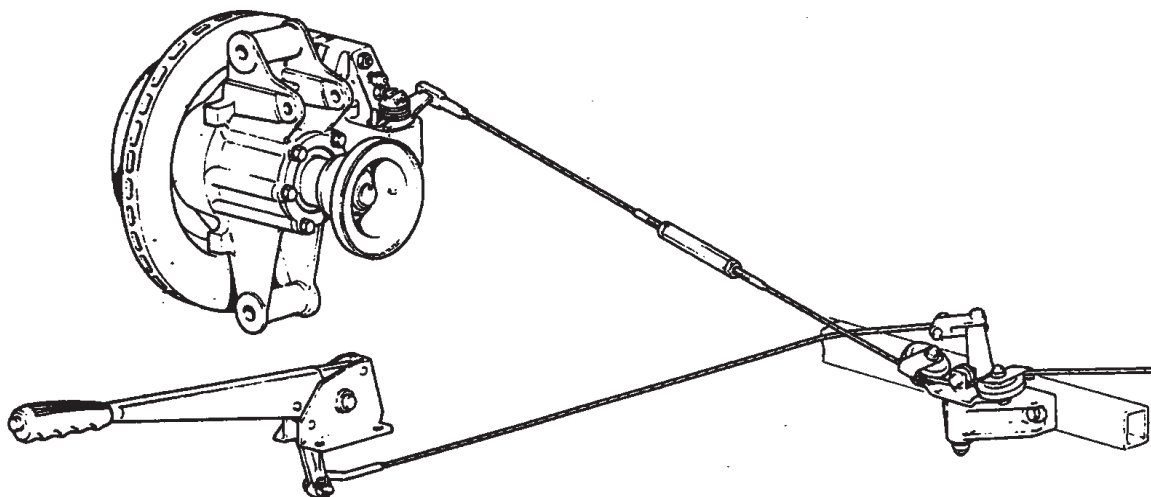

Fig. 3 - DIAGRAM of HAND BRAKE CONTROL.

The hand brake mechanically operates on the rear caliper cylinders; automatic clearance take-up. Operate on adjusting sleeve A (Fig. 4) only in case the control lever travel is very long.

A warning light located on the dashboard indicates that the hand brake is engaged.

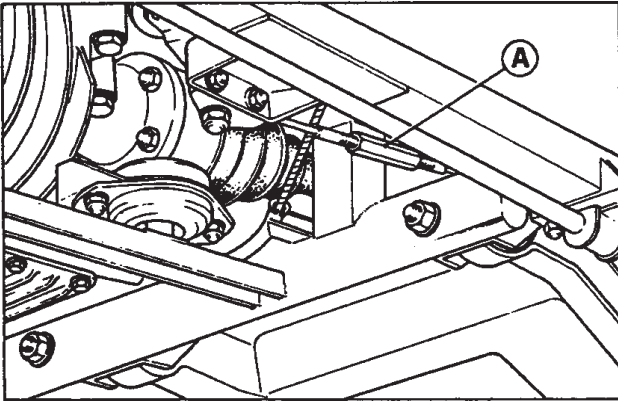

Fig. 4 - HAND BRAKE ADJUSTMENT.
A - Adjusting sleeve.

BLEEDING THE HYDRAULIC BRAKE SYSTEM

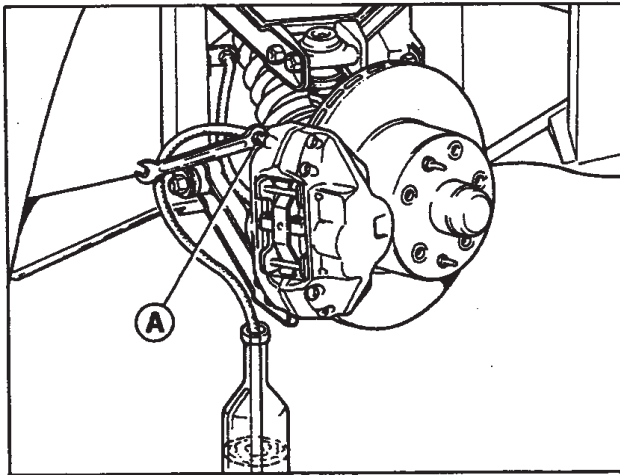

Fig. 5 - AIR BLEEDING FROM BRAKE CYLINDERS.
A - Air bleeding screws.

Fill the fluid reservoir and make sure that during the bleeding operation the fluid is never under 1/4 of the maximum level. Top-up the level with new fluid contained in sealed cans. Never use again the fluid which has come out of the bleed tubes. Bleed the front wheel brakes. Remove the rubber caps from the two caliper tubes then apply to one screw one plastic tube having one free end into a glass container. Press the brake pedal completely for some times until the fluid comes out of the tube. Then tighten the screw with the pedal fully pressed.

Effect the same operation on the other caliper then on those of the rear circuit.

Once the bleeding operation has been carried out, the brake pedal should be no longer spongy and the braking action should be progressive just after the brake pedal short free travel has been overcome.

Every 10000 km, or every 6 months at most, change the brake fluid. This operation will eliminate any possible trace of moisture in the brake system.

ADJUSTMENT OF BRAKE PEDAL FREE TRAVEL

For a correct brake operation, it is necessary that the brake pedal performs a free travel of 8 + 10 mm. before operating the master cylinder. For this purpose, the push rod inside the brake booster controlling the master cylinder, is supplied by the manufacturer with adjusted clearance. This clearance must be never changed : it is

therefore recommended not to disjoin the master cylinder from the brake booster. If necessary, replace the complete unit.

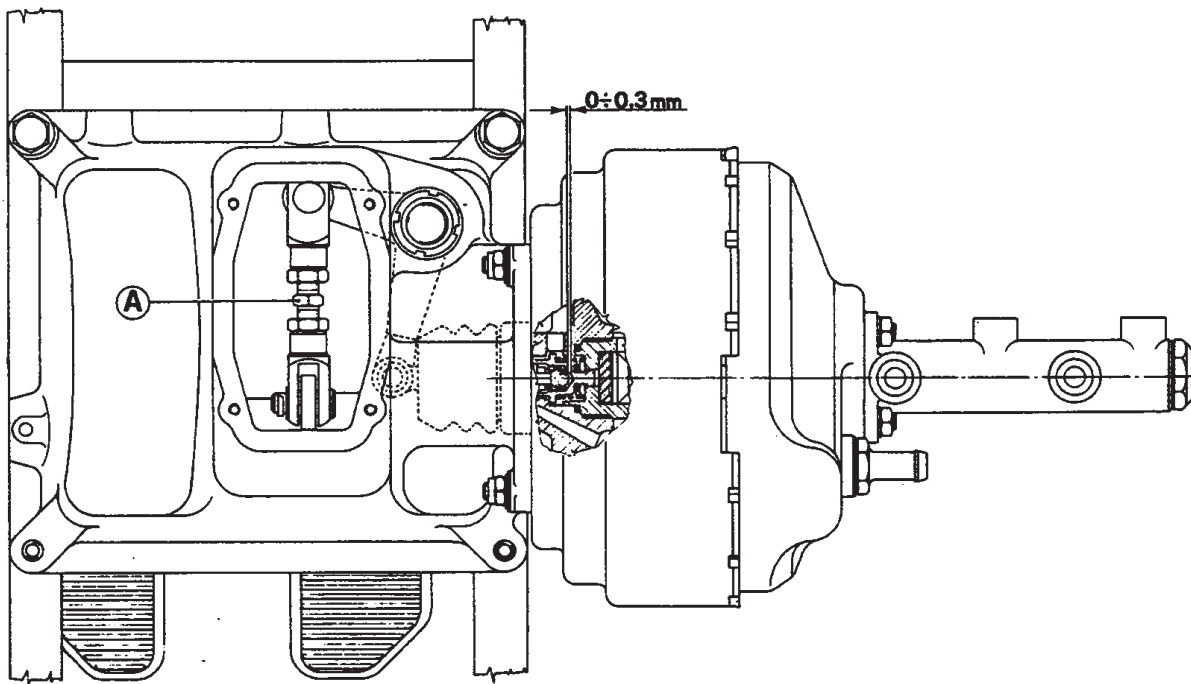

Fig. 6 - CLEARANCE of BRAKE BOOSTER PUSH ROD.

A - Adjusting tie rod.

The tie rod A which connects the brake pedal to the booster lever, should be properly adjusted so that the clearance of the booster push rod is within $0 \pm 0,3$ mm.

After clearance adjustment, the brake pedal free travel should be mm. 8 ± 10 .

Clearance adjustment should be effected when the pedal is in rest position which is controlled by the stop light switch. Should this position be changed establish again the free travel operating the adjusting tie rod as already described.

The brake pedal free travel is mm. 107 measured near the centerline of pedal plate.

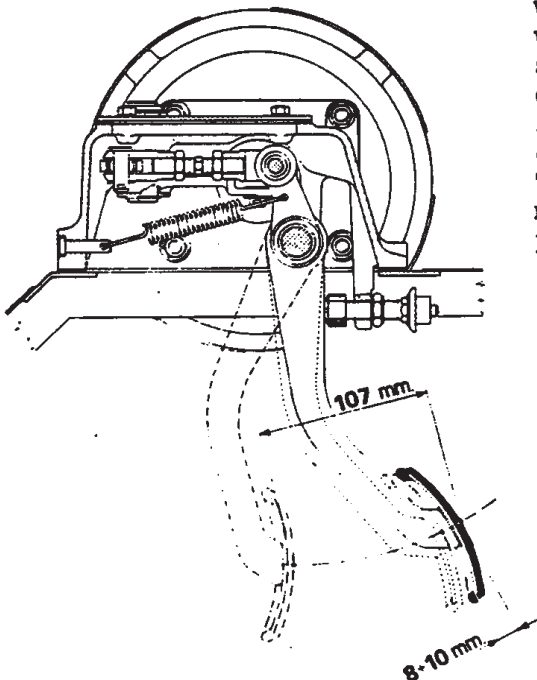

Fig. 7 - BRAKE PEDAL TRAVEL.

MAIN MAINTENANCE SERVICES

Every 5000 km. check and, if necessary, reset the fluid level in the reservoirs. Check also the braking surfaces for wear.

If the pedal travel is excessively long or the brake action is irregular, effect a careful inspection of the whole system to check for possible leaks. Check brake pad condition: if pad thickness is not near to wear limit, bleed the system with care. Pad thickness can be checked from outside after removing the wheels.

It is advisable to replace the front and rear brake pads every 10000 km.; check brake discs faces and, without withdrawing the pistons, make sure of the piston correct sliding inside cylinders.

Every 30000 km. it is recommended to effect a careful inspection of the whole system (pipes, calipers and so on).

Besides, it is absolutely necessary to replace the rubber sealings when withdrawing the pistons from cylinders.

The grinding of disc surfaces, when requested, should be effected by a skilled workshop: infact, the surface roughness and the axial run-out of the discs fitted to the hub, must be absolutely as prescribed (see page H 3-4).

When grinding the discs, the original thickness should not be reduced over 2 mm.

CHANGING BRAKE PADS

WARNING : When it becomes necessary to change or inspect the pads, wash first the external part of the calipers using hot water and mild detergent then dry with compressed air.

Never use gasoline, diesel oil, tricoethylene, etc., as these may damage the hydraulic cylinders sealings.

If the pads to be replaced are not equal in thickness, check that the calipers are true in relation to disc faces. If not, change the number of the relevant spacers located between caliper and support.

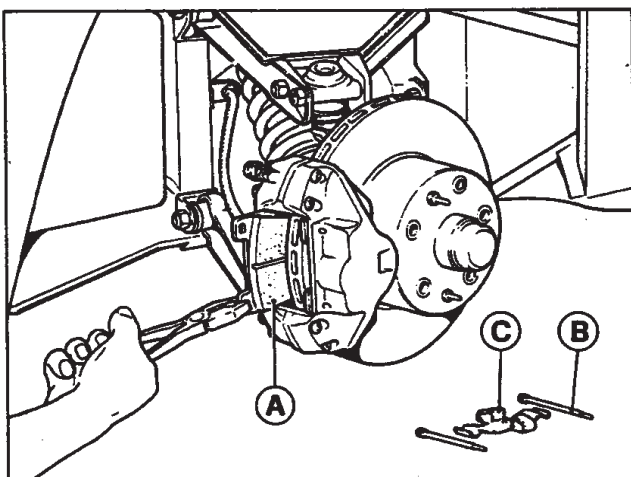

Fig. 8 - CHANGING BRAKE PADS.
A - Pads; B - Pin; C - Flat spring.

See our technical information relevant to the use of correct type of pads.

Do not use brake pads with a thickness lower than 3 mm. (thickness of the friction pad only); the replacement must be carried out following the above instructions.

To remove the brake pads, withdraw the two locking pins and the retainer spring toward the internal side of the car.

Using pliers, remove the brake pads then, before fitting the new pads drive the pistons into the cylinders: during this operation avoid to damage the cylinder sealings.

Insert the new pads then refit the pins and the retainer spring.

When this operation has been completed and before starting the car, operate the brake pedal frequently in order to bring the pistons to the operating standard position.

Effect a long 'run-in' of the pads avoiding strong braking actions.

WHEELS AND TYRES

MAIN SPECIFICATIONS Page H 13
 TROUBLES DIAGNOSIS AND REMEDIES " H 13
 WHEEL BALANCING " H 15
 ASSEMBLING AND SERVICING INSTRUCTIONS " H 15
 ASSEMBLING AND INFLATING INSTRUCTIONS " H 15
 REPAIR INFORMATION " H 16

MAIN SPECIFICATIONS

Light alloy wheels	type	14" x 6 1/2			
Radial tyres	type	Michelin 205/70 VR14 xwx Tubeless Goodyear 205/70 VR14 GranPrix 800			
Spare tyre	type	Michelin 105 R 18 x Tubeless			
PRESSURE WITH COLD TYRES		MICHELIN		GOODYEAR	
		rear	front	rear	front
Up to 150 km/h	kg/cm2	2,0	1,8	2,0	1,9
Up to 200 km/h	kg/cm2	2,4	2,1	2,3	2,0
Over 200 km/h	kg/cm2	2,6	2,2	2,9	2,5
Spare tyre	kg/cm2	5 - max. speed 150 km/h			

TRoubles DIAGNOSIS AND REMEDIES

EXCESSIVE TYRE WEAR

POSSIBLE CAUSES	REMEDIES
1) Excessive speed over very rough ground.	1) Drive at moderate speed according to road surface conditions.
2) Sudden speed changes due to rapid acceleration or harsh braking.	2) Avoid unnecessary acceleration or braking.
3) Excessive speed with tyres under correct pressure.	3) Check pressure with tyres cold and adjust.
4) Excessive tyre pressures.	4) Reduce pressure to correct values.

IRREGULAR TYRE WEAR

POSSIBLE CAUSES	REMEDIES
1) Driving too fast on bends.	1) Drive more slowly on bends.
2) Skidding on bends due to faulty suspension.	2) Overhaul suspension.
3) Wheels out of balance.	3) Balance wheels.
4) Incorrectly balanced braking.	4) Overhaul braking system.

EXCESSIVE TYRE WEAR (continuation)

POSSIBLE CAUSES	REMEDIES
5) Excessive clearance in wheel bearings.	5) Adjust clearance.
6) Ineffective shock absorbers.	6) Change or overhaul shock absorbers.
7) Different tyre pressures on one axle.	7) Check and adjust pressures to correct values.
8) Incorrect front and rear wheel camber angle: wear occurring on one side of tread only.	8) Check camber angle; if it is correct, wear is due to over-fast cornering.
9) Insufficient toe-in: wear chiefly on inside tread.	9) Check and adjust.
10) Excessive toe-in: wear chiefly on outside tread.	10) Check and adjust.
11) Tyre pressure too low: more wear on sides of tread than on center.	11) Adjust tyre pressure to correct values.
12) Excessive tyre pressure: wear is greatest in center of tread.	12) Reduce pressure to correct values.
13) Steering out of adjustment, excessive toe-in on one wheel and too little on the other; wear is more evident on inside of tread on one wheel and on outside of the other.	13) Adjust wheel setting and make sure of steering parts efficiency.

CAR PULLS to ONE SIDE

POSSIBLE CAUSES	REMEDIES
1) Front wheels out of balance.	1) Balance wheels.
2) Different pressure between the front wheels and between the rear wheels.	2) Check and adjust pressures to correct values.
3) Excessive difference in wear between pairs of tyres.	3) Change badly worn tyres and fit the new ones to the front.
4) Incorrect alignment between front and rear wheel axis.	4) Check and correctly line up.
5) One front wheel fitted to the rear.	5) Reverse the two tyres.
6) Different camber angle between the two front wheels or the rear ones.	6) Check and adjust camber angle on front and rear wheels.

WARNING

If the vehicle shows a tendency to pull to one side or to the other when releasing the accelerator pedal at high speed, a careful inspection of the tyre conditions becomes necessary.

The rear tyres should be changed if their treads are worn down to 2 mm. even if an excessive wear, mainly on the edges, is not evident. If the defect does not disappear, change also the front tyres even if an irregular wear is not noticeable and the tread depth is still over 2 mm.

WHEEL BALANCING

It is most important that wheels and tyres are correctly balanced to avoid any shake of the front wheels which could badly affect the steering and cause abnormal tyre wear.

The causes of bad balance are:

- wheel running-out radially, due to eccentricity of tyre and rim;
- weight unequally distributed around the axis of rotation.

The wheels should be dynamically and statically balanced using the balancing apparatus and suitable counterweights.

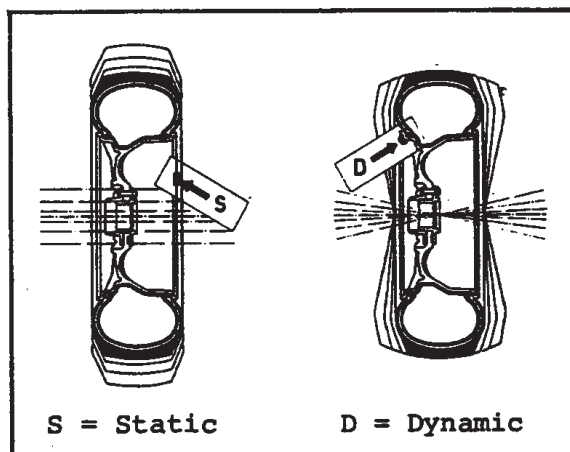

Fig. 9 - STATIC AND DYNAMIC BALANCING.

If the wheel balancing requires a counterweight which is over 80 gr. move the tyre on the wheel for half turn. When the weight exceeds 60 gr., it would be better to apply two of them of 30 grammes each.

WARNING

It is strongly recommended, after applying the weights, to make sure that when steering the wheels in the two directions making them perform maximum bump stroke, they never touch the brake flexible lines and are perfectly fixed to the rims.

ASSEMBLING AND SERVICING INSTRUCTIONS

The following instructions concern tyre assembling, inflating and service operations.

ASSEMBLING AND INFLATING

Cleaning of tyre and rim seal surfaces is very important to correctly carry out the fitting operation. Do not use wire brush since it can remove the protective coating on light alloy wheels. Therefore, use rags to clean the seal surfaces.

Grease with 'MICHELIN RIC 1291 lubricant' the bead sides of tyre and the rim balconies to make easier the assembling.

Before fitting the tubeless tyre, make sure that the valve is correctly tightened on the rim. Should any replacement be necessary, avoid to rotate the valve on its seat during assembling operation since this could damage the sealing ring under head: a hexagon is made on the head to hold the valve by a wrench.

Fit the tubeless tyre to the rim helping with standard tool equipment.

Inflate the tyre at a maximum pressure of 3 + 3,5 kg/cm²: this will help the settling of the tyre beads against balconies. Should any difficulty arise when inflating the tyre, it is advisable to remove the inner part of the valve to allow a larger flow of air.

REPAIR PROCEDURE

Do not remove the tyre but inflate it at a pressure of 2 kg/cm² then look for air leaking by smearing the tyre with soapy water. Mark any possible punctures or put a pin through them so to have a reference inside the carcass, then remove the tyre from the rim. Turn over the carcass putting outward the punctured surface then rub with a wire brush: do not blow on the rubbed surface since this will remove the powder. Spread a light layer of 'MICHELIN RERAS sealing' then let dry. Spread a second layer of sealing, let dry again then apply one 'MICHELIN 35 x 35' rubber pad; roll the pad to make sure of its perfect adhesion then, after reassembling, check for perfect impermeableness.

The maximum cleaning is essential to ensure a perfect repair operation. It is also recommended to avoid the use of any solutions or pads of other brands.

The MICHELIN vulcanizing solution is supplied in tubes called 'RERAS' while the MICHELIN rubber pads are individualized by their size 35 x 35.

Absolutely avoid to repair the tyre with different operation like injection of solution by spraying bottles or insertion from outward of threaded rubber pins which are used to repair industrial vehicle tyres.

For safety's sake, we also advise against repairing tyres which are seriously punctured since the fibre tearing could have greatly reduced the tyre resistance.

SECTION

INSTRUMENTS
AND
CONTROLS
HEATING
AND
VENTILATION
AIR
CONDITIONING

	Page
GENERAL INFORMATION	I 3
IGNITION SWITCH AND ANTI-THEFT DEVICE	I 4
MAINSWITCH	I 4
WINDSCREEN WIPER	I 5
HORNS	I 5
GENERAL INFORMATION	I 7
OPERATING INFORMATION	I 7
TROUBLES AND REMEDIES	I 8
GENERAL INFORMATION	I 9
MAIN SPECIFICATIONS	I 9
TESTING THE SYSTEM FOR EFFICIENCY	I 10
DIAGNOSIS OF THE SYSTEM	I 10
OPERATION OF CONTROLS	I 13
OPERATING INFORMATION	I 14
PRELIMINARY OPERATIONS FOR SYSTEM RECHARGING	I 16
COMPLETE CHARGE OF SYSTEM	I 17
ADJUSTMENT OF COMPRESSOR CONTROL BELT TENSION	I 18

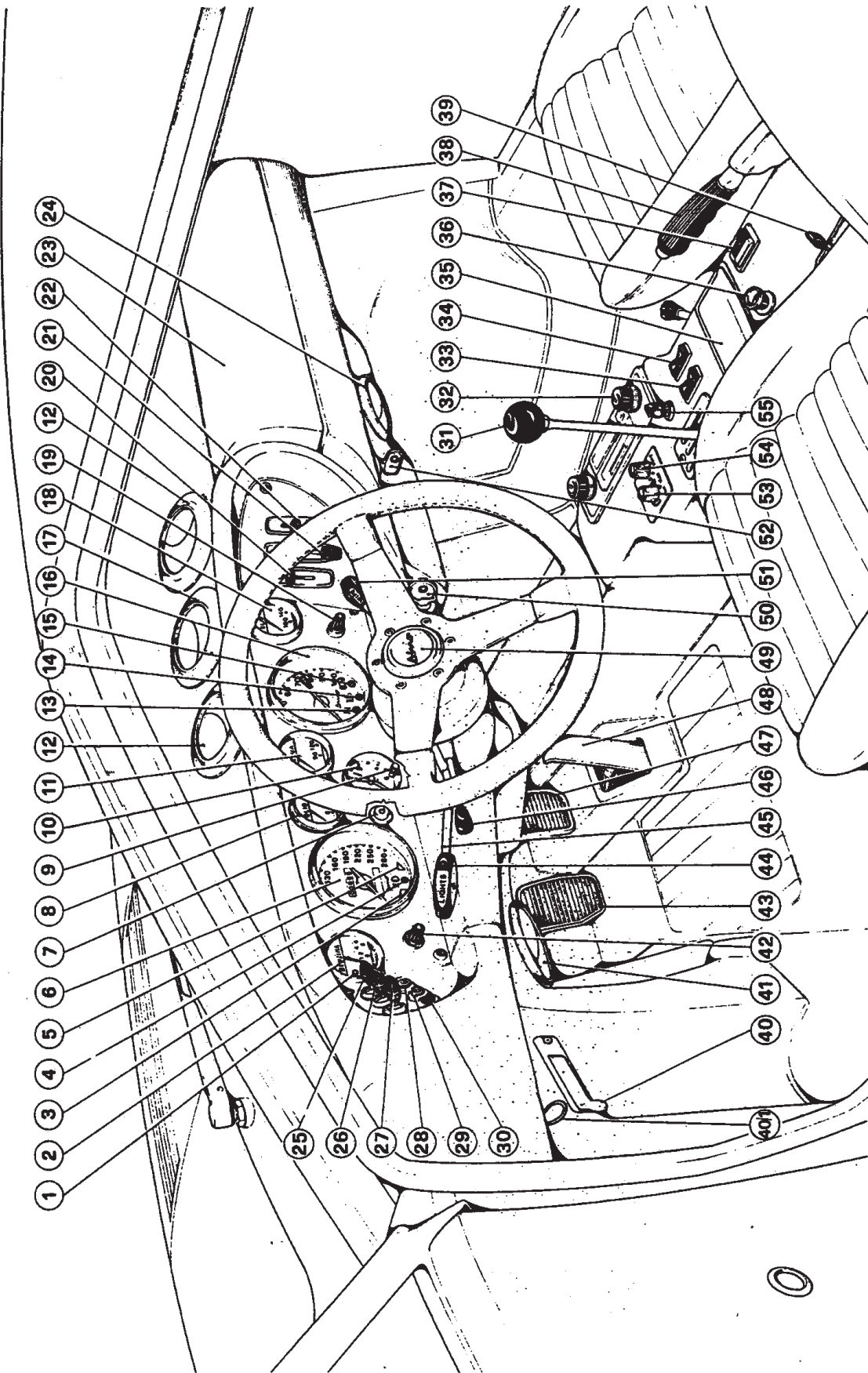

Fig. 1 - INSTRUMENTS AND CONTROLS.

INSTRUMENTS AND CONTROLS

GENERAL INFORMATION	Page I 3
IGNITION SWITCH AND ANTI-THEFT DEVICE	" I 4
AUXILIARIES CONNECTED TO THE IGNITION SWITCH	" I 4
MAINSWITCH	" I 4
WINDSCREEN WIPER	" I 5
HORNS	" I 5

GENERAL INFORMATION

The control and indication equipment consists of:

- | | |
|--|---|
| 1 - Fuel reserve warning light (red). | 28 - Fog light indicator (FOG) (yellow). |
| 2 - Fuel level gauge. | 29 - Vehicle HAZARD warning light.(red). |
| 3 - Left turn signal arrow indicator (green). | 30 - Defroster warning light (FAN) (orange). |
| 4 - Parking and tail lights indicator (green). | 31 - Gearbox lever . |
| 5 - Right turn signal arrow indicator (green). | 32 - Radio. |
| 6 - Electronic speedometer. | 33 - L.H. window control switch. |
| 7 - Generator warning light (red). | 34 - R.H. window control switch. |
| 8 - Oil pressure gauge. | 35 - Ash-tray. |
| 9 - Clock setting control knob: push and rotate clockwise. | 36 - Cigarette lighter. |
| 10 - Electric clock: operating independently from the ignition key position. | 37 - Thermic window demister switch with warning light. |
| 11 - Engine water temperature gauge. | 38 - Hand-brake lever. |
| 12 - Adjustable air outlets for warm or fresh air. | 39 - Choke control. |
| 13 - Choke warning light (yellow). | 40 - Front lid opening lever. |
| 14 - Main beam warning light (blue). | 40/1 - Ring for front lid emergency opening. |
| 15 - Warning light for brake system failure - stop lights - hand-brake on (red). | 41 - Adjustable air outlets for warm or fresh air to driver's feet. |
| 16 - Revolution counter. | 42 - Speedometer trip control. |
| 17 - Adjustable air outlet diffuser | 43 - Clutch pedal. |
| 18 - Oil temperature gauge. | 44 - Retractable headlights and lights switch. |
| 19 - Instrument cluster light rheostat. | 45 - Main beam/dipped beam control lever. |
| 20 - L.H. heater air distribution control. | 46 - Direction indicators control lever. |
| 21 - Heater temperature control. | 47 - Brake pedal. |
| 22 - R.H. heater air distribution control. | 48 - Accelerator pedal. |
| 23 - Glove-box compartment. | 49 - Horn button. |
| 24 - Adjustable air outlet for warm or fresh air to passenger's feet. | 50 - Ignition switch, auxiliaries, starter and anti-theft device. |
| 25 - Switch for anti-fog lights (FOG). | 51 - Windscreen wiper and washer control lever. |
| 26 - Vehicle HAZARD warning light switch. | 52 - Glove-box lid lock with key. |
| 27 - Defroster switch (FAN). | 53 - Temperature control for air conditioning system. |
| | 54 - Air volume control for air conditioning system. |
| | 55 - Electric aerial switch. |

IGNITION SWITCH WITH ANTI-THEFT DEVICE

This switch (fig. 2) has a key which can be placed in four positions:

- 0 : Locked (locked steering and removable key). The lights may be switched on by turning the knob 44 on the control lever 45 and moving the lever in one of the three positions. (Fig. 1).
- I : Steering is free, key is not removable.
- II: Running (ignition on, electric fuel pump on, auxiliaries arranged to operate).
- III: Starting.

WARNING

In order to unlock the steering it is sometimes necessary, whilst attempting to rotate the key, to try and rotate the steering wheel back and forth.

Do not remove the key if the car is not stationary.

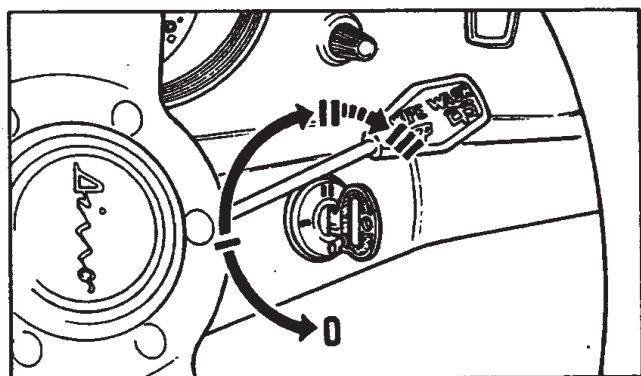

Fig. 2 - IGNITION SWITCH WITH ANTI-THEFT DEVICE.

AUXILIARIES CONNECTED TO THE IGNITION SWITCH

Circuits operated by the ignition key (position II):

Ignition - starting - generator - windscreen wiper and electric washer pump - direction lights - stop lights - radiators cooling fan motors - fuel electric pump - instruments (quartz clock excluded) - thermic rear window and relevant warning light - heater fan motors - air conditioning unit - window regulator motors.

Starting (position III):

Auxiliaries independent of the ignition key.

- Parking lights - main and dipped beams - instruments lighting - engine bonnet light - vehicular hazard lights - horns - cigarette lighter - clock - glove-box light - interior lights - radio.

MAINSWITCH

This unit consists of the following devices:

- selector switch controlling direction indicators, with automatic return when steering wheel is brought back to straight ahead position;
- selector switch controlling outside lights and flashers on low beams.

The two devices form a single unit which is mounted under the steering wheel. If there is any defect in this, change the complete unit.

TESTING THE SYSTEM FOR EFFICIENCY

The conditioning system should operate for approx. 15' in order to settle all relevant components.

Make sure that the system is completely charged: for this use test gauges and the drier indicator.

Maximum pressure will be 13 kg/cm² or more, according to ambient temperature.

The drier indicator should not have any bubbles inside.

The low pressure of the system should be from 1 to 2 kg/cm² according to ambient temperature.

See here below the maximum values of high pressures in relation to ambient temperature.

Ambient temperature	High pressure
27° C	10 + 12 kg/cm ²
32° C	12 + 14 kg/cm ²
35° C	13 + 14,5 kg/cm ²
38° C	15 + 16,5 kg/cm ²
40° C	16,5+18 kg/cm ²

TEMPERATURES CHECKED ON HIGH AND LOW PRESSURE PARTS

The high pressure lines should be uniformly warm: difference in temperature will indicate partial plugging in fluid or gas pipes.

The low pressure lines should be uniformly cold but they should not present excessive transpiration on suction pipes or on compressor auxiliary valves.

Excessive transpiration or freezing of the low pressure valve, usually indicates that expansion valve sends excessive volume of coolant to the evaporator.

DIAGNOSIS OF THE SYSTEM

1st Case

Insufficient cooling due to shortage of coolant: fluid leaking.

- 1 - Too low pressure on low pressure gauge.
- 2 - Too low pressure on high pressure gauge.
- 3 - No bubbles in the filter indicator: there is no fluid but gas only.

Deductions:

Shortage of coolant in the system. Look for possible leakages and re fill the system.

2nd Case

Insufficient cooling due to shortage of coolant: small failure or leakings.

- 1 - Low pressure on low pressure gauge.
- 2 - Low pressure on high pressure gauge.
- 3 - Bubbles and haziness appearing in the filter indicator.

Deductions:

Shortage of coolant in the system due to leakings.

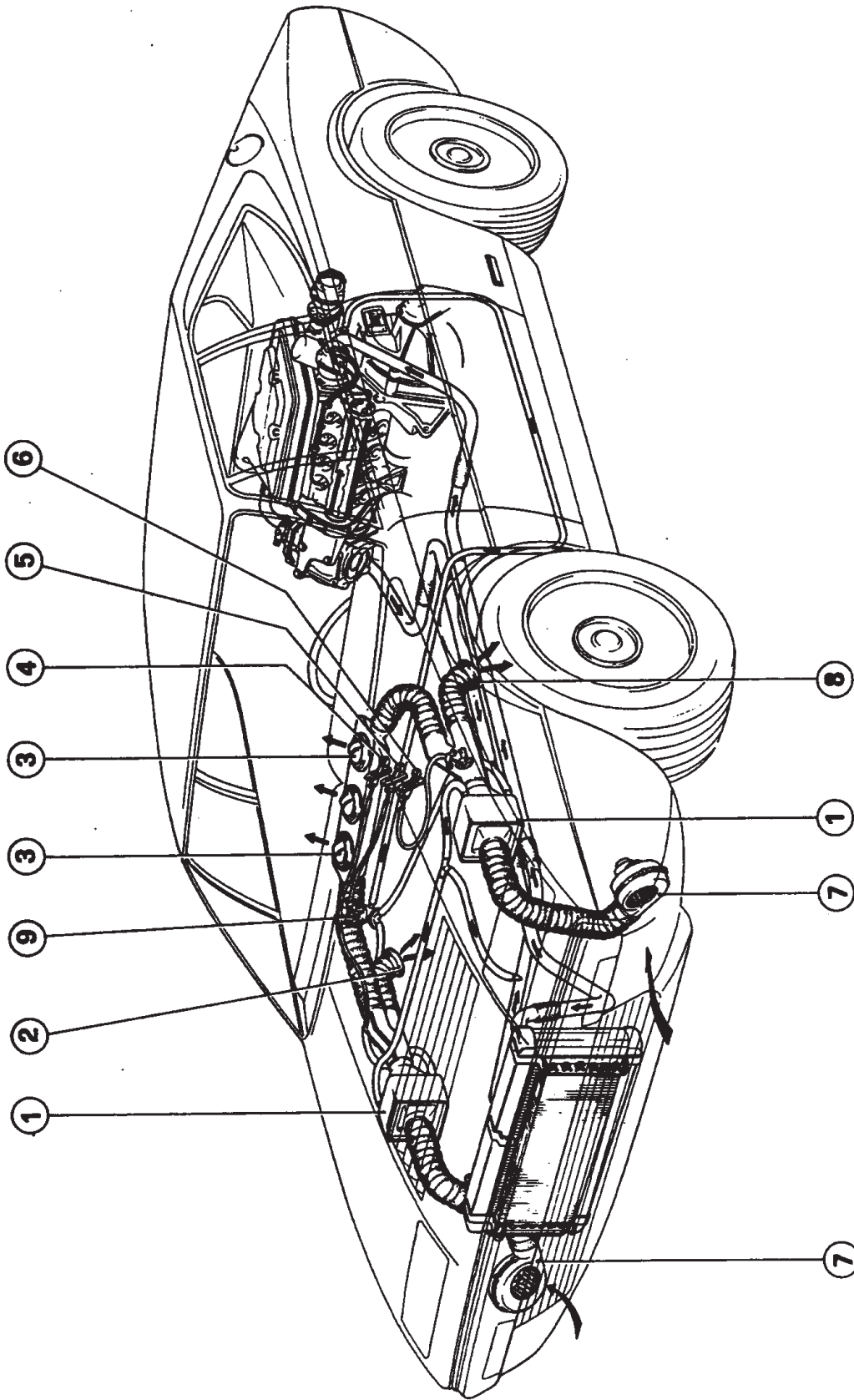

Fig. 3 - DIAGRAM OF HEATING and VENTILATION SYSTEM.

1 - Heaters; 2 - Adjustable air outlet for warm or fresh air to passenger's feet;
 3 - Adjustable air outlets for warm or fresh air; 4 - Right hand heater air distribu-
 tion control; 5 - Heater temperature control (hot water); 6 - Left hand heater air
 distribution control; 7 - Front air intake fans; 8 - Adjustable air outlet for warm
 or fresh air to driver's feet; 9 - Tap.

HEATING AND VENTILATION

GENERAL INFORMATION	Page I 7
OPERATING INFORMATION	" I 7
WINTER HEATING	" I 7
SUMMER VENTILATION	" I 7
INTERMEDIATE TEMPERATURES	" I 7
TROUBLES DIAGNOSIS AND REMEDIES	" I 8

GENERAL INFORMATION

The vehicle is not fitted with vent wings so air exchange is obtained with close passenger compartment thus improving the vehicle quietness. Air reaches the passenger compartment by two intakes located to the front grill sides and it gets warm when passing through the two water radiators. Afterwards, air is delivered to the outlets located on the dashboard and to passenger and driver's feet.

WINTER HEATING (fig. 3)

To inject warm air into the car or onto the windscreen for demisting and prevent icing, these are the necessary operations:

- 1 - Lower completely the hot water tap moving the lever 5 near the red spot.
- 2 - Move levers 4 and 6 to the mid position: in this way hot air will be delivered to the adjusting outlets.
- 3 - Lower completely levers 4 and 6 to send warm air to windscreen only.
- 4 - In order to increase the flow of warm air when running at low speed, connect the electric fans 7 by lowering switch 27 (fig. 1).

In case the vehicle must be left stationary for some time in winter weather without antifreeze mixture in the cooling system, drain completely the water from radiator and engine; also the remaining water inside the heating radiators must be discharged by raising the rear side of the car.

SUMMER VENTILATION

Air from outside can be delivered into the car in the following way:

- 1 - Close the hot water tap by lowering lever 5 to the blue spot.
- 2 - Repeat the procedures indicated at points 2 and 3 of the above heading.
- 3 - When the car speed is slow and it is required to increase the flow of air, switch on the electric fans 7 by lowering switch 27 (fig. 1).

INTERMEDIATE TEMPERATURES

To demist the windscreen during intermediate weather, act as per points 1) and 3) of 'Winter Heating' heading.

TROUBLES DIAGNOSIS AND REMEDIES

INSUFFICIENT HEATING

POSSIBLE CAUSES	REMEDIES
1) Insufficient hot water to heaters: a) Tap not completely open. b) Faulty tap. c) Hot water pipes partially clogged. 2) Damaged thermostatic valve. 3) Control valves damaged or ineffective. 4) Front electric fans damaged or with fuses burnt-out.	a) Check tap and control cable. b) Replace tap. c) Check and remove the inconvenient. 2) Replace valve. 3) Check valves and controls. 4) Replace fuses and, if necessary, the damaged electric fan.

A I R C O N D I T I O N I N G

GENERAL INFORMATION	Page I 9
MAIN SPECIFICATIONS	" I 9
TESTING THE SYSTEM FOR EFFICIENCY	" I 10
DIAGNOSIS OF THE SYSTEM	" I 10
OPERATION OF CONTROLS	" I 13
MAINTENANCE INSTRUCTIONS	" I 14
OPERATING INFORMATION	" I 14
IMPORTANT INSTRUCTIONS	" I 14
PRELIMINARY OPERATIONS FOR SYSTEM RECHARGING.	" I 16
COMPRESSOR AUXILIARY VALVES	" I 16
DRAINING THE SYSTEM BY VACUUM PUMP.	" I 16
RECHARGING THE SYSTEM THROUGH GAS STATION	" I 17
COMPLETE CHARGE OF THE SYSTEM	" I 17
LOOKING FOR POSSIBLE LEAKAGES	" I 17
ADJUSTMENT OF COMPRESSOR CONTROL BELT TENSION	" I 18

GENERAL INFORMATION

The system consists of a compressor which is driven by the engine through an electro-magnetic clutch; this clutch is operated by the battery current through a switch located on the tunnel.

The compressor makes the fluid (FREON 12) circulate through the condenser, the drier cleaner, the expansion valve and the evaporator then it returns back to the compressor.

Temperature and air flow inside the passenger compartment can be adjusted by a thermostat and a rheostat which are fitted on the central tunnel.

Warm and wet air is sucked by the evaporator through proper slots located under the dashboard. Through the evaporator, the air cools and loses in moisture which, after condensating, is discharged outside.

Then, cool air is delivered into the passenger compartment through a diffuser located on the dashboard.

For an efficient system operating, make sure that there is no moisture in it and the warm air leakings are reduced to minimum. For this purpose, carefully check the doors sealing.

MAIN SPECIFICATIONS

System type	Borletti
Compressor	Aspera - Frigo HG 700 AP
Operating pressure	See table on page I 10
Fluid type	FREON 12 Anidro
System capacity	kg. 1
Replace fluid (excluding leakages)	Once a year
Oil for compressor	Agip TER 54 or SUNISO G 4
Oil level in compressor	mm. 38 + 40
Inspection (excluding leakages)	Once a year

TESTING THE SYSTEM FOR EFFICIENCY

The conditioning system should operate for approx. 15' in order to settle all relevant components.

Make sure that the system is completely charged: for this use test gauges and the drier indicator.

Maximum pressure will be 13 kg/cm² or more, according to ambient temperature.

The drier indicator should not have any bubbles inside.

The low pressure of the system should be from 1 to 2 kg/cm² according to ambient temperature.

See here below the maximum values of high pressures in relation to ambient temperature.

Ambient temperature	High pressure
27° C	10 + 12 kg/cm ²
32° C	12 + 14 kg/cm ²
35° C	13 + 14,5 kg/cm ²
38° C	15 + 16,5 kg/cm ²
40° C	16,5+18 kg/cm ²

TEMPERATURES CHECKED ON HIGH AND LOW PRESSURE PARTS

The high pressure lines should be uniformly warm: difference in temperature will indicate partial plugging in fluid or gas pipes.

The low pressure lines should be uniformly cold but they should not present excessive transpiration on suction pipes or on compressor auxiliary valves.

Excessive transpiration or freezing of the low pressure valve, usually indicates that expansion valve sends excessive volume of coolant to the evaporator.

DIAGNOSIS OF THE SYSTEM

1st Case

Insufficient cooling due to shortage of coolant: fluid leaking.

- 1 - Too low pressure on low pressure gauge.
- 2 - Too low pressure on high pressure gauge.
- 3 - No bubbles in the filter indicator: there is no fluid but gas only.

Deductions:

Shortage of coolant in the system. Look for possible leakages and re fill the system.

2nd Case

Insufficient cooling due to shortage of coolant: small failure or leakings.

- 1 - Low pressure on low pressure gauge.
- 2 - Low pressure on high pressure gauge.
- 3 - Bubbles and haziness appearing in the filter indicator.

Deductions:

Shortage of coolant in the system due to leakings.

(Warning : It is normal that the conditioning system loses 200 + 500 grams of fluid in one year). Look for the leaking and refill the system.

3rd Case

Insufficient cooling due to non-condensable fluid (air) and moisture in the system.

- 1 - Constant pressure read on the low pressure gauge (pressure should decrease until the clutch disconnects the compressor - the pressure gauge should indicate a slow oscillation).
- 2 - Pressure a little high read on high pressure gauge.
- 3 - Filter indicator is clean from bubbles or it shows only some rare bubbles.
- 4 - The suction pipe is warm to the feel.

Deductions:

Non-condensable fluid (air) in the system. Air and moisture in the freon. Look for the leaking, drain the system and replace the drier cleaner. Refill the system.

4th Case

Insufficient cooling due to leakings inside the compressor or from the compressor sealing.

- 1 - Too high pressure read on the low pressure gauge.
- 2 - Too low pressure read on the high pressure gauge.
- 3 - The system is completely charged (absence of bubbles in the filter).

Conclusions:

Check and set the compressor.

5th Case

Warm air from the evaporator - faulty operating of condenser.

- 1 - Pressure excessively high read on low pressure gauge.
- 2 - Pressure excessively high read on high pressure gauge.
- 3 - Bubbles could appear on the indicator.

Conclusions:

Faulty operating of condenser: too high pressure in the high pressure lines is the cause of poor cooling. Check fans and condenser, the system could be overcharged with coolant; the condenser could be plugged with oil.

6th Case

The conditioning system operates fairly well in the morning and in the evening but it does not cool when outside temperature is very high.

- 1 - Pressure is between 1 + 2 kg/cm² read on the low pressure gauge. Sometimes the pressure descends to zero.
- 2 - Pressure is approx. 15 kg/cm² read on high pressure gauge. When low pressure descends to zero, at the same time descends also the high pressure.
- 3 - At the beginning air is cold, then it warms up when the low pressure approaches zero.

Conclusions:

Drier filter is saturated with moisture and exhales moisture when at high temperature sending it to the expansion valve where it freezes and stops the coolant flow. Drain the system, replace the drier

filter and recharge the unit.

7th Case

The evaporator delivers warm air because of non-condensable fluids which have contaminated the coolant.

- 1 - Too high pressure read on low pressure gauge.
- 2 - Too high pressure read on high pressure gauge.
- 3 - Some bubbles appear in the filter indicator.

Conclusions:

Air and/or moisture in the system and non-condensable fluids which have contaminated the coolant. Drain, change drier filter and recharge the unit.

8th Case

Insufficient cooling due to faulty operating of the expansion valve.

- 1 - Too high pressure read on low pressure gauge.
- 2 - Too high pressure read on high pressure gauge.
- 3 - Evaporator delivers too warm air.
- 4 - High moisture condensation on the intake pipe and on evaporator.

Conclusions:

The expansion valve lets pass an excessive flow of coolant through the evaporator. Check and replace the valve, if necessary. Make sure that the thermic connections of valve capillary with evaporator pipe is not disconnected or corroded.

9th Case

Insufficient cooling due to faulty operating of the expansion valve.

- 1 - Too low pressure on low pressure gauge.
- 2 - Too low pressure on high pressure gauge.
- 3 - Evaporator delivers air scarcely cool.
- 4 - Moisture condensates or freezing on the inlet pipe of expansion valve.

Conclusions:

Freon flow obstructed in the expansion valve. High condensing or freezing on inlet pipe, clogged valve filter, warm valve top, the valve nozzle is closed or the bulb has lost the thermostatic fluid. Check and, if necessary, change the valve.

10th Case

Obstruction in the high pressure lines; evaporator partially cooling.

- 1 - Too low pressure on low pressure gauge.
- 2 - Too low pressure on high pressure gauge.

This case, like the previous one, indicates a limited coolant flow and the high pressure is lower than usual. The compressor sucks more coolant than the quantity that could enter into the evaporator thus determining a too low pressure on the low pressure gauge. Condenser and drier will operate as freon reservoirs. The remarkable flow of air delivered by the fan, will freeze the coolant stationary in the condenser and the high pressure gauge will indicate a decrease in pressure. If, on the contrary, the circuit is overcharged with freon the high pressure gauge will indicate a normal pressure or, more frequently, excessively high pressure. This last case, will occur if the obstruction is appeared upstream of the drier filter.

Conclusions:

Drier or other parts of the circuit obstructed. The drier is jammed or partially clogged due to rubber particles detached from the pipes.

OPERATION OF CONTROLS

With the engine running, turn the knob 2 clockwise to speed 1. In this way the compressor 10 and the right ventilator 6 of cooling radiator are ready to operate. Rotating the knob 3 clockwise to speed 1, magnetic clutch dragging compressor, fan motor 6 and evaporator fan 7 are engaged.

Operate on knob 3 to regulate air volume while, to regulate cold intensity, operate on knob 2.

Do not keep knob 2 to limit switch (max) for a long time to avoid icing-up on evaporator unit.

WARNING

In order to have a correct operating of the system, shut levers 20 and 22 (fig. 1). Two switches for min. and max. pressures are fitted in the system and they disconnect the compressor when the pressure reaches too high or too low values (as in case of discharged system). Should air circulation be required when the engine is stationary, the fans of the evaporator can be left running. The two fans are controlled by knob 54.

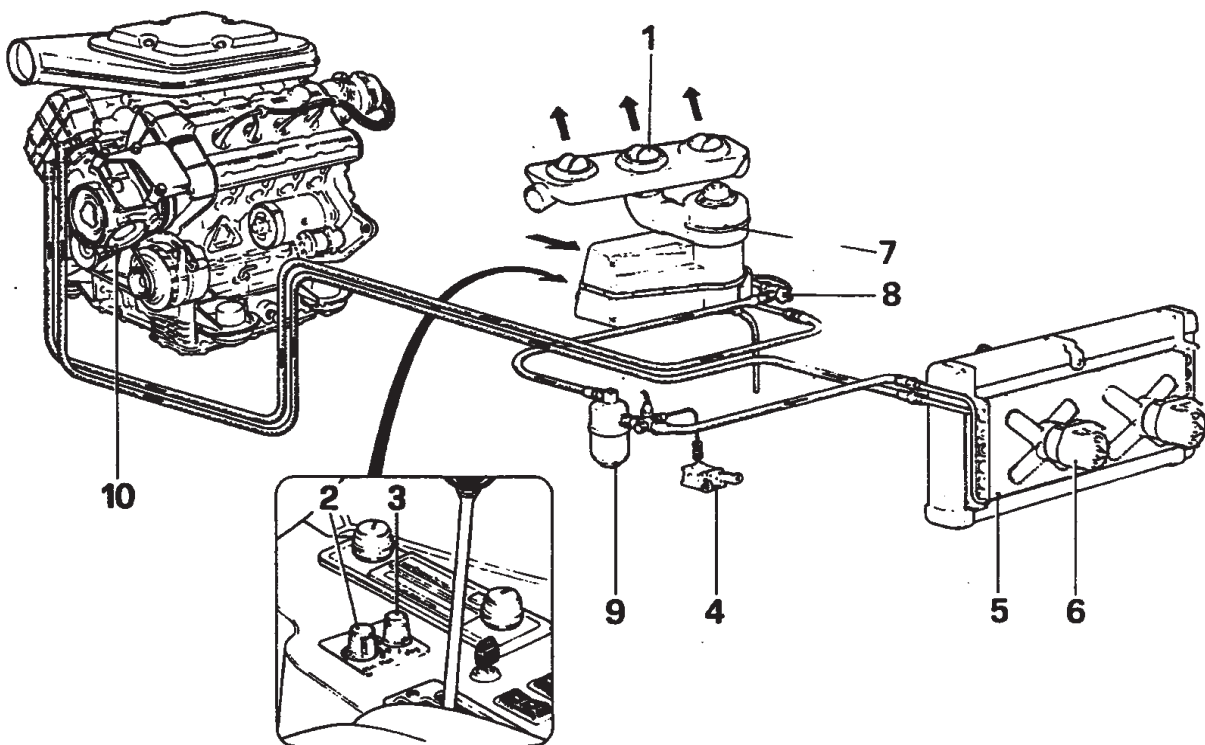

Fig. 4 - LAYOUT of AIR CONDITIONING UNIT.

1 - Adjustable outlet vents; 2 - Temperature control knob for A.C.; 3 - Air flow control knob; 4 - Pressure switch; 5 - Condenser; 6 - R.H. radiator fan; 7 - Evaporator unit; 8 - Expansion valve; 9 - Drier; 10 - Compressor.

MAINTENANCE INSTRUCTIONS

Normal maintenance is limited to the following periodical operations:

- A complete change of FREON once a year, providing that no leaking occurs.
- Check oil level in compressor every 20.000 km.
- Check compressor control belt tension.

For having these operations effected, or in case of irregular functioning of the air conditioning unit, a BORLETTI's or a VOXON's Dealer should be contacted.

Otherwise, apply to Ferrari Authorized Services.

OPERATING INFORMATION

IMPORTANT INSTRUCTIONS

COMPRESSOR ASPERA Frigo HG 700 AP

- Before fitting the compressor on the suitable support, place it on two small wooden blocks with the control shaft turned downward but avoid that the shaft ends lean on the support since any load should never lay heavy on the shaft: leave it in this position for 30'. This operation is essential to allow a perfect lubrication of shaft seal gasket before compressor operates.
- The manufacturer supplies the compressor properly lubricated and with an exact quantity of oil for a regular operating. Should different brands of oil be added, this will pollute the whole system thus voiding the warranty terms on compressor and all other parts involved.

USE ONLY AGIP TER 54 OIL or SUNISO G 4 OIL

- The oil level in compressor should be checked before fitting the unit on its support; take off one of the lateral plugs and measure the level with a dipstick. Make sure of correct plugs closing. In a new compressor, the oil level should be 38 ± 40 mm. After operating, it should be within 22 ± 29 mm.

ELETTROLOCK ELECTRO-MAGNETIC CLUTCH

- Fit the electro-magnetic clutch on the compressor shaft before fitting the compressor on its support. Effect this operation with the utmost care then tighten the shaft bolt.

INSTALLATION

- During the installation of the air conditioning unit or when the connections are not well tightened, do not use water near the system for any reason. Water can be poured only on the condenser to reduce the head when effecting the vacuum, charge or setting operations.
- Do not remove the plastic plugs of the flexible pipes or fittings until ready to assemble the unit. This simple expedient will prevent the entering of moisture and dirt which could affect the reliability of the system.
- Take care not to remove the plugs from the drier until the connections with the other parts can be done. If this unit is left open, it saturates with moisture thus badly affecting the system operating. If, for any reason, the installation of the air conditioning unit is to be interrupted for some hours, close all flexible pipes and, above all, the drier pipe unions.
- Do not spread any sealing compound on the flexible pipes unions but slightly grease them with oil for compressor units.

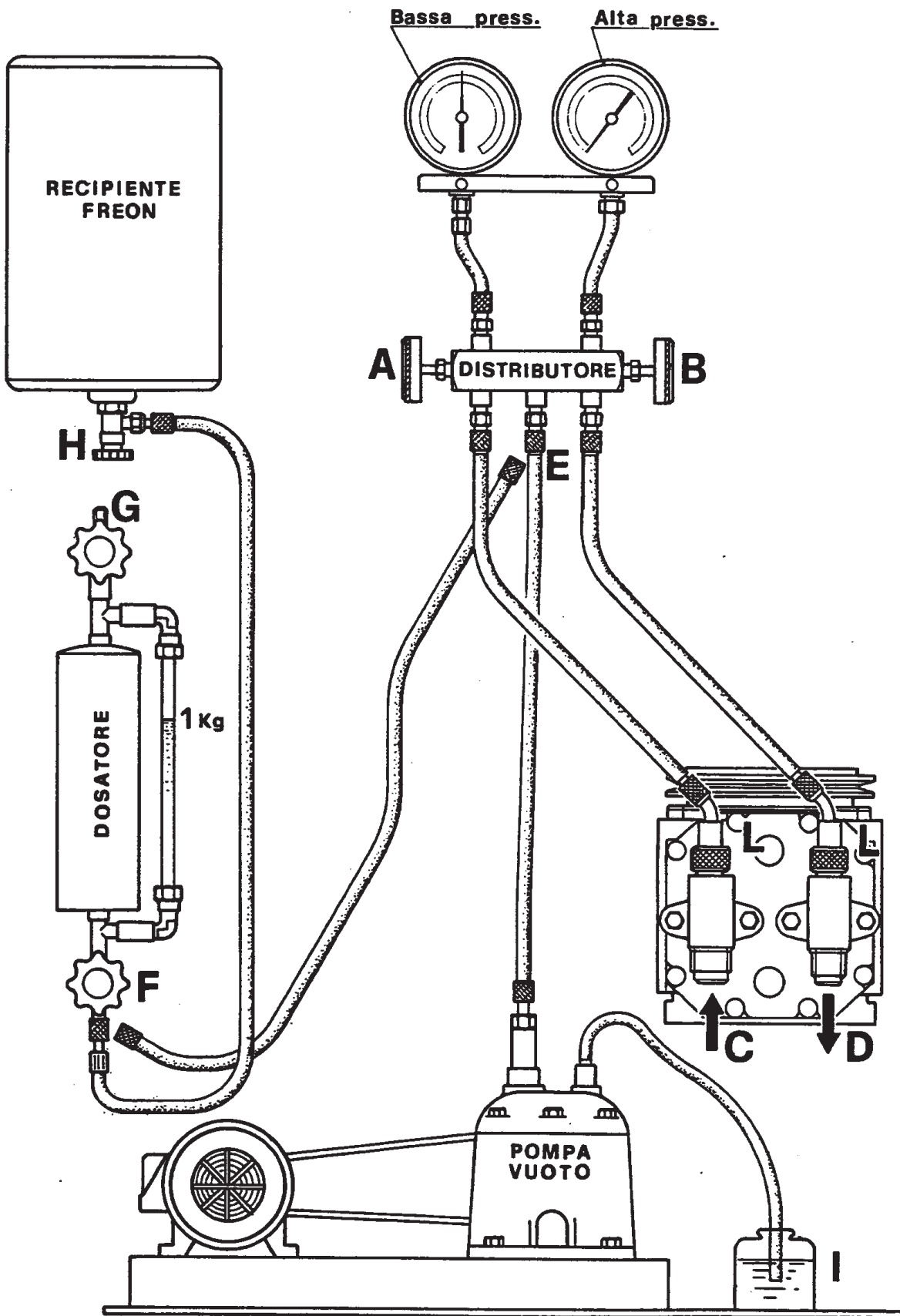

Fig. 5 - DEVICE for SYSTEM RE-CHARGE.

- When reassembling the pipes, the use of two wrenches is recommended in order not to twist the lines together.
- If there are great Freon leakages causing the complete discharge of the conditioner unit, change the cleaner as it is probably saturated with moisture.
- It is no use to drain a unit which still contains Freon but locate the leakage, if possible, and repair it without disassembling the unit. Then, complete the charge adding some more Freon.
- Avoid any excessive stress of compressor belts while removing and reassembling the unit.
In case the compressor adjuster does not allow a correct belt tensioning, move the compressor upwards and reduce the spacers which are between compressor and support.

PRELIMINARY OPERATIONS BEFORE SYSTEM RECHARGING

NECESSARY TOOL EQUIPMENT

- Motor-pump unit for vacuum.
- A graduated cylinder to measure and charge Freon, with visible level and index which should correspond to 1 kg. of Freon, taps, union and pipes (fig. 5).
- Distributor device with pressure gauges, auxiliary pipes and taps for high and low pressure.

The gauges unit consists of:

- Vacuum gauge with graduation from zero to 760 mm. of mercury for vacuum and graduation from zero to 10 kg/cm² for low pressure.
- Gauge with graduation from zero to 35 kg/cm² for high pressure.
- Leaking indicator.
- AV 965 tool for compressor auxiliary valves.

COMPRESSOR AUXILIARY VALVES

The compressor valves are of the needle, self-closing type. Therefore, when draining the system (by vacuum pump) and when filling it, use the special tool AV 965 which holds the valve open.

The suction valve is larger in diameter and is connected to evaporator return pipe. The smaller valve, for delivery, is connected to the condenser.

DRAINING THE SYSTEM BY VACUUM PUMP

- Make sure that engine and air conditioning unit are cold.
- Connect the compressor high pressure valve to the gauges group and this to the vacuum pump.
- Open the high pressure tap of gauges manifold and make sure that the low pressure tap is correctly closed.
- The pump should operate for 30' at least to discharge air from the pipes; check pressure on gauge. The system should reach a vacuum of 710 ± 750 mm. Hg. in less than 5'.
- Put the outlet pipe end into a container filled with compressor oil. Any bubbles should not appear. Bubbles can be formed in case of leaking system. In order to eliminate any possible leakage, check pipes and unions and, possibly, the whole system; charge it partially. Afterwards, effect again the aforementioned operations.
- Close the high pressure tap manifold gauges.
- Stop the vacuum pump.
- Make sure that gauge pressure does not increase faster than 25 mm. Hg. every 4-5 minutes.
- If system sealing condition is regular, effect the charge operation.

RECHARGING THE SYSTEM THROUGH A GAS STATION

A) FILLING THE GRADUATED CYLINDER.

- 1 kg. of Freon is enough to charge the system completely.
- Connect the graduated cylinder union to the main bottle then open the bottle tap.
Loosen and tighten the connection on the cylinder to allow air discharge from the relevant pipe.
- Await until a steady fluid level is noticed in the graduated cylinder. If the cylinder is not filled up to the index, this indicates an excessive back pressure. Therefore, let bleed, at very short intervals, the upper tap located on the cylinder.

B) CHARGING THE SYSTEM.

- Connect the cylinder to pressure gauge manifold allowing the air bleeding from the connecting pipe.
- Tighten the manifold union and open the tap of high pressure union. Await until the graduated cylinder is empty.

COMPLETE CHARGE OF THE SYSTEM

- In order to effect a faster recharge of the system, heat the Freon reservoir with an electric resistance until the inner pressure reaches 7 + 8 Atm. For safety's sake, connect the reservoir to a pressure gauge and to a pressure switch or to a safety valve so the pressure will not exceed the prescribed values since an excessive pressure could cause the explosion of the reservoir.

WARNING - Every 7°C of heating, the pressure increases of approx. 1 Atm.

LOOKING FOR POSSIBLE LEAKAGES

In case the system loses in charge, locate the leaking unions. For this, use a leakage detector equipped with a rubber tube of approx. 1 meter in length.

- Engine must not run and the fans nearby the system must be stationary. Effect this operation with the car in a non-ventilated place since the air could blow the Freon off thus making more difficult the research operation.
- Pass the tube end of the detector around all connections, the valve on compressor and around the rear part of clutch unit to check the seal of the compressor shaft gasket.
- The blue flame of the detector becomes green when the 'sniffing tube' gets in touch with Freon.

WARNING - Keep the torch far from the face and do not smell gas. Also, keep it far from the carburetors, gasoline reservoirs and the painted parts of the vehicle.
Repair any leakage and drain the system.

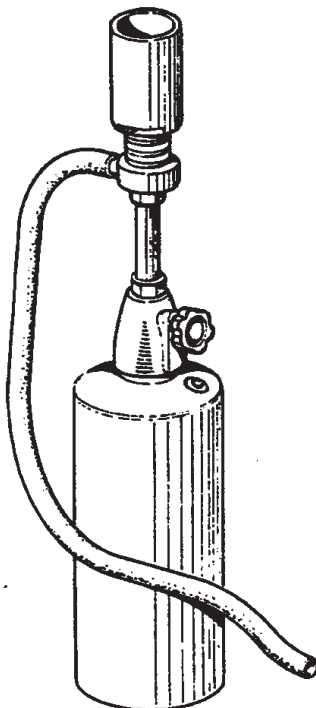

Fig. 6 - LEAKAGE DETECTOR.

ADJUSTMENT OF COMPRESSOR CONTROL BELT TENSION

(Check tension with cold engine).

TENSION MANUAL CHECKING

The deflection C of the belt in the middle of the two pulleys does not exceed 3 mm. with a load of 2 kg.
Load must be of 1 kg. for a run-in belt.

CHECKING BY TENSIO METER

The tension charge of a new belt should be 22,5 kg. read on scale 11 M of tensiometer. 'Gates 150 type'.

With used belt the tension should be 19 kg. To increase the belt tension, it is necessary to slaken the nut D which tightens the support of the idler.

Move the support counterclockwise and retighten the nut.

WARNING

During these operations, or less frequently, visually check the belt condition.

Do not exceed in tensioning the belts to avoid any abnormal stress of the compressor bearings.

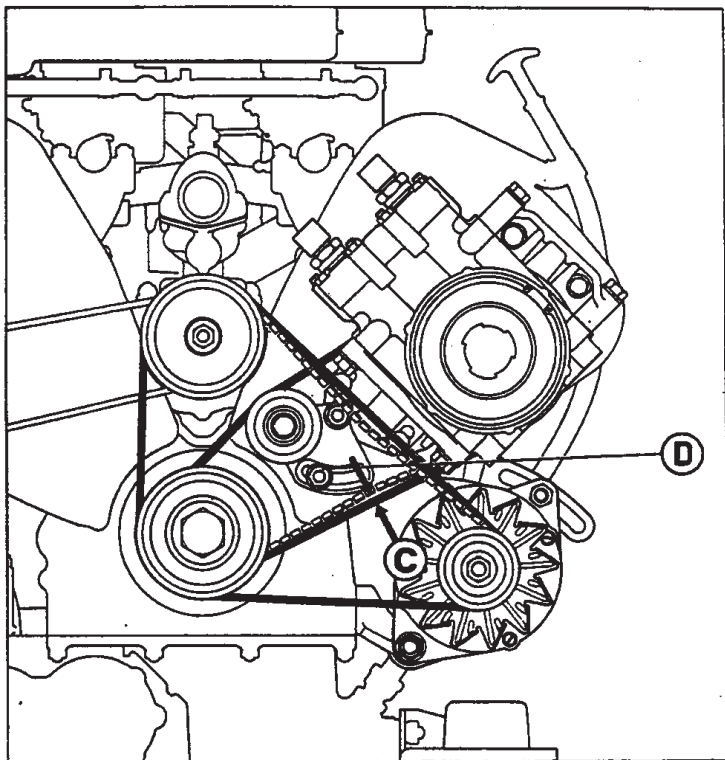

Fig. 7 - BELT TENSION.

SECTION

L

**ELECTRIC
SYSTEM**

	Page
BATTERY AND ALTERNATOR	L 3
MAIN SPECIFICATIONS	L 3
CHECKINGS AND SERVICE	L 3
CHARGING SYSTEM	L 4
STARTER MOTOR	L 6
SPECIFICATIONS	L 6
TROUBLES AND REMEDIES	L 7
GENERAL INFORMATION	L 9
MAINTENANCE	L 9
IGNITION SYSTEM	L 10
SPECIFICATIONS	L 10
TROUBLES AND REMEDIES	L 11
IGNITION DISTRIBUTOR	L 12
IGNITION COILS	L 16
SPARKING PLUGS	L 16
LIGHTING SYSTEM	L 18
MAIN SPECIFICATIONS	L 18
HEADLAMPS	L 19
FUSES AND RELAYS	L 22
WIRING DIAGRAM	L 24

BATTERY AND ALTERNATOR

MAIN SPECIFICATIONS	Page L 3
INSPECTION AND MAINTENANCE	" L 3
ELECTROLYTE LEVEL	" L 3
CHECKING BATTERY CONDITIONS	" L 4
POSSIBLE CAUSES OF ABNORMAL BATTERY DISCHARGE	" L 4
RECHARGE SYSTEM	" L 4
ADJUSTMENT OF ALTERNATOR BELT TENSION (see page C 9).	

MAIN SPECIFICATIONS

BATTERY	
Nominal capacity	Ah 60 or Ah 66
Nominal voltage	12 V
ALTERNATOR	
Type	BOSCH 0.120.489.542
Nominal voltage	12 V
Setting voltage	14 V
Maximum current	55 A
Cut-in speed	1000 RPM
Max. steady speed	12000 RPM
Armature resistance	0,13 Ω + 10%
Field resistance	4 Ω + 10%

The electric system operating depends mainly on battery full efficiency, therefore it is a good habit to ensure that battery is always in good conditions and periodically carry out a careful checking. Battery, when fitted, must be well fixed on a horizontal surface thus avoiding any shifting or hopping.

INSPECTION AND MAINTENANCE

Battery must be always clean and dry, mainly the upper part. Check that there is no slit on the fix cover of battery since electrolyte leaks could appear. Avoid any electrolyte leakage since this may produce corrosions. The caps of each cell must be carefully screwed; any broken part must be immediately replaced. Clamps must be carefully tightened to terminals and spreaded with pure vaseline to avoid oxidation.

ELECTROLYTE LEVEL

Only water, because of its evaporation, must be added into battery. Electrolyte level must be checked every 5000 km.; in summertime it should be checked more frequently.

The electrolyte level should exceed for some millimeters the upper rim of the cells; it should not exceed, however, more than 5 mm.

CHECKING BATTERY CONDITIONS

Check battery charging conditions measuring with a densimeter the electrolyte. Battery is charged when the electrolyte density in each cell is within 1270 / 1280 gr/lt.

When the density is 1150 gr/lt. or less, battery is discharged: in this case re-charge it following the subsequent instructions:

- Remove battery from car.
- Carry out a careful cleaning, mainly in the cell upper part.
- Remove caps and check that electrolyte level exceeds 4 + 5 mm. the upper rim of separators.
- Put battery in charge circuit.
- Use a current intensity of 5 Amperes and go on charging until:
 - a) the density of electrolyte reaches the value of 1270+1280 gr/lt. (30 + 31 Bé);
 - b) the value of density is constant for three consecutive readings with one hour distance from each other;
 - c) the value of each cell tension is constant for three consecutive readings with one hour distance from each other;
 - d) a lively ebullition of the electrolyte takes place in each cell.

If the car is to be left stationary for a long time, check the battery every two months and recharge it when the density is below 1200 gr/lt.: this will avoid a complete discharge and consequent sulphation of the plates which will completely damage the battery. If, after charging the battery, an unequal concentration of electrolyte in the cells is noticed, this means that there is a failure coming from a broken cell or a shorted plate.

WARNING

It is dangerous to pour water into acid as well as to light a flame or to sparkle nearby the battery, mainly during the charge operation.

POSSIBLE CAUSES OF ABNORMAL BATTERY DISCHARGE

Insufficient charge due to bad efficiency of alternator.

Excessive discharge: generally, this is due to too frequent and consecutive starting operations or to a long use of lamps with the engine out.

Electric leakages due to insulating faults in the electric system.

CHARGING UNIT WITH BOSCH ALTERNATOR

This unit is composed of an alternator, a voltage regulator incorporated in the alternator, and a warning light for battery poor charge. The following information refers to:

- Alternator: BOSCH O.120.489.542 (55 Amperes).
- Voltage regulator: BOSCH O.192.052.004.
- Warning light for battery poor charge.

The stator functions as an inducer, the rotor as an inductor. The rotor mounts the energizing coil in which flows the direct current supplied through two sets of brushes and a two ring commutator; the energizing coil generates the magnetic field necessary to lead the alternating voltage in the stator.

The stator is composed of a laminated body in which is installed a three-phase delta connected winding. From the vertices extend three wires connecting the delta winding with the rectifier group.

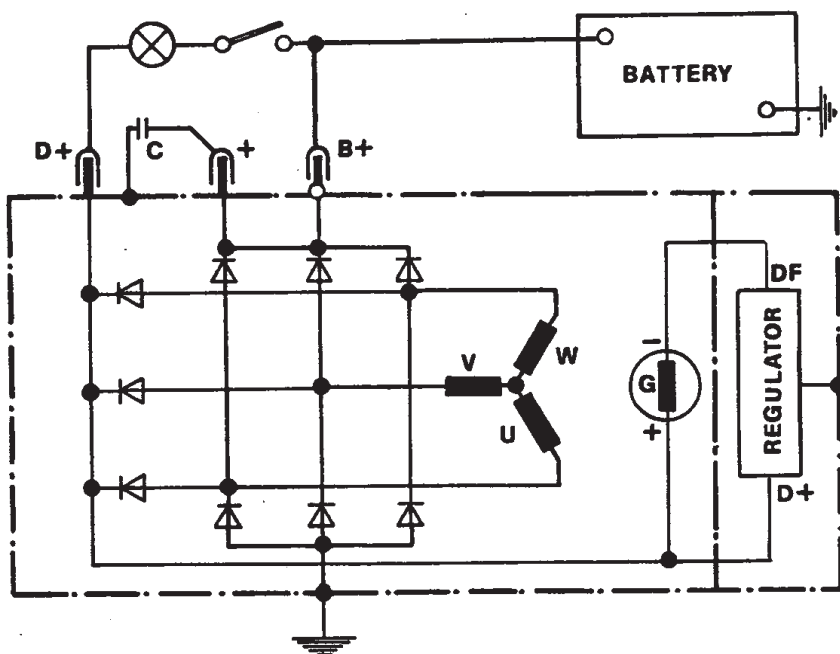

Fig. 1 - ELECTRIC DIAGRAM of ALTERNATOR and RECHARGE SYSTEM.

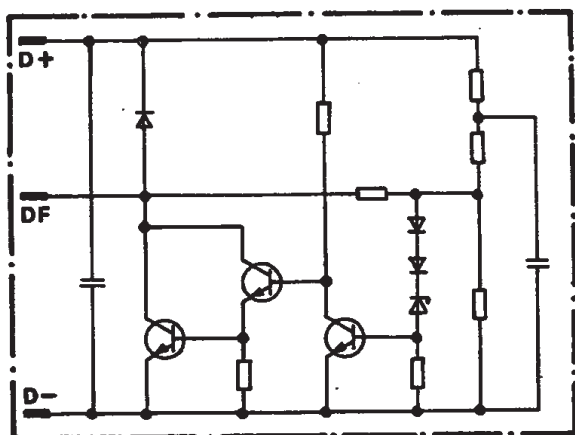

Fig. 2 - ELECTRIC DIAGRAM of VOLTAGE REGULATOR.

CHECKING OUTPUT FEATURES

When possible, a checking of output features allows us to make completely sure of the alternator operating conditions. Fasten the alternator with fan on a test bench which can offer the possibility to change speed continuously.

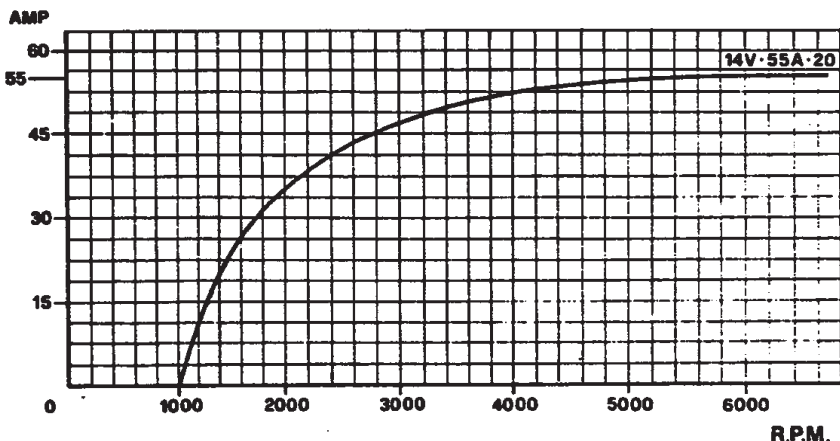

Fig. 3 - DIAGRAM of CURRENT OUTPUT.

STARTER MOTOR

MAIN SPECIFICATIONS	Page L 6
TROUBLES DIAGNOSIS AND REMEDIES	" L 7
GENERAL INFORMATION	" L 9
MAINTENANCE	" L 9

MAIN SPECIFICATIONS

Type	F 4162784 or BOSCH 0.001.314.006	
Voltage	12 V	12 V
Nominal power	1,5 kw	1,4 CV
Direction of rotation (pinion side)	right-handed	right-handed
Pinion drive	free-wheel type	free-wheel type
Control	electro-magnetic	electro-magnetic
- Stall torque		
Current	A 540 ± 20	A 690 + 780
Voltage	V 6,6 ± 0,1	V 6
Torque developed	kgm. ≥ 2	kgm. 2,3
- No load test		
Current	A 30 ± 5	A 50 + 80
Voltage	V 11,7 ± 0,1	V 11,5
Speed	4800 ± 20 RPM	7300+9300 RPM
Lubrication		
- Splines of drive unit and shaft washers	Agip SINT 2000 SAE 10 w 50	
- Sleeve and disc	Agip F1 GR Mu/EP2	

TROUBLES DIAGNOSIS AND REMEDIES

MOTOR DOES NOT TURN

POSSIBLE CAUSES	REMEDIES
1) Battery terminals corroded.	1) Remove terminals, clean them carefully, reassemble and coat them with pure vaseline.
2) Starter switch or battery terminals loose.	2) Check and tighten if necessary.
3) Battery flat.	3) Check state of charge and, if necessary, locate leak.
4) Worn brushes not contacting commutator.	4) Change brushes for approved type.
5) Starter switch contacts corroded, worn or dirty.	5) Check and clean contacts; corrosion may be caused by short-circuited turns due to over-current.
6) Armature or field windings earthed.	6) Faulty insulation or damaged segments. Change defective parts.
7) Solenoid coil interrupted.	7) Change solenoid.

MOTOR STARTS but RUNS VERY SLOWLY

POSSIBLE CAUSES	REMEDIES
1) Worn brushes.	1) Change brushes.
2) Part of field or armature winding shorted.	2) Locate shorted turns with H.F. equipment.
3) Battery terminals corroded.	3) Take off terminal nuts, clean terminals, replace nuts and coat with pure vaseline.
4) Starter switch or battery terminals loose.	4) Check and tighten terminals if necessary.
5) Battery charge very low or one or more plates defective.	5) Check state of battery charge or change it if necessary.
6) Armature winding earthed.	6) Change armature.

STARTER MOTOR VERY NOISY WHEN RUNNING

POSSIBLE CAUSES	REMEDIES
1) Self-lubricating bushes excessively worn.	1) Change bushes.
2) Pinion disengagement unduly late.	2) Fault in engagement mechanism due to dirt or jamming of lever, weak spring, wear in sleeve or solenoid core. Dismantle motor and change parts as necessary.

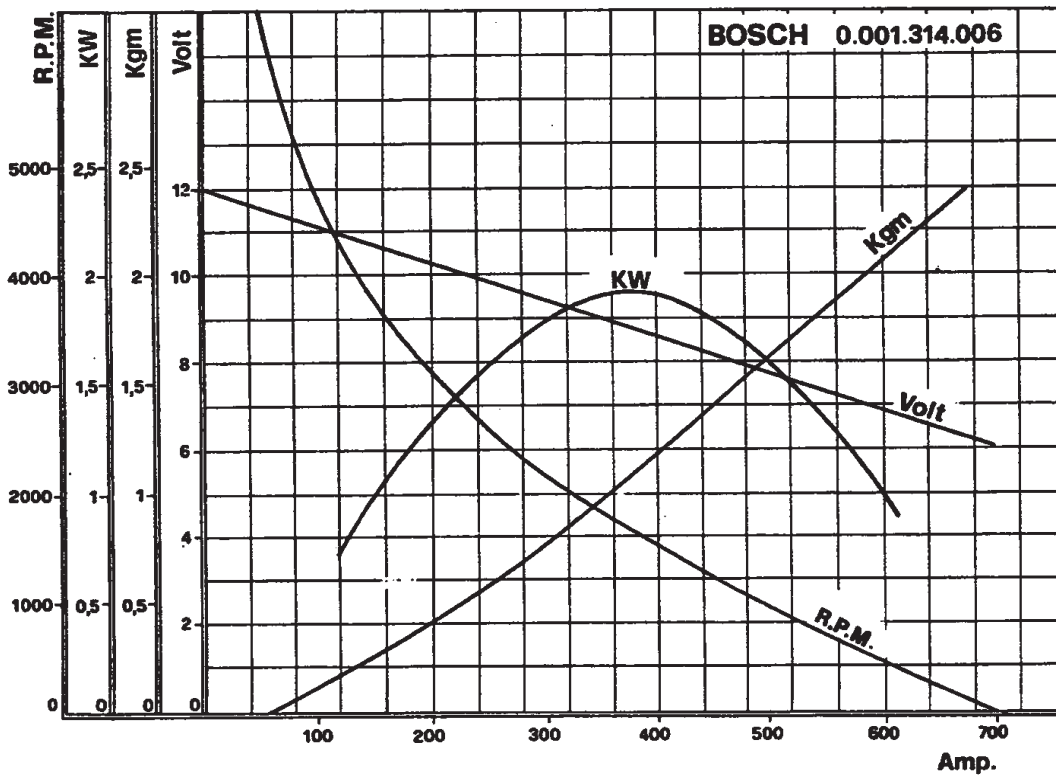
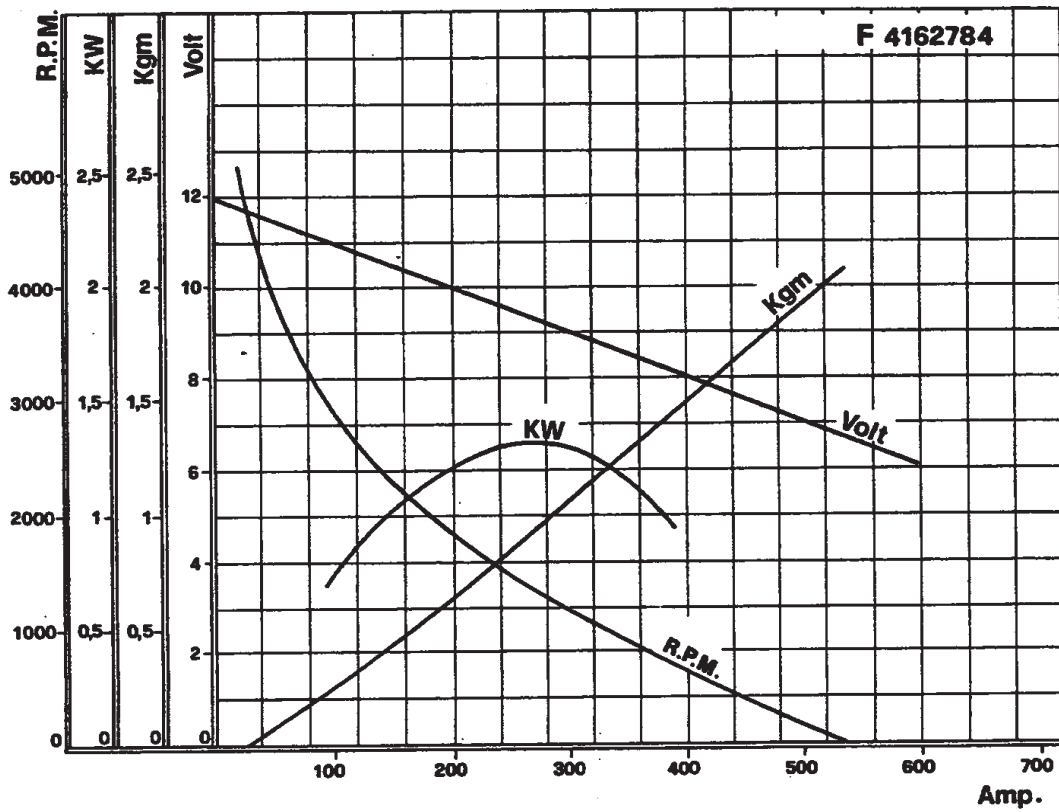

Fig. 4 - CHARACTERISTIC CURVES of STARTER MOTORS F 4162784 and BOSCH 0.001.314.006.

GENERAL INFORMATION

The driving of the pinion starting motor is actuated by a combined thrust and helical clutch; the movement control is electrically provided by an electro-magnetic switch.

MAINTENANCE

Before handling any maintenance operation on the starting motor, it is indispensable to remove the positive cable which connects it to the battery.

Clean periodically the pinion and flywheel gear teeth, grease sparingly using a small brush.

Check the condition of the commutator and that of the brushes.

If the commutator is dirty, clean with a piece of cloth soaked in gasoline and apply dry air to remove carbon and copper dust from the commutator laminations. Raise brush springs (without distorting) and check brushes in proper holders. Wipe brushes and holders with gasoline wet cloth if they do not slide freely.

The motor is mounted on porous and self-lubricated type bushings and does not require any lubrication.

In case the starting motor should be disassembled for an overhauling operation, clean all components properly before reassembling.

If the commutator shows any burnt spots or deep scores, it is necessary to turn it on a lathe. The reducing value on the diameter should not exceed $0,5 + 0,6$ mm.

After the turning operation, undercut the mica segments to a depth of approx. 1 mm., then clean thoroughly.

If the brushes are worn, they should be replaced with the original type and size.

Even when only one of the brushes results worn, it is advisable to replace both.

After replacing them, run the motor without load in order to adapt the brushes adherently to the commutator surface.

When assembling, make sure that all components are electrically insulated (armature, commutator, field coils, brush holders, etc.).

IGNITION SYSTEM

MAIN SPECIFICATIONS Page L 10
 TROUBLES DIAGNOSIS AND REMEDIES " L 11
 IGNITION DISTRIBUTOR " L 12
 GENERAL INFORMATION " L 12
 OPERATING INFORMATION " L 12
 RETARDED IGNITION " L 13
 BREAKER POINTS SYNCHRONIZATION. " L 14
 CHECKING AUTOMATIC ADVANCE CURVE " L 15
 IGNITION COIL " L 16
 CHECKING " L 16
 BENCH TESTING " L 16
 SPARK PLUGS " L 16
 INSPECTIONS " L 16

MAIN SPECIFICATIONS

IGNITION DISTRIBUTORS	
Type	MARELLI S 159 A
Static advance setting	6° on R2
Distributor automatic advance	13° ± 1°
R1 contacts gap	mm. 0,35 ± 0,03
R2 contacts gap	mm. 0,35 ± 0,05
Breaker contact pressure	gr. 950 ± 100
Opening angle R1	56° ± 3°
Closing angle R1	34° ± 3°
Opening angle R1 and R2 in parallel	51° ± 3°
Closing angle R1 and R2 in parallel	39° ± 3°
Phase difference	5° ± 30'
IGNITION COILS	
Type	MARELLI BZR 201 A
Primary winding ohmic resistance at 20°C	3,1 + 3,4
Secondary winding ohmic resistance at 20°C	5500 ÷ 7000
Insulation resistance to earth at 500 V.	c.c. 50
SPARK PLUGS	
Type	CHAMPION N 7 Y or BOSCH W 200 T 30
Electrodes gap	mm. 0,4
Thread	mm. 14 x 1,25
Tightening torque	kgm. 2

TROUBLES DIAGNOSIS AND REMEDIES

IGNITION NOT WORKING AT ALL

POSSIBLE CAUSES	REMEDIES
1) Battery charge too low. 2) Current circuit disconnected or earthed.	1) Recharge battery or replace. 2) Check and repair circuit.

IGNITION DEFECTIVE

POSSIBLE CAUSES	REMEDIES
1) Condenser shorted or with low insulation resistance. 2) Breaker points closed or dirty. 3) Distributor caps cracked and carbonised inside or very damp. 4) Rotors cracked or carbonised. 5) Carbon brushes with weak springs. 6) Rotors seized on pins. 7) Contact return spring weak. 8) Contacts opening too wide. 9) High voltage connections discharging or not steady.	1) Secondary voltage too low; weak spark. Strong spark between contacts. Change the condenser. 2) Adjust breaker points and clean contacts. 3) Change caps if cracked; clean breaker points. 4) Change rotors if cracked. Clean breaker points and replace rotor if the gap is more than 0,3 mm. 5) Replace carbon brushes and spring; clean brush contact. 6) Lubricate pins with vaseline oil. 7) Springs deformed. 8) Weak spark, especially at high engine speeds. Adjust points as per table page L 10. 9) Check terminals and wires.

IGNITION TOO ADVANCED

POSSIBLE CAUSES	REMEDIES
1) Defective microswitch. 2) Centrifugal advance spring weak. 3) Contacts excessively worn. 4) Incorrect setting between R1 and R2.	1) Check that R2 at idle is earthed. If necessary, change the microswitch. 2) Check advance curve and overhaul distributor, if necessary. 3) Change contacts carrier unit. 4) Bench test contacts.

RETARDED IGNITION

POSSIBLE CAUSES	REMEDIES
1) R2 retarded contact always earthed. 2) Ineffective automatic advance.	1) Check microswitch and change it if necessary. Check electric connections from distributors to microswitch. 2) Check advance curve. Overhaul distributor if necessary.

RETARDED IGNITION (continuation)

POSSIBLE CAUSES	REMEDIES
3) Guide shoes of breaker points worn.	3) In case of excessive wear, change the points of the two groups. Otherwise, adjust breaker points gap.
4) Excessive clearances in distributor control components.	4) Check clearances and change worn parts.

IGNITION COILS FAULTY

POSSIBLE CAUSES	REMEDIES
1) Loose or dirty connections.	1) Clean and tighten connections.

If there is any other fault in the ignition coil, change the coil.

IGNITION DISTRIBUTOR

GENERAL INFORMATION

This distributor is of the type studied for sport and racing cars having 4 to 8 cylinders and 12 volts electric system. The rotor unit is a cam 4 lobes type with two contact breaker points $185^\circ \pm 30'$ off-set. The first contact (R1) is earthed on the distributor while the second one (R2) is insulated and the current flow is provided by a microswitch which is operated by the accelerator pedal. The contact breaker points are fixed to the distributor by screws and slots in order to allow the exact rotors synchronization.

OPERATING INFORMATION

As shown in the wiring diagram (fig. 5), the closing of the switch (4) (which is the starting and ignition switch located on the dashboard), provides an electric circuit which is called primary current circuit: the current circulates in the ignition coils (3) primary winding then it passes through the rotor contacts and returns back to the battery through the earth of the vehicle chassis.

The current circulating through the primary winding, provides a magnetic flux and the relevant lines of force link with the secondary winding.

When the cams (10) open the rotor contacts, interrupting in this way the primary current circuit, the magnetic flux becomes zero. Because of the magnetic induction, high tension impulses are provided in the secondary winding thus causing sparkling between the electrodes of the spark plug. The high tension current is delivered by proper H.T. wires to the spark plugs through the distributor (11).

The condensers (5) have the function to make stronger the current interruption and, in the meanwhile, they act as spark arrester.

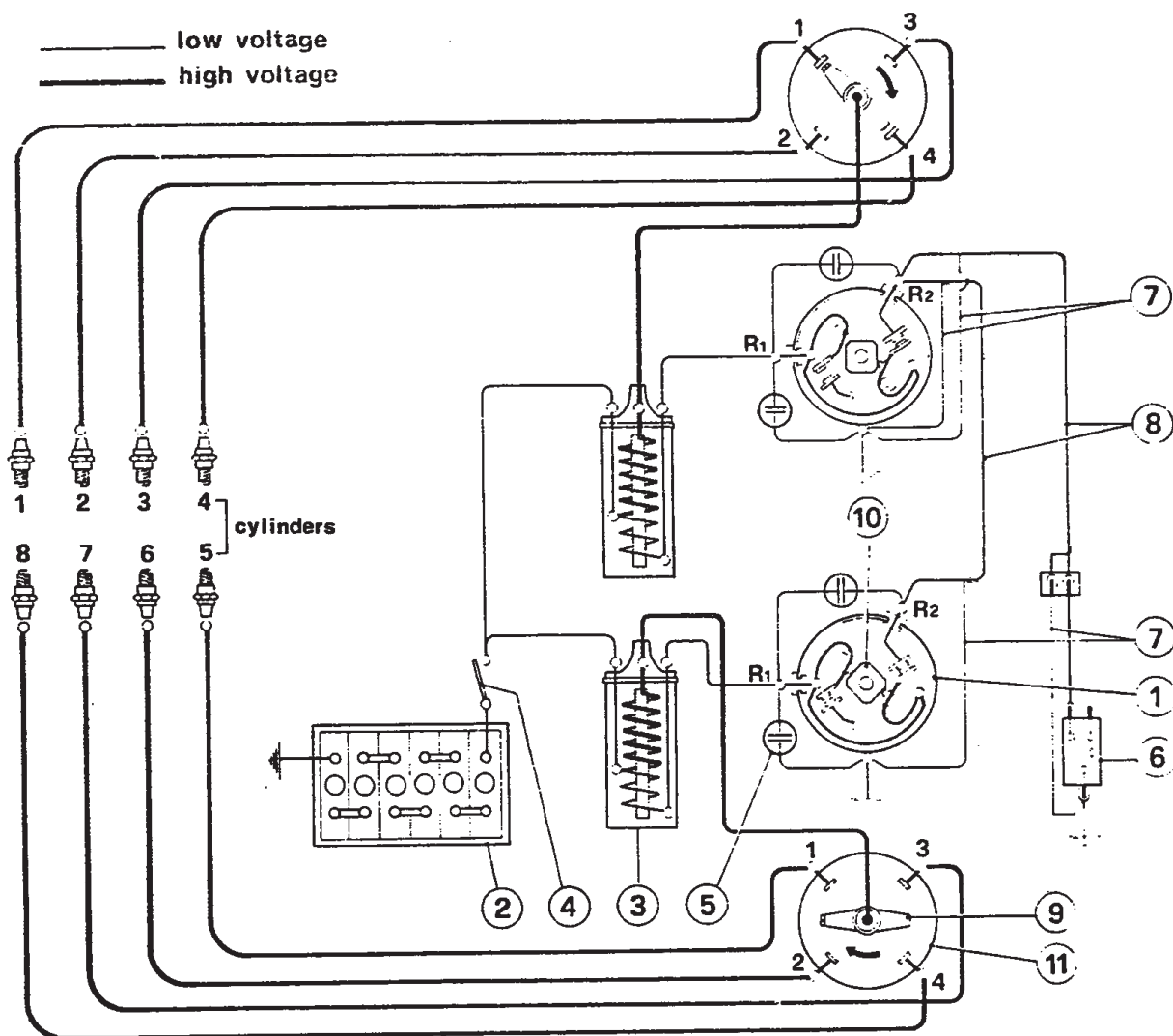

Fig. 5 - LAYOUT of IGNITION CIRCUIT.

1 - Distributors; 2 - Battery; 3 - Coil; 4 - Ignition switch; 5 - Condensers; 6 - Microswitch; 7 - Earth for radio noise suppressor screening; 8 - Screened unipolar cable; 9 - Rotor arms; 10 - Distributor cam; 11 - Distributor cap.

RETARDED IGNITION

When the distributor contacts are correctly synchronized, one in relation to the other, the cam rotation opens R1 contacts and, after a further rotation of $5^{\circ} \pm 30'$, opens R2 contacts too.

During slow running operation, R2 is earthed through the microswitch. When R1 contacts open, the current in the primary circuit does not interrupt but it passes through the distributor by means of R2. It is necessary that the distributor shaft rotates further for $5^{\circ} \pm 30'$ so even R2 contacts open and the current flow breaks, thus firing the spark plugs: in this condition, the spark plug ignition takes place after a rotation of $10^{\circ} \pm 0'$ of the crankshaft in relation to the point corresponding to R1 opening.

When the microswitch is open (that is, during vehicle running), R2 is insulated and the current can pass through the distributor only by means of R1 contacts. Therefore, when R1 opens, the primary current breaks and the spark plugs fire (advanced normal operating).

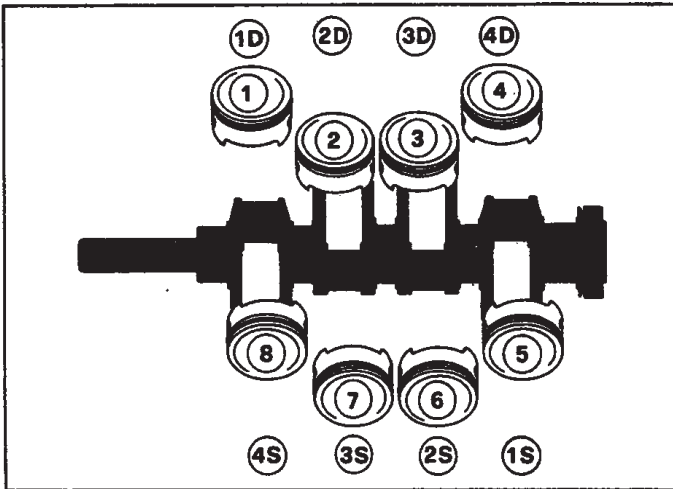

Fig. 6 - PISTONS DISPOSITION.

IGNITION FIRING ORDER:

1 - 5 - 3 - 7 - 4 - 8 - 2 - 6.

BREAKER POINTS SYNCHRONIZATION

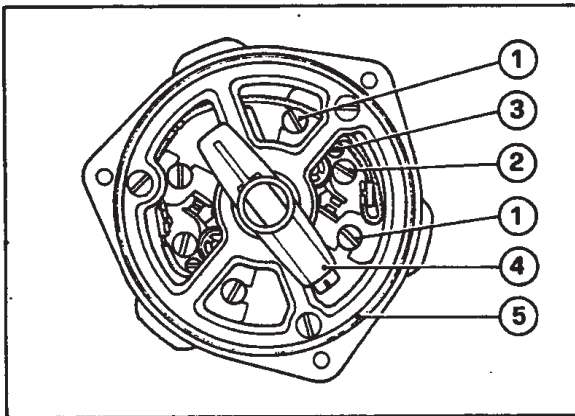

Fig. 7 - IGNITION DISTRIBUTOR.
 1 - Screw fixing the breaker points plate; 2 - Screw fixing contacts plate; 3 - Adjusting screw for contacts opening; 4 - Rotor; 5 - Index on distributor body.

It is advisable to use a suitable distributor tester equipped with stroboscopic device and lamp to check the automatic advance curve and to synchronize the rotors. Act as follows:

- 1st- Set up the distributor, without cap, on the test bench. Settle the distributor in the proper support and connect the control shaft ends to the joint of drive shaft; then make sure that the load on the contacts is within the prescribed values (850 + 1050 grams) checked with the suitable dynamometer. Furthermore, the contacts opening should be exact (see relevant table at page L 10).
- 2nd- Connect the bench low tension connection to R1 terminal.
- 3rd- Rotate by hand (operating direction) the bench scaled disc until the marks on the rotor (4) line up with the mark (5) on distributor body rim. Now, the rotor brush should be in coincidence with the electric connection of cylinder No. 1 wire.
- 4th- Rotate slowly (operating direction) the tester motor equipped with scaled disc and stroboscopic device. Make sure that the opening angle of R1 breaker points is $56^{\circ} \pm 3^{\circ}$ and the closing angle is $34^{\circ} \pm 3^{\circ}$.
After this, check that every ignition takes place at intervals

of $90^{\circ} \pm 1^{\circ}$; this operation ensures of the correct cam profile.

5th- Connect to earth the terminal of R2 contacts; make sure that the same cam lobe opens R2 contacts after $185^{\circ} \pm 30^{\circ}$ the R1 contacts have been opened. If not, operate on screws (1) fixing the breaker points carrier until the correct timing is achieved. Make sure that the opening angle of R1 and R2 contacts in parallel is $51^{\circ} \pm 3^{\circ}$ and the closing angle is $39^{\circ} \pm 3^{\circ}$.

CHECKING THE AUTOMATIC ADVANCE CURVE

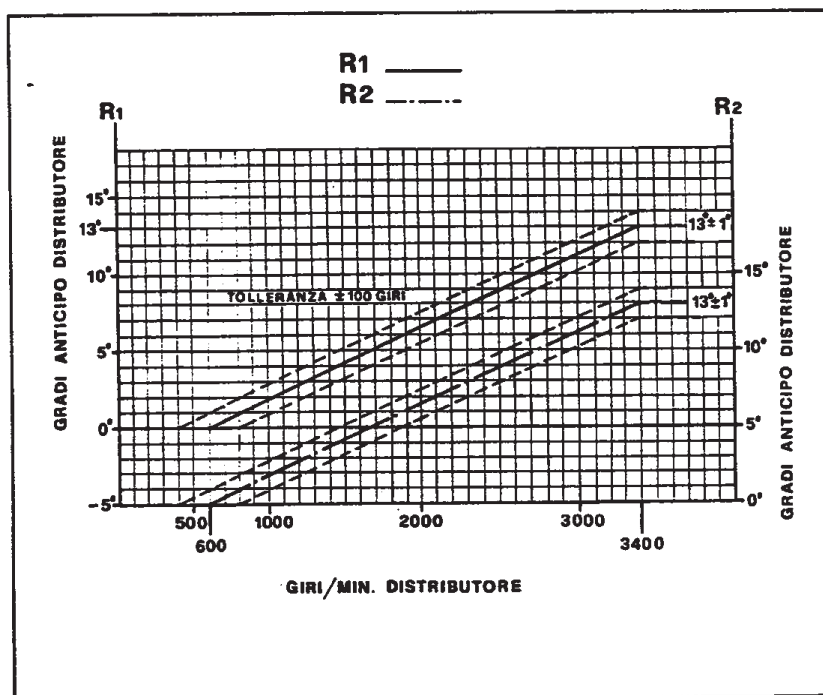

Fig. 8 - DISTRIBUTOR AUTOMATIC ADVANCE CURVE.

After synchronization, the distributor should be tested for automatic advance. If the curve achieved is not equal to that shown in the diagram (fig. 8), replace the counteracting springs. For this operation use the distributor tester equipped with scaled rotating disc and stroboscopic device.

- Rotate by hand the distributor and the scaled disc so that the stroboscopic lamp switch on takes place on zero of the graduation. Start the bench motor and gradually increase the RPM: check at which speed the luminous ignition will start its moving on the scaled disc and, in this condition, the instant in which the advance mechanism starts operating, is achieved.
- Increase again the RPM so the luminous ignition will move to a determined angle which is proportional to the grade of advance and it will increase according to the RPM number until the maximum prescribed value, marked on the advance curve diagram, is reached. The checked values should be within the tolerance limit shown on the diagram.

IGNITION COIL

CHECKING

The ignition coil does not require any maintenance service: only check it, periodically, for its correct operating.

Check the low voltage terminals and relevant connection cables; tighten them correctly if they are loose.

Check the high voltage line and distributor connection: make sure that the cable is correctly held on the bottom of its housing and the high voltage distribution is generated for direct contact, not for jump spark.

Make sure of distributor cap condition; clean it, if necessary, with a rag soaked in gasoline. Replace the coil if the cap present burning areas.

BENCH TESTING

Making the distributor rotate on the suitable test-bench to the prescribed speeds, the following values should be achieved:

- at 90 RPM with input at 8 V :

spark length at cold	10 mm.
spark length at warm	8 mm.

- at 750 RPM with input at 12 V :

spark length at cold	16 mm.
spark length at warm	14 mm.

- at 4000 RPM with input at 12 V :

spark length at cold	10 mm.
spark length at warm	7 mm.

The checking at warm should be effected at least two hours after nominal voltage operating with distributor at 900 RPM.

Each test should last 10 seconds and in this meanwhile the spark should be regular.

The critical length of spark is the minimum spark gap in correspondence of which the sparking is failing.

Dielectric strength: at a temperature of $20^{\circ}\text{C} \pm 5^{\circ}$ the coil withstands at a voltage of 1000 V effective (50 Hz), value applied for three seconds between a primary terminal and the metal envelope; any metal discharge should not take place.

IGNITION SPARK PLUGS

INSPECTIONS

Every 5000 km., or when the engine presents some irregular ignitions, it is necessary to remove the spark plugs to check the electrodes gap, fouling and the sooty deposits produced by the excessive fuel at some engine RPM or by oil entering into the cylinder.

Replace the spark plugs which are very encrusted or smoked. Clean the remaining spark plugs using a steel lamina, wash with gasoline and carefully blow them. Adjust the electrodes gap to 0,4 mm.

To make sure that the spark is efficient between the two electrodes, effect an inspection on the suitable test-bench with the spark plugs under air pressure at $7 + 8 \text{ kg/cm}^2$ and the spark gap of the bench of 8 mm. Should frequent jump sparks be noticed between the spark gap contacts or between the plugs insulation and the earth, replace the

spark plug.

Every 10000 km. replace all the spark plugs.

WARNING - Prior to fitting the spark plugs, make sure that their threads are lightly coated with graphite grease. If the sealing washer is new, first tighten to a maximum torque of 1,5 kgm., then slacken and re-tighten to 2 kgm.

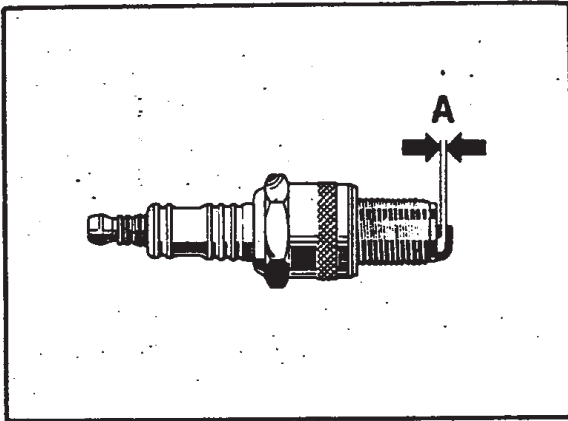

A = 0,4 mm.

Fig. 9 - SPARK PLUG.

L I G H T I N G S Y S T E M

MAIN SPECIFICATIONS	Page L 18
CONTROLS	" L 19
HEADLAMPS	" L 19
DISASSEMBLING	" L 19
EMERGENCY DEVICE FOR LIFTING RETRACTABLE HEADLIGHTS . .	" L 20
RADIO EQUIPMENT	" L 22
FUSES AND RELAYS	" L 22
WIRING DIAGRAM	" L 24

MAIN SPECIFICATIONS

BULBS (use)	TYPE	WATTAGE (12 V)
Headlamp main beam Headlamp dipped beam Anti-fog lights	Halogen (iodine va- por)	55
Parking and stop rear lights Parking and direction front lights	Spherical, double filament	5/21
Rear direction indicator lights Reverse light	Spherical	21
Number plate lights	Spherical	5
Engine compartment light Interior light (in roof) Glove-box light Front ash-tray light	Cylindrical	5
Direction indicator side repeaters Open-door marker light	Tubular	4
Instruments light Fuel reserve warning light Warning light for brake system failure Headlamp main beam warning light Direction indicator warning light Parking light indicator	Tubular	3
Anti-fog warning light Emergency light indicator (Italy excluded)		1,2
Generator charge indicator		2

CONTROLS

<p>HEADLAMPS LIFTING</p> <p>Standard: electric control</p> <p>Emergency: hand operated control</p> <p>Headlamps switch</p> <p>Interior lights</p> <p>1st position: switching on and off when opening or closing doors.</p> <p>2nd position: lamp always off</p> <p>3rd position: lamp always on independently from doors.</p> <p>Luggage compartment light</p>	<p>Headlamp lifting motors and switch on light control lever.</p> <p>With hand operated knobs for headlamps lifting motors.</p> <p>Lever under the steering wheel.</p> <p>Lamp located on the rear window - three-position glass.</p> <p>Glass pushed forward.</p> <p>Glass in neutral position.</p> <p>Glass pushed backward.</p> <p>Switching on when bonnet is open and parking lights are on.</p>
---	---

HEADLAMPS

DISASSEMBLY

Headlamps can be removed in the following way:

- Lift the headlamps.
- Remove the fuses of headlamp lifting motors or the battery current wire.
- Remove the screws fixing the front panel C.
- Loosen the screws D, withdraw the headlamp then remove the bulb H (fig. 12).
- Withdraw the headlamp and the reflector assembly.
- Replace the bulb without touching the quartz bulb with fingers; should this happen, clean the bulb with alcohol.

WARNING - Do not fit lamps of different type or wattage in order to avoid any damage to the system.

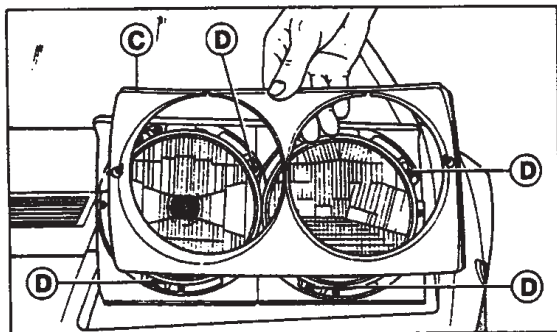

Fig. 10 - REMOVING HEADLAMP PANEL and SCREWS RETAINING LENS ASSEMBLY.
C - Headlamp panel; D - Screws retaining lens assembly.

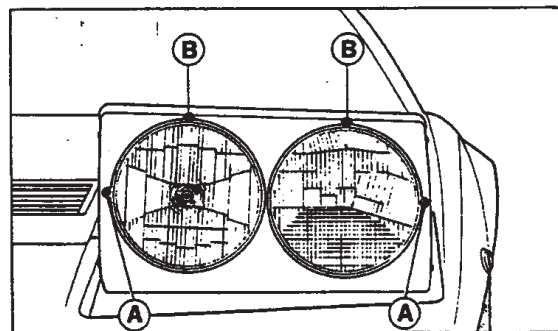

Fig. 11 - HEADLAMP ADJUSTING SCREWS.
A - Horizontal adjusting screws;
B - Vertical adjusting screws.

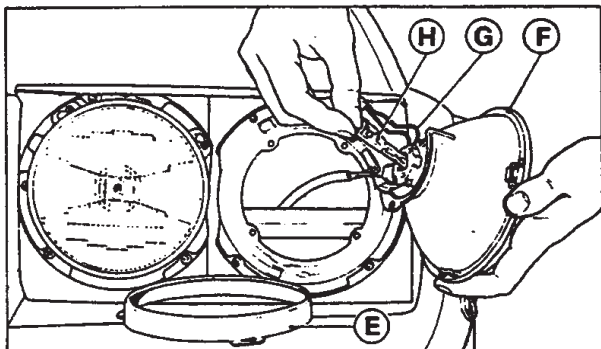

Fig. 12 - CHANGING HEADLAMP BULB.
E - Headlamp fixing ring; F - Reflector assembly; G - Bulb clamp; H - Bulb.

EMERGENCY DEVICE FOR LIFTING RETRACTABLE HEADLIGHTS

If the electric device for lifting the headlights fails, operate in this way:

- Take off the fuses protecting the headlights motors from fuses box or disconnect the battery leads in order to avoid a short circuit.
- Turn the knobs A, one after the other, counterclockwise for 2 or 3 complete turns.
- Carry out this operation until the lifting is completed.

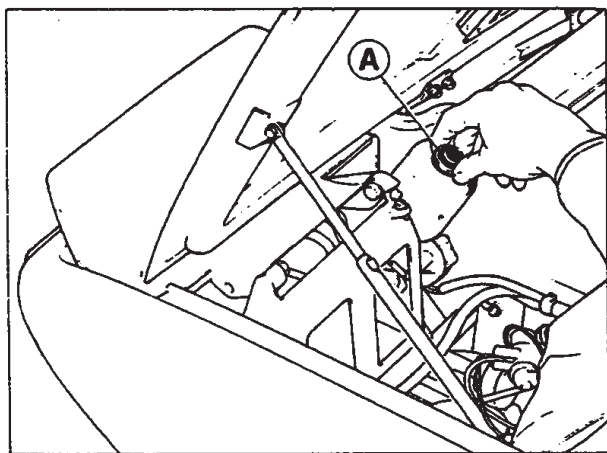

Fig. 13 - HEADLAMP LIFTING MOTOR.

HEADLAMP ALIGNMENT

The neadlamps must be aligned with the car unladen. This operation involves both anti-dazzle and driving beams since this vehicle is equipped with four headlights.

Check that tyre pressures are correct according to prescribed values. Position the car on level ground, 10 meters from an opaque vertical white screen suitable shaded and make sure that the centerline of the car is at right angles to the screen. Bounce the car to ensure correct settlement of the suspensions.

Draw on the screen (fig. 14) two pairs of vertical lines a-a and a'-a' at a distance $A' = 1236$ mm. - $A = 925$ mm. respectively, corresponding to the distance between the inner and outer headlights; these lines must be equidistant from the vertical line to the center line

of the car.

Now draw two horizontal lines $b-b$ and $b'-b'$ at a distance $B = C - 14$ cm., $B' = C - 6$ cm.: this is intended for new or overhauled cars (overhauling of suspensions) and for run-in cars. C = height of center of headlamps above ground level, measured at time of alignment.

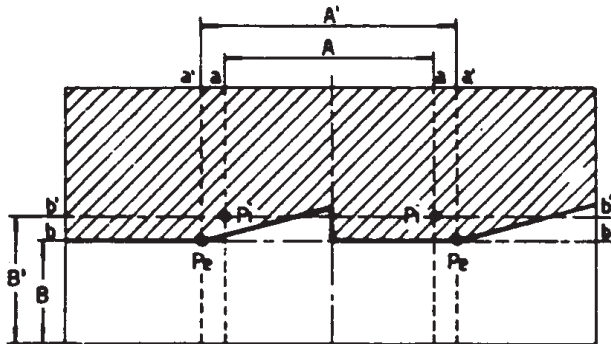

Fig. 14 - HEADLAMP ALIGNMENT DIAGRAM.

Switch on the lower beam (outer headlights) and adjust the lens assemblies with screws B for vertical alignment and screw A for horizontal alignment, so that:

- The horizontal line dividing the dark and illuminated areas is on line $b-b$.
- The lines inclined upward at about 15° start from the points of intersection Pe (or a little outside them) of the vertical lines $a'-a'$ and the horizontal line $b-b$.

To align the driving beam of inner headlights, switch on the main beams and adjust screw B for vertical alignment and screw A for horizontal alignment so that the central spot of main luminosity (luminous center) is on the intersection Pi of the horizontal line $b'-b'$ and the two lines $a-a$.

The maximum distance of A and A' may be 26 cm. over the theoretical distance corresponding to a total divergency of the beams of 3° .

WARNING - The headlamps alignment should be effected in this way:

- adjust screws of outer headlights for the anti-dazzle beam;
- adjust screws of inner headlights for the driving beam.

RADIO EQUIPMENT

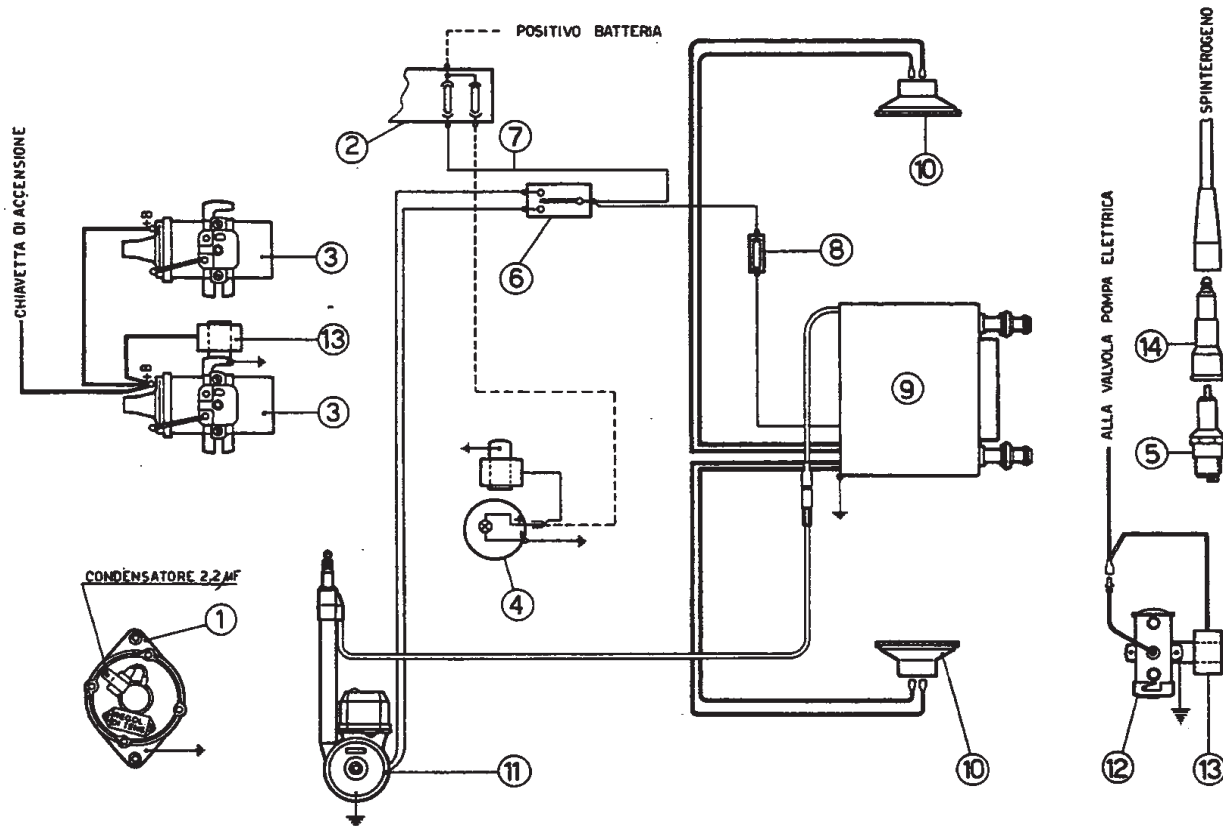

Fig. 15 - LAYOUT OF RADIO WIRING TO BE CAREFULLY FOLLOWED WHEN FITTING RADIO AND RELEVANT ACCESSORIES.

- | | |
|---|--|
| 1 - Bosch alternator with radio noise suppressor capacitor. | 8 - Fuse 5A (installed near the radio). |
| 2 - Fuses box. | 9 - Radio. |
| 3 - Ignition coils. | 10 - Loud speakers. |
| 4 - Quartz clock with radio noise suppressor capacitor. | 11 - Electric aerial (fitted in the luggage right side). |
| 5 - Sparking plugs. | 12 - Electric fuel pump. |
| 6 - Electrically operated aerial switch. | 13 - 0,5 μF noise suppressor capacitor. |
| 7 - Feed grey cable (fitted in all cars). | 14 - Radio noise suppressor for sparking plugs. |

WARNING - All vehicles are equipped with electric system already fitted for radio equipment: wires for electric connection of loud speakers, radio and electric aerial are installed. Therefore, just fit the radio in the proper housing on tunnel and make the suitable connections.

FUSES AND RELAYS

LEFT BOX

- 1 - A15: Windscreen wiper - Wind screen washer - Direction lights - Stop lights - Relays for radiator fans and windows motors.

RIGHT BOX

- 10 - A8: R.H. main beam.
 11 - A8: L.H. main beam and relevant warning light.
 12 - A8: R.H. dipped beam.
 13 - A8: L.H. dipped beam.

- | | |
|--|---|
| 2 - A8: Instruments. | 14 - A8: Parking lights - Number plate light - Parking light indicator - Instrument light |
| 3 - A8: Electric pump. | Engine compartment lights - Ash-tray light. |
| 4 - A15: Thermic rear window. | 15 - A15: Parking lights - Number plate light - Anti-fog light |
| 5 - A25: Heater fan motors - Air conditioning system. | Reverse lights. |
| 6 - A25: Vehicular hazard warning lights - Radio equipment - Interior lights - Open-doors marker lights - Glove-box light - Lamp receptacle. | 16 - A25: Horns - Cigarette lighter - Flashing light - Clock. |
| 7 - A15: Headlights motors. | 17 - A25: R.H. radiator fan. |
| 8 - A25: R.H. window motor. | 18 - A25: L.H. radiator fan. |
| 9 - A25: L.H. window motor. | |

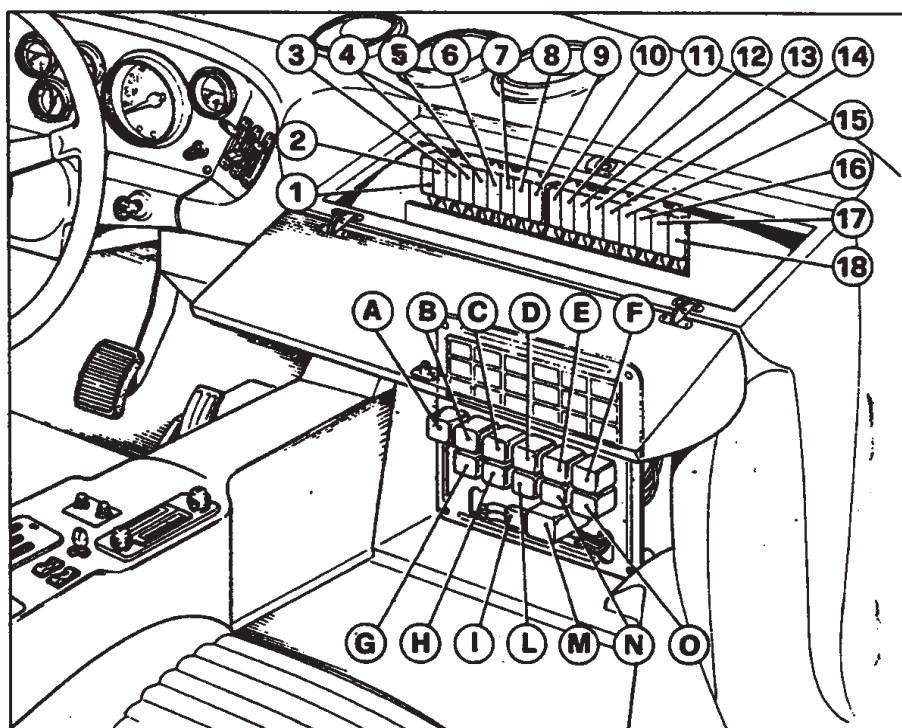

Fig. 16 - FUSES and RELAYS.

RELAYS

- | | |
|--|---|
| A - Relay for radiator left fan (BOSCH 0332014113). | H - Relay for horns (BOSCH 0332014113). |
| B - Relay for radiator right fan (BOSCH 0332014113). | I - Terminal boards protection (AMP PN 280043). |
| C - Relay for radiator right fan with operating air conditioning (BOSCH 0332014113). | L - Relay for headlamps lifting motors (BOSCH 0332204101). |
| D - Relay for parking lights (STRIBEL SR 9833). | M - Relay for emergency flashing 12V-2(4)x21W (BOSCH 0335200012). |
| E - Relay for main beam (STRIBEL SR 9833). | N - Relay for L.H. headlamp lifting motor (BOSCH 0332204101) |
| F - Relay for day or night flashing (BOSCH 0332204101). | O - Relay for R.H. headlamp lifting motor (BOSCH 0332204101) |
| G - Relay for windows motors (BOSCH 0332014113). | |

WIRING DIAGRAM

- | | |
|---|---|
| 1 - Fog lights. | 39 - Fog lights switch. |
| 2 - Headlamps main beam. | 40 - Electronic speedometer. |
| 3 - Headlamps dipped beam. | 41 - Oil pressure gauge. |
| 4 - Parking and direction indicator lights. | 42 - Oil temperature gauge. |
| 5 - Direction indicator side repeaters. | 43 - Water temperature gauge. |
| 6 - Alternator. | 44 - Electronic revs counter. |
| 7 - | 45 - Fuel level gauge. |
| 8 - Ignition distributor. | 46 - Clock. |
| 9 - Ignition coil. | 47 - Amperometer. |
| 10 - Starter motor. | 48 - Fog lights warning. |
| 11 - Horn relay (20A-12V). | 49 - Fuel reserve warning light. |
| 12 - Sending unit for water temperature gauge. | 50 - Warning light for brake system failure and hand-brake on. |
| 13 - Sending unit for oil temperature gauge. | 51 - L.H. direction indicator light. |
| 14 - Sending unit for oil pressure gauge. | 52 - R.H. direction indicator light. |
| 15 - Engine compartment lights. | 53 - Parking lights indicator. |
| 16 - Switch for engine compartment lights. | 54 - Choke ON indicator. |
| 17 - Battery. | 55 - Headlamp main beam warning light. |
| 18 - Switch for reverse light. | 56 - Glove-box light. |
| 19 - Switch for stop lights. | 57 - Glove-box light switch. |
| 20 - Fuses boxes. | 58 - Open-doors marker lights. |
| 21 - | 59 - Interior lights fitted on doors. |
| 22 - Windscreen wiper assembly. | 60 - Ash-tray with courtesy lamp. |
| 23 - L.H. heater electric fan motor. | 61 - Electric cigarette lighter. |
| 24 - Switch for heater fan motors. | 62 - Switch for handbrake warning light. |
| 25 - R.H. heater electric fan motor. | 63 - Flasher for direction indicators and vehicle hazard lights. |
| 26 - | 64 - Thermic rear window switch (Optional). |
| 27 - L.H. radiator cooling fan motor. | 65 - Warning horn switch. |
| 28 - R.H. radiator cooling fan motor. | 66 - Thermic rear window (Optional). |
| 29 - Relay switch for L.H. radiator cooling fan motor (12V - 20A). | 67 - Vehicle hazard warning light. |
| 30 - Relay switch for R.H. radiator cooling fan motor (12V - 20A). | 68 - Screen washer pump. |
| 31 - | 69 - Door jamb switch for interior lights and open-doors marker lights. |
| 32 - Rheostat and switch for instrument lights (4,5 Ω). | 70 - Interior light with incorporated switch. |
| 33 - Direction indicator switch. | 71 - Fuel level sender unit. |
| 34 - Main/dipped beam change over and flash switch. | 72 - |
| 35 - Three positions switch lever for windscreen wiper and washer pump. | 73 - |
| 36 - Parking lights switch. | 74 - Sparking plugs. |
| 37 - Ignition switch with anti-theft device. | 75 - Relay switch for L.H. headlamps lifting motor (12V - 20A). |
| 38 - Switch for vehicle hazard warning lights. | 76 - Relay switch for R.H. headlamps lifting motor (12V - 20A). |
| | 77 - Thermostatic control switch for radiator fans motor. |

- | | |
|---|--|
| 78 - Radio suppressor capacitor for alternator (2,2 μ F). | 99 - Relay switch for right radiator fan motor when air conditioner is engaged (Optional). |
| 79 - Radio suppressor capacitor (1 μ F). | 100 - Rotary knob control air conditioner fan speed (Optional). |
| 80 - Radio (Optional). | 101 - Thermostat for air conditioner (Optional). |
| 81 - Electric aerial motor (Optional). | 102 - Cooler unit fan motor (Optional). |
| 82 - Radio receiver protection fuse (5A) (Optional). | 103 - Control switch for oil pressure in brake circuits. |
| 83 - | 104 - Headlamps lifting motor. |
| 84 - Loudspeaker inside the doors (Optional). | 105 - Relay switch for headlamps lifting motors. |
| 85 - Control switch for electric aerial motor (Optional). | 106 - Microswitch on accelerator pedal for distributor retarded points (R2) control. |
| 86 - Electric fuel pump. | 107 - Rear fog light (Optional). |
| 87 - Relay for headlamps (12V - 20A). | 108 - Instrument side panel lights |
| 88 - Relay for main/dipped beams (12V - 20A). | 109 - Electric fan motors indicator. |
| 89 - Horn compressor motor. | 110 - Resistor for air conditioner fan speed control (Optional) |
| 90 - Switch for choke ON indicator. | 111 - Max. pressure switch for air conditioner (Optional). |
| 91 - Relay for day or night head lamp flashing (12V - 20A). | 112 - Min. pressure switch for air conditioner (Optional). |
| 92 - Lamp receptacle. | 113 - Cable connecting relay 91. |
| 93 - L.H. window control switch (Optional). | 114 - Cables connecting fog lights |
| 94 - L.H. window operating motor (Optional). | 115 - Stop and rear parking lights |
| 95 - R.H. window control switch (Optional). | 116 - Rear direction lights. |
| 96 - R.H. window operating motor (Optional). | 117 - Rear reflector. |
| 97 - Relay 12V-20A for windows motor control, only with the key inserted in the anti-theft device (Optional). | 118 - Number plate lamps. |
| 98 - Air conditioner compressor (Optional). | 119 - Reverse lights. |
| | 120 - Plug adaptor. |
| | 121 - |
| | 122 - Impulse generator for electronic speedometer. |

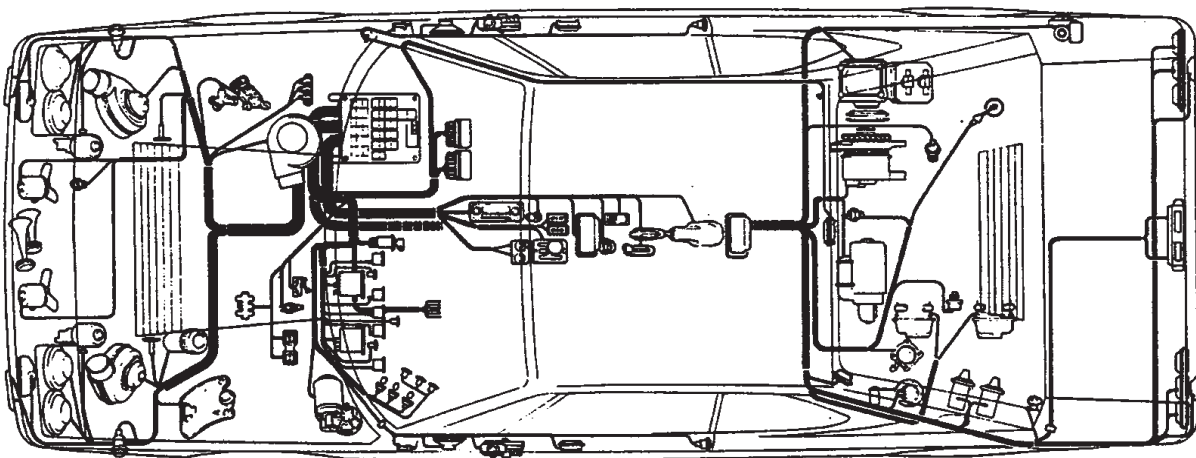

Fig. 18 - LAYOUT of ELECTRIC COMPONENTS in the VEHICLE.

COLOURS of CABLES

A - Azure	GN - Yellow striped black
B - White	HN - Grey striped black
C - Orange	VN - Green striped black
G - Yellow	AR - Azure striped red
H - Grey	HR - Grey striped red
L - Blue	AB - Azure striped white
M - Brown	RN - Red striped black
N - Black	MN - Brown striped black
R - Red	GR - Yellow striped red
S - Pink	GV - Yellow striped green
V - Green	CN - Orange striped black
Z - Violet	LN - Blue striped black
AN - Azure striped black	NZ - Black striped violet
BN - White striped black	

SECTION **M**

TOOL EQUIPMENT

TIGHTENING
TORQUES

CHASSIS
HITCH POINTS

TOOL EQUIPMENT

TIGHTENING TORQUES

CHASSIS HITCH POINTS

Page

M 3

M 5

M 8

TOOL EQUIPMENT

PART NUMBER	DESCRIPTION
	ENGINE
AV 207-CS-5730	Gauge \varnothing 81 for cylinder liners
AV 240	Lapping tool
AV 476	Wrench for damper nut
AV 498	Wrench for head tightening nuts
AV 508	Tool for valve springs
AV 617	Stand supporting engine during reassembling
AV 815	Wrench for ring nuts of timing drive pulleys
AV 819	Punch for camshafts
AV 857	Wrench for connecting rod nuts
AV 929	Seal flange for camshafts (distributor side)
AV 961-962	MOTOMETER bracket
AV 965	Pipe for freon charge
542-AS-6236	Clamp for cylinder liners
361-AS-4736	Boring bar for cylinder line
542-CS-6768	Tool with dial gauge for measuring liners protrusion from crankcase.
152-CS-7148	Tool with dial gauge for establishing pad thickness.
152-AS-7149	Plaque for dial gauge zero setting
706-AS-9560	Tool and spacer for removing pads without removing camshafts.
706-AS-9560A	
312-AS-5513	Tool for refitting valve guides
312-AS-5514	Tool for removing valve guides
L 722-AS-5897	Goniometer for engine timing checking
821-US-4720	Reamer for camshafts housings
902-CS-5969	Gauge for valve guide
	CLUTCH
AV 388	Tool for centering driven plate when fitting clutch to engine
616-AS-8478	Wrench for clutch shaft ring nut
195-AS-6271	Wrench for clutch control ring nut
	GEARBOX
175-AS-5568	Wrench for gearbox shaft ring nuts
706-AS-9561	Tool for forks lining up

PART NUMBER	DESCRIPTION
195-AS-6271	<p style="text-align: center;">GEARBOX</p> Wrench for ring nut fixing rocker arm pin
175-AS-5067 706-AS-6704 365-AS-5764 365-AS-5839 616-AS-8729	<p style="text-align: center;">DIFFERENTIAL</p> Preloading pulley Pulley extension Punch for inserting bearings Punch for inserting oil rings Punch for inserting outside bearing race
AV 485 706-AS-9016 506-AS-7394 506-AS-7783	<p style="text-align: center;">SUNDRY TOOLS FOR CHASSIS</p> Wrench for steering wheel ring nut Extractor for steering wheel Extractor for suspension and steering joints Wrench for ring nut fixing flange on hubs

TIGHTENING TORQUES

PART	THREAD	TIGHTENING TORQUES Kgm
ENGINE		
Nut, cylinder head hold-down	10 x 1	10
Nut, main bearing cap	12 x 1,25	9
Nut, con.rod bolts	10 x 1	6,6
Nut, camshaft cap	6 x 1	0,9
Bolt, flywheel to crankshaft	10 x 1,25	8,5
Sparking plugs	14 x 1,25	2
Nut, pulleys to camshafts	18 x 1,5	11
Screw fixing damper to crankshaft	18 x 1,5	20
Timing belts driving pulley	17 x 1	13
Nut fixing starter motor to engine	8 x 1,25	2,7
Nut fixing distributor to camshaft	12 x 1,25	11
Nut for water pump shaft	12 x 1,25	6
Nut fixing alternator bracket to engine	10 x 1,25	6
Nut fixing alternator to bracket	10 x 1,25	6
Nut fixing alternator to support	12 x 1,25	8
Nut fixing water pump rotor	8 x 1	2,5
Nut for timing belt stretcher	12 x 1,25	6,6
Nut for AC compressor belt stretcher	12 x 1,25	6,6
Screw, water pump cover and belt stretcher support	8 x 1,25	2,5
Screw fixing alternator pulley	14 x 1,5	4
AC compressor to supports	10 x 1,25	2
ACCELERATOR		
Pedal and levers	8 x 1,25	3

PART	THREAD	TIGHTENING TORQUES kgm
CLUTCH		
Ring nut, clutch shaft	30 x 1,5	20
Fixing the clutch housing	10 x 1,25	5,5
Nut for clutch bell and cover	8 x 1,25	2,5
Clutch control lever and help spring rest	15 x 1	9
Fixing the clutch control lever	8 x 1,25	2,5
Fixing flange to clutch housing	8 x 1,25	2,5
Fixing clutch pressure plate	8 x 1,25	3,5
GEARBOX AND DIFFERENTIAL		
Fixing supports to gearbox	10 x 1,25	7
Fixing rubber pads to supports	8 x 1,25	2,5
Fixing ring nuts for mainshaft and lay-shaft	32 x 1,5	20
Fixing front and rear gearbox covers	8 x 1,25	2,5
Ring nut for mainshaft idler gear	25 x 1,5	18
Gearshift forks	8 x 1,25	2,5
Ring nut for rocker arms pins	15 x 1	11
Fixing differential cover	8 x 1,25	2,5
Fixing crown to differential	10 x 1	10,4
Fixing flanges to differential	12 x 1,5	9
Fixing flange to differential housing	8 x 1,25	2,5
Fixing axle-shafts to differential flanges	10 x 1,25	8
FRONT SUSPENSION		
Fixing shock absorbers	12 x 1,25	7
Fixing ball joints to steering knuckle	12 x 1,5	6,4
Stabilizer bar to link	12 x 1,25	7
Fixing stabilizer bar links to levers	12 x 1,25	7
Suspension levers to forks	12 x 1,25	7
Suspension forks to chassis	14 x 1,5	8

CHASSIS HITCH POINTS

PART	THREAD	TIGHTENING TORQUES kgm
FRONT SUSPENSION		
Fixing steering levers on steering knuckle	20 x 1,5	16
Brake calipers to steering knuckle	12 x 1,25	10
Fixing ball joints to levers on knuckle	3/8"x24 UNF	4,5
Brake discs to wheel hubs	8 x 1,25	2,5
REAR SUSPENSION		
Brake discs to hubs	8 x 1,25	2,5
Axle-shaft flange to wheel shaft	27 x 1,25	22
Fixing wheel to hub	14 x 1,5	9
Brake calipers to hub carrier	12 x 1,25	10
Fixing shock absorbers - cadmium plated	12 x 1,5	5,6
- bonderized	12 x 1,5	7
Suspension levers to forks	12 x 1,25	7
Lever forks to chassis	14 x 1,5	8
Suspension levers to hub carrier	12 x 1,5	7
Axle-shafts to flange	10 x 1,25	8
Fixing rear hub bearing	8 x 1,25	2,1
Fixing rod to link - Up to car no.08660	12 x 1,25	7
- From car no. 08662	8 x 1,25	2,1
BRAKES		
Ring nut for pin of brake booster lever	16 x 1,5	10
STEERING		
Fixing ball joints to steering box arms	12x20 UNF	7
Fixing steering lever to knuckle	20 x 1,5	16
Fixing steering box support to chassis	8 x 1,25	3
Fixing steering wheel hub to column	22 x 1,5	14

SECTION **N**

BODY

	Page
GENERAL INFORMATION	N 3
DOORS	N 4
GLASSES	N 4
BONNETS	N 6
FRONT AND REAR BUMPERS	N 6
INSTRUMENTS PÄNEL	N 6
SEATS	N 7
CHASSIS	N 7
MAINTENANCE	N 7

B O D Y

GENERAL INFORMATION	Page N	3
DOORS	" N	4
REMOVING ONE DOOR	" N	4
REASSEMBLING ONE DOOR	" N	4
ADJUSTMENTS	" N	4
GLASSES	" N	4
REMOVING AND REASSEMBLING THE SLIDING WINDOW	" N	4
REMOVING AND REASSEMBLING THE DOOR FIXED WINDOW	" N	5
REMOVING AND REASSEMBLING THE WINDSCREEN	" N	5
REMOVING AND REASSEMBLING THE REAR WINDOW	" N	5
REMOVING AND REASSEMBLING THE REAR SIDE WINDOWS	" N	6
BONNETS	" N	6
HOOD AND ENGINE BONNET	" N	6
REAR AND FRONT BUMPERS	" N	6
REMOVING AND REASSEMBLING	" N	6
INSTRUMENTS PANEL	" N	6
REMOVING AND REASSEMBLING	" N	6
SEATS	" N	7
REMOVING AND REASSEMBLING	" N	7
CHASSIS	" N	7
BODY MAINTENANCE	" N	7
CLEANING UPHOLSTERY	" N	7
CLEANING SIMILAR LEATHER	" N	7
CLEANING LEATHER	" N	8
CHROMIUM-PLATED PARTS	" N	8
PROCEDURES FOR RETOUCHINGS AND PAINTING	" N	8
NON METALIZED PAINTS	" N	8
METALIZED PAINTS	" N	9
CAR WASHING	" N	11

GENERAL INFORMATION

Dino 308 GT4 - F 106 AL - Load bearing chassis, two doors and two side windows.

- Hood with front hinges; the release is controlled from the interior by a lever placed under the dashboard on driver's side.
- Front window with safety stratified glass. Anodized aluminium rim (in two pieces) fixed with clips, bead sealing Window Weeld Ø 8-3 M - MINESOTA and silicone sealing 854804 IVI INVES.
- Doors with front fixing hinges; windows with two safety glasses. The front glass is fixed while the rear one is controlled by hand or by electric motor. Outside lock by key.

- Door outside handles: chromium-plated and black painted with lever control.
- Rear flat window; brass black painted rim with addition of silicone sealing 854804 IVI INVES.
- Rear luggage compartment - lid provided with two locks; the release is obtained by a lever placed on the rear door pillar on driver side.
- Rear number plate - fitted to the centre of the car below the luggage compartment lid. Front and rear steel bumpers with black rubber outside gasket. Parking and direction lights are placed in the front bumper while the reverse lights are placed in the rear bumper.
- The lid for fuel filler is on the left rear side.
- Front adjustable seats with reclinable squabs, adjustable headrests. Rear seats are fixed with headrests fitted to the wall between interior and engine compartment.
- Instrument panel in ABS resin and similar leather padding and covering. Instruments are placed on the driver's side with central controls and three adjustable air outlets. The central air outlet operates only when air conditioner is on. On the passenger's side there is the glove-box with safety lock and interior removable courtesy mirror.
- Sun visors are padded and adjustable. Map pockets are fitted to door inside panel and a third rear central pocket. Moquette on the front and rear floor. Carpet in luggage compartment. Interior upholstery in similar leather, leather or deerskin for seat central area and headrests.

DOORS

REMOVING ONE DOOR

The door removing is effected as follows:

- With the door completely open, withdraw the lock ring.
- Using a hammer, remove the hinge pin.
- Remove the door from mountings.

REASSEMBLING

Repeat the aforementioned instructions duly reversed.

ADJUSTMENTS

In case that the door is not correctly settled in its frame, adjust it. Here the relevant instructions:

- Loosen the screws fixing the lock latch and move it by hammering until an acceptable setting is obtained. The door should close and open perfectly; the lock should operate efficiently; the door safety lock should lower under a slight pressure. A further adjustment can be effected with the window regulator control cable by means of a cam located in the cable lower end.

GLASSES

REMOVING AND REASSEMBLING THE DOOR WINDOW

- Remove the window control handle, the door inside handle and the safety lock.
- After unscrewing the fixing screws, remove the panel.
- Unscrew the relevant screws and move the front fixed glass.

- Remove the window support after unscrewing the relevant screws.
- Remove the glass with care turning it towards the front side of the car.

In order to reassemble the glass, carry out the aforementioned operations duly reversing them.

REMOVING AND REASSEMBLING THE DOOR FIXED WINDOW

After removing the panel, take off the fixing bracket using a drilling machine then push up and down and slightly forward the glass. To refit the window, place the glass in the proper frame pushing it upwards; settle the fixing bracket and rivet it to the door frame.

REMOVING AND REASSEMBLING THE WINDSCREEN

The windscreen is removed as follows:

- Remove the windscreen wipers.
- Protect the dashboard and remove the glass inside sheathing.
- Remove the upper and lower rims with care.
- Using a blade, cut the sealing all around the glass, from the interior.
- Press the upper corners of the windscreen with both hands thus causing the removing of the screen from its frame.

When refitting the windscreen, follow the instructions below:

- Carefully clean the windscreen with heptane removing the remaining sealing.
- End the cleaning operation by using PRIMER 854803 for silicone sealing (supplied with sealing 854804 IVI INVES): pay attention not to damage the paint.
- If necessary, replace the rim fixing clips.
- Place the Window Weeld bead all around the windscreen then pull it slightly in order to reduce its diameter.
- Clean the windscreen glass and place it carefully in its frame.
- Set the rim in the proper seat after covering it with masking tape.
- Cover with masking tape the outer surface of glass seat and all around the glass.
- Put silicone sealing 854804 IVI INVES in the two spaces between the three surfaces covered with masking tape.
- Definitely insert the rims pressing them and spreading the silicone sealing in a way that a smooth surface is obtained.
- Take off the masking tape and let dry for 24 hours.

REMOVING AND REASSEMBLING THE REAR WINDOW

Remove the rear window following the instructions below:

- Remove the rear seat and headrests plus the rear window sheathing.
- From the interior, cut with a blade the sealing which is around the window. In case of a thermic window, pay attention to the electric wires located in the passenger upper area.
- From the interior, press the window upper part with both hands removing in this way the glass from its frame.

Reassemble the window in the following way:

- Carefully clean the rear window from the remaining sealing.
- End cleaning operation using PRIMER 854803 for silicone sealing (supplied with 854804 IVI INVES product): pay attention not to damage the paint.
- From the outside, cover with masking tape the window.
- Correctly set the glass in its frame, helping with spacers if necessary.
- From the outside, cut the masking tape following the perimeter inner outline of the window frame.

- Remove the glass from its frame, take off the masking tape (previously cut from glass) then degrease with PRIMER 854803.
- From the interior, apply silicone sealing 854804 IVI INVES all around the window frame.
- Refit the glass helping, as already mentioned, with spacers.
- Remove, from the outside, the exceeding sealing and spread it on the inside area in a way that a smooth and homogeneous surface is obtained.
- Let dry for 24 hours, then take off the masking tape from the glass. Refit window sheathing and seats.

REMOVING AND ASSEMBLING THE SIDE REAR WINDOWS

- Remove the side sheathing after withdrawing the relevant screws.
- Take off the rivets fixing the glass frame after drilling them; then withdraw the glass pulling it forward.
- After removing the frame, unscrew the two screws fitted to the front corners, then withdraw the glass and the rubber gasket.

The rear side glasses can be reassembled following the aforementioned instructions duly reversed.

BONNETS

HOOD AND ENGINE BONNET

The hood and the engine bonnet are articulated by front and inner hinges; the lock is operated by proper pins.

Bonnets are held in open position by proper stays.

Should the bonnets be replaced, remove the screw locking the stay (only the upper screw) then take off the hinge screws.

After reassembling, the bonnet should be perfectly settled in the proper seat, it should open and close easily without any effort. To adjust the bonnet in the proper seat, operate on the hinges and on the lock.

The levers opening the engine and luggage compartment lids are located on the driver side door pillar.

FRONT AND REAR BUMPERS

To remove both bumpers, act as follows:

- Disconnect the headlamps wires.
- Remove the screws fixed on bumper brackets.
- The rubber protection can be removed only after unscrewing the proper bolts fixed inside the bumpers.

When reassembling, carefully check that bumpers are correctly lined up then fix them.

INSTRUMENT PANEL

REMOVING AND REASSEMBLING

- Remove the steering wheel, the column and the mainswitch.
- Remove the sheathing under the steering wheel and that of the wind screen.
- Remove the instrument panels unscrewing the 6 fixing bolts.
- Withdraw the instrument blocks.

- Remove the side panels inside the glove-box compartment to reach the fixing central and lateral points of the instrument panel; the third fixing point (driver side) can be reached after the instrument panel has been removed.
- Unscrew the 6 panel fixing points then pull everything towards the car interior.

Reassemble the instrument panel following the above operations duly reversed.

SEATS

REMOVING AND REASSEMBLING

Remove the front seats:

- Push the seat backward and take off the two front screws fixing the guides.
- Move the seat forward and take off the two rear screws.
- Remove the seat.

Disassemble the rear seat in the following way:

- Withdraw the screws from the lateral and central pockets.
- Pull and remove the seat.

To obtain the dismantling of the headrests, remove the 4 nuts from the engine compartment.

Reassemble the seats and headrests performing, duly reversed, the above operations.

CHASSIS

Always apply to a Ferrari Authorized Service for any operation regarding the chassis.

BODY MAINTENANCE (CLEANING THE UPHOLSTERY)

To ensure long life and clean condition of the upholstery, periodically clean it with special care.

Dust and particles deposited on the upholstery while the car is in use must be removed at regular intervals (every fortnight) and more often if the car is being used extensively during these intervals.

A brush or vacuum cleaner may be used for this.

A neutral soap dissolved in lukewarm water is best for general upholstery; this may be applied with a rag or brush, care being taken to rub the upholstery in the direction of the grain and not against it. Then, the soap should be removed with a clean rag and when the upholstery has been rubbed dry, it should be brushed against the grain to restore its original appearance.

To remove stains, these should be dealt with as soon as possible after their appearance as, if they are left for a long time, they will oxidize and removal will be more difficult or even impossible. Some kind of stains require the use of special removers.

CLEANING SIMILAR LEATHER

Never use oil, varnish or ammoniacal solutions.

Changes or loss of elasticity and gloss in artificial leather are often due to the use of unsuitable and damaging cleaners.

To keep similar leather in good condition, it should be washed with a wet rag smeared with a little ordinary soft soap. After this, polish the artificial leather with a damp rag to remove all traces of soap. Finally rub the material with a clean dry cloth to restore its original appearance.

CLEANING LEATHER UPHOLSTERY

Remove the dust using vacuum cleaner, compressed dry air or dry and clean cloth.

To remove possible stains use a sponge with mild soap and water, rinse and dry immediately using chamois leather.

CHROMIUM PLATED PARTS

Chromium plated parts should be washed periodically with a rag dipped in kerosene, then dried and rubbed with a rag moistened with thin oil. Then rub with a clean woollen cloth to remove all traces of oil.

PROCEDURES FOR TOUCH-UP AND PAINTING

For painting the Dino 308GT.4, FERRARI uses thermosetting acrylic paint (ACRILUR) for pastel colours and thermoplastic acrylic paint (EUROLAC) for metalized colours.

NON METALIZED PAINT

A - PROCEDURE FOR SPRAYING SMALL AREAS WHICH DO NOT NEED SURFACING

- 1 - Sand carefully with rubbing paper No. 600 the area to be resprayed.
- 2 - Apply 4 or 5 light layers of thermosetting ACRILUR enamel on the sanded area: allow some minutes between each application. Before use, the enamel should be thinned to 20% with 6-C-310 thinner and catalyzed to 3% (after thinning) with 19-T4 catalyst. Viscosity should be 17" Ford 4 at 20°C.
- 3 - Let dry by infrared ray lamps for 30 minutes at a temperature of 80-90°C since the catalyst does not operate at lower temperatures.
- 4 - Sand carefully the surfaced area with rubbing paper No. 1200.
- 5 - To end, buff and polish.

B - PROCEDURE FOR SPRAYING AREAS WHICH REQUIRE SURFACING

- 1 - Sand the involved area until the metal sheet is carefully cleaned; then clean again with white cloth wetted with alcohol.
- 2 - Apply epoxy 28-G-29 filler catalyzed to 100% with 27-E-29 catalyst.
- 3 - Let dry by infrared ray lamps for 30 minutes at a temperature of 80-90°C.
- 4 - Sand with rubbing paper No. 280.
- 5 - Apply 4 or 5 layers of epoxy 28-Y-44 primer catalyzed with 27-T-40 catalyst to 20% and thinned with 6-C-25. Viscosity: 25-30" Ford 4 at 20°C.
- 6 - Let dry the epoxy primer by infrared ray lamps for 30 minutes at 80-90°C.
- 7 - Sand with rubbing paper No. 400 or 500.
- 8 - Clean with white cloth and alcohol.
- 9 - Apply 4 or 5 light layers of thermosetting ACRILUR enamel on the

sanded area allowing some minutes between each application. Before use, thin the enamel with 6-C-310 thinner (to 20%) then catalyze with 19-T-4 catalyst (to 3% after thinning).

- 10- Let dry by infrared ray lamps for 30 minutes at 80-90°C since the catalyst will not operate at lower temperatures.
- 11- Carefully sand the touched-up surface with rubbing paper No.1200.
- 12- Buff and polish.

C - PROCEDURE FOR RE-SPRAYING LARGE AREAS

This procedure is explained in our technical information regarding painting with EUROLAC thermoplastic products. This kind of work can be effected, in fact, easily and without risks when using products which require minimum and less precise drying process. We wish to point out that the thermosetting enamels can be painted with any kind of touch-up products while the thermoplastic enamels, instead, require only thermoplastic acrylic products for repainting.

- 1 - Sand the area to be repainted until the metal sheet is carefully cleaned then clean again with cloth and alcohol.
- 2 - Apply the filler which should be a two-component epoxy type then allow it to dry following the Supplier's instructions.
- 3 - Sand the involved area with rubbing paper No. 220 until a regular surface is obtained. Extend this operation to all interested surfaces and completely remove the original finishing paint.
- 4 - Apply the primer which should be a two-component epoxy type then let dry following the Supplier's instructions.
- 5 - Carry out a wet sanding using rubbing paper 320 then wash carefully the sanded area with distilled water and after this with heptane.
- 6 - Apply 2 or 3 light coats of undercoat EUROLAC, basic colour, allowing some minutes between each application and blow air during these intervals.
The enamel should be mixed in the proportion of 1 to 1 by weight with acrylic thinner GLIDDEN-SALCHI 6-C-132. If this is not available, the DU PONT thinner 360-2S may be used.
- 7 - After the last coat, allow the finish to air-dry for 60 minutes, or, alternatively, 10 minutes after painting heat the painted area with infrared ray lamps for 40-45 minutes at 70-80°C.
- 8 - Sand the touched-up surface carefully with rubbing paper 1000.
- 9 - To end, buff and polish.

If suitable equipments are available, use thermosetting and catalyst products, as explained under point B, for respraying large areas too.

METALIZED PAINT

D - PROCEDURE FOR SPRAYING AREAS WHICH DO NOT NEED APPLICATION OF BODY FILLER.

- 1 - Sand carefully the area to be resprayed with rubbing paper 600.
- 2 - Apply 4 or 5 light layers of EUROLAC acrylic enamel allowing some minutes between each application and blowing air during these intervals. The enamel should be mixed, in the proportion of 1 to 1,3 by weight, with acrylic thinner GLIDDEN-SALCHI 6-C-132. If this thinner is not available, DU PONT thinner 360-2S may be used.

It is very important that the metalized paint is carefully stirred before thinning, before injecting it into the cup of the spray gun and before each application: this will avoid that the metallic particles leave a deposit on the bottom thus altering the paint shade.

- 3 - Allow the finish to air dry for 60 minutes or, alternatively,

ten minutes after spraying, heat the painted area by infrared ray lamps for 40-45 minutes at 70-80°C.

- 4 - Wet sand the painted area with rubbing paper 600. Carefully wash with distilled water and then with heptane.
- 5 - Apply 4 or 5 light layers of enamel mixed in the proportion of 1 to 1,3 / 1,4 by weight, following the procedure as per point D 2.
Apply, as final, 2 or 3 coats of transparent EUROLAC acrylic 20-T-7 enamel mixed in the proportion of 1 to 1,2 with 6-C-132 thinner or, if not available, with DU PONT thinner 3602 S.
- 6 - Repeat the finish drying as per point D 3.
- 7 - Sand the area with rubbing paper 1000.
- 8 - As final operation, buff and polish.

E - PROCEDURE FOR SPRAYING AREAS WHICH NEED APPLICATION OF BODY FILLER.

- 1 - Sand the area to be resprayed until the metal sheet is carefully cleaned then clean again with cloth and heptane or Avio gasoline.
- 2 - Apply the filler which should be a two-component epoxy type and let dry following the Supplier's instructions.
- 3 - Carry out a wet sanding using rubbing paper 220 then wash carefully the area involved with distilled water and then with heptane.
- 4 - Apply 4 or 5 light layers of EUROLAC acrylic enamel allowing some minutes between each application and blowing air during these intervals.

Before use, mix the enamel in the proportion of 1 to 1,3 by weight with acrylic thinner GLIDDEN-SALCHI 6-C-132 or, if not available, the DU PONT thinner 3602 S may be used.

It is very important that the metalized paint is carefully stirred before thinning, before injecting it into the cup of spray gun and before each application: this will avoid that the metallic particles leave a deposit on the bottom thus altering the paint shade.

- 5 - Allow the finish to air dry for 60 minutes or, alternatively, ten minutes after spraying, heat the painted area by infrared ray lamps for 40-45 minutes at 70-80°C.
- 6 - Carry out a wet sanding using rubbing paper 600 then wash with care the area involved with distilled water and after this with heptane.
- 7 - Apply 4 or 5 light layers of enamel thinned in the proportion of 1/3-1,4 by weight following the instructions of point E 4.
Apply, as final, 2 or 3 coats of transparent EUROLAC acrylic 20-T-7 enamel mixed in the proportion of 1 to 1,2 with 6-C-132 thinner or, if not available, with DU PONT thinner 3602 S.
- 8 - Repeat the finish drying operation as per point E 5.
- 9 - Sand the area with rubbing paper 1000.
- 10 - As final operation, buff and polish.

F - PROCEDURE FOR SPRAYING LARGE AREA IN METALIZED PAINT

- 1 - Sand the area to be repainted until the metal sheet is carefully cleaned. After this, clean again with cloth and heptane or Avio gasoline.
- 2 - Apply the filler which should be a two-component epoxy type and let it dry following the Supplier's instructions.
- 3 - Sand the involved area with rubbing paper 220 until a regular surface is obtained. Extend this operation to completely remove the original finishing paint.
- 4 - Apply the primer which should be a two-component epoxy type then let it dry following the Supplier's instructions.

- 5 - Carry out a wet sanding using rubbing paper 320; wash the sanded area with care using distilled water and then heptane.
- 6 - Apply 4 or 5 light layers of EUROLAC acrylic enamel allowing some minutes between each application and blowing air during these intervals. The enamel, before use, should be mixed, in the proportion of 1 to 1,3 by weight, with acrylic thinner GLIDDEN - SALCHI 6-C-132. If this is not available, use DU PONT thinner 3602 S.
It is very important that the metalized paint is carefully stirred before thinning, before injecting it into the cup of the spray gun and before each application: this will avoid that the metallic particles leave a deposit on the bottom thus altering the paint shade.
- 7 - Allow to air dry for 60 minutes or, alternatively, ten minutes after spraying, heat the painted area by infrared ray lamps for 40-45 minutes at 70-80°C.
- 8 - Carry out a wet sanding on the painted area with rubbing paper 600. Carefully wash with distilled water and then with heptane.
- 9 - Apply 4 or 5 light layers of enamel mixed in the proportion of 1/3-1,4 by weight, following the procedure as per point E 4. Apply, as final, 2 or 3 coats of transparent EUROLAC acrylic 20-T-7 enamel mixed in the proportion of 1/1,2 with 6-C-132 thinner or, if not available, with DU PONT thinner 3602 S.
- 10- Repeat the drying operation as per point F 7.
- 11- Sand the interested area with rubbing paper 1000.
- 12- As final operation, buff and polish.

CAR WASHING

The body should be washed at varying intervals, according to the extent to which the car is used and, of course, to the state of the roads over which it has run.

Begin with washing the outside of the body avoiding too powerful a jet. Finish off with a sponge used lightly, to prevent scratching the paint with any remaining particles of mud or dust, and then with more pressure but always with plenty of water. Wash the sponge frequently. Then dry the whole car thoroughly with a clean chamois leather, removing every trace of moisture.

If the enamel does not regain its original gloss after this operation, it may be treated with one of the various preparations on the market. If the material used to apply the preparation should show marks of the same colour as the paint, this will have no effect on the gloss and durability of the latter.

Stains of grease, oil and tar on the paintwork can be removed with a little gasoline followed by rubbing with a dry cloth.

SECTION

O

EMISSION
CONTROL
SYSTEM

	Page
ENGINE	O 2
CARBURETTOR SETTING DATA	O 2
CARBURETTOR SERVICE	O 2
FAST IDLE DEVICE	O 4
SPARKING PLUGS	O 5
IGNITION DISTRIBUTORS	O 6
ADJUSTMENT OF MICROSWITCH	O 8
EXHAUST EMISSION CONTROL SYSTEM	O 9
MAIN SPECIFICATIONS	O 9
AIR INJECTION SYSTEM	O 9
AIR PUMPS	O 10
AIR PUMPS BELTS	O 11
DIVERTER VALVES	O 13
EVAPORATIVE EMISSION CONTROL SYSTEM	O 14
THREE-WAY VALVE	O 15
ACTIVATED CARBON TRAP	O 16
LIQUID VAPOR SEPARATOR	O 16
ELECTRICAL SYSTEM	O 17
BULBS	O 18
FUSES AND RELAYS	O 18
WIRING DIAGRAM	O 20

ENGINE

CARBURETTOR SETTING DATA

DESCRIPTION		WEBER 40 DCNF 35/36/37/38
Choke	mm.	32
Central diffusor	mm.	4,5 L
Main jet	mm.	1,35
Air correction jet	mm.	2,20
Emulsion tube		F 24
Slow running jet	mm.	0,55
Slow running air correction jet	mm.	1,70
Pump jet	mm.	0,45
Pump discharge	mm.	0,40
Needle valve	mm.	1,75
Pump delivery valve	mm.	0,50
Choke jet		60 F 6
Progression orifices	mm.	0,80 - 1,40 - 1,30 - 1,60 - 0,80
Protrusion of float without gasket	mm.	50

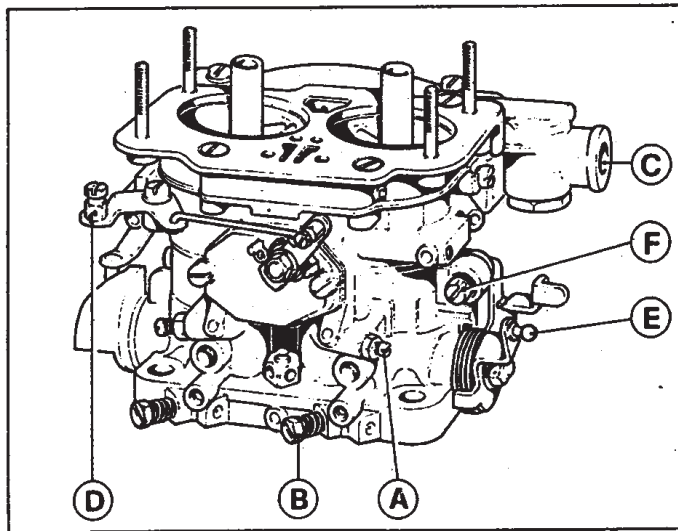

Fig. 1 - CARBURETTOR.

A - By-pass screw for depression balancing in the carburettor venturi; B - Idle speed mixture adjusting screw; C - Fuel inlet; D - Choke control lever; E - Throttle valve lever; F - Throttle opening adjusting screw.

CARBURETTORS SERVICE

The carburettors service must be carried out together with fuel and air cleaner filter service, idle speed and mixture inspection, fast idle device setting.

PROCEDURE

Warning : Make sure that the air conditioning is not connected.

- a - Inspect fuel and air cleaner filter and replace if necessary.
- b - Clean carburettor float chambers, jets, filters. Check the fuel level in carburettors. Check the linkage for excessive play or binding.

- c - Unscrew bolts of pipes fitted on every exhaust manifold corresponding to each cylinder and screw on the rear exhaust manifold the extension pipes for CO/HC analysis that are in the tool-kit. Screw in every extension pipe a short line for CO probes (see fig. 3).
- d - Connect a tachometer to the advanced breaker point R1 of one distributor; prepare and calibrate instrument for CO/HC analysis.
- e - Remove air intake and after having warmed up the engine until the fast idle disconnects (engine water temperature 82°C), with the idling at the speed of 1000 RPM, check the ignition timing and adjust if necessary. Then check the synchronization of the carburettors throttles by means of the motometer synchronizer. If necessary adjust them acting on the throttle opening screws, balance depression screws and idle mixture screws.
- f - Connect the analyzer probe to every extension pipe mounted on the exhaust manifolds relating to each cylinder and make sure that CO and HC percentages coming out from the cylinder are within the limits prescribed by the air-pollution label: CO = $2\% \pm 1,5\%$ - HC = 300 p.p.m. and, if necessary, adjust mixture by turning the idle mixture adjusting screw located at the bottom of each barrel of each carburettor: turn clockwise to decrease CO%, turn anticlockwise to increase it.
- g - Insert the probe alternatively inside both exhaust silencer tails and make sure that CO and HC are below the limits prescribed by the air-pollution label: CO = max. 1,5% - HC = max. 300 p.p.m.
- h - If the emission values in both the cases described in (f) and (g) are not within the limits prescribed by the metal label carry out the subsequent checkings:
 - 1) Make sure that the spark plugs wires do not discharge outside.
 - 2) Check spark plugs (cleaning, gap and check the spark plugs with the test-bench if there are irregular discharges).
 - 3) Check ignition timing, dwell and distributor breaker points.
 - 4) Check again cleaning of carburettors, filters and slow running jets.
 - 5) Check air pump pressure by a manometer (5 m. \pm 1 m. H₂O at 5000 RPM in neutral) and the free air passage through the valves of the air injection system.

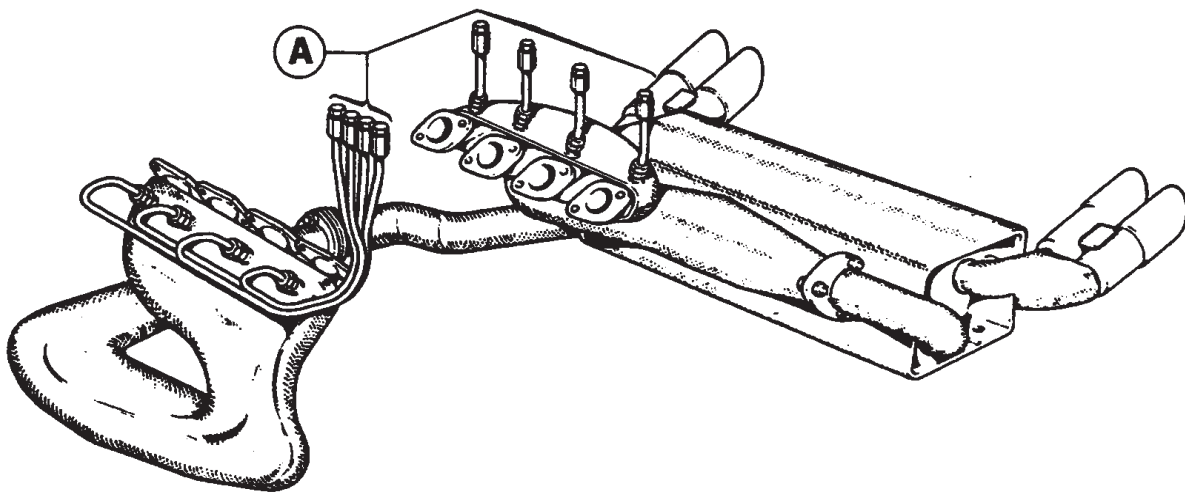

Fig. 2 - EXHAUST SYSTEM WITH GAS ANALYSIS PROBES.
A - Gas analysis pipes.

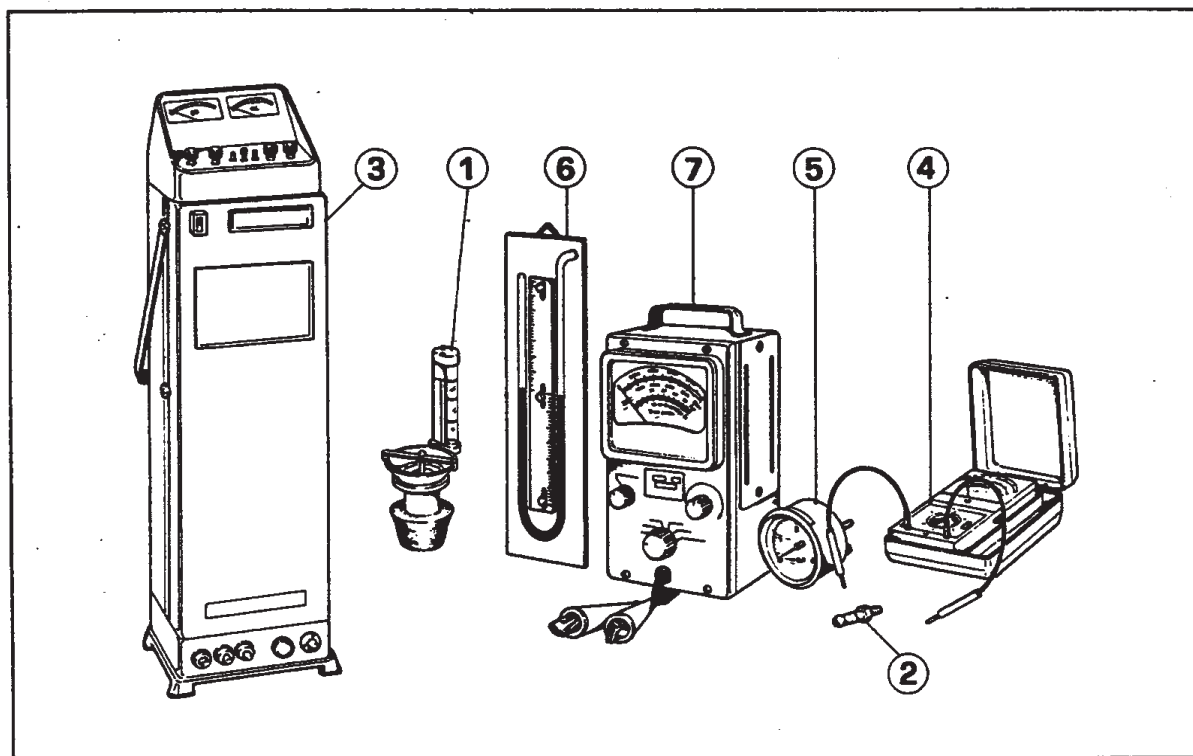

Fig. 3 - SPECIAL TOOLS.

1 - Motometer carburettor throttle synchronizer; 2 - Extension short lines for CO probes fitted on the exhaust pipes; 3 - CO/HC tester (HORIBA MEXA 300 type) with probe and filter; 4 - Electric tester; 5 - Manometer for measuring air pump pressure (in H₂O m.); 6 - Manometer for checking three-way valve of the evaporative emission control system (mm.H₂O); 7 - Tachometer with dwell angle measuring instrument.

FAST IDLE DEVICE

In the manifold, through which the cooling water comes out from the two cylinder rows of the engine, there is a case containing a thermostatic spiral which can lengthen in the direction of rotation according to the engine water temperature.

When the thermostatic spiral rotates, also a cam connected to the spiral rotates.

On the cam lies the extremity of a rocker arm which, on the other extremity, has an adjusting screw acting on a lever connected with the carburettors throttles.

With cold engine (water temperature under 49° C) the cam position is such that, through the rocker arm, the carburettor throttles are slightly open thus causing the fast idle. (Position 20 marked on the cam).

According to the increase of engine water temperature, the cam rotates gradually toward the minimum lift so that the engine can run at idle when the water temperature is 82° C ± 4,5° C.

Maximum fast idle speed: 3100 ± 300 RPM when the engine is cold.

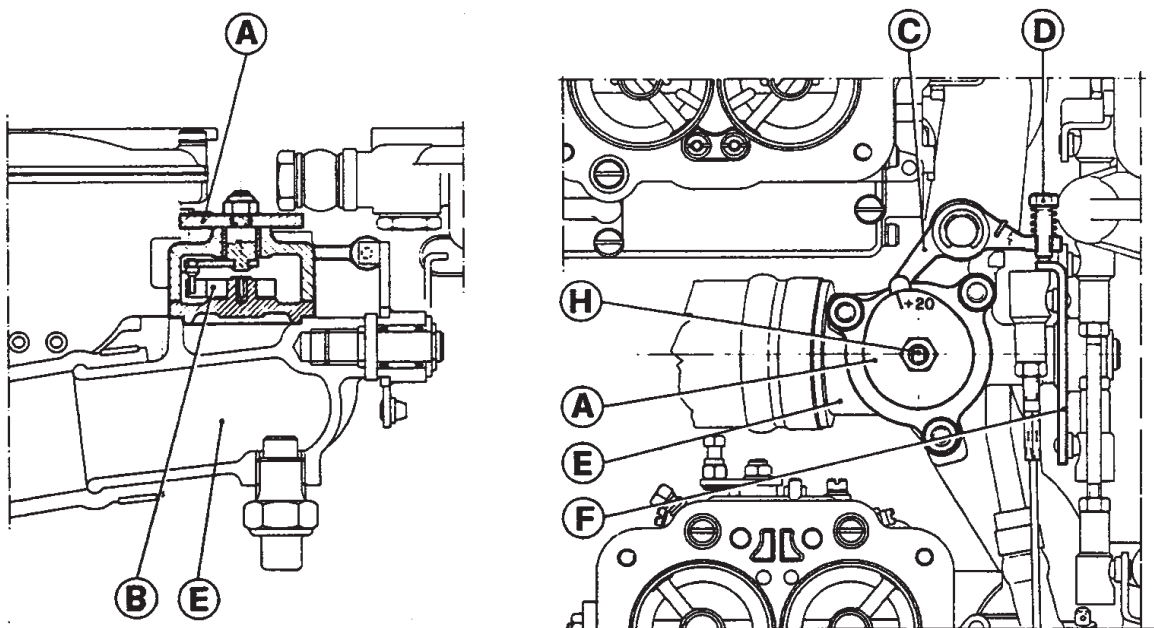

Fig. 4 - FAST IDLE DEVICE.

A - Cam; B - Thermostatic spiral; C - Rocker; D - Fast idle adjusting screw; E - Engine water manifold; F - Pickup levers connected with carburettor throttle; G - Carburettor; H - Pin.

ADJUSTING PROCEDURE

For checking and adjusting the fast idle speed with hot engine, it is necessary:

- to remove air filter box.
- To hold the microswitch lever (see fig.9) in the position towards the microswitch body thus operating the distributor retarded breaker points R2.
- To warm the engine in neutral until water temperature is about 82°C (do not accelerate too much).
- By a key on the cam pin, rotate the cam until the number 20 marked on the cam corresponds to the rocker arm on which is an adjusting screw.
- To adjust the adjusting screw until the engine runs at 3400 ± 300 RPM. In this way the engine, when cold, will run at 3100 ± 300 RPM.
- To release the microswitch lever and adjust it according to its adjusting procedure shown in heading "MICROSWITCH ADJUSTING", page 07.

SPARKING PLUGS (CHAMPION N 7 Y)

With the engine idling, inspect for spark plugs caps discharges.

If the car is frequently driven in unusual traffic conditions, inspect every 14500 km. each plug individually for badly worn electrodes, glazed, broken or blistered porcelains.

Clean plug electrodes and adjust the gap. Replace the spark plugs if necessary.

The extensions fitting on the spark plugs must be effected by hand. Prior to fitting the plugs make sure that their threads are lightly coated with graphite grease.

If the sealing washer is new, first tighten to a maximum torque of 1,5 kgm. then slacken and re-tighten to 2 kgm.

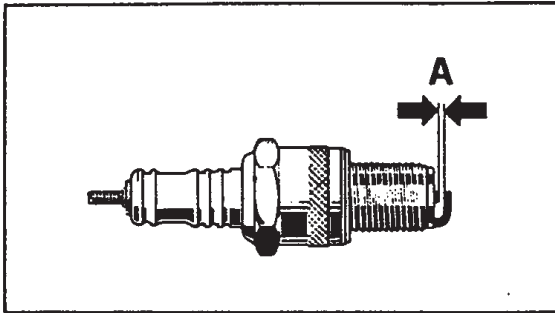
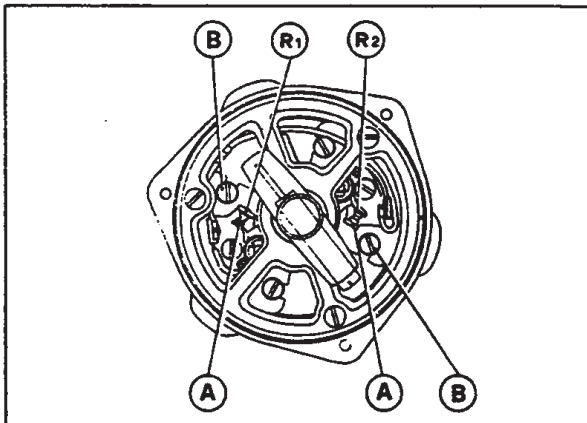

Fig. 5 - CHECKING THE PLUGS GAP.
A = 0,4 + 0,6 mm.

IGNITION DISTRIBUTORS MARELLI S 159 B



The ignition system has two distributors, one for each cylinder row, having each one two breaker points: one retarded (R2) and one advanced (R1).

The ignition impulse is generated by R1 or R2 breaker point according to the position of a microswitch operated by the carburettor or throttle (see fig.7); i.e., when accelerating the engine from idle, the throttle operates on the lever of the microswitch that opens the circuit and makes operational the contact (R1) advanced.

Fig.6 - IGNITION DISTRIBUTOR.

DISTRIBUTOR SERVICE

Check:

- Cleaning and gap of the breaker points (gap: 0,32 + 0,38 mm. for R1 and 0,30 + 0,40 mm. for R2).
- Correct condenser working.
- Distributor caps and wires.
- Cam lubrication.
- Ignition timing and dwell.
- Advance mechanism.

Ignition timing and dwell setting procedure.

- Basic ignition timing: $3^{\circ} \pm 2^{\circ}$ ATDC at 1000 ± 200 RPM in neutral.
 - Dwell: on advanced breaker point R1 + $39^{\circ} \pm 3^{\circ}$.
- On advanced breaker point R1, with retarded wire R2 disconnected from ground $34^{\circ} \pm 3^{\circ}$.

PROCEDURE

- 1 - Make sure that the ignition system wires are correctly connected
- 2 - Hold the microswitch lever (which connects the retarded breaker point of the distributor) in the position towards the microswitch body thus assuring that the retarded breaker point is certainly connected.
- 3 - Connect the tachimetric revolution counter provided with an appropriate dwell angle measuring instrument to the distributor advanced point and the stroboscopic lamp to engine by using the

spark plug wire of cylinder no. 1 for right distributor and no.5 for the left one.

- 4 - Start the engine and after warm-up check (with the engine at idle speed of 1000RPM) that the dwell angle is $39^{\circ} \pm 3^{\circ}$. Repeat this operation still having the rev counter connected to the advanced breaker point, after having disconnected from the retarded breaker point the wire connected with the microswitch and make sure that at the same engine speed the dwell angle is $34^{\circ} \pm 3^{\circ}$. Then connect again the retarded breaker point. Check in the same way the other distributor.

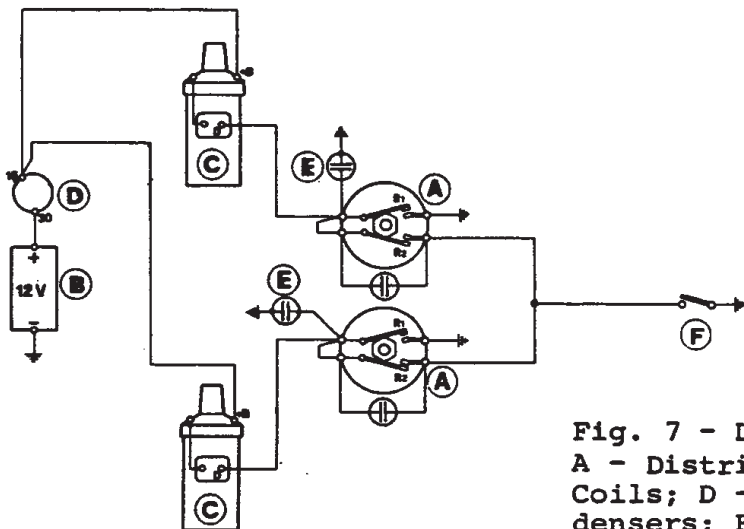

Fig. 7 - DIAGRAM of IGNITION CIRCUIT
A - Distributors; B - Battery; C - Coils; D - Ignition switch; E - Condensers; F - Microswitch.

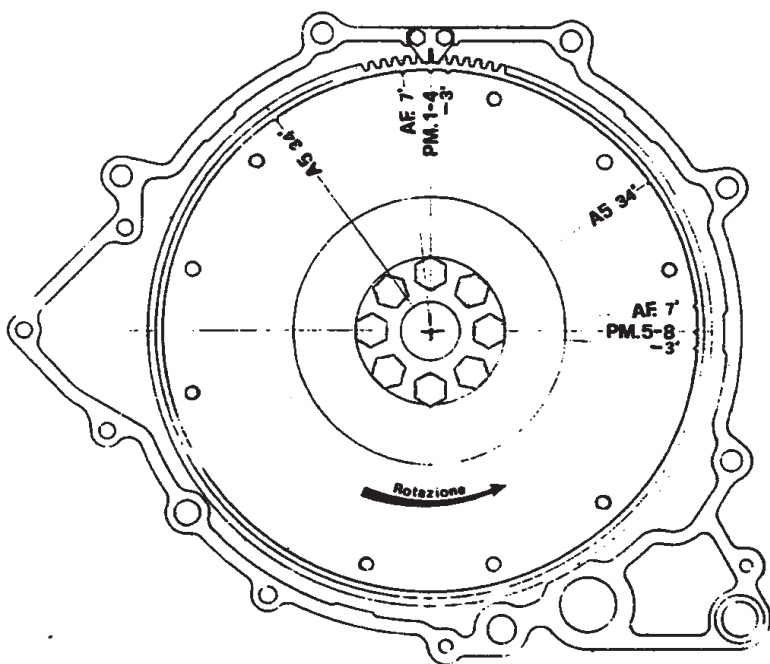

Fig. 8 - FLYWHEEL MARKS
for IGNITION
CHECKING

- 5 - In case of wrong setting, proceed by putting the distributor cam in position from which the maximum opening of breaker point derives. Then loosen the screw of the fixed contact and adjust breaker points gap. Check again the dwell angle. Re-tighten securely the fixing screw.
- 6 - Check ignition timing with stroboscopic lamp ascertaining through the slit on the engine flywheel housing that the degrees pre-scribed and marked on the flywheel (3° ATDC) correspond to the fixed index located in the slit. This operation is to be made on both distributors using the spark plugs of cylinders no. 1 and no. 5 alternatively.
- 7 - If distributor setting results to be not correct, manually loose and rotate it until correct setting is achieved and then tighten it.
- 8 - Release the microswitch lever for the normal operation.

ADJUSTMENT OF MICROSWITCH UNIMAX 2H BF - 113-1

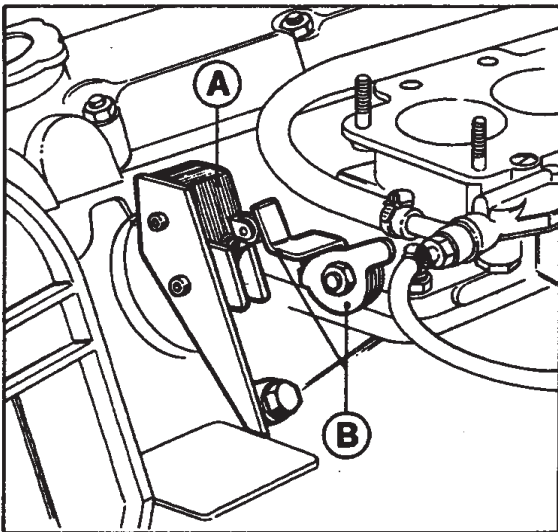

Fig. 9 - MICROSWITCH CONTROL of the DISTRIBUTORS RETARDED POINTS
A - Microswitch; B - Microswitch control lever.

- Connect a normal revolution counter to breaker point R1 of one distributor and an electric tester between the microswitch contact and ground.
- With the gear in neutral open by hand, directly on the lever, the carburettor throttle very slowly.
- The passing from the retarded point to the advanced, which corresponds to a signal of the electric tester, takes place at the throttles position corresponding to the engine RPM in neutral of 3900 ± 200 RPM.

WARNING

Check the correct working of the microswitch and the correct passing from R2 to R1 breaker point because it would be dangerous for the engine itself if the retarded point would be inserted until the maximum RPM of the engine.

ADVANCE CURVE CHECKING

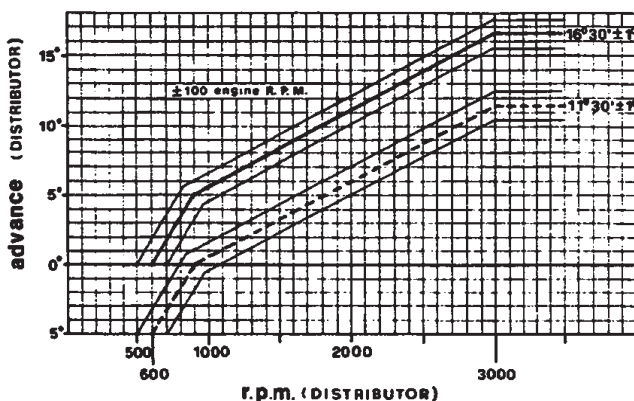

Fig. 10 - AUTOMATIC ADVANCE CURVE.

— Theoretical automatic advance curve - advanced breaker point (R1).

----- Theoretical automatic advance curve - retarded breaker point (R2).

- With the gearbox in neutral, accelerate from idle to 5000 RPM and using a stroboscopic lamp connected to the spark plug wire of cylinder no. 1 (or no. 5 for the other row), check through the slit on the flywheel housing that the advance is $34^{\circ} \pm 2^{\circ}$.
- If not, remove the distributor from the engine and put it on the advance distributor checking bench. The advance curve on the advanced breaker point R1 must be between the tolerance limits prescribed (see fig. 10 - advance curve).
- If not, have a general overhaul of the distributor. Check also the advance curve of the retarded breaker point R2. It must be in every point in retard of 5° of distributor in comparison with the advanced breaker point R1. If not, proceed at the operations described in paragraph 5.
- Repeat the same inspection on the second distributor.

EXHAUST EMISSION CONTROL SYSTEM

MAIN SPECIFICATIONS

Air injection and thermal reactor.		
Air pumps	No. 2	G.M. 7817815 PUMP ASSY
Air pumps belts	No. 1 Front	GATES POLIFLEX 7M 1030
	No. 1 Rear	GATES POLIFLEX 7M 500
Check valves	No. 2	G.M. 5354987
Diverter valves	No. 2	G.M. 7030761

AIR INJECTION SYSTEM

The functional principle of the system is to convey air into the exhaust manifolds so that the oxygen of the air reacts with the hot exhaust gases causing further combustion in the exhaust system.

The components of the system are the following :

- Two air pumps (driven by the engine through belts) to supply the air into the exhaust manifolds.
- Two diverter valves, one for each air pump.
- Two check valves (one for each air pump) to protect the system from hot gases.
- Air injection manifolds.
- Air injectors at the exhaust port near the exhaust valves.

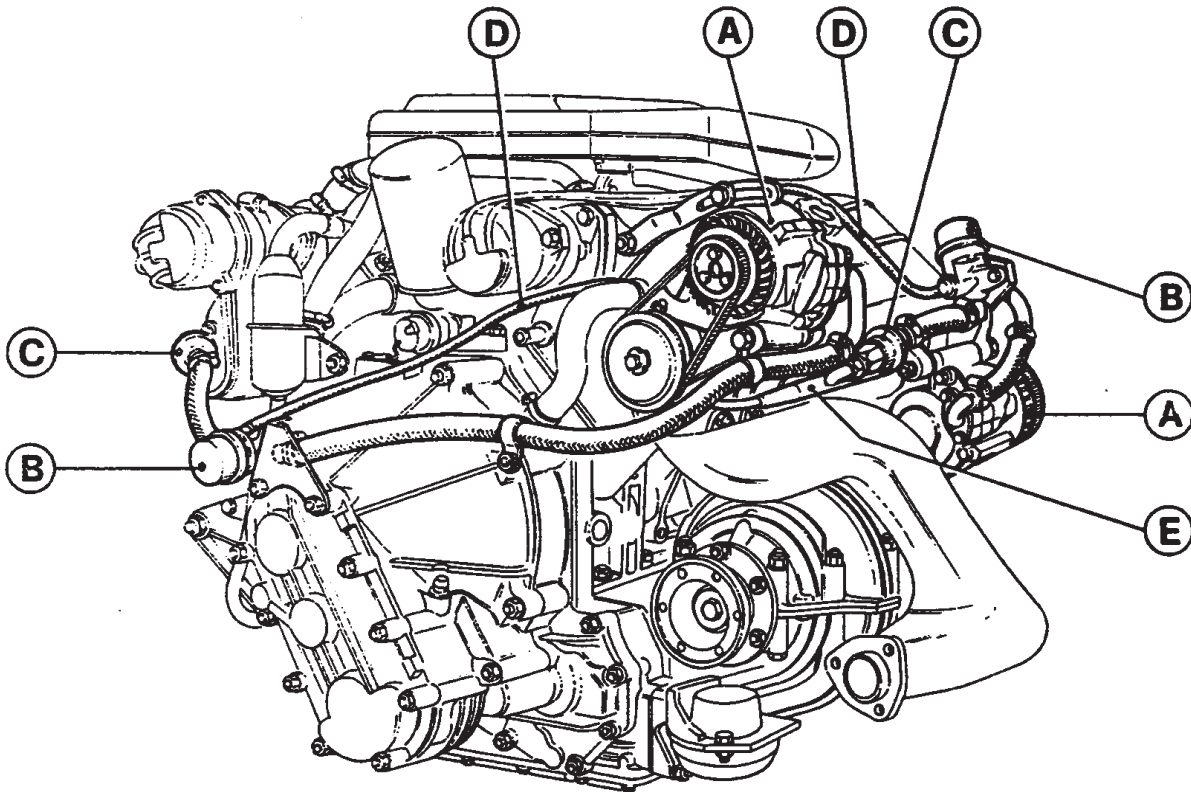

Fig. 11 - AIR INJECTION SYSTEM.

A - Air pumps; B - Diverter valves; C - Check valves; D - Depression line for for diverter valve connected to the rear inlet manifold; E - Air injection manifold for cylinders Nos. 1-2-3-4.

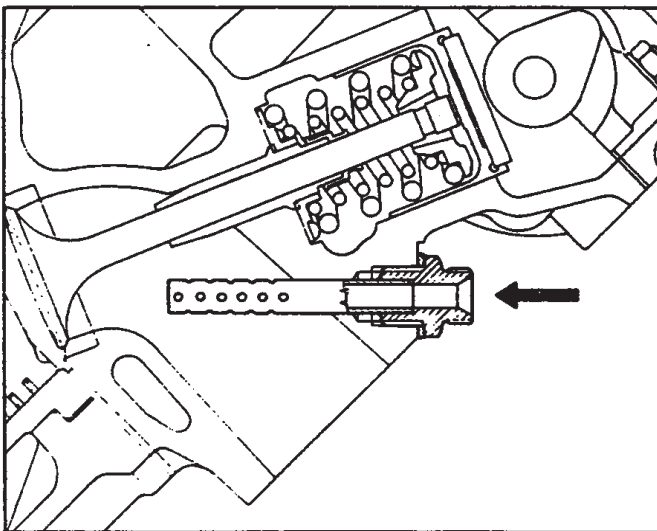

Fig. 12 - AIR INJECTOR NOZZLE.

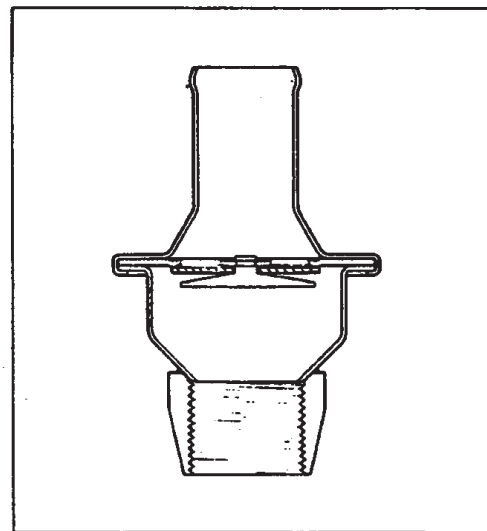

Fig. 13 - CHECK VALVE.

AIR PUMPS

The air pumps (fig. 11) compress fresh air through the injectors and relevant pipes in the system near the exhaust valves. This inlet of air burns the unburnt exhaust gases thus reducing the HC and CO percentage.

CHECKING AND SERVICE

- Connect a pressure gauge to the line downstream the diverter valve and check the air pump pressure. It must be 4+6 meters of H₂O at 5000 RPM of engine in neutral. If not, check for leaks the lines or the diverter valve.
Replace the air pumps or the diverter valves if necessary.
- Do not attempt to lubricate the pumps in any way.
- Do not attempt to open the pumps.
- Do not attempt to clean the centrifugal filter with the pump on the engine.

INSTRUCTIONS FOR AN EVENTUAL REPLACEMENT OF AIR PUMPS FILTER

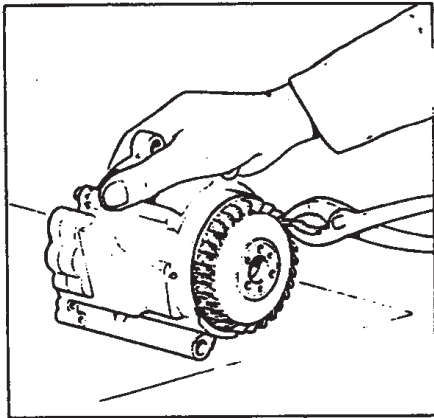

Fig. 14 - REMOVING of CENTRIFUGAL FILTER

Proceed as follows:

- Remove drive belt;
- remove the pulley from the pumps;
- pull off the centrifugal filter fan with slip joint pliers (see fig. 14);
- do not attempt to remove the metal drive hub;
- install a new filter fan by drawing it into position using the pulley and bolts as an installer.

AIR PUMP BELT ON VALVE GEAR SIDE

TENSION MANUAL CHECKING

The deflection A of the belt in the middle of the two pulleys does not exceed 6 mm. with a load of 1 kg. for a new belt and 0,7 kg. for a run-in belt.

CHECKING BY TENSIO METER

The tension of a new belt should be 13,5 kg. read on scale 7M of tensiometer "GATES 150 type". With used belt the charge should be 11,5 + 13,5 kg.

To increase the belt tension, slacken the nut C on the adjusting bracket, move the air pump upward and retighten the nut.

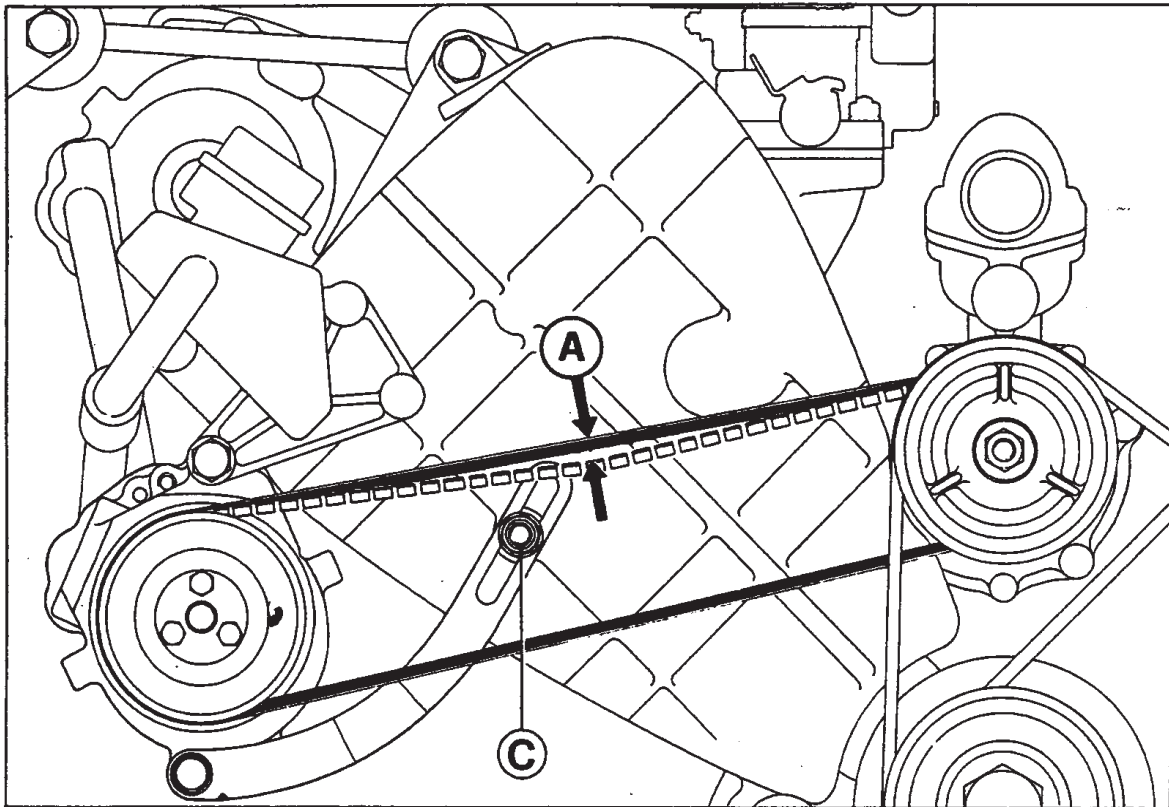

Fig. 15 - AIR PUMP BELT ON VALVE GEAR SIDE.

AIR PUMP BELT ON CLUTCH SIDE

TENSION MANUAL CHECKING

The deflection B of the belt in the middle of the two pulleys does not exceed 1,5 mm. with a load of 1,3 kg. for a new belt and 0,9 kg. for a run-in belt.

CHECKING BY TENSIO METER

The tension charge of a new belt should be 19 kg. read on scale 7M of tensiometer "GATES 150 type". With used belt the charge should be 16 + 19 kg.

To increase the belt tension, slacken the screw D on the adjusting bracket, move the air pump upward and retighten the screw.

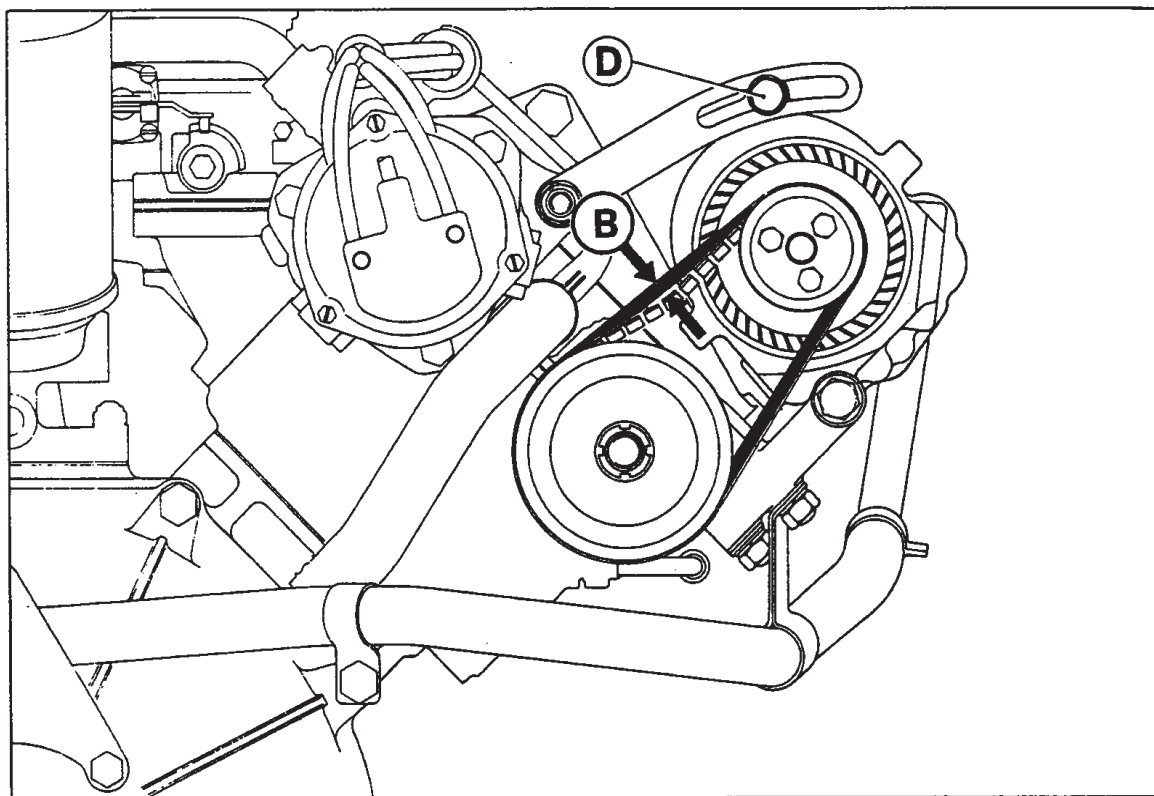

Fig. 16 - AIR PUMP BELT ON CLUTCH SIDE.

DIVERTER VALVES

The diverter valves have the following functions:

- a) The relief valve, made of a spring and of a rubber head, blows the air outside during the engine accelerations or in case of occlusion of the air injection circuit when the delivery air pump pressure reaches values higher than the spring load ($0,40 + 0,55 \text{ kg/cm}^2$).
- b) Air outlet system during decelerations to avoid back-fire in the exhaust system. This system is made of a rubber stem, of a rubber membrane, of a spring and of a chamber receiving a signal of vacuum from the intake manifold during deceleration. By this signal the stem, connected with the membrane, shuts off the air delivery to the engine and the air is blown outside.

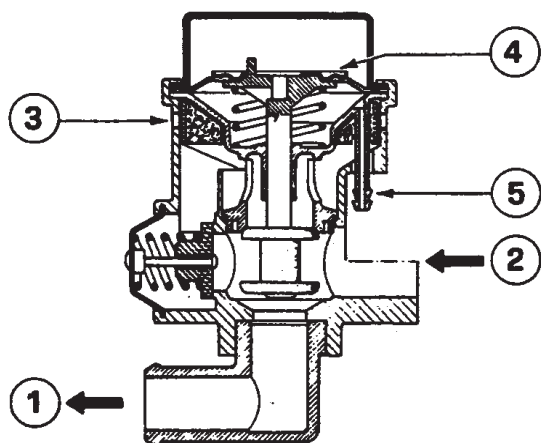

Fig. 17 - DIVERTER VALVE.
1 - Outlet; 2 - Inlet; 3 - Diverted air outlet; 4 - Membrane
5 - Signal line connection.

CHECKING AND SERVICE

Dismount the valves and visually check that no failure or deformation is evident. Clean the internal passage and giving a vacuum signal of to 200 + 250 mm.Hg. to the vacuum line, check the correct working of the rubber membrane. If the valve has some defect, replace. Check the hoses and connections for conditions; replace if their integrity is not satisfactory.

EVAPORATIVE EMISSION CONTROL SYSTEM

MAIN SPECIFICATIONS

Sealed filter cap	No. 1	FERRARI 101453
Limiting filling tanks	No. 2	With a vapor storage chamber on the top of each tank.
Vapor liquid separator	No. 1	FERRARI 107606
Three-way valve	Type	BORG WARNER CUX 2219
Activated carbon trap	Type	ARATO No. 1401

The release of fuel vapors from tank into the atmosphere is prevented by a proper system through which vapors are conveyed to an activated carbon trap in engine compartment where they are absorbed. During engine operation, a hot air stream regenerates the activated carbon from which the gasoline vapors are extracted and conveyed to the intake manifold.

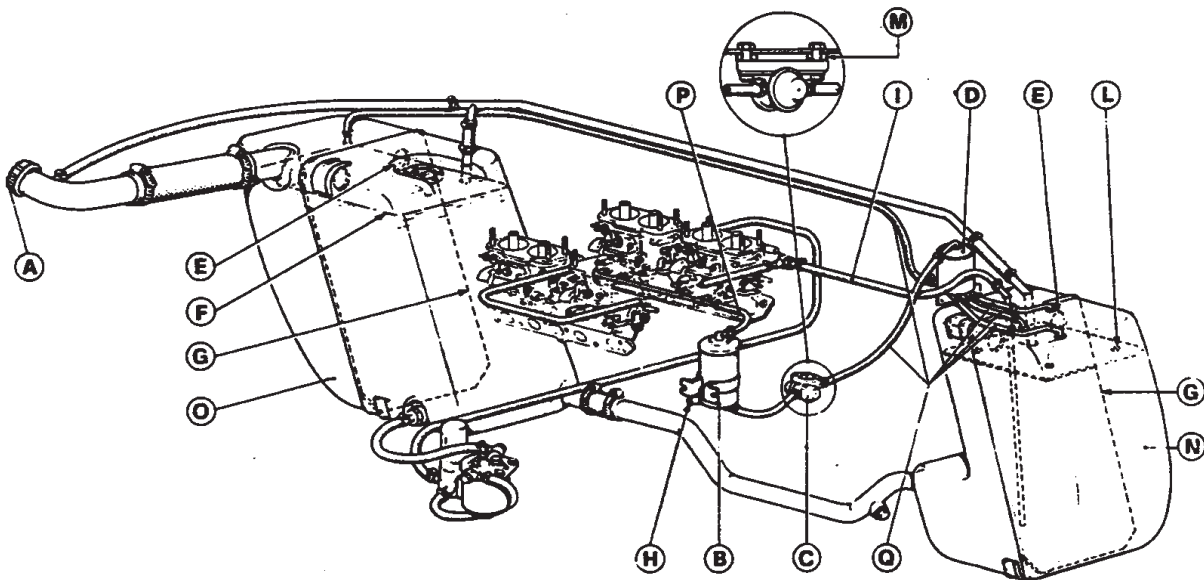

Fig. 18 - EVAPORATIVE EMISSION CONTROL SYSTEM.

A - Sealed cap; B - Activated carbon trap; C - Three-way control valve; D - Liquid vapor separator; E - Gasoline vapor holes; F - Maximum fuel level; G - Vertical wall; H - Hot air purge tube; I - Fuel return pipe from carburetors; L - Vapors breather holes; M - Spacer; N - Right fuel tank; O - Left fuel tank; P - Vapor vent line to carburetor downstream of throttle; Q - Vapor vent line.

The system consists essentially of:

- Sealed filler cap.
- Limited-filling tank.
- Tank outlet line and vapor-liquid separator (see fig. 21).
- Three-way valve performing the following tasks (see fig. 19):
 - slight tank pressurization;
 - air inlet into tank to prevent any possible vacuum;
 - safety exhaust to prevent undue over pressure in tank.
- Charcoal canister (activated carbon trap)(see fig. 20).
- Hot air purge tube.
- Vapor vent lines to carburettor downstream of throttle.
- Fuel return pipe from carburettors.

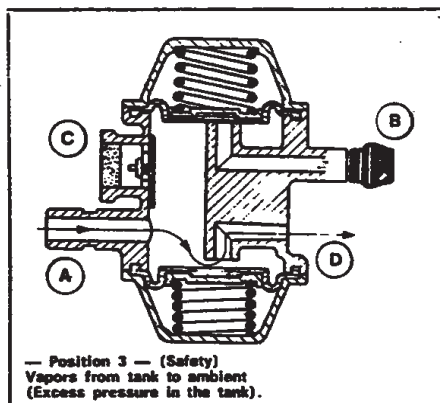
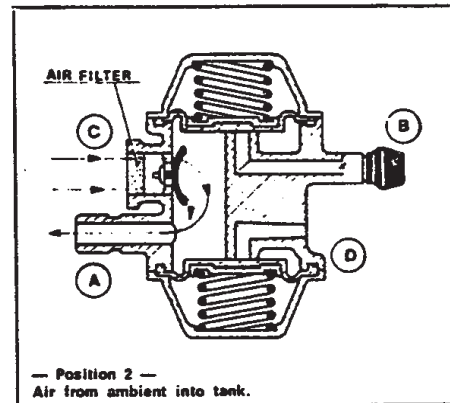
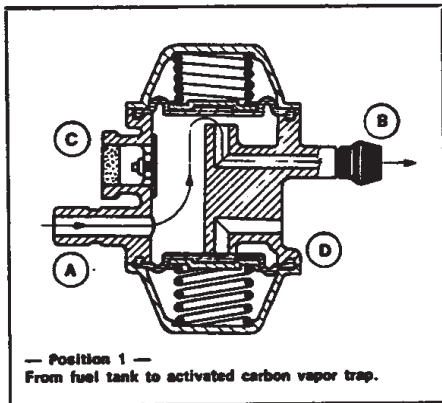

Fig. 19 - THREE-WAY CONTROL VALVE.
A - From fuel tank.
B - To activated carbon trap.
C - Fuel tank air inlet.
D - Safety outlet.

SERVICE

Check and clean hoses, lines and connections.
Check by a manometer that the three-way valve keeps a pressure of 310 + 360 mm. H₂O for 5 minutes approximately. Replace valve if necessary.

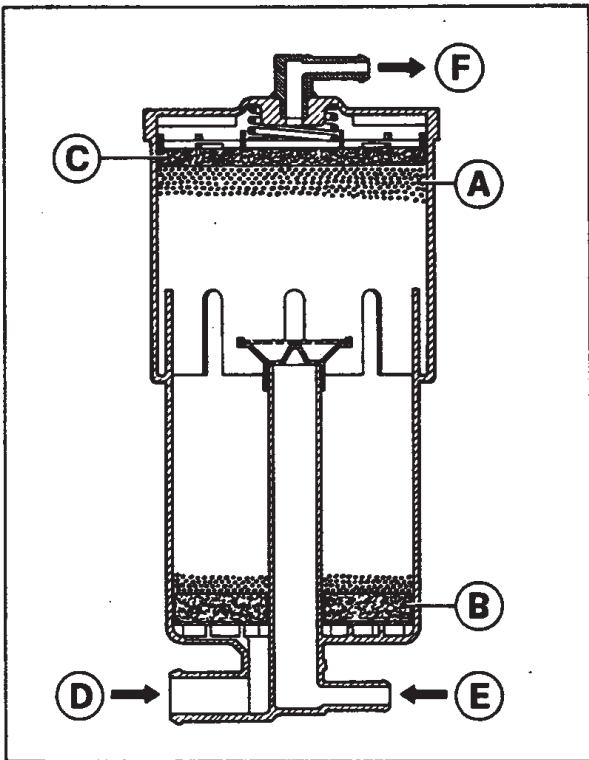

Fig. 20 - ACTIVATED CARBON TRAP
 A - Activated carbon; B - Air
 purge filter; C - Synthetic fil-
 ter; D - Hot air purge inlet;
 E - Fuel vapors inlet; F - To
 engine intake manifold.

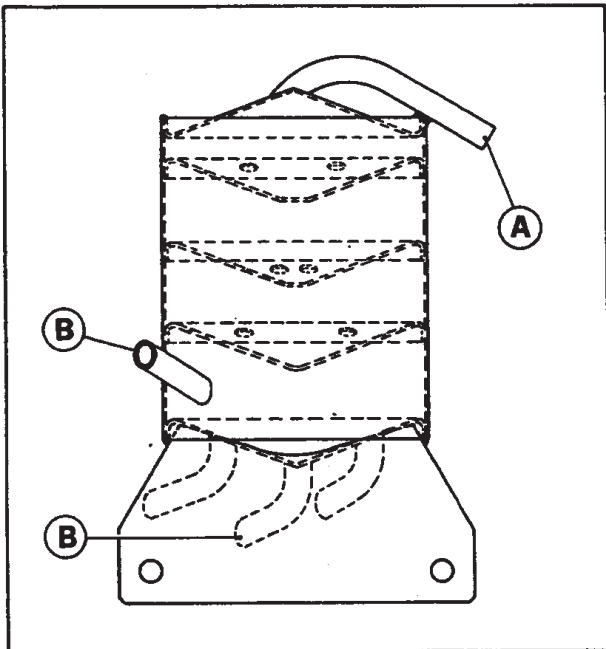

Fig. 21 - LIQUID VAPOR SEPARATOR
 A - Vapor outlet; B - Vapor in-
 let.

ELECTRICAL SYSTEM

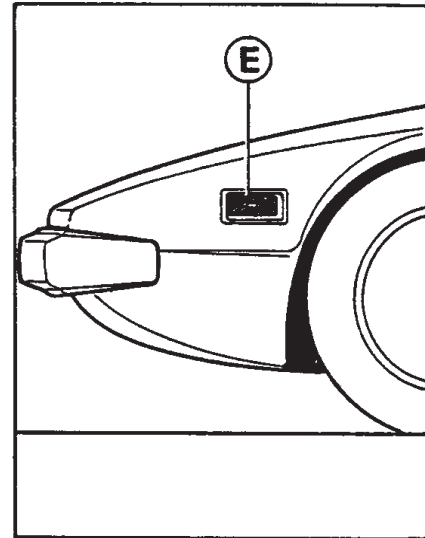
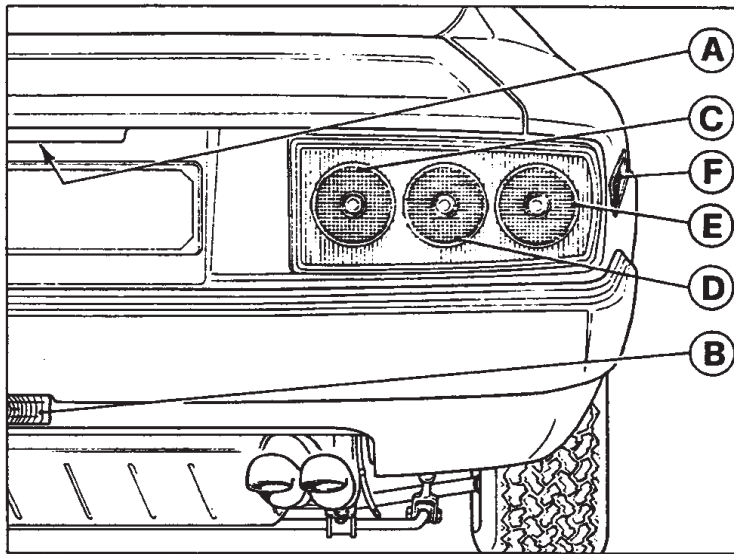

Fig. 22 - FRONT LIGHTS.

A - Parking light; B - Direction light; C - Headlamp main beam; D - Headlamp dipped beam; E - Side marker.

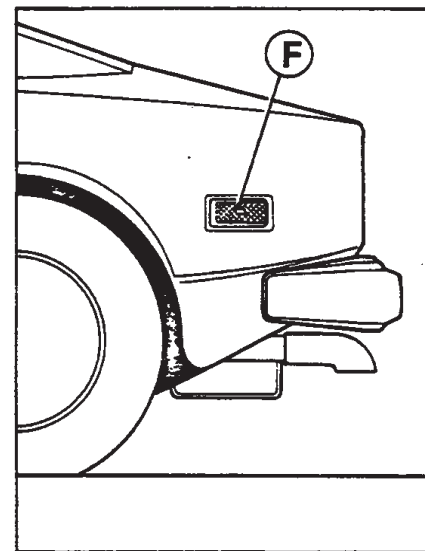
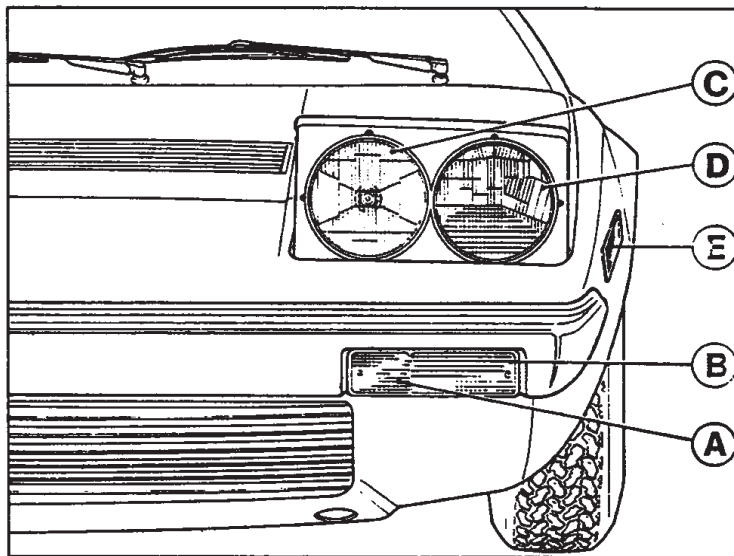

Fig. 23 - REAR LIGHTS.

A - Number plate light; B - Reverse light; C - Reflex reflector; D - Parking and stop light; E - Direction light; F - Side marker.

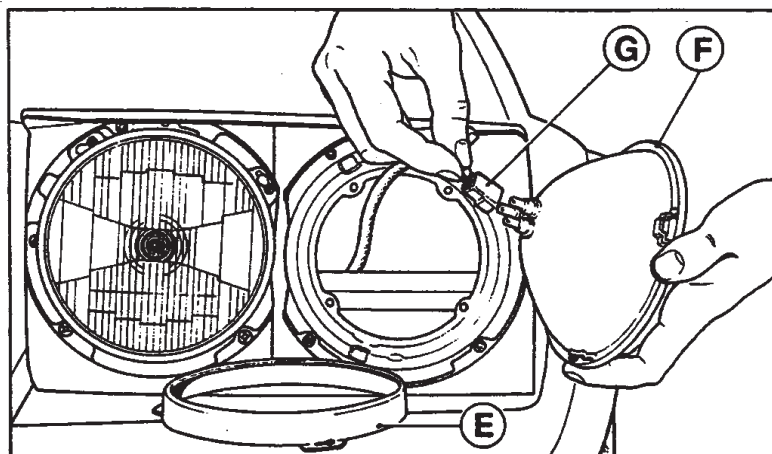

Fig. 24 - CHANGING HEADLAMPS.

E - Headlamp fixing ring;
F - Reflector assembly;
G - Headlamp electric connection.

BULBS (main specifications)

BULBS (use)	TYPE	WATTAGE (12 V)
Headlamp main beam Headlamp dipped beam	Sealed Beam	37,5 60/37,5
Parking and stop rear lights Parking and direction front lights	Spherical double filament (SAE type 1034-3/32 cp)	5/21
Rear direction lights Reverse lights	Spherical (SAE type 1073/32 cp)	21
Number plate lights	Spherical (SAE type 67/4 cp)	5
Engine compartment light Interior light (in roof) Front ash-tray light	Cylindrical	5
Open door marker light	Tubular	4
Unfastened safety belts warning light	Tubular	3
Front and rear side markers	(SAE type 158/2 cp)	4
Instruments lights (speedometer excluded) Fuel reserve warning light Warning light for brake system failure Headlamp main beam warning light	Tubular	3
Thermic window warning light Electric fan motors indicator (FAN) Emergency lights indicator Electronic speedometer lighting Direction lights indicator Parking lights indicator Generator charge indicator	Tubular	1,2
Glove box lighting	Cylindrical	10

FUSES AND RELAYS

LEFT BOX

- 1 - A16: Windscreen wiper - Wind screen washer - Direction indicator lights - Stop lights - Relays for radiator fans and windows motors.
- 2 - A8: Instruments - Reverse light - Interlock system.
- 3 - A8: Electric pump.
- 4 - A16: Thermic rear window.
- 5 - A25: Heater fan motors - Air conditioning system.

RIGHT BOX

- 10 - A8: R.H. main beam.
- 11 - A8: L.H. main beam and relevant warning light.
- 12 - A8: R.H. dipped beam.
- 13 - A8: L.H. dipped beam.
- 14 - A8: Front right and rear left parking lights - Number plate light - Parking lights indicator - Engine compartment lights - Ash-tray light.

- 6 - A16: Vehicular hazard warning lights - Interior lights
Open-doors marker lights -
electric aerial motor - Lamp
receptacle.
- 7 - A16: Headlights motors.
- 8 - A25: R.H. window motor.
- 9 - A25: L.H. window motor.
- 15 - A8: Front left and rear right
parking light - Number plate
light - Instruments light.
- 16 - A25: Horns - Cigarette light
er - Clock - Ignition key
buzzer.
- 17 - A25: R.H. fan motor.
- 18 - A25: L.H. fan motor.

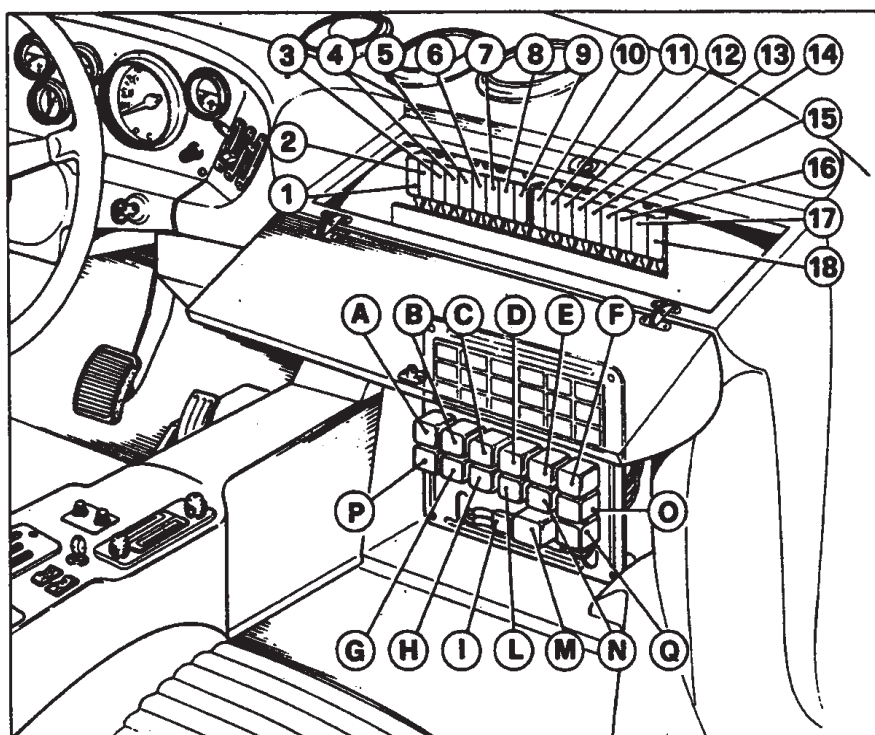

Fig. 25 - FUSES and RELAYS.

RELAYS

- A - Relay for radiator left fan (BOSCH 0332014113).
- B - Relay for radiator right fan (BOSCH 0332014113).
- C - Relay for radiator right fan with operating air conditioning (BOSCH 0332014113).
- D - Relay for external lights (STRIBEL SR 9833).
- E - Main beam relay (STRIBEL SR 9833).
- F - Relay for brakes warning light (BOSCH 0332014113).
- G - Relay for window motor (BOSCH 0332014113).
- H - Warning horn relay (BOSCH 0332014113).
- I - Terminal boards protection (AMP PN 280043).
- L - Relay for headlamps lifting motor (BOSCH 03322040101).
- M - Relay for emergency flashing 12V-2 (4)x21W (BOSCH 033520-0012).
- N - Relay for L.H. headlamps lifting motor (BOSCH 033220-4101).
- O - Relay for R.H. headlamps lifting motor (BOSCH 033220-4101).
- P - Relay for unfastened safety belts buzzer (BOSCH 0332014-113).
- Q - Engine starting relay (BOSCH 0332014113).

WIRING DIAGRAM

- | | |
|--|--|
| 1 - | 40 - Electronic speedometer. |
| 2 - Sealed main beam. | 41 - Oil pressure gauge. |
| 3 - Sealed main and dipped beams. | 42 - Oil temperature gauge. |
| 4 - Parking and direction indicator lights. | 43 - Water temperature gauge. |
| 5 - Front and rear parking indicators (side markers). | 44 - Electronic revolution counter. |
| 6 - Alternator. | 45 - Fuel level gauge. |
| 7 - | 46 - Clock. |
| 8 - Ignition distributor. | 47 - Alternator charge warning light. |
| 9 - Ignition coil. | 48 - Thermic window warning light. |
| 10 - Starter motor. | 49 - Fuel reserve warning light. |
| 11 - Horn relay (20A-12V). | 50 - Warning light for brake system failure. |
| 12 - Sending unit for water temperature gauge. | 51 - L.H. direction lights indicator. |
| 13 - Sending unit for oil temperature gauge. | 52 - R.H. direction lights indicator. |
| 14 - Sending unit for oil pressure gauge. | 53 - Parking lights indicator. |
| 15 - Engine compartment light. | 54 - Handbrake warning light. |
| 16 - Enginelight switch. | 55 - Headlamp main beam warning light. |
| 17 - Battery. | 56 - Glove-box lighting. |
| 18 - Reverse light switch. | 57 - Glove-box light switch. |
| 19 - Stop light switch. | 58 - Open-doors marker lights. |
| 20 - Fuse boxes. | 59 - Interior lights fitted on doors. |
| * 21 - Interlock system control switch for safety belts (closes when engaging gears) | 60 - Ash-tray with courtesy lamp |
| 22 - Windscreen wiper motor. | 61 - Electric cigarette-lighter. |
| 23 - L.H. heater electric fan motor. | 62 - Handbrake warning light switch. |
| 24 - Heater fan motor switch. | 63 - Flasher for direction indicators and vehicle hazard lights. |
| 25 - R.H. heater electric fan motor. | 64 - Thermic rear window switch. |
| 26 - | 65 - Warning horn switch. |
| 27 - L.H. radiator cooling motor. | 66 - Thermic rear window. |
| 28 - R.H. radiator cooling fan motor. | 67 - Vehicle hazard warning lights. |
| 29 - Relay switch for L.H. radiator cooling fan motor. (12V - 20A). | 68 - Screen washer pump. |
| 30 - Relay switch for R.H. radiator cooling fan motor. (12V - 20A). | 69 - Door jamb switch for interior lights and open-door marker lights. |
| 31 - Relay (12V - 20A) for unfastened safety belt buzzer. | 70 - Interior light with incorporated switch. |
| 32 - Rheostat and switch for instrument lights (4,5Ω). | 71 - Fuel level sender unit. |
| 33 - Direction indicator switch. | * 72 - Electronic unit for safety belts system and starting lock. |
| 34 - Main/dipped beam change over and flash switch. | * 73 - Relay (12V-20A) for engine starting. |
| 35 - Windscreen wiper and washer pump three positions switch lever. | 74 - Sparking plugs. |
| 36 - Parking lights switch. | 75 - Relay switch for L.H. head lamps lifting motor (12V - 20A). |
| 37 - Ignition switch with anti-theft device. | 76 - Relay switch for R.H. head lamps lifting motor (12V - 20A). |
| 38 - Vehicle hazard warning light switch. | |
| 39 - | |

- 77 - Thermostatic control switch for radiator fans motor.
- 78 - Radio suppressor capacitor (2,2 μ F) for alternator.
- 79 - Radio suppressor capacitor (1 μ F).
- 80 - Radio (Optional).
- 81 - Electric aerial motor (Optional).
- 82 - Radio receiver protection fuse (5A) (Optional).
- 83 - Relay (12V - 20A) controlling indicator 50 efficiency
- 84 - Loudspeakers inside the doors (Optional).
- 85 - Electric aerial motor control switch (Optional)
- 86 - Electric fuel pump.
- 87 - Relay for headlamps (12V - 20A).
- 88 - Main beam lighting relay (12V - 20A).
- 89 - Horn compressor motor.
- 90 - Switch on driver's safety belt (open with fastened belt).
- * 91 - Switch under driver's seat (closed with seated driver)
- 92 - Lamp receptacle.
- 93 - L.H. window control switch (Optional).
- 94 - L.H. window operating motor (Optional).
- 95 - R.H. window control switch (Optional).
- 96 - R.H. window operating motor (Optional).
- 97 - Relay 12V-20A for windows motor control, only with the key inserted in the anti-theft device (Optional).
- 98 - Air conditioner compressor (Optional).
- 99 - Relay switch for right radiator fan motor when air conditioner is engaged (Optional).
- 100 - Rotary knob control air conditioner fan speed (Optional).
- 101 - Thermostat for air conditioner compressor 98 and cooling fan control 28 (Optional).
- 102 - Cooler unit fan motor (Optional).
- 103 - Control switch for oil pressure in brake system.
- 104 - Headlamp lifting motor.
- 105 - Relay switch for headlamp lifting motors.
- 106 - Microswitch on the pin controlling carburettor throttle opening.
- 107 -
- 108 - Instrument side panel lights.
- 109 - Electric fan motors indicator.
- 110 - Resistor for air conditioner fan speed control (Optional).
- 111 - Max. pressure switch for air conditioner (Optional)
- 112 - Min. pressure switch for air conditioner (Optional)
- * 113 - Switch under passenger's seat (close with seated passenger).
- * 114 - Switch on the passenger's safety belt (open with fastened belt).
- 115 - Stop and rear parking lights.
- 116 - Rear direction indicator lights.
- 117 - Rear reflector.
- 118 - Number plate lights.
- 119 - Reverse lights.
- 120 - Plug adaptor.
- ** 121 - Warning device for unfastened safety belts. (SIPEA).
- 122 - Impulse generator for electronic speedometer.
- 123 - Unfastened safety belt warning light.
- 124 - Buzzer operating with unfastened safety belts and ignition key forgotten in the lock.
- 125 - Switch on door pillar for buzzer with key in lock.

* Valid up to car No. 10176

** Valid from car No. 10178

MODIFICATION TO THE WIRING DIAGRAM REGARDING SAFETY BELTS USE;

Starting from car No. 10178, the wiring diagram has been simplified as shown in fig. 28 since the interlock system and relevant connections have been removed.

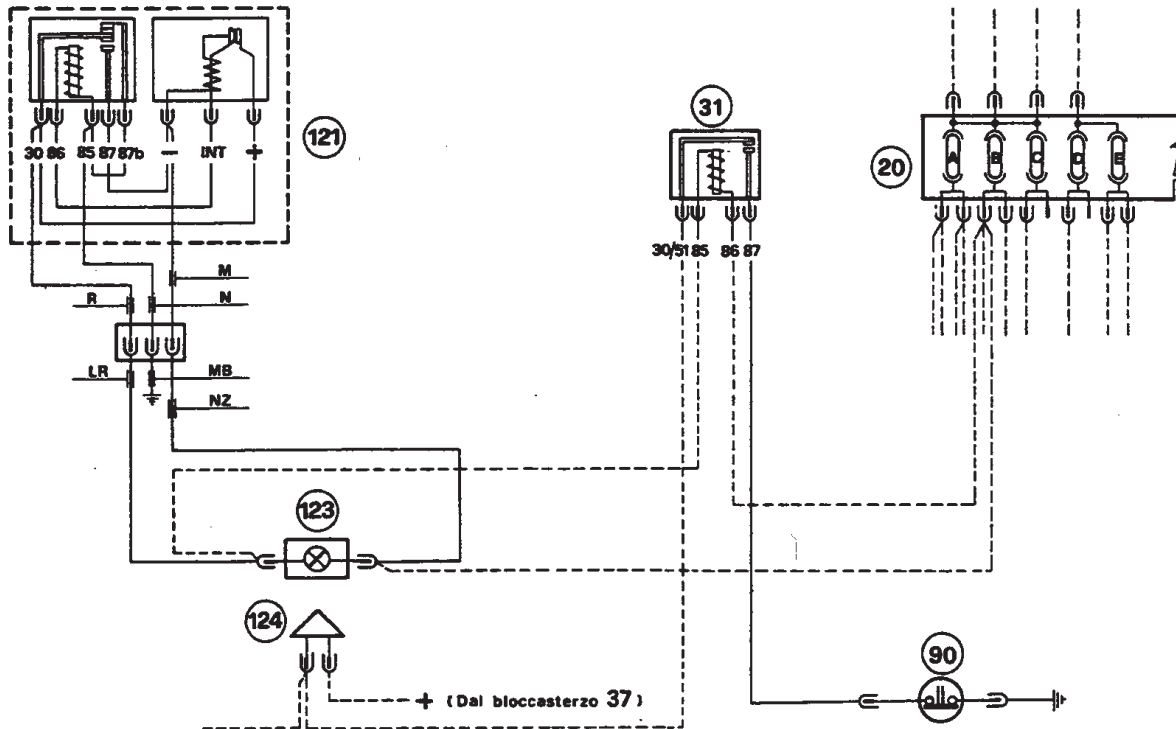

Fig. 28 - SEAT BELTS ELECTRIC SYSTEM (From car No. 10178).

Note - The dashed line shows the wires already existing (see fig.26)
Regarding numbers shown in fig. 28, see the wiring diagram list in page O

OPERATING INFORMATION

The driver seats in the car and turns the key to position ON or START. The warning light "FASTEN SEAT BELTS" will operate for 4-8 seconds with fastened or unfastened seat belts. At the same time, the buzzer will operate but only in case the driver has not properly fastened the seat belt. Warning light and buzzer are not in connection with passenger seat.

COLOURS OF WIRING DIAGRAM CABLES

A - Azure	GN - Yellow striped black
B - White	HN - Grey striped black
C - Orange	VN - Green striped black
G - Yellow	AR - Azure striped red
H - Grey	HR - Grey striped red
L - Blue	AB - Azure striped white
M - Brown	RN - Red striped white
N - Black	MN - Brown striped black
R - Red	GR - Yellow striped red
S - Pink	GV - Yellow striped green
V - Green	CN - Orange striped black
Z - Violet	LN - Blue striped black
AN - Azure striped black	BR - White striped red
BN - White striped black	MB - Brown striped white