

Top Reliability: Cylinder-head gasket and cylinder-head bolts all from one supplier



GOOD EXPERIENCE

# Cylinder-Head Bolts

A Practical Guide



Das Original

# Reliability is not a flexible term

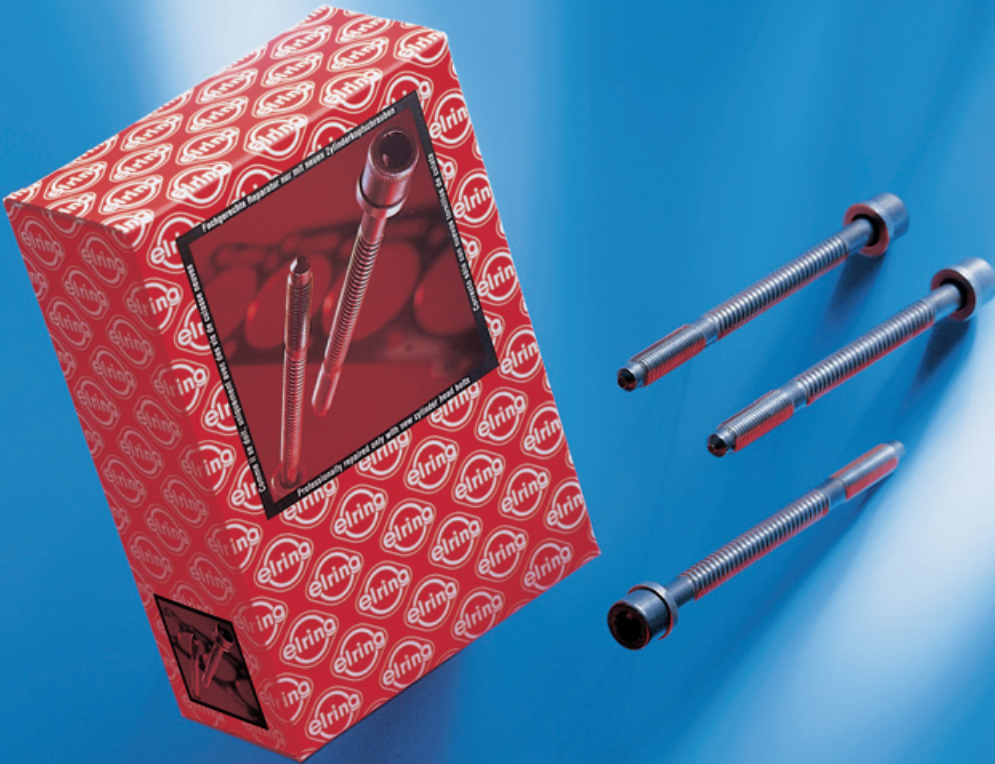

*The right turn for optimal reliability*

## Elring – even better service.

For the current generation of engines, the professional repairing of the cylinder head sealing system requires that both components – cylinder-head gasket and cylinder-head bolts – be replaced with new parts.

With the new full range of cylinder-head bolts from Elring, you save time and money. Because now everything is available from one supplier: the cylinder-head gasket and the matching cylinder-head bolt set

- for practically all cars and commercial vehicles (see Cylinder-Head Bolt catalogue)
- of tested quality
- assortments selected individually for each engine repair
- packed in a special box with thread protection
- practical and fast
- direct from the gasket manufacturer

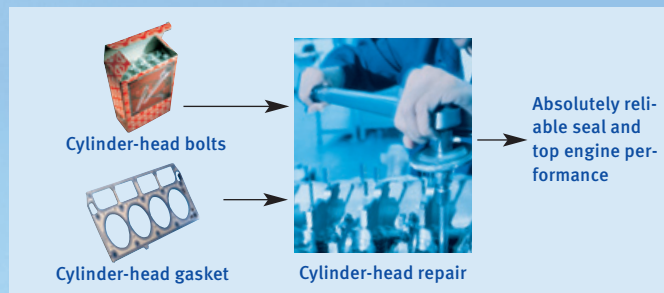

### Elring cylinder-head bolts are available for:

Alfa Romeo | Audi | BMW | Citroën | Daewoo | Deutz |  
Fiat | Ford | Honda | Hyundai | Isuzu | Iveco |  
Kia | Lada | Land Rover | Lancia | MAN | Mazda |  
Mercedes-Benz (cars and commercial vehicles) |  
Mitsubishi | Nissan | Opel | Peugeot | Renault |  
Rover | Saab | Scania | Seat | Škoda | Ssangyong |  
Suzuki | Talbot | Toyota | Vauxhall | Volkswagen |  
Volvo (cars and commercial vehicles)

### Contents: Cylinder-Head Bolts – A Practical Guide

1. Cylinder head bolting	Page 4
2. How they work	Page 6
3. Types of bolts	Page 8
4. Tightening procedure	Page 10
5. Professional repairs	Page 13
6. Testing the quality	Page 14
7. Technical details	Page 16
8. Packaging	Page 17

## 1. Cylinder head bolting

### *Fascinating reliability.*

Cylinder head bolting without the need for retightening is standard for modern engine design. There are technical and economic reasons for this, both when manufacturing and repairing engines:

- uniformly high clamp force on all bolts
- reliable, functioning sealing system
- cost savings

To ensure reliable cylinder head bolting while at the same time no need for retightening, all parts involved in the cylinder head sealing system must be finely tuned to each other already in the developmental stage.

Both the design and the material quality of the cylinder-head bolt contribute significantly to the reliability of the sealing system.

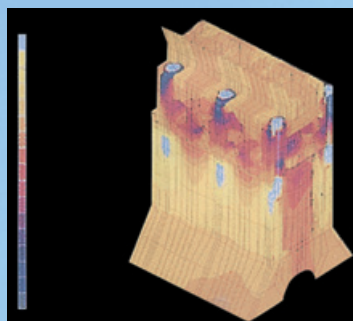

*Tensile and compression stress in the cylinder-head sealing system – visualized using the Finite Element Method*





The cylinder head  
sealing system

Cylinder-head bolts

Cylinder head

Cylinder-head gasket

Crankcase

Liner (depending on  
the engine design)

2. How they work



## Effective forces.

Cylinder-head bolts are the design elements of the cylinder head sealing system that generate the required surface pressure, transmitting it to the engine components. This requires that the cylinder-head bolts be tightened in close compliance with the specified instructions and in the specified sequence (see section 4).

Only the total force available to the cylinder-head gasket can be distributed by the gasket to the various areas to be sealed (gas, water and oil seal). We refer to this as the specific sealing compression distribution.

### Therefore:

The overall clamp force generated by the cylinder-head bolts and its uniform distribution across the entire sealing system is a major prerequisite for the function of the cylinder-head gasket.

Modern lightweight engine designs have demanding requirements, such as

- higher ignition pressures (up to 220 bar)
- increasing relative motion of the engine components
- decreasing engine rigidity and greater thermal component elongation due to the aluminum/magnesium construction
- reduction of distortion of cylinder bores and cylinder head (keyword: reduced bolt forces).

In order to meet these requirements, the cylinder-head bolt has also undergone significant changes in the last several decades of engine engineering. Its properties must fulfill the specific requirements of the engine in detail.

In addition to the improved materials and manufacturing processes for the bolts, the most significant modifications have been made

- in the bolt design (see section 3)
- and
- in the tightening procedure (see section 4).

The surface coatings of the bolts have also been modified to provide more favorable friction conditions.

### 3. Types of bolts



a) Thread rolling bolts with short thread



b) Thread rolling bolt with long thread



c) Helix bolt



d) Anti-fatigue shaft bolt

**The new types of cylinder-head bolts: first choice for lightweight engines.**

The thermal expansion of lightweight engine designs such as

- aluminum cylinder head and gray cast iron crankcase
  - cylinder head and crankcase of aluminum
- is different than that of the steel cylinder-head bolt. The thermal expansion of the aluminum engine components is roughly twice that of the cylinder-head bolts.



The use of lightweight materials for engine parts and the modified tightening procedure (see section 4) are the reasons why primarily the following bolt designs are used for cylinder head bolting on modern engine designs.

**Thread rolling bolts.**

Used mainly for car engines. Thread rolling bolts have a rolled thread on the shaft. The bolt then does not require machining. The elasticity properties of the thread rolling bolt with long thread are very similar to those of the anti-fatigue shaft bolt, which requires machining. That is why this is referred to as an inexpensive type of anti-fatigue shaft bolt.

**a) Thread rolling bolts with short thread.**

The thread is rolled onto these bolts only up to the maximum length of thread engagement. The top turn takes on the greatest amount of force and therefore usually undergoes a permanent plastic deformation.

**b) Thread rolling bolts with long thread.**

These bolts have a very long threaded section that usually extends to just under the bolt head. This is where the elastic and plastic elongation of the bolt occurs during tightening and when the engine is in operation. The design with the long thread increases the elasticity, pro-

vides uniform tension along the shaft and gives the bolt sufficient capacity for plastic deformation, ensuring the durability of the entire cylinder head sealing system.

**c) Helix bolts.**

Helix bolts are bolts onto which a coarse single or multiple thread is rolled as a helix. The helix increases the elasticity on this bolt also, ensuring a uniform distribution of tension. The elastic resilience of the helix bolt depends on the core diameter of the selected helix profile – the smaller the diameter, the more similar the bolt characteristics are to an anti-fatigue shaft bolt.

**d) Anti-fatigue shaft bolts.**

This bolt design is often used for engines on commercial vehicles and is characterized by a tapered shaft extending from the thread to just below the bolt head. Because of the smaller cross section compared to the full shaft bolts, greater elastic and plastic resilience is achieved. The plastic elongation that is important for repairs occurs in the tapered shaft section of the bolt without thread engagement.

## 4. Tightening procedure

### Taking a turn for more reliability.

In collaboration with engine manufacturers and the supplier industry, extensive testing and development programs have been carried out to significantly improve sealing joints with better engine components and techniques such as

- "Metaloflex®" cylinder-head gaskets with high compression potential and low settling behavior
- cylinder-head bolts with special plastic deformation characteristics (see section 3)
- new tightening procedure for cylinder-head bolts (see section 4.2 and 4.3)

These components ensure a reliable seal, especially for long-term performance.

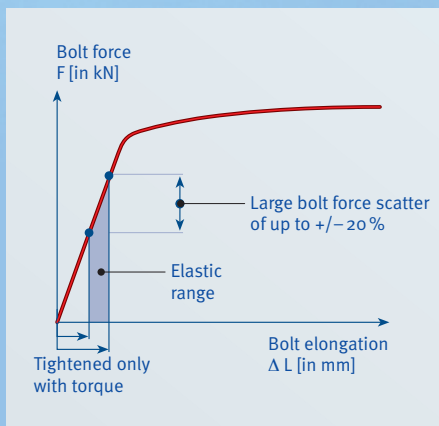

Elastic tightening of bolts

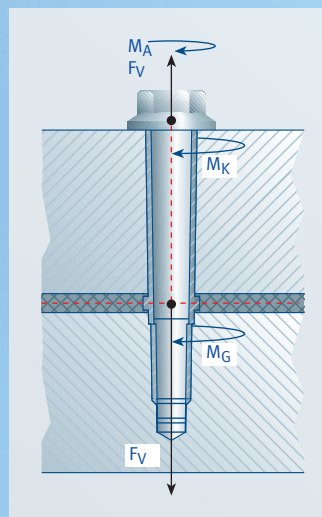

Forces and torque values when tightening

### 4.1. Tightening of bolts with torque.

Cylinder-head bolts used to be tightened with a precisely defined torque in several stages within the elastic elongation range of the bolt material (chart – bottom left).

**Disadvantages of torque-controlled tightening:**

1. When applying the tightening torque  $M_A$ , bolt force deviations of the clamp force  $F_V$  of  $\pm 20\%$  arise due to the different friction torques for the head ( $M_K$ ) and thread ( $M_G$ ) – see figure at bottom right. It was not possible to achieve a uniform distribution of the compression across the entire sealing system using this procedure.

2. As a result of the cold-static settling processes of the soft material gasket after installation (=loss of clamp force) and a further loss of force when the engine is operating, the bolts had to be retightened after the engine had run a specified mileage. But with the retightening of the cylinder-head bolts, the scatter of the bolt forces was by no means eliminated.



*Tightening cylinder-head bolts using rotational angle disc*

## 4.2. Bolt tightening using torque and rotational angle on the new generations of engines.

In this process, the cylinder-head bolt undergoes not only elastic elongation but also plastic elongation. This provides significant advantages in comparison to the tightening of bolts with torque.

### Description of the combined procedure.

In the torque/angle-controlled tightening process, the bolt is tightened in the first stage with a defined low torque in the elastic range of the bolt characteristic curve (chart below).

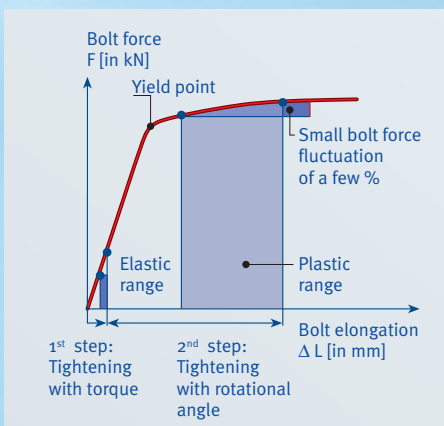

*Plastic tightening of bolts*

At the end of the torque-controlled tightening, the bolt is tightened further by a specified rotational angle. This deforms the bolt material plastically beyond the yield point (which denotes the transition from the elastic to the plastic range).

### Advantages of the rotational angle tightening:

1. In conjunction with the new bolt designs, this tightening method can significantly reduce the fluctuation of the bolt clamp forces. The application of the rotational angle does not result in greater clamp force but rather only in plastic elongation of the bolt, thus ensuring that the bolt force level is consistently high for all cylinder-head bolts. This is an important prerequisite for an overall leak-free sealing system.

2. It is no longer necessary to retighten the cylinder-head bolts. This is made possible in part thanks to the metal-layer gaskets, which settle only slightly. The remaining bolt force fluctuation can be traced back to the dimensional production tolerances for the bolts and strength tolerances for the materials.

## 4. Tightening procedure

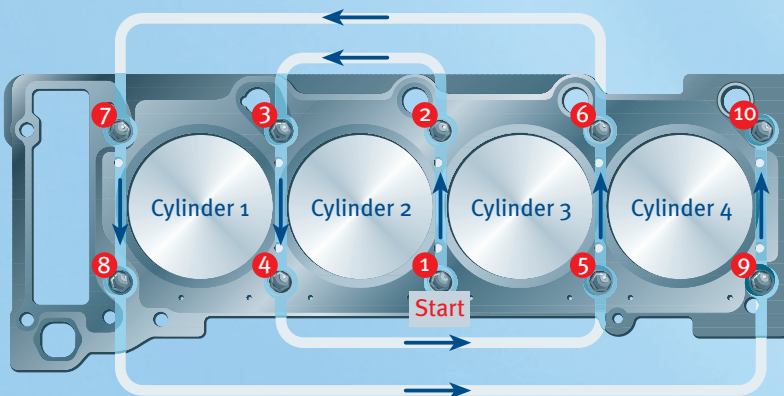

Tightening sequence for cylinder head (example)

### 4.3. Tightening sequence.

The cylinder-head bolts (e.g. 1- 10 on a 4 cylinder engine, illustrated above) are to be tightened in a precisely defined sequence (see manufacturer's instructions). Like tightening torque and tightening angle, this sequence is specified by the engine and gasket manufacturers and depends on the individual engine design. Information for specific engines in several languages – for instance tightening instructions – is included with each cylinder-head gasket and every set of gaskets from Elring.

The bolts are tightened in several steps, for instance:

- 1<sup>st</sup> step 20 Nm (i.e. tighten bolts 1 – 10 with tightening torque of 20 Nm)
- 2<sup>nd</sup> step 60 Nm (i.e. tighten bolts 1 – 10 with tightening torque of 60 Nm)
- 3<sup>rd</sup> step 90° (i.e. tighten bolts 1 – 10 with a rotational angle of 90°)
- 4<sup>th</sup> step 90° (i.e. tighten bolts 1 – 10 with a rotational angle of 90° once again).

Each tightening sequence is based upon the following rule:

Each bolt tightening procedure always begins in the middle of the engine (between cylinder 2 and cylinder 3 – see example), moving in a spiral or crosswise direction outwards along both sides until the outer bolts on cylinder 1 and cylinder 4 have been tightened.

This ensures that the cylinder head and the cylinder-head gasket is clamped optimally to the crankcase.

If the specifications are not followed, undesirable irregular tension and distortion of the engine components can arise.

The consequence: Leaks can occur in the cylinder head sealing system.

## 5. Professional repairs

**Only new cylinder-head bolts provide 100% reliability.**

The new generations of engines have better sealing systems finely tuned to the engine design. And in these systems, the cylinder-head bolts play a major role (see section 1 – 4).

Cylinder-head bolts can be plastically elongated by several millimeters over the original state thanks to

- the new tightening procedure using torque plus rotational angle (= plastic elongation of the bolt) as well as
- the modern engine designs, e.g. aluminum-aluminum pairing (= additional plastic elongation the first time the engine heats up in operation).

The elongation of the bolt not only brings about changes in the strength and elongation properties of the bolt material but also reduces the bolt cross section. If this bolt is used again, there is the danger that the ensuing bolt force can no longer be sustained by the smaller cross section. As a result, the bolt breaks.

Studies have shown that on an M10 bolt of medium strength 10.9, the load capacity can drop by 10 – 15% with a decrease in diameter of just 0.3 mm. The gasket is then compressed with



*Plastically elongated and tapered cylinder-head bolt*

insufficient force and can begin to leak in a short period of time. So for the professional repairing of the cylinder head sealing system, engine and gasket manufacturers specify the following:

- Use only new cylinder-head bolts and a new cylinder-head gasket.
- Observe tightening torque and tightening rotational angle.
- Follow the specified sequence for tightening.
- Make certain that all engine parts are clean and free of distortion.
- Ensure that the installation is done only by trained specialists.
- Use high-quality tools.

Optimum clamping and a good seal are possible only if these specifications are followed. Bolts that have already been used once and have undergone plastic elongation may not be used. In this way, unpleasant consequences such as leakage and the resulting repair costs, annoyed customers and image loss can be prevented.

## 6. Testing the quality

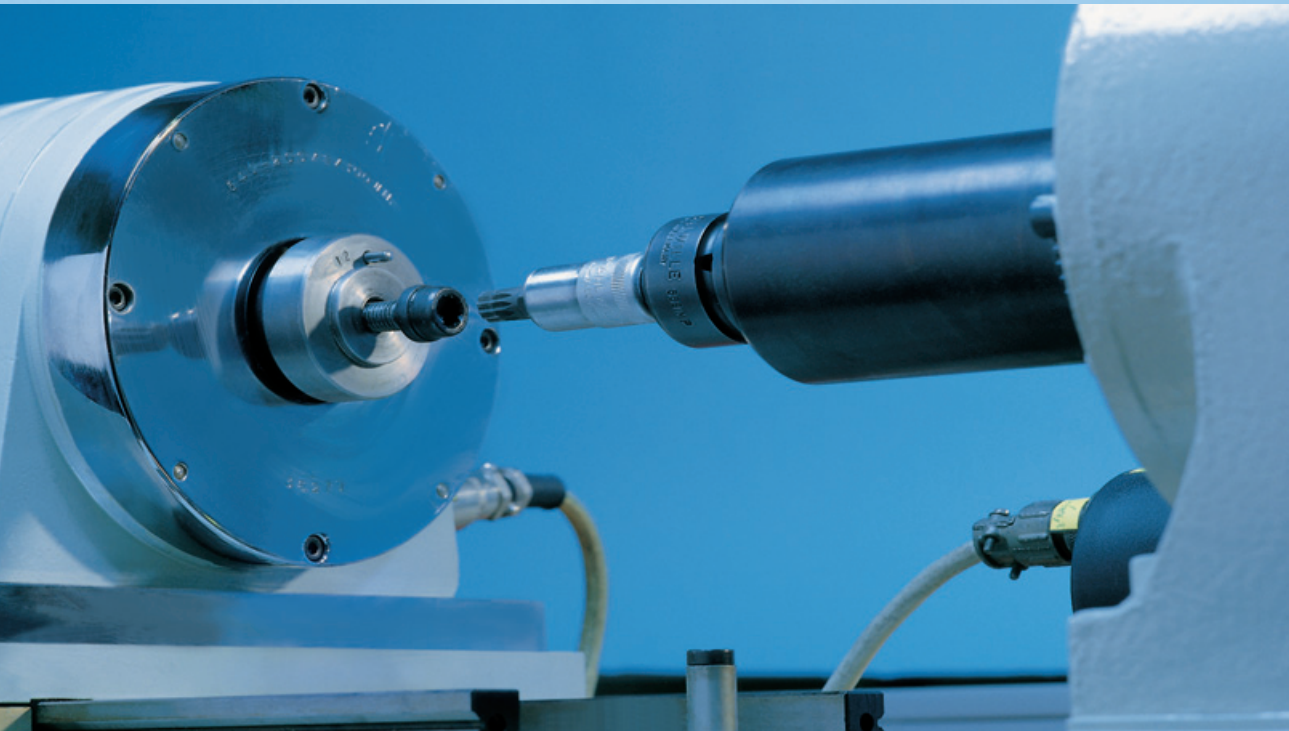

*Bolt test bench – the reliable test to determine the characteristic bolt curve*

### **T***ested reliability.*

Every engine model places certain demands on cylinder-head bolts that must be fulfilled to ensure that the entire sealing system functions properly.

For that reason, drawings, test reports regarding initial samples and various chemical and dimensional protocols for each bolt type are examined closely.

Before a bolt type is approved, measurements are taken regularly on a bolt test bench, ensuring that quality standards are fulfilled.

## Generation of a characteristic bolt curve on the bolt test bench.

In the test, the bolt is tightened beyond the level specified in the tightening procedure (in this case, torque 60 Nm + rotational angle 180°) to get a detailed and representative characteristic bolt curve. The characteristic curve recorded during the tightening process is assessed according to the following criteria (1 – 4):

1. The bolt force  $F_1$  reached after tightening with the specified torque and rotational angle (in this case 60 Nm + 180°) must lie within a defined force range between the minimum and maximum force (10 N ~ 1 kg).

2. After a specific torque (in this case 70 Nm) has been applied, the bolt must be turned at least another two rotations ( $\pm 90^\circ$  rotational angle, depending on manufacturer). This may not result in a significant decrease in bolt force.

3. The difference between the measured maximum force  $F_{max}$  and the force after tightening  $F_1$  must be greater than the value specified by the manufacturer (in this case 4000 N).

4. The characteristic bolt curve (red-yellow) must follow the curve depicted here when tightened. It may not show any leaps or other deviations.

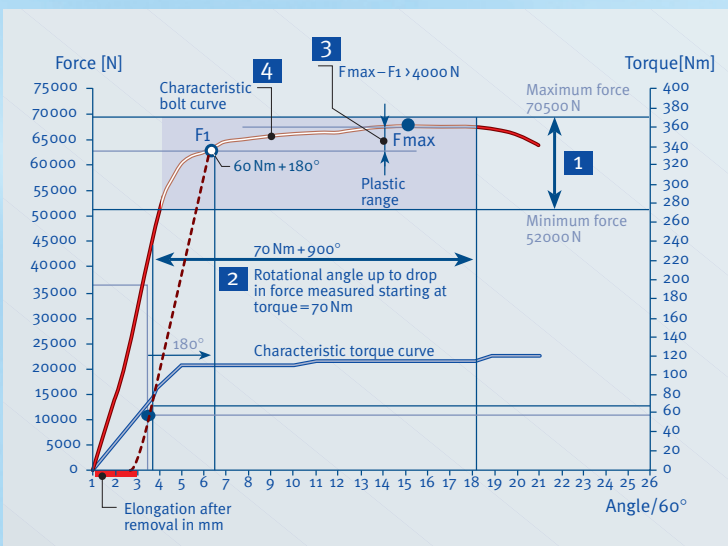

Characteristic bolt curve

The fulfillment of these four vital criteria on the bolt test bench as well as the accompanying dimension and chemical consistency reports ensure that the bolt type tested has the potential to reliably seal the engine.

To round off the chart of the characteristic curve, the permanent elongation of the bolt after removal from the test bench is depicted in the lower left hand corner. When the bolt is loosened, the characteristic curve moves from the value  $F_1$  along the red dotted line downwards. The red section corresponds to the permanent elongation of the bolt after removal.

## 7. Technical details

### Example:

**M10 x 140 x 1.5 internal hexagon 10.9**

Nominal diameter (in mm)  
e.g. M10, M11, M12, M16

Nominal length (in mm)

Thread pitch (in mm)  
i.e. the length of thread en-  
gagement after one turn  
of the bolt (in mm), e.g. 1;  
1.25; 1.5; 1.75; 2

Thread profile  
Metric ISO thread  
Special designs:  
Fine thread, saw thread,  
Whitworth thread

Strength class

for example	8.8	10.9	12.9
	=	=	=
Tensile strength in N/mm <sup>2</sup>	800	1000	1200
Yield point in N/mm <sup>2</sup>	640	900	1080

Head shape (= also referred to as "drive")

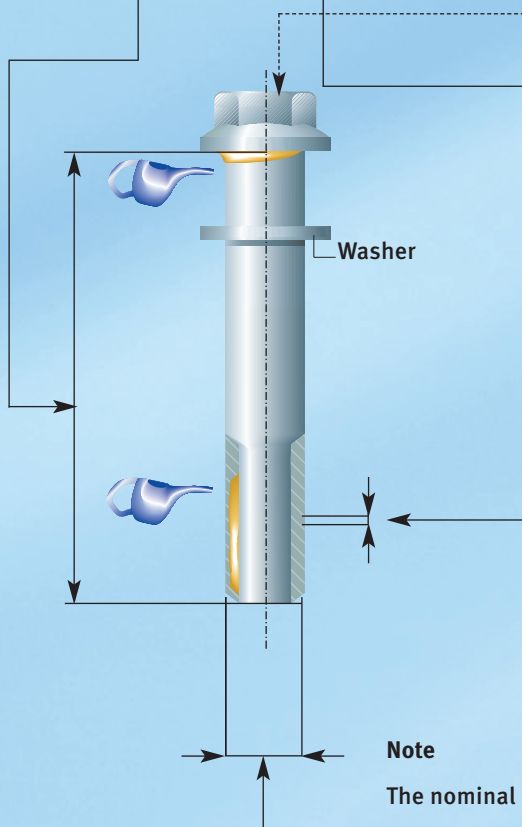
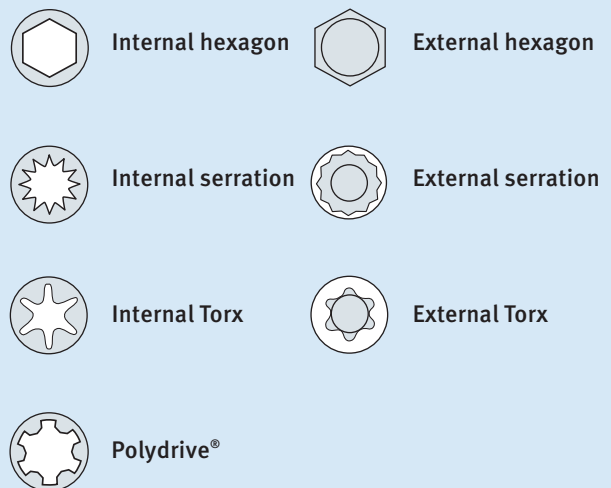

#### Note

The nominal length is always measured up to the seating surface under the bolt head, even if a washer is to be used.



#### Installation tip

Before installation, the seating surface of the bolt head and the thread should be oiled so that the friction factors are not too high and the required bolt clamp force is achieved.



## 8. Packaging

### *Cylinder-head bolts – packed securely.*

For us, it is especially important that our cylinder-head bolts are packed securely so they reach our customers in the tested quality and free of damage. For that reason, the right cylinder-head bolts are selected for the engine and then packaged in environmentally-friendly collapsible boxes. And thanks to individual box inserts, it is possible to pack about 95 % of the over 200 bolt types with all their lengths and diameters in just one box size, greatly simplifying storage.



This packaging solution offers top protection and simplifies logistics while ensuring that the bolts maintain their required functionality, thus fulfilling our customers' expectations.

Ensuring that our customers are supplied with identical product quality and top service throughout the world is an integral part of our corporate policy – and the basis for long term and constructive cooperation with our customers.

The information provided in this brochure, based upon many years' experience and knowledge, does not claim completeness. No liability is assumed for damage claims on the basis of this information. All parts must be installed by trained and specialized staff. Product range and technical specifications subject to modification. No liability assumed for errata.



Das Original

ElringKlinger AG | Aftermarket Division  
Max-Eyth-Straße 2 | D-72581 Dettingen/Erms  
Phone +49 71 23/724-601 | Fax +49 71 23/724-609  
Phone +49 71 23/724-626 | Fax +49 71 23/724-629 / Europe  
Phone +49 71 23/724-650 | Fax +49 71 23/724-659 / overseas  
service@elring.de | www.elring.de