

Engine Workshop Manual SKYACTIV-G 2.0

FOREWORD

This manual explains the service points for the above-indicated automotive system. This manual covers all models with the above-indicated automotive system, not any one specific model.

In order to do these procedures safely, quickly, and correctly, you must first read this manual and any other relevant service materials carefully.

All the contents of this manual, including drawings and specifications, are the latest available at the time of printing. As modifications affecting repair or maintenance occur, relevant information supplementary to this volume will be made available at Mazda dealers. This manual should be kept up-to-date.

Mazda Motor Corporation reserves the right to alter the specifications and contents of this manual without obligation or advance notice.

All rights reserved. No part of this book may be reproduced or used in any form or by any means, electronic or mechanical—including photocopying and recording and the use of any kind of information storage and retrieval system—without permission in writing.

Mazda Motor Corporation
HIROSHIMA, JAPAN

CONTENTS

Title	Section
GENERAL INFORMATION	00
ENGINE	01

© 2011 Mazda Motor Corporation
PRINTED IN U.S.A., DECEMBER 2011
Form No. 1A08-1U-11L
Part No. 9999-95-EWPE-12

WARNING

Servicing a vehicle can be dangerous. If you have not received service-related training, the risks of injury, property damage, and failure of servicing increase. The recommended servicing procedures for the vehicle in this workshop manual were developed with Mazda-trained technicians in mind. This manual may be useful to non-Mazda trained technicians, but a technician with our service-related training and experience will be at less risk when performing service operations. However, all users of this manual are expected to at least know general safety procedures.

This manual contains "Warnings" and "Cautions" applicable to risks not normally encountered in a general technician's experience. They should be followed to reduce the risk of injury and the risk that improper service or repair may damage the vehicle or render it unsafe. It is also important to understand that the "Warnings" and "Cautions" are not exhaustive. It is impossible to warn of all the hazardous consequences that might result from failure to follow the procedures.

The procedures recommended and described in this manual are effective methods of performing service and repair. Some require tools specifically designed for a specific purpose. Persons using procedures and tools which are not recommended by Mazda Motor Corporation must satisfy themselves thoroughly that neither personal safety nor safety of the vehicle will be jeopardized.

The contents of this manual, including drawings and specifications, are the latest available at the time of printing, and Mazda Motor Corporation reserves the right to change the vehicle designs and alter the contents of this manual without notice and without incurring obligation.

Parts should be replaced with genuine Mazda replacement parts or with parts which match the quality of genuine Mazda replacement parts. Persons using replacement parts of lesser quality than that of genuine Mazda replacement parts must satisfy themselves thoroughly that neither personal safety nor safety of the vehicle will be jeopardized.

Mazda Motor Corporation is not responsible for any problems which may arise from the use of this manual. The cause of such problems includes but is not limited to insufficient service-related training, use of improper tools, use of replacement parts of lesser quality than that of genuine Mazda replacement parts, or not being aware of any revision of this manual.

GENERAL INFORMATION

00
SECTION

00-00

GENERAL INFORMATION 00-00

00-00 GENERAL INFORMATION

HOW TO USE THIS MANUAL	00-00-2	Preparation of Tools and Measuring	
Range of Topics	00-00-2	Equipment	00-00-6
Service Procedure	00-00-2	Special Service Tools	00-00-6
Symbols	00-00-4	Disassembly	00-00-6
Advisory Messages	00-00-4	Inspection During Removal,	
UNITS	00-00-5	Disassembly	00-00-7
Conversion From SI Units		Arrangement of Parts	00-00-7
(Système International d'Unités)	00-00-5	Cleaning of Parts	00-00-7
Number Of Digits For		Reassembly	00-00-8
Converted Values	00-00-5	Adjustment	00-00-8
Converted Value Rounding Off And		Rubber Parts and Tubing	00-00-8
Rounding Up/down	00-00-5	Torque Formulas	00-00-9
ABBREVIATIONS	00-00-6	Vise	00-00-9
FUNDAMENTAL PROCEDURES	00-00-6		

cardiagn.com

GENERAL INFORMATION

HOW TO USE THIS MANUAL

id000000000100

Range of Topics

- This manual contains procedures for performing all required service operations. The procedures are divided into the following basic operations:
 - Removal/Installation
 - Disassembly/Assembly
 - Replacement
 - Inspection
 - Adjustment
- Simple operations which can be performed easily just by looking at the actual unit (i.e., removal/installation of parts, cleaning of parts, and visual inspection) have been omitted.

Service Procedure

Inspection, adjustment

- Inspection and adjustment procedures are divided into steps. Important points regarding the location and contents of the procedures are explained in detail and shown in the illustrations.

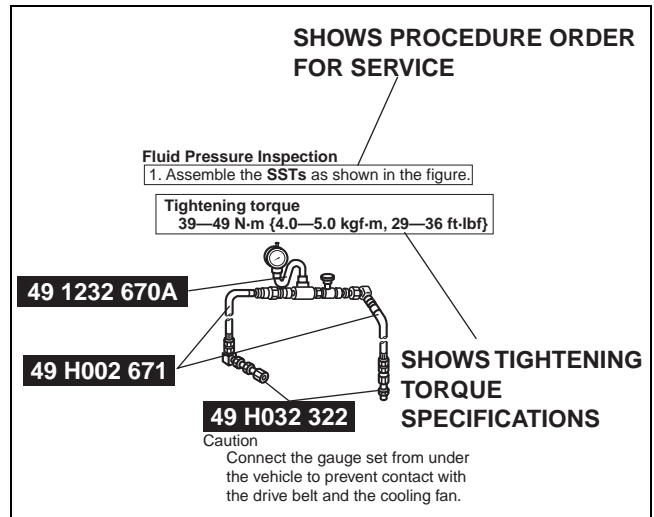

bpe2ue00000101

cardiagn.com

GENERAL INFORMATION

00-00

Repair procedure

1. Most repair operations begin with an overview illustration. It identifies the components, shows how the parts fit together, and describes visual part inspection. However, only removal/installation procedures that need to be performed methodically have written instructions.
2. Expendable parts, tightening torques, and symbols for oil, grease, and sealant are shown in the overview illustration. In addition, symbols indicating parts requiring the use of special service tools or equivalent are also shown.
3. Procedure steps are numbered and the part that is the main point of that procedure is shown in the illustration with the corresponding number. Occasionally, there are important points or additional information concerning a procedure. Refer to this information when servicing the related part.

Procedure

"Removal/Installation" Portion

"Inspection After Installation" Portion

INSTALL THE PARTS BY PERFORMING STEPS 1—3 IN REVERSE ORDER

SHOWS SERVICE ITEM (S)

INDICATES ANY RELEVANT REFERENCES WHICH NEED TO BE FOLLOWED DURING INSTALLATION

SHOWS SPECIAL SERVICE TOOL (SST) FOR SERVICE OPERATION

SHOWS APPLICATION POINTS OF GREASE, ETC.

SHOWS NON-REUSEABLE PARTS

SHOWS DETAILS

SHOWS TIGHTENING TORQUE UNITS

SHOWS THERE ARE REFERRAL NOTES FOR SERVICE

SHOWS REFERRAL NOTES FOR SERVICE

LOWER TRAILING LINK, UPPER TRAILING LINK REMOVAL/INSTALLATION

1. Jack up the rear of the vehicle and support it with safety stands.
2. Remove the undercover. (See 01-10-4 Undercover Removal)
3. Remove in the order indicated in the table.
4. Install in the reverse order of removal.
5. Inspect the rear wheel alignment and adjust it if necessary.

1	Split pin
2	Nut
3	Lower trailing link ball joint (See 02-14-5 Lower Trailing Link Ball Joint Removal Note)
4	Bolt
5	Lower trailing link
6	Dust boot (lower trailing link)

7	Split pin
8	Nut
9	Upper trailing link ball joint (See 02-14-5 Upper Trailing Link Ball Joint Removal Note)
10	Nut
11	Upper trailing link
12	Dust boot (upper trailing link)

Lower Trailing Link Ball Joint, Upper Trailing Link Ball Joint Removal Note

- Remove the ball joint using the SSTs.

SHOWS SPECIAL SERVICE TOOL (SST) NO.

49 T028 304 UPPER TRAILING LINK
49 T028 305 LOWER TRAILING LINK

49 T028 303









KNUCKLE

bpe2ue0000001

GENERAL INFORMATION

Symbols

- There are eight symbols indicating oil, grease, fluids, sealant, and the use of **SST** or equivalent. These symbols show application points or use of these materials during service.

Symbol	Meaning	Kind
	Apply oil	New appropriate engine oil or gear oil
	Apply brake fluid	New appropriate brake fluid
	Apply automatic transaxle/ transmission fluid	New appropriate automatic transaxle/ transmission fluid
	Apply grease	Appropriate grease
	Apply sealant	Appropriate sealant
	Apply petroleum jelly	Appropriate petroleum jelly
	Replace part	O-ring, gasket, etc.
	Use SST or equivalent	Appropriate tools

Advisory Messages

- You will find several **Warnings, Cautions, Notes, Specifications** and **Upper and Lower Limits** in this manual.

Warning

- A Warning indicates a situation in which serious injury or death could result if the warning is ignored.

Caution

- A Caution indicates a situation in which damage to the vehicle or parts could result if the caution is ignored.

Note

- A Note provides added information that will help you to complete a particular procedure.

Specification

- The values indicate the allowable range when performing inspections or adjustments.

Upper and lower limits

- The values indicate the upper and lower limits that must not be exceeded when performing inspections or adjustments.

GENERAL INFORMATION

UNITS

id000000100400

Electric current	A (ampere)
Electric power	W (watt)
Electric resistance	ohm
Electric voltage	V (volt)
Length	mm (millimeter)
	in (inch)
Negative pressure	kPa (kilo pascal)
	mmHg (millimeters of mercury)
	inHg (inches of mercury)
Positive pressure	kPa (kilo pascal)
	kgf/cm ² (kilogram force per square centimeter)
	psi (pounds per square inch)
Number of revolutions	rpm (revolutions per minute)
Torque	N·m (Newton meter)
	kgf·m (kilogram force meter)
	kgf·cm (kilogram force centimeter)
	ft·lbf (foot pound force)
	in·lbf (inch pound force)
Volume	L (liter)
	US qt (U.S. quart)
	Imp qt (Imperial quart)
	ml (milliliter)
	cc (cubic centimeter)
	cu in (cubic inch)
	fl oz (fluid ounce)
Weight	g (gram)
	oz (ounce)

00-00

Conversion From SI Units (Système International d'Unités)

- All numerical values in this manual are based on SI units. Numbers shown in conventional units are converted from these values.

Number Of Digits For Converted Values

- The number digits for converted values is the same as the number of significant figures*¹ of the SI unit.
- For the torque value, the number of significant figures is, in principle, is 2 digits, in consideration of market practicalities. However, if the number of decimal places at the upper and lower limits of the converted value differs, the one with least number of decimal places is used. In addition, if the integer part is 3 digits or more, the integer part becomes the significant number of figures.

*1 : The number of significant figures is the number of digits from the left-most non-zero digit to the right-most digit including 0. (Example: 0.12 is 2 digits, 41.0 is 3 digits)

Converted Value Rounding Off And Rounding Up/down

- If there is no tolerance in the SI unit value, after conversion, rounding off is to within the number of significant digits.
- If there is tolerance in the SI unit value and the figure after conversion indicates the upper limit, the number of digits is rounded down to within the number of significant figures. If it indicates the lower limit, they are rounded up to within the number of significant figures.
- Even if the SI unit value is the same, the converted value may differ based on whether that value is the upper or lower limit.

GENERAL INFORMATION

ABBREVIATIONS

id000000010100

ATX	Automatic Transaxle
EX	Exhaust
HLA	Hydraulic Lash Adjuster
IN	Intake
MTX	Manual Transaxle
OCV	Oil Control Valve
TDC	Top Dead Center
SST	Special Service Tool

FUNDAMENTAL PROCEDURES

id000000750100

Preparation of Tools and Measuring Equipment

- Be sure that all necessary tools and measuring equipment are available before starting any work.

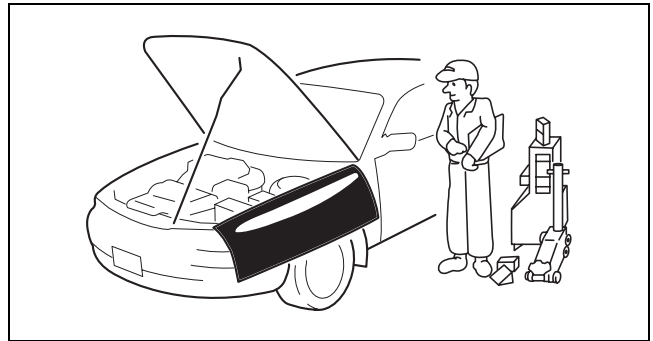

bpe2ue00000110

Special Service Tools

- Use special service tools or equivalent when they are required.

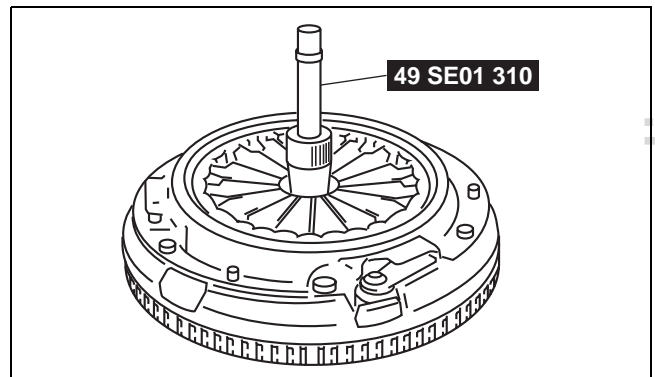

bpe2ue00000111

Disassembly

- If the disassembly procedure is complex, requiring many parts to be disassembled, all parts should be marked in a place that will not affect their performance or external appearance and identified so that reassembly can be performed easily and efficiently.

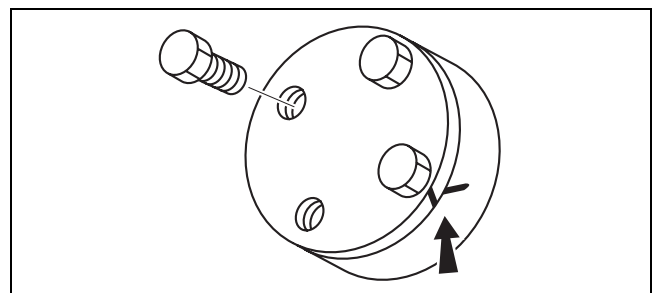

bpe2ue00000112

GENERAL INFORMATION

Inspection During Removal, Disassembly

- When removed, each part should be carefully inspected for malfunction, deformation, damage and other problems.

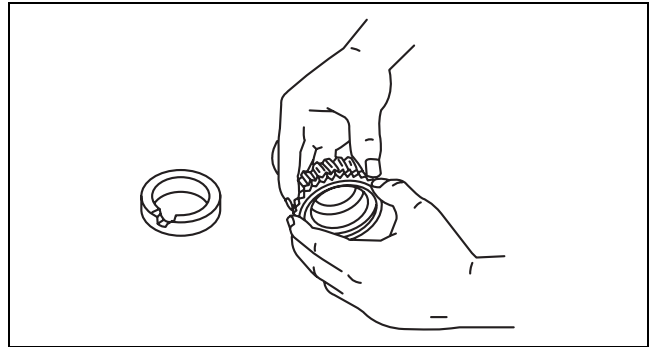

bpe2ue00000113

00-00

Arrangement of Parts

- All disassembled parts should be carefully arranged for reassembly.
- Be sure to separate or otherwise identify the parts to be replaced from those that will be reused.

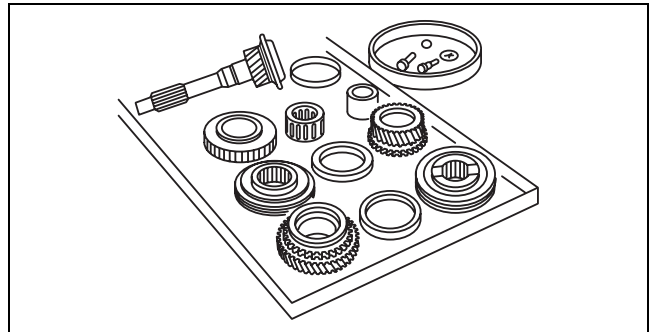

bpe2ue00000114

Cleaning of Parts

- All parts to be reused should be carefully and thoroughly cleaned in the appropriate method.

Warning

- **Using compressed air can cause dirt and other particles to fly out causing injury to the eyes. Wear protective eye wear whenever using compressed air.**

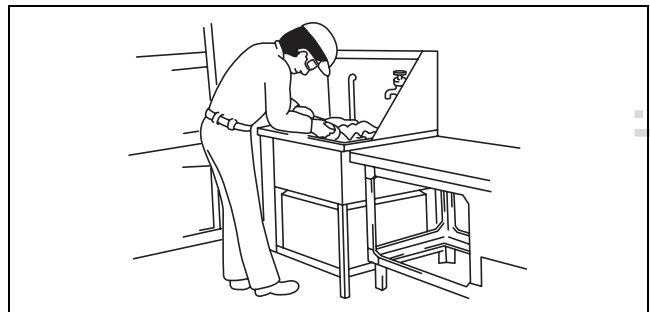

bpe2ue00000002

GENERAL INFORMATION

Reassembly

- Standard values, such as torques and certain adjustments, must be strictly observed in the reassembly of all parts.
- If removed, the following parts should be replaced with new ones:
 - Oil seals
 - Gaskets
 - O-rings
 - Lockwashers
 - Cotter pins
 - Nylon nuts
- Depending on location:
 - Sealant and gaskets, or both, should be applied to specified locations. When sealant is applied, parts should be installed before sealant hardens to prevent leakage.
 - Oil should be applied to the moving components of parts.
 - Specified oil or grease should be applied at the prescribed locations (such as oil seals) before reassembly.

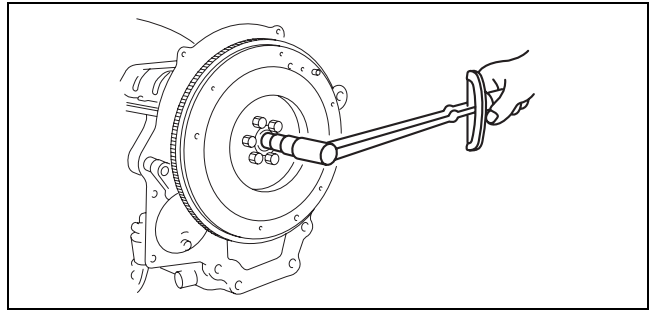

bpe2ue00000115

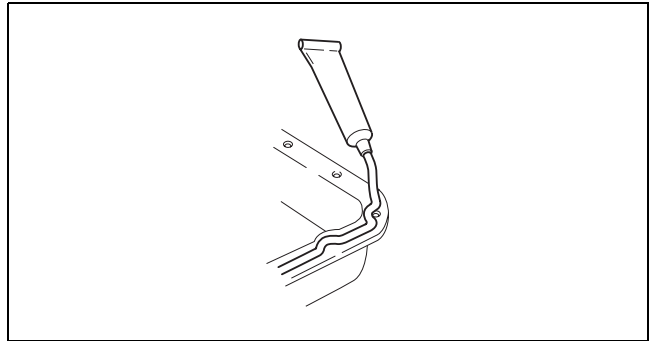

bpe2ue00000116

Adjustment

- Use suitable gauges and testers when making adjustments.

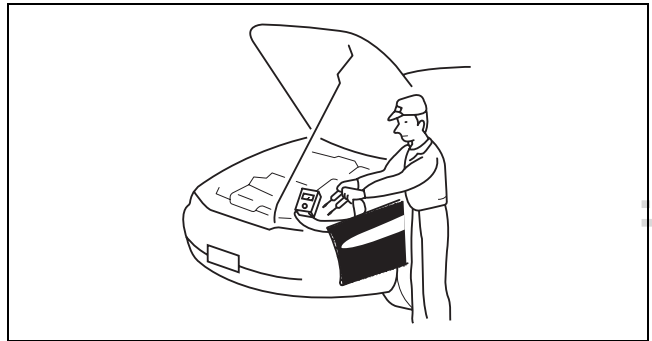

bpe2ue00000117

Rubber Parts and Tubing

- Prevent gasoline or oil from getting on rubber parts or tubing.

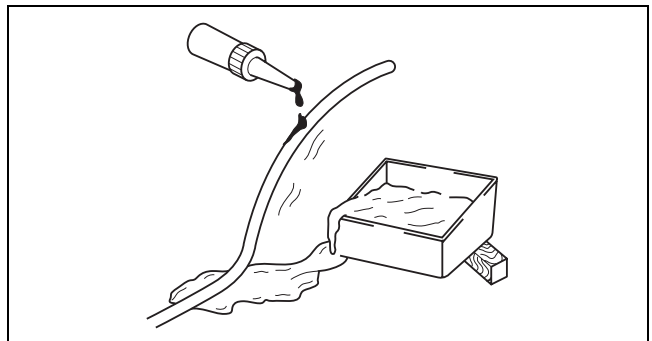

bpe2ue00000118

GENERAL INFORMATION

Torque Formulas

- When using a torque wrench-**SST** or equivalent combination, the written torque must be recalculated due to the extra length that the **SST** or equivalent adds to the torque wrench. Recalculate the torque by using the following formulas. Choose the formula that applies to you.

Torque Unit	Formula
N·m	$N \cdot m \times [L/(L+A)]$
kgf·m	$kgf \cdot m \times [L/(L+A)]$
kgf·cm	$kgf \cdot cm \times [L/(L+A)]$
ft·lbf	$ft \cdot lbf \times [L/(L+A)]$
in·lbf	$in \cdot lbf \times [L/(L+A)]$

- A : The length of the **SST** past the torque wrench drive.
L : The length of the torque wrench.

Vise

- When using a vise, put protective plates in the jaws of the vise to prevent damage to parts.

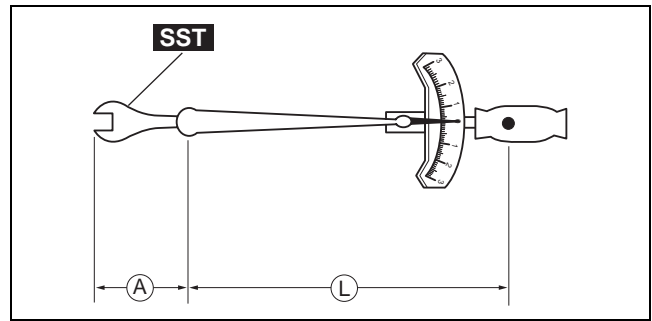

bpe2ue00000119

00-00

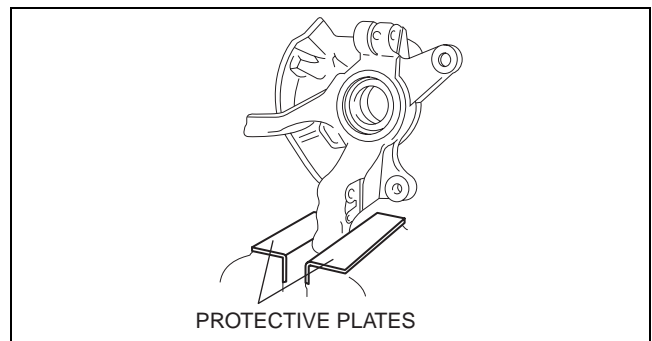

PROTECTIVE PLATES

bpe2ue00000120

cardiagn.com

ENGINE

01
SECTION

01-10

MECHANICAL 01-10
TECHNICAL DATA 01-50

SERVICE TOOLS 01-60

01-10 MECHANICAL

ELECTRIC VARIABLE VALVE TIMING	
MOTOR/DRIVER INSPECTION	01-10-2
HYDRAULIC VARIABLE VALVE TIMING	
ACTUATOR INSPECTION	01-10-3
ELECTRIC VARIABLE VALVE TIMING	
ACTUATOR INSPECTION	01-10-3
OIL CONTROL VALVE (OCV)	
INSPECTION	01-10-4
Coil Resistance Inspection	01-10-4
Spool Valve Operation Inspection	01-10-4
HYDRAULIC LASH ADJUSTER (HLA)	
INSPECTION	01-10-5
ROCKER ARM INSPECTION	01-10-5
ENGINE OVERHAUL	
SERVICE WARNING	01-10-5
ENGINE	
MOUNTING/DISMOUNTING	01-10-5
Mounting	01-10-5
Dismounting	01-10-6
TIMING CHAIN DISASSEMBLY	01-10-7
Water Pump Pulley	
Disassembly Note	01-10-9
Crankshaft Pulley Lock Bolt	
Disassembly Note	01-10-10
Oil Pan Disassembly Note	01-10-10
Engine Front Cover	
Disassembly Note	01-10-10
Front Oil Seal Disassembly Note	01-10-11
Chain Tensioner Removal Note	01-10-11
Oil Pump Driven Sprocket	
Disassembly Note	01-10-12
CYLINDER HEAD	
DISASSEMBLY (I)	01-10-13
Electric Variable Valve Timing Actuator,	
Hydraulic Variable Valve Timing	
Actuator Disassembly Note	01-10-15
Camshaft Cap Disassembly Note	01-10-15
Rocker Arm Disassembly Note	01-10-15
HLA Disassembly Note	01-10-15
Cylinder Head Disassembly Note	01-10-15
CYLINDER HEAD	
DISASSEMBLY (II)	01-10-16
Valve Keeper Disassembly Note	01-10-17
Valve Seal Disassembly Note	01-10-17
CYLINDER BLOCK	
DISASSEMBLY (I)	01-10-18
Flywheel (MTX), Drive Plate (ATX)	
Disassembly Note	01-10-19

Rear Oil Seal Removal Note	01-10-19
CYLINDER BLOCK	
DISASSEMBLY (II)	01-10-20
Pilot Bearing Disassembly Note	01-10-21
Connecting Rod Cap	
Disassembly Note	01-10-21
Connecting Rod Bearing	
Disassembly Note	01-10-21
Piston, Connecting Rod	
Disassembly Note	01-10-21
Snap Ring Disassembly Note	01-10-22
Lower Cylinder Block	
Disassembly Note	01-10-22
Thrust Bearing And Main Bearing	
Disassembly Note	01-10-23
Crankshaft Disassembly Note	01-10-23
CYLINDER HEAD INSPECTION	01-10-23
VALVE SEAT	
INSPECTION/REPAIR	01-10-24
VALVE, VALVE GUIDE	
INSPECTION	01-10-25
VALVE GUIDE REPLACEMENT	01-10-26
Removal	01-10-26
Installation	01-10-27
VALVE SPRING INSPECTION	01-10-27
CAMSHAFT INSPECTION	01-10-28
CYLINDER BLOCK INSPECTION	01-10-30
OIL JET VALVE INSPECTION	01-10-30
PISTON INSPECTION	01-10-30
PISTON RING INSPECTION	01-10-31
PISTON PIN INSPECTION	01-10-32
PISTON AND CONNECTING ROD	
INSPECTION	01-10-33
CONNECTING ROD INSPECTION	01-10-33
CONNECTING ROD CLEARANCE	
INSPECTION	01-10-33
CRANKSHAFT INSPECTION	01-10-34
FLYWHEEL INSPECTION	01-10-35
PILOT BEARING INSPECTION	01-10-36
BOLT INSPECTION	01-10-36
CYLINDER BLOCK ASSEMBLY (I)	01-10-37
Thrust Bearing And Main Bearing	
Assembly Note	01-10-38
Plate Assembly Note	01-10-38
Lower Cylinder Block	
Assembly Note	01-10-39
Piston Pin Assembly Note	01-10-40
Snap Ring Assembly Note	01-10-40

cardiagn.com

MECHANICAL

<p>Piston Ring Assembly Note 01-10-41</p> <p>Connecting Rod Bearing Assembly Note 01-10-41</p> <p>Piston, Connecting Rod Assembly Note 01-10-41</p> <p>Connecting Rod Cap Assembly Note 01-10-42</p> <p>Pilot Bearing Assembly Note 01-10-42</p> <p>CYLINDER BLOCK ASSEMBLY (II) 01-10-43</p> <p>Oil Baffle Plate Assembly Note 01-10-44</p> <p>Oil Pump Assembly Note 01-10-44</p> <p>Water Pump Assembly Note 01-10-45</p> <p>Rear Oil Seal Assembly Note 01-10-46</p> <p>End Plate Assembly Note 01-10-47</p> <p>Flywheel (MTX), Drive Plate (ATX) Assembly Note 01-10-48</p> <p>CYLINDER HEAD ASSEMBLY (I) 01-10-48</p> <p>Valve Seal Assembly Note 01-10-49</p> <p>Valve Spring Assembly Note 01-10-49</p> <p>Valve Keeper Assembly Note 01-10-49</p> <p>Water Outlet Assembly Note 01-10-50</p> <p>Thermostat Assembly Note 01-10-50</p> <p>CYLINDER HEAD ASSEMBLY (II) 01-10-51</p> <p>Cylinder Head Assembly Note 01-10-53</p>	<p>Water Inlet Pipe Assembly Note 01-10-54</p> <p>HLA Assembly Note 01-10-55</p> <p>Rocker Arm Assembly Note 01-10-55</p> <p>Camshaft Assembly Note 01-10-56</p> <p>Electric Variable Valve Timing Actuator, Hydraulic Variable Valve Timing Actuator Assembly Note 01-10-58</p> <p>TIMING CHAIN ASSEMBLY 01-10-59</p> <p>Oil Pump Driven Sprocket Assembly Note 01-10-61</p> <p>Timing Chain Assembly Note 01-10-62</p> <p>Engine Front Cover Assembly Note 01-10-64</p> <p>Oil Pan Assembly Note 01-10-68</p> <p>Electric Variable Valve Timing Motor/Driver Assembly Note 01-10-69</p> <p>Front Oil Seal Assembly Note 01-10-70</p> <p>Crankshaft Pulley Lock Bolt Assembly Note 01-10-71</p> <p>Water Pump Pulley Assembly Note 01-10-72</p> <p>Oil Shower Pipe Installation Note 01-10-73</p> <p>Cylinder Head Cover Installation Note 01-10-73</p>
---	---

ELECTRIC VARIABLE VALVE TIMING MOTOR/DRIVER INSPECTION

id011000828100

Caution

- Do not disassemble the electric variable valve timing motor/driver because it is a precision unit.
- Do not apply excessive force when rotating the electric variable valve timing motor joint. If it is rotated with excessive force, the electric variable valve timing motor could be damaged.

1. Rotate the electric variable valve timing motor joint to the left and right by your fingers and verify that it rotates smoothly in 15° increments.

Note

- Rotate the joint area smoothly using only the tips of your fingers.
- The electric variable valve timing motor joint moves in 15° increments, and if the joint is moved 24 times, it rotates one full rotation.
- If it does not rotate smoothly, replace the electric variable valve timing motor/driver.

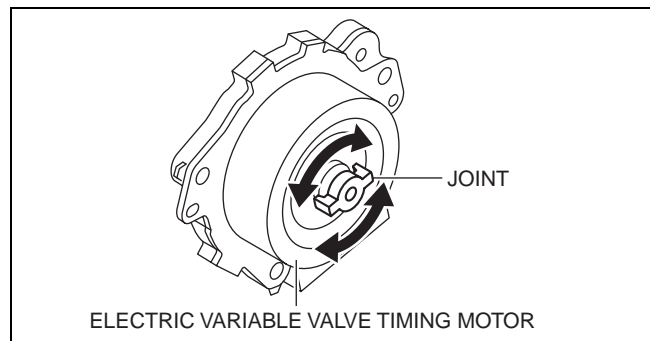

am3uuw00009048

cardiagn.com

HYDRAULIC VARIABLE VALVE TIMING ACTUATOR INSPECTION

id011000126800

Caution

- Do not disassemble the hydraulic variable valve timing actuator because it is a precision unit.

1. Verify that the notch of the rotor and projection of the cover on the hydraulic variable valve timing actuator are aligned and fitted.

- If the projection and notch are not aligned, rotate the rotor (camshaft installation) until a click is heard and verify that they are aligned and fixed in place.
 - If the projection and notch are not aligned or the rotor and cover are not secured even if their projection and notch are aligned, replace the hydraulic variable valve timing actuator.

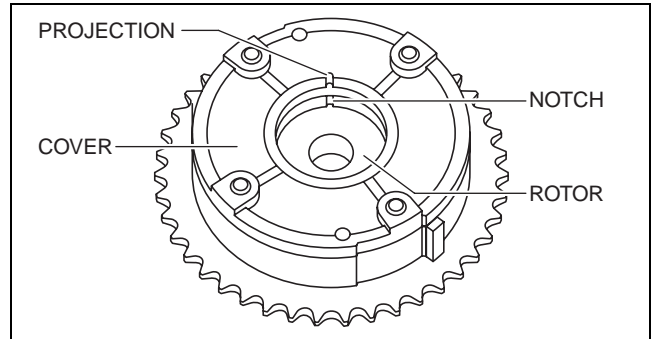

bpe2ue0000012

01-10

ELECTRIC VARIABLE VALVE TIMING ACTUATOR INSPECTION

id011000555500

Caution

- Do not disassemble the electric variable valve timing actuator because it is a precision unit.

1. Rotate the eccentric shaft of the electric variable valve timing actuator to the left and right by hand and verify that it rotates smoothly.

- If it does not rotate smoothly, replace the electric variable valve timing actuator.

Note

- Hook a finger onto the joint groove of the eccentric shaft to rotate the shaft easily.
- The eccentric shaft stops rotating at the maximum retard position when it is rotated counterclockwise as viewed from the front, and at the maximum advance position when rotated clockwise.
- The eccentric shaft rotates 15.8 turns from the maximum retard position to the maximum advance position.

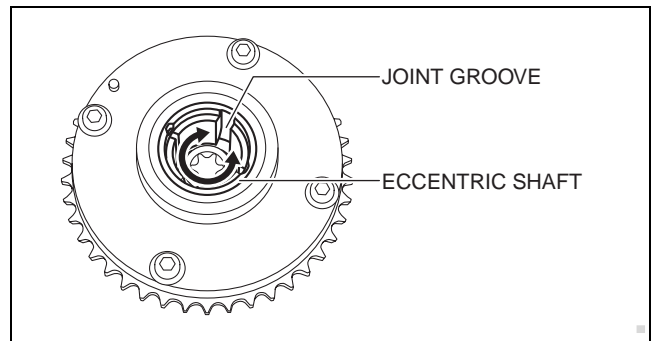

bpe2ue0000097

cardiagn.com

OIL CONTROL VALVE (OCV) INSPECTION

id011000801400

Coil Resistance Inspection

1. Measure the resistance between terminals A and B using an ohmmeter.

OCV coil resistance

6.9—7.5 ohms [20°C {68°F}]

- If it is not within the specification, replace the OCV.

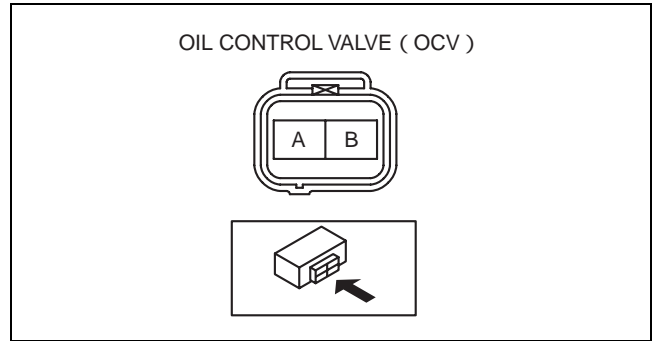

am3uuw00008883

Spool Valve Operation Inspection

1. Verify that the spool valve in the OCV is in the maximum valve timing advance position as indicated in the figure.
 - If there is any malfunction, replace the OCV.

Note

- When applying battery positive voltage between the OCV terminals, the connection can be either of the following:
 - Positive battery cable to terminal A, negative battery cable to terminal B
 - Positive battery cable to terminal B, negative battery cable to terminal A

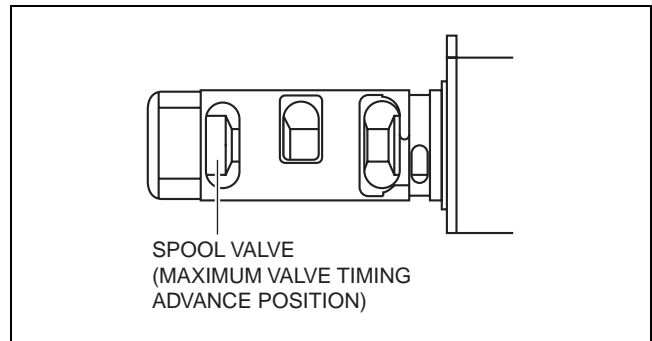

am3uuw00008884

2. Apply battery positive voltage between the OCV terminals and verify that the spool valve operates and moves to the maximum valve timing retard position.

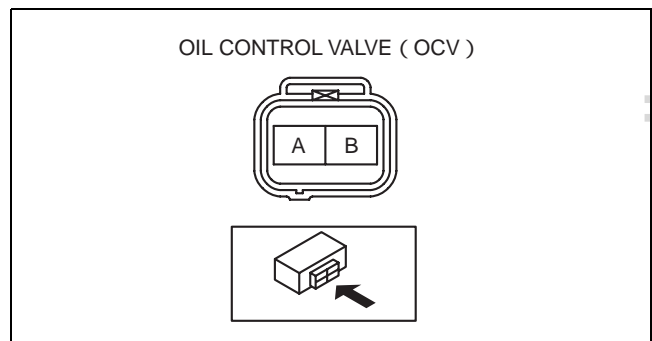

am3uuw00008883

3. Stop applying battery positive voltage and verify that the spool valve returns to the maximum valve timing advance position.
 - If there is any malfunction, replace the OCV.

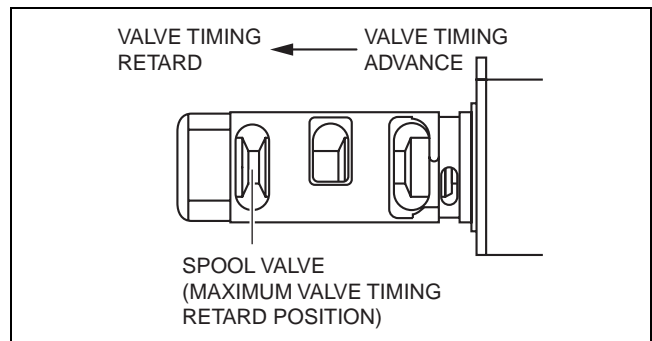

am3uuw00008885

MECHANICAL

HYDRAULIC LASH ADJUSTER (HLA) INSPECTION

id011000805000

1. Visually inspect the HLA surface where it contacts the rocker arm for wear or damage.
 - If there is any malfunction, replace the HLA.

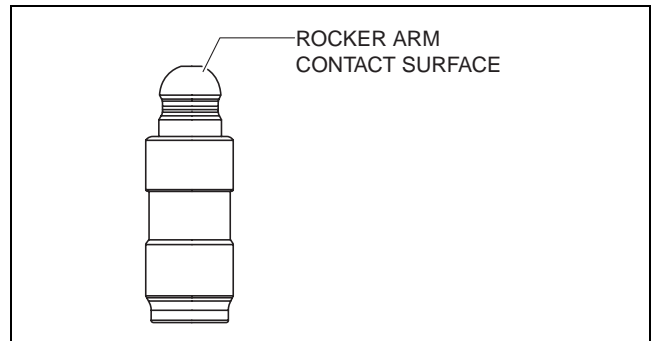

am3uuw00008989

01-10

ROCKER ARM INSPECTION

1. Rotate the roller or the rocker arm by hand and verify that rotates smoothly.
 - If it does not rotate smoothly, replace the rocker arm.
2. Visually inspect the rocker arm surface where it contacts the HLA and valve stem for wear or damage.
 - If there is any malfunction, replace the rocker arm.

id011000904800

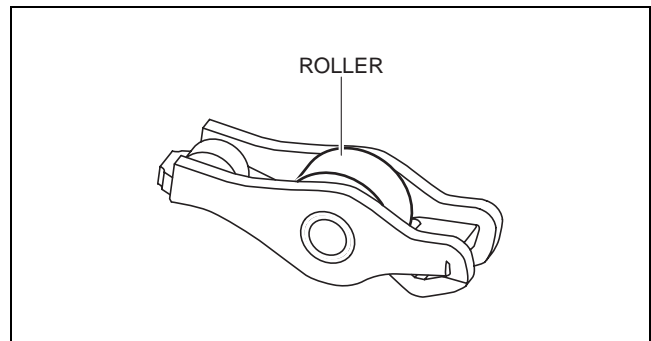

bpe2ue00000096

ENGINE OVERHAUL SERVICE WARNING

id011000503900

Warning

- Continuous exposure to USED engine oil has been shown to cause skin cancer in laboratory mice. Protect your skin by washing with soap and water immediately after performing work.

ENGINE MOUNTING/DISMOUNTING

id011000507000

Mounting

1. Install the **SST** (arms) to the three positions as shown in the figure and temporarily tighten the bolts (Part No. **9YA20-1003** or **M10 × 1.5** length **90 mm {3.55 in}**).

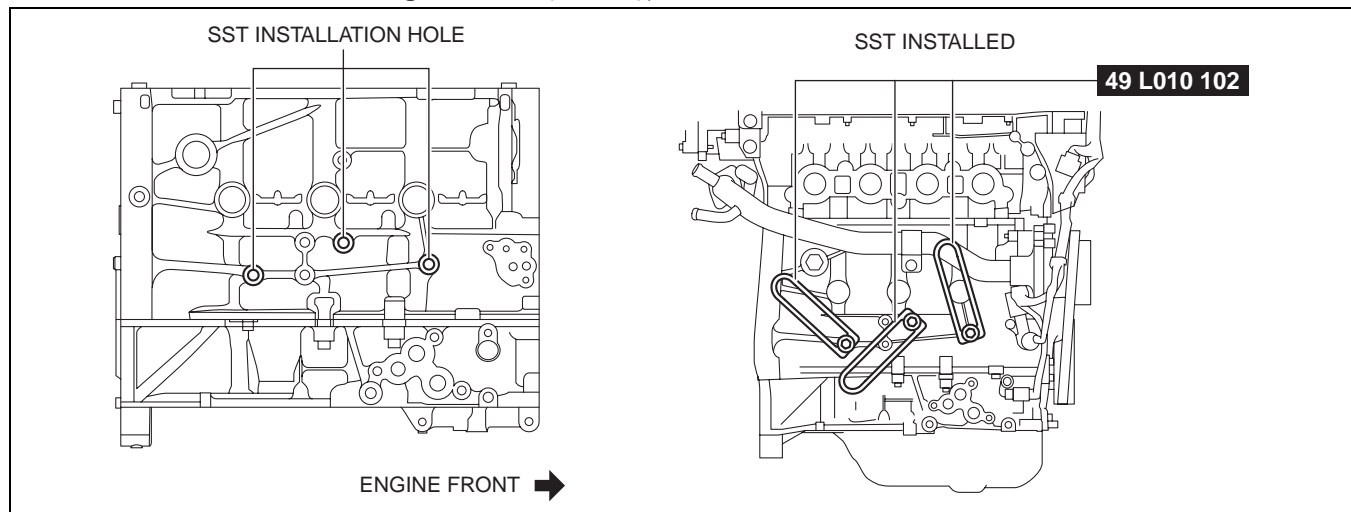

bpe2ue00000088

MECHANICAL

2. Install the **SSTs** (bolts and nuts) to the three positions of the **SST** (plate) as shown in the figure.

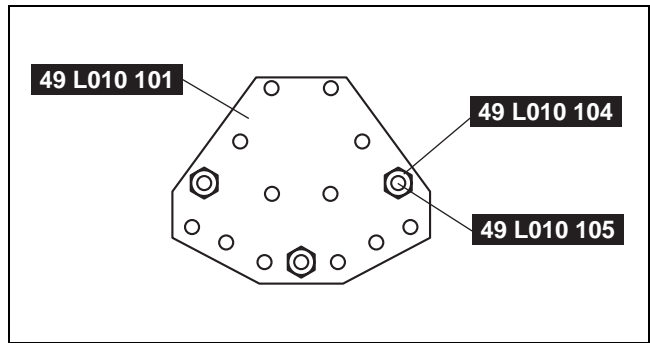

bp31je00000140

3. Install the **SST** (bolts, nuts and plate) set in Step 2 to the **SST** (arms) set in Step 1 using the **SSTs** (hook and nuts).
4. Adjust the bolts so that **approx. 20 mm {0.79 in}** of thread is exposed from the side of the plate.
5. Adjust the bolts and nuts so that the plate and arms are parallel.
6. Tighten the **SSTs** (bolts and nuts) to affix the **SST** firmly.
7. Install the engine to the **SST** (engine stand).
8. Remove the oil drain plug and drain the engine oil.
9. Replace the gasket with a new one and install the oil pan drain plug.

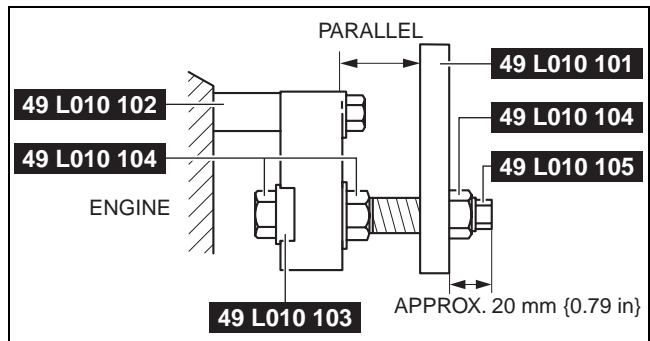

bpe2ue00000089

Tightening torque

30—41 N·m {3.1—4.1 kgf·m, 23—30 ft·lbf}

Dismounting

1. Dismount in the reverse order of mounting.

Caution

- If the camshaft is rotated with the timing chain removed and the piston at the top dead center position, the valve may contact the piston and the engine could be damaged. When rotating the camshaft with the timing chain removed, rotate it after lowering the piston from the top dead center position.
- When rotating the camshaft using a wrench on the cast hexagon, the wrench may contact the rocker arm and damage the rocker arm. To prevent damage to the rocker arm when holding the camshaft on the cast hexagon, use the wrench at engine rear side as shown in the figure to secure a clearance between the cam.

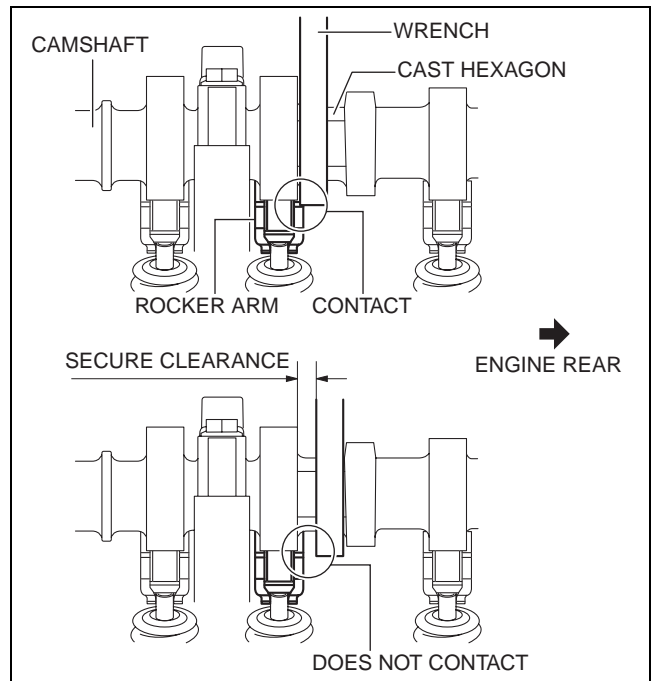

am3uuw00008837

Note

- Width at the cast hexagon of the camshaft is 22—24 mm {0.87—0.94 in}.

1. Disassemble in the order indicated in the table.

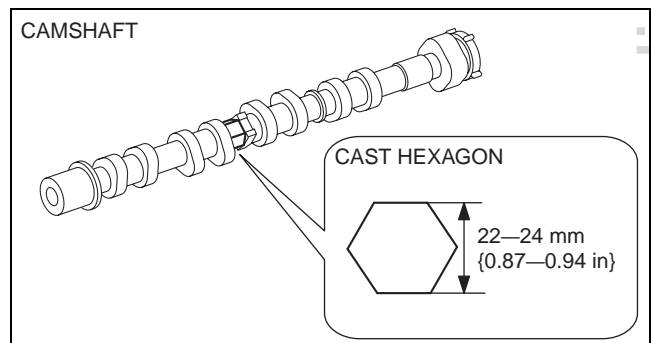

am3uuw00009029

MECHANICAL

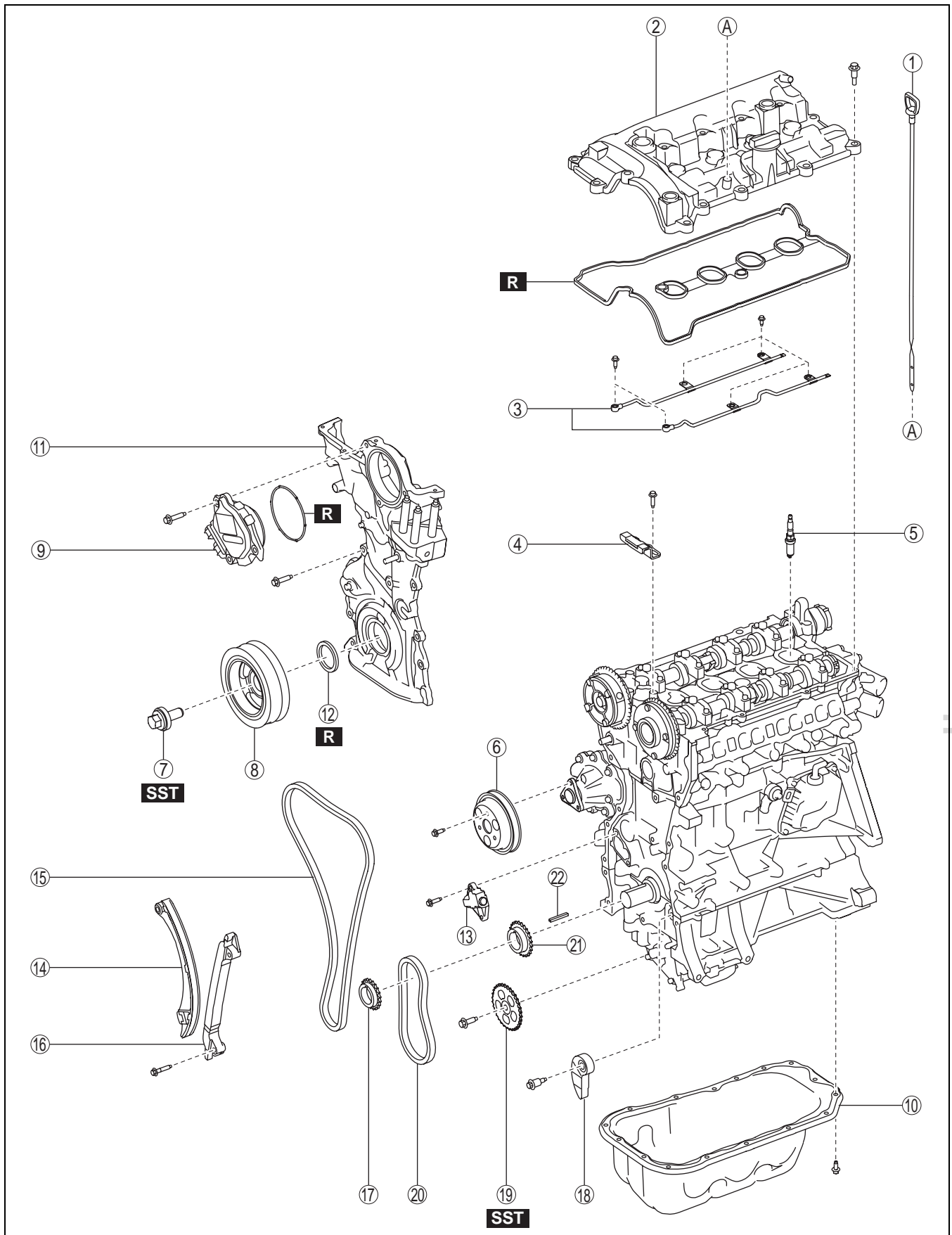

bpe2ue0000074

1	Dipstick
2	Cylinder head cover

3	Oil shower pipe
4	Chain guide (No.1)

MECHANICAL

5	Spark plug
6	Water pump pulley (See 01-10-9 Water Pump Pulley Disassembly Note.)
7	Crankshaft pulley lock bolt (See 01-10-10 Crankshaft Pulley Lock Bolt Disassembly Note.)
8	Crankshaft pulley
9	Electric variable valve timing motor/driver
10	Oil pan (See 01-10-10 Oil Pan Disassembly Note.)
11	Engine front cover (See 01-10-10 Engine Front Cover Disassembly Note.)
12	Front oil seal (See 01-10-11 Front Oil Seal Disassembly Note.)

13	Chain tensioner (See 01-10-11 Chain Tensioner Removal Note.)
14	Tensioner arm
15	Timing chain
16	Chain guide (No.2)
17	Crankshaft sprocket
18	Oil pump chain tensioner
19	Oil pump driven sprocket (See 01-10-12 Oil Pump Driven Sprocket Disassembly Note.)
20	Oil pump chain
21	Oil pump drive sprocket
22	Key

01-10

Water Pump Pulley Disassembly Note

Caution

- Be careful not to damage the belt groove and surface of the water pump pulley when using tools, otherwise it will cause wear, breakage, abnormal noise of the drive belt (stretch belt), damage to the pulley, and rust.

1. Align the water pump pulley hole with the water pump hole as shown in the figure.

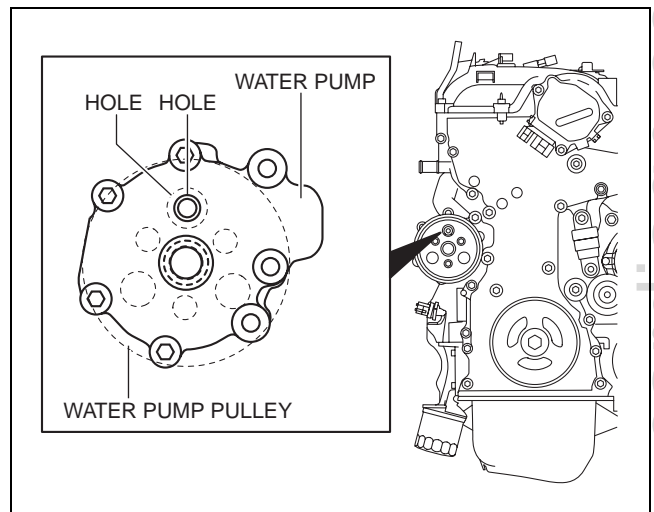

am3uuw00008841

2. Insert an appropriate bolt (length **approx. 70 mm {2.8 in}**) into the water pump hole as shown in the figure, and lock the water pump pulley against rotation.
3. Remove the water pump pulley.
4. Remove the bolt used for locking the water pump pulley against rotation.

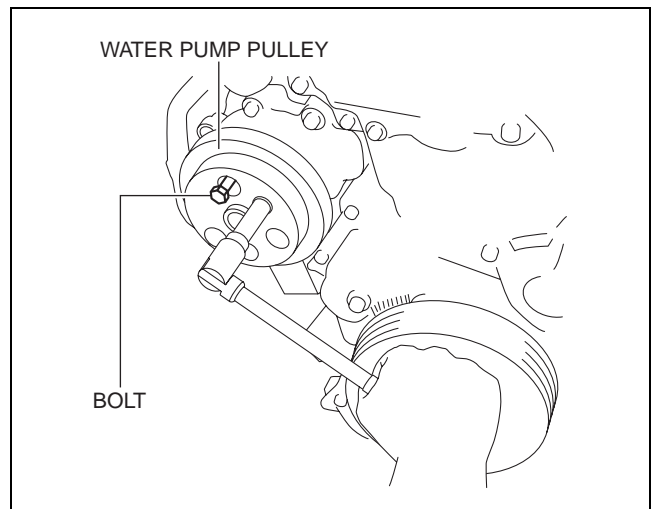

am3uuw00008842

MECHANICAL

Crankshaft Pulley Lock Bolt Disassembly Note

1. Hold the crankshaft using the **SST**.
2. Remove the crankshaft pulley lock bolt.

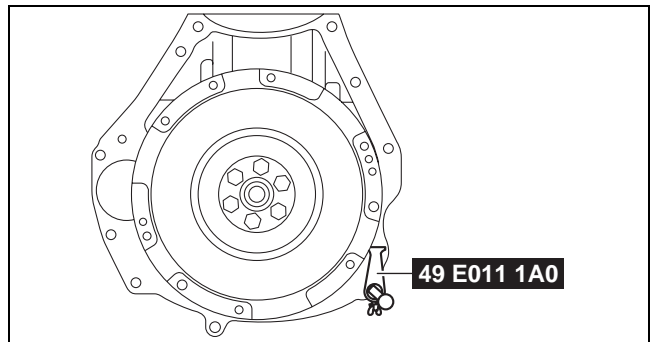

bpe2ue0000075

Oil Pan Disassembly Note

1. Remove the oil pan using a separator tool.

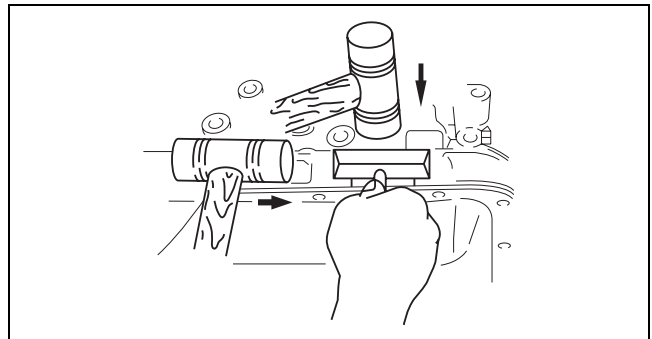

adejjw00003946

Engine Front Cover Disassembly Note

1. Remove the engine front cover installation bolts.
2. Using a screwdriver wrapped in a cloth, peel the sealant away a little at a time, and remove the engine front cover.

Caution

- Do not apply excessive force to the screwdriver. Otherwise, the engine front cover could be damaged.
- Be careful not to scratch or damage the seal surface. Otherwise, it could cause oil leakage.

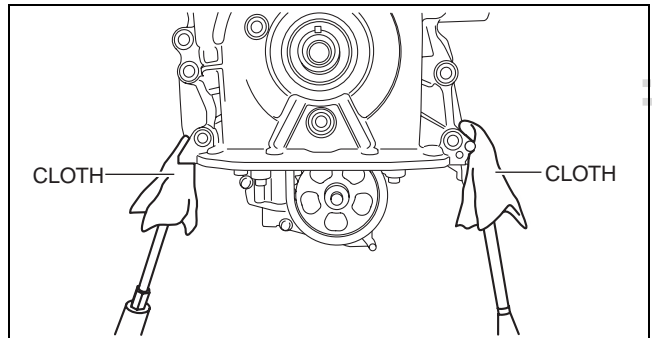

am3uuw00008851

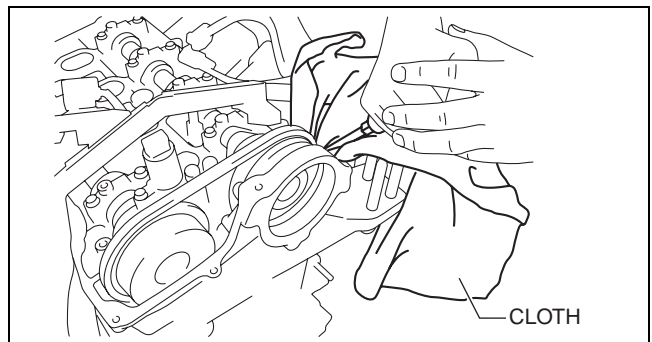

am3uuw00008852

Front Oil Seal Disassembly Note

1. Remove the oil seal using a flathead screwdriver with the tip protected by a clean cloth.

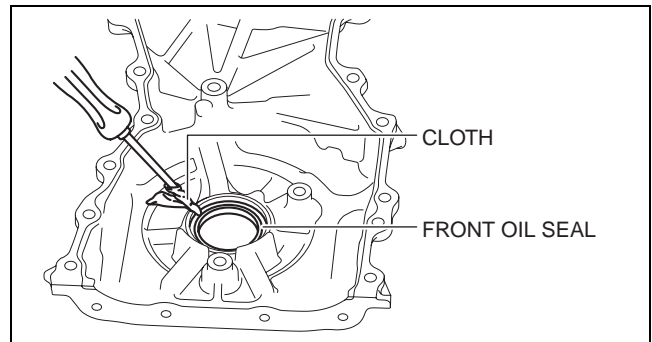

bpe2ue00000100

01-10

Chain Tensioner Removal Note

1. While moving the exhaust camshaft back and forth in the direction of the arrow using a wrench on the cast hexagon, press down the link plate of the timing chain tensioner using a precision screwdriver and release the plunger lock.

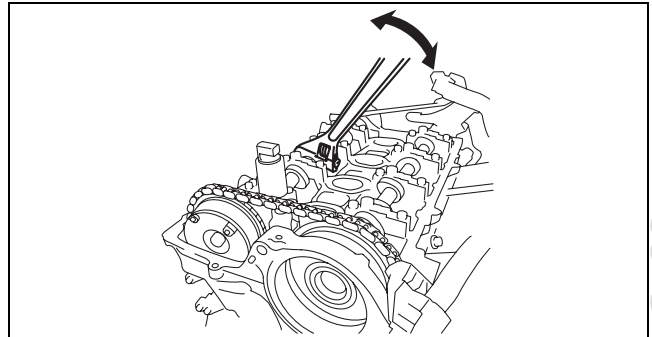

bp31je00000104

Note

- When moving the exhaust camshaft back and forth, the timing chain pushes the plunger in the chain tensioner making it easier to operate the link plate.

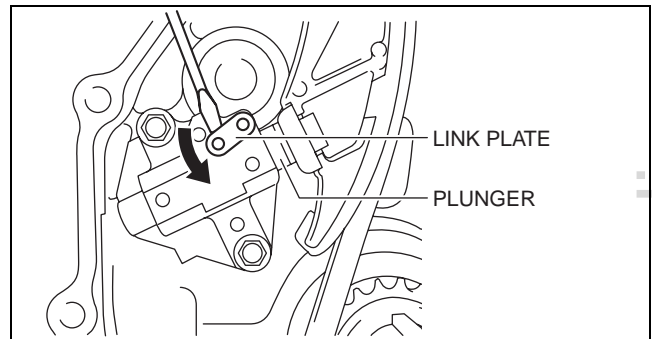

am3uuw00008854

2. Push back the plunger slowly in the direction shown in the figure with the link plate still pushed down.
3. Remove the screwdriver from the link plate with the plunger still pushed down.
4. Release the force slightly from the plunger, and move it back and forth **2—3 mm {0.08—0.11 in}**.

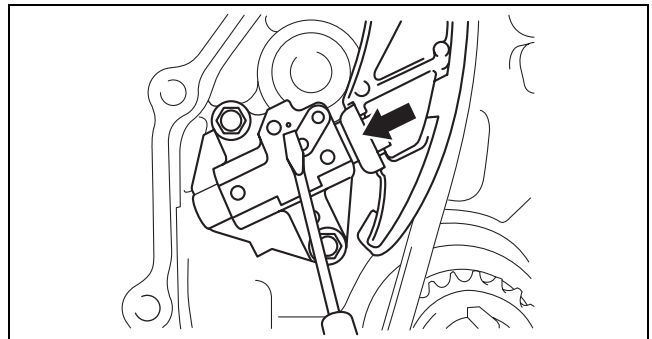

am3uuw00008855

MECHANICAL

5. Insert a wire with an **approx. diameter of 1.5 mm {0.059 in}** or a paper clip where the link plate hole and the tensioner body hole overlap to secure the link plate and lock the plunger.
6. Remove the chain tensioner.

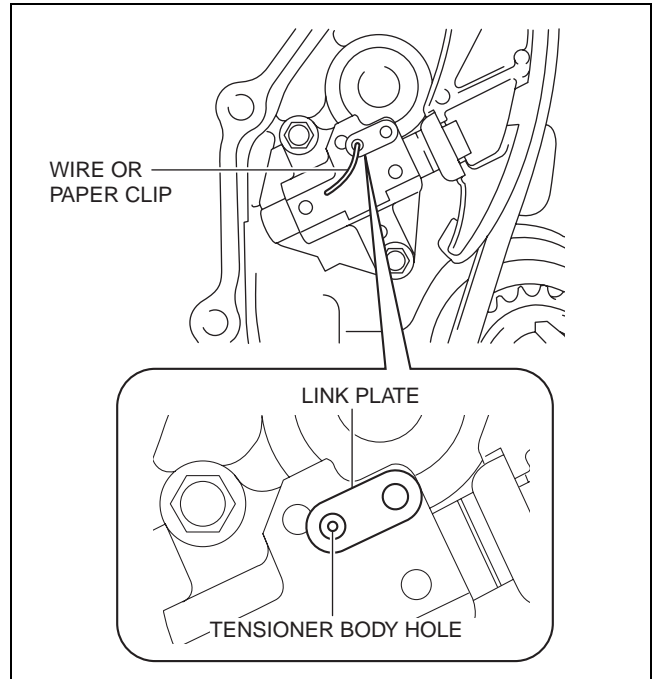

am3uuw00008856

Oil Pump Driven Sprocket Disassembly Note

1. Hold the crankshaft using the **SST**.
2. Remove the oil pump driven sprocket.

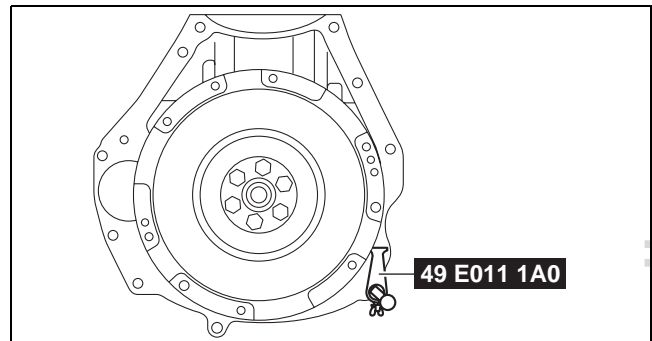

bpe2ue00000075

cardiagn.com

Caution

- If the camshaft is rotated with the timing chain removed and the piston at the top dead center position, the valve may contact the piston and the engine could be damaged. When rotating the camshaft with the timing chain removed, rotate it after lowering the piston from the top dead center position.
- When rotating the camshaft using a wrench on the cast hexagon, the wrench may contact the rocker arm and damage the rocker arm. To prevent damage to the rocker arm when holding the camshaft on the cast hexagon, use the wrench at engine rear side as shown in the figure to secure a clearance between the cam.

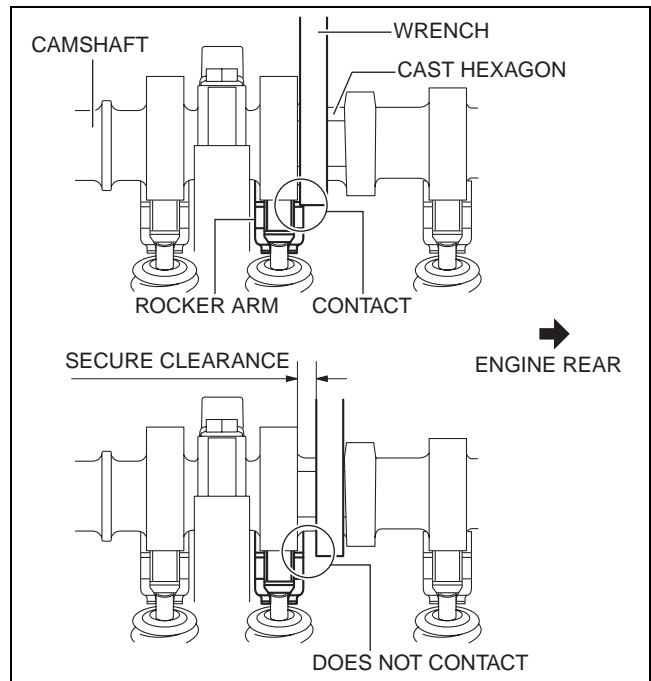

am3uuw00008837

Note

- Width at the cast hexagon of the camshaft is 22—24 mm {0.87—0.94 in}.

1. Disassemble in the order indicated in the table.

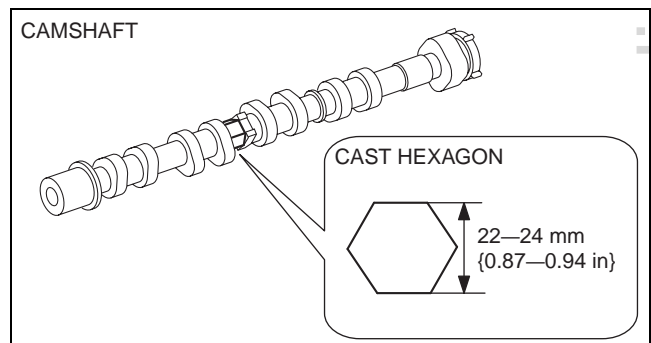

am3uuw00009029

MECHANICAL

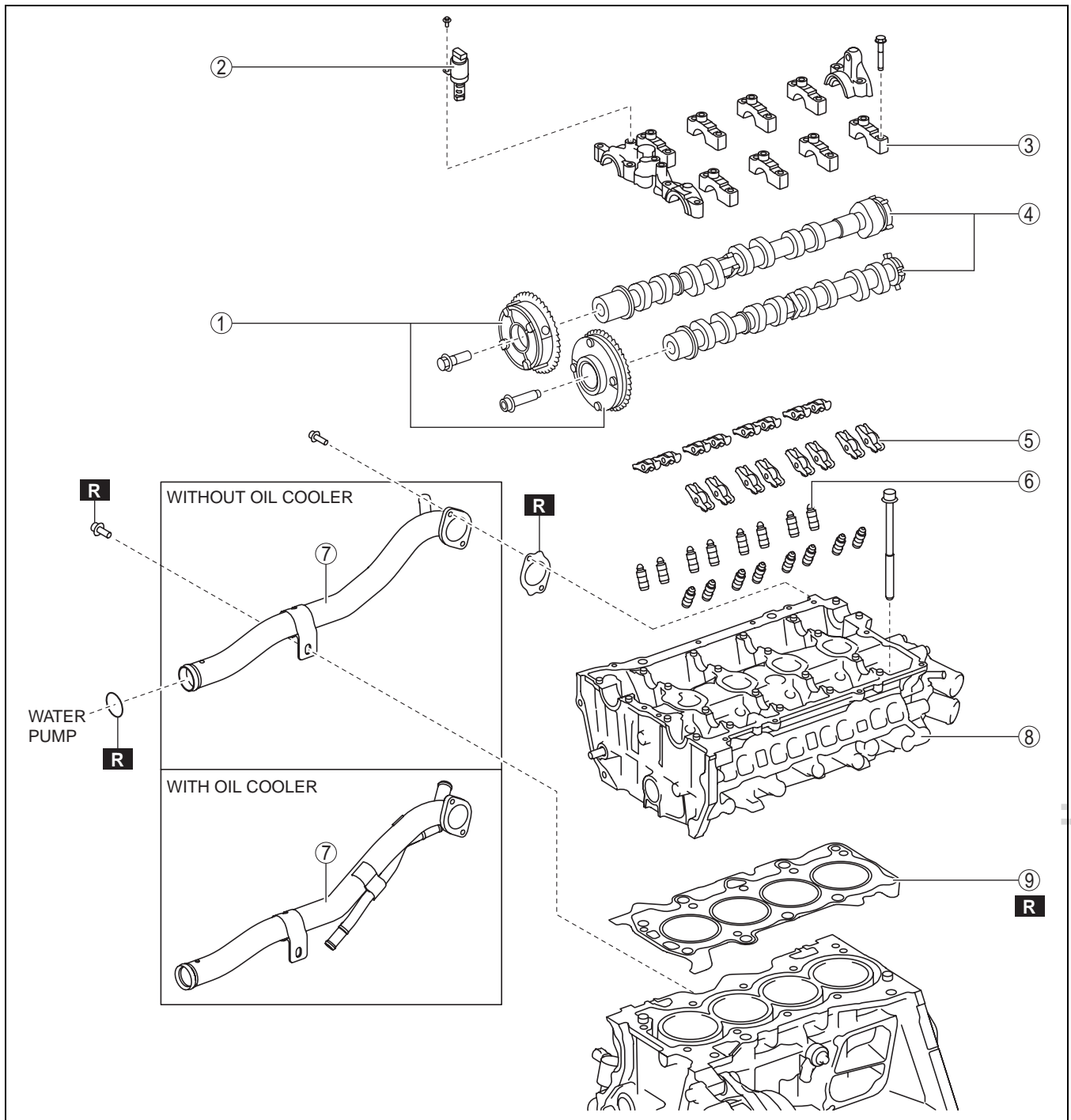

bpe2ue0000013

1	Electric variable valve timing actuator, hydraulic variable valve timing actuator (See 01-10-15 Electric Variable Valve Timing Actuator, Hydraulic Variable Valve Timing Actuator Disassembly Note.)
2	OCV
3	Camshaft cap (See 01-10-15 Camshaft Cap Disassembly Note.)
4	Camshaft

5	Rocker arm (See 01-10-15 Rocker Arm Disassembly Note.)
6	HLA (See 01-10-15 HLA Disassembly Note.)
7	Water inlet pipe
8	Cylinder head (See 01-10-15 Cylinder Head Disassembly Note.)
9	Cylinder head gasket

MECHANICAL

Electric Variable Valve Timing Actuator, Hydraulic Variable Valve Timing Actuator Disassembly Note

1. Hold the camshaft using a wrench on the cast hexagon and loosen the actuator installation bolt.

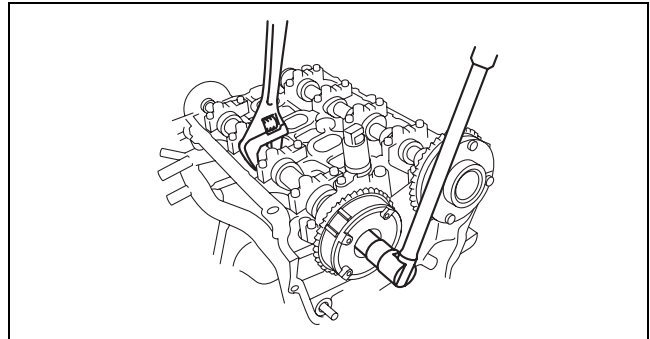

bp31je00000161

01-10

Camshaft Cap Disassembly Note

1. Before removing the camshaft cap, inspect the camshaft end play. (See 01-10-28 CAMSHAFT INSPECTION.)
2. Loosen the camshaft cap installation bolts in two or three passes in the order shown in the figure and remove the camshaft caps.

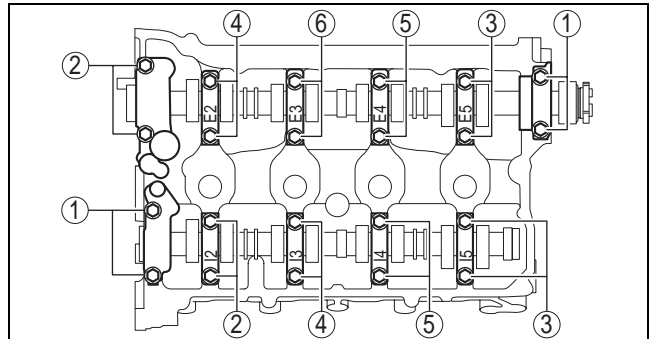

am3uuw00008985

Rocker Arm Disassembly Note

1. Keep the rocker arms in the order of removal to enable reassembly in their original positions.

HLA Disassembly Note

1. Keep the HLAs in the order of removal to enable reassembly in their original positions.

Cylinder Head Disassembly Note

1. Loosen the cylinder head installation bolts in two or three passes in the order shown in the figure and remove them.

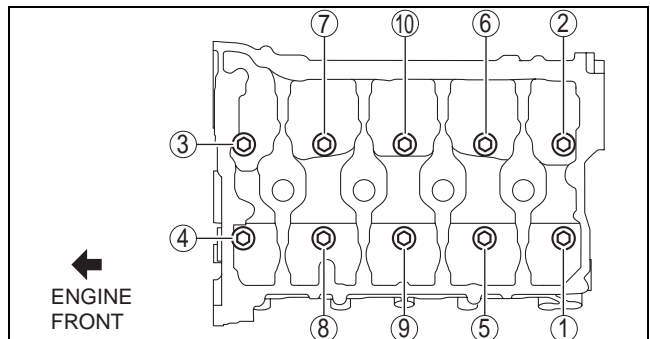

bpe2ue00000014

MECHANICAL

CYLINDER HEAD DISASSEMBLY (II)

id011000500500

1. Disassemble in the order indicated in the table.

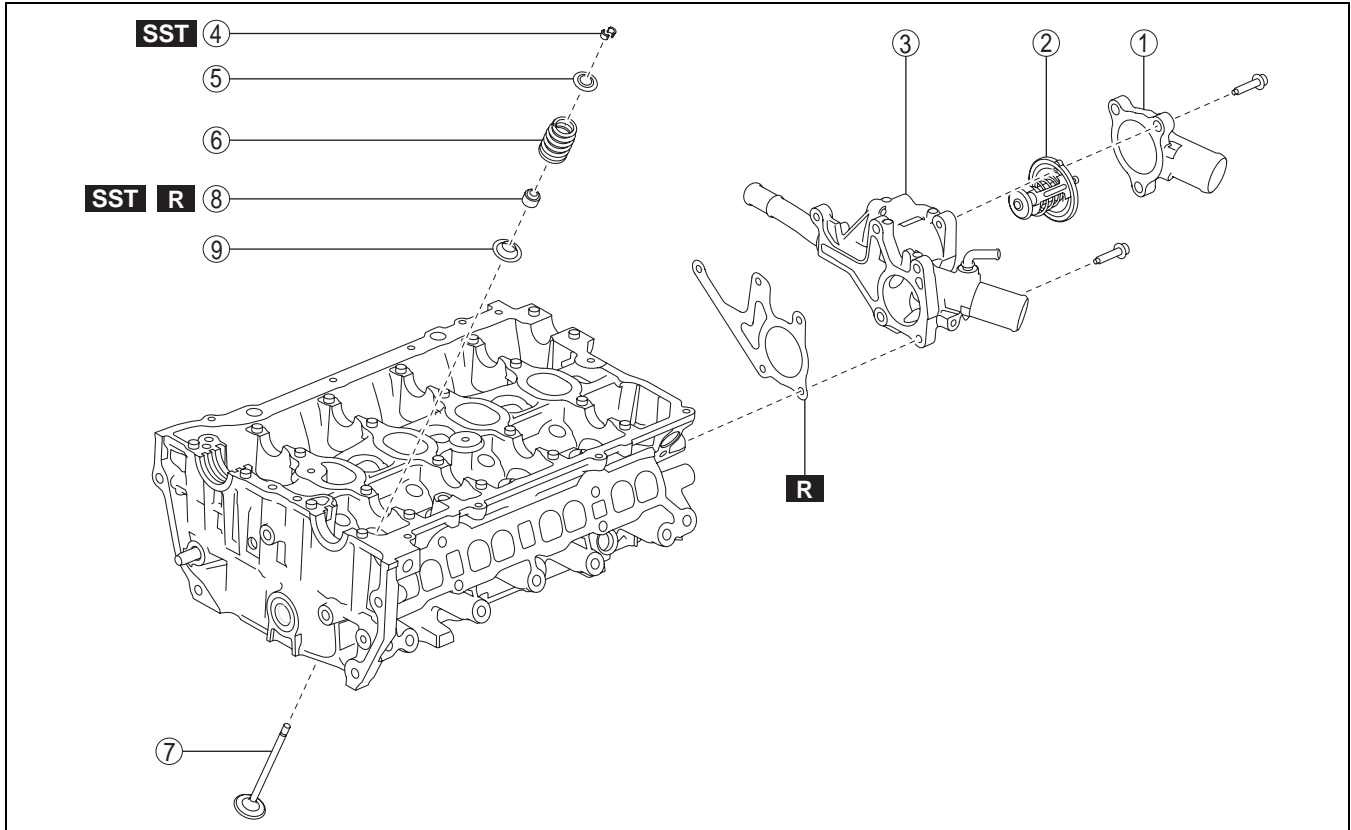

bpe2ue00000015

1	Thermostat cover
2	Thermostat
3	Water outlet
4	Valve keeper (See 01-10-17 Valve Keeper Disassembly Note.)
5	Upper valve spring seat

6	Valve spring
7	Valve
8	Valve seal (See 01-10-17 Valve Seal Disassembly Note.)
9	Lower valve spring seat

cardiagn.com

Valve Keeper Disassembly Note

1. Remove the valve keeper using the **SSTs**.

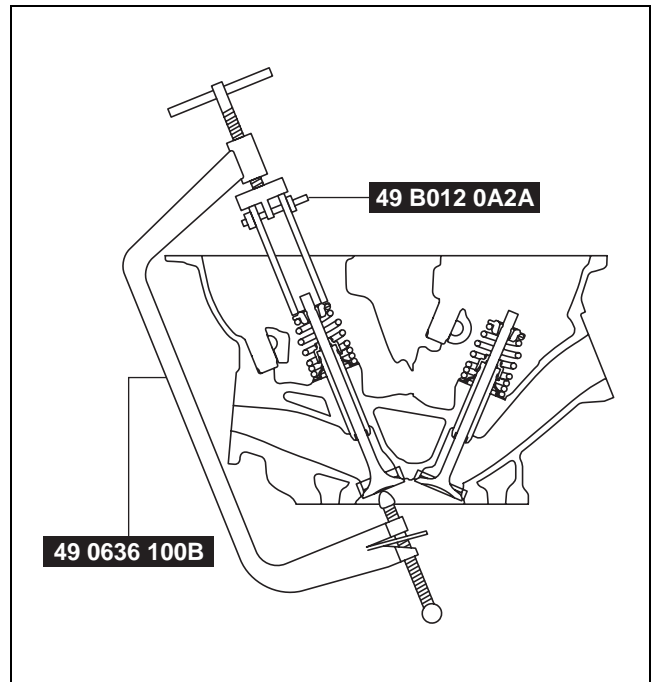

bp31je00000163

01-10

Valve Seal Disassembly Note

1. Remove the valve seal using the **SST** or pliers, etc.

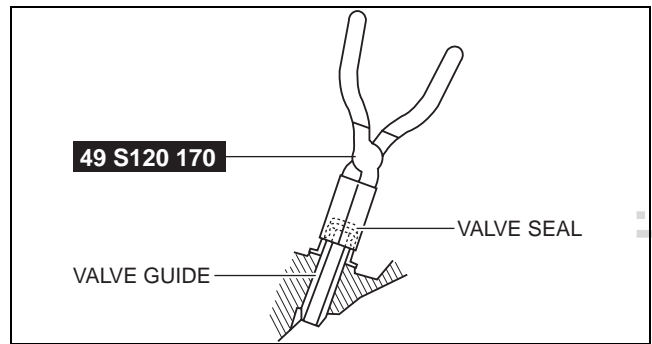

bpe2ue00000016

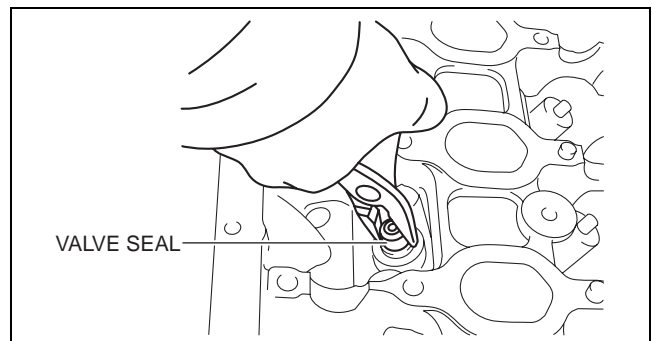

bpe2ue00000017

MECHANICAL

CYLINDER BLOCK DISASSEMBLY (I)

id011000500600

Caution

- Do not disassemble the oil pump and water pump because it is a precision unit.

1. Disassemble in the order indicated in the table.

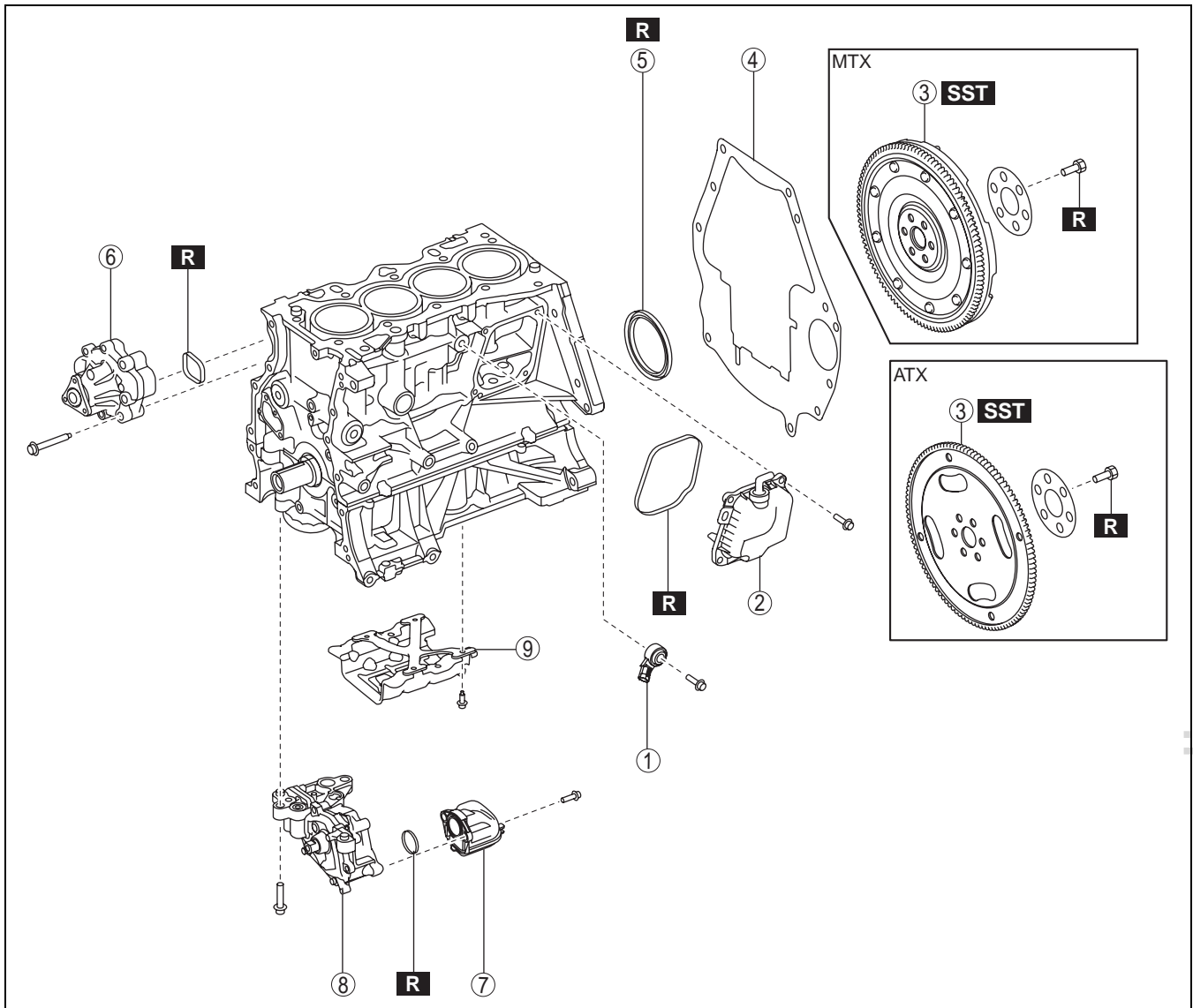

bpe2ue00000018

1	Knock sensor
2	Oil separator
3	Flywheel (MTX), Drive plate (ATX) (See 01-10-19 Flywheel (MTX), Drive Plate (ATX) Disassembly Note.)
4	End plate

5	Rear oil seal (See 01-10-19 Rear Oil Seal Removal Note.)
6	Water pump
7	Oil strainer
8	Oil pump
9	Oil baffle plate

MECHANICAL

Flywheel (MTX), Drive Plate (ATX) Disassembly Note

1. Hold the crankshaft using the **SST**.

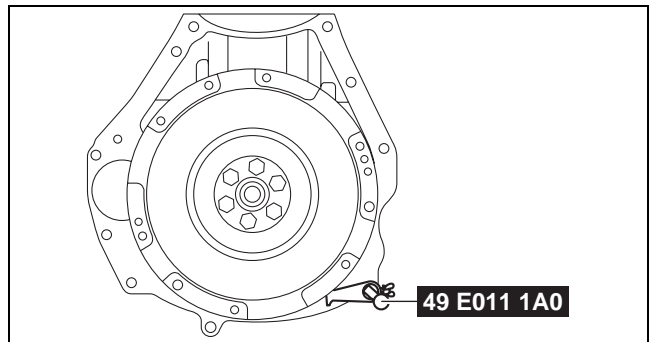

bpe2ue0000019

01-10

Rear Oil Seal Removal Note

1. Cut the oil seal lip using a utility knife.
2. Remove the oil seal using a flathead screwdriver with the tip protected by a clean cloth to prevent damage to the oil seal sliding part of the crankshaft.

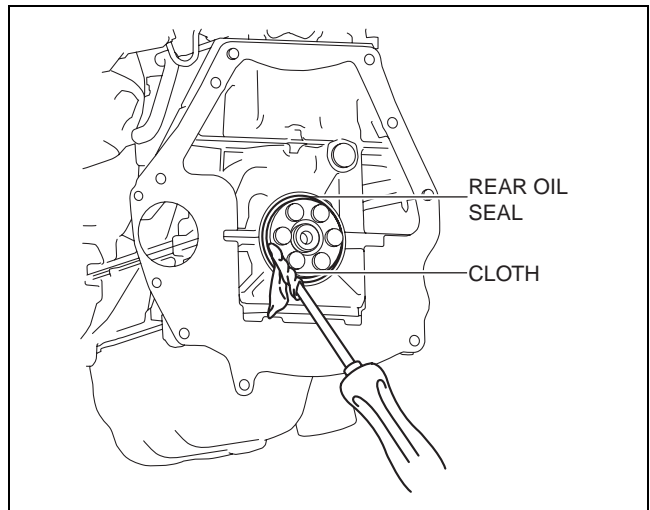

am3uuw00008834

cardiagn.com

MECHANICAL

CYLINDER BLOCK DISASSEMBLY (II)

id011000500700

1. Disassemble in the order indicated in the table.

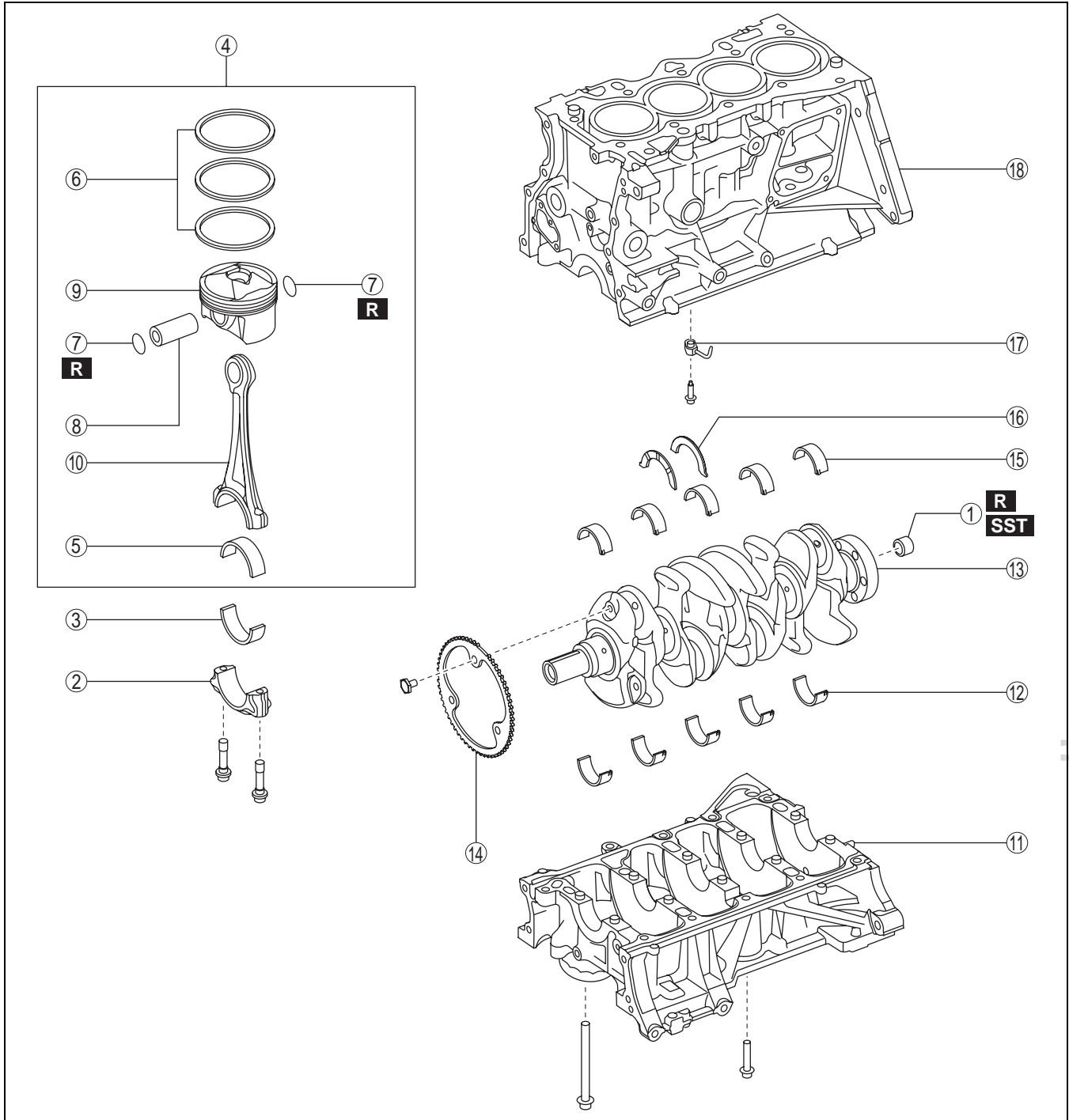

bpe2ue0000020

1	Pilot bearing (MTX) (See 01-10-21 Pilot Bearing Disassembly Note.)
2	Connecting rod cap (See 01-10-21 Connecting Rod Cap Disassembly Note.)
3	Lower connecting rod bearing (See 01-10-21 Connecting Rod Bearing Disassembly Note.)
4	Piston, connecting rod (See 01-10-21 Piston, Connecting Rod Disassembly Note.)

5	Upper connecting rod bearing (See 01-10-21 Connecting Rod Bearing Disassembly Note.)
6	Piston ring
7	Snap ring (See 01-10-22 Snap Ring Disassembly Note.)
8	Piston pin
9	Piston
10	Connecting rod

MECHANICAL

11	Lower cylinder block (See 01-10-22 Lower Cylinder Block Disassembly Note.)
12	Lower main bearing (See 01-10-23 Thrust Bearing And Main Bearing Disassembly Note.)
13	Crankshaft (See 01-10-23 Crankshaft Disassembly Note.)
14	Plate

15	Upper main bearing (See 01-10-23 Thrust Bearing And Main Bearing Disassembly Note.)
16	Thrust bearing (See 01-10-23 Thrust Bearing And Main Bearing Disassembly Note.)
17	Oil jet valve
18	Upper cylinder block

01-10

Pilot Bearing Disassembly Note

Note

- The pilot bearing does not need to be removed unless you are replacing it.

1. Use the **SST** to remove the pilot bearing.

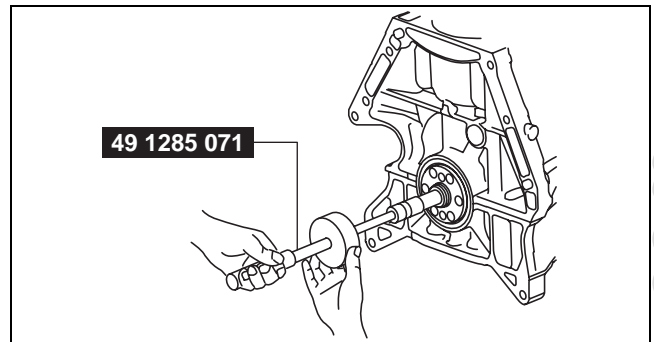

bpe2ue0000021

Connecting Rod Cap Disassembly Note

1. Before removing the connecting rod cap, inspect the connecting rod side clearance. (See 01-10-33 CONNECTING ROD CLEARANCE INSPECTION.)
2. The removed connecting rod caps are to be kept so that they can be assembled to the same positions and in the direction as before removal.

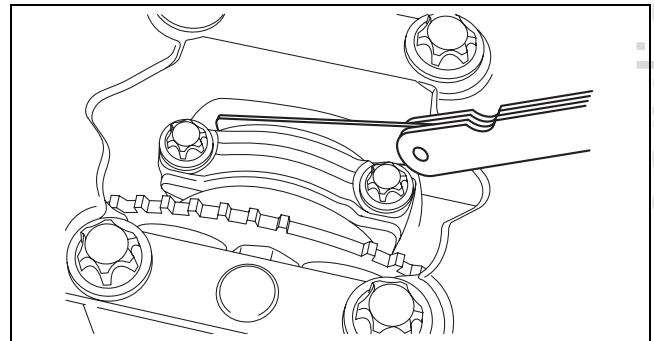

bp31je0000044

Connecting Rod Bearing Disassembly Note

1. The removed connecting rod bearings are to be kept so that they can be assembled to the same positions and in the direction as before removal.

Piston, Connecting Rod Disassembly Note

1. Before removing the piston and connecting rod, remove the carbon in the cylinder.
2. Before removing the piston and connecting rod, inspect the oil clearance at the large end of the connecting rod. (See 01-10-33 CONNECTING ROD CLEARANCE INSPECTION.)

MECHANICAL

Snap Ring Disassembly Note

1. Before removing the snap ring, inspect that the large end of connecting rod drops under its own weight with no resistance. (See 01-10-33 PISTON AND CONNECTING ROD INSPECTION.)
2. Remove the snap ring using a flathead screwdriver.

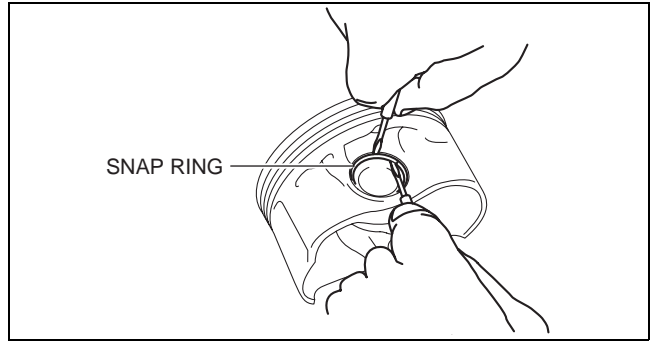

bpe2ue0000022

Lower Cylinder Block Disassembly Note

1. Before removing the lower cylinder block, inspect the crankshaft end play. (See 01-10-34 CRANKSHAFT INSPECTION.)
2. Loosen the lower cylinder block installation bolts A in two or three passes in the order shown in the figure and remove them.

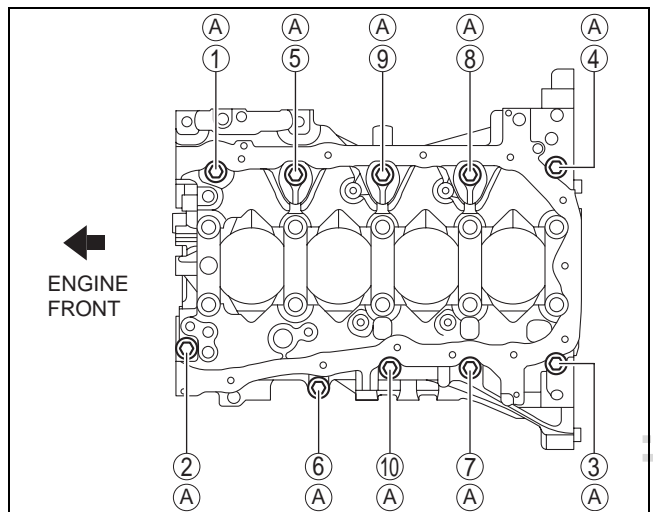

bpe2ue0000023

3. Loosen the lower cylinder block installation bolts B in two or three passes in the order shown in the figure and remove them.

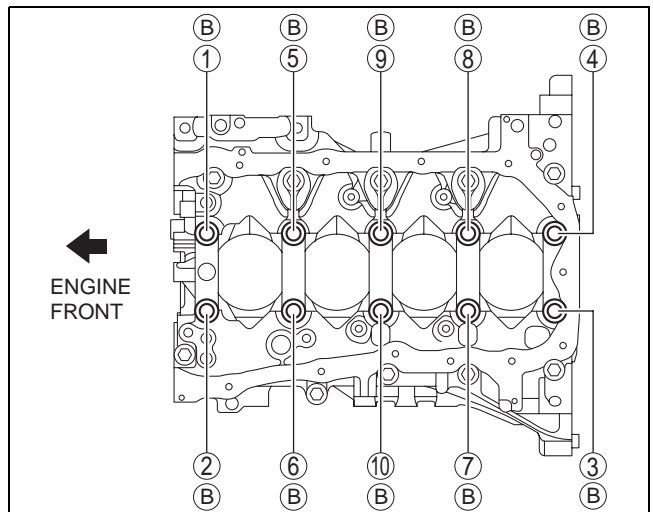

bpe2ue0000024

cardiagn.com

MECHANICAL

- Using a screwdriver wrapped in a cloth, peel the sealant away a little at a time, and remove the lower cylinder block.

Caution

- Do not apply excessive force to the screwdriver. Otherwise, the lower cylinder block could be damaged.
- Be careful not to scratch or damage the seal surface. Otherwise, it could cause oil leakage.

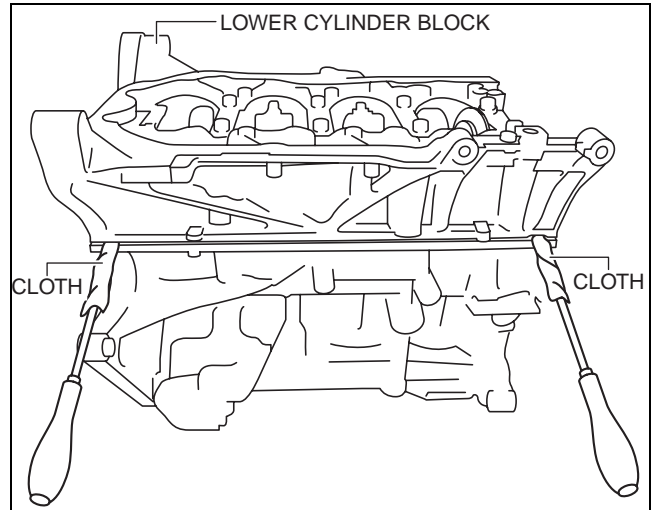

bpe2ue0000025

01-10

Thrust Bearing And Main Bearing Disassembly Note

- The removed thrust bearings and main bearings are to be kept so that they can be assembled to the same positions and in the direction as before removal.

Crankshaft Disassembly Note

Caution

- Placing the crankshaft on a disassembly bench will deform or damage it because the plate for the crankshaft position sensor signal detection installed to the crankshaft is larger than the counterweight. Therefore, set wood blocks or similar objects on the both sides of the crankshaft so that the plate does not contact the disassembly bench directly when placing the crankshaft on it bench.

CYLINDER HEAD INSPECTION

id011000507100

- Inspect the cylinder head surface for cracks and other damage using a red dye penetrant.
 - If there is a malfunction, replace the cylinder head.
- Measure the combustion chamber side of the cylinder head for distortion in six directions as shown in the figure using a straight edge and feeler gauge.
 - If the distortion exceeds the maximum specification, replace the cylinder head.

Maximum distortion, head gasket side of the cylinder head
0.05 mm {0.002 in}

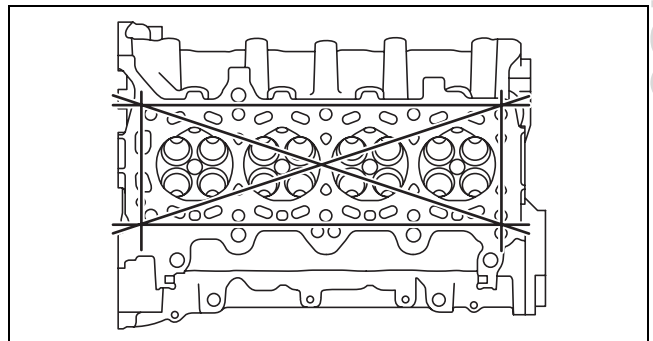

bp31je00000142

cardiagn.com

MECHANICAL

3. Inspect the contact surface of the exhaust manifold and the intake manifold for distortion by measuring as shown in the figure using a straight edge and feeler gauge.

- If the distortion on intake manifold side exceeds the maximum specification, replace the cylinder head.
- If the distortion on exhaust manifold side exceeds the maximum specification, grind the surface or replace the cylinder head.

Maximum distortion, manifold side

IN: 0.10 mm {0.0039 in}

EX: 0.05 mm {0.002 in}

Maximum cutting length, manifold side

IN: Cutting not authorized

EX: 0.20 mm {0.0079 in}

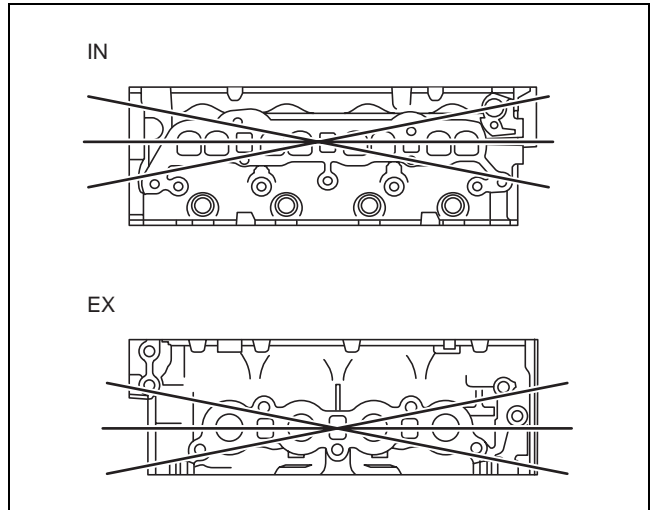

bpe2ue00000090

VALVE SEAT INSPECTION/REPAIR

1. Measure the contact width of the valve face and the valve seat using the valve lapping compound.
- If it is not within the specification, resurface the valve seat using the **45°** valve seat cutter.

Standard valve seat contact width

1.41 mm {0.0555 in}

Valve seat angle

45°

2. Verify that the area where the valve seat contacts the valve face is centered.

- If the seating position is too high, correct the valve seat using a **70°** (IN) **70°** (EX) valve seat cutter and a **45°** valve seat cutter.
- If the seating position is too low, correct as follows:
 - IN: Correct the valve seat using a **20°** valve seat cutter and then using a **45°** valve seat cutter.
 - EX: Correct the valve seat using a **45°** valve seat cutter.

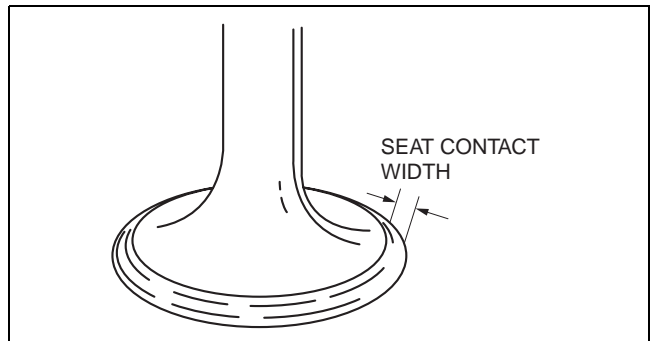

id011000501300

bpe2ue00000028

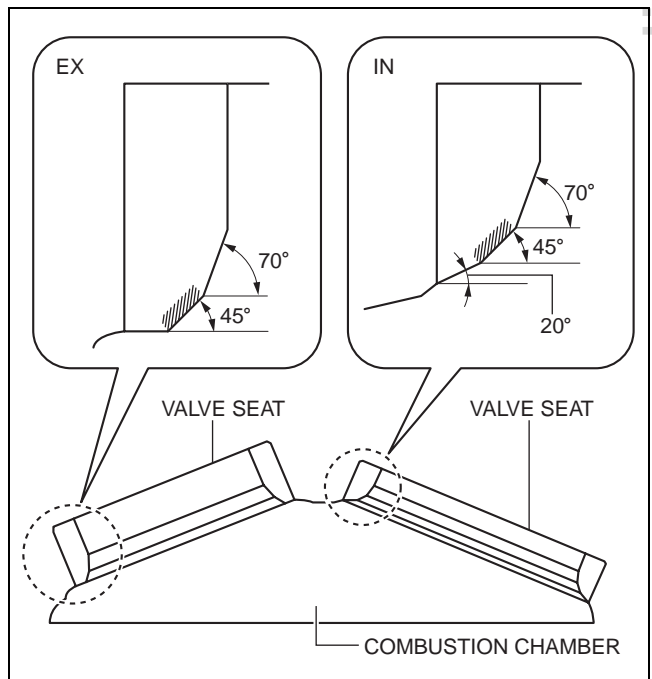

bpe2ue00000029

- Inspect the valve seat for sinkage. Measure the protruding length (dimension L) of the valve stem using a valve of standard length.
 - If it is not within the specification, replace the cylinder head.

**Standard valve seat sinkage amount
(Dimension L)**

IN: 48.73—50.27 mm {1.919—1.979 in}
EX: 48.73—50.27 mm {1.919—1.979 in}

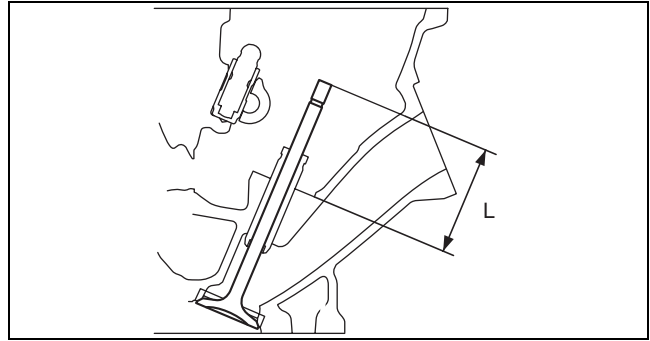

bp31je00000051

VALVE, VALVE GUIDE INSPECTION

- Measure the valve head margin thickness using a vernier caliper.
 - If it is less than the standard specification, replace the valve.

Standard valve head margin thickness

IN: 1.75—1.95 mm {0.0689—0.0767 in}
EX: 1.95—2.15 mm {0.0768—0.0846 in}

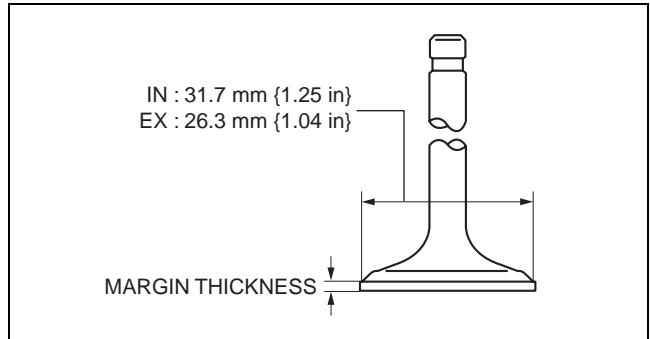

id011000506200

bpe2ue00000083

- Measure the length of the each valve using a vernier caliper.
 - If it is less than the minimum specification, replace the valve.

Standard valve length

IN: 106.55—107.15 mm {4.1949—4.2185 in}
EX: 116.55—117.15 mm {4.5886—4.6122 in}

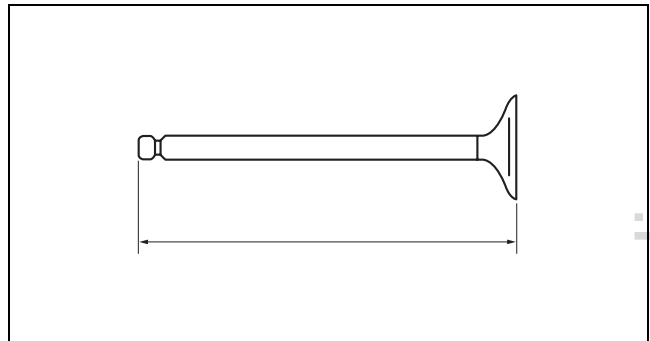

bez0je00000017

Minimum valve length

IN: 106.33 mm {4.1862 in}
EX: 116.33 mm {4.5799 in}

- Measure the valve stem diameter of each valve using the micrometer. Measurement positions total six and are in the X and Y directions, at three points (A, B, and C) as shown in the figure.
 - If it is less than the minimum specification, replace the valve.

Standard valve stem diameter

IN: 5.470—5.485 mm {0.2154—0.2159 in}
EX: 5.465—5.480 mm {0.2152—0.2157 in}

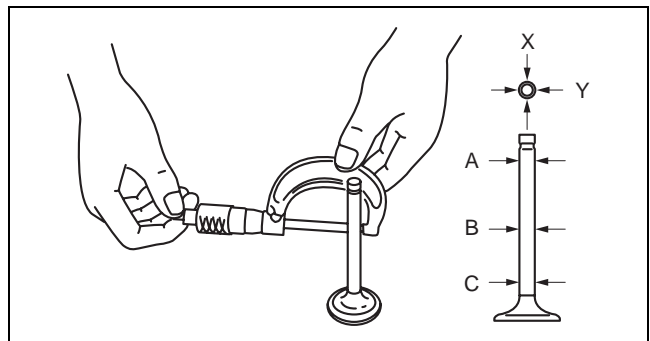

bpe2ue00000084

Minimum valve stem diameter

IN: 5.424 mm {0.2135 in}
EX: 5.419 mm {0.2133 in}

MECHANICAL

4. Measure the inner diameter of each valve guide using the caliper gauge. Measurement positions total six and are in the X and Y directions, at three points (A, B, and C) as shown in the figure.
- If it is not within the specification, replace the valve guide.

Standard valve guide inner diameter

IN: 5.510—5.530 mm {0.2170—0.2177 in}

EX: 5.510—5.530 mm {0.2170—0.2177 in}

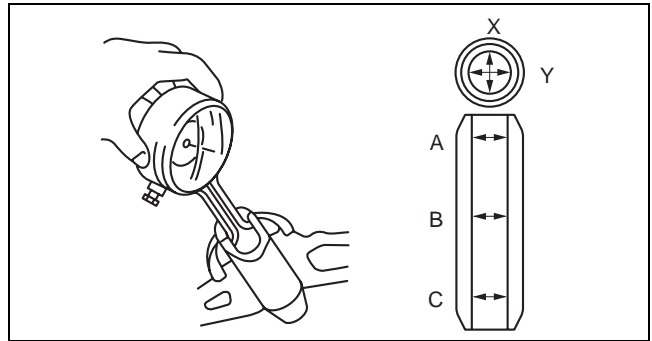

bpe2ue0000085

5. Calculate the clearance between the valve stem and the valve guide by subtracting the inner diameter of the valve guide from the outer diameter of the corresponding valve stem.
- If it exceeds the maximum specification, replace the valve or valve guide.

Standard clearance between valve stem and guide

IN: 0.025—0.060 mm {0.0010—0.0023 in}

EX: 0.030—0.065 mm {0.0012—0.0025 in}

Maximum clearance between valve stem and guide

0.10 mm {0.0039 in}

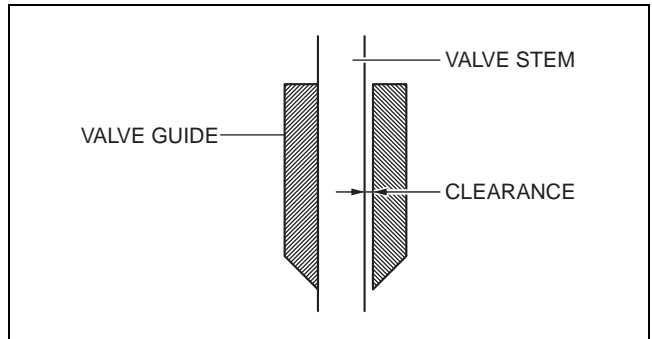

bpe2ue0000086

6. Measure the projection height (dimension A) of each valve guide using the vernier caliper.
- If it is not within the specification, replace the valve guide.

Standard valve guide projection height

IN: 16.4—17.0 mm {0.646—0.669 in}

EX: 16.4—17.0 mm {0.646—0.669 in}

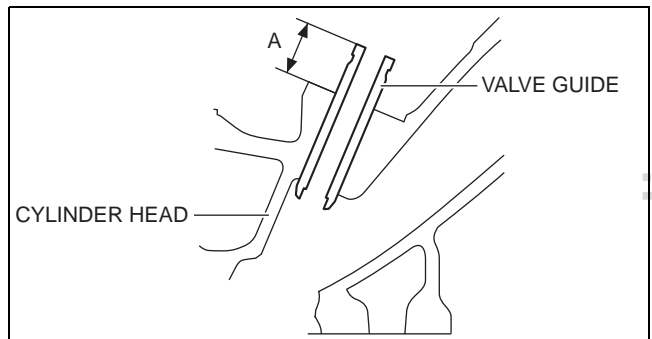

bpe2ue0000087

VALVE GUIDE REPLACEMENT

Removal

1. Tap the valve guide out from combustion chamber side using the SST.

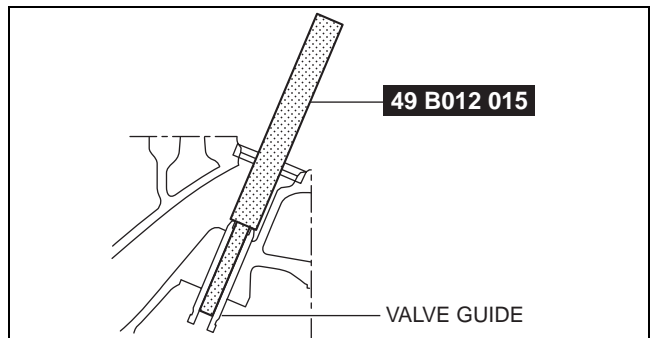

bpe2ue0000026

Installation

1. Apply clean engine oil to the valve guide.
2. Tap the valve guide from the camshaft side using the SST so that the projection height (dimension A) is within the specification.

Standard valve guide projection height

IN: 16.4—17.0 mm {0.646—0.669 in}

EX: 16.4—17.0 mm {0.646—0.669 in}

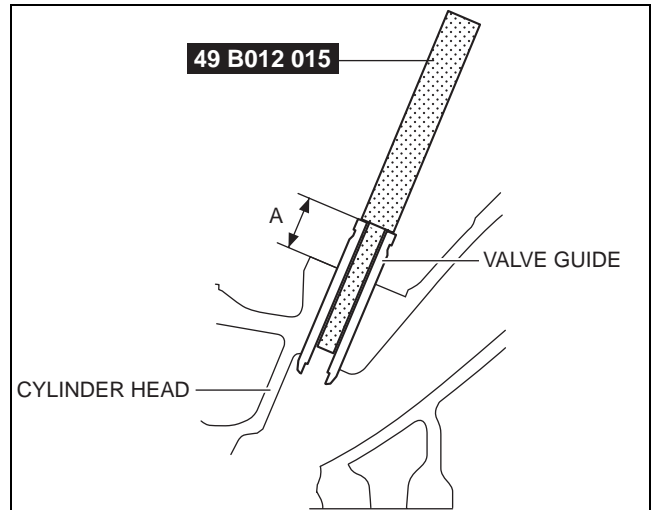

bpe2ue0000027

id011000501400

01-10

VALVE SPRING INSPECTION

Caution

- The valve springs differ depending on the IN and EX sides. Therefore, verify the free length or identification paint beforehand and inspect the valve springs.

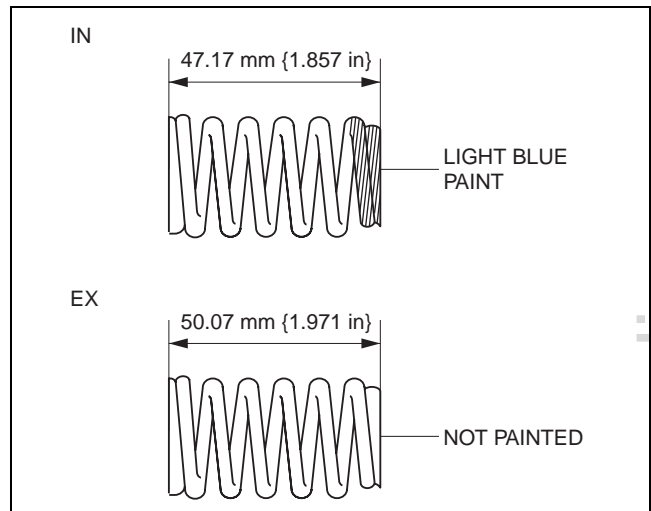

bpe2ue00000030

1. Measure the valve spring height using the spring tester.

- If it is not within the specification, replace the valve spring.

Valve spring installation height

IN: When pressurized with spring force of 190—210 N {19.4—21.4 kgf, 42.8—47.2 lbf}, spring height is 38.0 mm {1.50 in}

EX: When pressurized with spring force of 228—252 N {23.3—25.6 kgf, 51.3—56.6 lbf}, spring height is 38.0 mm {1.50 in}

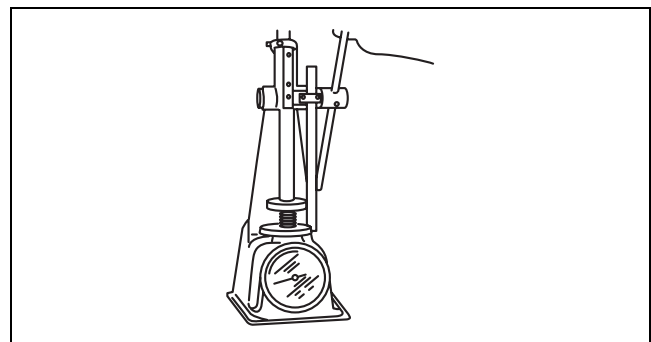

bp31je00000053

MECHANICAL

2. Measure the amount of off-square on the valve spring using a square.
 - (1) Rotate the valve spring one full turn and measure A at the point where the gap is the largest.
 - If it exceeds the maximum specification, replace the valve spring.

Maximum valve spring off-square

IN: 2.0 ° (1.6 mm {0.063 in})

EX: 2.0 ° (1.7 mm {0.067 in})

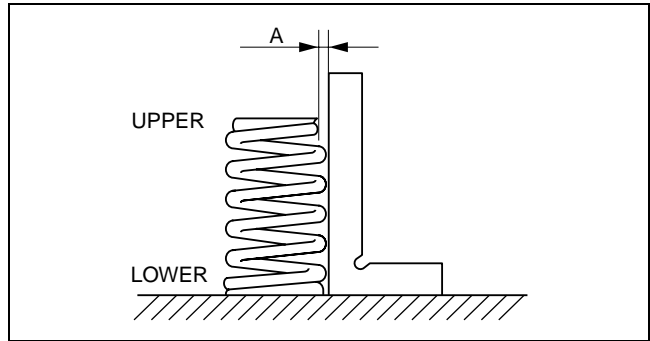

beltze00000017

CAMSHAFT INSPECTION

id011000501500

1. Set the No.1 and No.5 journals of the camshaft on V-blocks.
2. Measure the camshaft runout using the dial gauge.
 - If it exceeds the maximum specification, replace the camshaft.

Maximum camshaft runout

0.030 mm {0.0012 in}

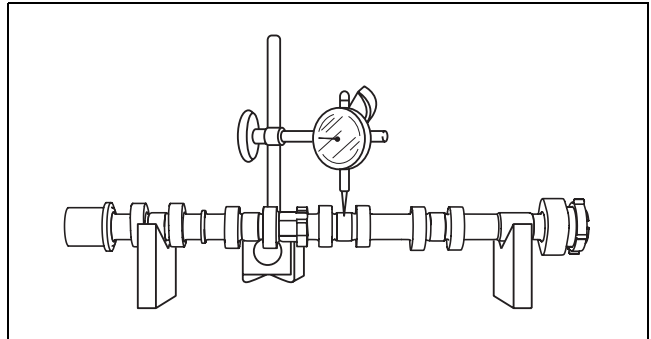

bpe2ue00000031

3. Measure the cam height using the micrometer as shown in the figure.
 - If it is less than the minimum specification, replace the camshaft.

Standard cam height

IN: 41.57 mm {1.637 in}

EX: 40.37 mm {1.589 in}

Minimum cam height

IN: 41.50 mm {1.634 in}

EX: 40.30 mm {1.587 in}

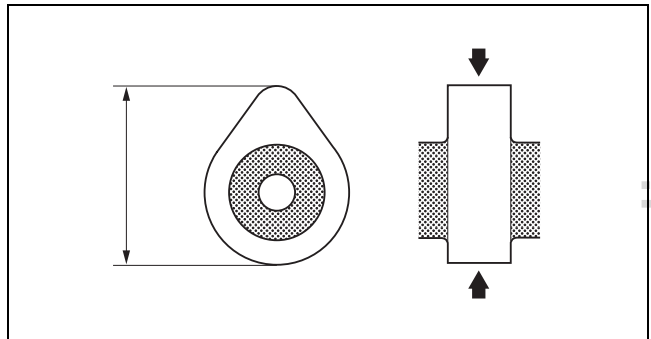

bp31je00000171

4. Measure the journal diameter using the micrometer. Measurement positions total four and are in the X and Y directions, at two points (A and B) as shown in the figure.
 - If it is less than the minimum specification, replace the camshaft.

Standard camshaft journal diameter

24.96—24.98 mm {0.9827—0.9834 in}

Minimum camshaft journal diameter

24.93 mm {0.9815 in}

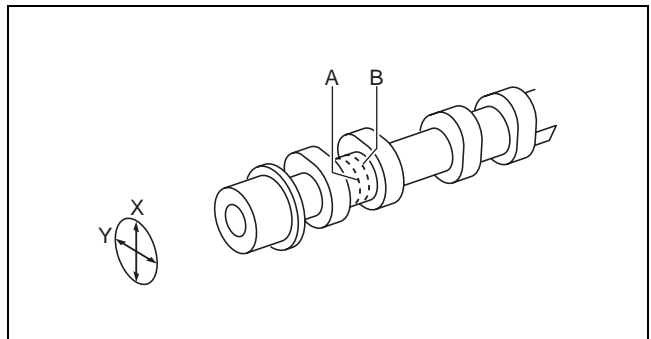

bp31je00000172

5. Measure the camshaft journal oil clearance using the following procedure:

- (1) Clean the camshaft journal and the journal receptacle part.
- (2) Put the camshaft on the cylinder head with the rocker arm detached.
- (3) Cut the plastigauge to the same length as the journal width and position it parallel to the camshaft.
- (4) Install the camshaft caps. (See 01-10-51 CYLINDER HEAD ASSEMBLY (II).)
- (5) Remove the camshaft caps. (See 01-10-13 CYLINDER HEAD DISASSEMBLY (I).)
- (6) Measure the camshaft journal oil clearance.
 - If it exceeds the maximum specification, replace the cylinder head.

Standard camshaft journal oil clearance
0.035—0.080 mm {0.0014—0.0031 in}

Maximum camshaft journal oil clearance
0.090 mm {0.0035 in}

6. Measure the camshaft end play using a dial gauge.

- If it exceeds the maximum specification, replace the cylinder head or camshaft.

Standard camshaft end play
0.07—0.22 mm {0.003—0.008 in}

Maximum camshaft end play
0.23 mm {0.0091 in}

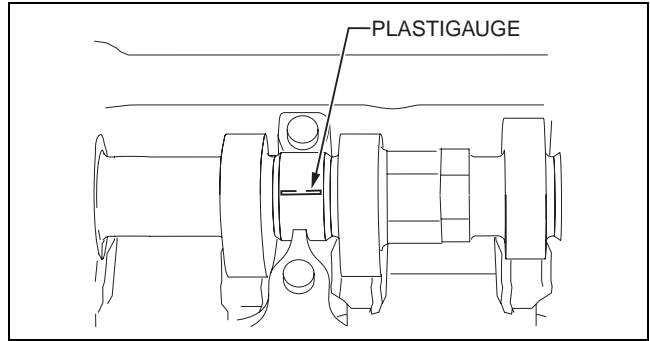

bpe2ue0000032

01-10

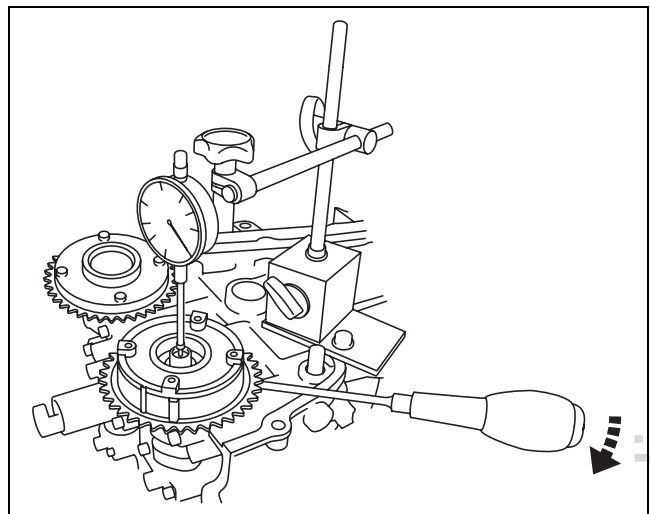

bp31je00000173

CYLINDER BLOCK INSPECTION

id011000507200

1. Measure the cylinder block for distortion in six directions as shown in the figure using a straight edge and feeler gauge.
 - If it exceeds the maximum specification, replace the cylinder block.

Maximum distortion, head gasket side of the cylinder block
0.10 mm {0.0039 in}

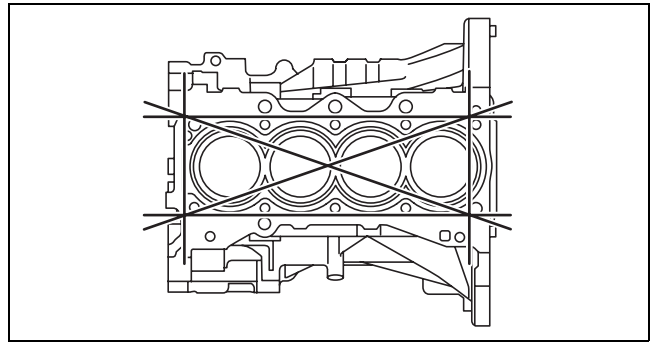

bp31je00000144

2. Measure the cylinder bore diameter using the cylinder gauge. The measurement position is in the X and Y directions at a point **43.9 mm {1.73 in}** below the top surface of the cylinder as shown in the figure.
 - If it is not within the specification, replace the cylinder block.

Standard cylinder bore diameter
83.50—83.53 mm {3.2875—3.2885 in}

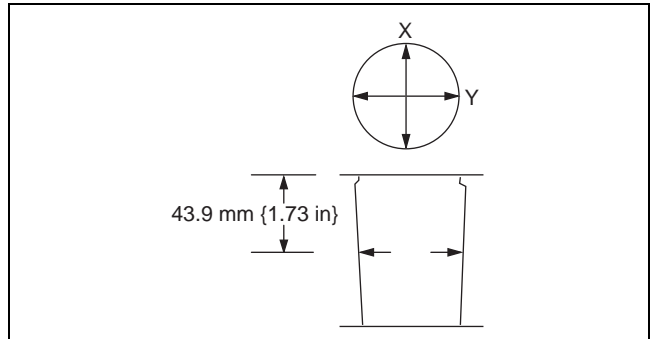

bpe2ue00000098

OIL JET VALVE INSPECTION

id011000505900

1. Apply compressed air to oil jet valve A and verify that air passes through oil jet valve B.
 - If air does not flow, replace the oil jet valve.
 - If there is air flow with air compressor of less than **180 kPa {1.84 kgf/cm², 26.1 psi}**, replace the oil jet valve.

Air pressure
180—220 kPa {1.84—2.24 kgf/cm², 26.2—31.9 psi}

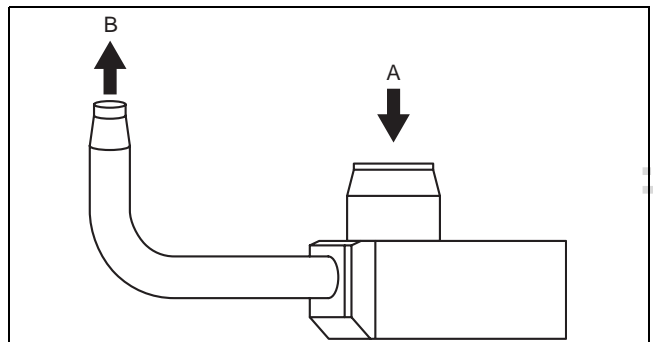

bp31je00000131

PISTON INSPECTION

id011000502100

Caution

- If the piston is replaced, replace the piston, piston pin, and the snap ring as a single component.

1. Measure the piston outer diameter using the micrometer. The measurement position is **8.0 mm {0.31 in}** from the lower end of the piston (area with no coating on the piston skirt) and in the thrust direction.
 - If it is not within the specification, replace the piston.

Standard piston outer diameter
83.465—83.495 mm {3.2861—3.2872 in}

2. Measure the cylinder bore diameter. (See 01-10-30 CYLINDER BLOCK INSPECTION.)

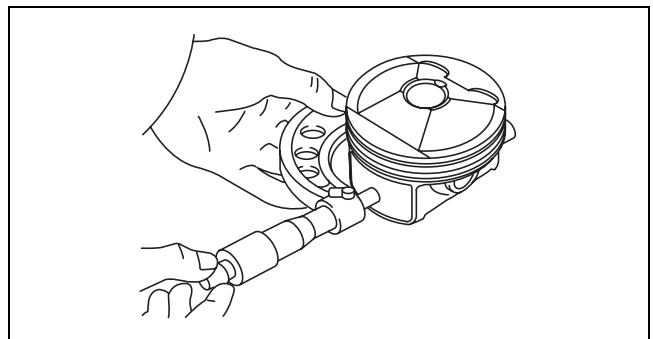

bpe2ue00000033

- Calculate the cylinder-to-piston clearance from the cylinder bore diameter and the piston outer diameter.
 - If the clearance exceeds the maximum specification, replace the piston or cylinder block.

Standard clearance between piston and cylinder
0.025—0.045 mm {0.0010—0.0017 in}

Maximum clearance between piston and cylinder
0.063 mm {0.0025 in}

- Measure the piston-to-ring groove clearance along the perimeter using a feeler gauge. For the O-ring, measure the clearance with the O-ring assembled to the piston.
 - If the clearance exceeds the maximum specification, replace the piston or piston ring.

Standard clearance between piston ring and ring groove
Top: 0.04—0.08 mm {0.002—0.003 in}
Second: 0.03—0.07 mm {0.0012—0.0027 in}
Oil: 0.04—0.12 mm {0.002—0.004 in}

Maximum clearance between piston ring and ring groove
Top: 0.12 mm {0.0047 in}
Second: 0.10 mm {0.0039 in}
Oil: 0.17 mm {0.0067 in}

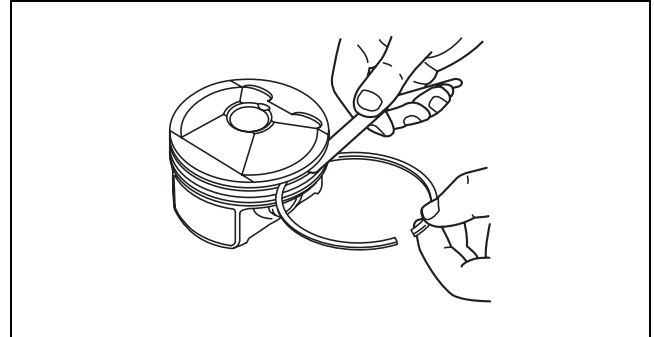

bpe2ue00000034

PISTON RING INSPECTION

- Using the piston, press the piston ring parallel into the cylinder to **43.9 mm {1.73 in}** from the upper end of the cylinder block.

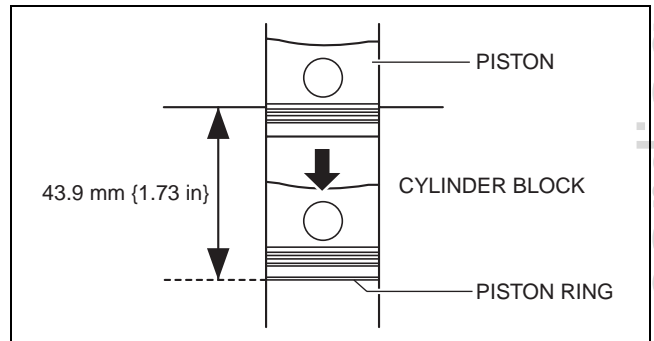

id011000592300

bpe2ue00000094

- Measure the piston ring end gap using a feeler gauge.
 - If it exceeds the maximum specification, replace the piston ring.

Standard piston ring end gap
Top: 0.13—0.18 mm {0.0052—0.0070 in}
Second: 0.18—0.28 mm {0.008—0.011 in}
Oil: 0.10—0.35 mm {0.004—0.013 in}

Maximum piston ring end gap
Top: 0.35 mm {0.014 in}
Second: 0.45 mm {0.018 in}
Oil: 0.52 mm {0.020 in}

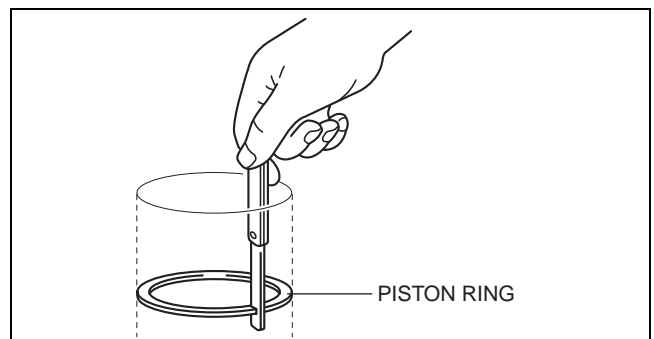

bpe2ue00000095

PISTON PIN INSPECTION

id011000507500

Caution

- If the piston or piston pin is replaced, replace the piston, piston pin and the snap ring as a single component.

1. Measure the piston pin outer diameter using the micrometer. Measurement positions total eight and are in the X and Y directions, at four points (A, B, C, and D) as shown in the figure.

Standard piston pin outer diameter
20.995—21.000 mm {0.82658—0.82677 in}

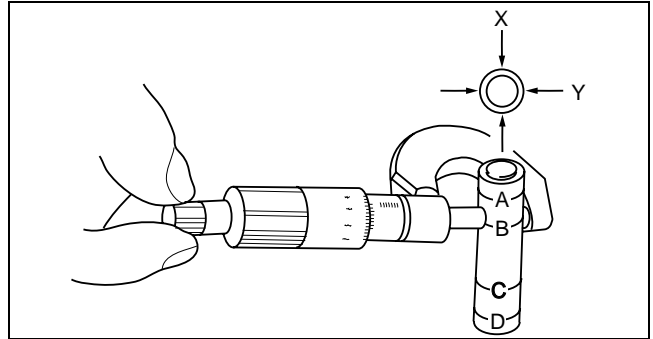

adj2224e255

2. Measure the piston pin hole diameter using the caliper gauge. Measurement positions total eight and are in the X and Y directions, at four points (A, B, C, and D) as shown in the figure.

Standard piston pin hole diameter
21.004—21.008 mm {0.82693—0.82708 in}

3. Calculate the clearance between the piston pin hole diameter and the piston pin outer diameter.
 - If it is not within the specification, replace the piston or the piston pin.

Standard clearance between piston pin hole diameter and piston pin outer diameter
0.004—0.013 mm {0.0002—0.0005 in}

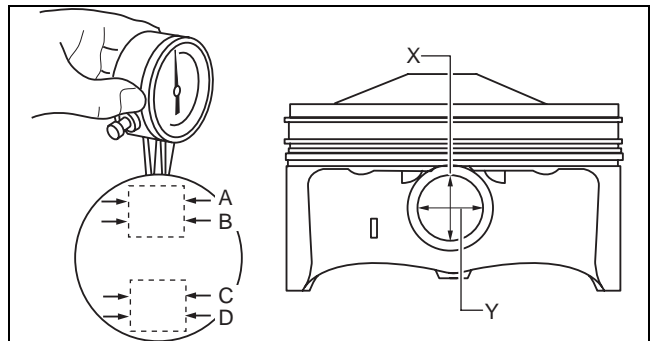

bpe2ue0000091

4. Measure the inner diameter on the small end of the connecting rod using the caliper gauge in the X and Y directions as shown in the figure.

Standard connecting rod small end inner diameter
21.006—21.017 mm {0.82701—0.82744 in}

5. Calculate the clearance between the inner diameter on the small end of the connecting rod and the piston pin outer diameter.
 - If it is not within the specification, replace the connecting rod or the piston pin.

Standard clearance between connecting rod small end inner diameter and piston pin outer diameter
0.006—0.022 mm {0.0003—0.0008 in}

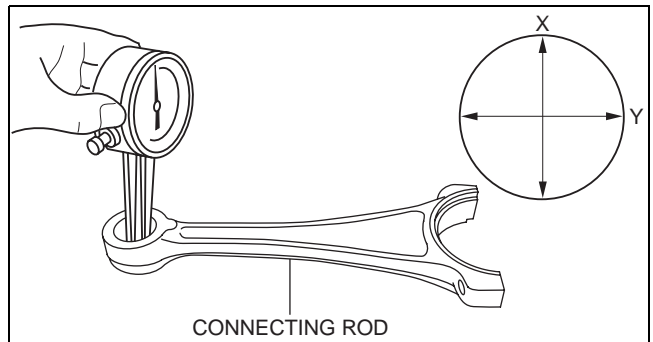

bpe2ue0000092

PISTON AND CONNECTING ROD INSPECTION

1. Check the oscillation torque as shown in the figure. Verify that the large end drops under its own weight with no resistance.
 - If the piston shakes heavily or unsmoothly, disassemble the piston and connecting rod, then inspect the following: (See 01-10-32 PISTON PIN INSPECTION.)
 - Clearance between piston pin outer diameter and piston pin hole diameter.
 - Clearance between piston pin outer diameter and connecting rod small end inner diameter.

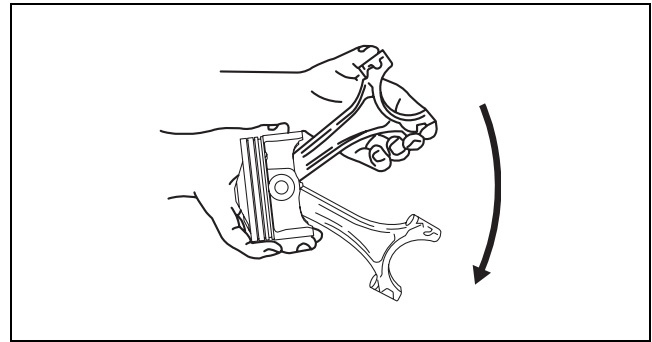

id011000503100

bp31je00000061

01-10

CONNECTING ROD INSPECTION

1. Inspect the connecting rod for bending and distortion using the connecting rod aligner.
 - If it exceeds the maximum specification, replace the connecting rod.

Maximum connecting rod bending
0.050 mm {0.0020 in}

Maximum connecting rod distortion
0.050 mm {0.0020 in}

Connecting rod center-to-center distance
155.2 mm {6.110 in}

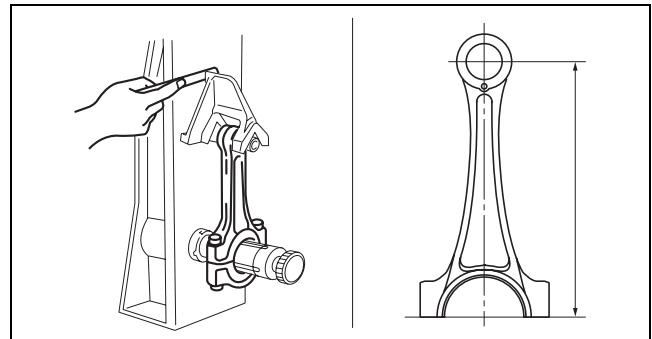

id011000502800

bpe2ue00000036

CONNECTING ROD CLEARANCE INSPECTION

1. Measure the side clearance at the large end of the connecting rod using a feeler gauge.
 - If it exceeds the maximum specification, replace the connecting rod or crankshaft.

Standard side clearance at the large end of connecting rod
0.14—0.36 mm {0.006—0.014 in}

Maximum side clearance at the large end of connecting rod
0.465 mm {0.0183 in}

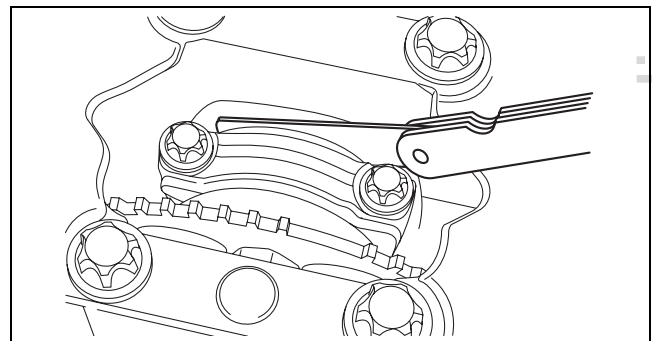

id011000507600

bp31je00000148

2. Measure the oil clearance at the large end of the connecting rod using the following procedure:
 - (1) Cut the plastigauge as wide as the connecting rod bearing width, place it parallel to the crankshaft, keeping away from the oil hole.
 - (2) Install the lower connecting rod bearing and connecting rod cap. (See 01-10-37 CYLINDER BLOCK ASSEMBLY (I).)
 - (3) Remove the connecting rod cap. (See 01-10-20 CYLINDER BLOCK DISASSEMBLY (II).)
 - (4) Measure the oil clearance at the large end of the connecting rod.
 - If it exceeds the maximum specification, replace the bearing or grind the crank pin and use oversize bearings so that the specified clearance is obtained.

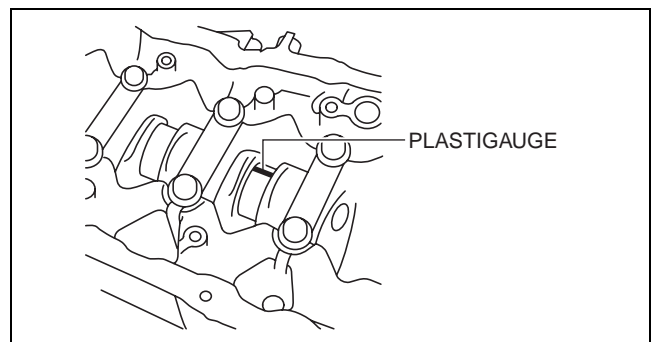

bpe2ue00000093

MECHANICAL

Standard bearing oil clearance at the large end of the connecting rod
0.026—0.052 mm {0.0011—0.0020 in}

Maximum bearing oil clearance at the large end of the connecting rod
0.10 mm {0.0039 in}

Connecting rod bearing size

STD: 1.503—1.520 mm {0.05918—0.05984 in}

OS 0.25: 1.628—1.631 mm {0.06410—0.06421 in}

OS 0.50: 1.753—1.756 mm {0.06902—0.06913 in}

CRANKSHAFT INSPECTION

id011000502500

1. Measure the crankshaft end play using a dial gauge.
 - If it exceeds the maximum specification, replace the crankshaft or grind the thrust side of crankshaft and use oversize thrust bearing so that the specified end play is obtained.

Standard crankshaft end play
0.08—0.29 mm {0.004—0.011 in}

Maximum crankshaft end play
0.30 mm {0.012 in}

Thrust bearing size

STD: 2.500—2.550 mm {0.0985—0.1003 in}

OS0.25: 2.625—2.675 mm {0.1034—0.1053 in}

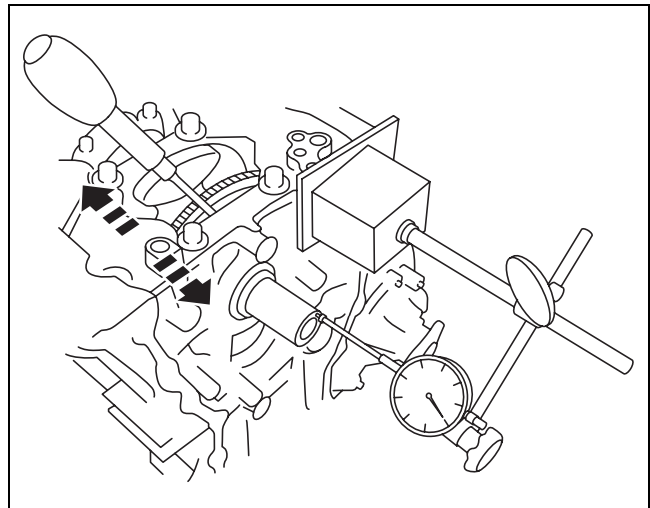

bp31je00000217

2. Measure the runout of the main journal using a V-block and dial gauge.
 - If it exceeds the maximum specification, replace the crankshaft.

Maximum main journal runout
0.10 mm {0.0039 in}

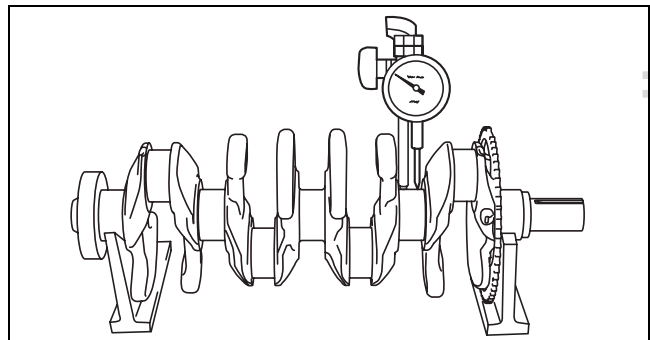

bpe2ue00000035

3. Inspect the main journal diameter and crank pin diameter. Measurement positions total four and are in the X and Y directions, at two points (A and B) as shown in the figure.
 - If it is not within the specification or if it exceeds the maximum off-round, grind the journal with an oversized bearing.

Standard main journal diameter
46.980—47.000 mm {1.8497—1.8503 in}

Maximum main journal off-round
0.005 mm {0.0002 in}

Standard crank pin diameter
46.980—47.000 mm {1.8497—1.8503 in}

Maximum crank pin off-round
0.005 mm {0.0002 in}

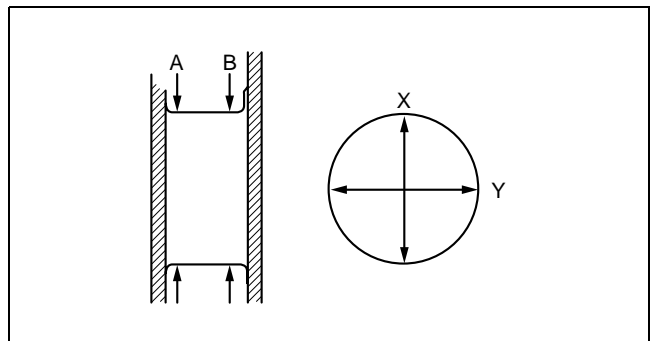

b3e0110e085

4. Inspect the main journal oil clearance using the following procedure:
 - (1) Install the thrust bearing, upper main bearing and crankshaft.
 - (2) Position a plastigauge on the journals.
 - (3) Install the lower main bearing and lower cylinder block. (See 01-10-37 CYLINDER BLOCK ASSEMBLY (I).)
 - (4) Remove the lower cylinder block. (See 01-10-20 CYLINDER BLOCK DISASSEMBLY (II).)
 - (5) Measure the main journal oil clearance.
 - If it exceeds the maximum specification, replace the main bearing, or grind the main journal and use oversized bearings so that the specified oil clearance is obtained.

Standard main journal oil clearance
0.016—0.039 mm {0.0007—0.0015 in}

Maximum main journal oil clearance
0.084 mm {0.0033 in}

Main bearing size
STD: 2.489—2.510 mm {0.0980—0.0988 in}
OS 0.25: 2.614—2.617 mm {0.10292—0.10303 in}
OS 0.50: 2.739—2.742 mm {0.10784—0.10795 in}

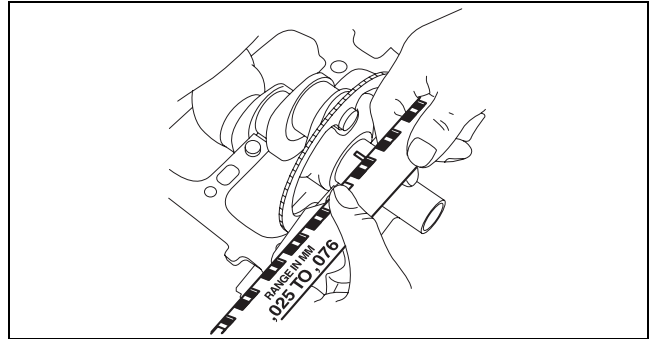

bp31je00000152

01-10

FLYWHEEL INSPECTION

id011000510200

1. Perform the following procedures to inspect the flywheel.
 - If there is any malfunction or it exceeds the maximum specification, replace the flywheel.
 - (1) Inspect the surface that contacts the clutch disc for scratches, nicks, and discoloration.
 - Correct slight scratches and discoloration using sandpaper.
 - (2) Inspect the ring gear teeth for damage and wear.

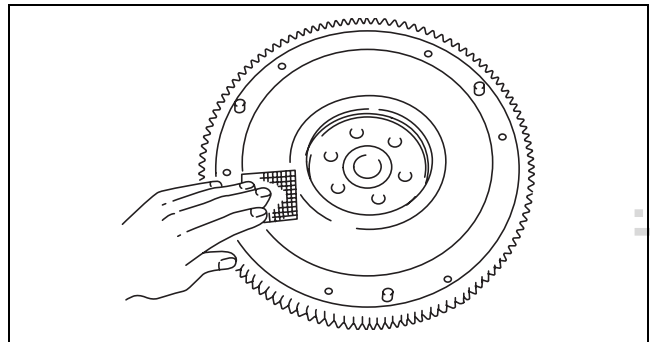

am3uuw00002076

- (3) Measure the runout of the surface that contacts the clutch disc using a dial gauge.

Flywheel maximum runout
0.10 mm {0.0039 in}

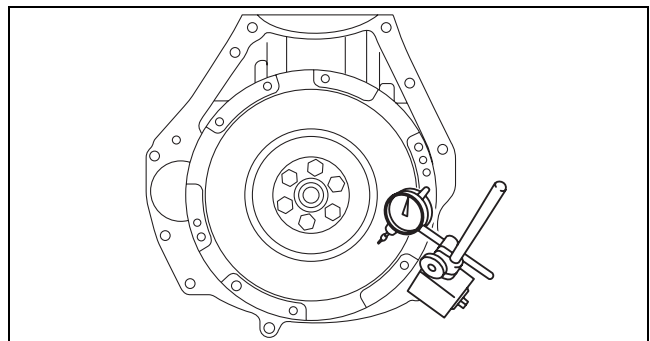

am3uuw00008268

PILOT BEARING INSPECTION

id011000505200

1. Without removing the pilot bearing, turn the bearing while applying force in the axial direction.
 - If there is any malfunction, replace the pilot bearing.

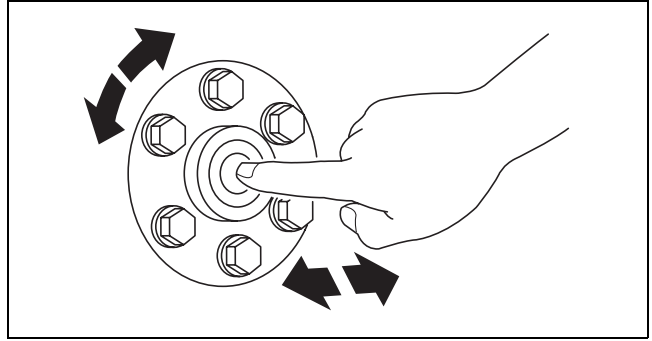

am3uuw00002078

BOLT INSPECTION

id011000503300

1. Measure the length of the each bolt.
 - If it exceeds the maximum specification, replace the bolt.

Standard cylinder head bolt length
145.2—145.8 mm {5.717—5.740 in}

Maximum cylinder head bolt length
146.5 mm {5.768 in}

Standard connecting rod bolt length
43.7—44.3 mm {1.73—1.74 in}

Maximum connecting rod bolt length
45.0 mm {1.77 in}

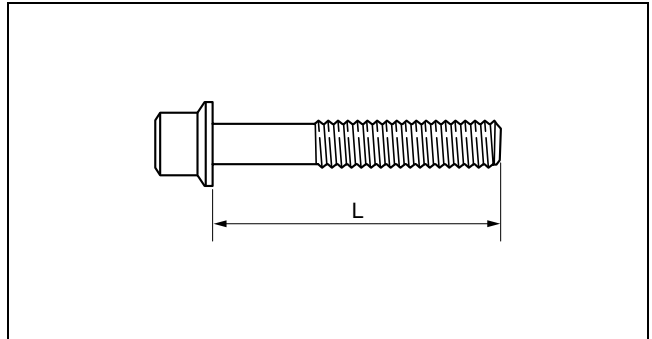

beltze00000026

MECHANICAL

CYLINDER BLOCK ASSEMBLY (I)

id011000504000

1. Assemble in the order indicated in the table.

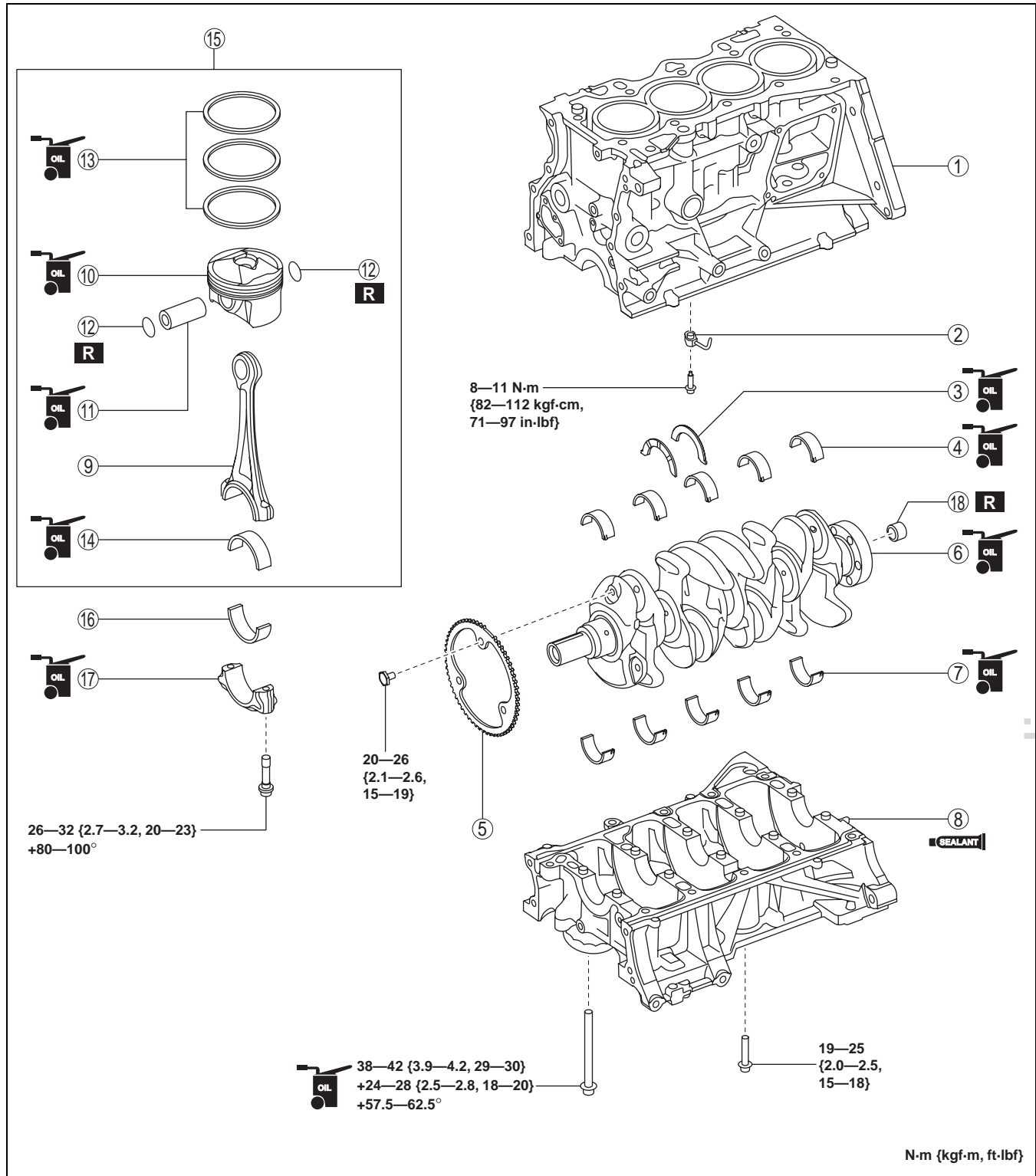

bpe2ue00000037

1	Upper cylinder block
2	Oil jet valve
3	Thrust bearing (See 01-10-38 Thrust Bearing And Main Bearing Assembly Note.)

4	Upper main bearing (See 01-10-38 Thrust Bearing And Main Bearing Assembly Note.)
5	Plate (See 01-10-38 Plate Assembly Note.)
6	Crankshaft

01-10

cardiagn.com

MECHANICAL

7	Lower main bearing (See 01-10-38 Thrust Bearing And Main Bearing Assembly Note.)
8	Lower cylinder block (See 01-10-39 Lower Cylinder Block Assembly Note.)
9	Connecting rod
10	Piston
11	Piston pin (See 01-10-40 Piston Pin Assembly Note.)
12	Snap ring (See 01-10-40 Snap Ring Assembly Note.)
13	Piston ring (See 01-10-41 Piston Ring Assembly Note.)

14	Upper connecting rod bearing (See 01-10-41 Connecting Rod Bearing Assembly Note.)
15	Piston, connecting rod (See 01-10-41 Piston, Connecting Rod Assembly Note.)
16	Lower connecting rod bearing (See 01-10-41 Connecting Rod Bearing Assembly Note.)
17	Connecting rod cap (See 01-10-42 Connecting Rod Cap Assembly Note.)
18	Pilot bearing (MTX) (See 01-10-42 Pilot Bearing Assembly Note.)

Thrust Bearing And Main Bearing Assembly Note

Caution

- If the thrust bearings and main bearings are reused, assemble the bearings to the same positions and in the direction as before removal to prevent engine damage due to seizure or burning of the bearing.
- To prevent engine damage due to seizure or burning of the bearing, apply engine oil to the sliding part when assembling.

Plate Assembly Note

Caution

- Placing the crankshaft on a disassembly bench will deform or damage it because the plate for the crankshaft position sensor signal detection installed to the crankshaft is larger than the counterweight. Therefore, set wood blocks or similar objects on the both sides of the crankshaft so that the plate does not contact the disassembly bench directly when placing the crankshaft on it bench.

1. Install the plate using the following procedure:
 - (1) Install the groove of the plate tooth to the position shown in the figure and temporarily tighten bolt A.
 - (2) Temporarily tighten the bolt B.
 - (3) Install bolt C and tighten the bolts to the specified tightening torque in the order of C, B, and A.

Tightening torque

20—26 N·m {2.1—2.6 kgf·m, 15—19 ft·lbf}

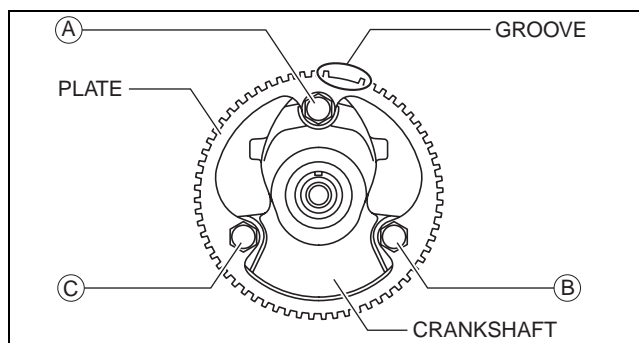

bpe2ue0000038

Lower Cylinder Block Assembly Note

1. Completely clean and remove any oil, dirt, sealant or other foreign material that may be adhering to the lower cylinder block and cylinder block.
2. When reusing the lower cylinder block installation bolts, clean any old sealant from the bolts.

Caution

- Apply silicon sealant in a single, unbroken line.
- To prevent silicon sealant from hardening, adhere the engine front cover and the cylinder block firmly within 10 min. after applying silicon sealant. After adhering them, tighten the installation bolts immediately.
- Using bolts with the old seal adhering could cause cracks in the cylinder block, etc.

3. Apply silicon sealant to the lower cylinder block shown in the figure.

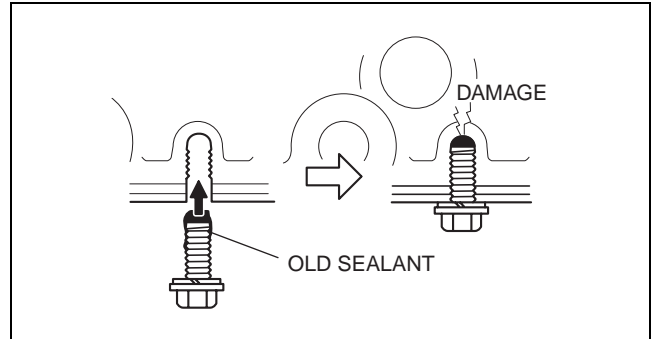

bpe2ue0000039

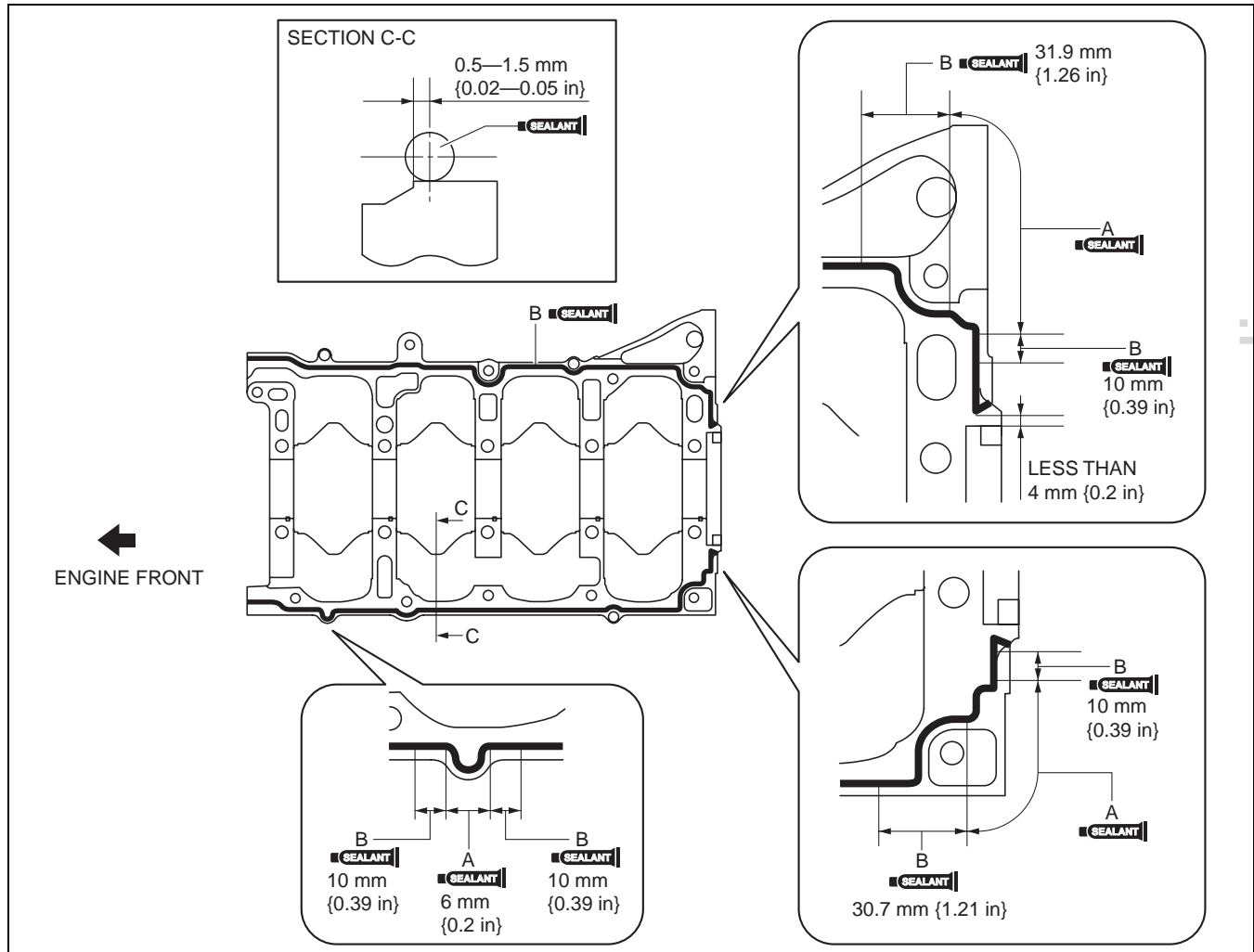

bpe2ue0000040

Bead thickness

- A: 3—7 mm {0.12—0.27 in}
 B: 2—6 mm {0.1—0.2 in}

MECHANICAL

4. Install the lower cylinder block.
5. Tighten the lower cylinder block installation bolts using the following procedure:
 - (1) Apply clean engine oil to seating surface and thread of the lower cylinder block installation bolts A.
 - (2) Tighten the lower cylinder block installation bolts A in the order shown in the figure using the following procedure:

Tightening procedure

1. 38—42 N·m {3.9—4.2 kgf·m, 29—30 ft·lbf}
2. Loosen all the bolts (until bolts are torque-free).
3. 24—28 N·m {2.5—2.8 kgf·m, 18—20 ft·lbf}
4. 57.5—62.5°

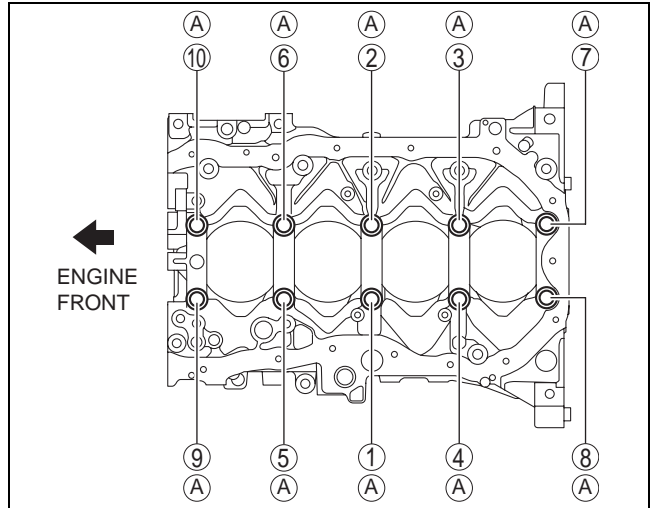

bpe2ue0000041

- (3) Tighten the lower cylinder block installation bolts B in the order shown in the figure.

Tightening torque

19—25 N·m {2.0—2.5 kgf·m, 15—18 ft·lbf}

6. After verifying that silicone sealant protrudes to the rear oil seal press-in part, wipe away the excess silicone sealant.
 - If silicone sealant does not protrude to the rear oil seal press-in part, remove the lower cylinder block and apply silicone sealant again.

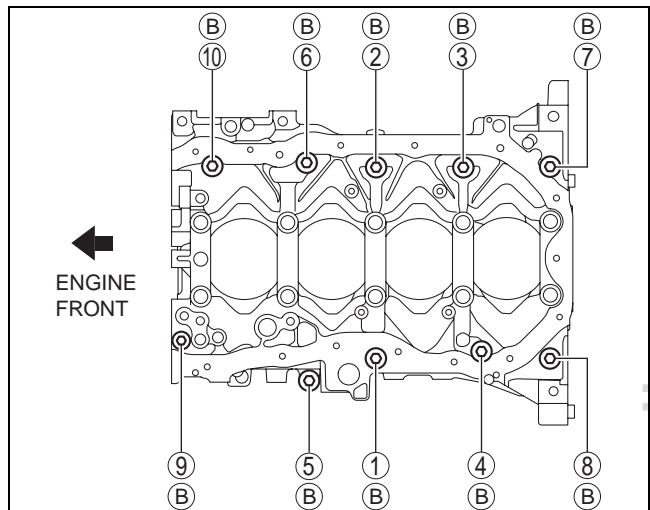

bpe2ue0000042

Piston Pin Assembly Note

1. Apply clean engine oil to the piston pin.
2. Insert the piston pin to the piston and connecting rod.

Note

- When assembling the piston to the connecting rod, each one can be assembled in either direction.

Snap Ring Assembly Note

Caution

- Do not compress the outer diameter of the snap ring more than necessary when assembling the snap ring (reference: 20.66 mm {0.8134 in} or less).

1. Insert a new snap ring using a thin plier.

Piston Ring Assembly Note

Note

- It is not required to position the end gap between the top ring and second ring.

- Assemble the piston ring so that the end gap of each oil ring does not overlap as shown in the figure.

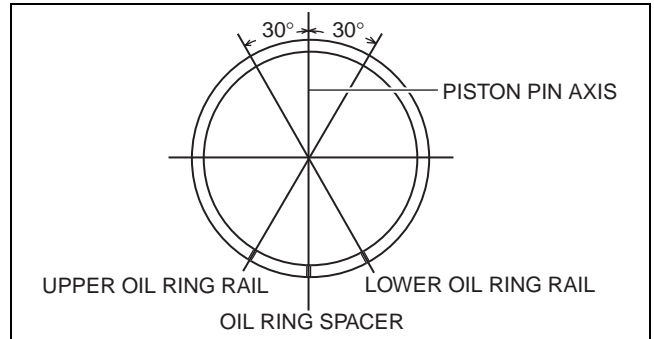

bpe2ue0000043

- Install the second ring with the notch facing downward.
- Install the top ring with the notch facing upward.

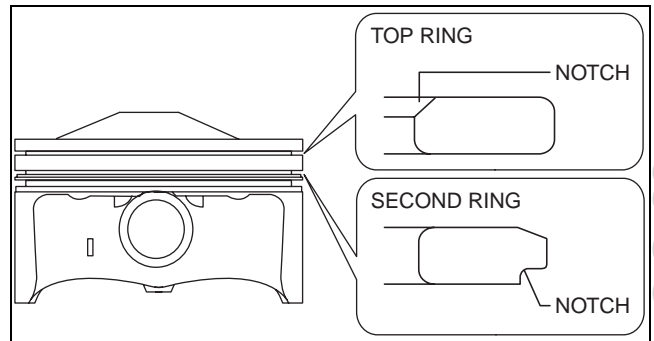

bpe2ue0000044

Connecting Rod Bearing Assembly Note

Caution

- If a connecting rod bearing is reused, assemble it to the same position and in the direction as before removal to prevent engine damage due to seizure or burning of the bearing.
- To prevent engine damage due to seizure or burning of the bearing, apply engine oil to the sliding part when assembling.

Piston, Connecting Rod Assembly Note

- Insert the piston into the cylinder with the mark on top of the piston facing the intake side.

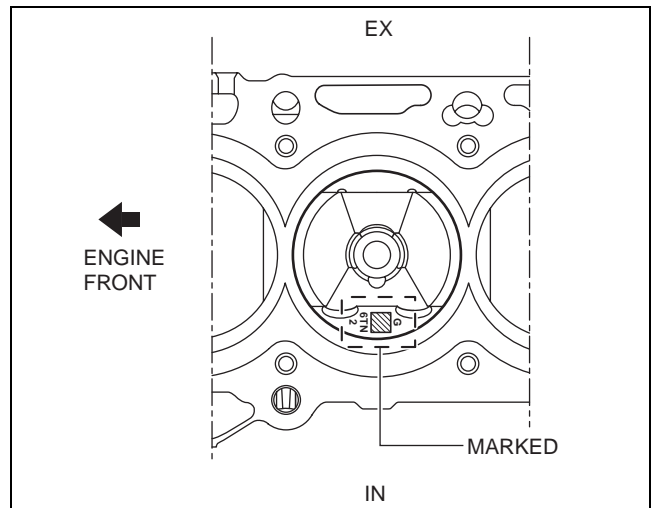

bpe2ue0000045

Connecting Rod Cap Assembly Note

Caution

- When assembling the connecting rod caps, align the broken, rough faces of the connecting rods and connecting rod caps.
- If the following condition is met, replace the connecting rod cap bolts.
 - Length exceeds maximum specification

Standard connecting rod cap bolt length
43.7—44.3 mm {1.73—1.74 in}

Maximum connecting rod cap bolt length
45.0 mm {1.77 in}

1. Position so that the broken, rough faces of the connecting rods and connecting rod caps are aligned exactly, and assemble the connecting rod caps.
2. Tighten the connecting rod cap bolts in the following two steps.

Tightening procedure

Step 1: 26—32 N·m {2.7—3.2 kgf·m, 20—23 ft·lbf}

Step 2: 80—100°

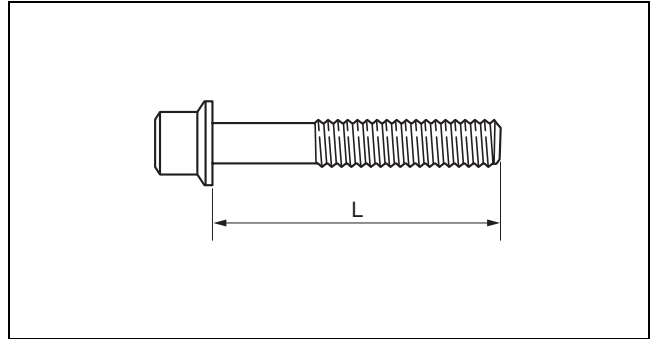

adejiw00001214

Pilot Bearing Assembly Note

1. Install new pilot bearing to the specified position using the following tools.

Tool

Snap-on brand millimeter size bushing driver set (A160M) adapter A160M7 (20—22 mm {0.79—0.86 in})

- Use the adapter with the 20 mm {0.79 in} side of the A160M7 (20—22 mm {0.79—0.86 in}) facing the pilot bearing side.

Substitution tool

Outer diameter: 21 mm {0.83 in}

Inner diameter: 19 mm {0.75 in}

Standard pilot bearing position

Distance A of pilot bearing from crankshaft end: 1.5—2.5 mm {0.060—0.098 in}

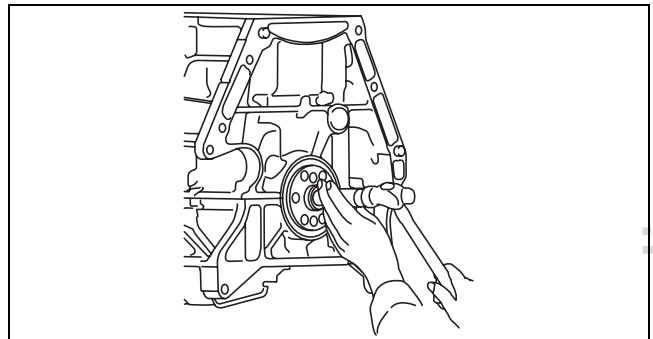

bpe2ue00000046

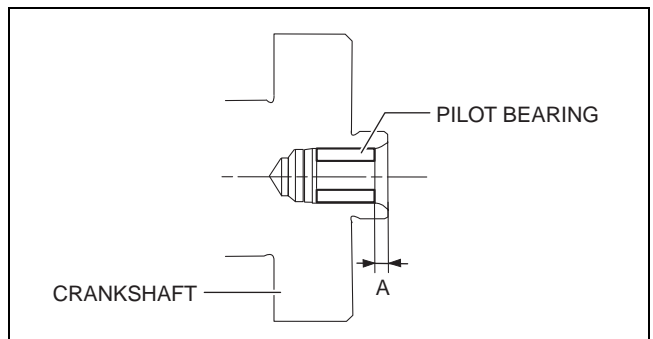

bpe2ue00000047

MECHANICAL

CYLINDER BLOCK ASSEMBLY (II)

id011000504100

1. Assemble in the order indicated in the table.

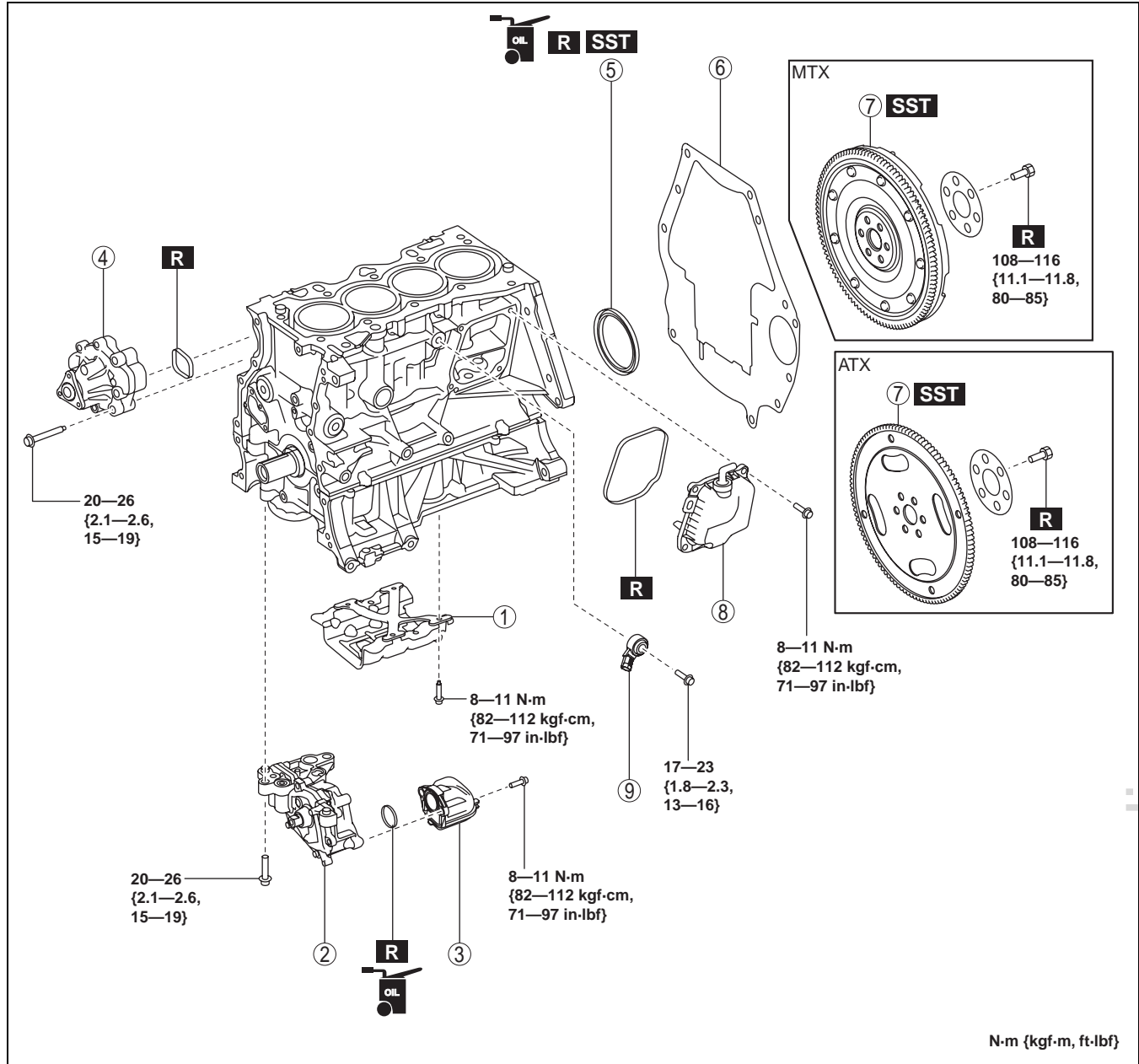

bpe2ue0000048

1	Oil baffle plate (See 01-10-44 Oil Baffle Plate Assembly Note.)
2	Oil pump (See 01-10-44 Oil Pump Assembly Note.)
3	Oil strainer
4	Water pump (See 01-10-45 Water Pump Assembly Note.)
5	Rear oil seal (See 01-10-46 Rear Oil Seal Assembly Note.)

6	End plate (See 01-10-47 End Plate Assembly Note.)
7	Flywheel (MTX), drive plate (ATX) (See 01-10-48 Flywheel (MTX), Drive Plate (ATX) Assembly Note.)
8	Oil separator
9	Knock sensor

01-10

MECHANICAL

Oil Baffle Plate Assembly Note

1. Tighten the bolts in the order shown in the figure.

Tightening torque

8—11 N·m {82—112 kgf·cm, 71—97 in·lbf}

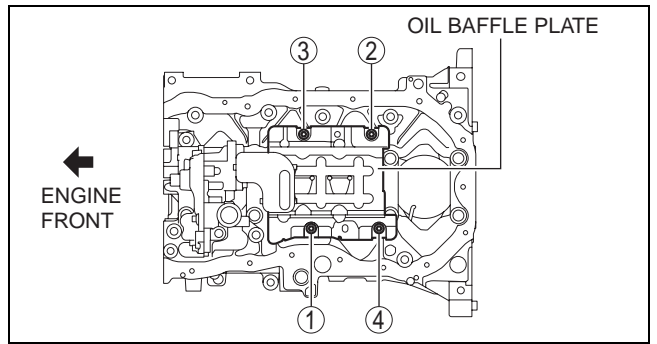

bpe2ue0000049

Oil Pump Assembly Note

1. Tighten the oil pump using the following procedure:
(1) Temporarily tighten the three bolts shown in the figure.

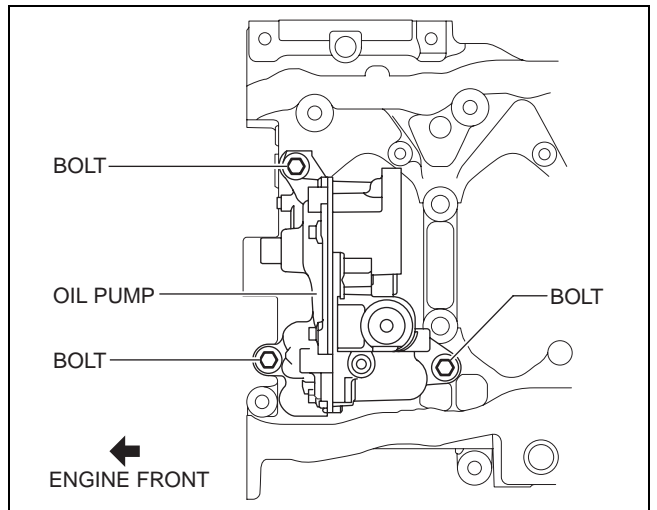

bpe2ue0000050

- (2) Tighten the two bolts shown in the figure to specified torque.
 - The tightening order for the two bolts is optional.

Tightening torque

20—26 N·m {2.1—2.6 kgf·m, 15—19 ft·lbf}

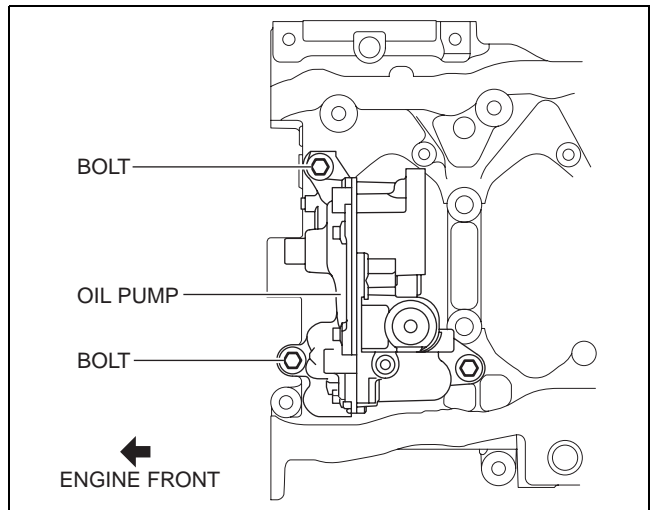

bpe2ue0000051

cardiagn.com

MECHANICAL

- (3) Finally, tighten the bolt shown in the figure to the specified torque.

Tightening torque

20—26 N·m {2.1—2.6 kgf·m, 15—19 ft·lbf}

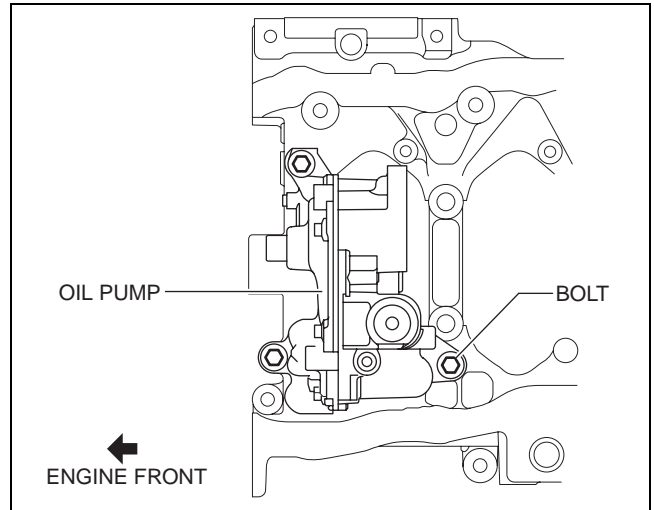

01-10

Water Pump Assembly Note

Caution

- Assemble the water pump gasket to the correct direction shown in the figure. Otherwise, it could leak engine coolant and damage the engine.

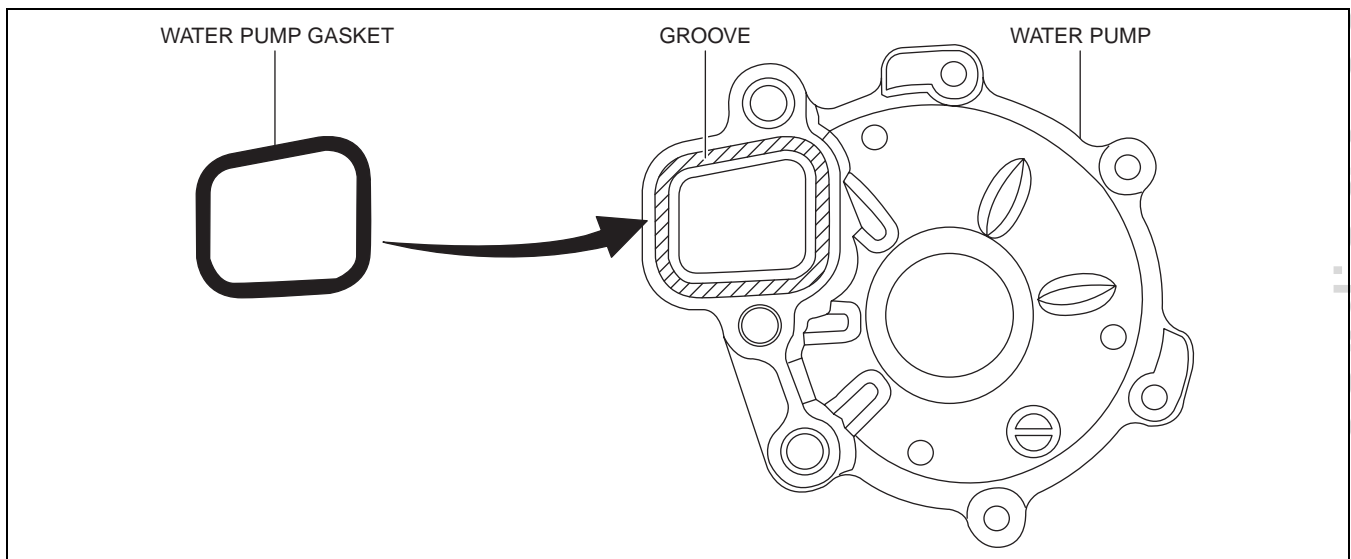

cardiagn.com

1. Insert a new water pump gasket into the water pump groove.
2. Install the water pump.

MECHANICAL

3. Tighten the bolts in the order shown in the figure.

Tightening torque

20—26 N·m {2.1—2.6 kgf·m, 15—19 ft·lbf}

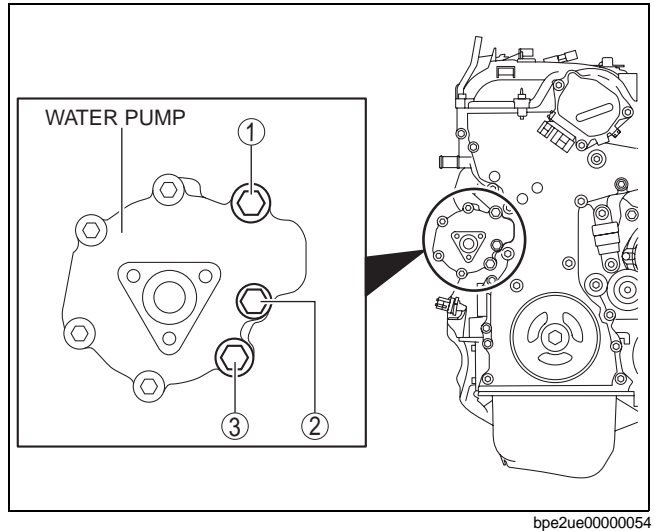

Rear Oil Seal Assembly Note

1. Apply clean engine oil to the inner surface of a new rear oil seal.
2. Insert the rear oil seal into the cylinder block by hand.
3. Tap the oil seal in evenly using the **SST** and a hammer.

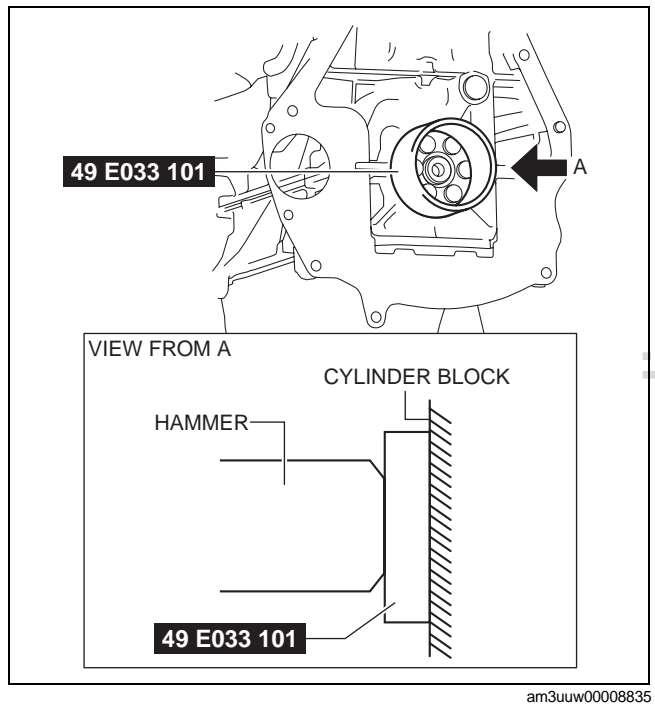

cardiagn.com

Rear oil seal press-in amount
 0—0.5 mm {0—0.019 in}

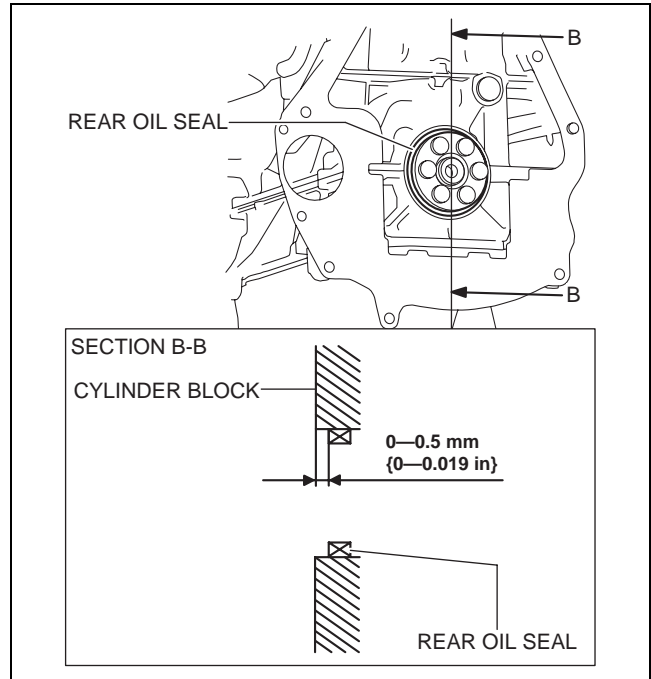

01-10

am3uuw00008836

End Plate Assembly Note

1. After end plate assembly, crimp the parts A and B shown in the figure.

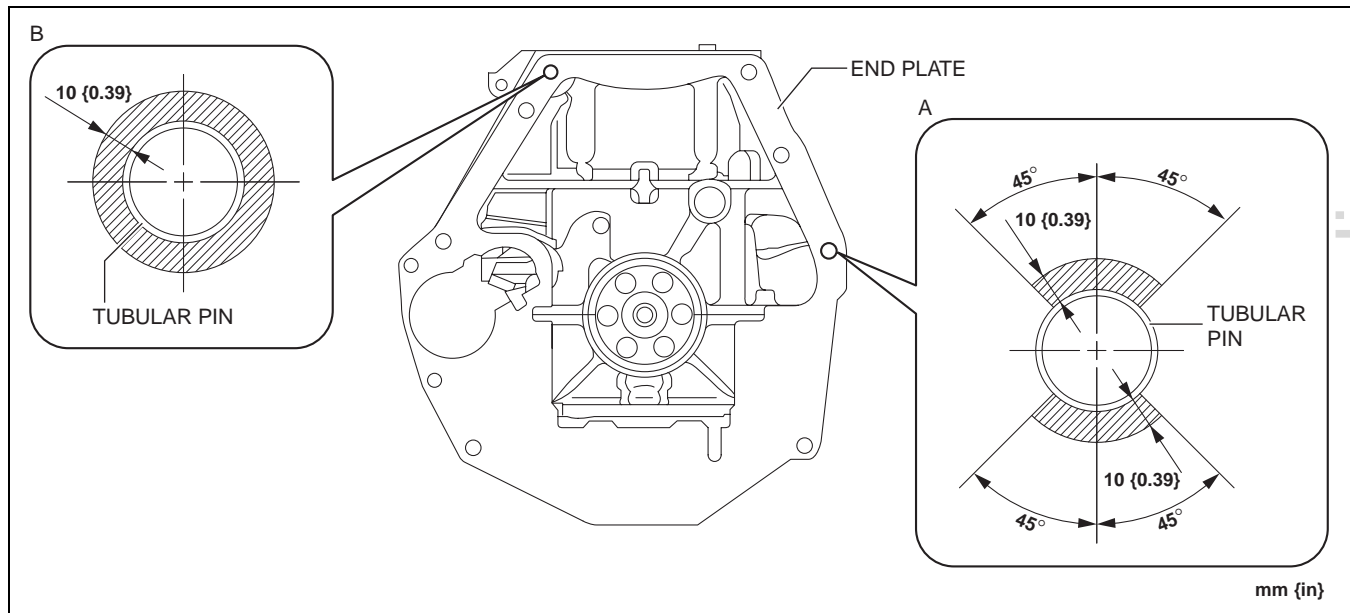

bpe2ue00000055

Crimp procedure

Crimp depth: 0.1—1.0 mm {0.004—0.039 in}

Crimp width: 0.5—10.0 mm {0.02—0.39 in}

Crimp locations: Part A is 1 or more on one-side within shaded area and part B is 2 or more within shaded areas

2. After crimping, verify that there is no damage and removal of the end plate.

MECHANICAL

Flywheel (MTX), Drive Plate (ATX) Assembly Note

1. Hold the crankshaft using the **SST**.
2. Tighten the new installation bolts in two or three passes in the order shown in the figure.

Tightening torque

108—116 N·m {11.1—11.8 kgf·m, 80—85 ft·lbf}

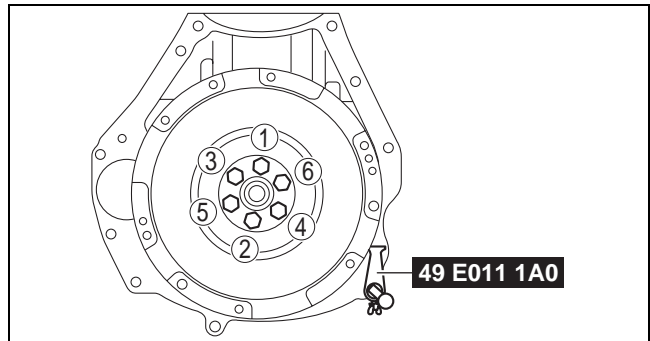

bpe2ue0000056

CYLINDER HEAD ASSEMBLY (I)

id011000504300

1. Assemble in the order indicated in the table.

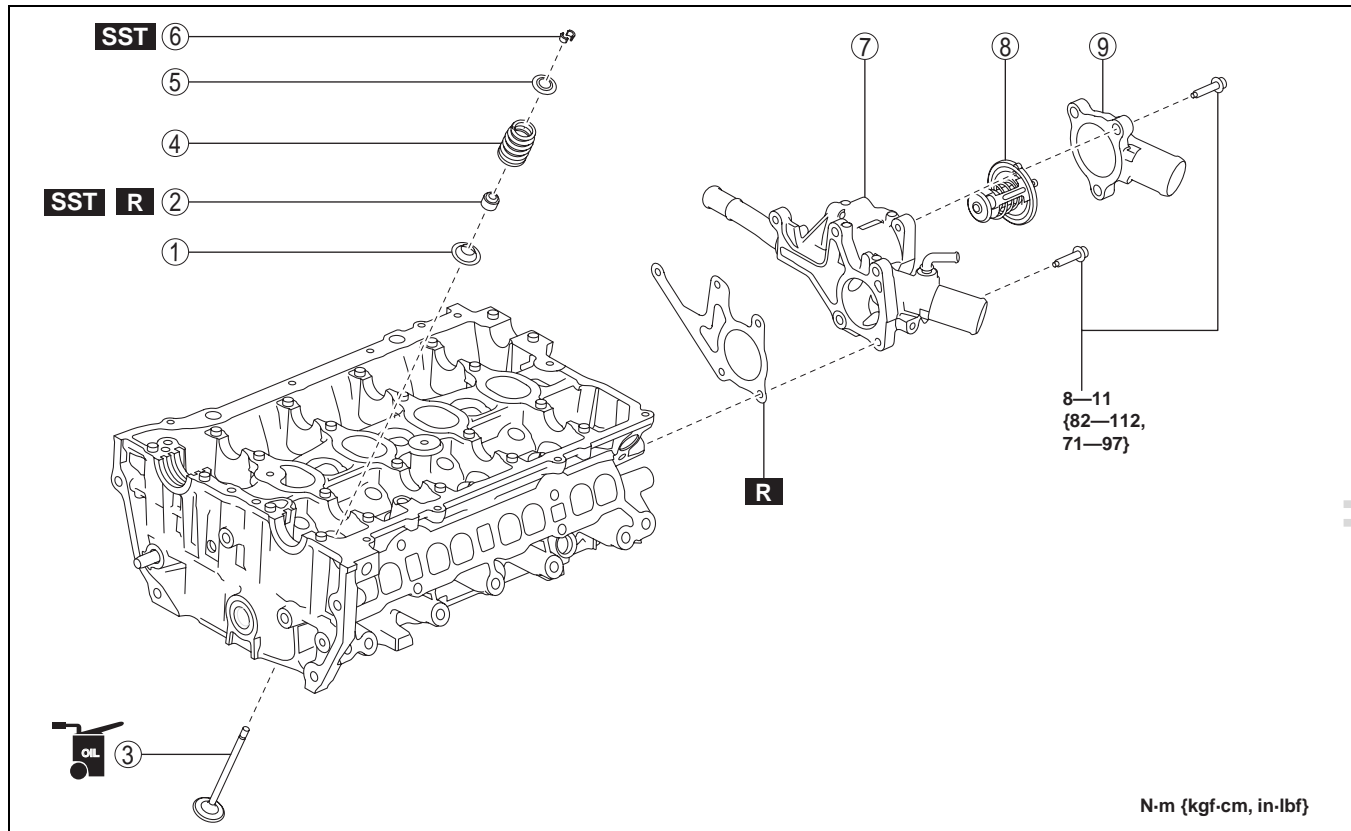

bpe2ue0000057

1	Lower valve spring seat
2	Valve seal (See 01-10-49 Valve Seal Assembly Note.)
3	Valve
4	Valve spring (See 01-10-49 Valve Spring Assembly Note.)
5	Upper valve spring seat

6	Valve keeper (See 01-10-49 Valve Keeper Assembly Note.)
7	Water outlet (See 01-10-50 Water Outlet Assembly Note.)
8	Thermostat (See 01-10-50 Thermostat Assembly Note.)
9	Thermostat cover

Valve Seal Assembly Note

1. Press in the valve seal to the valve guide using the **SST** by hand.

Valve seal identification color

IN: GREEN

EX: GRAY

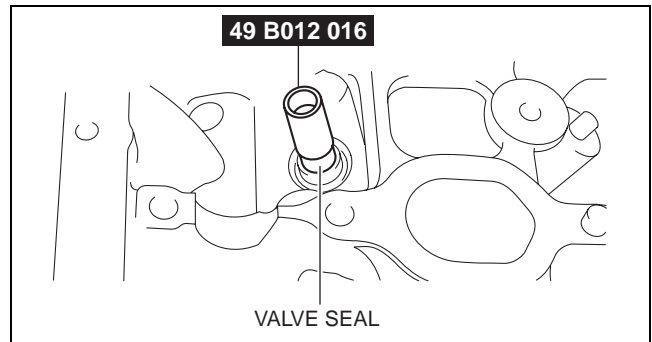

bpe2ue0000058

01-10

Valve Spring Assembly Note

Caution

- The valve springs differ depending on **IN** and **EX** sides. Therefore, verify the free length or identification paint beforehand and assemble the valve springs correctly.

1. Assemble the valve spring with the small diameter side of the valve spring facing upward.

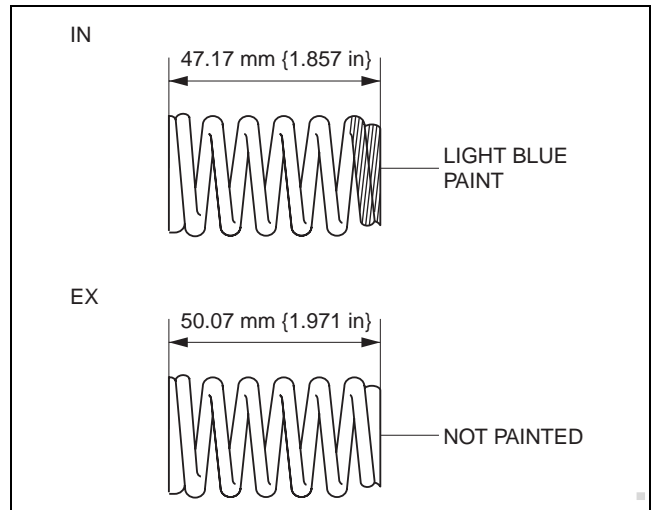

bpe2ue0000059

Valve Keeper Assembly Note

1. Install the valve keeper using the **SST**.

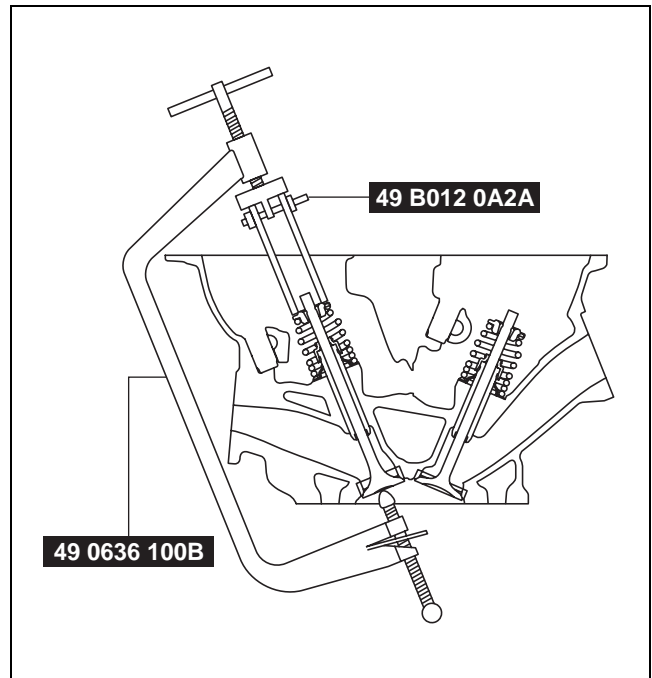

bpe2ue0000060

MECHANICAL

Water Outlet Assembly Note

1. Install the water outlet gasket with the bead of gasket facing the direction shown in the figure.
2. Temporarily tighten the water outlet installation bolts.

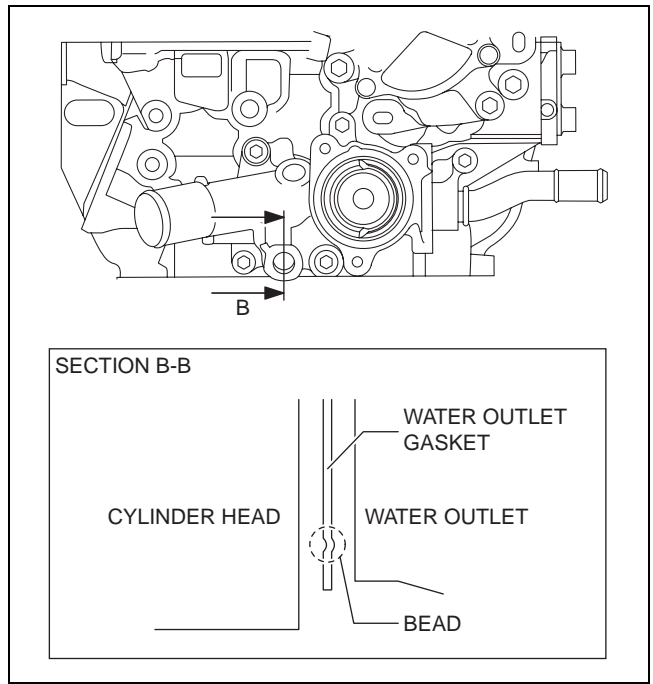

bpe2ue00000061

3. Tighten bolt A of the 5 bolts shown in the figure to the specified torque first.

Tightening torque

8—11 N·m {82—112 kgf·cm, 71—97 in·lbf}

Note

- The tightening order for the remaining 3 bolts is optional.

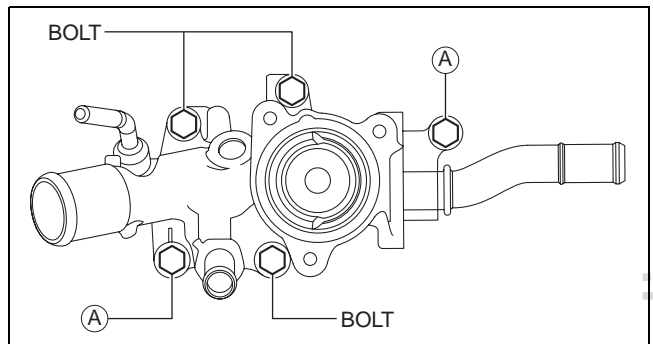

bpe2ue00000062

Thermostat Assembly Note

1. Install the thermostat with the jiggle pin aligned with the notch of the water outlet.

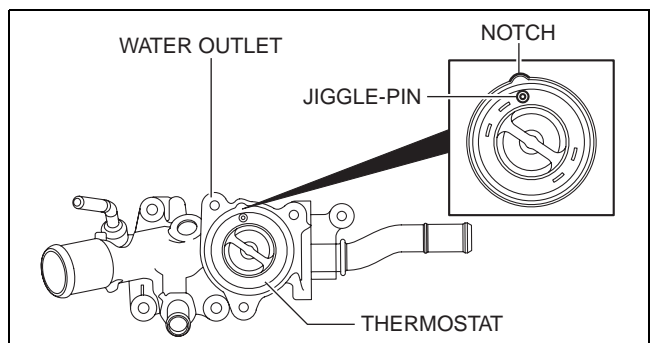

bpe2ue00000063

Caution

- If the camshaft is rotated with the timing chain removed and the piston at the top dead center position, the valve may contact the piston and the engine could be damaged. When rotating the camshaft with the timing chain removed, rotate it after lowering the piston from the top dead center position.
- When rotating the camshaft using a wrench on the cast hexagon, the wrench may contact the rocker arm and damage the rocker arm. To prevent damage to the rocker arm when holding the camshaft on the cast hexagon, use the wrench at engine rear side as shown in the figure to secure a clearance between the cam.

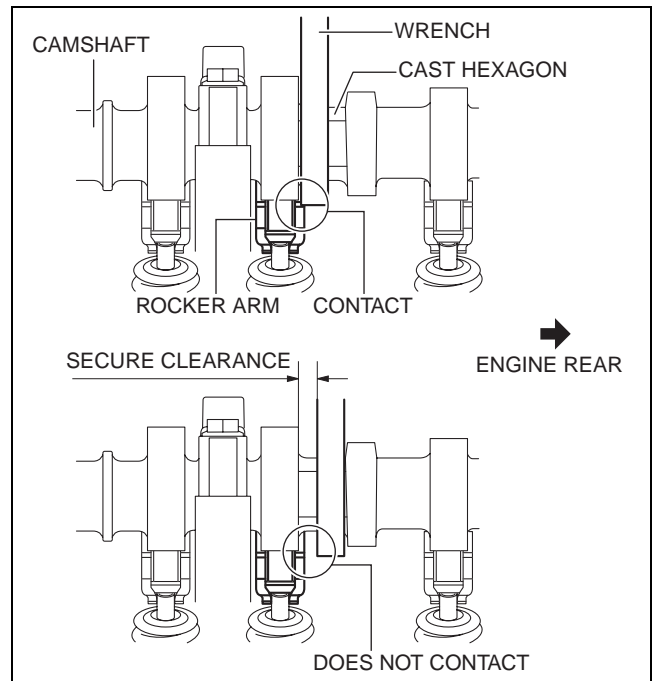

am3uuw00008968

Note

- Width at the cast hexagon of the camshaft is 22—24 mm {0.87—0.94 in}.

1. Assemble in the order indicated in the table.

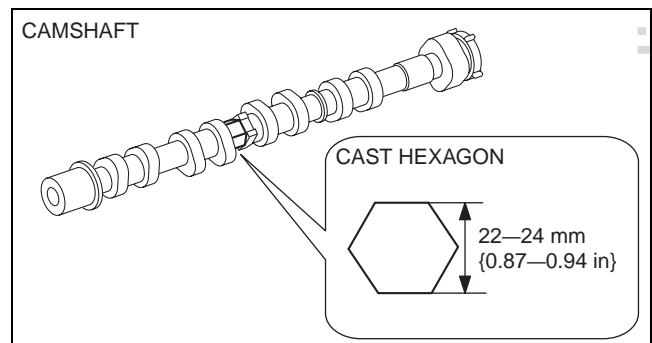

am3uuw00009029

MECHANICAL

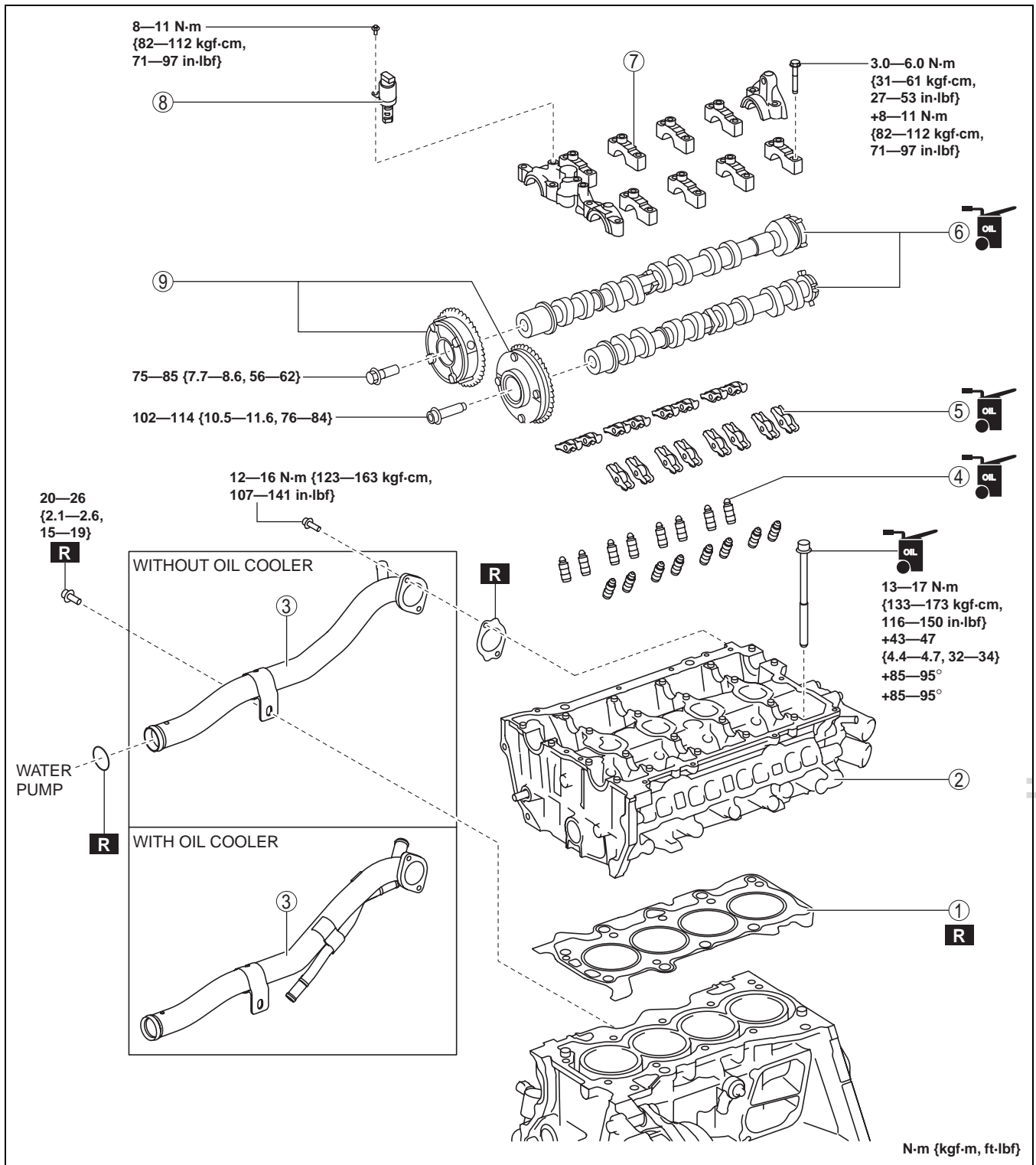

bpe2ue0000064

1	Cylinder head gasket
2	Cylinder head (See 01-10-53 Cylinder Head Assembly Note.)
3	Water inlet pipe (See 01-10-54 Water Inlet Pipe Assembly Note.)
4	HLA (See 01-10-55 HLA Assembly Note.)
5	Rocker arm (See 01-10-55 Rocker Arm Assembly Note.)

6	Camshaft (See 01-10-56 Camshaft Assembly Note.)
7	Camshaft cap (See 01-10-56 Camshaft Assembly Note.)
8	OCV
9	Electric variable valve timing actuator, hydraulic variable valve timing actuator (See 01-10-58 Electric Variable Valve Timing Actuator, Hydraulic Variable Valve Timing Actuator Assembly Note.)

Cylinder Head Assembly Note

Caution

- If the following condition is met, replace the cylinder head bolts.
 - Length exceeds maximum specification

Standard cylinder head bolt length L
145.2—145.8 mm {5.717—5.740 in}

Maximum cylinder head bolt length L
146.5 mm {5.767 in}

1. When a cylinder head bolt is reused, apply engine oil to any part of the following:
 - Bolt seating surface
 - Bolt thread
 - Cylinder head seating surface
2. Tighten the cylinder head bolts in the order shown in the following four steps.

Tightening procedure

Step 1: 13—17 N·m {133—173 kgf·cm, 116—150 in·lbf}

Step 2: 43—47 N·m {4.4—4.7 kgf·m, 32—34 ft·lbf}

Step 3: 85—95°

Step 4: 85—95°

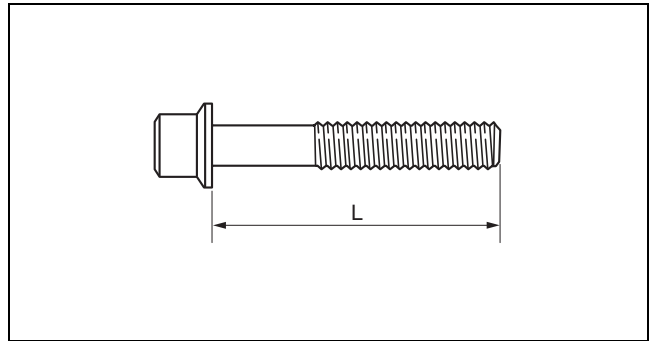

adeijw00001214

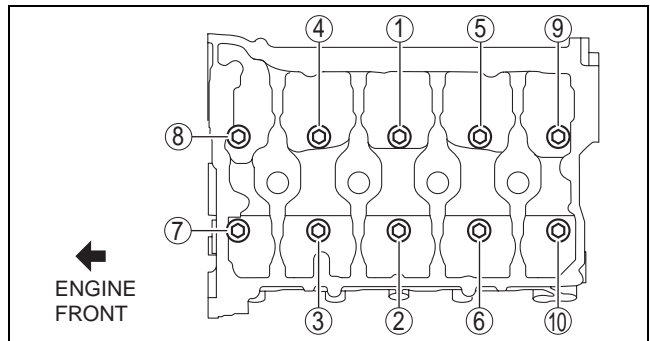

am3uuw00008818

01-10

cardiagn.com

MECHANICAL

Water Inlet Pipe Assembly Note

Caution

- Do not apply oil (engine oil, ATF etc.) to the O-ring of the water inlet pipe. Otherwise, the O-ring could swell causing a seal malfunction.

1. Clean away the sealant adhering to the bolt hole on the cylinder block side of the water inlet pipe stay.
2. Apply engine coolant to the O-ring.
3. Install the O-ring to the water inlet pipe.
4. Insert the water inlet pipe into the water pump being careful not to damage the O-ring.
5. Install the water inlet pipe gasket with the gasket projection facing the direction shown in the figure.

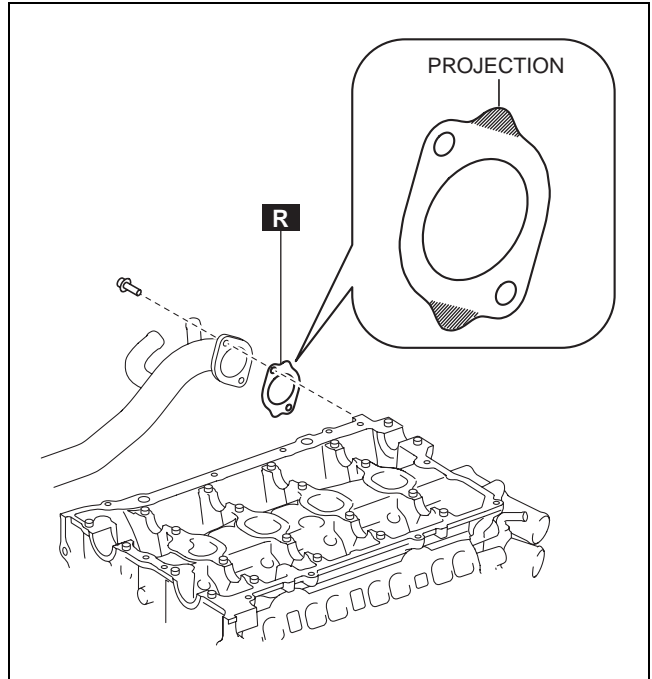

bpe2ue0000065

6. Tighten the bolts in the order shown in the figure.

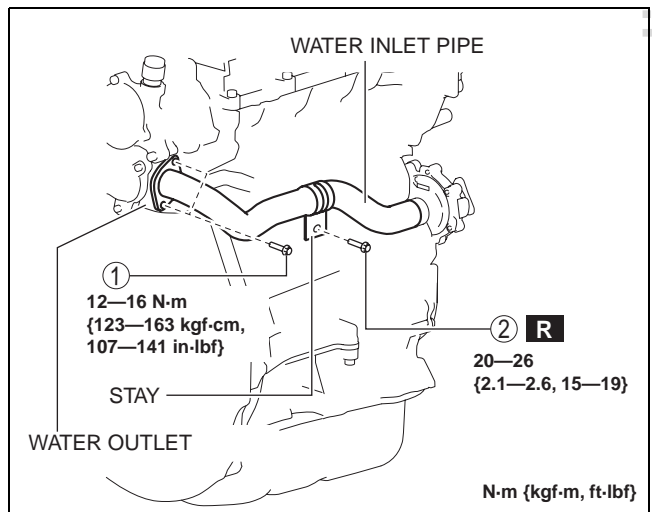

bpe2ue0000066

HLA Assembly Note

1. Perform HLA air bleeding using the following procedure:
 - (1) Put the HLA in a container filled with engine oil.

Caution

- Do not insert the round bar firmly because the check ball spring force is extremely weak.
- (2) While lightly pressing the check ball using a round bar (**approx. 1.0 mm {0.039 in}** diameter), bleed air by moving the plunger up and down.
 - (3) Press the end of the plunger in the oil and verify that there is no rebounding feel.
 - If rebounding feel cannot be eliminated, replace the HLA.
2. Install the HLAs to their original positions as before removal.

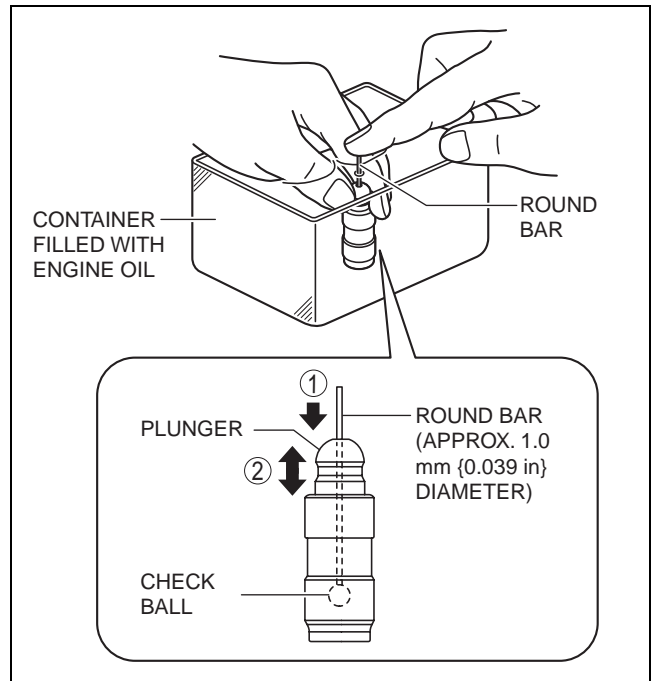

bpe2ue0000067

Rocker Arm Assembly Note

1. Apply engine oil to the HLAs and the end of the valve stems.
2. Install the rocker arms to their original positions as before removal.

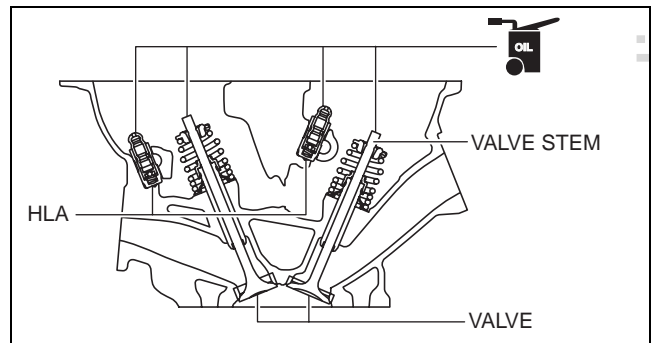

bpe2ue0000068

MECHANICAL

Camshaft Assembly Note

1. As shown in the figure, apply gear oil (SAE No. 90 or equivalent) or engine oil to the center area of each journal of the cylinder head.

Caution

- Apply 0.05 ml {0.05 cc, 0.003 in³} or less of oil to journal No.6.

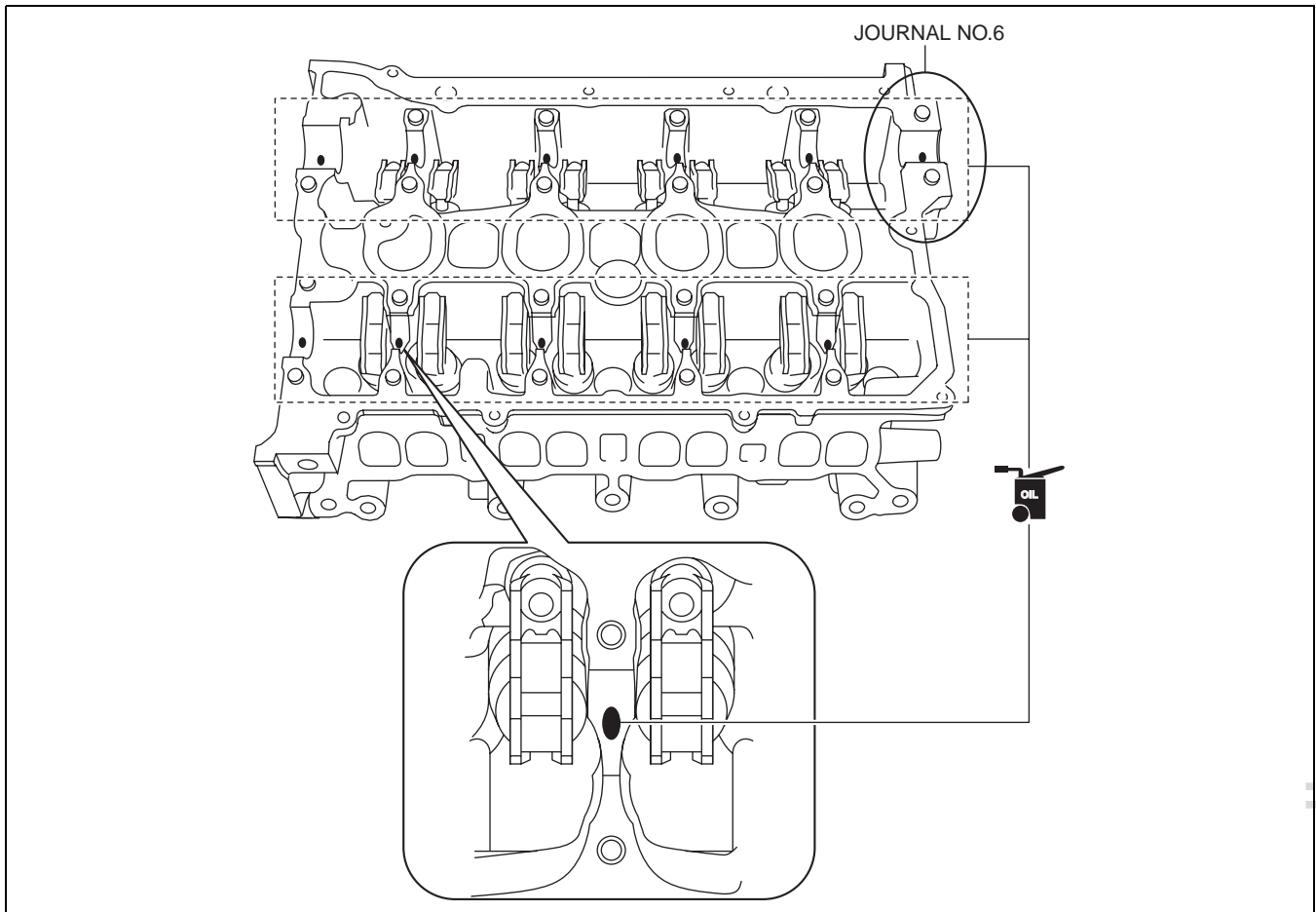

bpe2ue0000069

2. As shown in the figure, align the cam position of cylinder No.1 around top dead center (TDC) and place the camshafts on the cylinder head.

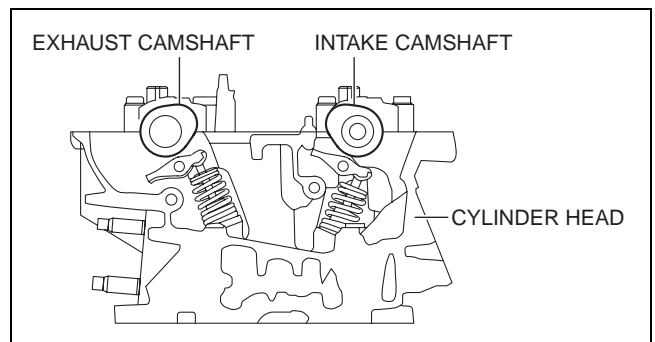

bpe2ue0000070

MECHANICAL

3. As shown in the figure, apply gear oil (SAE No. 90 or equivalent) or engine oil to the center area of each journal of the camshaft.

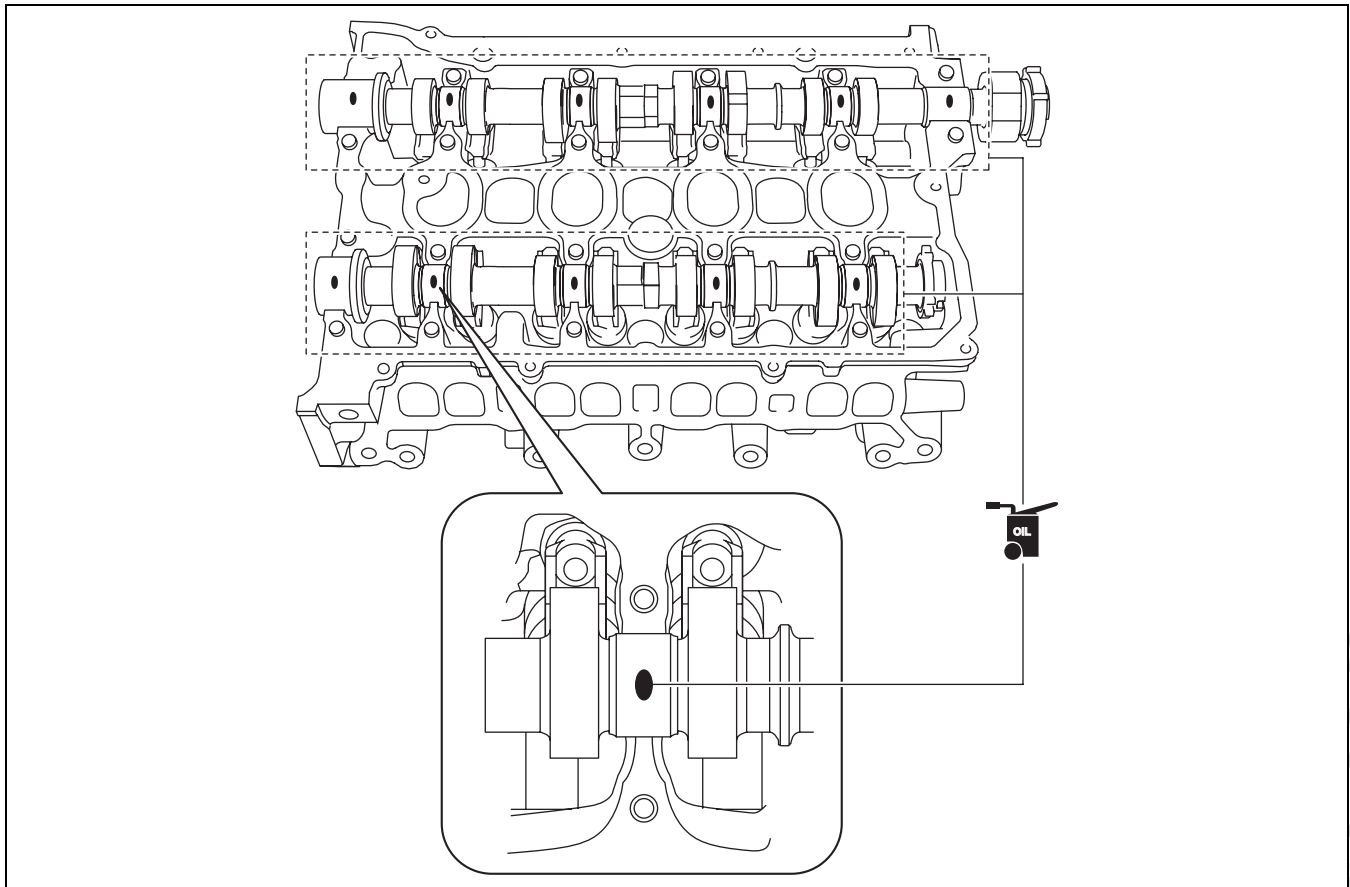

01-10

am3uuw00008994

4. Apply adhesive agent (Loctite 962T) around journal No.6 of the cylinder head or the exhaust-side rear camshaft cap.

Caution

- Verify that there is no adhesive agent on the journal.

Adhesive agent bead width
0.5—1.5 mm {0.02—0.05 in}

5. Install the camshaft caps in the marked number order, and temporarily tighten the camshaft cap installation bolts in two or three passes evenly.

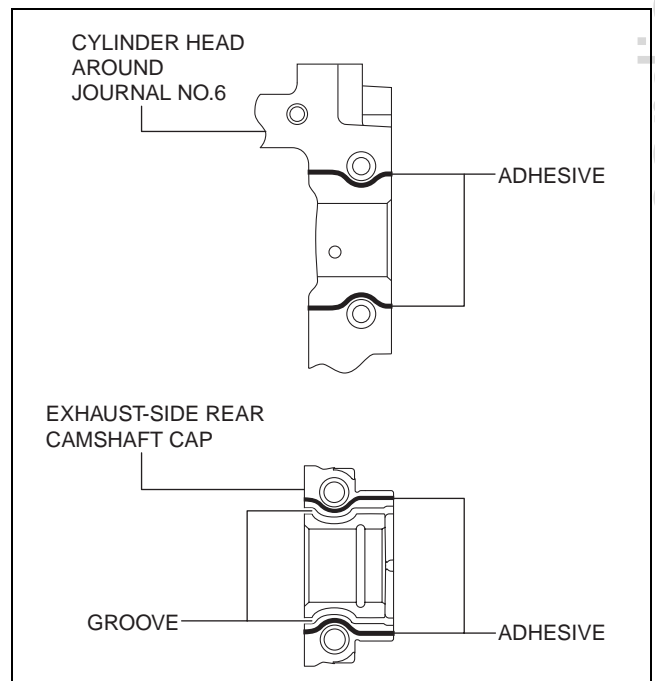

bpe2ue00000071

MECHANICAL

6. Tighten the camshaft cap installation bolts in two steps in the order shown in the figure.

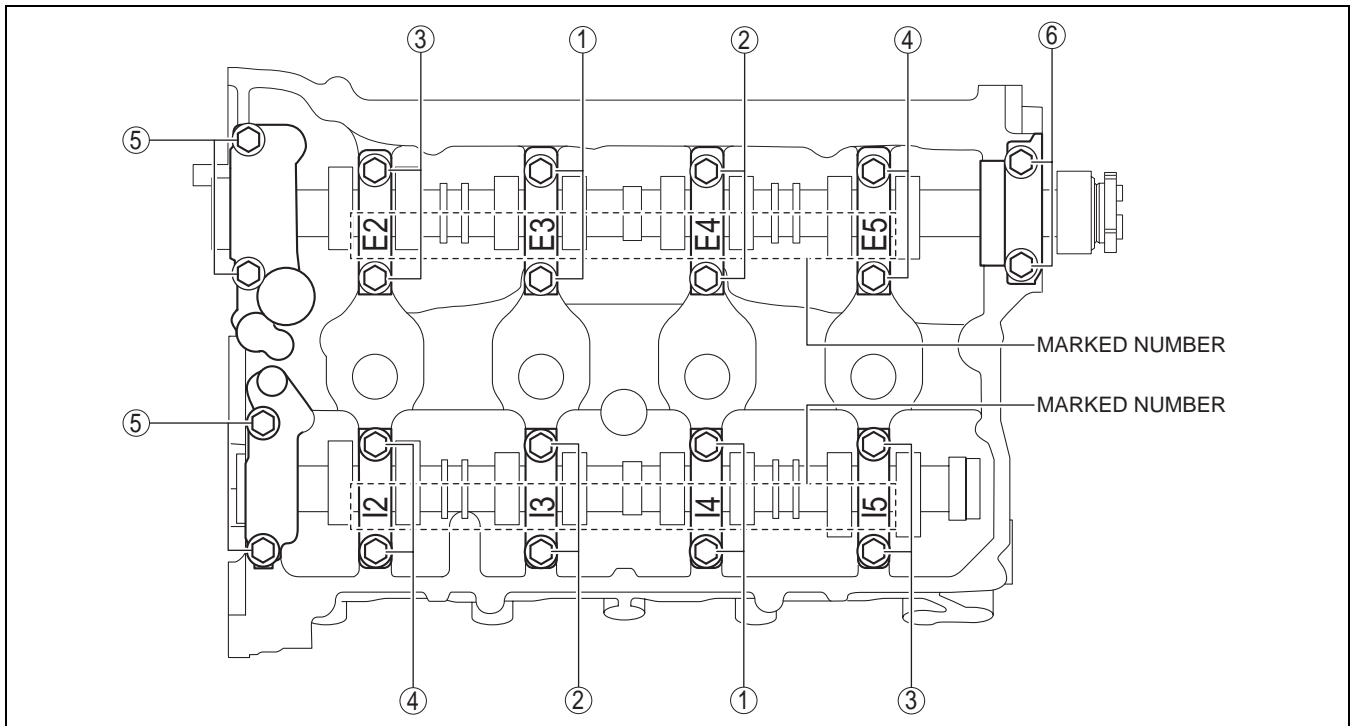

am3uuw00008996

Tightening torque

Step 1: 3.0—6.0 N·m {31—61 kgf·cm, 27—53 in·lbf}

Step 2: 8—11 N·m {82—112 kgf·cm, 71—97 in·lbf}

Electric Variable Valve Timing Actuator, Hydraulic Variable Valve Timing Actuator Assembly Note

1. Align the knock pin on the end of the camshaft with the notch on the actuator (intake side) or knock pin installation hole (exhaust side), then install the actuator to the camshaft.

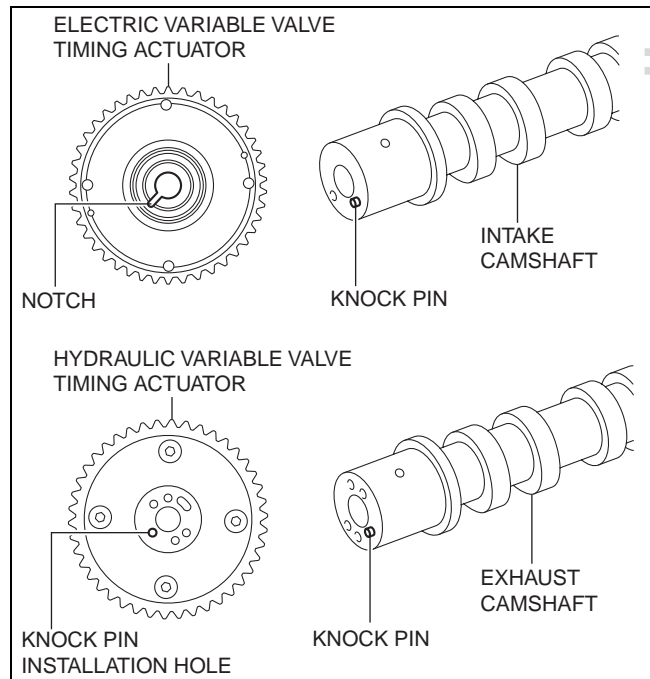

bpe2ue00000072

MECHANICAL

2. Hold the camshaft using a wrench on the cast hexagon, and tighten the actuator installation bolt.

Tightening torque

Electric variable valve timing actuator

(intake side): 102—114 N·m {10.5—11.6 kgf·m, 76—84 ft·lbf}

Hydraulic variable valve timing actuator

(exhaust side): 75—85 N·m {7.7—8.6 kgf·m, 56—62 ft·lbf}

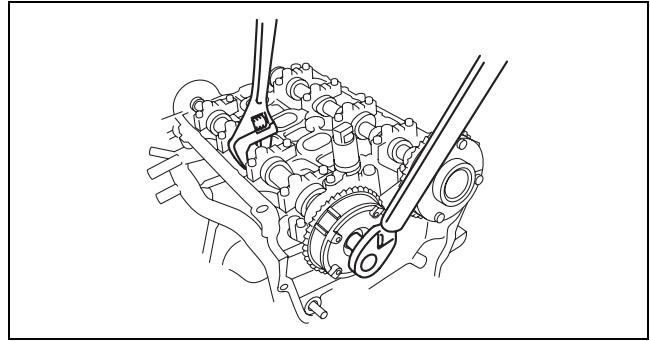

bpe2ue0000073

01-10

TIMING CHAIN ASSEMBLY

id011000505600

Caution

- If the camshaft is rotated with the timing chain removed and the piston at the top dead center position, the valve may contact the piston and the engine could be damaged. When rotating the camshaft with the timing chain removed, rotate it after lowering the piston from the top dead center position.
- When rotating the camshaft using a wrench on the cast hexagon, the wrench may contact the rocker arm and damage the rocker arm. To prevent damage to the rocker arm when holding the camshaft on the cast hexagon, use the wrench at engine rear side as shown in the figure to secure a clearance between the cam.

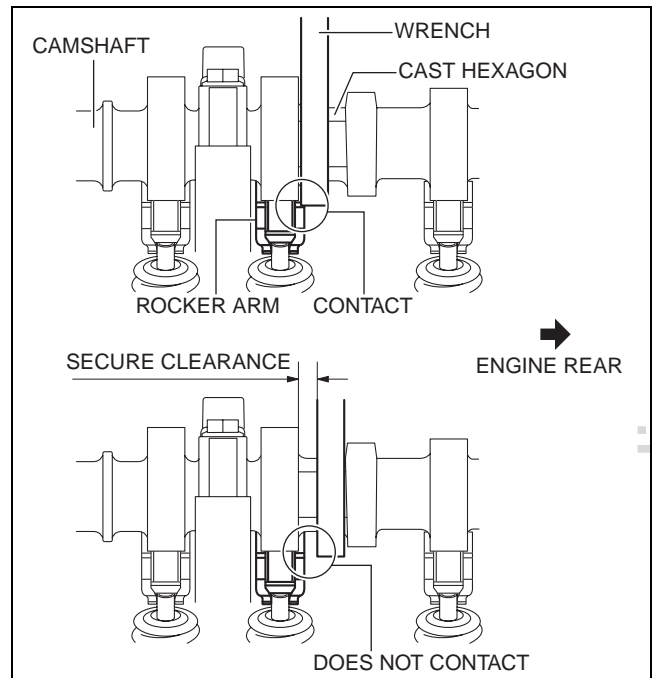

am3uuw00008968

Note

- Width at the cast hexagon of the camshaft is 22—24 mm {0.87—0.94 in}.

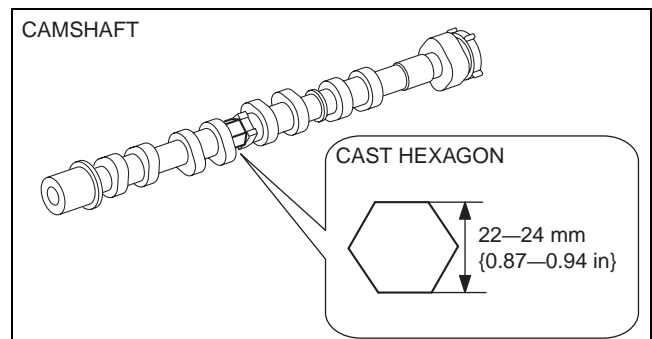

am3uuw00009029

MECHANICAL

1. Assemble in the order indicated in the table.

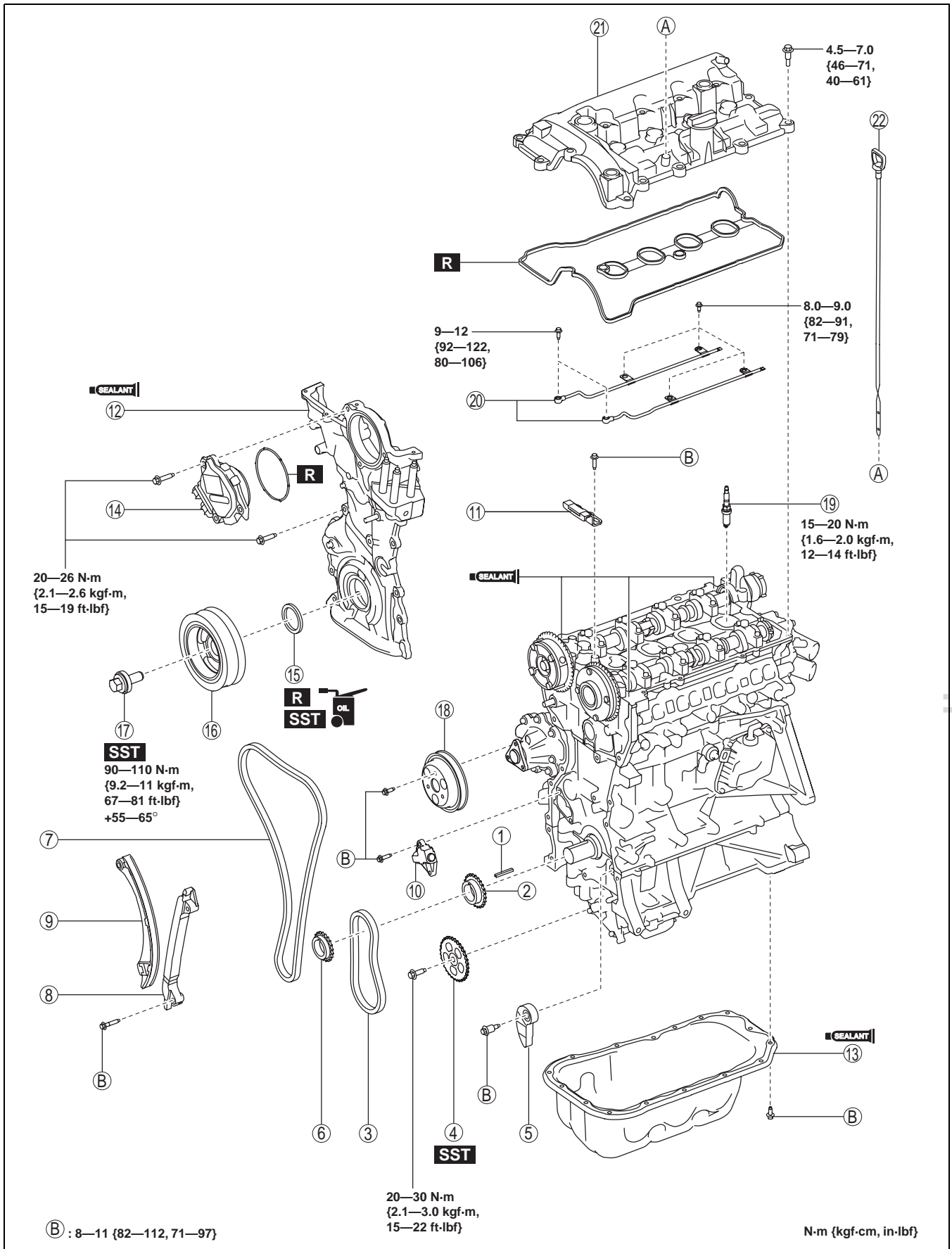

cardiagn.com

bpe2ue00000121

1	Key
---	-----

2	Oil pump drive sprocket
---	-------------------------

01-10-60

MECHANICAL

3	Oil pump chain
4	Oil pump driven sprocket (See 01-10-61 Oil Pump Driven Sprocket Assembly Note.)
5	Oil pump chain tensioner
6	Crankshaft sprocket
7	Timing chain (See 01-10-62 Timing Chain Assembly Note.)
8	Chain guide (No.2) (See 01-10-62 Timing Chain Assembly Note.)
9	Tensioner arm (See 01-10-62 Timing Chain Assembly Note.)
10	Chain tensioner (See 01-10-62 Timing Chain Assembly Note.)
11	Chain guide (No.1) (See 01-10-62 Timing Chain Assembly Note.)
12	Engine front cover (See 01-10-64 Engine Front Cover Assembly Note.)
13	Oil pan (See 01-10-68 Oil Pan Assembly Note.)

14	Electric variable valve timing motor/driver (See 01-10-69 Electric Variable Valve Timing Motor/Driver Assembly Note.)
15	Front oil seal (See 01-10-70 Front Oil Seal Assembly Note.)
16	Crankshaft pulley
17	Crankshaft pulley lock bolt (See 01-10-71 Crankshaft Pulley Lock Bolt Assembly Note.)
18	Water pump pulley (See 01-10-72 Water Pump Pulley Assembly Note.)
19	Spark plug
20	Oil shower pipe (See 01-10-73 Oil Shower Pipe Installation Note.)
21	Cylinder head cover (See 01-10-73 Cylinder Head Cover Installation Note.)
22	Dipstick

01-10

Oil Pump Driven Sprocket Assembly Note

1. Hold the crankshaft using the **SST**.
2. Install the oil pump driven sprocket.

Tightening torque

20—30 N·m {2.1—3.0 kgf·m, 15—22 ft·lbf}

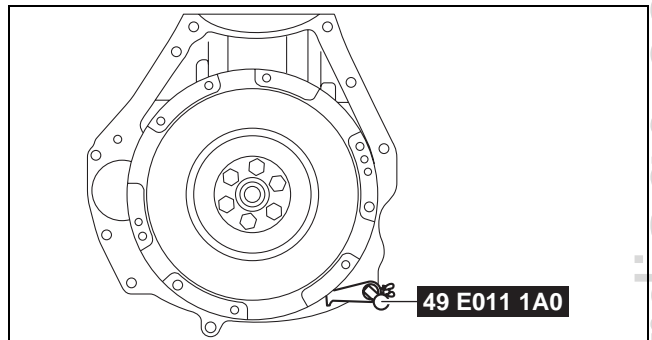

bpe2ue0000077

cardiagn.com

MECHANICAL

Timing Chain Assembly Note

1. Verify that the timing marks and the key are aligned to the position shown in the figure.

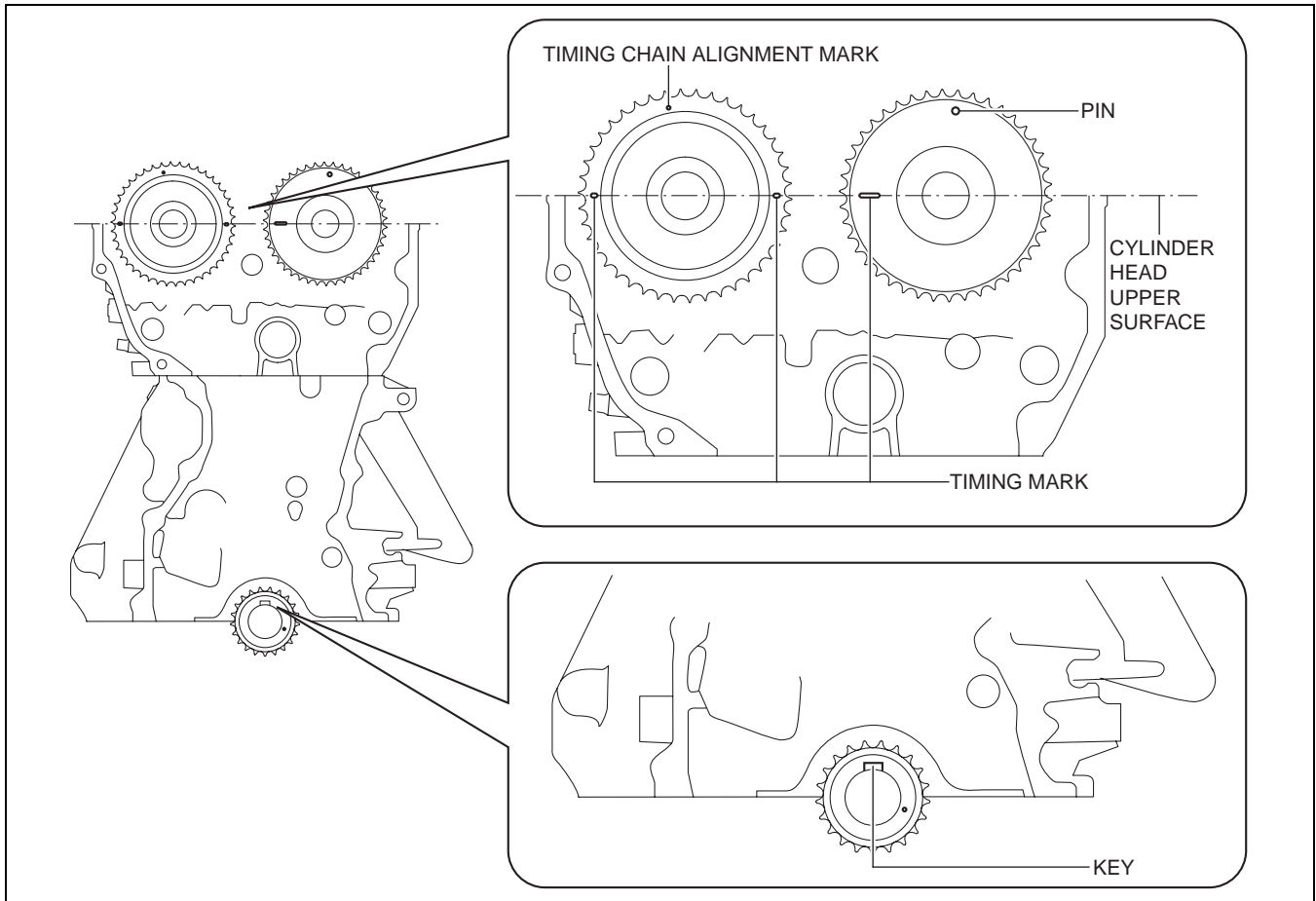

bpe2ue00000122

- If they are not in the position shown in the figure, rotate the camshaft and crankshaft to set the cylinder No.1 top dead center (TDC).

cardiagn.com

MECHANICAL

2. Install the timing chain while aligning the marks on each sprocket and the timing chain as shown in the figure.

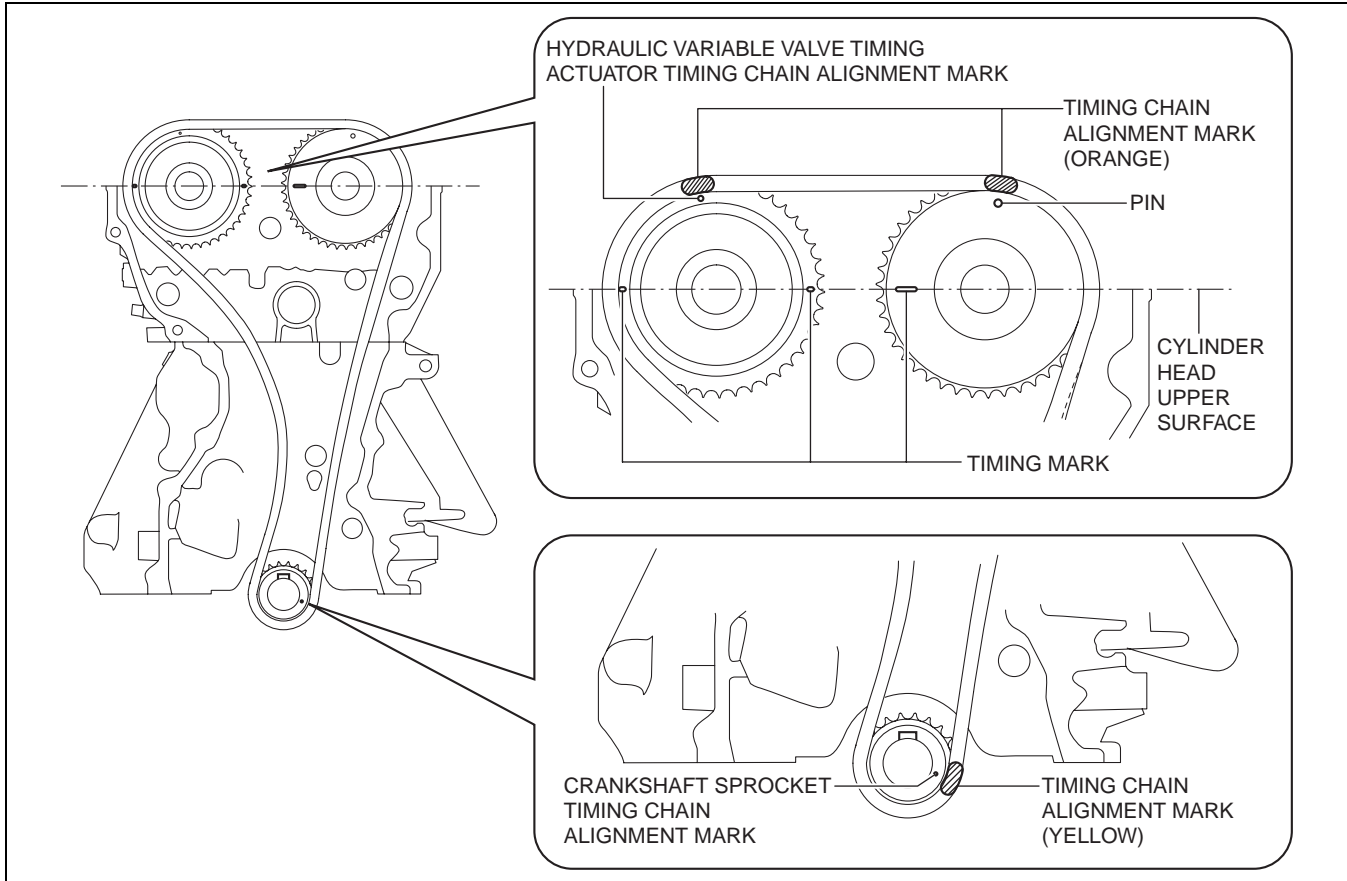

01-10

3. Install the chain guide (No.2).
4. Install the tensioner arm.
5. Install the chain tensioner.
6. After installing the chain tensioner, remove the installed wire or paper clip, and then apply tension to the timing chain.
 - If a new chain tensioner is used, remove the installed stopper.
7. Install the chain guide (No.1).
8. Verify that there is no looseness in the timing chain, and re-verify that each sprocket is in the specified location.

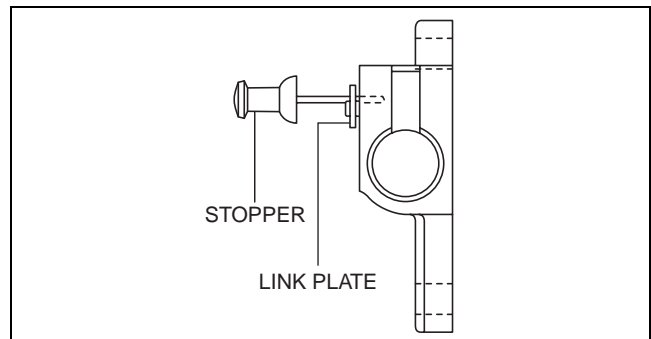

am3uuw0000861

MECHANICAL

9. Rotate the crankshaft clockwise two turns and inspect the valve timing.

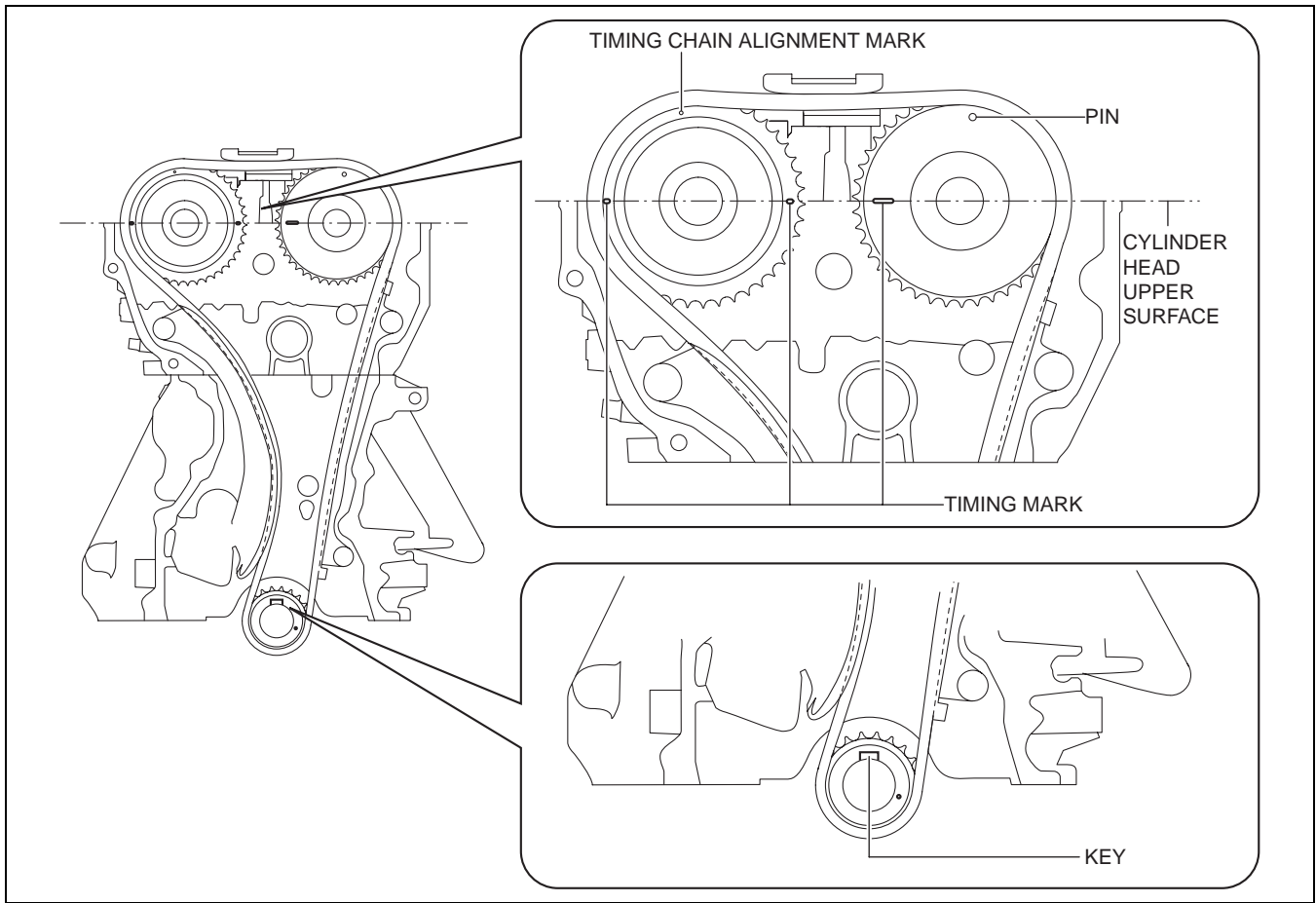

bpe2ue00000124

Engine Front Cover Assembly Note

Note

- For a new engine front cover, the positioning pins in the two locations shown in the figure project to the outside of the engine.

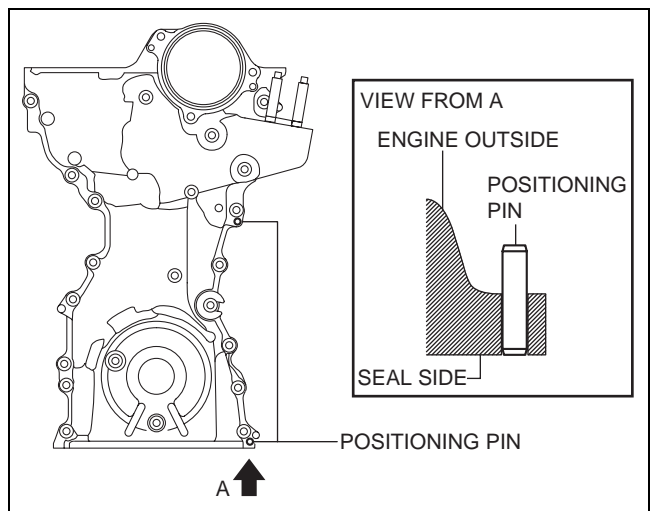

bpe2ue00000125

MECHANICAL

1. If the engine front cover is newly replaced, tap the positioning pins in the two locations to the seal surface side.
2. Completely clean and remove any oil, dirt, sealant or other foreign material that may be adhering to the engine front cover, cylinder head, and cylinder block.
3. When reusing the engine front cover installation bolts, clean any old sealant from the bolts.

Caution

- Apply the silicon sealant in a single, unbroken line.
- To prevent silicone sealant from hardening, adhere the engine front cover to the cylinder block within 10 min. after silicone sealant is applied. Tighten the installation bolts completely soon after adhering.
- Using bolts with the old seal adhering could cause cracks in the cylinder head and cylinder block.

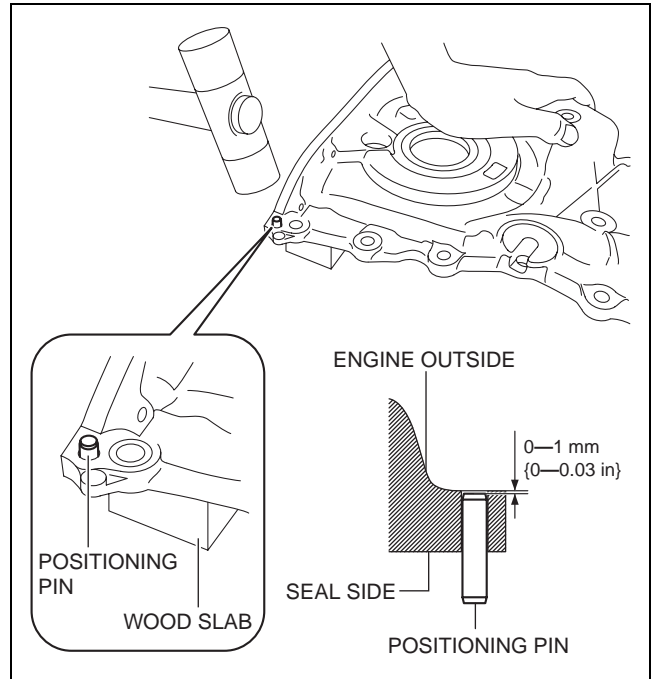

bpe2ue00000126

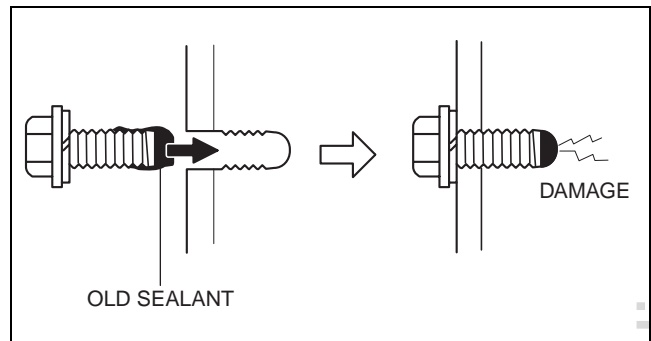

bpe2ue00000127

01-10

MECHANICAL

4. Apply silicone sealant to the engine front cover as shown in the figure.

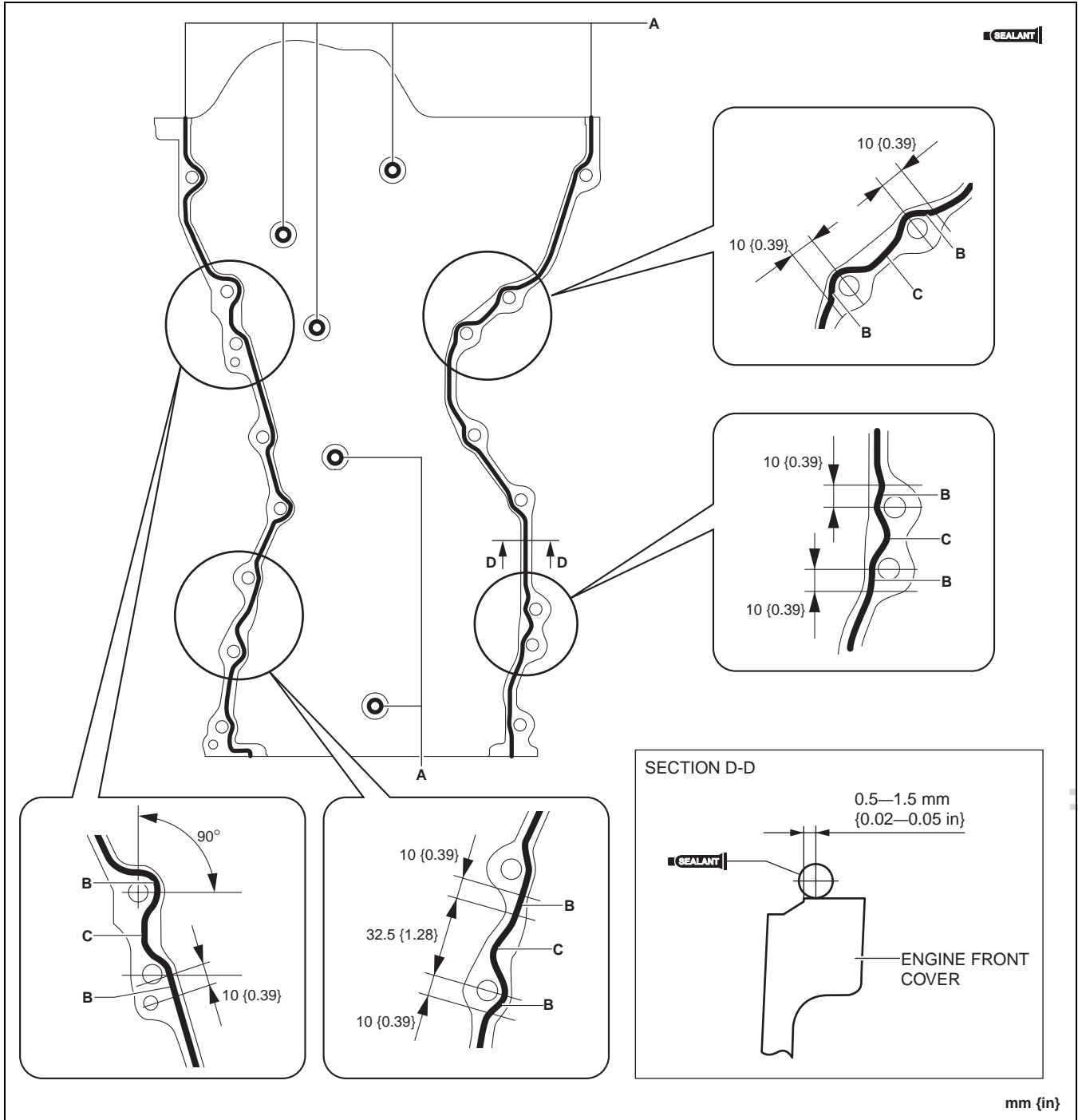

bpe2ue0000078

Bead thickness

- A: 2—6 mm {0.1—0.2 in}
- B: 4—6 mm {0.16—0.23 in}
- C: 4—8 mm {0.2—0.3 in}

MECHANICAL

5. Apply silicone sealant to the areas shown in the figure.

Caution

- Apply the silicone sealant so that it goes into the cylinder head gasket.

6. Install the engine front cover to the engine.

Note

- Temporarily install an appropriate bolt to the drive belt auto tensioner installation bolt hole to prevent:
 - A silicone sealant adhesion malfunction in the drive belt auto tensioner installation bolt hole.
 - A bolt mis-installation due to silicone sealant hardening.

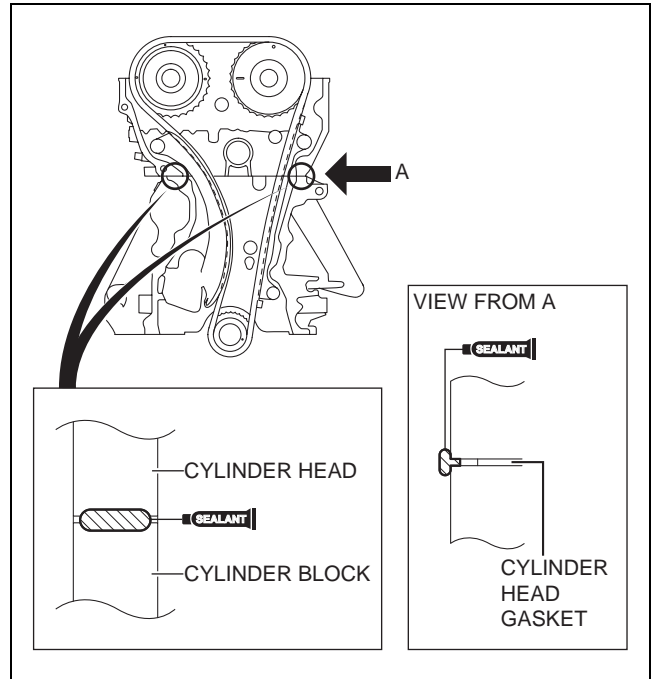

01-10

7. Prepare an appropriate **M8 X 1.25** bolt (length **40 mm {1.6 in}**).

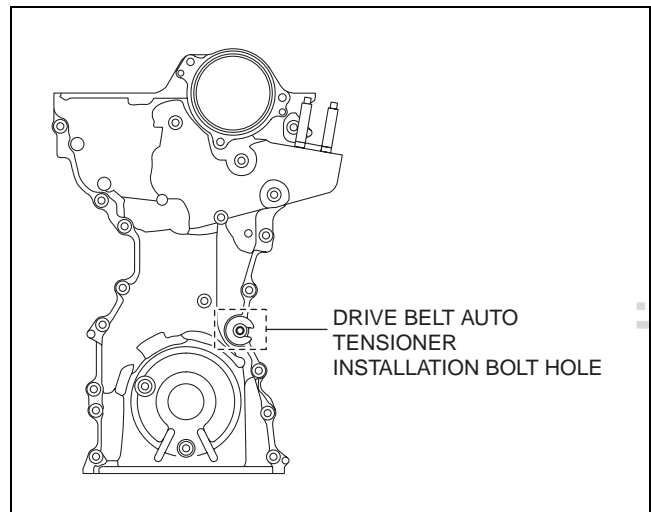

MECHANICAL

8. Tighten the engine front cover installation bolts in the order shown in the figure.

Tightening torque

20—26 N·m {2.1—2.6 kgf·cm, 15—19 in·lbf}

9. Remove the bolt installed to the drive belt auto tensioner installation bolt hole when installing the drive belt auto tensioner.

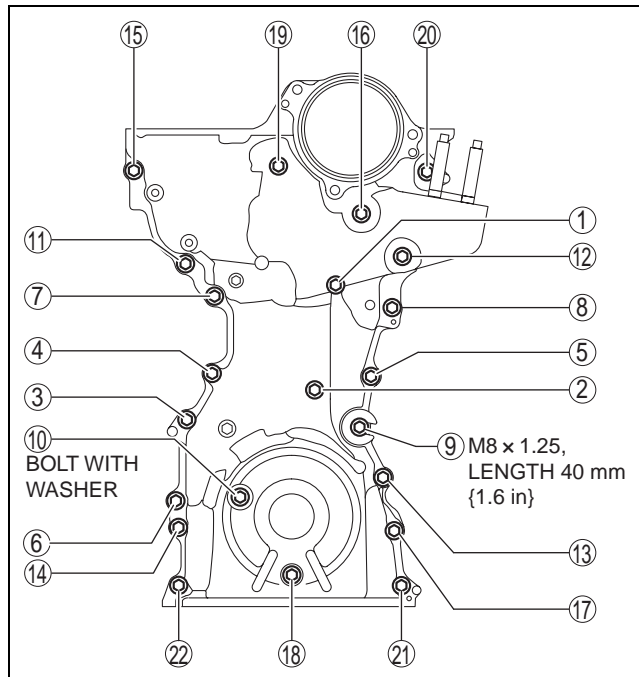

bpe2ue0000079

Oil Pan Assembly Note

1. Completely clean and remove any oil, dirt, sealant or other foreign material that may be adhering to the cylinder block and oil pan.
2. When reusing the oil pan installation bolts, clean any old sealant from the bolts.

Caution

- Apply the silicon sealant in a single, unbroken line around the whole perimeter.
- To prevent silicone sealant from hardening, adhere the oil pan to the cylinder block within 10 min. after silicone sealant is applied. Tighten the installation bolts completely soon after adhering.
- Using bolts with the old sealant adhering could cause cracks in the cylinder block, etc.

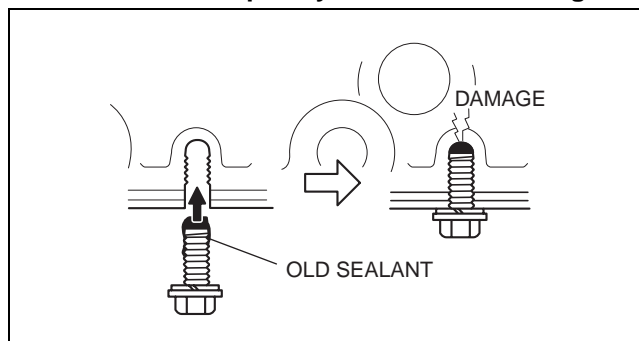

am6zzw00002304

MECHANICAL

3. Apply silicone sealant to the oil pan along the inside of the bolt holes as shown in the figure.

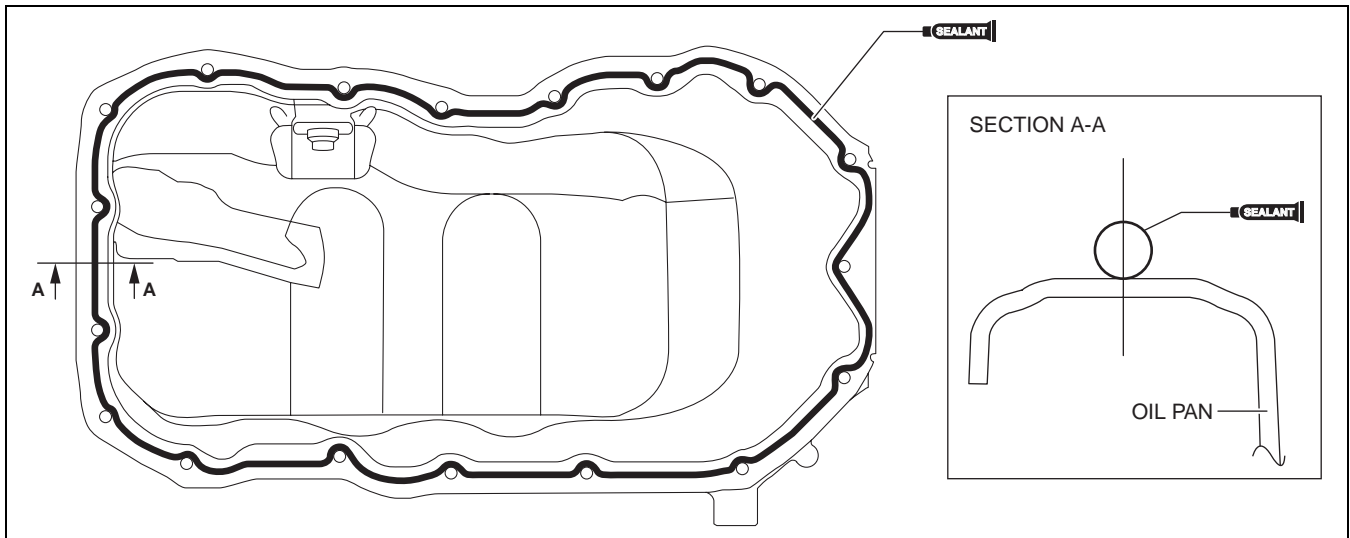

01-10

bpe2ue0000080

Thickness

2.0—6.0 mm {0.08—0.23 in}

4. Install the oil pan to the cylinder block.
5. Tighten the bolts in the order shown in the figure.

Tightening torque

8—11 N·m {82—112 kgf·cm, 71—97 in·lbf}

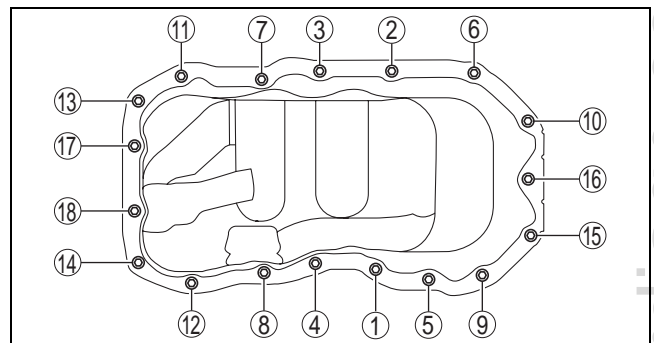

am3uuw00008918

Electric Variable Valve Timing Motor/Driver Assembly Note

1. Install a new O-ring to the O-ring installation groove of the engine front cover.

Caution

- To prevent damage to the electric variable valve timing motor/driver, do not apply excessive force (force of 100 N {10.2 kgf, 22.5 lbf} or more) to the shaded areas shown in the figure.

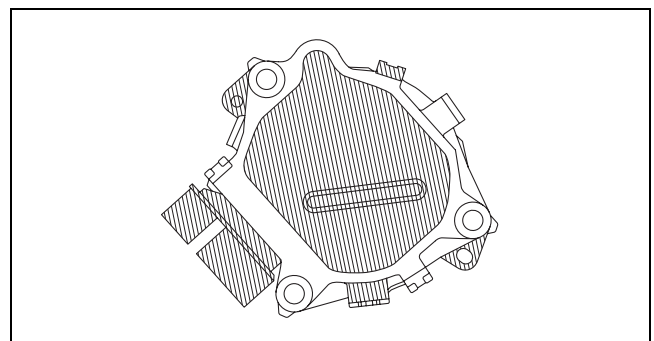

bpe2ue00000128

MECHANICAL

2. Install the electric variable valve timing motor/driver using the following procedures.

Note

- The eccentric shaft on the electric variable valve timing actuator side can be rotated to the left and right.
- The electric variable valve timing motor/driver can be assembled with the joint groove of the eccentric shaft in any position, and it will not lead to vehicle damage or performance reduction.

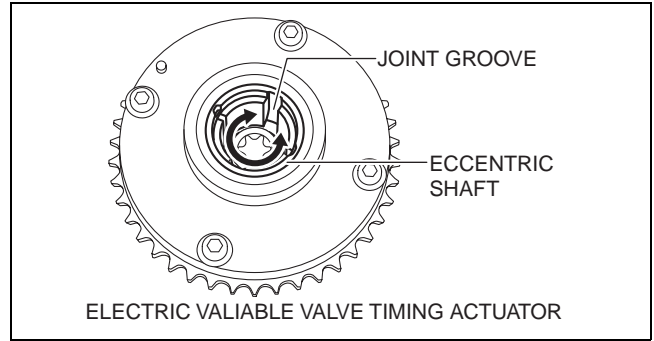

am3uuw00009042

- (1) Before installation, rotate the joint of the end of the electric variable valve timing motor so that it is aligned to the joint groove on the electric variable valve timing actuator side.
- (2) Engage the joint on the end of the electric variable valve timing motor with the joint groove on the electric variable valve timing actuator side.
- (3) Attach the seal surface.
- (4) Tighten the electric variable valve timing motor/driver installation bolts.

Tightening torque

20—26 N·m {2.1—2.6 kgf·m, 15—19 ft·lbf}

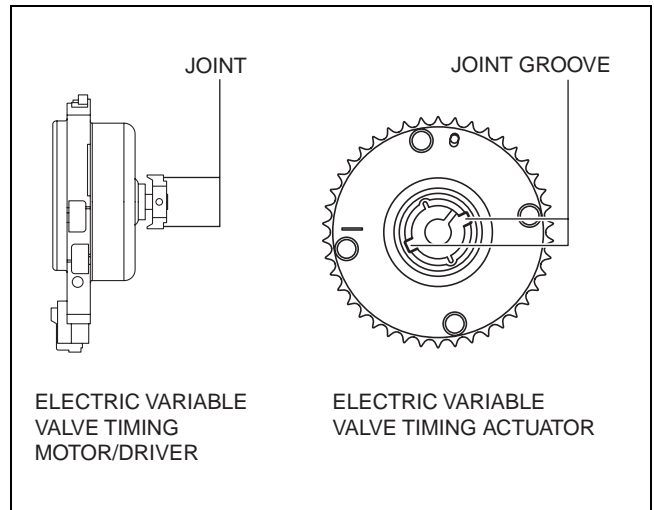

am3uuw00009043

Front Oil Seal Assembly Note

1. Apply clean engine oil to the inner surface of a new front oil seal.
2. Insert the front oil seal into the engine front cover by hand.
3. Tap the oil seal in evenly using the **SST** and a hammer.

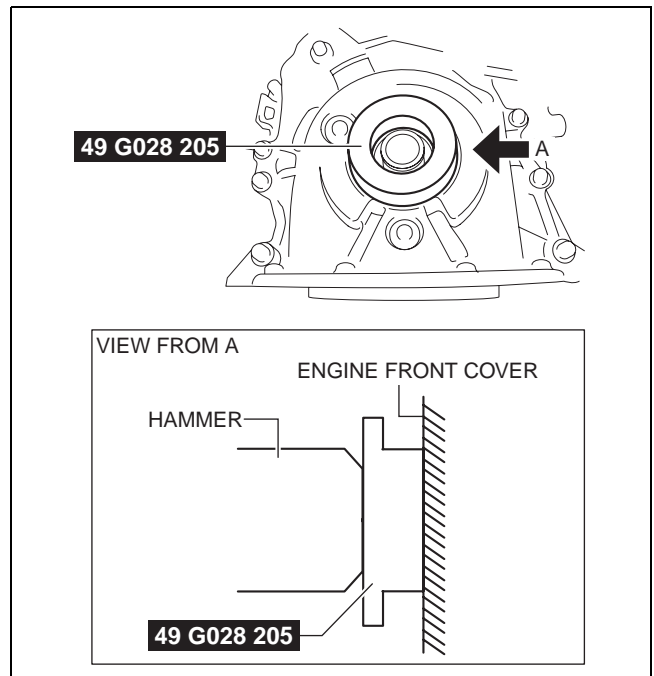

am3uuw00008830

Front oil seal press-in amount
 0—0.5 mm {0—0.019 in}

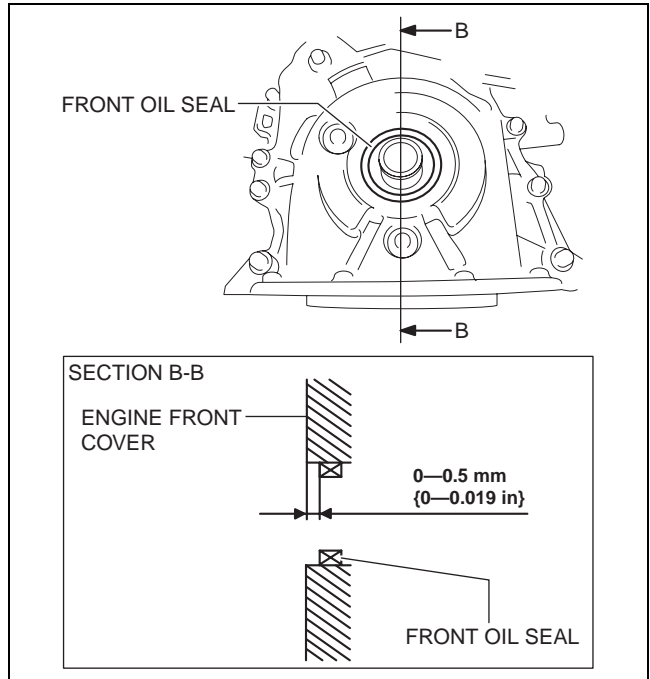

01-10

Crankshaft Pulley Lock Bolt Assembly Note

1. Hold the crankshaft using the **SST**.
2. Tighten the crankshaft pulley lock bolt in the order shown in the following two steps.

Tightening procedure

- Step 1:** 90—110 N·m {9.2—11 kgf·m, 67—81 ft·lbf}
- Step 2:** 55—65°

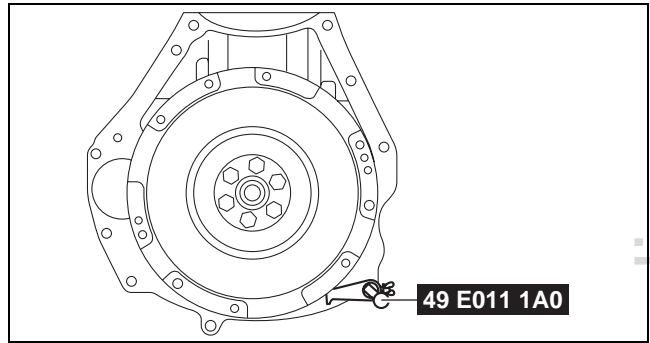

cardiagn.com

MECHANICAL

Water Pump Pulley Assembly Note

Caution

- Be careful not to damage the belt groove and surface of the water pump pulley when using tools, otherwise it will cause wear, breakage, abnormal noise of the drive belt (stretch belt), damage to the pulley, and rust.

1. Install the water pump pulley to the water pump and temporarily tighten the bolt.
2. Align the water pump pulley hole with the water pump hole as shown in the figure.

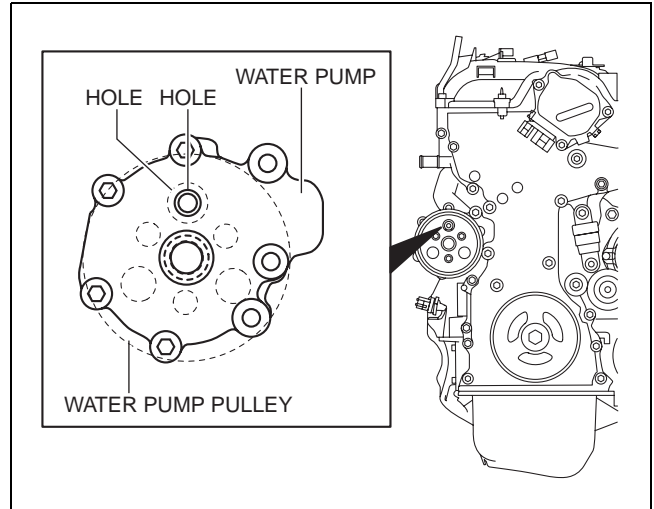

bpe2ue0000081

3. Insert an appropriate bolt (length **70 mm {2.8 in}**) into the water pump hole shown in the figure and lock the water pump pulley against rotation.
4. Completely tighten the water pump pulley bolt to the specified torque.

Tightening torque

8—11 N·m {82—112 kgf·cm, 71—97 in·lbf}

5. Remove the bolt used for locking the water pump pulley against rotation.

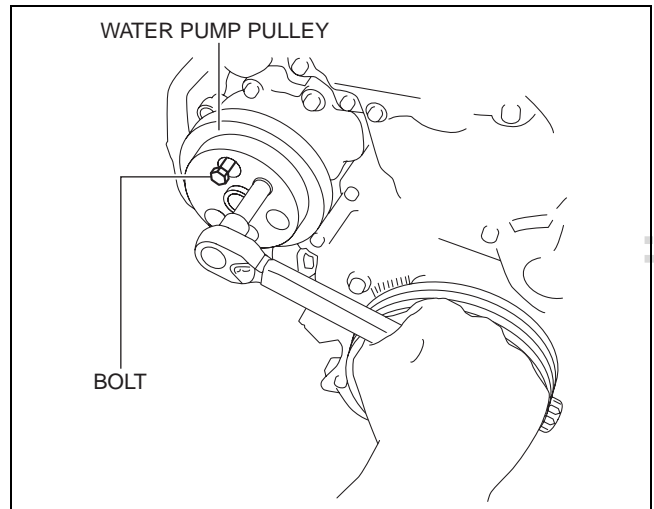

am3uuw0000874

Oil Shower Pipe Installation Note

Caution

- If the bolt is tightened with oil adhering to the bolt and the oil shower pipe connector seat shown in the figure, the axial force of the bolt will strengthen and could cause the connector seat to deform. Before installing, remove oil from the bolt and the oil shower pipe connector seat.

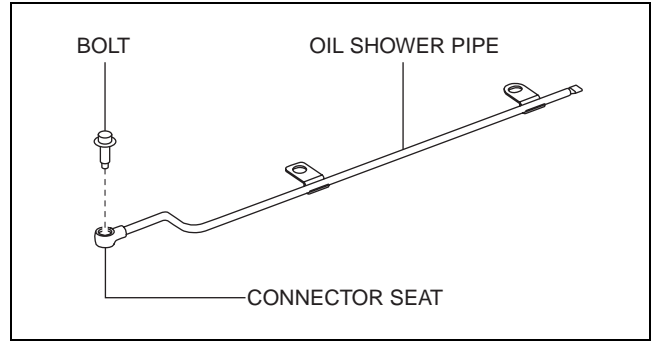

am3uuw00008876

01-10

1. Install the oil shower pipe in the order shown in the figure.

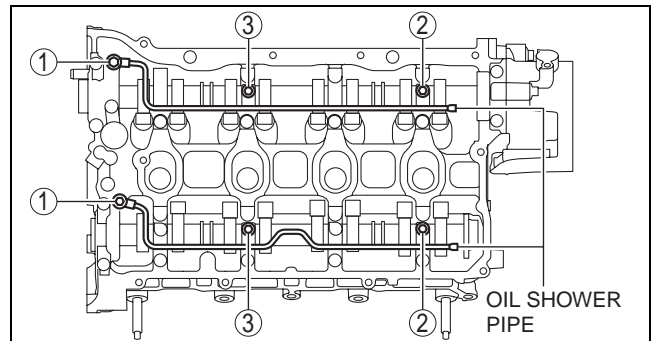

bpe2ue00000129

Tightening torque

Installation position	Tightening torque
1	9—12 N·m {92—122 kgf·cm, 80—106 in·lbf}
2, 3	8.0—9.0 N·m {82—91 kgf·cm, 71—79 in·lbf}

Cylinder Head Cover Installation Note

Caution

- To assure the sealing performance of the cylinder head cover, be careful of the following:
 - Verify that the cylinder head cover gasket is inserted into the cylinder head cover groove and install the cylinder head cover.
 - Completely clean and remove any oil, dirt, sealant or other foreign material from the seal surface.
- To prevent silicone sealant from hardening, adhere the cylinder head cover and the cylinder head within 10 min. after silicone sealant is applied. Tighten the installation bolts completely soon after adhering.

1. Insert a new cylinder head cover gasket into the cylinder head cover groove.

MECHANICAL

2. Apply silicone sealant to the areas shown in the figure.

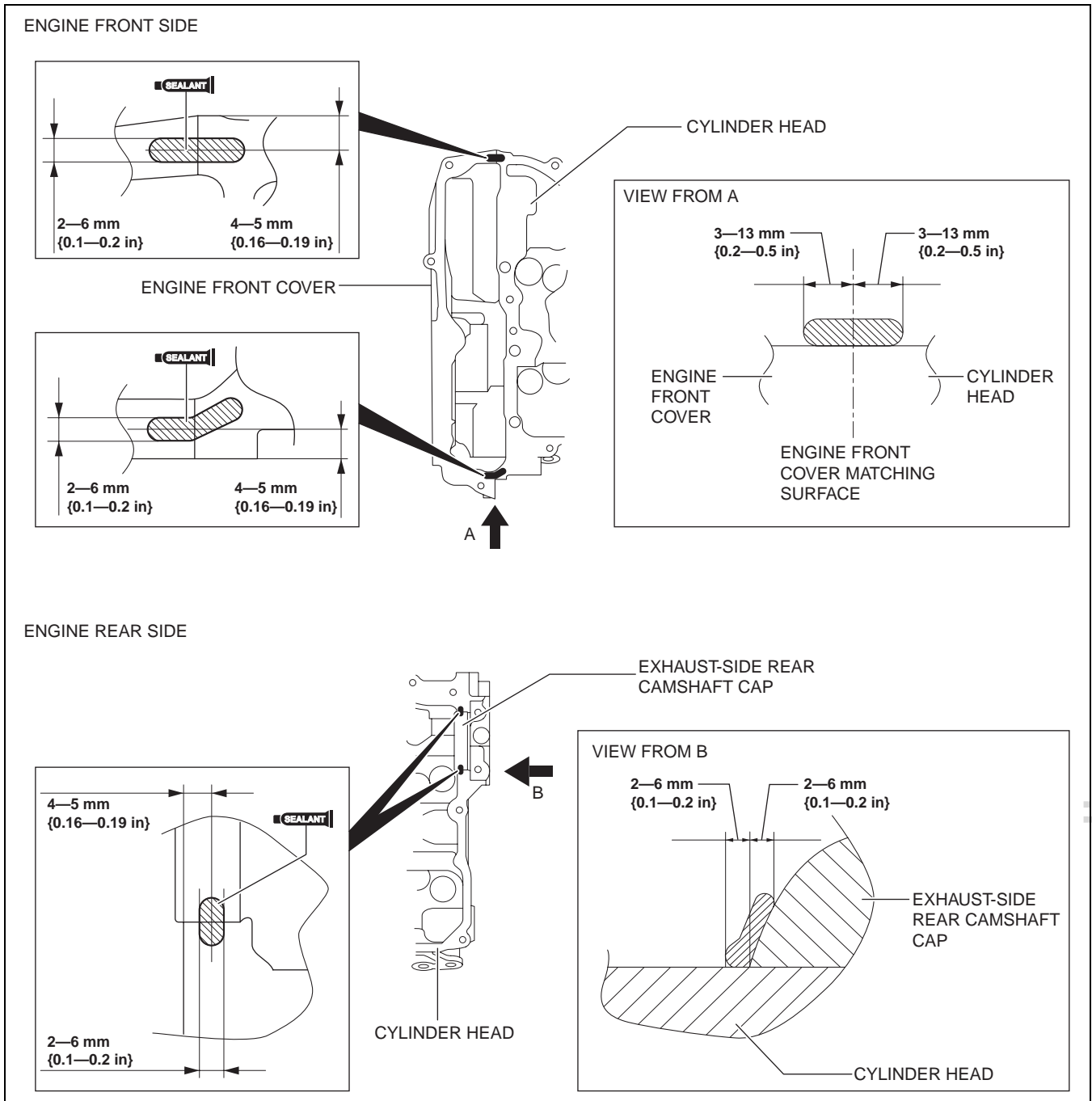

bpe2ue0000082

3. Tighten the cylinder head cover bolts in the order shown in the figure.

Tightening torque

4.5—7.0 N·m {46—71 kgf·cm, 40—61 in·lbf}

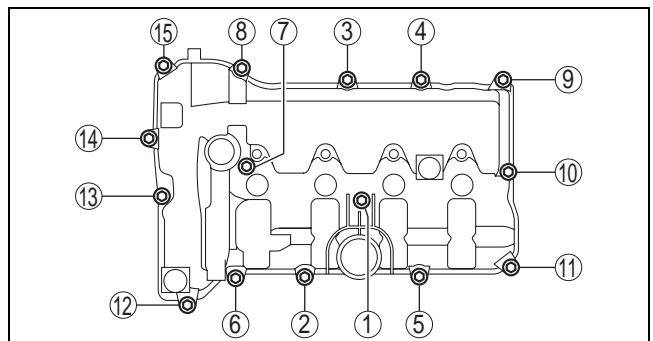

am3uuw0000879

TECHNICAL DATA

01-50 TECHNICAL DATA

ENGINE TECHNICAL DATA 01-50-1

ENGINE TECHNICAL DATA

id015000800100

01-50

Item	Specification
OCV coil resistance	6.9—7.5 ohms [20°C {68°F}]
Maximum distortion, head gasket side of the cylinder head	0.05 mm {0.002 in}
Maximum distortion, manifold side	IN: 0.10 mm {0.0039 in} EX: 0.05 mm {0.002 in}
Maximum cutting length, manifold side	IN: Cutting not authorized EX: 0.20 mm {0.0079 in}
Standard valve seat contact width	1.41 mm {0.0555 in}
Valve seat angle	45°
Standard valve seat sinkage amount (Dimension L)	IN: 48.73—50.27 mm {1.919—1.979 in} EX: 48.73—50.27 mm {1.919—1.979 in}
Standard valve head margin thickness	IN: 1.75—1.95 mm {0.0689—0.0767 in} EX: 1.95—2.15 mm {0.0768—0.0846 in}
Standard valve length	IN: 106.55—107.15 mm {4.1949—4.2185 in} EX: 116.55—117.15 mm {4.5886—4.6122 in}
Minimum valve length	IN: 106.33 mm {4.1862 in} EX: 116.33 mm {4.5799 in}
Standard valve stem diameter	IN: 5.470—5.485 mm {0.2154—0.2159 in} EX: 5.465—5.480 mm {0.2152—0.2157 in}
Minimum valve stem diameter	IN: 5.424 mm {0.2135 in} EX: 5.419 mm {0.2133 in}
Standard valve guide inner diameter	IN: 5.510—5.530 mm {0.2170—0.2177 in} EX: 5.510—5.530 mm {0.2170—0.2177 in}
Standard clearance between valve stem and guide	IN: 0.025—0.060 mm {0.0010—0.0023 in} EX: 0.030—0.065 mm {0.0012—0.0025 in}
Maximum clearance between valve stem and guide	0.10 mm {0.0039 in}
Standard valve guide projection height	IN: 16.4—17.0 mm {0.646—0.669 in} EX: 16.4—17.0 mm {0.646—0.669 in}
Valve spring installation height	IN: When pressurized with spring force of 190—210 N {19.4—21.4 kgf, 42.8—47.2 lbf}, spring height is 38.0 mm {1.50 in} EX: When pressurized with spring force of 228—252 N {23.3—25.6 kgf, 51.3—56.6 lbf}, spring height is 38.0 mm {1.50 in}
Maximum valve spring off-square	IN: 2.0° (1.6 mm {0.063 in}) EX: 2.0° (1.7 mm {0.067 in})
Maximum camshaft runout	0.030 mm {0.0012 in}
Standard cam height	IN: 41.57 mm {1.637 in} EX: 40.37 mm {1.589 in}
Minimum cam height	IN: 41.50 mm {1.634 in} EX: 40.30 mm {1.587 in}
Standard camshaft journal diameter	24.96—24.98 mm {0.9827—0.9834 in}
Minimum camshaft journal diameter	24.93 mm {0.9815 in}
Standard camshaft journal oil clearance	0.035—0.080 mm {0.0014—0.0031 in}
Maximum camshaft journal oil clearance	0.090 mm {0.0035 in}
Standard camshaft end play	0.07—0.22 mm {0.003—0.008 in}
Maximum camshaft end play	0.23 mm {0.0091 in}
Maximum distortion, head gasket side of the cylinder block	0.10 mm {0.0039 in}
Standard cylinder bore diameter	83.50—83.53 mm {3.2875—3.2885 in}
Air pressure	180—220 kPa {1.84—2.24 kgf/cm ² , 26.2—31.9 psi}
Standard piston outer diameter	83.465—83.495 mm {3.2861—3.2872 in}
Standard clearance between piston and cylinder	0.025—0.045 mm {0.0010—0.0017 in}

01-50-1

TECHNICAL DATA

Item	Specification
Maximum clearance between piston and cylinder	0.063 mm {0.0025 in}
Standard clearance between piston ring and ring groove	Top: 0.04—0.08 mm {0.002—0.003 in} Second: 0.03—0.07 mm {0.0012—0.0027 in} Oil: 0.04—0.12 mm {0.002—0.004 in}
Maximum clearance between piston ring and ring groove	Top: 0.12 mm {0.0047 in} Second: 0.10 mm {0.0039 in} Oil: 0.17 mm {0.0067 in}
Standard piston ring end gap	Top: 0.13—0.18 mm {0.0052—0.0070 in} Second: 0.18—0.28 mm {0.008—0.011 in} Oil: 0.10—0.35 mm {0.004—0.013 in}
Maximum piston ring end gap	Top: 0.35 mm {0.014 in} Second: 0.45 mm {0.018 in} Oil: 0.52 mm {0.020 in}
Standard piston pin outer diameter	20.995—21.000 mm {0.82658—0.82677 in}
Standard piston pin hole diameter	21.004—21.008 mm {0.82693—0.82708 in}
Standard clearance between piston pin hole diameter and piston pin outer diameter	0.004—0.013 mm {0.0002—0.0005 in}
Standard connecting rod small end inner diameter	21.006—21.017 mm {0.82701—0.82744 in}
Standard clearance between connecting rod small end inner diameter and piston pin outer diameter	0.006—0.022 mm {0.0003—0.0008 in}
Maximum connecting rod bending	0.050 mm {0.0020 in}
Maximum connecting rod distortion	0.050 mm {0.0020 in}
Connecting rod center-to-center distance	155.2 mm {6.110 in}
Standard side clearance at the large end of connecting rod	0.14—0.36 mm {0.006—0.014 in}
Maximum side clearance at the large end of connecting rod	0.465 mm {0.0183 in}
Standard bearing oil clearance at the large end of the connecting rod	0.026—0.052 mm {0.0011—0.0020 in}
Maximum bearing oil clearance at the large end of the connecting rod	0.10 mm {0.0039 in}
Connecting rod bearing size	STD: 1.503—1.520 mm {0.05918—0.05984 in} OS 0.25: 1.628—1.631 mm {0.06410—0.06421 in} OS 0.50: 1.753—1.756 mm {0.06902—0.06913 in}
Standard crankshaft end play	0.08—0.29 mm {0.004—0.011 in}
Maximum crankshaft end play	0.30 mm {0.012 in}
Thrust bearing size	STD: 2.500—2.550 mm {0.0985—0.1003 in} OS0.25: 2.625—2.675 mm {0.1034—0.1053 in}
Maximum main journal runout	0.10 mm {0.0039 in}
Standard main journal diameter	46.980—47.000 mm {1.8497—1.8503 in}
Maximum main journal off-round	0.005 mm {0.0002 in}
Standard crank pin diameter	46.980—47.000 mm {1.8497—1.8503 in}
Maximum crank pin off-round	0.005 mm {0.0002 in}
Standard main journal oil clearance	0.016—0.039 mm {0.0007—0.0015 in}
Maximum main journal oil clearance	0.084 mm {0.0033 in}
Main bearing size	STD: 2.489—2.510 mm {0.0980—0.0988 in} OS 0.25: 2.614—2.617 mm {0.10292—0.10303 in} OS 0.50: 2.739—2.742 mm {0.10784—0.10795 in}
Flywheel maximum runout	0.10 mm {0.0039 in}
Standard cylinder head bolt length	145.2—145.8 mm {5.717—5.740 in}
Maximum cylinder head bolt length	146.5 mm {5.768 in}
Standard connecting rod bolt length	43.7—44.3 mm {1.73—1.74 in}
Maximum connecting rod bolt length	45.0 mm {1.77 in}
Rear oil seal press-in amount	0—0.5 mm {0—0.019 in}
Front oil seal press-in amount	0—0.5 mm {0—0.019 in}

01-50-2

01-60 SERVICE TOOLS

ENGINE SST 01-60-1

ENGINE SST

id016000119200

01-60



1: Mazda SST number
2: Global SST number

Example

1:49 E011 1A0
2: -

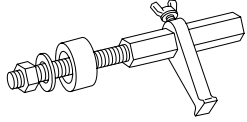
Ring gear brake set

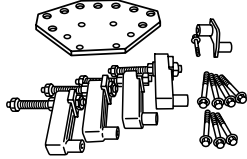
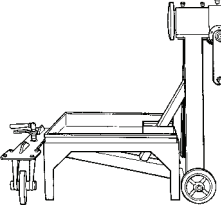
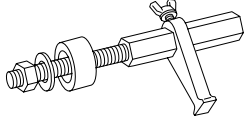
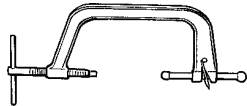
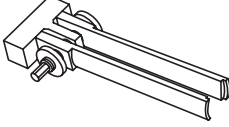
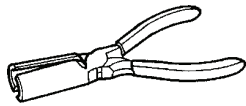
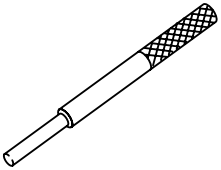
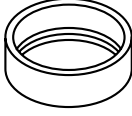

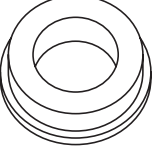
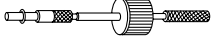
<p>1:49 L010 1A0 2: -</p> <p>Engine hanger set</p> 	<p>1:49 0107 680A 2: -</p> <p>Engine stand</p> 	<p>1:49 E011 1A0 2: -</p> <p>Ring gear brake set</p> 
<p>1:49 0636 100B 2: -</p> <p>Valve spring lifter arm</p> 	<p>1:49 B012 0A2A 2: -</p> <p>Pivot</p> 	<p>1:49 S120 170 2: -</p> <p>Valve seal remover</p> 
<p>1:49 B012 015 2: -</p> <p>Valve guide installer</p> 	<p>1:49 E033 101 2: -</p> <p>Dust cover installer</p> 	<p>1:49 B012 016 2: -</p> <p>Attachment</p> 
<p>1:49 G028 205 2: -</p> <p>Oil seal installer</p> 	<p>1:49 1285 071 2: -</p> <p>Bearing puller</p> 	<p>-</p>

cardiagn.com

