

RS Cosworth

Foreword

The Sierra RS Cosworth is the latest product of Ford's long and fruitful collaboration with Cosworth, developers of some of the worlds most famous competition engines.

In addition to the 16 valve engine the Sierra RS Cosworth includes a considerable number of new components and systems, all designed to make it the most exciting and exhilarating saloon car ever sold by Ford.

This Technician Information has been developed to inform you, the Service Technician, about these new components and systems and their maintenance requirements.

More detailed information is included in the Special Workshop Manual on the Cosworth RS Sierra.

Service Training Programmes

October 1985

D-P/GK-T-1

Contents

Page

General 4

PART A – Engine, Engine Management and Turbocharger

1. The Ford Cosworth Engine 6

1.1 Engine Components 8

 The Cylinder Head 9

 Front Belt Drive 14

 Crank Case Assembly 16

 Oilpump and Lubrication Circuit 19

 Engine Crankcase Ventilation 21

1.2 Repair Information 22

 Important Notes on Cylinderhead – Removal and Installation 23

 Important Notes on Cylinderhead – Disassembly and Assembly 26

 Further important Repair Notes 29

2. The Electronic Engine Management 32

2.1 General Description 32

2.2 System Components – Fuel System 34

 – Air System 36

 – Ignition System 37

2.3 System Sensors and Actuators 38

3. The Turbocharger 44

3.1 General Description 44

3.2 Boost Pressure Control 46

PART A – Engine, Engine Management and Turbocharger (cont'd).

4. Maintenance, Service Adjustments and System Checks	48
4.1 Maintenance	48
4.2 Service Adjustments	48
4.3 System Checks	50
5. Technical Data – Part A	53

PART B – Transmission and Rear Axle

1. Transmission	54
1.1 General Description	
1.2 Power Flow	56
1.3 Important Notes on Disassembly and Assembly	58
2. Rear Axle and Suspension	62
3. Technical Data – Part B	64

PART C – Front Axle and Suspension 66

PART D – Anti-Lock Braking System (ABS) 68

1. General Description	68
2. The Sierra RS Cosworth Anti-Lock Braking System	70
3. Technical Data	73

PART E – Body Features, Wheels and Tyres

1. Exterior dress up, Wheels and Tyres	74
2. Interior Features	76

General

The Sierra RS Cosworth is available as a 3 door Saloon car and is instantly recognisable from the way it sits low on the road and from its unique body panels. Front and rear wheel arch extensions cover the extra wide tyres mounted on 15" x 7" racing style light alloy road wheels. A new front grill panel with a single large cooling slot; a unique bumper with air dam; brake cooling pick-up point and louvres in the hood for optimum air flow are the main features of the front end.

A single plane arefoil/rear wing generates the positive down force required for traction and handling.

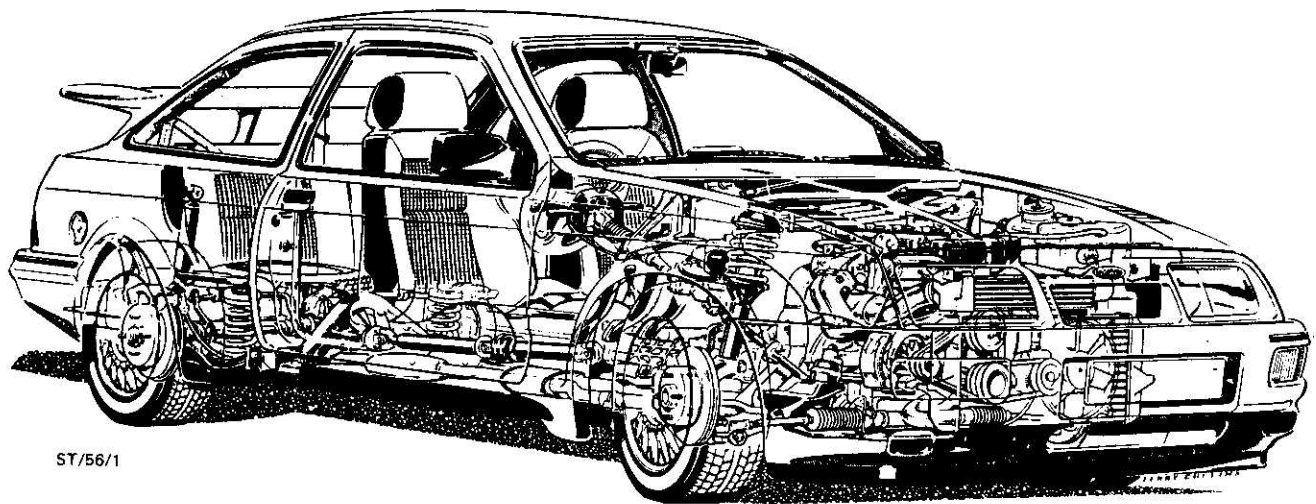

(RHD-Version shown)

General (cont'd.)

The 16 valve Cosworth engine presents the key element of the Sierra RS Cosworth. It uses the engine block from the proven Ford OHC engine but is completed with a host of new components and systems such as

- The new cylinder head with its two camshafts to actuate the 4 valves of each cylinder
- A water cooled Garret turbo charger
- A Weber electronic fuel injection system and
- an ignition system made by Marelli.

However, in addition to its unique power plant, Sierra RS Cosworth houses a host of other new or modified components and systems a Service Technician needs to be familiar with and these are

- A close ratio 5 speed transmission
- New clutch and driveshaft
- Limited slip differential similar to Scorpio
- Revised rear axle mounting
- Revised front and rear suspension with power steering and specially tuned shock absorbers and springs to meet Sierra RS Cosworths demands on road holding and road adhesion
- Teves ABS braking system similar to the system used on Scorpio.

In addition to this exciting list of features the interior has been redesigned to match the vehicles sporty appearance and to provide the driver with the environment required for a car of this class.

PART A – Engine, Engine Management and Turbocharger

1. The Ford Cosworth Engine

General Information

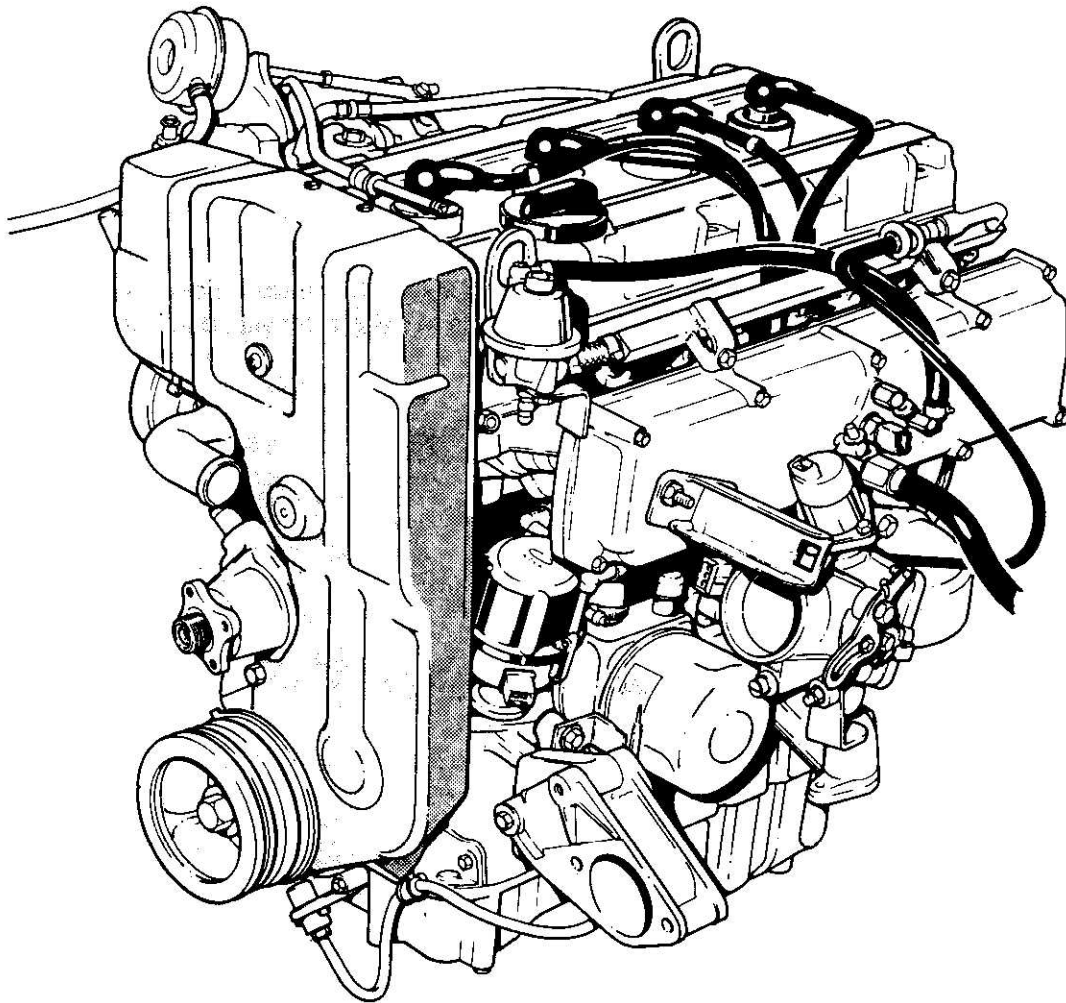

ST/56/3

ACM

The Ford Cosworth 2.0 litre 16 valve D OHC Engine with Turbocharger

PART A – Engine, Engine Management and Turbocharger

1. The Ford Cosworth Engine

General Information (cont'd.)

- Sierra's high performance 16 valve engine has been developed by Cosworth in England, a company well known for its racing car engines.

The Ford 2.0 ltr. OHC regular production cylinder block forms the mainstay of this engine.

- The valve cover bears the following identifications:

D OHC = Double Overhead Camshaft –
indicating that the engine has
two overhead camshafts

16 V = 16 valves

Turbo = Turbocharger

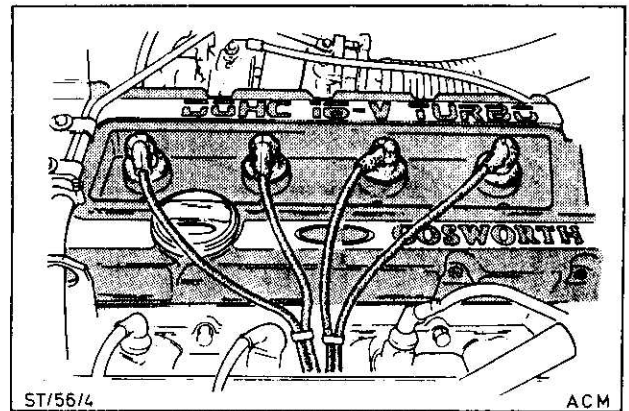

- Power = 150 kW (204 PS)
at 6000 rpm
- Max. Torque = 278 Nm at 4500 rpm
- Max. Engine speed
– continued running : 6500 rpm
– intermittent running: 6800 rpm

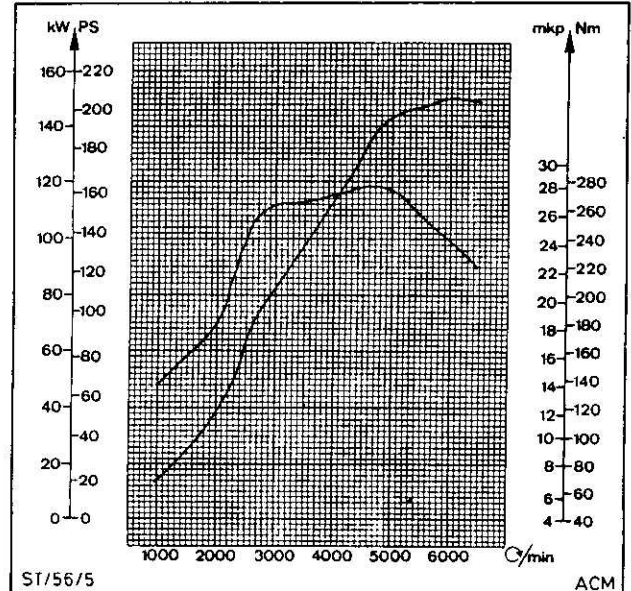

- Apart from the cylinder block, which has been selected from regular production, all other major components of the engine have been newly developed by either Ford or Cosworth or have been updated to suit the engine's high performance. Main feature of the engine is the 16 valve aluminium cylinder head with its two camshafts specially developed for this engine by Cosworth.

PART A – Engine, Engine Management and Turbocharger

1.1 Engine Components

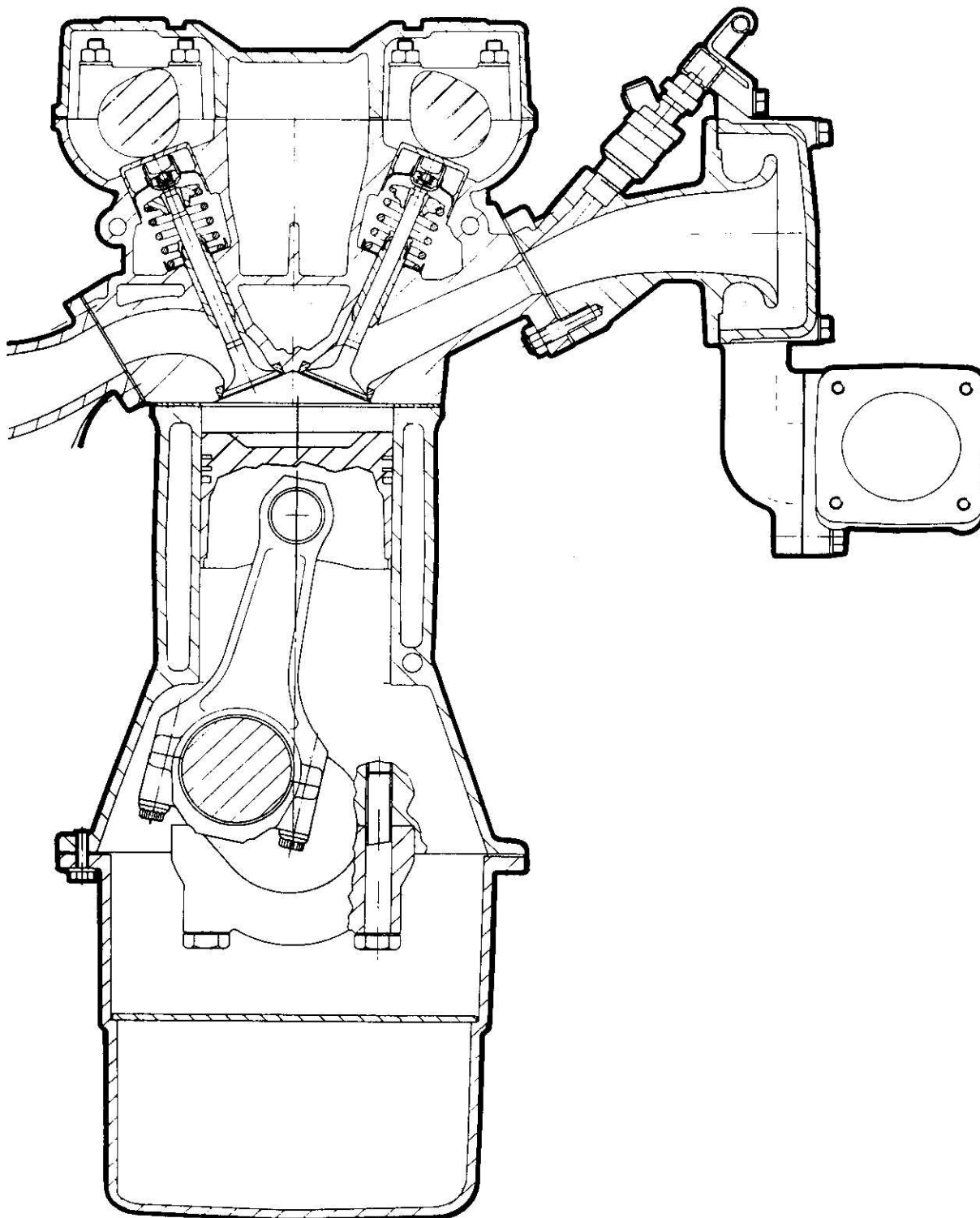

ST/56/11

ACM

Engine – front cross section

PART A – Engine, Engine Management and Turbocharger

1.1 Engine Components (cont'd.)

The Cylinder Head

- The Cosworth light-alloy cylinder head has two overhead camshafts – one for the inlet side and one for the exhaust side.
- A better volumetric efficiency is achieved by two inlet and two exhaust valves for each cylinder.
- The valves are inclined and their “V” arrangement has an angle of 22,5°.

Valve stem diameter – inlet valve 7.0 mm
– exhaust valve 8.0 mm

The exhaust valve stems are sodium filled for optimum cooling.

The exhaust valve stem is stepped and its upper end is 7.0 mm to enable identical valve retainers and collets to be used.

- The valves are actuated directly via hydraulic valve tappets. This eliminates the need for valve gap adjustment in service.
- Valve seats and guides are fitted in production by shrinking. Replacement can be done by specialists for this type of work.

Valve guides – inlet : Copper-alloy inner dia. 7.0 mm
exhaust : Copper-alloy inner dia. 8.0 mm

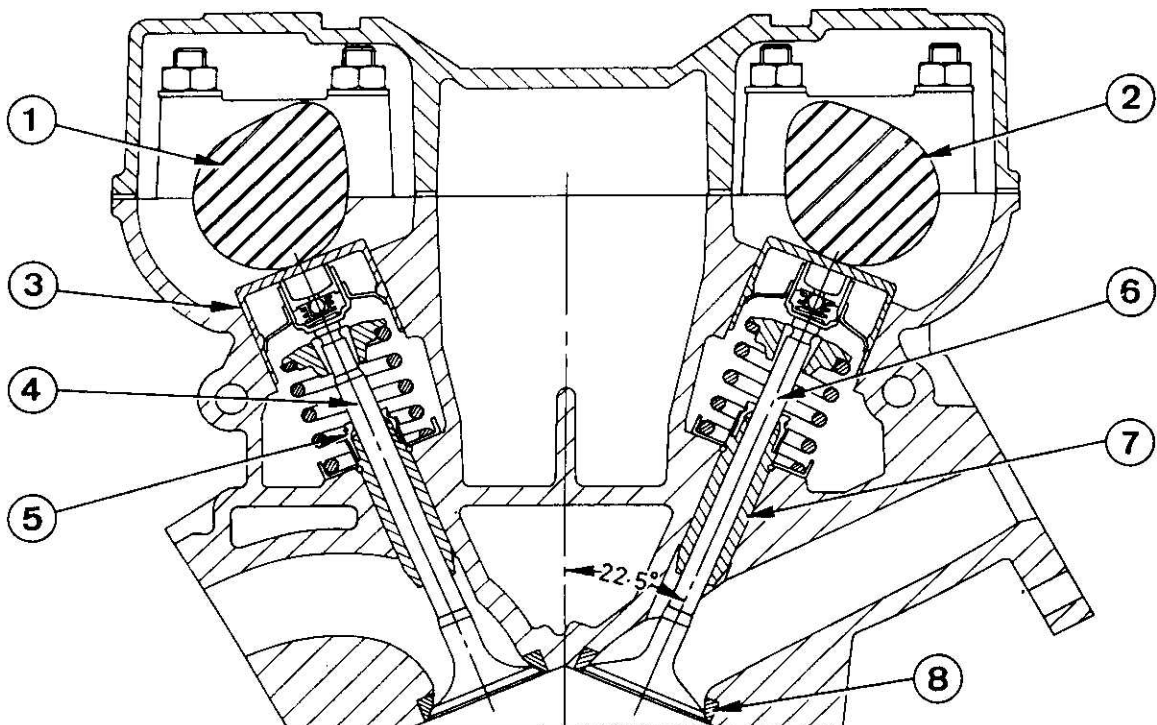

ST/56/12

ACM

- 1 = Camshaft – outlet side
- 2 = Camshaft – inlet side
- 3 = Hydraulic valve tappets
- 4 = Exhaust valves – sodium filled

- 5 = Valve stem seals
- 6 = Inlet valves
- 7 = Valve guides
- 8 = Valve seats

PART A – Engine, Engine Management and Turbocharger

1.1 Engine Components (Cylinder Head, cont'd.)

- The valve stem seals have a press fit on the valve guides. Removal is done with special pliers, for installation a special installer tool is required (refer section "Cylinder head – remove and install").

- Each camshaft is supported in five bearings with bolt-on bearing caps.
- The cam bearings are machined in such a manner, that bearing liners are not required.
- The bearing caps are marked 1 to 5 on the exhaust side and 6 to 10 on the inlet side with the counting starting from the front on both sides.

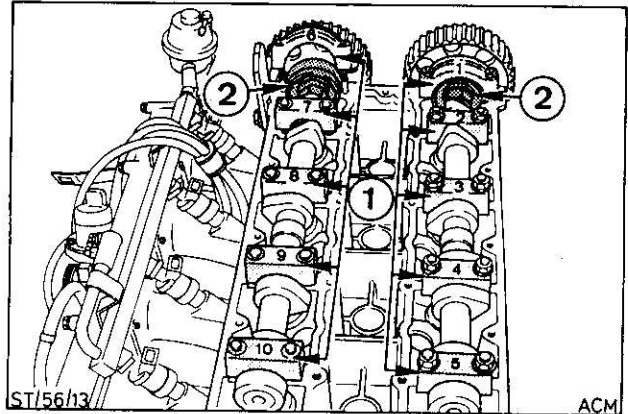

Camshaft support bearing

- 1 = Bearing cap
- 2 = Bearing retainer with bearing

- The front end of each camshaft is supported in a ball bearing to reduce the high start up torque transmitted through the timing belt of the sprocket wheel.

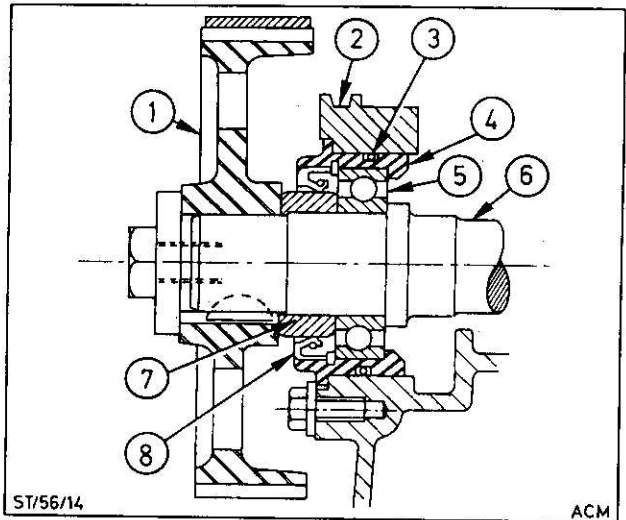

Camshaft front bearing

- 1 = Camshaft sprocket wheel
- 2 = Bearing cap
- 3 = O-Ring
- 4 = Bearing retainer
- 5 = Ball bearing
- 6 = Camshaft
- 7 = Oil seal race
- 8 = Oil seal

PART A – Engine, Engine Management and Turbocharger

1.1 Engine Components (Cylinder Head, cont'd.)

- The oil feed bores are located on the side of the support bearings.

The camshaft for the inlet valves has bearing journals with oil grooves to ensure complete lubrication of the bearing surface.

The camshaft for the exhaust valves does not need this oil groove because of the position of the oil feed bore.

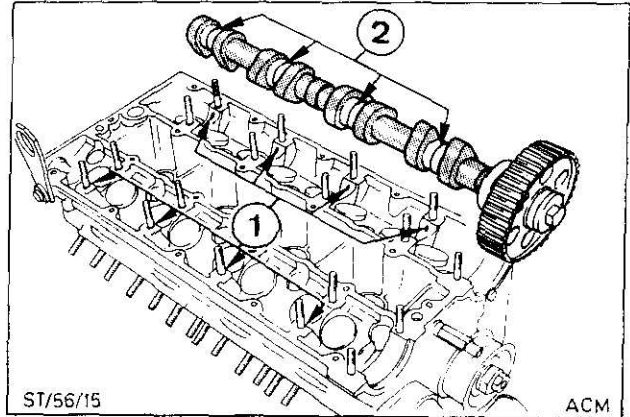

Lubrication of the camshaft

- 1 = Oil supply bore
- 2 = Lubrication groove

- The hydraulic valve tappets (bucket type) are supplied as an assembly. They should not be disassembled and must always be fitted into their original location.

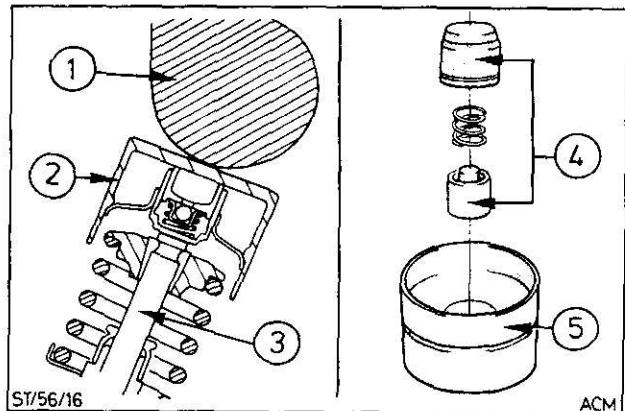

Hydraulic valve tappets

- 1 = Camshaft
- 2 = Hydraulic valve tappets
- 3 = Valve stem
- 4 = Piston, cylinder and spring of the hydraulic valve tappet
- 5 = Tappet housing with oil chamber

PART A – Engine, Engine Management and Turbocharger

1.1 Engine Components (Cylinder Head, cont'd.)

- The oil gallery of the cylinder head is fitted with a non-return valve which eliminates oil drain back after the engine is switched off

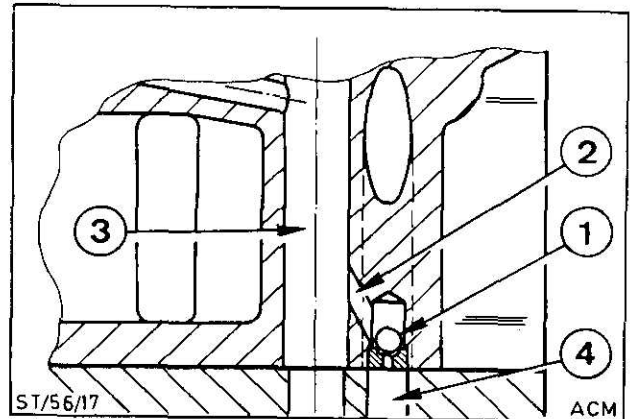

Anti-drain back valve in cylinder head

- 1 = Ball in closed position
(engine switched off)
- 2 = Cross drilling
- 3 = Cylinder head bolt drilling (oil gallery)
- 4 = Main oil gallery

When starting the engine the anti-drain back valve opens for immediate lubrication of the camshaft journals and hydraulic tappets.

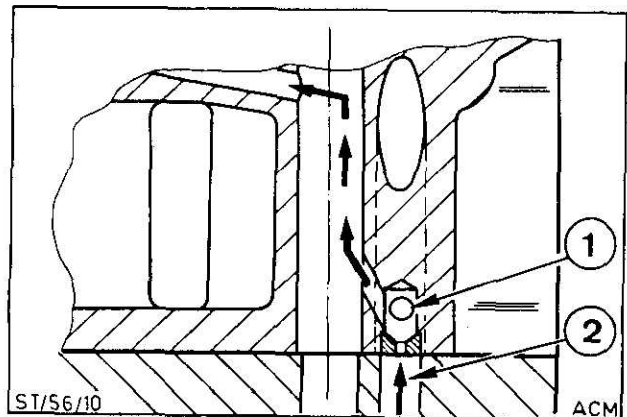

Anti-drain back valve in cylinder head

- 1 = Ball in open position
(with engine in operation)
- 2 = Direction of oil flow

- The cylinder head gasket differs from the standard OHC gasket in that it has revised openings to match the Cosworth cylinder head.

PART A – Engine, Engine Management and Turbocharger

1.1 Engine Components

Components fitted to the Cylinder Head

Inlet side:

- Inlet manifold (1)
- Air chamber (2) with bolted on fuel rail (3), pressure regulator (4) and push fit fuel injectors (5).
- Throttle housing (6) and elbow (7).

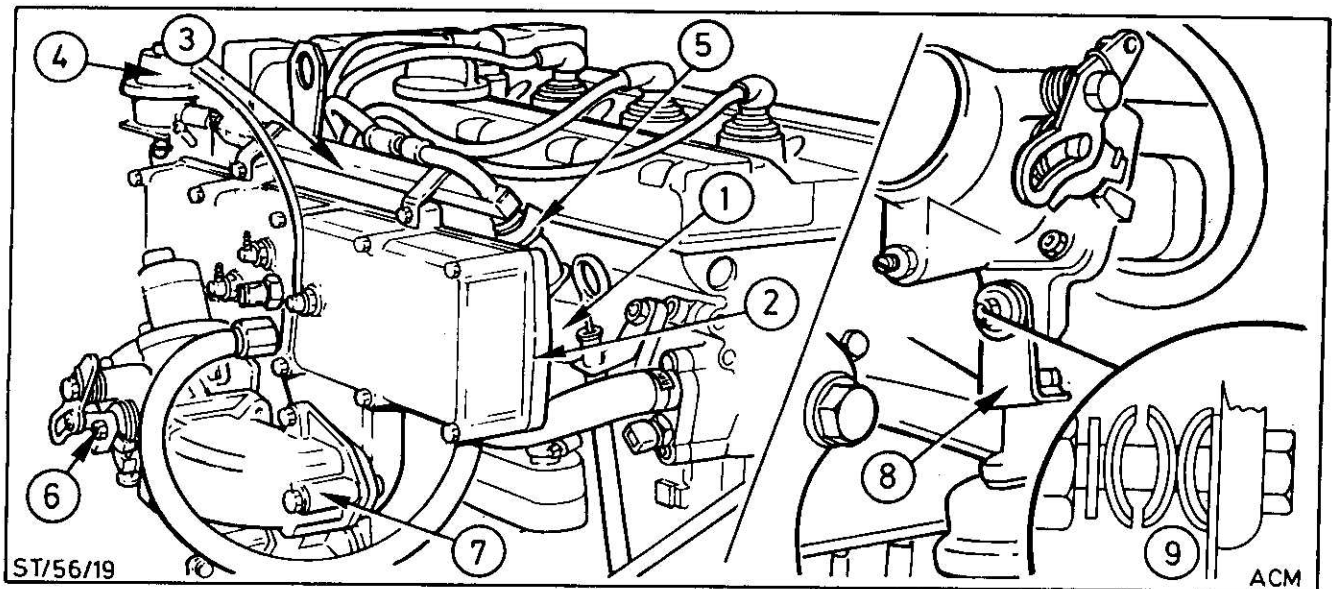

- The elbow is supported by a bracket (8) from the engine mounting. The elbow is fastened to the bracket by three pairs of special dished washers (9). This flexible mounting eliminates vibrations from the engine, which could affect the throttle position sensor. When disassembling, the position of the dished washers should be noted to ensure correct reassembling.

Outlet side:

- Two piece exhaust manifold (1) consisting of the primary manifold and the secondary manifold. Because of the high exhaust temperature, the manifold material consists of a heat-resistant cast iron (Ni-resist).
- The turbocharger is water-cooled and bolted to the exhaust manifold.

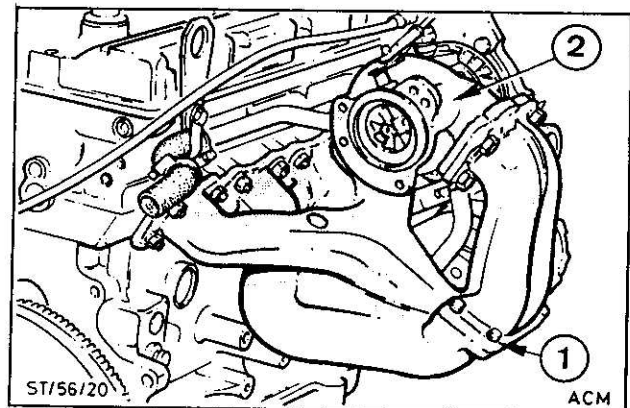

PART A – Engine, Engine Management and Turbocharger

1.1 Engine Components

Front Belt Drive

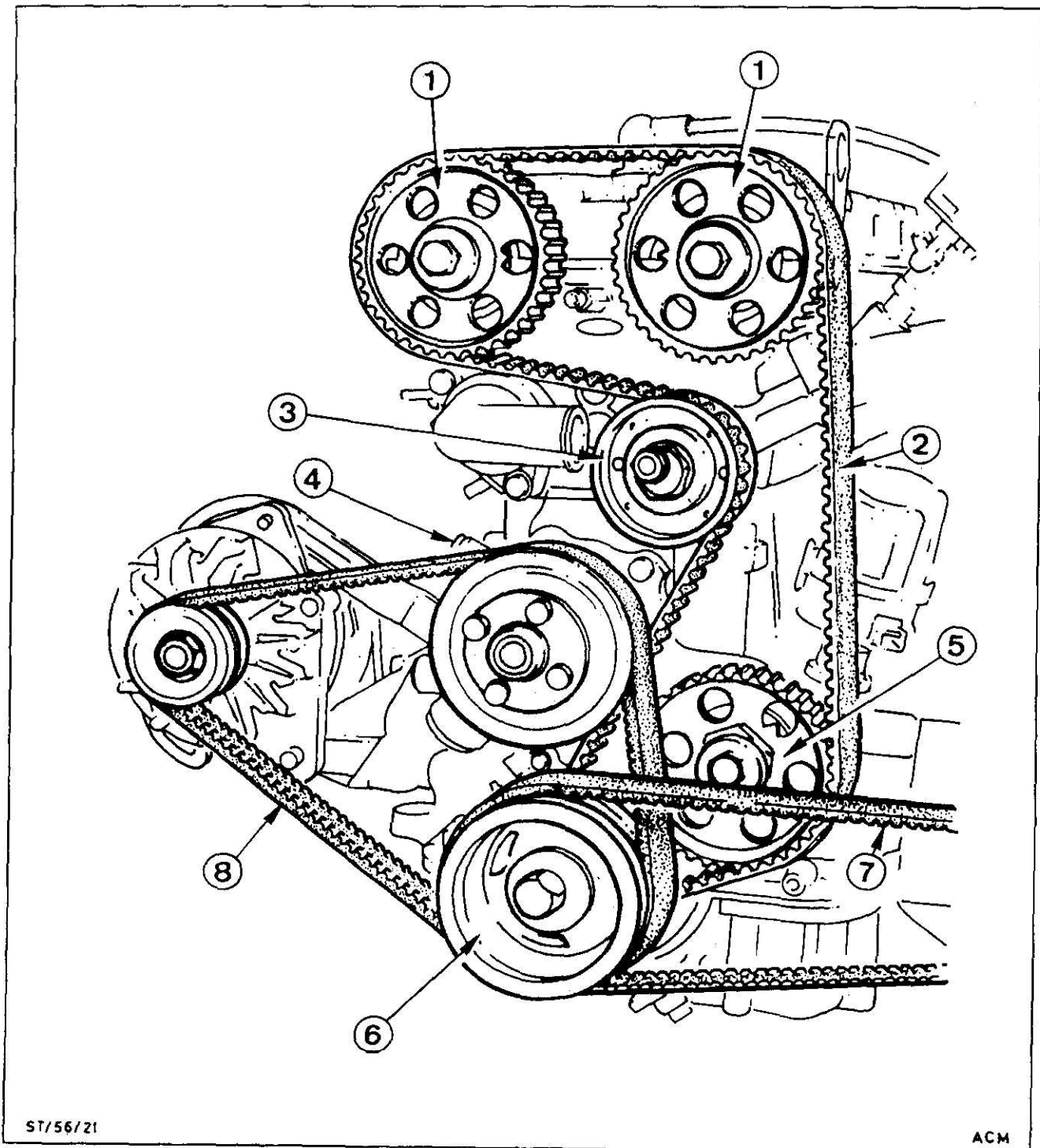

ST/56/21

ACM

- 1 = Camshaft sprocket gear
- 2 = Timing belt
- 3 = Tensioner – timing belt
- 4 = Water pump

- 5 = Sprocket gear – auxiliary shaft
- 6 = Three belt pulley
- 7 = V-belt – power steering pump
- 8 = V-belt – alternator and water pump

PART A – Engine, Engine Management and Turbocharger

1.1 Engine Components (Front Belt Drive, cont'd.)

- The overhead camshafts and the auxiliary shaft are driven by a toothed timing belt directly from the crankshaft sprocket gear. The timing belt must be replaced in service every 80.000 km (50.000 miles).
- The sprockets for the camshafts and the auxiliary shaft are located by keys.
- In contrast to the standard OHC-engine the Cosworth engine has a TDC marking on the sprocket gear for the auxiliary drive.
- The eccentric type belt tensioner allows a very precise setting of the timing belt tension.
- The fan belt pulley on the crankshaft drives three belts, a matched pair for the alternator and the water pump and a single belt for the power steering pump.
- Tensioning of the "V" belts for the alternator and the water pump is done on the bracket for the alternator. The procedure is similar to the one for the standard OHC-engine. Tension of the "V" belt for the power steering pump is achieved by tilting the power steering pump.

- There are 4 teeth on the "V" belt pulley nearest to the engine. These teeth are separated by exactly 90°. They initiate the pulses for the speed sensor (see "Engine Management").

The tooth next to the ignition timing mark identifies the TDC position of piston No. 1. This position is reached when the flank of the tooth aligns with the marking on the front cover (see illustration). The TDC position for the camshafts and the auxiliary shaft is set using the timing marks on the sprocket gears and the markings on the housing.

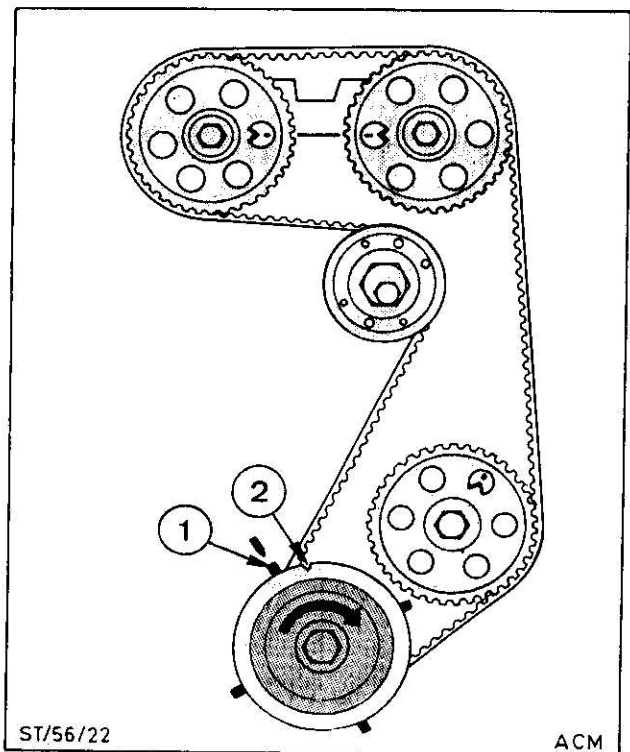

TDC Markings

- 1 = TDC position of cylinder "1"
- 2 = Ignition timing (16° BTDC)

PART A – Engine, Engine Management and Turbocharger

1.1 Engine Components

Crank Case Assembly

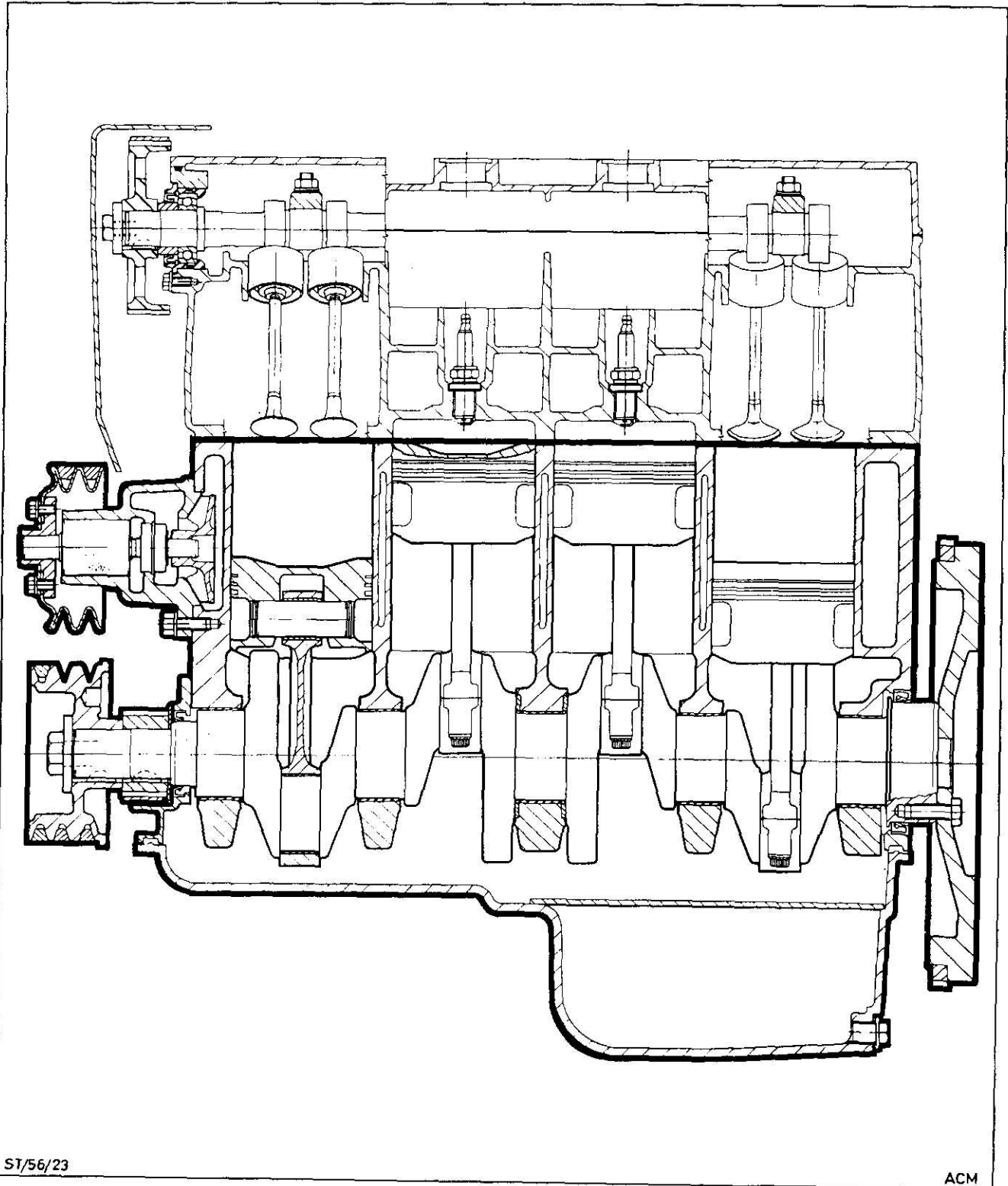

Engine – side cross section

PART A – Engine, Engine Management and Turbocharger

1.1 Engine Components (Crank Case Assembly, cont'd.)

Cylinder Block

- The cylinder block is a specially selected standard production OHC block.
- **Cylinder blocks selected have either a standard bore grade 2 or 3.**
- The bore size of the individual cylinders (either class 2 or 3) is stamped into the cylinder block behind the distributor, starting with cylinder No. 1.

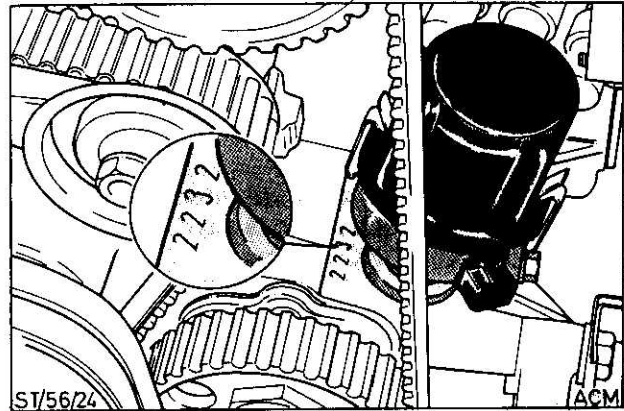

Identification of cylinder bores and piston grades

Crank Case Assembly

- The aluminium alloy pistons are either standard class 2 or 3.
- The pistons have a combustion bowl.
- The upper compression ring is chrome-plated. Both compression rings are marked "TOP".
- The piston pin is fully floating and secured by snap rings.

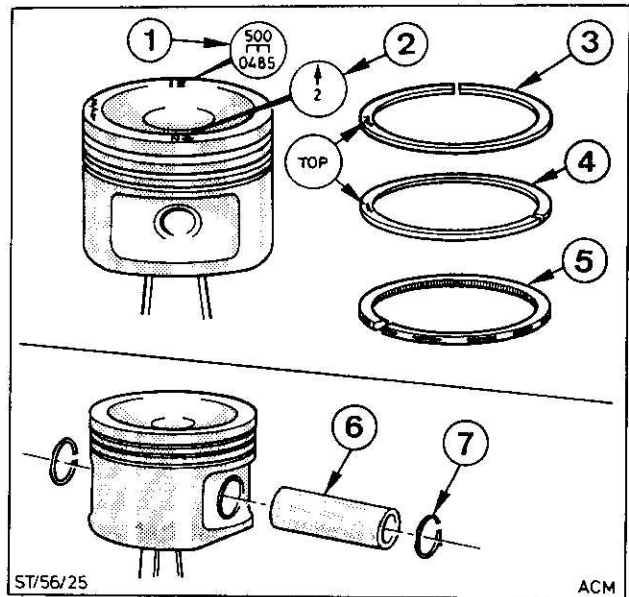

Piston, Piston Rings and Piston Pin

- 1 = Production date and Manufacturer sign
- 2 = Piston-standard class and arrow - engine front
- 3/4 = Compression rings with "TOP" mark
- 5 = Oil control rings
- 6 = Piston pin
- 7 = Snap ring

PART A – Engine, Engine Management and Turbocharger

1.1 Engine Components (Crank Case Assembly, cont'd.)

- The connecting rods have been redesigned to suit high performance engine.
- The crankshaft is dimensionally similar with the standard OHC crankshaft. However, the crankshaft is forged steel and bearing journals are specially hardened.
- The crankshaft is supported in five main bearings similar to the standard OHC engine. The centre main bearing is fitted with thrust half washers to control crankshaft endfloat, as on standard OHC engine.
- The main and connecting rod bearings are similar to the standard OHC engine but with improved bearing surface material. The procedure to measure bearing clearance is also similar. **Note:** The main bearing shells in the block have an oil groove.
- The crankshaft sprocket gear and the front and rear oil seals are similar to the standard OHC engine, but reinforced.
- Most special tools for removal and installation are also carry over from the OHC engine. The installation tool for the rear oil seal has two additional fastening holes to suit the revised hole circle in the flywheel.
- The flywheel is new and it is fastened to the crankshaft by 9 instead of 6 bolts. The diameter of the flywheel is approx. 25 mm larger than on the OHC engine (without ring gear).

The flywheel and the crankshaft are balanced together during manufacture. The correct position of the flywheel to the crankshaft is ensured by unequal spacings between the fastening holes. The space between the fastening holes "A" is smaller than between the others.

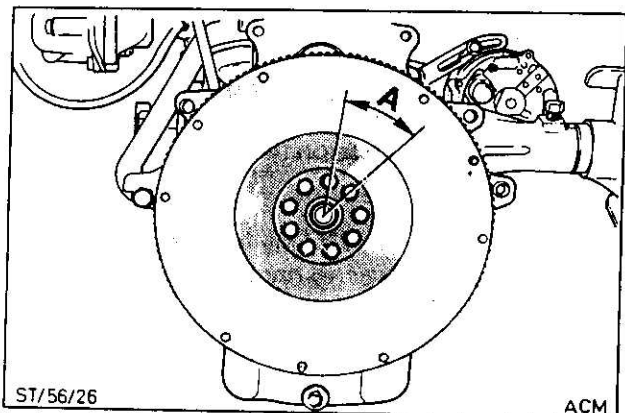

Hole circle in the flywheel

A = Smaller spacing

PART A – Engine, Engine Management and Turbocharger

1.1 Engine Components

Oilpump and Lubrication Circuit

- The oilpump is similar in design and operation to the pump fitted to the OHC engine.
- The cover of the pump has been revised to connect an additional oil pipe.

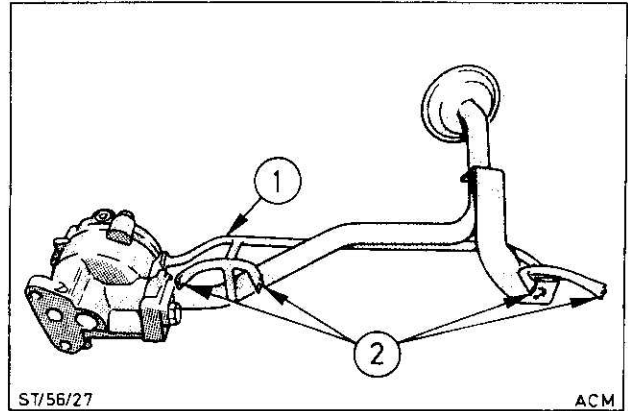

Oilpump

- 1 = Oilpipe
- 2 = Four spray pipes

- There are four spray pipes, one for each cylinder, which allow piston cooling by oil spray.

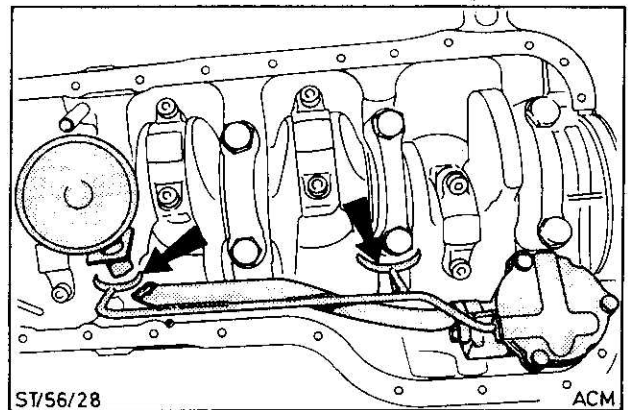

Position of the oilpump with spray pipe

- The oil pump draws oil from the sump and feeds it through an oil cooler and the full-flow filter into the main oil gallery which distributes the lubricant into the oil galleries in the same manner as on the standard OHC engine.

An oil gallery at the front end of the engine block feeds oil to the valve train and the hydraulic tappets.

A non return valve in the oil gallery of the cylinder head eliminates oil drain back after the engine is switched off.

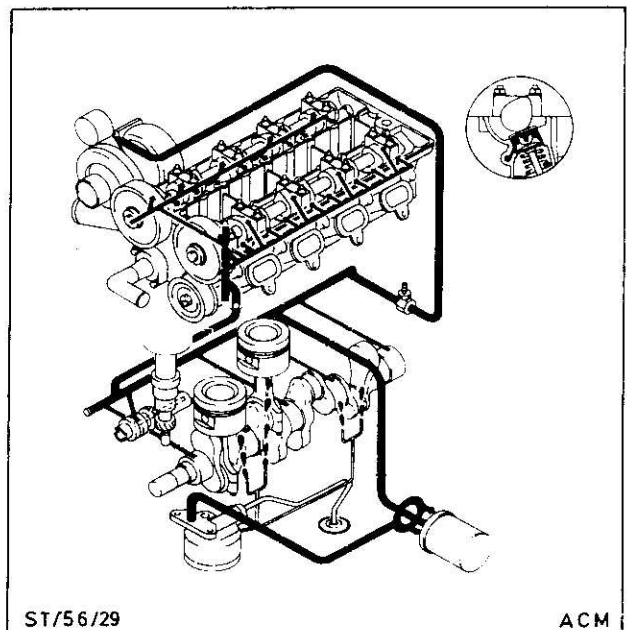

Lubrication circuit

PART A – Engine, Engine Management and Turbocharger

1.1 Engine Components

The Oilpan

- The Ford Cosworth engine has an aluminium oilpan with internal baffle plate.
- The gasket set for the oilpan is new. The gasket features two cork layers with an aluminium gasket sandwiched between them and 2 additional rubber gaskets.

Since the aluminium oil pan gives the engine block additional strength, the cork/aluminium gaskets must be used.

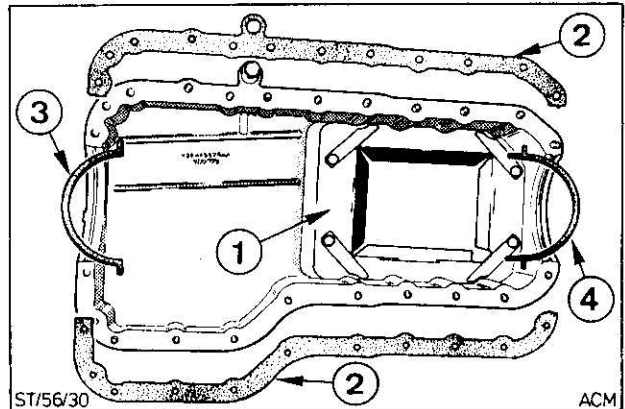

Oilpan and gasket

- 1 = Oil baffle
- 2 = Cork/aluminium gasket
- 3 = Front rubber gasket
- 4 = Rear rubber gasket

- The sealing wedges of the rear main bearing are part of the rubber seal and not separated as on the standard OHC engine.

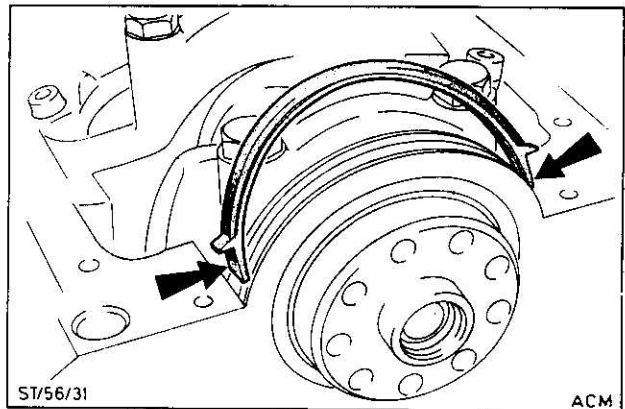

Rubber seal – rear main bearing

PART A – Engine, Engine Management and Turbocharger

1.1 Engine Components

Engine Crankcase Ventilation

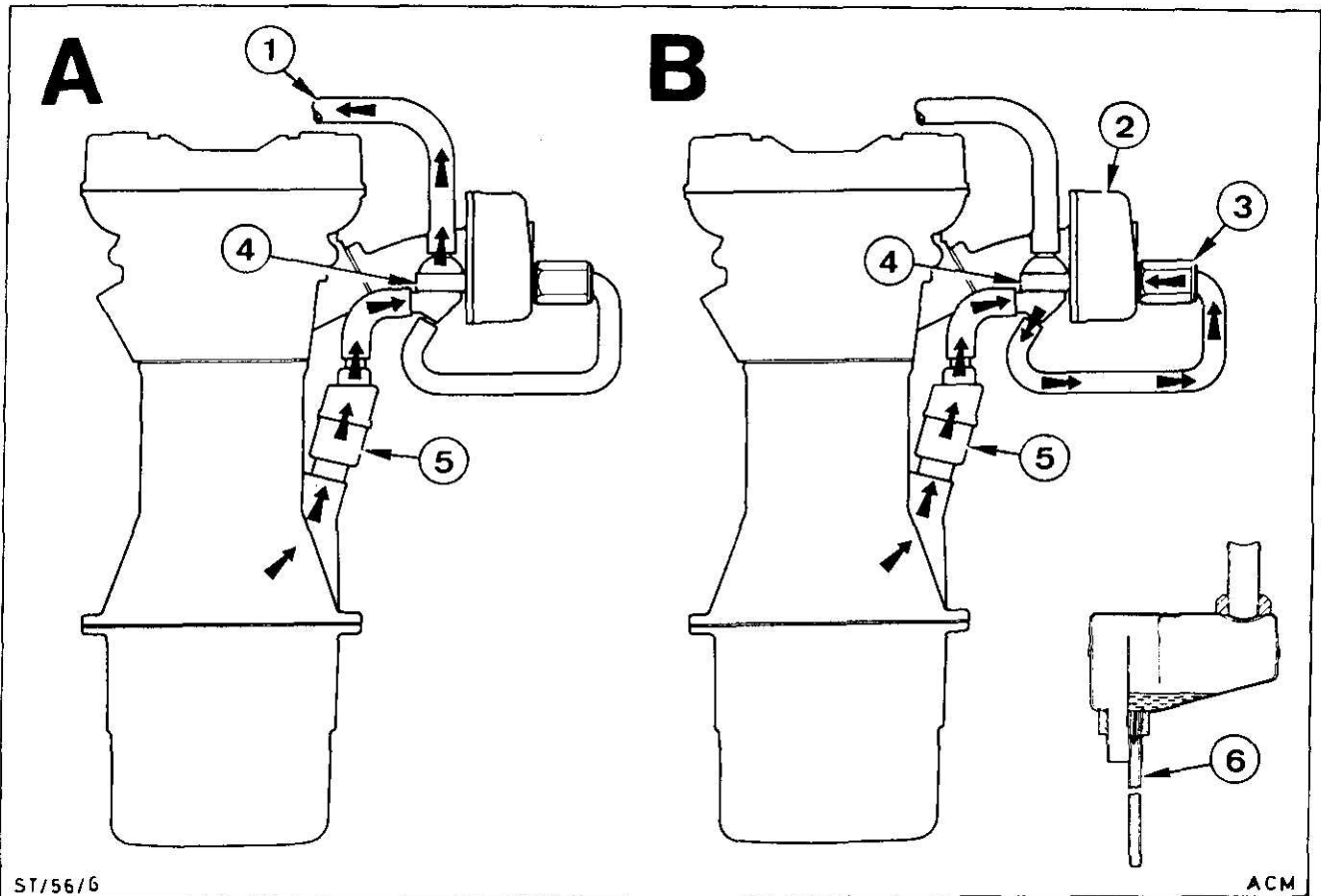

A = Throttle plate in fully open position

B = Throttle plate in closed position

1 = To aircleaner

4 = Filter

2 = Airchamber

5 = Oil separator

3 = Non return valve

6 = Oil drain pipe in oil separator

Waterpump and Thermostat Housing

- The water pump has been carried – over from the Sierra 2,0 Ltr. OHC engine.
- Connected to the thermostat housing are the bleed hose for the cooling system and the coolant feed pipe to the turbocharger.
- Thermostat nominal temperature rating: 88° C

Opening temperature: 88° ... 94° C

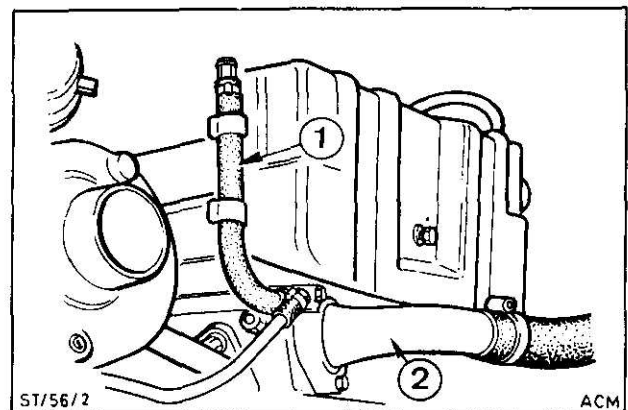

Thermostat Housing

1 = Bleed hose

2 = Connection for coolant feed pipe to turbocharger

PART A – Engine, Engine Management and Turbocharger

1.2 Repair Information

General

This part of the brochure covers some important points on repair procedures. Complete and detailed procedures like engine disassembling and assembling are covered in the Sierra RS Cosworth Workshop Manual.

Most of the special tools are already available from the standard OHC engine. Additional new special tools are detailed below.

New or modified special tools:

New Special Tools	Tool No.
Adaptor for valve spring compressor	21-024-06
Cylinder head alignment studs	21-128
Installer – valve stem oil seal (exhaust)	21-129
Installer – valve stem oil seal (intake)	21-130
Remover – fuel feed hose	23-023

Modified Special Tools	Tool No.
Crankshaft rear oil seal installer	21-011 D
Remover – crankshaft sprocket gear	21-028 A

PART A – Engine, Engine Management and Turbocharger

1.2 Repair Information

Important Notes on Cylinder Head – Removal and Installation

Note: Before slackening the head bolts the engine should be allowed approx. 2 hours to cool off.

- The fuel feedpipe can be removed using the new special tool 23-023.

Open special tool and slide over the fuel pipe as shown in illustration. Push tool against pipe fitting.

- Remove the timing belt cover. There are
 - two spacers fitted between the valve cover and the timing belt cover,
 - one spacer (with washer) screwed into the cylinder head
 - and one spacer screwed into the engine block.

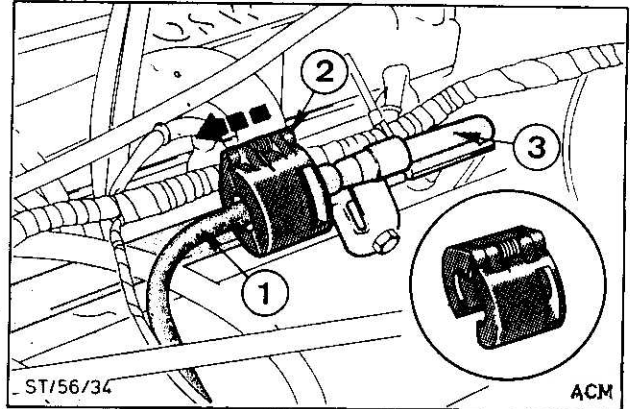

Removal of fuel feed pipe

- 1 = Fuel feed pipe
- 2 = Special tool 23-023
- 3 = Fuel rail

- Before removing the timing belt the first cylinder should be set to TDC as follows:
 - Turn crankshaft to a position where the flank of the tooth on the V-Belt pulley (1) aligns with the TDC marking on the cover.

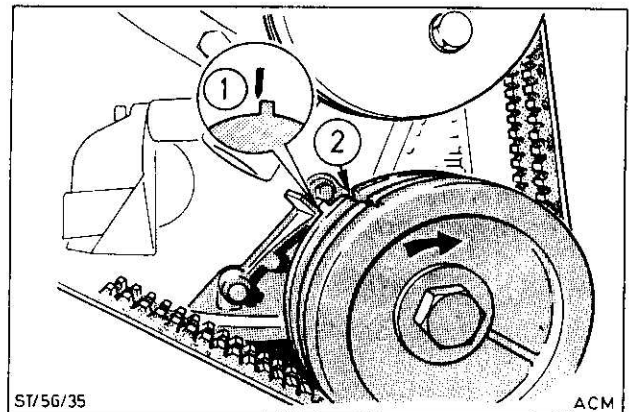

Crankshaft in TDC position

- 1 = TDC marking
- 2 = Ignition timing mark (16° BTDC)

- The timing marks of the two camshaft sprocket gears must align with the cylinder head upper edge.

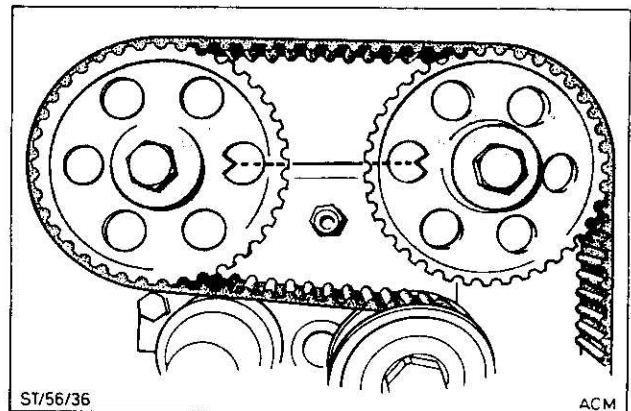

Camshafts in TDC position

PART A – Engine, Engine Management and Turbocharger

1.2 Repair Information (Important Notes on Cylinder Head – Removal and Installation, cont'd.)

- The timing mark on the sprocket gear for the auxiliary shaft must align with the marking on the engine block.

In this position, the distributor rotor will be in No. 1 TDC position.

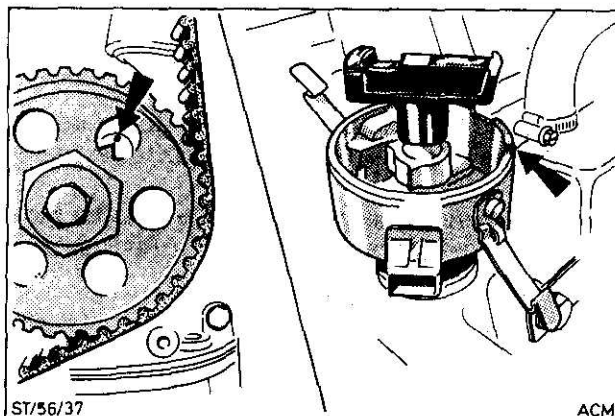

Auxiliary shaft and distributor rotor in TDC position

- Slacken timing belt tensioner (one nut) and remove timing belt.

Important: Do not crank the engine with the timing belt removed. This will cause serious damage to the valve train and the pistons.

- Slacken cylinder head bolts starting from the middle of the head. Remove bolts with washers.

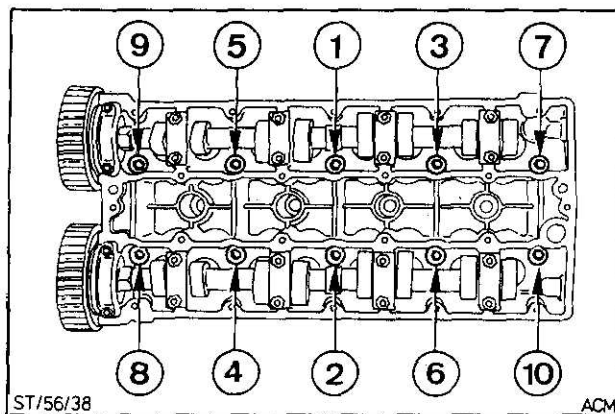

Slacking and tightening sequence for the head bolts

- When installing the cylinder head gasket fit alignment studs as shown.

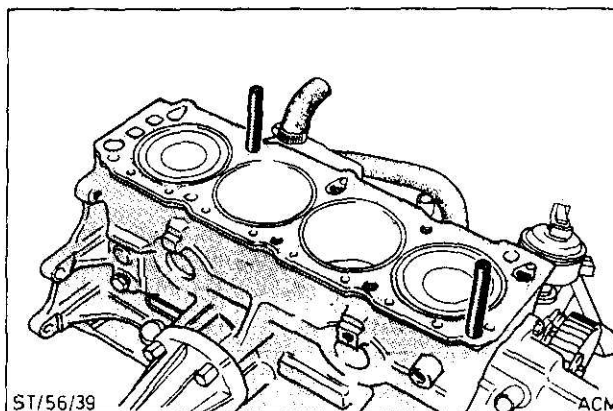

Alignment studs

PART A – Engine, Engine Management and Turbocharger

1.2 Repair Information (Important Notes on Cylinder Head – Removal and Installation, cont'd.)

- Lubricate head bolts at threads and under bolt head and install bolts together with washers. Tighten cylinder head bolts as follows.
Stage 1 requires to tighten all bolts 30–35 Nm.
Stage 2 requires to tighten all bolts to 67–70 Nm following the sequence.
Stage 3 requires the bolts to be tightened in degrees of rotating using a special gauge tool.
Following the sequence, each bolt is turned 80°–90° of rotation.

- Check and ensure that the crankshaft, the camshafts, the auxiliary shaft and the distributor rotor are still in TDC position. Fit the timing belt in counter – clockwise direction starting at the auxiliary gear.
- Pull belt tensioner by hand in clockwise direction against the timing belt and tighten fastening nut.
- Crank engine several times in clockwise direction and subsequently one full turn counter – clockwise to TDC position.

Note: The engine must not be cranked beyond TDC position.

- Using the belt tension gauge 21–113, check belt tension at the longest straight section (see illustration). If necessary adjust belt tensioner so that the specified tension of 9,5 to 10,5 is achieved.
- Repeat complete procedure and recheck belt tension.

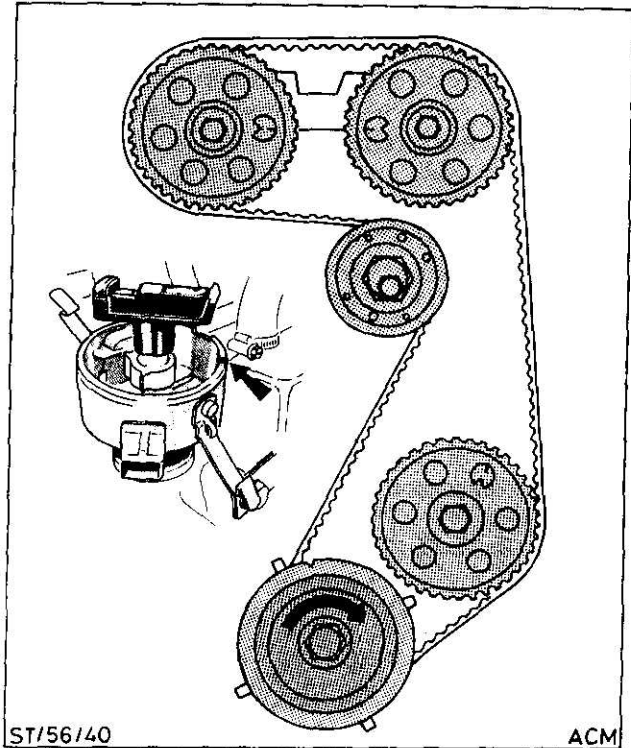

Crankshaft, camshafts, auxiliary shaft and distributor in TDC position

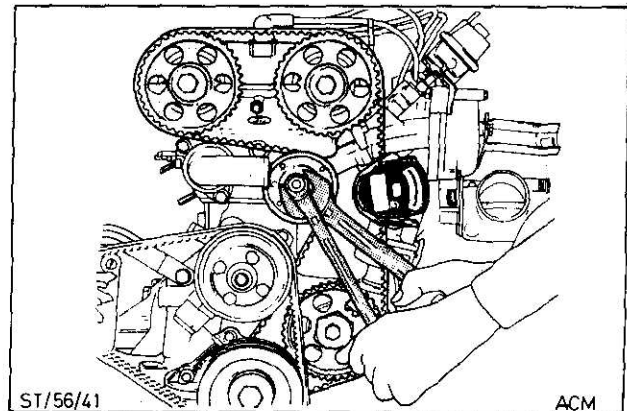

Checking and adjusting belt tension

- Fit valve cover using a new, dry gasket. Then finger tighten all bolts. Subsequently torque bolts to specification, beginning with the inner bolts and ending with the outer bolts. Then tighten the flange bolts to specification.
- Install timing belt cover making sure the spacers and washers are correctly installed.

PART A – Engine, Engine Management and Turbocharger

1.2 Repair Information

Cylinder Head – Important Notes on Disassembly and Assembly

- To remove the camshafts, untighten bearing caps carefully in equal steps, remove caps and then lift the camshafts from the supports.
- The bearing caps are marked by numbers starting at the front ball bearing 1 to 5 on the exhaust side and 6 to 10 on the inlet side.
- The bearing journals of the camshaft for the inlet side have oil grooves.

The camshafts must not be interchanged

- The bearing caps will fit one way only – incorrect installation is therefore not possible.

- When fitting the camshafts, make sure that the front bearing retainers are flush with the bore in the cylinder head. The bearing retainers are prevented from tilting by a screw and washer from below (see illustration).
- First fit bearing caps 2 to 5 and 7 to 10 and tighten them equally starting with the inner ones.
- Ensure both front bearing retainers are still flush before fitting the caps 1 and 6. Subsequently torque all nuts with the specified torque (see Technical Data).

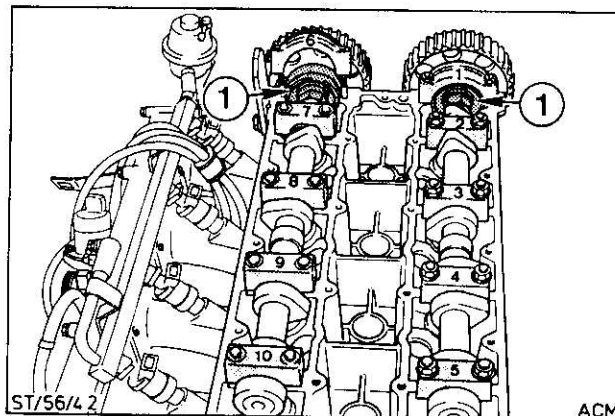

Identification of bearing caps

1 = Support with ball bearing

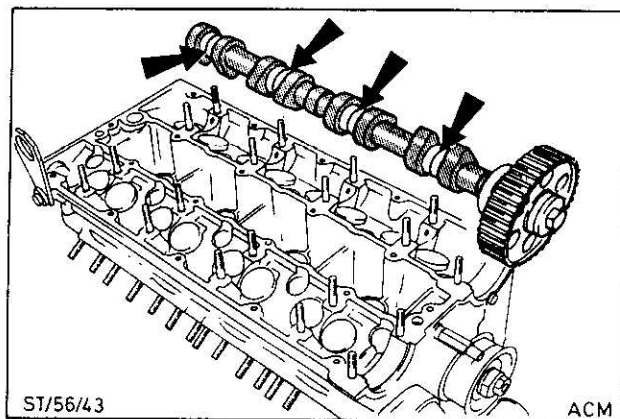

Camshaft for the inlet valves

Bearing journal with oil groove

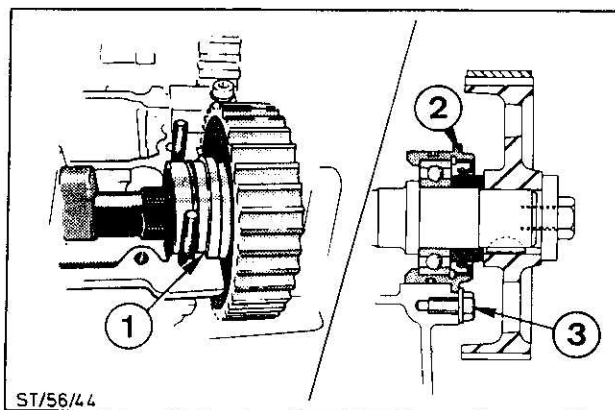

Camshaft front bearing

- 1 = Retainer in flush position
- 2 = Bearing retainer
- 3 = Securing screw

PART A – Engine, Engine Management and Turbocharger

1.2 Repair Information (Important Notes on Cylinder Head – Disassembly and Assembly, cont'd.)

The camshaft once removed from the cylinder head can be disassembled as follows:

- The camshaft sprocket gear is fixed on the camshaft by a keyway with key (8).
- Unscrew fastening bolt and remove the sprocket gear (1). Remove key (8) and pull oil seal race (2) and bearing retainer (6) from the camshaft (9).
- Leaver off oil seal (3) from the bearing retainer (6).
- The ball bearing (5) has a press – fit in the retainer (6) and is secured by a snap ring.
- The bearing can easily be pushed out of the retainer (if necessary with light hammer blow on the bearing outer ring or by using the handle of a hammer).
- New rubber 'O' rings (7) should be used when reinstalling the camshaft.
- The oil seal can also be replaced with the camshaft in situ. This requires removal of the sprocket gear and the oil seal race. Then, the oil seal can be removed using the special tool 21-096.
- The hydraulic valve tappets are supplied as an assembly and must not be dismantled.
- Removal of a hydraulic tappet can be done easily using a suitable sucker.

Note: Removal of hydraulic tappets should **not** be done with a magnet.

Tappets should not be mixed up and should always be installed in their original sequence.

- When installing, tappets should be lubricated.
- When applying pressure to the hydraulic plungers some tappets may feel "soft" due to air in their hydraulic chamber. This may be ignored because it will disappear once the engine is running again.

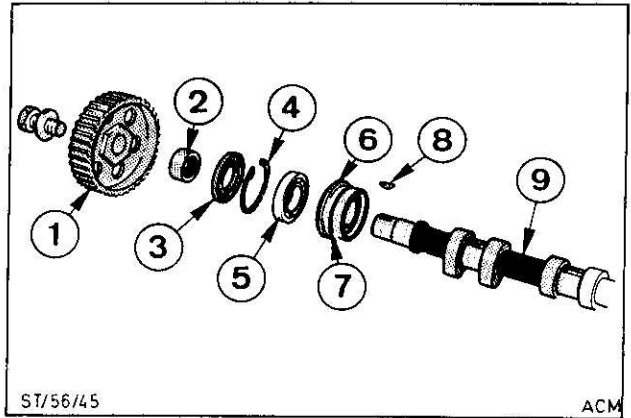

Camshaft assembly

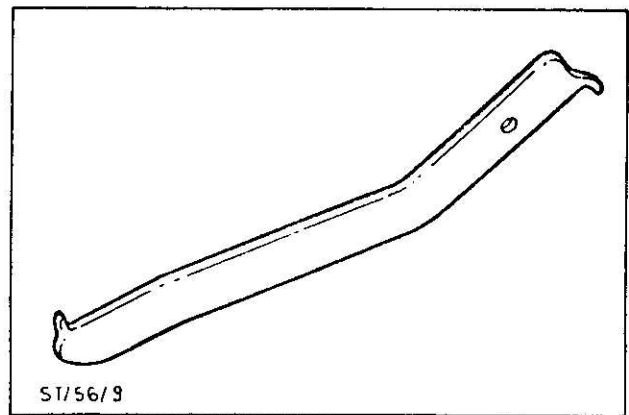

Special Tool 21-096

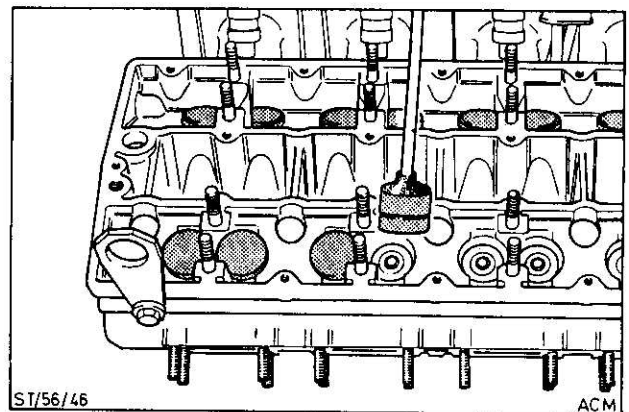

Removal of a hydraulic tappet

PART A – Engine, Engine Management and Turbocharger

1.2 Repair Information (Important Notes on Cylinder Head – Disassembly and Assembly, cont'd.)

- To remove the valves, the new adaptor 21-024-06 for the valve spring compressor 21-024 must be used. Make sure that the valves stems are not damaged by the valve spring retainer when it is pressed down to remove or install the valve collets.
- Remove the valve retainers, the springs and the valves.

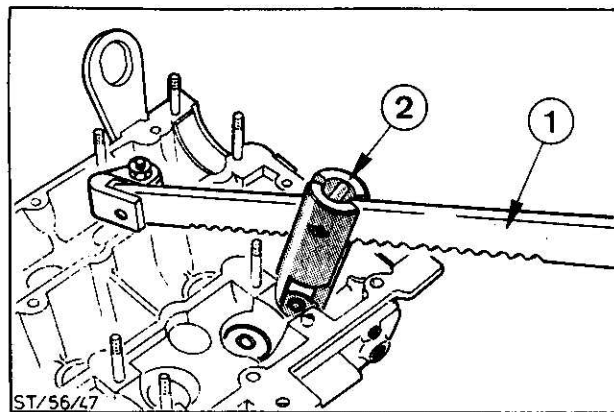

Removal of valves

- 1 = Valve spring compressor 21-024
- 2 = Adaptor 21-024-06

- Remove the valve stem seals using a suitable tool (as known from the 1600 Diesel engine) as shown. Subsequently remove the lower spring retainer.

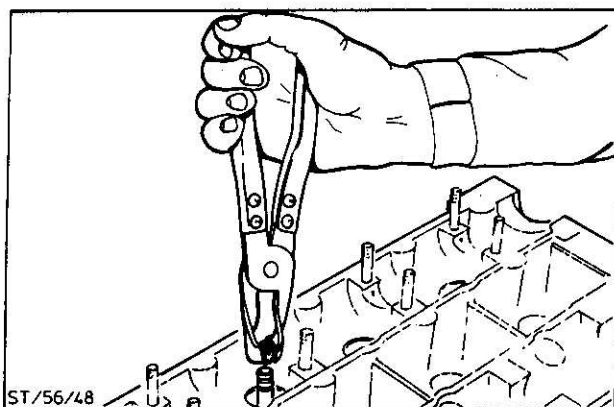

Removal of valve stem seals

- When assembling, first fit the lower spring retainers.
- Then lubricate the new valve stem seals and press them onto the valve guides using the special tool 21-130 for the inlet side and the special tool 21-129 for the outlet side as shown.

Please remember, that the valve stem seals have different diameters (inlet side – 7,0 mm, outlet side – 8,0 mm).

- Lubricate the valve stems before inserting the valves into the valve guides.

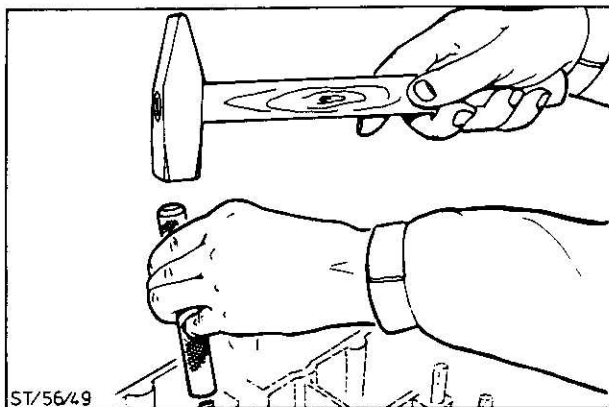

Installation of valve stem seals

- In the case of replacing the valve stem seals with cylinder head in situ, a suitable adapter for the pressure hose should be used.

Note: For this procedure crank engine by hand, that all pistons are in the same position in the cylinder bores and then lock the crankshaft.

PART A – Engine, Engine Management and Turbocharger

1.2 Repair Informations

Further important Repair Notes

- The crankshaft V-belt pulley, the thrust washer and the sprocket gear can be pulled off the crankshaft by hand. If the sprocket gear has a tight fit the special tool 21-028 A should be used.
- When fitting the sprocket gear the tapered side of the gear should face the camshaft. The V-belt pulley should be fitted with its teeth closest to the engine.
- The thread of the fastening bolt for the auxiliary shaft gear is plastic coated. When reinstalling always use a new bolt.

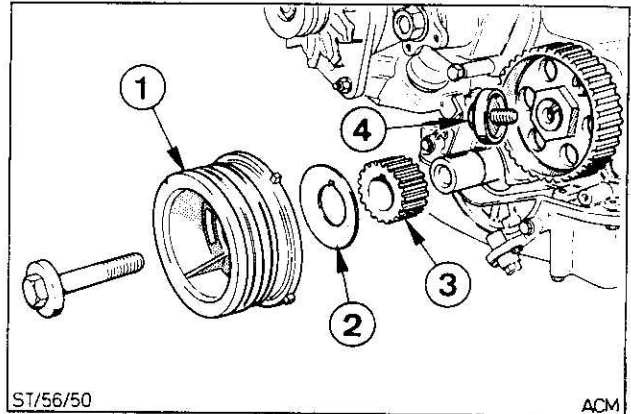

- 1 = V-belt pulley with teeth
- 2 = Thrust washer
- 3 = Crankshaft sprocket gear
- 4 = Fastening bolt-auxiliary shaft gear.
Bolt thread is plastic coated.

- The flywheel is balanced together with the crankshaft. The position of the flywheel to the crankshaft is fixed through unequal spacings between bolt holes i.e. the space "A" between two holes is smaller than between the others.
- The installer for the crankshaft rear oil seal is from the tool set for the standard OHC engine. However, the tool has two additional fastening holes to suit the revised bolt hole circle.

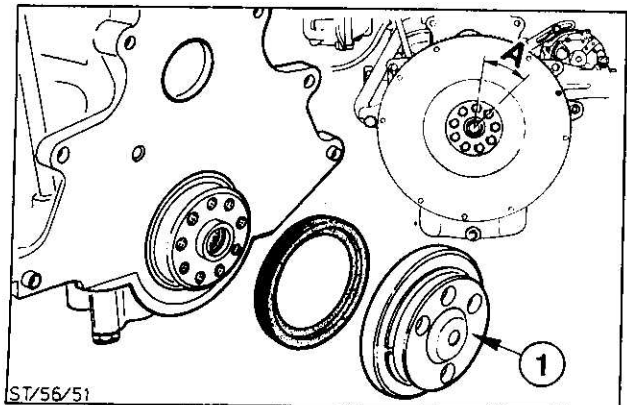

Flywheel fastening to crankshaft

- A = Reduced spacing
- 1 = Special tool with two additional fastening holes

PART A – Engine, Engine Management and Turbocharger

1.2 Repair Informations (Further important Repair Notes, cont'd.)

- Crankshaft bearing clearance should be measured using “Plastigage” as on the standard OHC engine.
- The main bearing caps are marked with an arrow which should point to the front of the engine.

- The rear main bearing cap is chamfered on both sides to ensure correct seating on the cylinder block. When installing the bearing cap, the chamfered edge should be coated with sealer (Loctite 518). Make sure the sealer is not applied to the flat contact area.

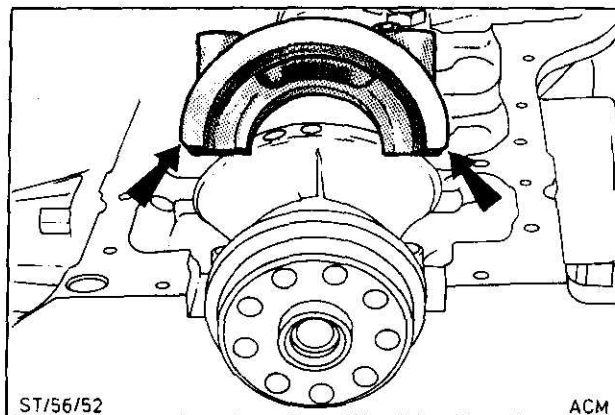

Rear main bearing cap

Sealer to be applied only to the chamfered edge.

- Crankshaft endfloat is controlled by thrust half washers. Their respective position must be marked when removing.
- The connecting rod big ends and -bearing caps are numbered. These numbers should be noted before removing the bearing caps and the caps should always be installed in their original position.
- When installing the pistons to the connecting rods the arrow on the piston crown must point to the front of the engine. The bearing retainer groove in the connecting rod should point to the auxiliary shaft.

PART A – Engine, Engine Management and Turbocharger

1.2 Repair Informations (Further important Repair Notes Other Repairs, cont'd.)

- Before installing the oil pump, fit the oil pump driveshaft. The longer end of the shaft should point to the distributor (see illustration).
- Fit oil pan gasket as follows:
Coat sealing wedges with sealer (Loctite 518, see illustration), insert them into the groove of the rear main bearing cap and press them fully home.
- Apply sealer to the ends of the front rubber seal and the cork gasket and install. Slide the ends of the cork gasket under the ends of the rubber gasket.
- Coat the threads of the oil pan fastening bolts with Loctite 270 and tighten them in three stages to the specified torque (see technical data).

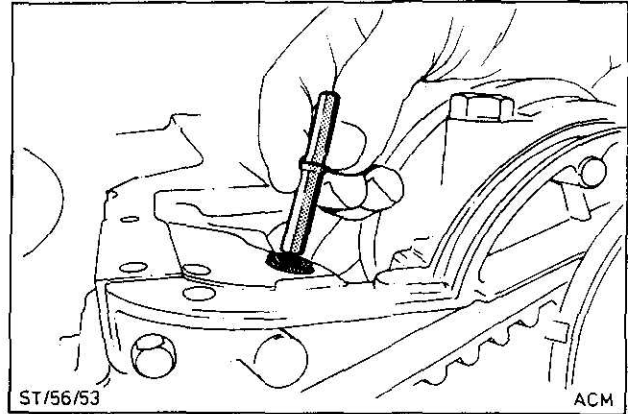

Oil pump driveshaft

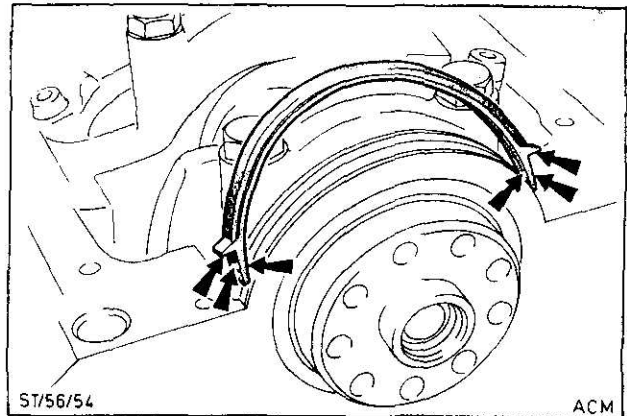

Coat sealing wedges with sealer

- If the distributor was removed, installation should proceed as follows:

– Hold distributor so that the spring clip points to the engine and that the distributor rotor points away from the engine (see illustration).

– When inserting the distributor the rotor will turn to its correct position and point to the marking for cylinder No. 1

Note: When installing the distributor, the crankshaft, the camshafts and the auxiliary shaft must all be in TDC position.

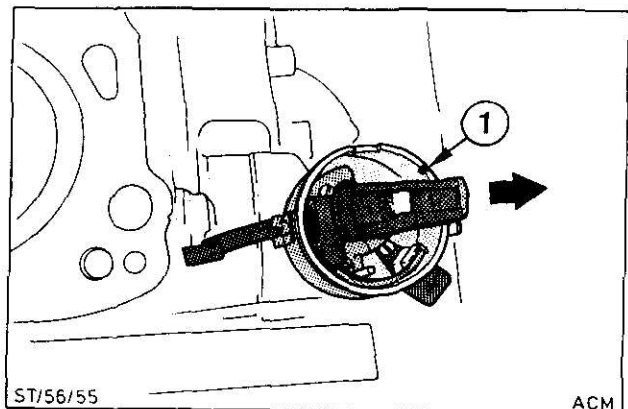

Position of the distributor rotor when installing the distributor

1 = Marking cylinder No. 1

PART A – Engine, Engine Management and Turbocharger

2. Electronic Engine Management

2.1 General Description

The Sierra Cosworth is fitted with a combined Electronic Engine Management System with fuel injection from Weber and ignition system from Marelli.

The electronic fuel injection system is in many respects very similar to the EFI system available for Scorpio and Sierra vehicles.

- An electric fuel pump feeds fuel from the fuel tank through a fuel filter to the fuel rail with its four injectors (one per cylinder).
- The injector "on" time is individually controlled for **each** cylinder by the Electronic Control Unit ECU.
- Inlet air passes from the aircleaner through the turbocharger, the air to air charge cooler, the throttle body, the airchamber and inlet manifold to the individual cylinders.

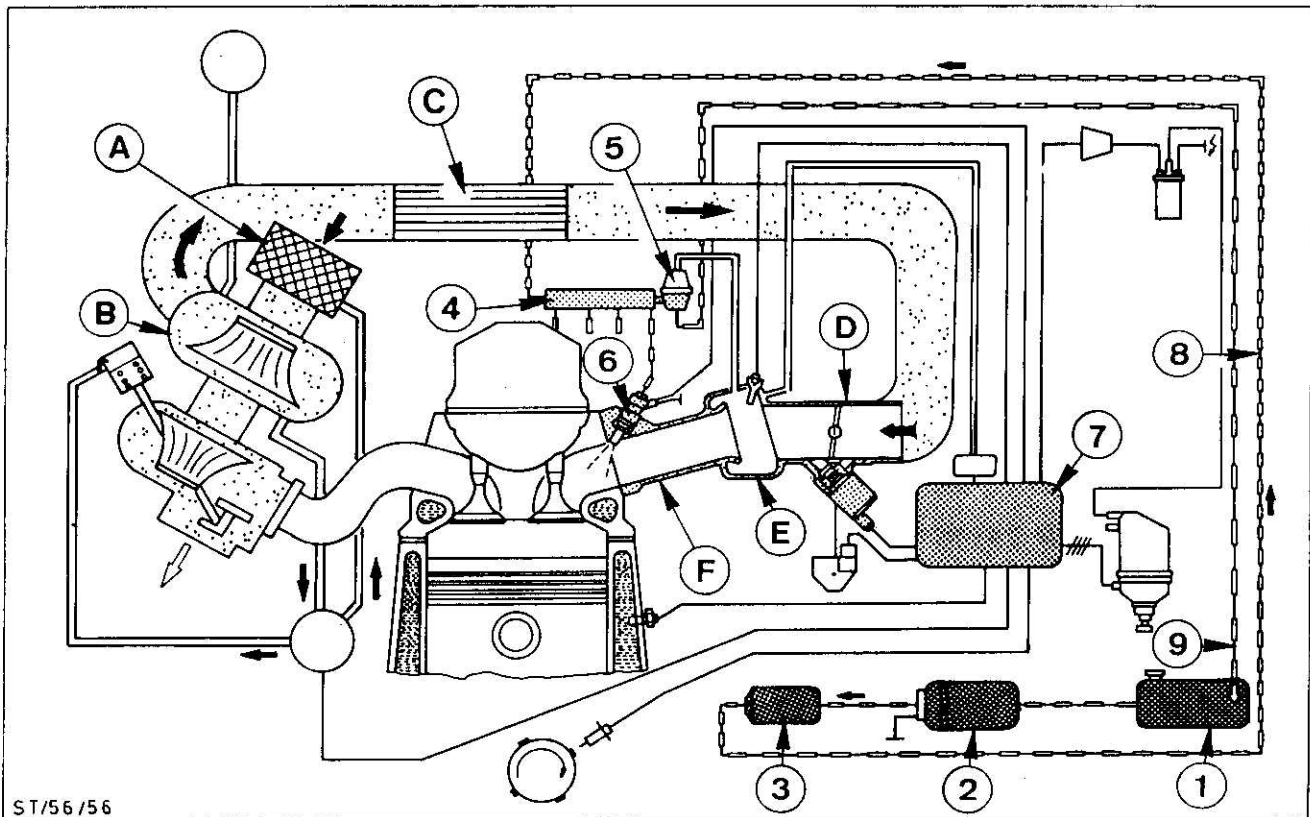

Electronic Engine Management – Fuel and Air System

- | | |
|-----------------------------------|--|
| 1 = Fuel tank | A = Air cleaner |
| 2 = Fuel pump | B = Turbocharger |
| 3 = Fuel filter | C = Air to air charge cooler (intercooler) |
| 4 = Fuel rail | D = Throttle body |
| 5 = Pressure regulator | E = Air chamber |
| 6 = Fuel injector | F = Inlet manifold |
| 7 = Electronic Control Unit (ECU) | |
| 8 = Pressurised fuel | |
| 9 = Non-pressurised fuel | |

PART A – Engine, Engine Management and Turbocharger

2. Electronic Engine Management

2.1 General Description (cont'd.)

The ignition is of the inductive discharge type with dwell control in the ignition module and the advance curves are stored by the ECU.

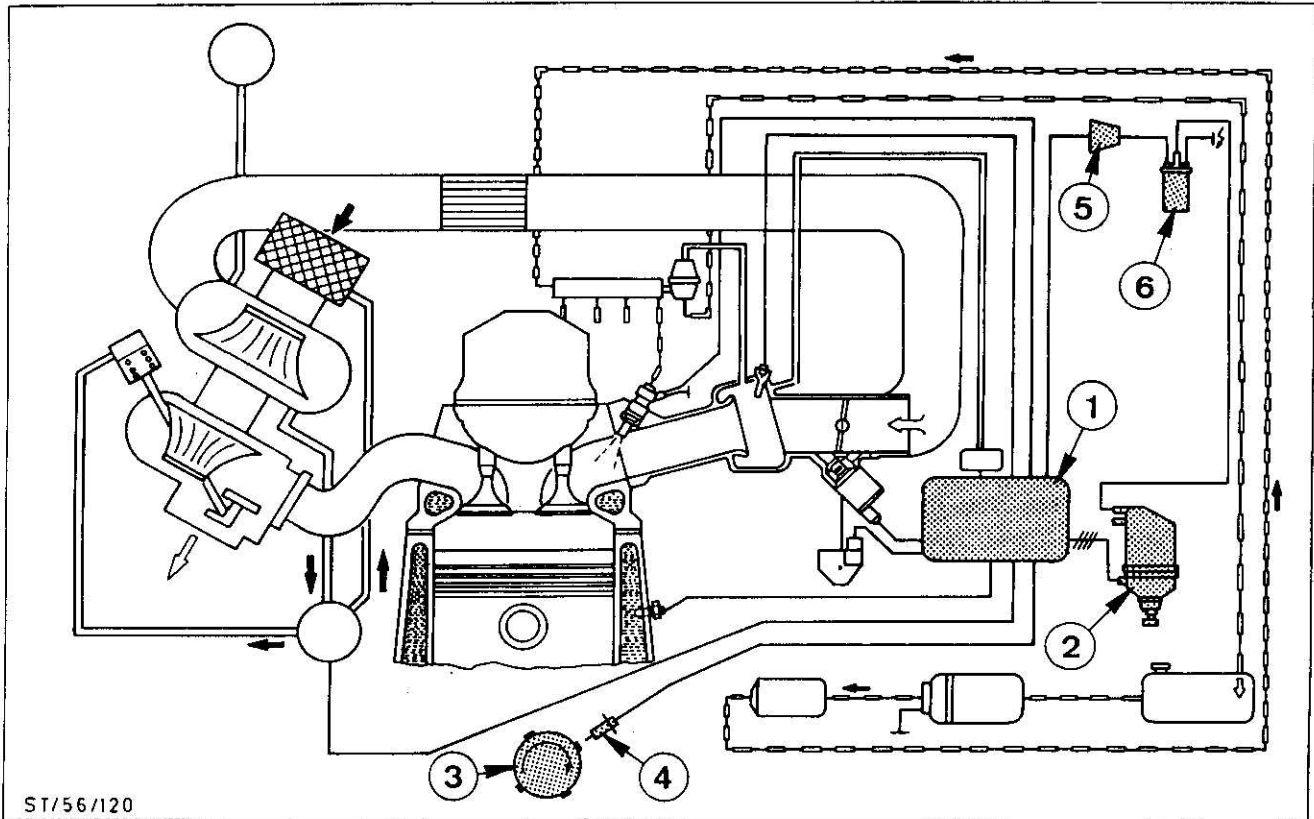

Electronic Engine Management – Ignition System

- 1 = Electronic Control Unit (ECU)
- 2 = Distributor with Phase sensor
- 3 = Crankshaft pulley

- 4 = RPM/TDC-Sensor
- 5 = Ignition module
- 6 = Ignition coil

A number of sensors feed a continuous stream of information signals to the ECU module thereby enabling the ECU to determine the required air fuel ratio and the spark timing.

The individual components of the engine management system are described on the following pages.

PART A – Engine, Engine Management and Turbocharger

2. Electronic Engine Management

2.2 System Components – Fuel System

The Fuel Pump

- The electric fuel pump is of roller type and is controlled by the ECU.
- The pump incorporates a non-return valve which can be replaced in service.
- The non-return valve maintains the system pressure during cranking.
- Fuel pump operation is controlled by a relay which switches the pump on and off when the engine is started or stalls.
- The pump cannot be repaired and must be replaced as a unit when defective.
- Both, the power relay for the ECU and the fuel pump relay as well as the Fuses are located in a special box in the engine compartment.

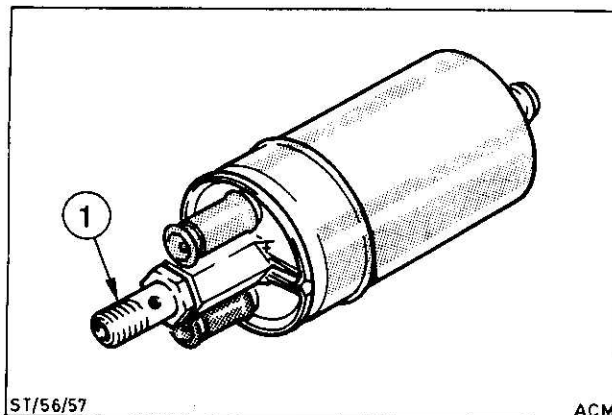

Fuel pump
1 = Non-return valve

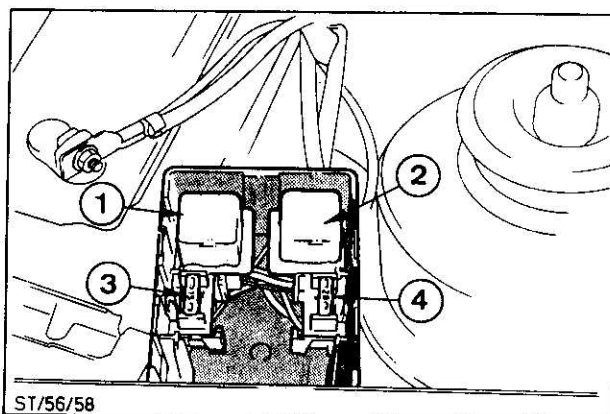

Relay location

1 = Power relay (brown socket)	3 = Fuse – Power relay 15 A
2 = Fuel pump relay (yellow socket)	4 = Fuse – Fuel pump relay 20 A

The Fuel Filter

- All fuel passes through a fuel filter. The filter must be replaced at regular intervals as detailed in the service voucher booklet.

The Fuel Rail

- All fuel from the filter passes to the fuel rail which is connected to all the injectors and ensures that they are supplied with fuel at the same pressure.

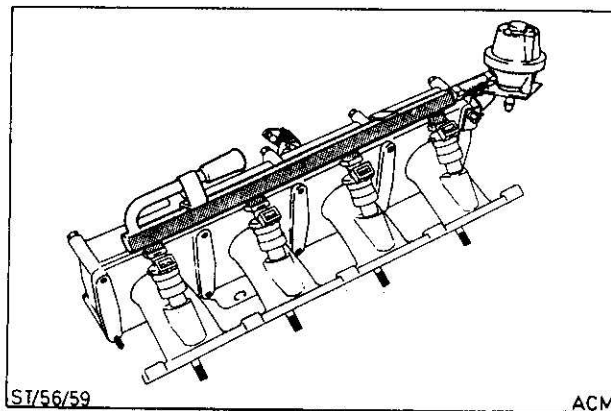

Fuel rail and pressure regulator

PART A – Engine, Engine Management and Turbocharger

2. Electronic Engine Management

2.2 System Components – Fuel System (cont'd.)

The Pressure Regulator

- To ensure accurate fuel metering and extend the capacity of the injectors it is necessary to reduce the fuel rail pressure at idle and low power usage whilst increasing the fuel rail pressure under boost conditions. This is achieved by feeding an inlet manifold pressure signal to the fuel pressure regulator.

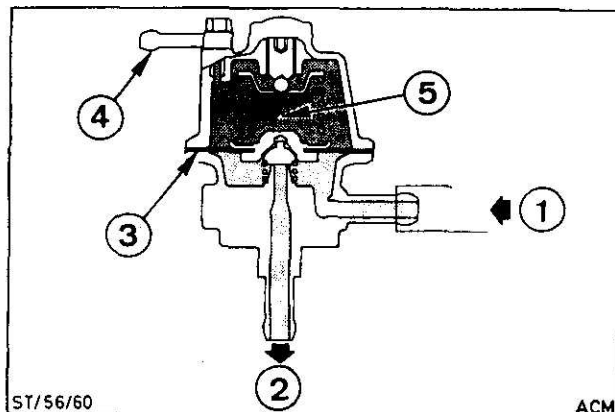

Pressure regulator cross section

- | | |
|-------------------------|--|
| 1 = Fuel from fuel tank | 4 = Connection – inlet manifold pressure |
| 2 = Fuel return | 5 = Inlet manifold pressure |
| 3 = Diaphragm | |

The Fuel Injector

- The injectors are solenoid operated valves.
- The quantity of fuel injected depends only on injector open time and fuel rail pressure.
- Injection is in a cone shape and the feed pressure 3,0 bar (modified by manifold pressure acting on the diaphragm of the pressure regulator), sufficient to cause a very fine spray.
- Injectors cannot be adjusted or repaired and have to be replaced as a unit when defective.

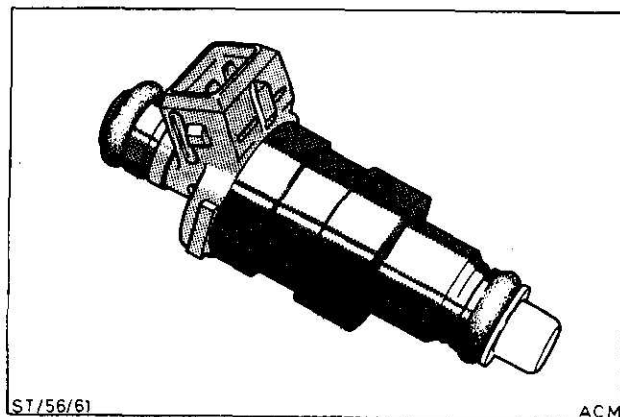

Fuel injector

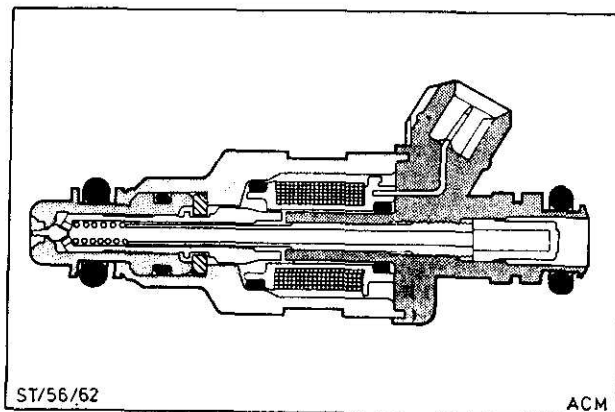

Fuel injector cross section

PART A – Engine, Engine Management and Turbocharger

2. Electronic Engine Management

2.2 System Components – The Air System

The Air Cleaner

- The air cleaner has a replaceable filter cartridge which can easily be removed in service.

The Throttle Body

- The throttle body (4) includes the throttle plate. The throttle plate setting screw (5) is factory set and sealed. It should not be altered in service. If the engine idle speed is not to specifications at the first servicing (1500 km), it can be adjusted by means of the basic idle speed control screw (see "Service Adjustments").
- Bolted on to the throttle body are the idle speed control valve (8) and the throttle position sensor (7). These are explained in the section covering "Sensors and Actuators".

The Air Chamber and Inlet Manifold

- The throttle body is bolted on to the air chamber (3). Also fitted to the air chamber are
 - the inlet air temperature sensor (11),
 - the vacuum connector for the Manifold Absolute Pressure sensor (9),
 - the vacuum connector for the fuel pressure regulator (10),
 - the vacuum connector for the aircharge by-pass valve (13),
 - and the vacuum connector for the crankcase ventilation filter (12).
- The air chamber is bolted on to the inlet manifold (2). The fuel rail with the plug-in fuel injectors (1) are fitted to the inlet manifold.

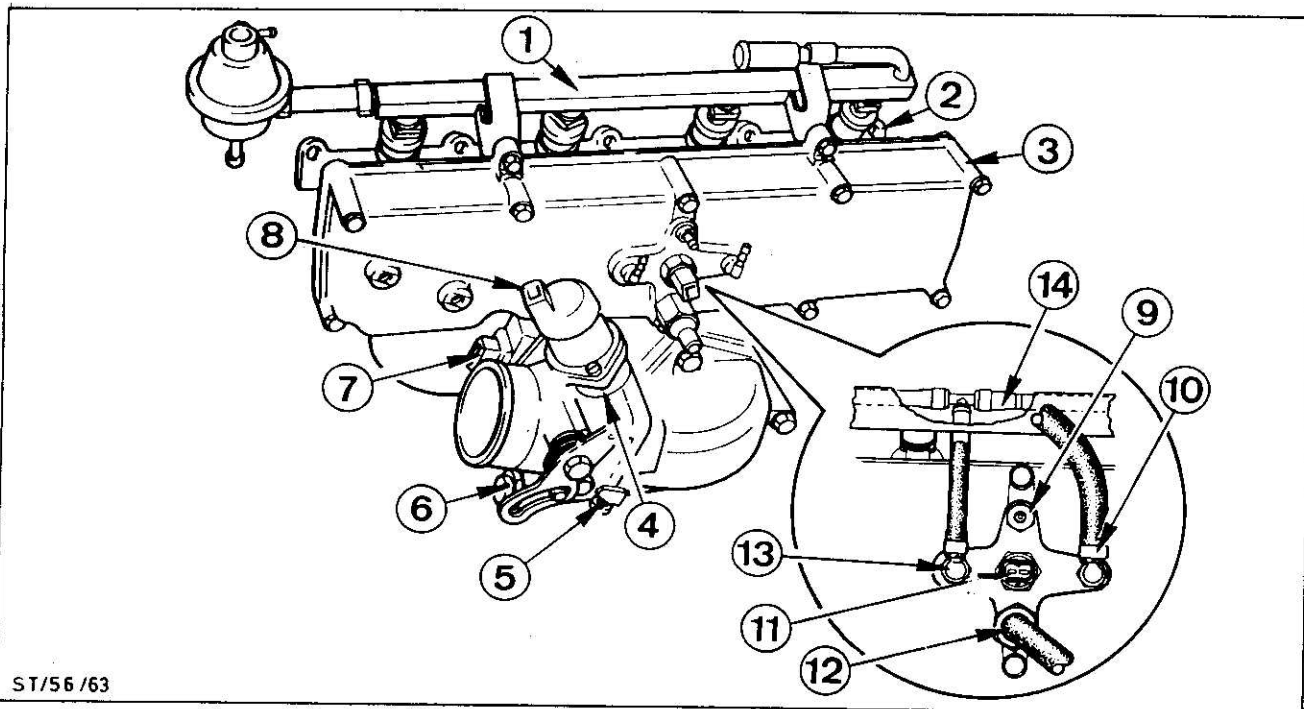

ST/56 /63

1 ⇒ Fuel rail with injectors

2 = Inlet manifold

3 = Air chamber

4 = Throttle body

5 = Throttle plate setting screw

6 = Basic idle speed control screw

7 = Throttle position sensor

8 = Idle speed control valve

9 = Connector – manifold absolute pressure sensor

10 = Connector – fuel pressure regulator

11 = Inlet air temperature sensor

12 = Connector – crankcase ventilation filter

13 = Connector – aircharge by-pass valve

14 = Connection – boost pressure gauge

PART A – Engine, Engine Management and Turbocharger

2. Electronic Engine Management

2.2 System Components – The Ignition System

The Distributor

- The distributor – make Marelli – is driven by the auxilliary shaft as on the standard OHC engine.
- A Phase sensor, located opposite a cam having two teeth separated at 90° to each other, is fitted inside the distributor. At the passing of a tooth the sensor delivers a signal to the ECU. This signal is similar to the signal supplied by an RPM/TDC-sensor fitted at the crankshaft pulley
- Both the signal from the distributor and the RPM/TDC-sensor enable the module to identify the phase of each cylinder. This information forms the basis on which the ECU module decides on spark timing and fuel injection.

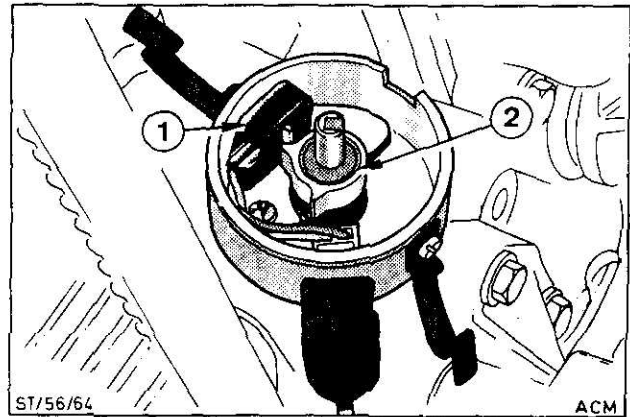

Distributor

- 1 = Phase sensor
- 2 = Cam with two teeth

The Ignition Coil and Ignition Module

- The Motorcraft ignition coil and the ignition module (make Marelli) are both fitted to the left fender apron
- The ECU sends a Spark-out (SPOUT) signal to the ignition module to trigger an H.T. pulse by switching the coil primary circuit off.

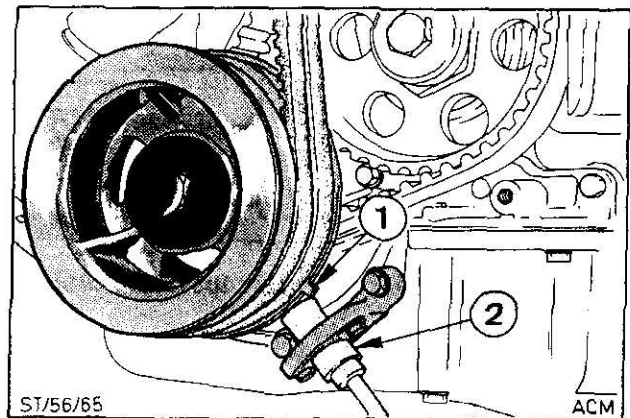

RPM/TDC-Sensor

- 1 = Tooth on crankshaft pulley
- 2 = Sensor

The Spark Plugs

- The Sierra RS Cosworth is fitted with Motorcraft spark plugs AGPR 901 C.

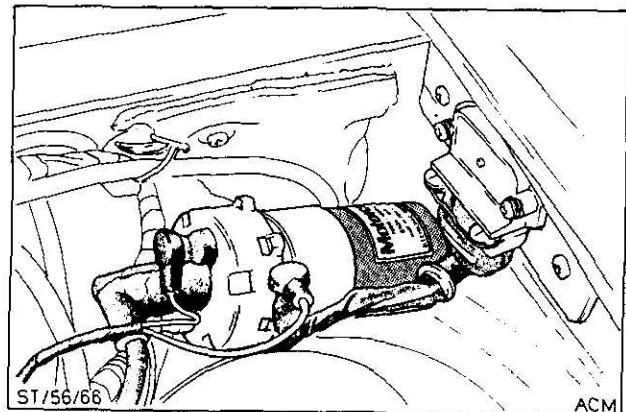

Ignition Coil and Ignition Module

PART A – Engine, Engine Management and Turbocharger

2. Electronic Engine Management

2.3 System Sensors and Actuators

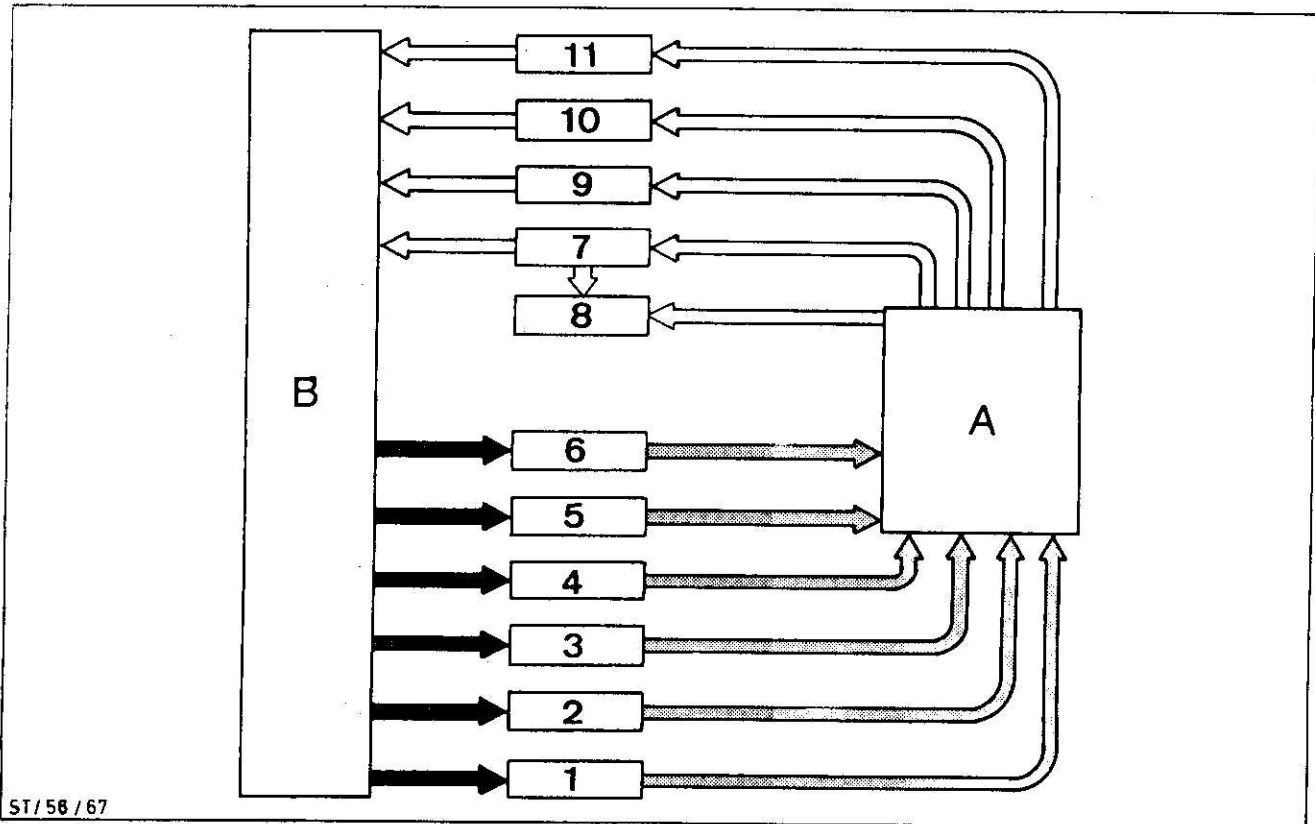

System Sensors (input) and Actuators (outputs)

A = ECU
B = Engine

Sensors

- 1 = Throttle Position Sensor (TPS)
- 2 = Manifold Absolute Pressure Sensor (MAP)
- 3 = Air Charge Temperature Sensor (ACT)
- 4 = Engine Coolant Temperature Sensor (ECT)
- 5 = Engine RPM/TDC-Sensor
- 6 = Distributor-Phase Sensor

Actuators

- 7 = Fuel Pump
- 8 = Fuel Injectors
- 9 = Idle Speed Control Valve (ISC)
- 10 = Boost Pressure Control Valve
- 11 = Ignition Modul

PART A – Engine, Engine Management and Turbocharger

2. Electronic Engine Management

2.3 System Sensors and Actuators

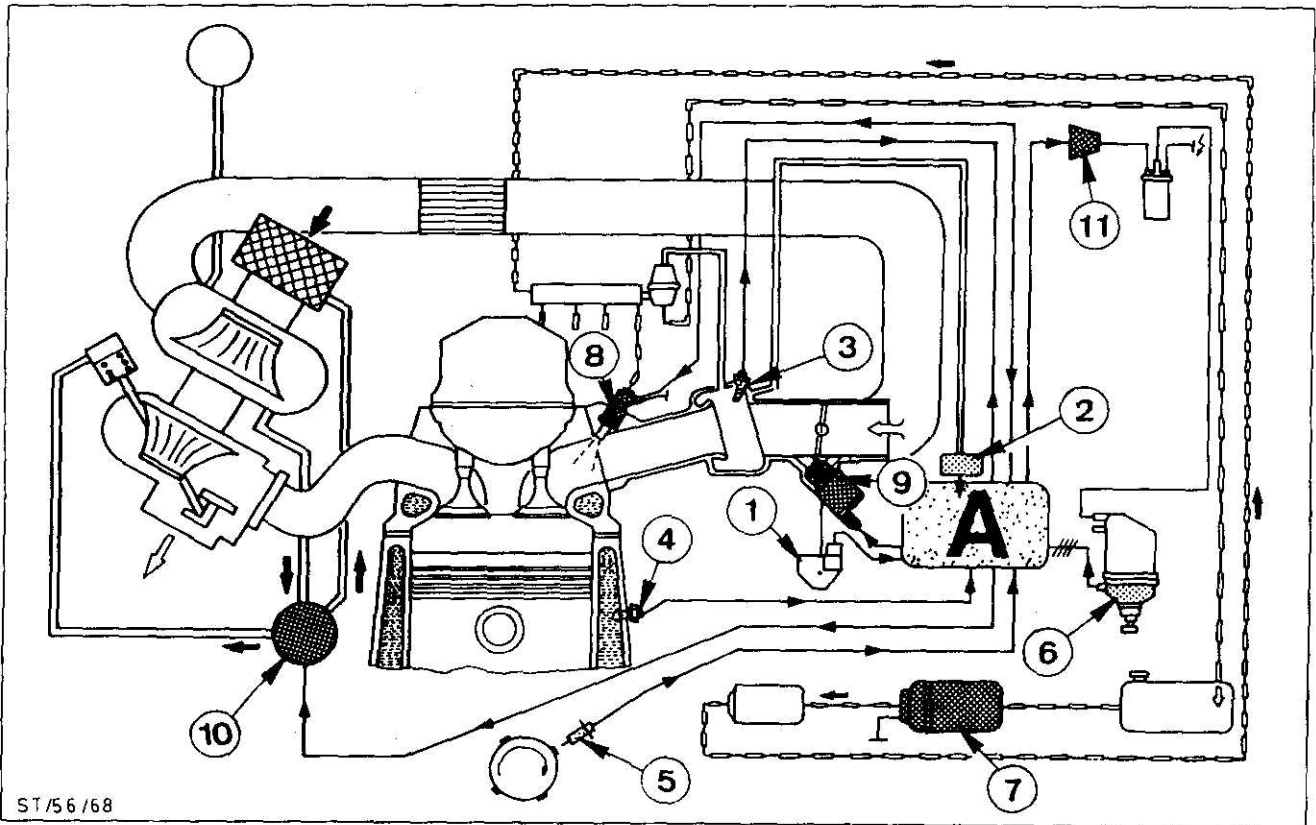

General Description

- The ECU module controls all fuel and ignition requirements of the engine by receiving, computing and comparing sensor signals with its own permanent memory. Then it sends out signals to a series of actuators which control spark timing and fuel release.
- The ECU is fitted behind the glove box and can be reached easily through a separate access lid. A 35 pin plug connects the ECU to the wiring loom.
- Power to the ECU is supplied with a feed from the battery, via a relay.
- Located next to the module are:
 - the CO adjusting screw,
 - a green, a blue and white cable for retarding the spark timing to meet fuels with lower octane rating
 - and a self test connector.

For details see "Maintenance, Service Adjustments and System Checks".

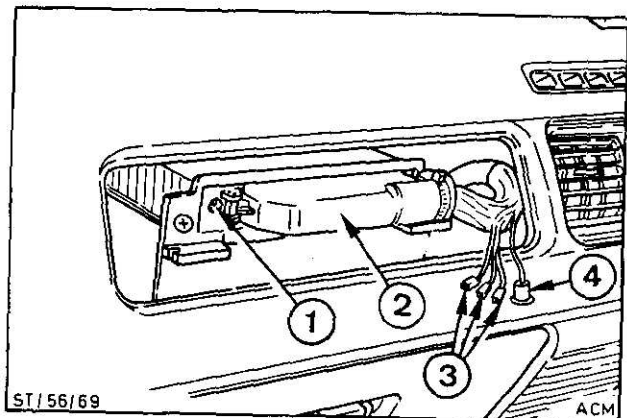

ECU

- 1 = CO adjusting crew
- 2 = Module with multiplug
- 3 = Cable for retarding the spark timing
- 4 = Self test connector

PART A – Engine, Engine Management and Turbocharger

2. Electronic Engine Management

2.3 System Sensors and Actuators (cont'd.)

The system sensors (inputs) are:

The Throttle Position Sensor (TPS)

- This unit is fitted to the throttle shaft and senses the throttle position. At idle speed voltage is 5.0–4.5 volts and at full throttle the voltage drops to 0.5 volt.
- The switch can be adjusted within the limits of its elongated fastening holes. (See "Service Adjustments".)

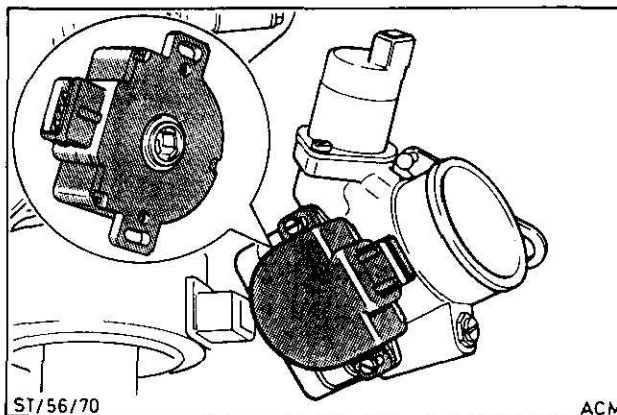

Throttle Position Sensor (TPS)

The Manifold Absolute Pressure (MAP) Sensor

- The MAP-Sensor is fitted to the left fender apron and connected to the air chamber by a hose.
- Depending on the manifold pressure, the Sensor regulates between 0.25 to 4.75 volts. If manifold pressure exceeds 0.9 bar, the sensor signals the ECU to cut-off fuel discharge by the injector valves.
- The sensor cannot be adjusted or repaired.

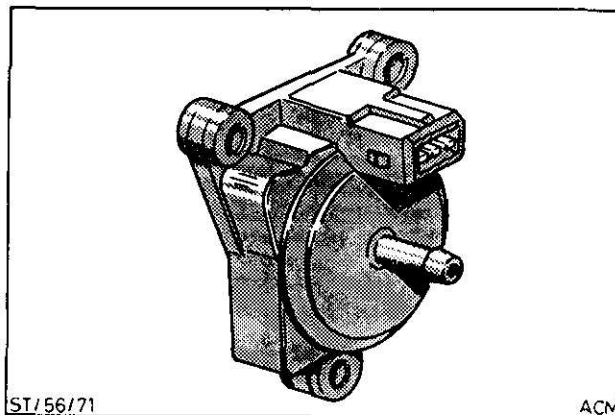

Manifold Absolute Pressure Sensor (MAP)

The Air Charge Temperature (ACT) Sensor

- This sensor is of the NTC resistor type, its resistance decreases as temperatures increase.
- The ACT is screwed into the air chamber and can only be replaced as a unit if defective.
- At 0° C, for example, the resistance is 9.75 kOhm and at 70° C the reading is 0.53 kOhm. Depending on the signal received from the ACT, the ECU module will vary the injection and ignition timing and also affect operation of the Turbocharger. (For further details see section "Turbocharger".)

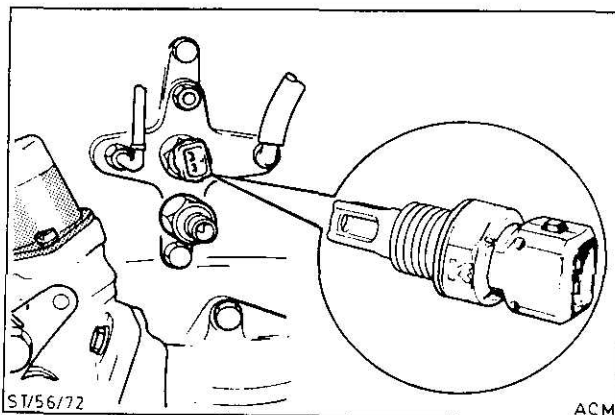

Air Charge Temperature Sensor (ACT)

PART A – Engine, Engine Management and Turbocharger

2. Electronic Engine Management

2.3 System Sensors and Actuators (cont'd.)

Engine Coolant Temperature (ECT) Sensor

- The ECT is also of NTC resistor type and its operating range is identical to that of the ACT.
- The ECT is screwed into the cylinder-head and its signal to the module affects injector open time and idle speed.

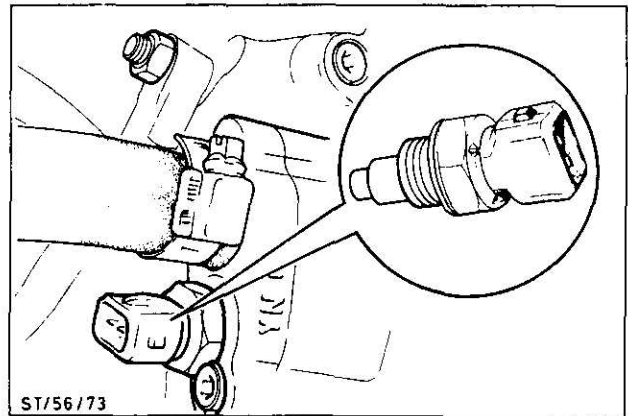

Engine Coolant Temperature Sensor (ECT)

Engine RPM and TDC Sensor

- This sensor is bolted to the engine front end. The crankshaft pulley has 4 identical teeth spaced at precisely 90°. The sensor sends a signal to the module whenever a tooth passes the sensor. From this signal the module determines engine speed (RPM) and the TDC-position of each piston (crankshaft position).

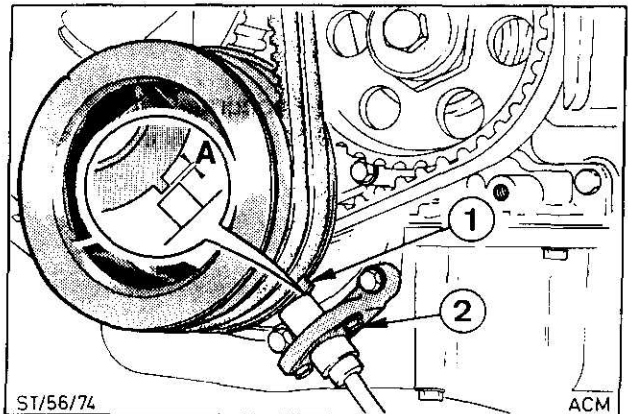

RPM/TDC-Sensor

- The gap between the sensor and the teeth on the crankshaft pulley is 0.4 to 1.0 mm and is factory set (see service adjustments).

1 = Tooth on crankshaft pulley
2 = Sensor
A = 0.4 to 1.0 mm

The Phase Sensor-Distributor

- This sensor is located inside the distributor. It signals (and the signals from the RPM/TDC sensor) enable the ECU to identify the phase of each cylinder following the firing order.
- The gap between the sensor and the teeth of the distributor cam is 0.2 to 0.3 mm and is factory set (see service adjustments).

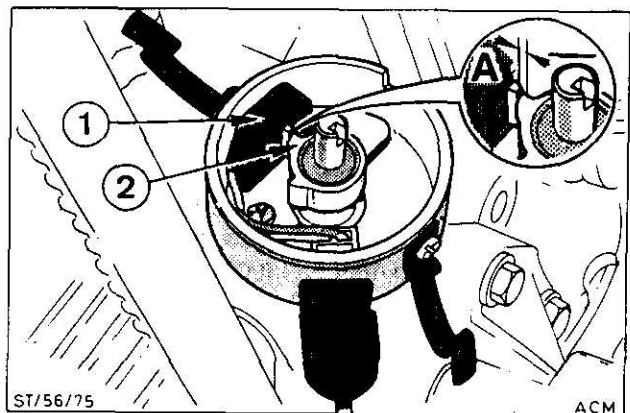

Phase Sensor-Distributor

1 = Sensor
2 = Tooth
A = 0.2 to 0.3 mm

PART A – Engine, Engine Management and Turbocharger

2. Electronic Engine Management

2.3 System Sensors and Actuators (cont'd.)

After comparing sensor signals with its own permanent memory, the ECU sends out signals to a number of actuators (outputs).

These actuators are:

The Fuel Pump

- The fuel pump is switched on and off via a relay when the engine is started or stalled.

The Fuel Injectors

- The ECU provides accurate control of the solenoid operated fuel injectors to discharge fuel.

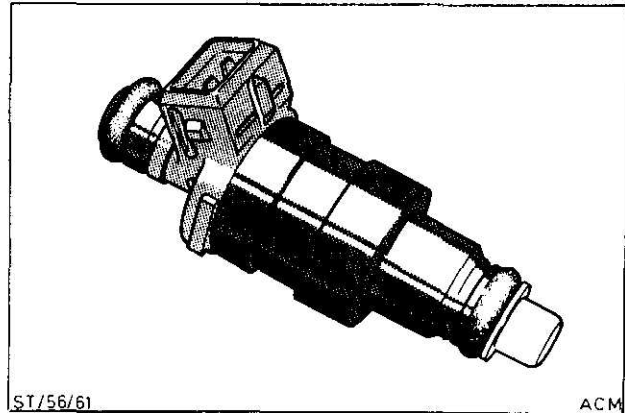

Fuel Injector

The Idle Speed Control (ISC) Valve

- This unit regulates the engine demand for air depending on engine temperature, engine load, or switched on accessories.
- When the throttle plate is in the closed position and engine speed is within the controlled idle speed range, air is allowed to bypass by means of the idle speed control valve. The valve, which is controlled by a variable current from the ECU, adjusts the air flow into the engine in order to maintain a constant idle speed.
- With cold engine, the valve regulates speed above 1200 RPM.
- With hot engine, the valve regulates speed below 1200 RPM only.
- The valve is non-adjustable.

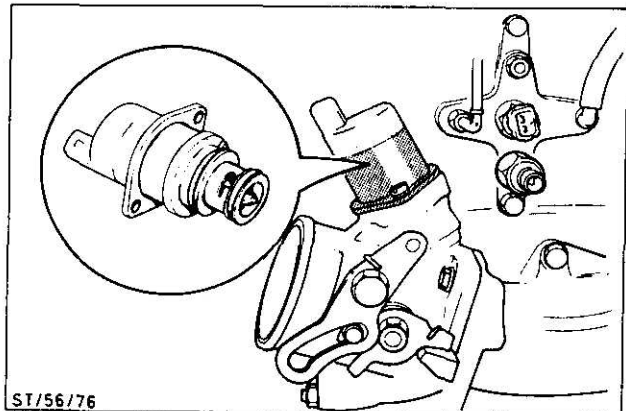

Idle Speed Control (ISC) Valve

PART A – Engine, Engine Management and Turbocharger

2. Electronic Engine Management

2.3 System Sensors and Actuators (cont'd.)

The Boost Pressure Control Valve

- This solenoid valve is directly connected to the high pressure side of the turbocharger by a hose. Depending upon whether the valve is open or closed it will either “vent-off” a portion of the boost to the inlet side of the compressor (valve open) or direct it to the waste gate actuator (valve closed). For further information see section “Turbocharger”.

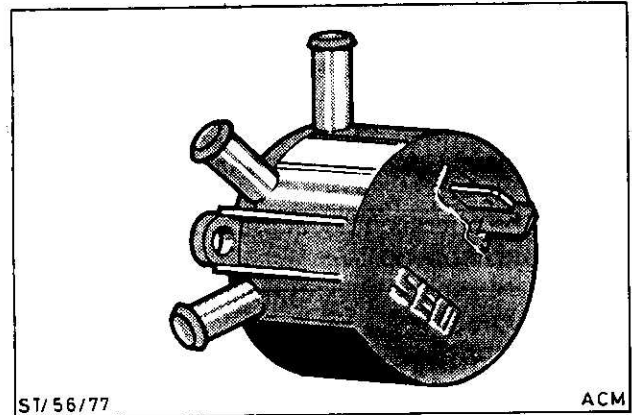

Boost Pressure Control Valve

The Ignition Module

- This module receives a signal from the ECU module to release a spark.

2.4 Further Important Notes on Electronic Engine Management

Limitation on Engine Revolutions

- For information see section “The Turbocharger”.

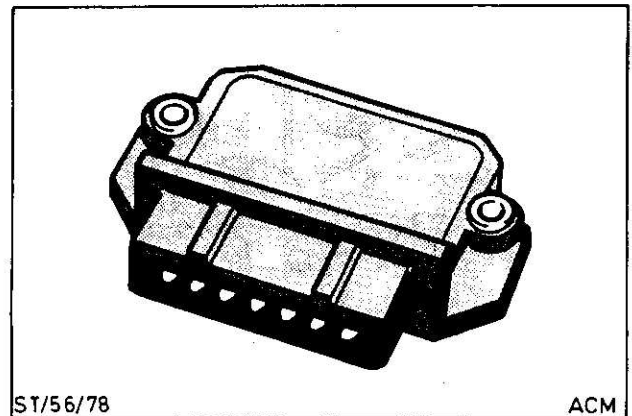

Ignition Module

Warning Light-Engine Management Failure

- This warning light is located next to the auxiliary warning lights.
- When the light switches on, the driver will be informed, that a failure in the engine management system have occurred. For further information see section “Maintenance, Service Adjustments and System Checks”.

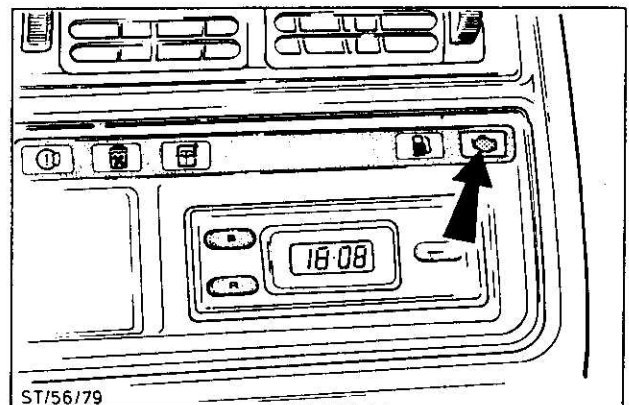

Warning Light – Engine Management failure

PART A – Engine, Engine Management and Turbocharger

3. The Turbocharger

3.1 General Description

The turbocharger (make Garrett, type T3) with integral wastegate and intercooler, used for the Sierra Cosworth engine, is similar to the turbocharger that is fitted to the Escort RS Turbo engine. In addition, the Sierra Cosworth turbocharger is watercooled. The principle of operation of both turbochargers are similar and described in the Escort RS Turbo Workshop Manual.

- The turbocharger is designed to give boost pressure at relatively low engine speeds, thus giving a useful increase of torque under normal driving conditions.
- The operation boost pressure is 0.7 bar. Maximum boost pressure is limited to 0.9 bar above atmospheric.

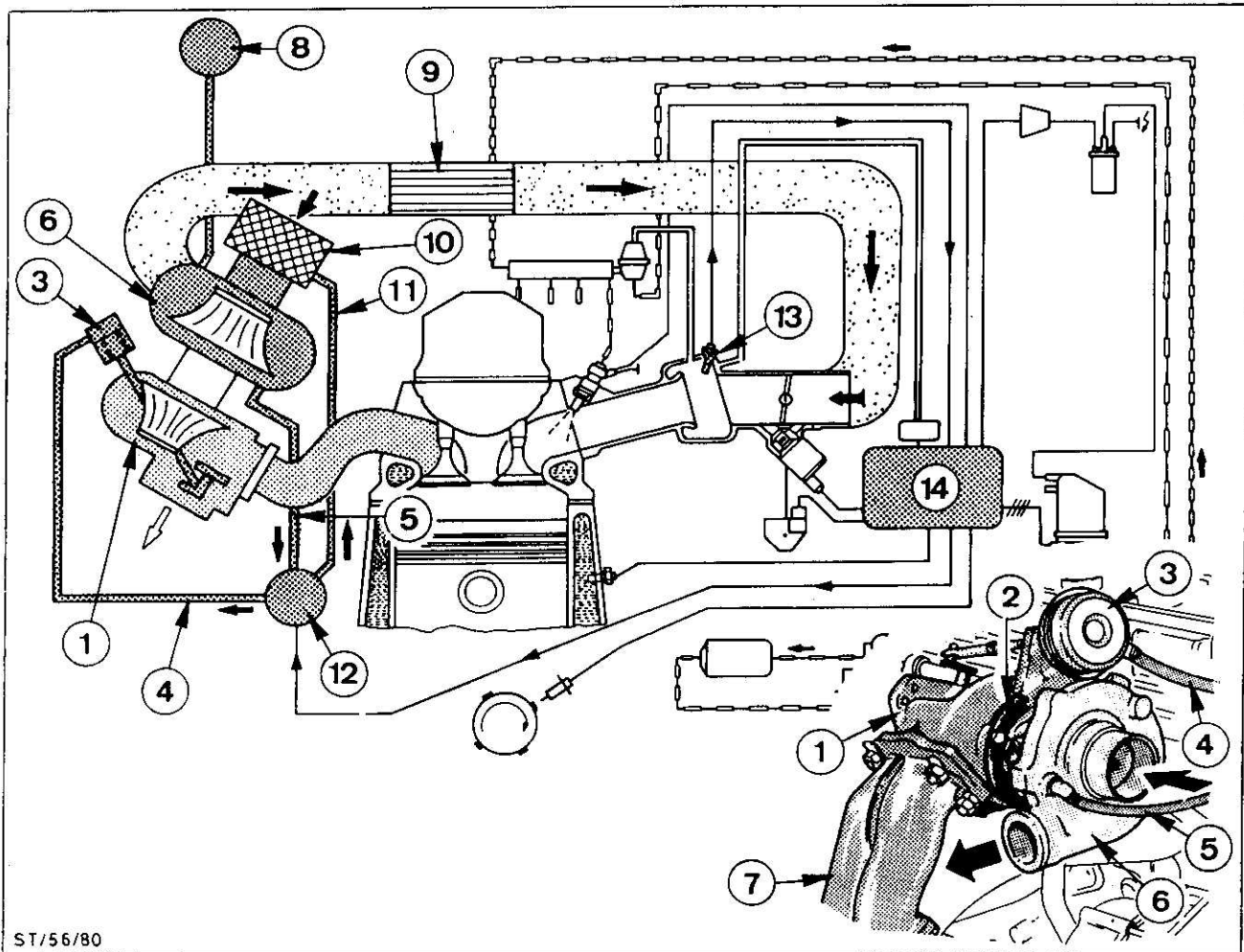

ST/56/80

Turbocharger assembly

- | | |
|---|--|
| 1 = Turbine housing with integral waste gate | 7 = Exhaust manifold assy. |
| 2 = Watercooled intermediate housing | 8 = Boost pressure gauge |
| 3 = Wastegate actuator | 9 = Intercooler |
| 4 = Connection – boost pressure control Valve to Wastegate actuator | 10 = Air cleaner |
| 5 = Connection – Compressor to boost pressure control valve | 11 = Relief connection (vent) |
| 6 = Compressor housing | 12 = Boost pressure control valve |
| | 13 = Air Charge Temperature (ACT) Sensor |
| | 14 = ECU |

PART A – Engine, Engine Management and Turbocharger

3. The Turbocharger

3.1 General Description (cont'd.)

- The lubricating oil for the turbocharger is taken from the main oil pressure system of the engine (the oil feed pipe is connected to the oil pressure switch). The return oil flows back to the sump through a pipe of relatively large cross-section.
- The watercooled intermediate housing of the turbocharger prevents overheating of the turbine shaft bearings and the turbocharger housing. After switch-off the coolant will prevent excessive temperature build-up of the unit.

The coolant feed pipe for the turbocharger intermediate housing is connected to the thermostat housing. The return coolant flows back to the expansion tank.

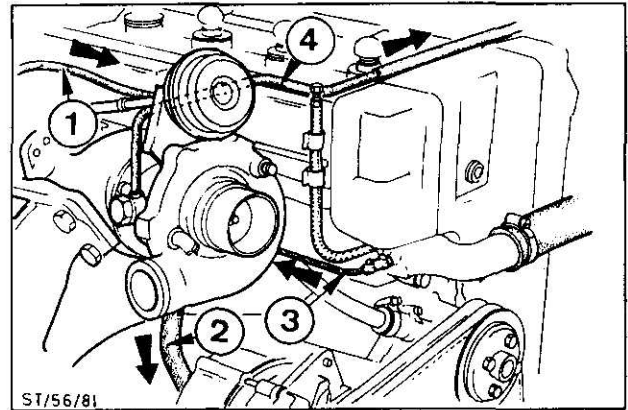

Pipe connections

- 1 = Oil feed pipe
- 2 = Oil return pipe
- 3 = Coolant feed pipe
- 4 = Coolant return pipe

- The integral wastegate regulates the flow of exhaust gases. Due to the engine's demand for boost the exhaust gases are either allowed to the exhaust turbine or through the bypass duct into the vehicle exhaust system circumventing the exhaust turbine.

The wastegate actuator, which is connected to the wastegate by a rod, is controlled by the ECU via a boost pressure control valve.

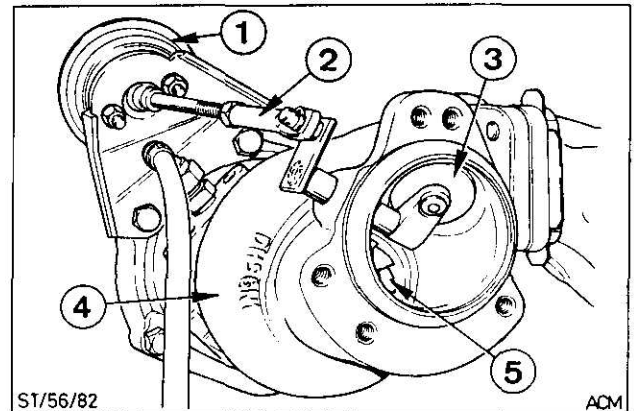

- 1 = Wastegate actuator
- 2 = Actuator rod
- 3 = Wastegate
- 4 = Turbine housing
- 5 = Turbine impeller

- An intercooler (air to air radiator) is fitted to cool the charge air.
- The turbocharger is maintenance-free.

PART A – Engine, Engine Management and Turbocharger

3. The Turbocharger

3.2 Boost Pressure Control

The Sierra RS Cosworth is equipped with electronic/mechanical boost pressure control.

The ECU is programmed to control boost via a solenoid operated control valve on receipt of sensor signals.

- The boost pressure control valve is directly connected to the high pressure side of the turbocharger by a hose.

Depending upon whether the valve is open or closed it will either “vent off” a portion of the boost to the inlet side of the compressor (aircleaner) or direct it to the wastegate actuator.

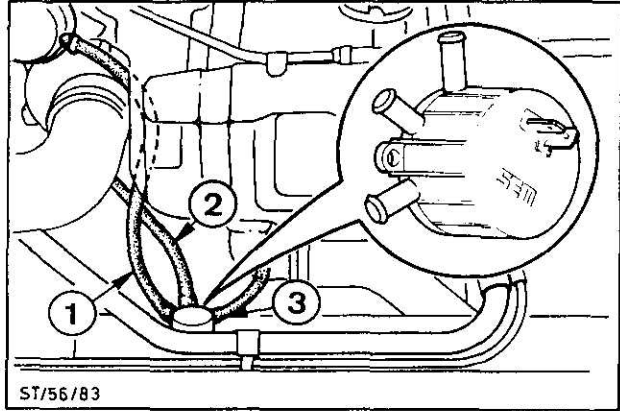

Boost pressure control valve in situ

- 1 = Hose - Wastegate Actuator
- 2 = Hose - Turbocharger high pressure side
- 3 = Hose to aircleaner (“vent off”)

- 1 = Exhaust turbine
- 2 = Compressor impeller
- 3 = Wastegate actuator
- 4 = Boost pressure control valve
- 5 = Air charge temperature (ACT) sensor
- W = Wastegate connection
- C = Compressor connection
- R = Relief connection (vent)
- M = ECU

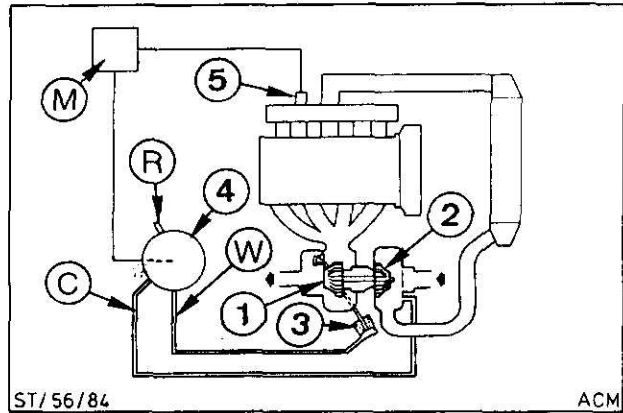

Boost pressure control valve

- With engine in operation, the boost pressure control valve is open, allowing air charge to “vent off”, depending on receipt of signals from the ECU.

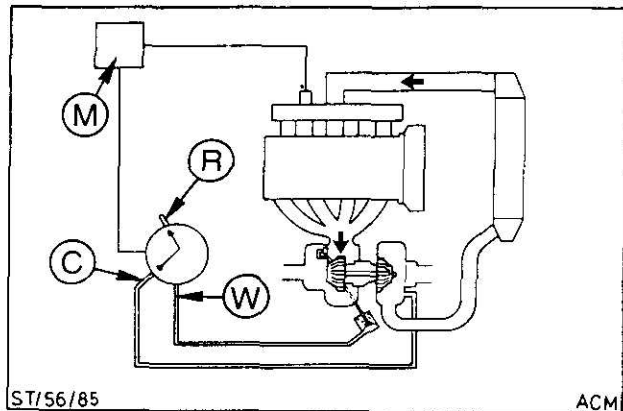

Boost pressure control valve open, allowing air charge to “vent off”. The wastegate is closed.

PART A – Engine, Engine Management and Turbocharger

3. The Turbocharger

3.2 Boost Pressure Control (cont'd.)

- The boost pressure control valve will be closed gradually when the engine speed is above 6000 RPM or when the air charge temperature exceeds 70° C.
- When these signals from the RPM/TDC-sensor and the Air Charge Temperature (ACT) sensor are received by the ECU, it closes the solenoid control valve gradually applying full turbo pressure to the wastegate actuator which then fully opens the wastegate. A high amount of the exhaust gases are allowed through the bypass duct into the vehicle exhaust system circumventing the exhaust turbine. The boost pressure is reduced to approximately 0.3 bar.

The reduction in boost pressure will reduce the temperature to acceptable working level.

The By-pass Valve

A special by-pass valve (located next to the intercooler) is directly connected to the air chamber, the intercooler and the inlet trunking by hoses. The by-pass valve prevents a pressure build up of air charge in front of the throttle plate when the throttle plate is suddenly closed. With the throttle plate in closed position, the vacuum in the air chamber opens the by-pass valve and an amount of charged air will be by-passed from the intercooler back to the inlet trunking.

Limitation on Engine Revolutions

- In case the boost pressure exceeds 0.9 bar, the fuel injection at the injector valves will be interrupted.
- At 6500 to 6800 engine RPM, the boost pressure is reduced to approximately 0.3 bar by the boost pressure control valve.
- At 6800 to 7000 engine RPM, the ECU is programmed in such a way to interrupt every second injection (the engine will remain in performance but without increase of engine RPM).
- At speeds above 7000 RPM, injection will cut off totally, controlled by the ECU.

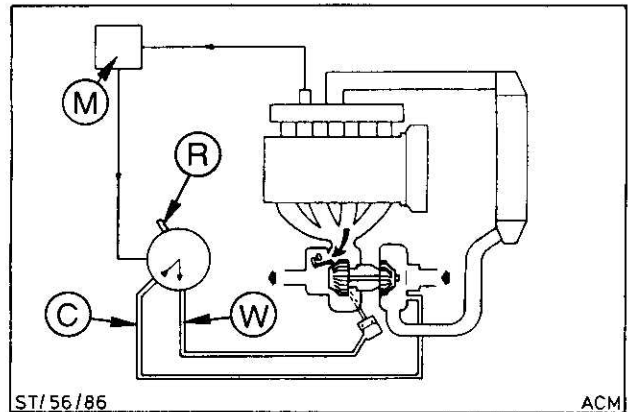

Boost pressure control valve closed allowing air charge to open the wastegate via the actuator

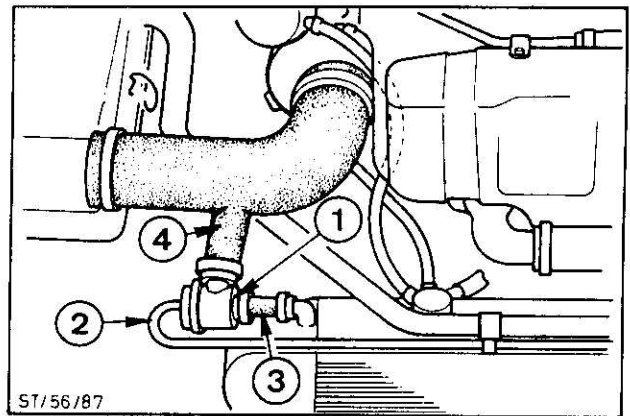

By-pass Valve

- 1 = Valve
- 2 = Connection to air chamber
- 3 = Connection to intercooler
- 4 = Connection to inlet trunking

PART A – Engine, Engine Management and Turbocharger

4. Maintenance, Service Adjustments and System Checks

4.1 Maintenance

The routine service schedule for the Sierra RS Cosworth is similar to the Sierra with the standard OHC-engine:

- First free Service at 1500 km
- Interim Service at 10.000 km and
- Standard Service at 20.000 km.

There are some exceptions which are included in the Sierra Service Voucher Booklet.

- The timing belt must be replaced at 80.000 km.

4.2 Service Adjustments

Throttle Plate Setting Screw

- This screw is factory set and sealed and **must not be altered in service.**

Basic Idle Speed Control Screw

If the engine idle speed is not to specifications at the first servicing (1500 km), it can be adjusted by means of the basic idle speed control screw.

- Disconnect multiplug from idle speed control valve, untighten locknut and adjust idle speed screw to achieve correct idle rpm with warm engine.

Idle speed: 850 rpm.

Note: After refitting the multiplug, the engine will raise to high engine rpm for a short period of time.

Throttle Position Sensor (TPS)-Adjust

After disassembling and re-assembling the switch can be adjusted within the limits of its elongated fastening holes.

- Loosen fastening screws so that the housing snaps back by spring pressure to the original factory set throttle plate adjustment.

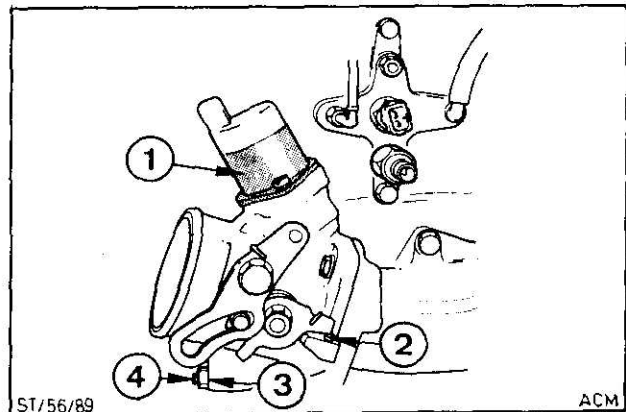

- 1 = Idle speed control valve (ISC)
- 2 = Throttle plate setting screw
- 3 = Lock nut
- 4 = Basic idle speed control screw

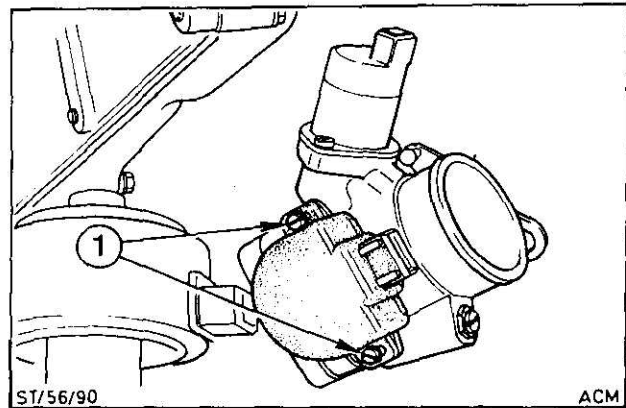

Throttle position sensor

- 1 = Fastening screws

PART A – Engine, Engine Management and Turbocharger

4. Maintenance, Service Adjustments and System Checks

4.2 Service Adjustments (cont'd.)

Adjustment of Idle Mixture

Specified mixture CO at idle: 1–1.5% CO

- The CO adjuster screw is located on the left hand side of the module multi plug.
- Using a suitable tool carefully remove the tamper-proof plug thereby making sure that the tool does not penetrate the plug by more than 3 mm. Excessive penetration may cause damage to the potentiometer located behind the adjuster screw.
- To adjust CO the adjuster screw can be turned from stop to stop. After correct adjustment the screw should be protected with a tamper proof plug.

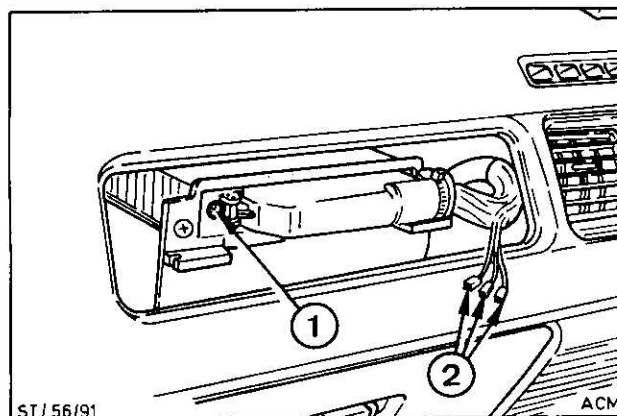

- 1 = Mixture control screw
2 = Cable for octane adjust

Ignition Timing

The ignition timing (16 BTDC) **cannot** be adjusted in Service. The ignition timing is controlled by the ECU module and depends on engine temperature, load and manifold absolute pressure.

When replacing the distributor, the distributor must be inserted with the rotor aligning correctly with the TDC marking for cylinder No. 1 on the housing. A deviation of up to 4° will be compensated by the ECU module.

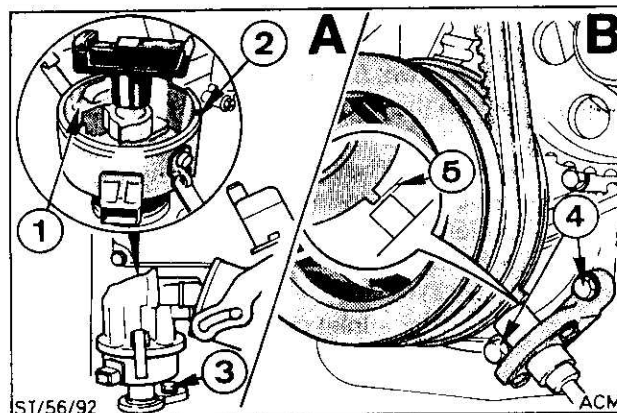

A = Distributor

- 1 = Phase-sensor
2 = TDC marking – cyl. No. 1
3 = Fastening bolt

B = RPM/TDC-Sensor

- 4 = Fastening bolt
5 = 0.4–1.0 mm

Retarding the Ignition Timing

To meet fuels with lower octane rating the ignition timing can be retarded electronically by 2, 4 or 6° by connecting the cable connectors (near the RH side of the ECU module) in various ways.

Connections

- Green plug to white plug = ignition retarded by 2°
- Blue plug to white plug = ignition retarded by 4°
- Green and blue plug to white plug = ignition retarded by 6°

(The white plug connects to chassis earth).

Adjusting the RPM/TDC Sensor

The air gap between the sensor and the cam should be 0.4 to 1.0 mm.

- To adjust the air gap, the fastening bolt for the sensor must be untightened to enable resetting of the sensor.

PART A – Engine, Engine Management and Turbocharger

4. Maintenance, Service Adjustments and System Checks

4.3 System Checks

Quick Test

- The ECU module includes an internal selftest facility.
- A warning light on the instrument panel will switch on if there is a defect in one of the sensor circuits.
- Simultaneously a coded signal is fed to the test connector near the RH side of the ECU module.
- Connecting an LED tester to this test plug allows a quick test to be carried out on the following sensor circuits:
 - RPM/TDC sensor
 - Sensor – cylinder phase (distributor)
 - Sensor – inlet air temperature (ACT)
 - Sensor – engine coolant temperature (ECT)
 - Sensor – inlet manifold absolute pressure (MAP)
- The LED tester for the EEC IV-system (Loewener tool No. 013 20 60 or Churchill tool No. 047 20 60) may be used.
- The quick test is carried out with the engine not running but with the ignition switched on.
- During the quick test the ECU module transmits codes in the form of electrical pulses.

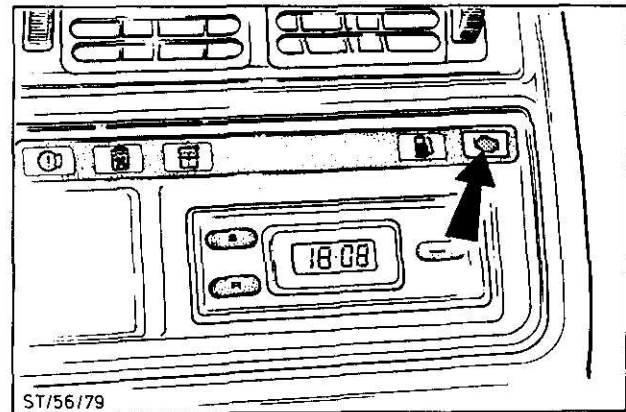

Warning Light – Engine Management failure

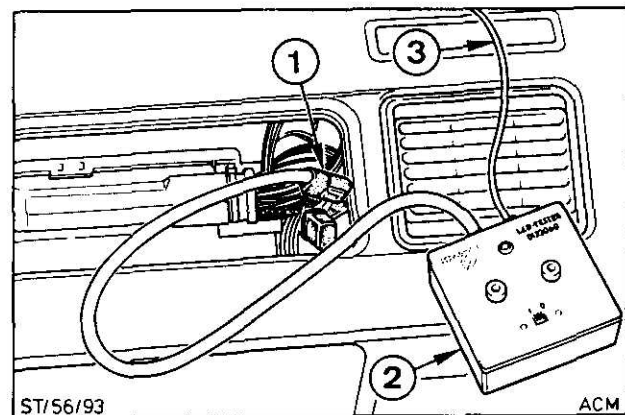

Quick Test

- 1 = Test connector
- 2 = LED Tester
- 3 = Cable – battery plus

PART A – Engine, Engine Management and Turbocharger

4. Maintenance, Service Adjustments and System Checks

4.3 System Checks (cont'd.)

Quick Test (cont'd.)

- The coded signals are displayed as follows:
 - Start of test: Indicated by a series of short on – off pulses.
 - Pause
 - Codes: These are indicated by a series of on – off pulses each of them having a duration of one second. Each code is made up of two figures seperated by a pause. These two figures identify a defect in a sensor circuit.
 - End of test: Indicated by a series of short on – off pulses.

- During the quick test more than one defect code may be displayed.

- The quick test repeats itself until the ignition is switched off.

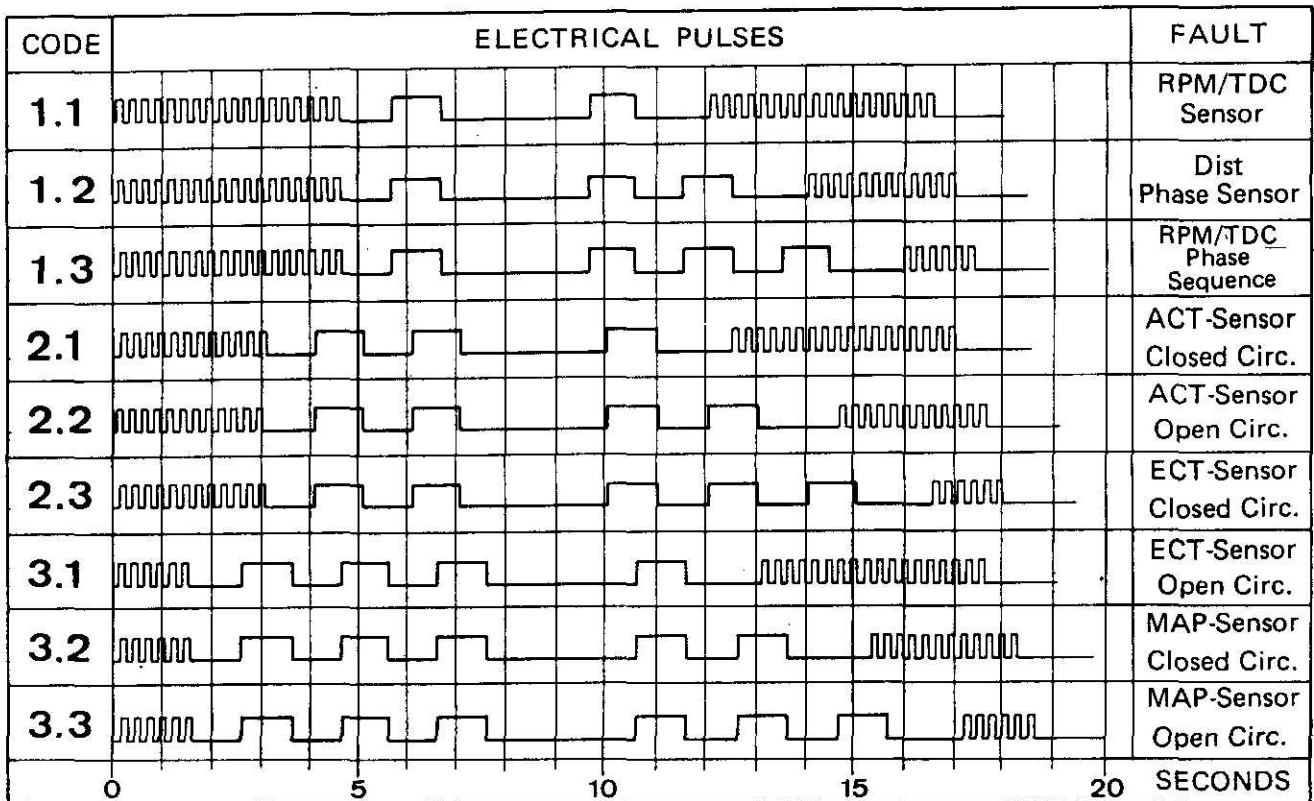

Test codes

PART A – Engine, Engine Management and Turbocharger

4. Maintenance, Service Adjustments and System Checks

4.3 System Checks (cont'd.)

Basic Checks

- A detailed Diagnosis can be performed using the diagnostic guide contained in the Sierra RS Cosworth Workshop Manual.
- The following test equipment is required:
 - FE 60 Breakout Box
 - Multimeter (Siemens, AVO or Keithly)
 - Test lead No. 2 (33-002)
 - New test lead No. 7 (29-005)
- The Test lead No. 2 allows an overall check to be performed on the engine management system like the resistance of the sensors and electronic actuators, the wiring loom and the plug connections.
- The new test lead No. 7 has to be connected to the ECU module, the multi-plug for the module and Test lead No. 2.

Connected in this way, the complete system can be tested i.e. the ECU module itself, and the voltages and current supplies for the various sensors and other electronic components.

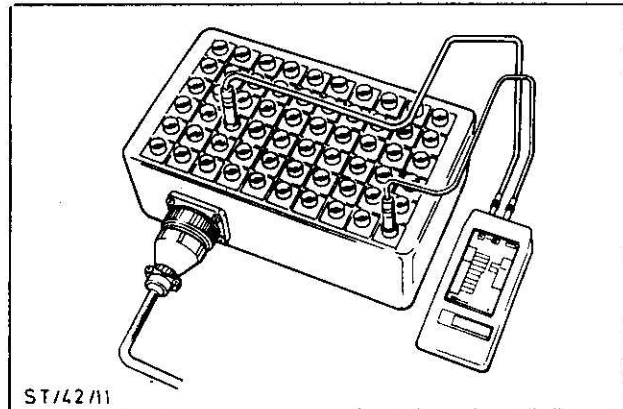

FE 60 Breakout Box with Multimeter and Test lead No. 2

Fuel System

For pressure- and leak tests on the fuel system the available pressure tester 23-011 A/B should be used. Using suitable adaptors the pressure tester can be connected between the fuel rail and the pressure regulator. More detailed information is contained in the Sierra RS Cosworth Workshop Manual.

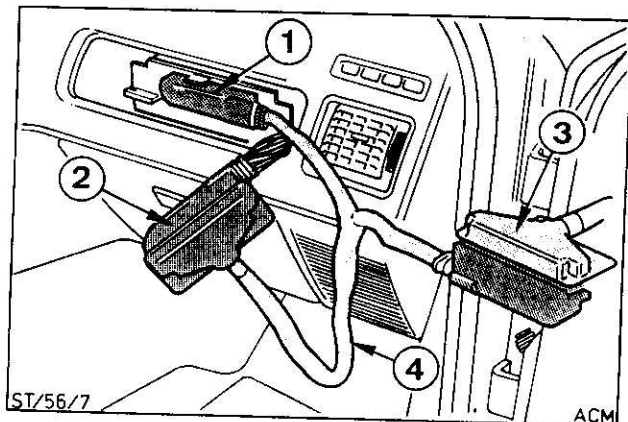

Test lead No. 7

- 1 = Connection to ECU
- 2 = Connection to multiplug of ECU
- 3 = Connection to Test lead No. 2
- 4 = Test lead No. 7

Turbocharger

Detailed instruction for checking and adjusting the boost pressure are included in the Sierra RS Cosworth Workshop Manual.

PART A – Engine, Engine Management and Turbocharger

5. Technical Data – Part A

Engine – General

Engine Code	N5A
Bore	90.82 mm
Stroke	77.00 mm
Cubic capacity	1995 cm ³ effective
Poweroutput	150 kW (DIN)
	at 6000 rpm
Torque	278 Nm (DIN)
	at 4500 rpm
Firing order	1 – 3 – 4 – 2
Compression ratio	8.0 : 1
Idle speed	850 rpm
Maximum engine speed	
– continued running	6500 rpm
– intermittent running	6800 rpm
Operation boost pressure	7.0 bars
Maximum boost pressure limited to	9.0 bars
Spark plugs	AGPR 901 C
Ignition timing	16° BTDC at idle
(cannot be adjusted in service)	

Engine Lubrication

Oil specification	API/SF-CC
Oil change intervall	10.000 km
Oil change capacity	3.0 litres without filter
	3.4 litres including oil filter
Minimum oil pressure	1.8 bars at 850 rpm
(with SAE 20 W-50 oil at 80° C)	2.4 bars at 2000 rpm

Tightening Torques – Cylinder Head

	Nm	Note
Cylinder head bolts – Stage 1	30–35	
– Stage 2	65–70	
– Stage 3	Rotate extra 80°–90°	
Camshaft bearing caps – 6 mm	8–10	
– 8 mm	19–23	
Valve cover to cylinder head	8–10	
Camshaft sprocket gear-fastening bolt	59–63	
Thermostat housing to cylinder head	18,5–21,5	
Inlet manifold to cylinder head	18,5–21,5	
Exhaust manifold to cylinder head	19–23	
Spark plug	28–33	
Plenum chamber to inlet manifold	8–10	
Elbow to plenum chamber	18,5–21,5	
Throttle body to elbow	8–10	
Air temperature sensor to plenum chamber	23–25	Loctite 242
Turbocharger to exhaust manifold	40–48	
Oil feed pipe adaptor to turbocharger	25–35	Loctite 242
Turbocharger oil feed pipe to adaptor	25	
Oil return pipe to turbocharger	18,5–21,5	
Coolant feed- and return pipes to turbocharger	19–23	

For detailed Technical Data and Tightening Torques see Sierra RS Cosworth Workshop Manual.

PART B – Transmission and Rear Axle

1. Transmission

1.1 General Description

- The transmission fitted to the Sierra RS Turbo is a five speed manual transmission with close ratios and with fifth gear as overdrive.
- The complete transmission housing is made from aluminium.
- First through fourth and reverse gears mesh within the transmission housing. The fifth speed gears and synchroniser are located on the back of the housing in the extension housing.
- The first-second and third-fourth shift forks are mounted in the shift cover. The shift cover with shift forks and the shift rail, which extends from the extension housing turret to the shift cover, are an assembly.

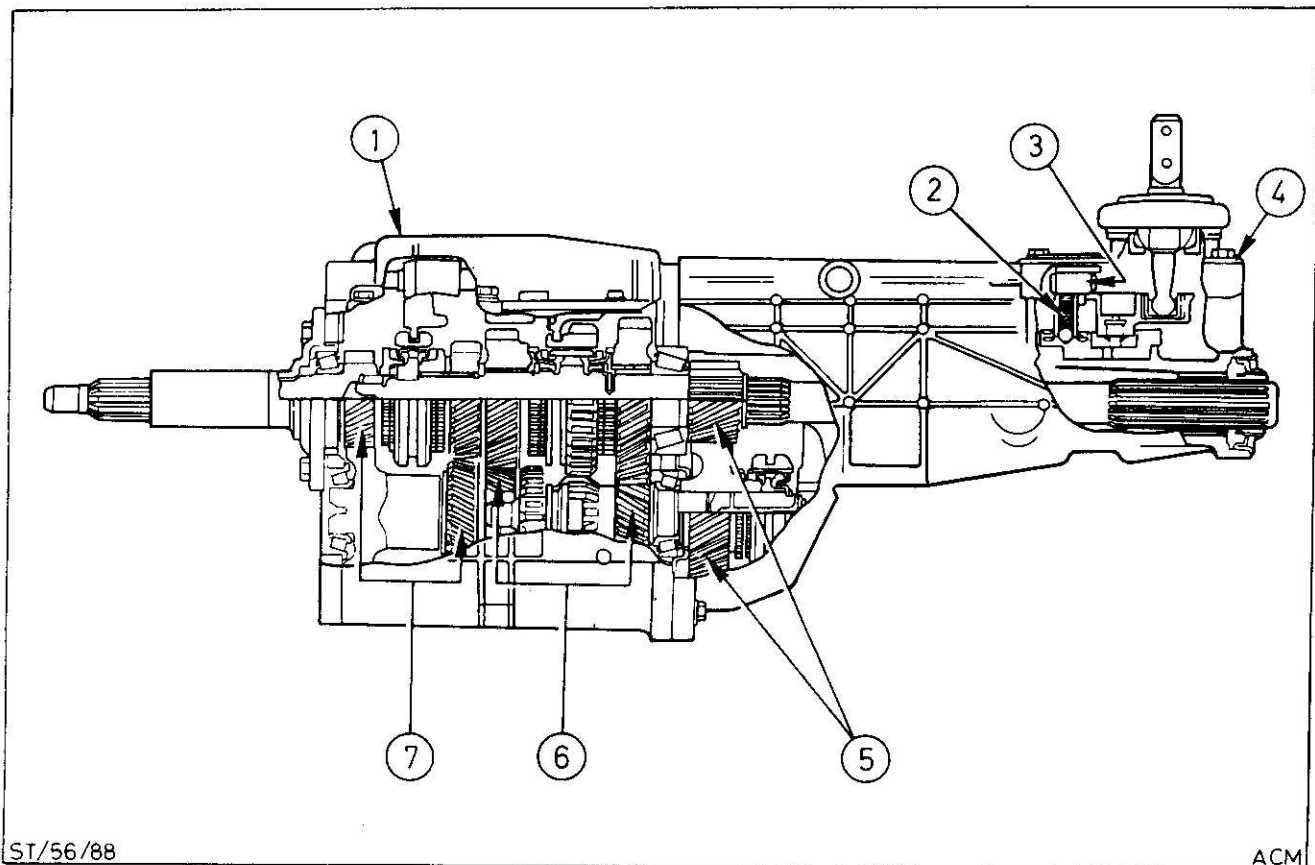

1 = Shift cover with 1st/2nd and 3rd/4th shift forks and shift rail

2 = Shift detent

3 = Shift rail

4 = Turret cover

5 = Fifth speed gears and synchroniser

6 = 1st/2nd speed gears and synchronisers (reverse gear)

7 = 3rd/4th speed gears and synchronisers

PART B – Transmission and Rear Axle

1. Transmission

1.1 General Description (cont'd.)

- The fifth speed synchroniser and reverse idler gear are shifted by an intermediate lever mounted on a pivot pin in the transmission housing.
- The shift detent is located in the extension housing turret.

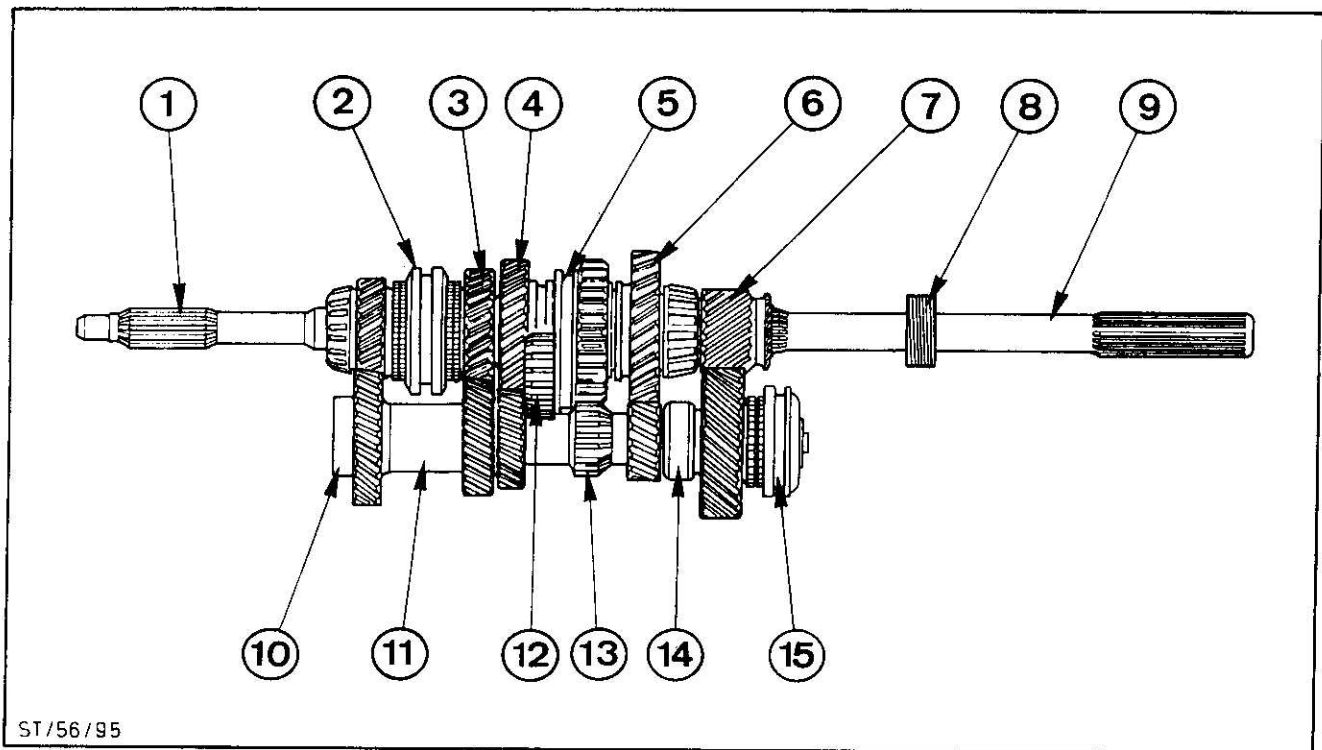

- | | |
|--|-------------------------------|
| 1 = Input shaft | 9 = Output shaft (main shaft) |
| 2 = 3rd/4th synchroniser | 10 = Bearing assembly |
| 3 = Third gear unit | 11 = Countershaft |
| 4 = Second gear unit | 12 = Reverse idler gear |
| 5 = 1st/2nd synchroniser (reverse driven gear) | 13 = Reverse gear |
| 6 = First gear unit | 14 = Bearing assembly |
| 7 = Fifth gear unit | 15 = Fifth gear synchroniser |
| 8 = Speedometer gear | |

PART B – Transmission and Rear Axle

1. Transmission

1.2 Power flow

First Gear

Ratio: 2.96 : 1

1 = 1st/2nd synchroniser

2 = First gear unit

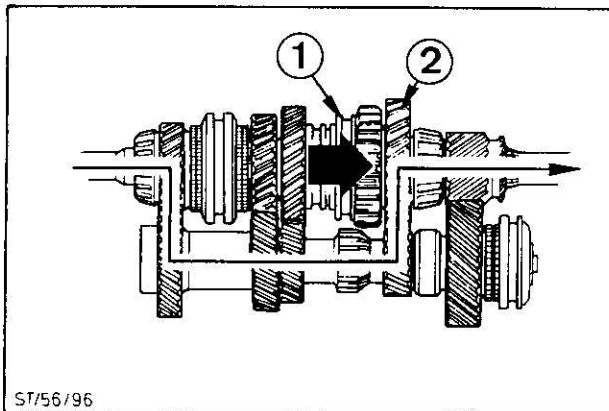

Second Gear

Ratio: 1.94 : 1

1 = 1st/2nd synchroniser

2 = Second gear unit

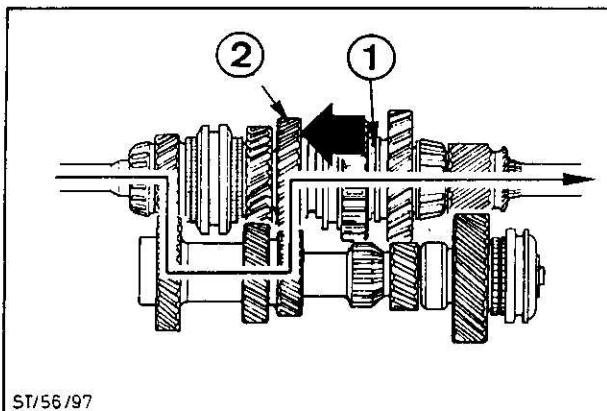

Third Gear

Ratio: 1.34 : 1

1 = 3rd/4th synchroniser

2 = Third gear unit

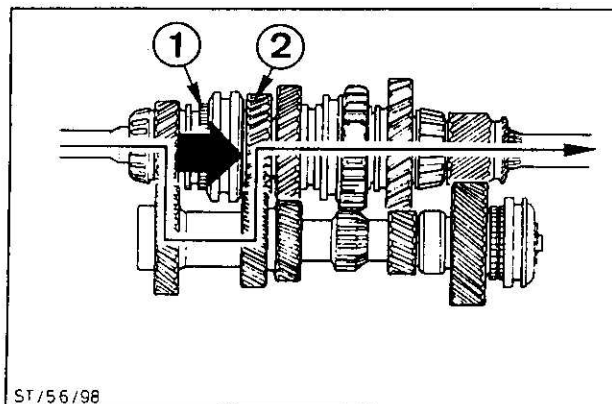

PART B – Transmission and Rear Axle

1. Transmission

1.2 Power flow (cont'd.)

Fourth Gear

Ratio: 1:1

1 = 3rd/4th synchroniser

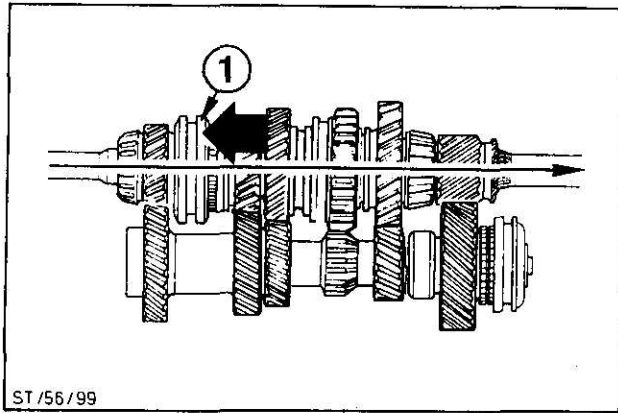

ST/56/99

Fifth Gear

Ratio: 0.8:1

1 = Fifth gear synchroniser

2 = Fifth gear unit

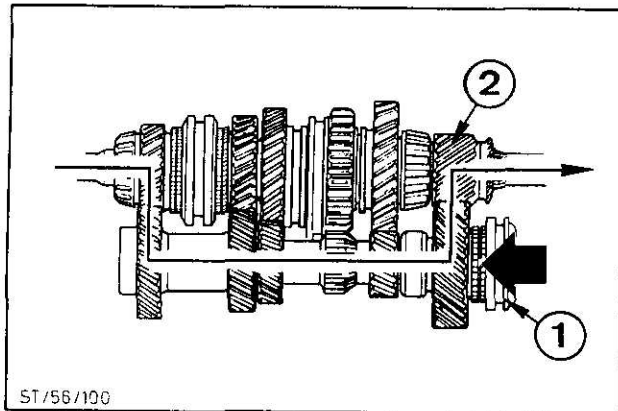

ST/56/100

Reverse Gear

Ratio: 2.76:1

1 = Reverse idler gear

2 = Reverse gear unit

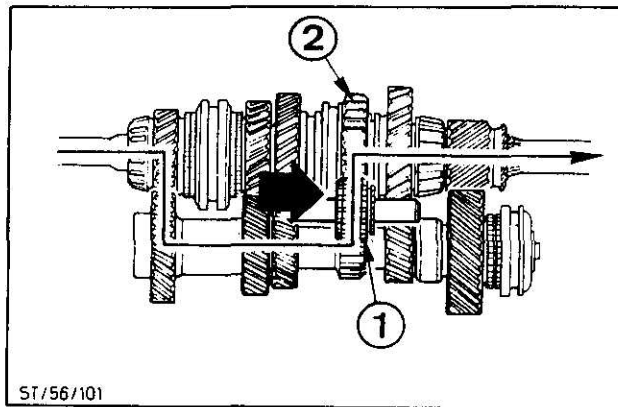

ST/56/101

PART B – Transmission and Rear Axle

1. Transmission

1.3 Important Notes on Disassembly and Assembly

Transmission disassembly and assembly operations are explained in detail in the Sierra RS Cosworth Workshop Manual. This part of the brochure covers some important points only.

- No new special tools are required.
- The transmission has to be mounted in a repair stand using a dealer manufactured adaptor bracket.
- The extension housing and the selector crank of the shift detend should be removed from the transmission housing as an assembly.
The selector crank can not be removed with the extension housing in position, because this is prevented by a lug, located on the bottom of the selector crank which meshes with the detend plate.

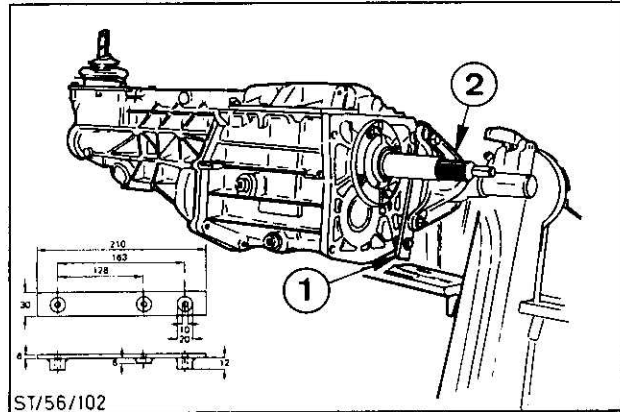

Transmission on stand

- 1 = Adaptor bracket (dimensions in mm)
- 2 = Mounting bracket 16-009

- The shift cover, the 1st/2nd and 3rd/4th shift forks and the shift rail have to be removed from the housing as an assembly.

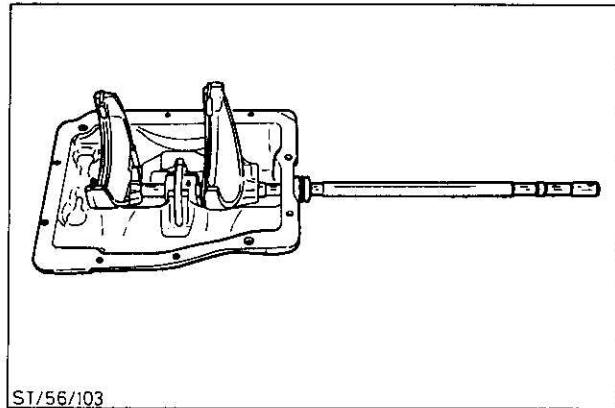

ST/56/103

Shift cover

- The 5th gear, 5th gear synchroniser and shift fork have to be removed from the countershaft as an assembly.

- 1 = Snap ring
- 2 = Spacer
- 3 = Shift fork
- 4 = Roll pin
- 5 = Synchroniser
- 6 = 5th gear
- 7 = Countershaft retainer

Note: Selective washers are located between the countershaft retainer and the rear countershaft bearing race to adjust the end float of the countershaft to specification.

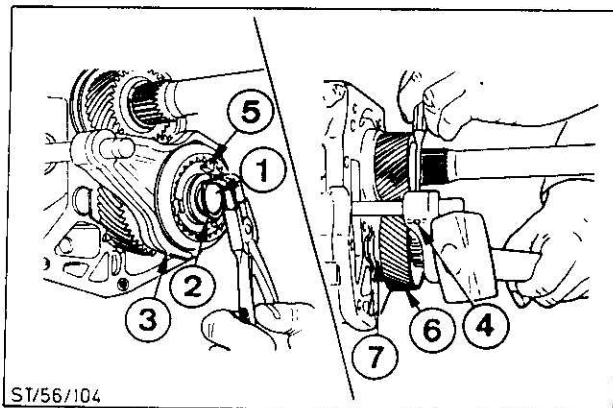

ST/56/104

PART B – Transmission and Rear Axle

1. Transmission

1.3 Important Notes on Disassembly and Assembly (cont'd.)

- After removing the snap ring the fifth gear can be pulled off from the main shaft using a proprietary puller.

Note: The 5th gear cannot be reused.

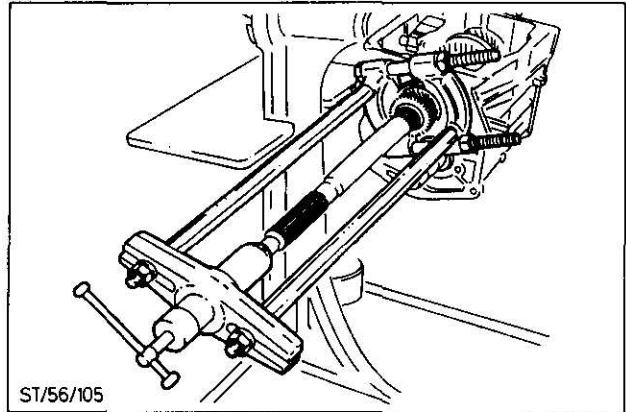

Remove 5th gear from main shaft

- The transmission shafts have to be removed in the following order
 - Input shaft
 - Main shaft
 - Countershaft
- To remove the input shaft, the flat section of the synchroniser tooth ring must first be positioned above the countershaft gear.
- To remove the main shaft, first remove the rear bearing cup. To do this pull the main shaft to the rear until the first gear stops against the transmission housing. Removal of the main shaft is from the top of the housing.

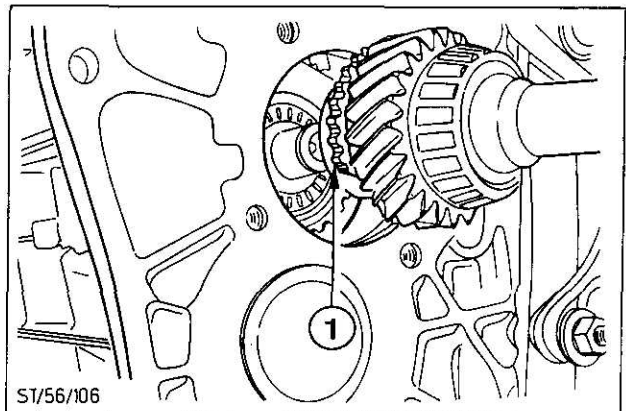

Remove the input shaft

1 = Flat section of tooth ring

- Before removing the taper roller bearing from the countershaft, remove the oil collector for the fifth gear from the end of the shaft.
- To remove the countershaft, pull out the rear bearing cup and then pull off the taper roller bearing using a suitable puller. The countershaft can then be removed from above.

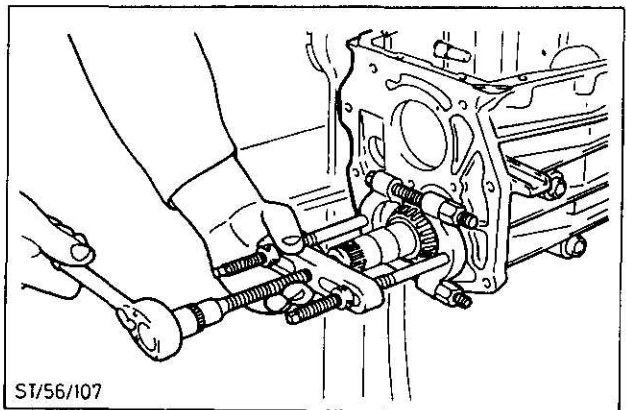

Remove bearing from countershaft

PART B – Transmission and Rear Axle

1. Transmission

1.3 Important Notes on Disassembly and Assembly (cont'd.)

- Using special tool 21-028 pull off the input shaft bearing.

Press new bearing onto shaft and bearing cup into housing.

- With the countershaft in situ, install rear bearing using a press and a suitable piece of tubing.

Note: Support countershaft using two suitable steel bars (thickness 6–8 mm) to prevent damage to the transmission housing.

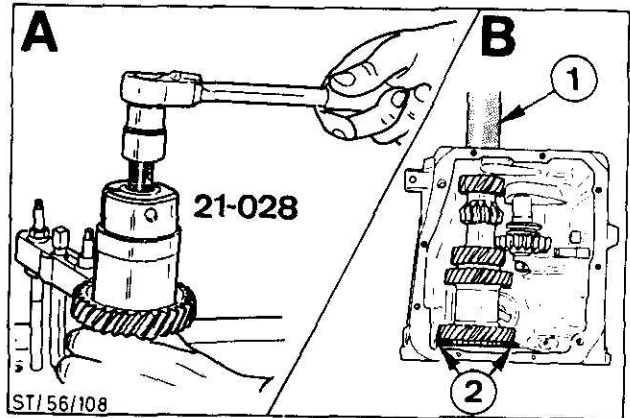

A = Removal of the front bearing from the countershaft

B = Installing the rear bearing

1 = Tubing

2 = Steel bars

- End play of the countershaft is adjusted by shims between the bearing outer ring and the bearing retainer.

Specified end float 0.025 – 0.127 mm

Measure end float using a thin shim. If necessary remove bearing retainer and add shims as required. (Shim sizes – see Technical Data).

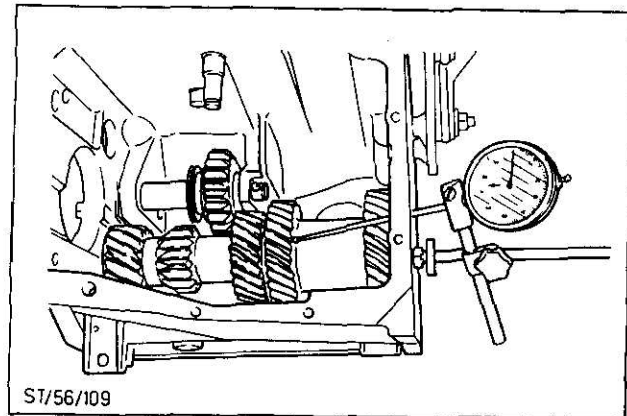

Measuring countershaft end float

- Install main shaft
- End play of the main shaft is controlled by shims between the bearing outer ring and the retainer of the input shaft bearing.

This end play is measured after the transmission has been completely assembled.

For this reason, no shims should be fitted when installing the input shaft and the bearing retainer.

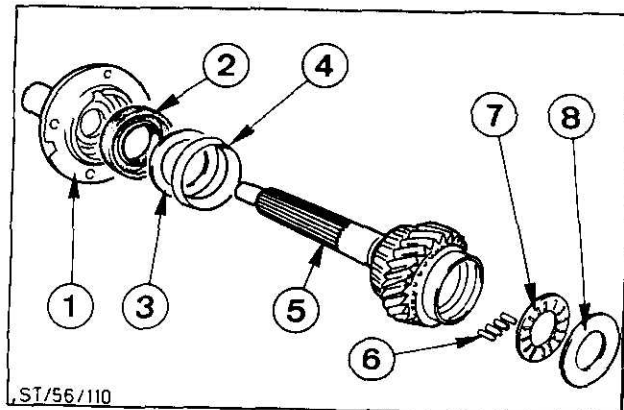

1 = Bearing retainer

2 = Oil seal

3 = Shim

4 = Bearing outer ring

5 = Input shaft

6 = 15 needle rollers

7 = Thrust bearing

8 = Bearing race

PART B – Transmission and Rear Axle

1. Transmission

1.3 Important Notes on Disassembly and Assembly (cont'd.)

- To fit the 5th gear to the main shaft, the gear should be heated up to approx. 600° C using a hot air blower.
- When disassembling the gear shift cover make sure to mark the shift forks and to set the shift segments and the shift lever in neutral position.

Further detailed instructions on "dismantling and assembling of the gear shift cover" are contained in the Sierra RS Cosworth Workshop Manual.

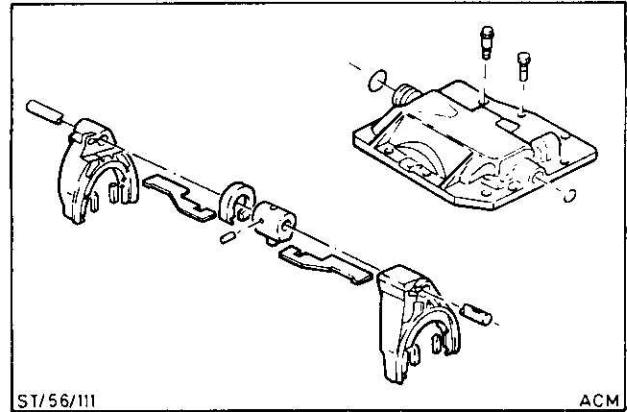

Gear shift cover – disassembled

- Before fitting the transmission extension, the cranked selector lever with detend ball and spring have to be fitted.

- 1 = Roll pin
- 2 = Cranked selector lever
- 3 = Detend spring
- 4 = Detend ball
- 5 = In neutral position install detend ball into detend plate.

Secure cranked selector lever by the roll pin after fitting the transmission extension.

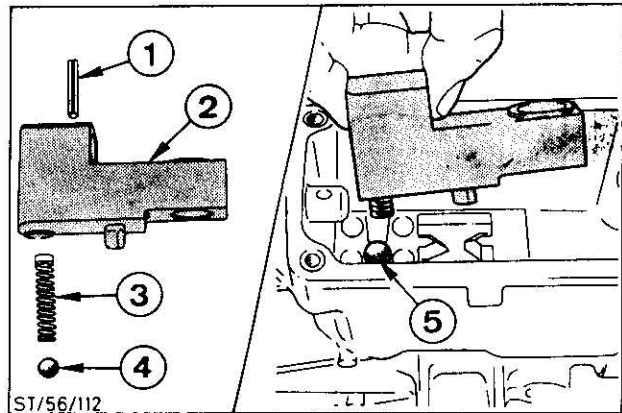

Install cranked shift rod

- Before fitting the gear shift cover, measure end play of the main shaft as follows

- Install dial indicator gauge (see illustration), turn the input shaft and watch deflection of pointer on gauge. Set gauge to zero.
- Using a suitable piece of wood force input shaft upwards and note dial gauge reading.
- Dial reading = shim pack required
Specified end float: $0 \pm 0,5$ mm
- Fit required shim pack between bearing outer ring and input shaft bearing retainer. (For selection of shims see Technical Data).

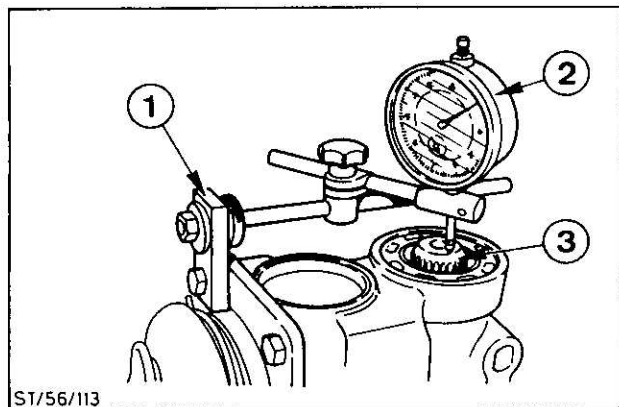

Check end float of the main shaft

- 1 = Bracket – Indicator gauge
- 2 = Indicator gauge
- 3 = Main shaft

PART B – Transmission and Rear Axle

2. Rear Axle and Suspension

- The Sierra RS Cosworth is fitted with the independent semi-trailing arm rear axle, coil springs and double-acting telescopic shock absorbers as known from the Sierra vehicles.
- The rear axle incorporates a viscous-coupling limited-slip differential, which gives full control over wheel-spin and greatly improve traction and roadholding in all driving conditions.
- All components of the Sierra RS Cosworth rear axle which have been modified in comparison to the Sierra are mentioned on the next page.
- **No new special tools are required.**

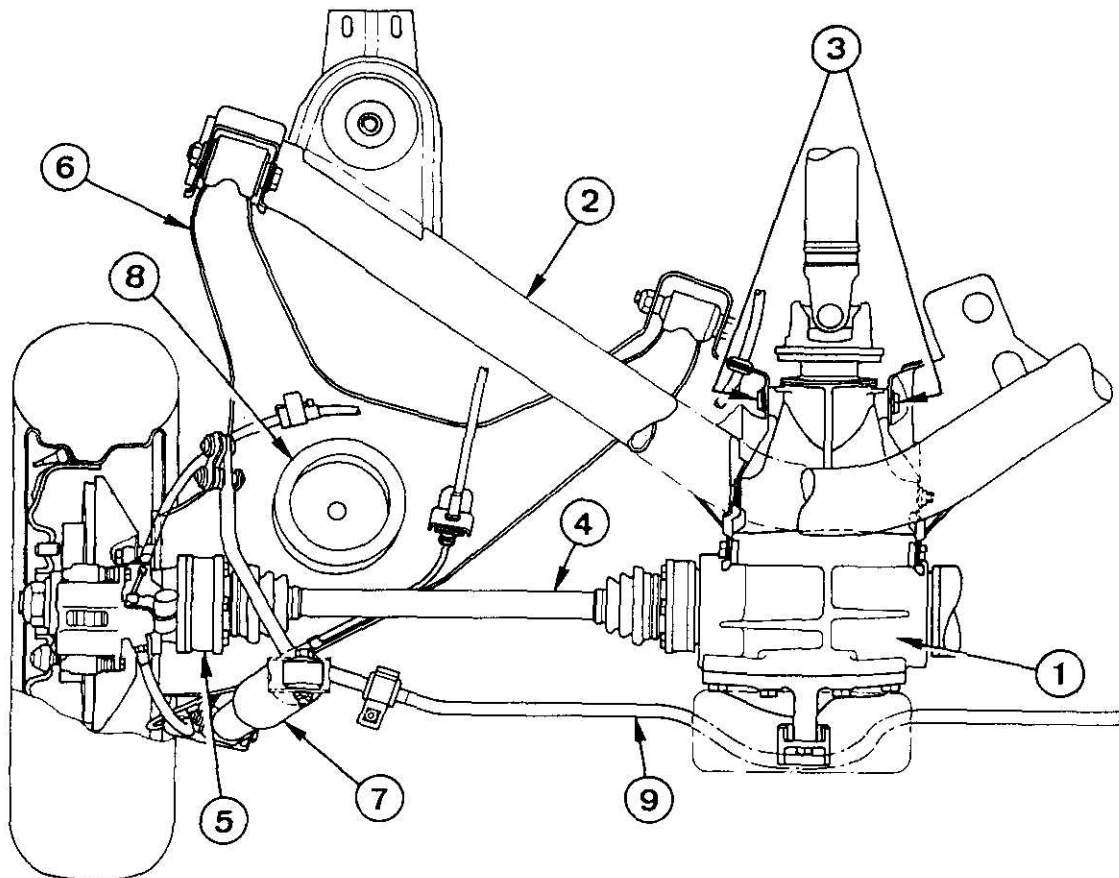

ST/56/18

PART B – Transmission and Rear Axle

2. Rear Axle and Suspension (cont'd.)

The following components have been carried over from Scorpio:

- 1 = 7,5" rear axle assembly with viscous limited-slip differential.
The ratio, 3.64:1, is special to the Sierra RS Cosworth.
- 2 = Rear axle crossmember
- 3 = Fastening – rear axle assembly to crossmember.

The following components have been modified in comparison to the Sierra:

- 4 = Rear axle shafts.
- 5 = Driveshaft stubs.
- 6 = Lower suspension arm.
- 7 = Shock absorbers (as Sierra XR 4 x 4)
- 8 = Coil springs
- 9 = Stabiliser assembly (as Sierra XR 4 x 4)

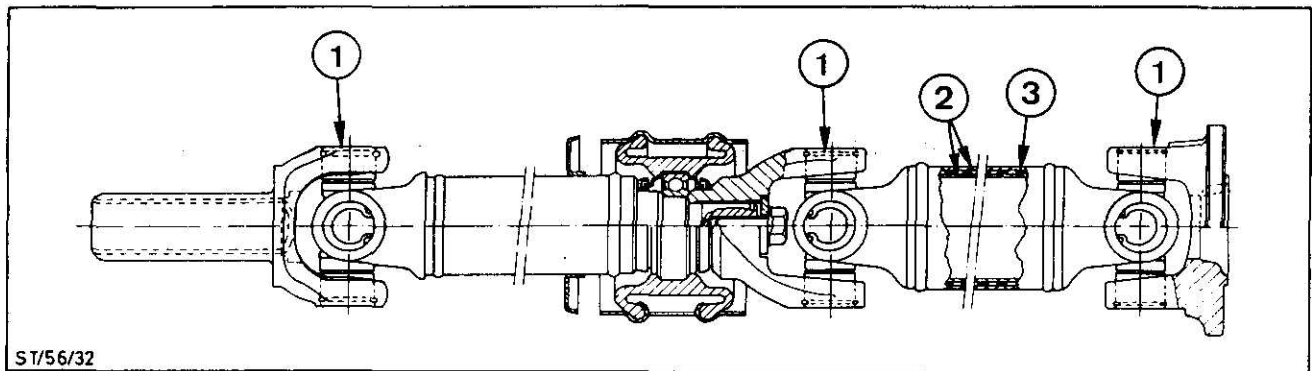

Driveshaft

- 1 = Heavy-duty universal joints
- 2 = Doppel tube
- 3 = Rubber elements

For details see Sierra RS Cosworth Workshop Manual.

PART B – Transmission and Rear Axle

3. Technical Data

Transmission

Ratios

1st Gear	2nd Gear	3rd Gear	4th Gear	5th Gear	Reverse Gear
2.95:1	1.94:1	1.34:1	1:1	0.8:1	2.76:1

Selective Washers – mm (inch)

0.30 (0.012)	0.61 (0.024)	0.79 (0.031)	0.97 (0.038)
0.36 (0.014)	0.64 (0.025)	0.81 (0.032)	0.99 (0.039)
0.41 (0.016)	0.66 (0.026)	0.84 (0.033)	1.02 (0.040)
0.46 (0.018)	0.69 (0.027)	0.86 (0.034)	1.04 (0.041)
0.51 (0.020)	0.71 (0.028)	0.89 (0.035)	1.07 (0.042)
0.56 (0.022)	0.74 (0.029)	0.91 (0.036)	1.09 (0.043)
0.58 (0.023)	0.76 (0.030)	0.94 (0.037)	1.12 (0.044)

End float – countershaft (mm) = 0.025–0.127

– mainshaft (mm) = 0 ± 0.05

Oil capacity (Ltrs.) = 2.6

FORD Specification = SQM 2C 9010 A

For detailed Technical Data and Tightening Torques see Sierra RS Cosworth Workshop Manual.

PART B – Transmission and Rear Axle

3. Technical Data (cont'd.)

Rear Axle

Typ: Independent semi-trailing arm rear axle

Ratio	3.64:1
Oil capacity (Ltrs.)	1.3
Hypoidoil SAE 90	FORD specification SQM 2C 9002 AA
Liquid sealant – rear axle case (1110 B)	FORD specification SQM 4G 9523 A
Grease – bearing housing	FORD specification ESEAM 1C 1014 A
Grease – driveshaft centre bearing	FORD specification SM 1C 4515 A
Wheel bearing grease	FORD specification SAM 1C 9111 A
Grease capacity – tripod drive joints – FORD specification	100 ± 10 g S-M1 C75-A or SQM-1C 9004 A or Mobil Rex E 22 grease

For detailed Technical Data and Tightening Torques see Sierra RS Cosworth Workshop Manual.

PART C - Front Axle and Suspension

The Sierra RS Cosworth has McPherson strut front suspension, similar to that used in Sierra and Scorpio model ranges.

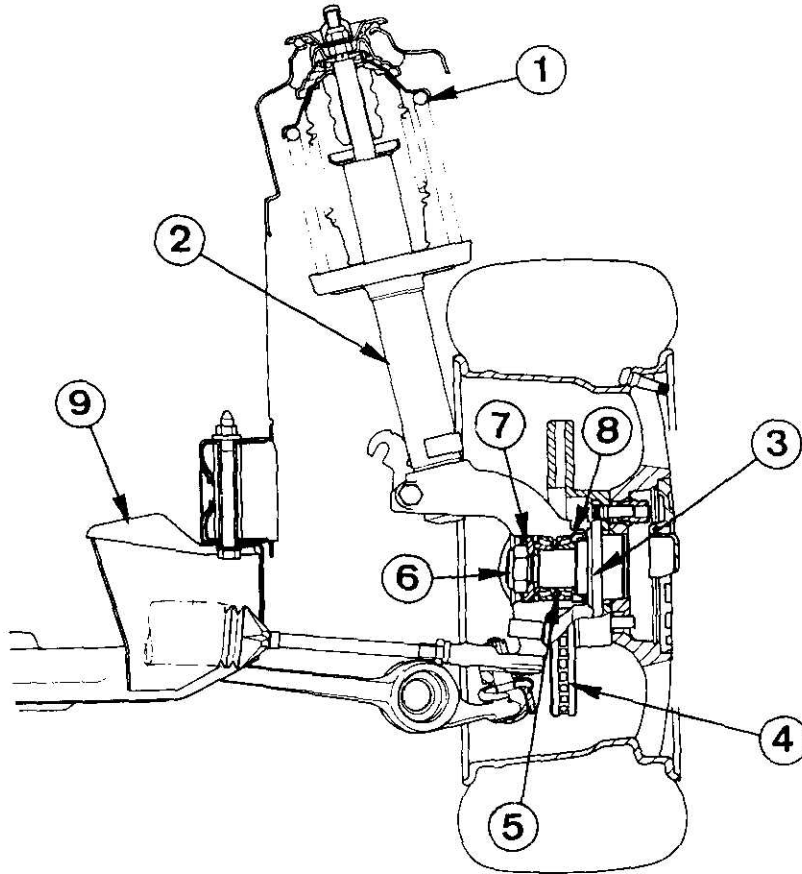

ST/56/33

ACM

Front axle and suspension - cross section

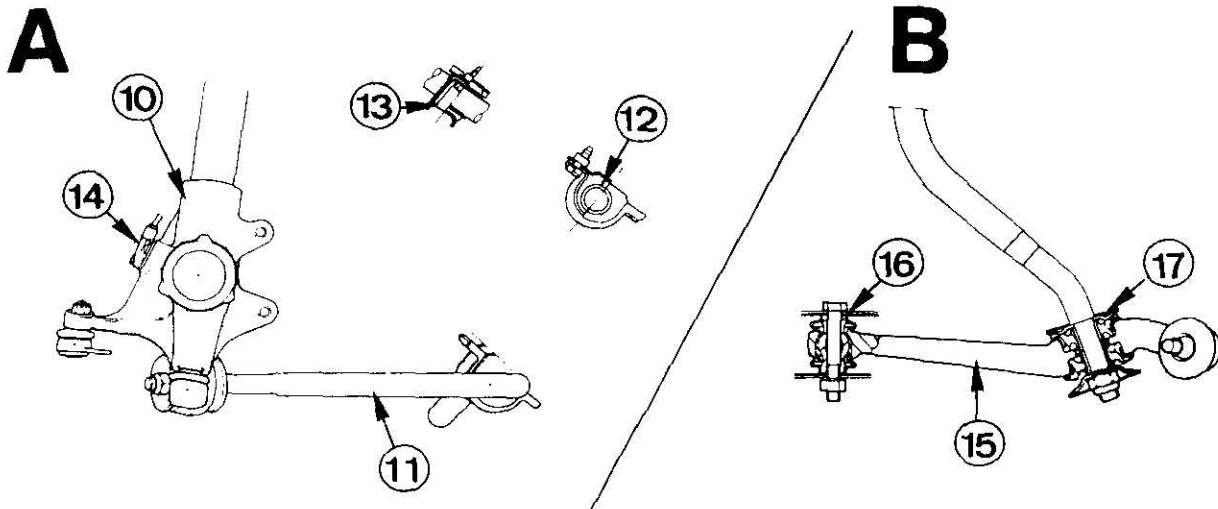

ST/56/94

A = Spindle carrier and stabiliser mounting

B = Lower arm mounting

PART C – Front Axle and Suspension

- Some parts of the front axle and suspension have been reinforced or modified in order to meet with the increased requirements of road holding.
- The front wheel alignment should be checked as described in the Sierra Workshop Manual.
- Only toe setting is adjustable.
- **No new special tools are required.**
- In the list below, front axle and suspension components, which are reinforced or modified in comparison to the Sierra, are marked with "Sierra RS Cosworth". Scorpio components which have been carried over to the Sierra RS Cosworth are marked with "Scorpio" (refer to illustration on page 66).

1 = Spring	Sierra RS Cosworth
2 = Strut	Sierra RS Cosworth
3 = Hub	Sierra RS Cosworth
4 = Brake disc	Sierra RS Cosworth
5 = Front wheel bearings	Scorpio
6 = Protection cap	Scorpio
7 = Toothed rotor (ABS)	Scorpio
8 = Grease seal	Scorpio
9 = Crossmember	Sierra RS Cosworth
10 = Spindle carrier	Sierra RS Cosworth
11 = Stabiliser bar, 28 mm diameter	Sierra RS Cosworth
12 = Bush	Scorpio
13 = U-Clamp and fixing	Sierra RS Cosworth
14 = Anti-lockwheel sensor with fixing	Scorpio
15 = Lower arm	Sierra RS Cosworth
16 = Attachment-lower arm to crossmember	Scorpio
17 = Rear cover	Scorpio

Wheel Alignment (unladen)

Toe setting (toe-in)	1,0 mm ± 1,0 mm
Castor	2° 30' ± 0° 30'
Camber	-1° 15' ± 0° 30'

Maximum variation Left hand to Right hand:

Castor	1° 0'
Camber	1° 15'
Front wheel bearing grease	Ford Spezifikation SAM 1C 9111 A

For detailed Technical Data and Tightening Torques see Sierra RS Cosworth Workshop Manual.

PART D – Anti-Lock Braking System (ABS)

1. General Description

- The Sierra RS Cosworth is fitted with the Anti-Lock Braking System (ABS), which is similar to the system used on the Sierra XR 4 x 4.
- The principle of operation of these systems are described in detail in the following publications:
 - Technicians Information CG 7216,
 - A Technical Introduction for Workshop Staff (Scorpio/Granada),
 - Sierra XR 4 x 4 Workshop Manual.
- No new special tools and test equipment are required for the Sierra RS Cosworth Anti-Lock Braking System.
- This part of the brochure includes a brief summary about the principles of operation of the ABS and informs you about the modified components of the Sierra RS Cosworth Anti-Lock Braking System.

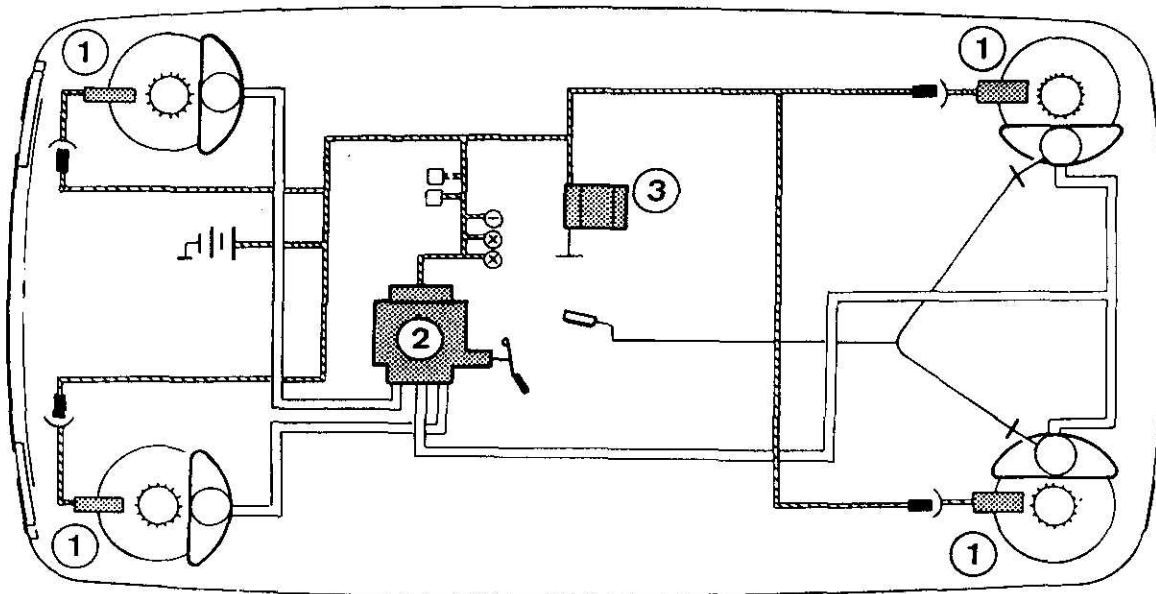

1 = Wheel Sensors

2 = Actuation Assembly

3 = ABS-Module

PART D – Anti-Lock Braking System (ABS)

1. General Description (cont'd.)

Principles of Operation

- A dual circuit braking system is used, with the front wheels on a separate circuit to the rear wheels.
- The brake system does *not* operate with vacuum boost but with an integral hydraulic booster by using accumulator pressure.
- The heart of ABS is the actuation assembly.
- The front wheel brakes are activated by a single piston master cylinder.
- The rear wheel brakes are activated by controlled accumulator pressure.
- The accumulator pressure is produced by an electric pump forcing brake fluid against the diaphragm of a gas filled pressure accumulator which forms part of the actuation assembly.
- ABS uses an electronically controlled system to sense any tendency for a wheel to lock and *instantly adjusts brake line fluid pressure to the affected wheel to maintain optimum braking.*
- The system has all round power assisted disc brakes with ventilated front discs and solid rear discs.
- Each brake assembly has a sensor which constantly monitors the rotational speed of the wheel.
- A magnetic field within the sensor is interrupted by a toothed rotor which turns with the wheel of the car. This produces an *electrical signal.*
- The sensors send a constant stream of signals to the ABS module which contains two identical micro-processors. These constantly monitor and compare incoming signals from all four wheel sensors.
- If during braking lock-up of one wheel becomes imminent, the sensor signal from that wheel will differ from signals from other wheels.
- The ABS module reads this difference and instructs the actuation assembly to adjust hydraulic pressure to the affected wheel.
- Constant adjustment of pressure at this wheel is maintained until the module interpretes the same rate of deceleration by all four wheels.

PART D – Anti-Lock Braking System (ABS)

2. The Sierra RS Cosworth Anti-Lock Braking System

Modified Components

The following components have been modified to suit Sierra RS Cosworth.

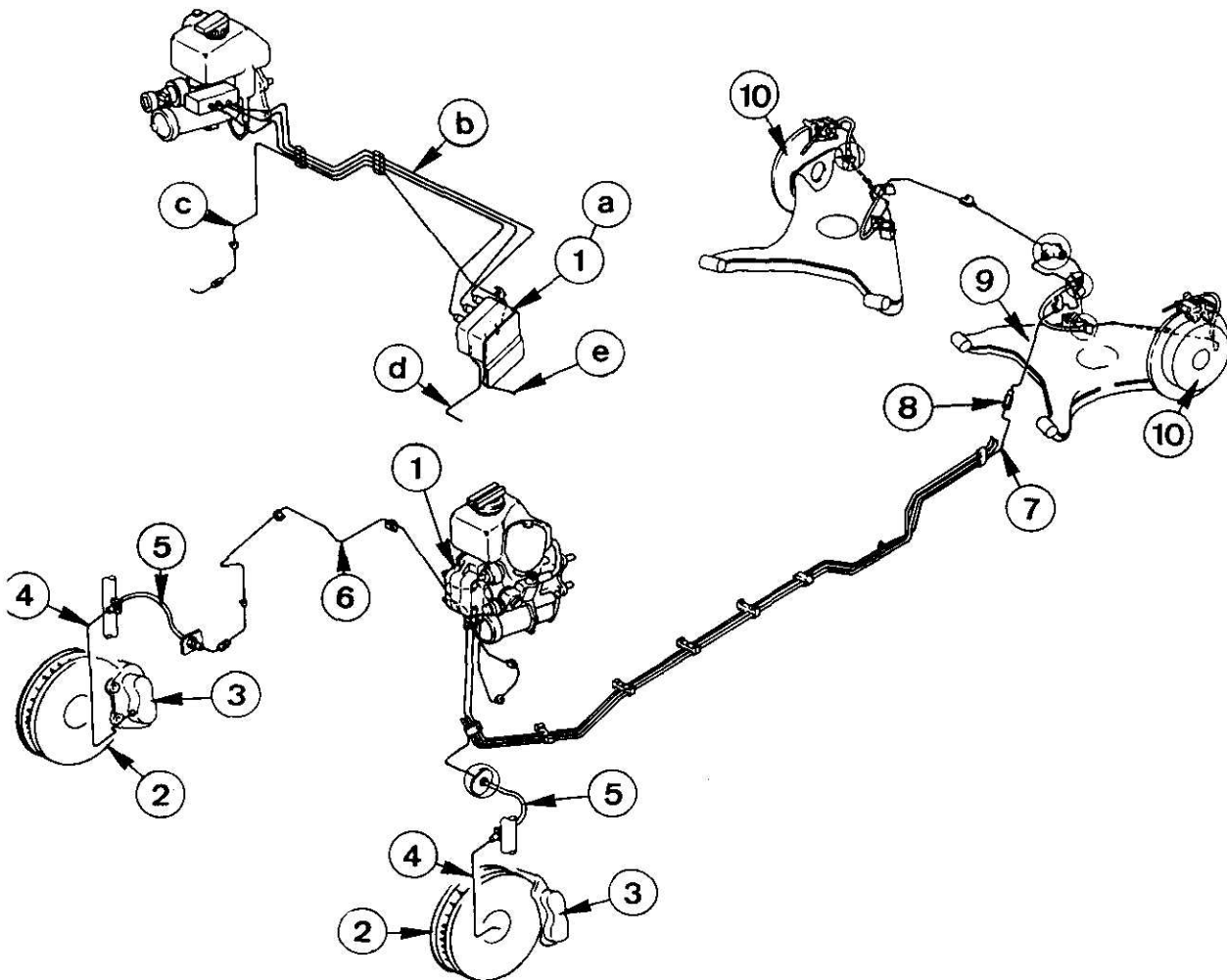

ST/56/115

- 1 = Valve block
Due to lack of space the valve block on **RHD-versions** is fitted separately to the left fender apron and connected to the actuation assembly by brake lines.
- 2 = Front brake discs
- 3 = Front caliper assembly and brake pads
- 4 = LH/RH front brake line
- 5 = LH/RH front brake hose

PART D – Anti-Lock Braking System (ABS)

2. The Sierra RS Cosworth Anti-Lock Braking System

Modified Components (cont'd.)

- 6** = Front brake line (connection from RH front brake line to actuation assembly)
 - 7** = Brake line (from actuation assembly to brake pressure regulator valve)
 - 8** = Brake pressure regulator valve
This valve is new. It has been fitted in the rear braking circuit in order to prevent premature pressure build up to the rear brakes.
 - 9** = Brake line (from brake pressure regulator valve to T-connector)
 - 10** = Rear brake discs and brake pads.
- All other components are carried over from Sierra XR 4 x 4 or Scorpio.

Components for the RHD-Version, which differ from those fitted to the LHD-Version, are shown in illustration on page 70 and listed below:

- a)** Valve block
- b)** Three brake lines between actuation assembly and valve block
- c)** Front brake line (from valve block to RH-brake hose)
- d)** Front brake line (from valve block to LH-brake hose)
- e)** Rear brake line (from valve block to brake pressure regulator valve)

PART D – Anti-Lock Braking System (ABS)

2. The Sierra RS Cosworth Anti-Lock Braking System (cont'd.)

System Components and Location

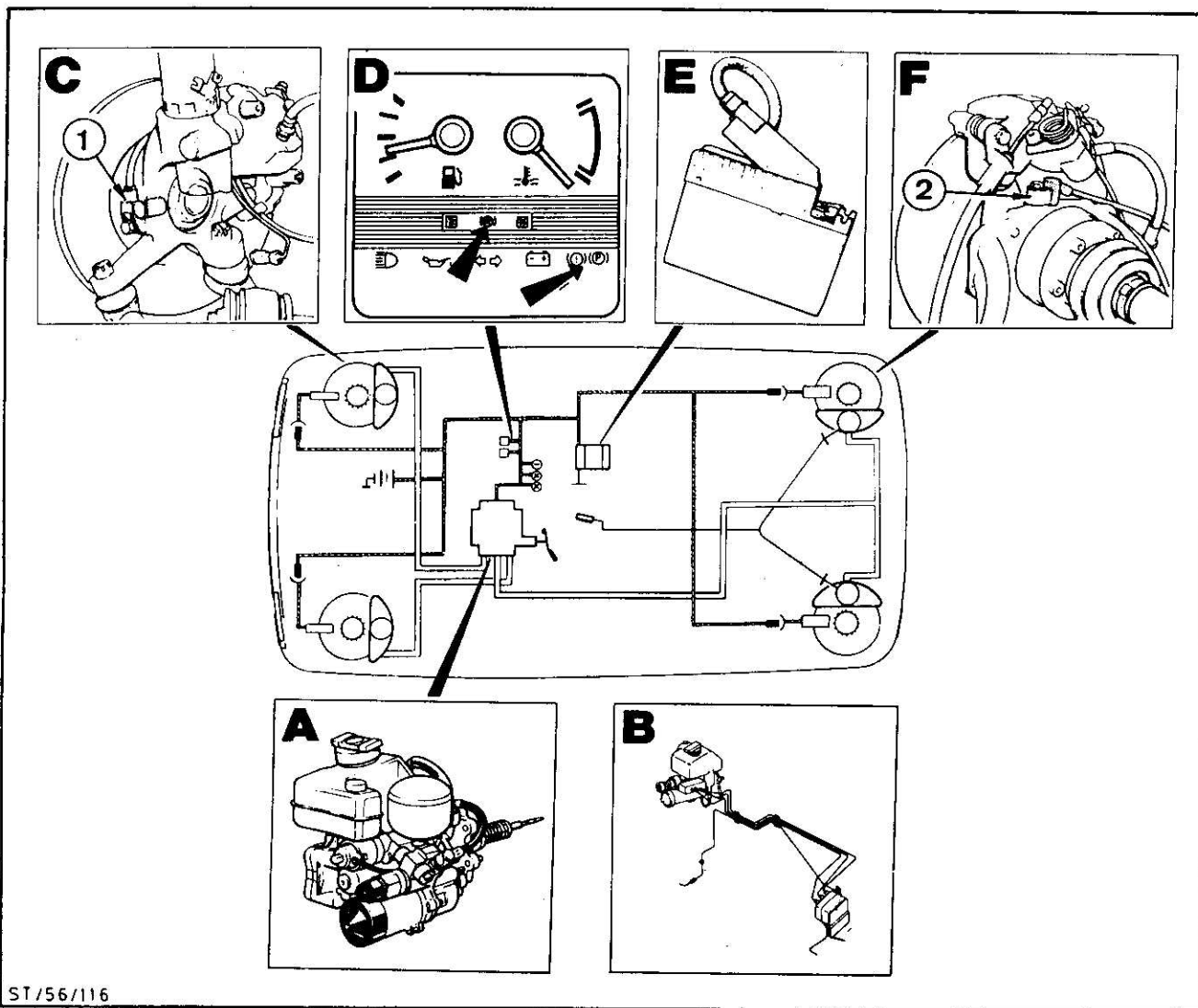

- A** = Actuation assembly (LHD-Version).
Installed in the engine compartment on the bulk head.
- B** = Actuation assembly (RHD-Version).
The valve block of the actuation assembly is fitted separately to the left fender apron.
- C** = Front wheel brake system.
The wheel sensors (1) are fitted to the front spindle carrier.
- D** = Warning and safety system.

PART D – Anti-Lock Braking System (ABS)

2. The Sierra RS Cosworth Anti-Lock Braking System

System Components and Location (cont'd.)

Two warning lights are situated on the facia panel.

- The ABS and brake warning lights (low brake fluid level, low accumulator pressure).
- The handbrake warning light.

E = ABS-Module.

This sealed "black box" is located behind the instrument trim panel on the driver side of the vehicle. When defective it must be renewed.

F = Rear wheel brake system.

The wheel sensors (2) are mounted in the end castings of the rear suspension arms.

3. Technical Data

Dual circuit braking system

– front wheel left/right separately controlled
– rear wheels controlled together

Brake discs	Front	Rear
Typ	ventilated discs	solid discs
Disc diameter	260.0 mm	254.0 mm
Disc run out	0.15 mm	0.01 mm
Minimum disc thickness	22.7 mm	8.9 mm
Maximum thickness variation	0.01 mm	0.01 mm
Brake fluid-amber	SAM-6C-9101-A or C	

For detailed Technical Data and Tightening Torques see Sierra RS Cosworth Workshop Manual.

PART E – Body Features, Wheels and Tyres

1. Exterior dress up, Wheels and Tyres

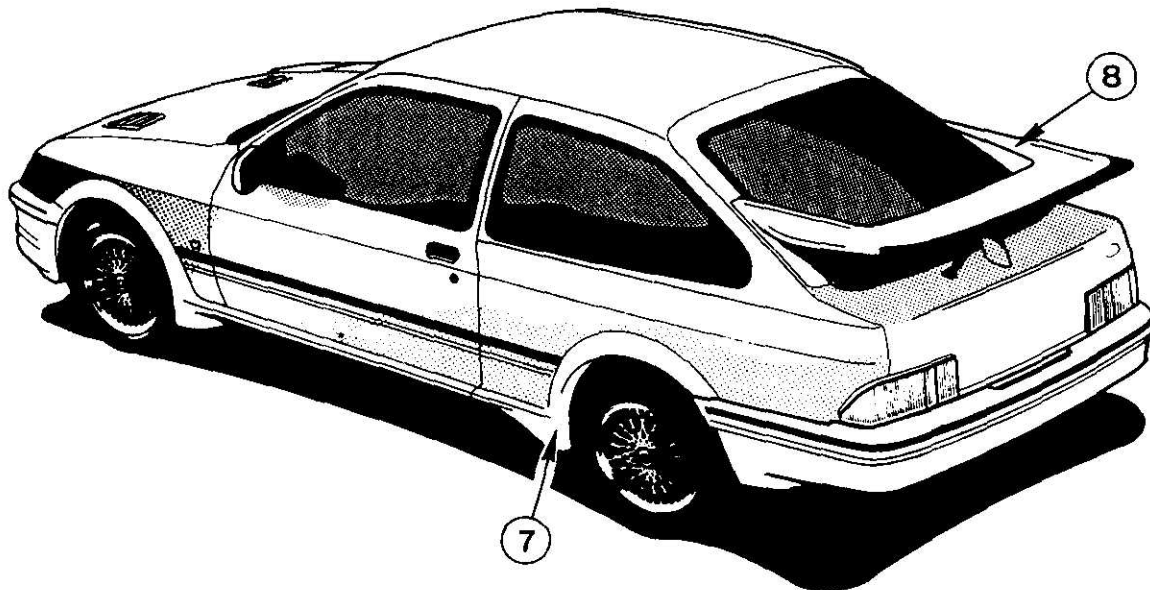
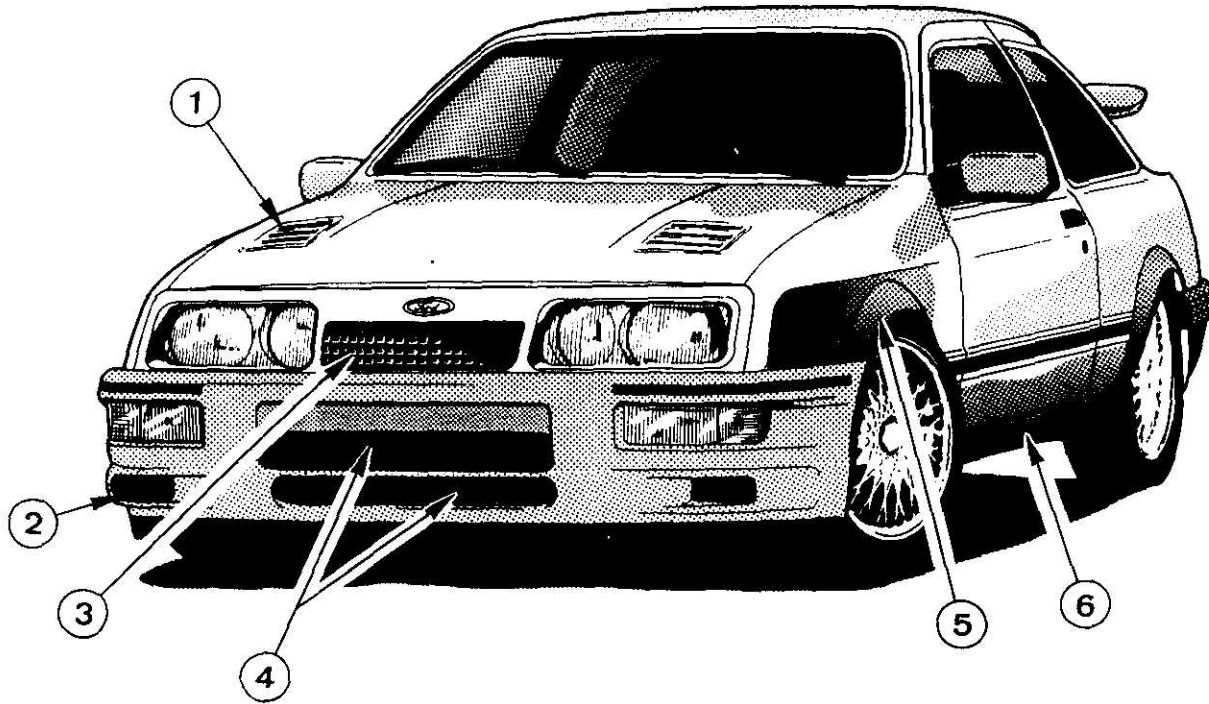

PART E – Body Features, Wheels and Tyres

1. Exterior dress up, Wheels and Tyres (cont'd.)

- 1** = Air extraction grilles for improved cooling.
- 2** = Slots for brake cooling.
- 3** = New radiator grill with a single large cooling slot for the intercooler.
- 4** = Large cooling slots for the radiator.
- 5** = Extension for front wheelarches.
- 6** = Moulding-rocker panel.
- 7** = Extension for rear wheelarches.
- 8** = Special rear spoiler with three mounting points to tailgate.

Important:

- Because of the special configuration of some body/trim panels, in particular the special rear-spoiler, the vehicle must under no circumstances be driven through an automatic car wash.
- The stone deflector of the frontbumper will not be installed during production, to avoid shipping damage. It should be installed during PDI.

Wheels and Tyres

15" x 7" racing style light alloy road wheels with lockable hub cover.

205/50 VR 15 – tyres

Cold Tyre Pressure	Front	Rear
Normal laden and normal usage (Bar)	2.1	2.3
Fully laden and normal usage (Bar)	2.3	2.5

When operating at sustained high speed, in the normal laden condition, the tyre pressure must be increased by 0.1 Bar for every 10 km/h (6 mph) above 160 km/h (100 mph).

PART E – Body Features, Wheels and Tyres

2. Interior features

- Recaro front bucket seats.
- Sport steering wheel.
- Modified instrument panel.

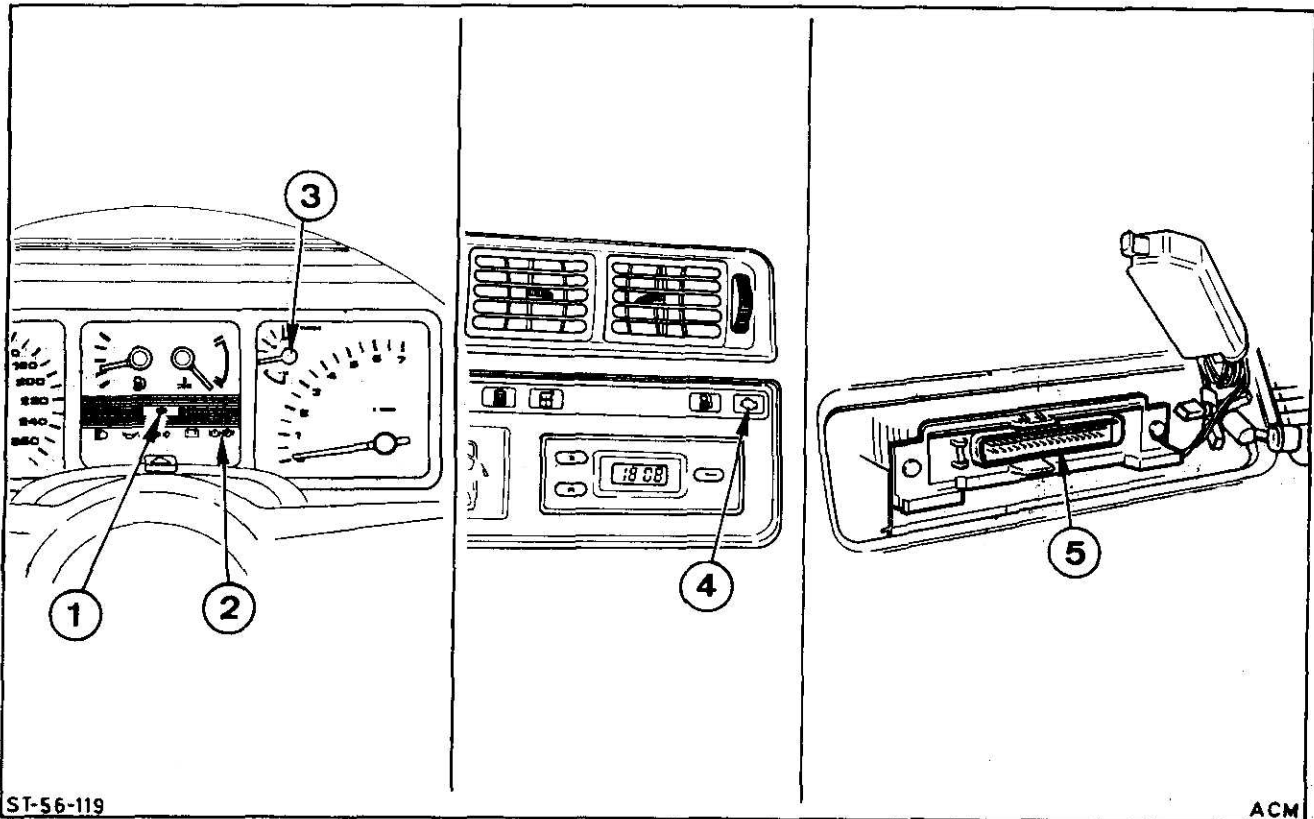

ST-56-119

ACM

- 1 = ABS/Brake warning light
- 2 = Handbrake warning light
- 3 = Boost pressure gauge
- 4 = Electronic engine control system-warning light
- 5 = Location of ECU with CO adjusting screw, cable for octane adjust and self test connector