

INDEX

GENERALITIES

- Description	1
- Lubrication	3

OVERHAULING

- Introduction	4
- Engine dis - assembly	4
- Dis - assembly of cylinder heads	10
- Checks and inspections cylinder heads	11
- Checks and inspections crankcase	15
- Cautions for re - assembly	19
- Checking the electrical components of the lubrication circuit	22

DESCRIPTION

The engine has 4 opposed cylinders, double camshaft for each cylinder head, two valves per cylinder controlled by hydraulic tappets and BOSCH MP3.1 multipoint electronic injection and static ignition for the 1.6 engine and IAW for the 1.3 engine.

The clutch - gearbox - differential unit is connected behind the engine and forms an integral part of the power unit.

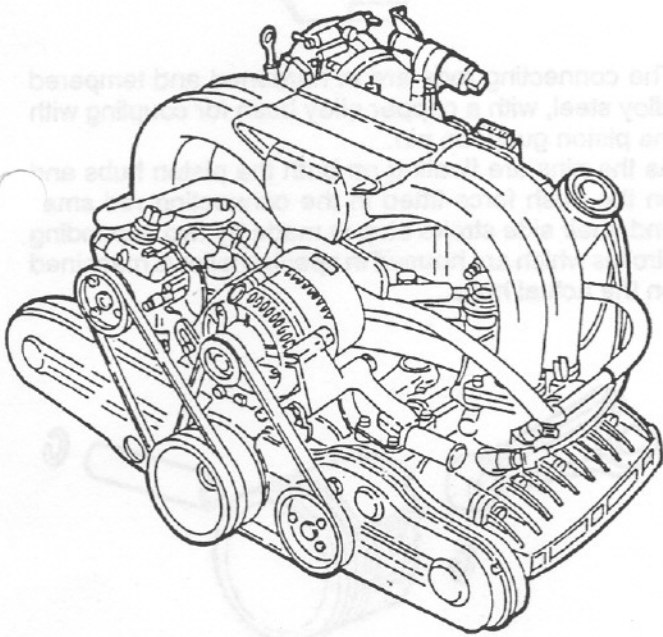

The latter is front mounted and set longitudinally with a 3° inclination.

The power unit is fastened to the body by "suspension" type mounts through a support frame connected to the gearbox - differential unit. The various connections of the power unit to the support frame and to the rear support are made with appropriate flexible mounts to absorb engine vibrations.

The fuel supply system, with unleaded petrol, combined with the suitable antipollution systems described in the specific paragraphs, ensure low exhaust emission levels meeting "USA 83" regulations.

CRANKCASE

This is a single cast iron block with high mechanical strength.

The crankshaft is supported by 3 main bearings which house the same number of thin-walled half bearings. The cylinders are machined directly in the crankcase and they are selected in five classes of dimensions. If cylinder wear exceeds the specified values, they must be bored to the specified diameters according to the oversizes of the pistons available from Spares (see CPT).

Special grooves machined in the crankcase walls allow the circulation of coolant fluid and lubricating oil.

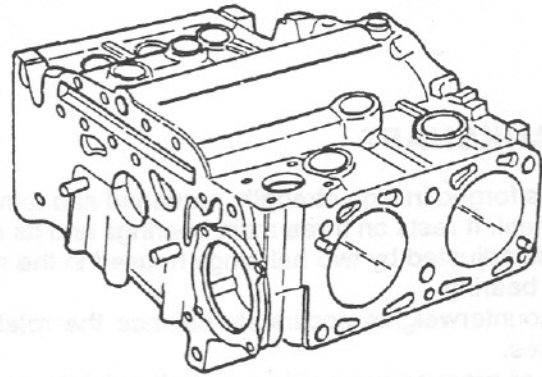

Oil spray jets installed on the front and centre main bearing caps spray oil on the piston crowns to partially cool them.

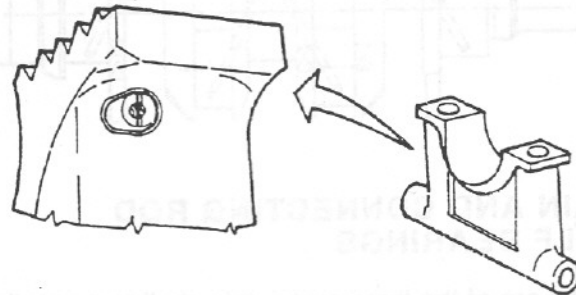

CYLINDER HEADS

This is one-piece, compact and chill-cast in aluminium and silicium alloy.

The camshaft bearings are fastened on the cylinder heads, these too, are made from aluminium and silicium alloy.

The camshafts, controlled through toothed belts, turn on three supports.

The valve guides are force-fitted in their housings on the cylinder heads by interference and the inside diameter is perfected after assembly using a specific reamer and checked using a pair of no-no go gauges. The seals between the cylinder heads and crankcase are of the ASTADUR type.

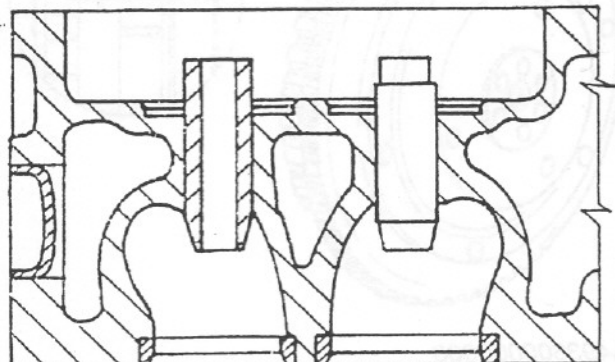



Due to the special material with which they are made, these seals are polymerized when the engine is running and harden considerably during use, therefore it is no longer necessary to tighten the cylinder heads at the first service coupon.

CRANKSHAFT

This is forged in high-strength, hardened and tempered steel. It rests on three main bearings and its end float is adjusted by two half rings housed in the rear main bearing.

Six counterweights accurately balance the rotating masses.

A set of grooves run inside the shaft to lubricate the main and connecting rod journals.

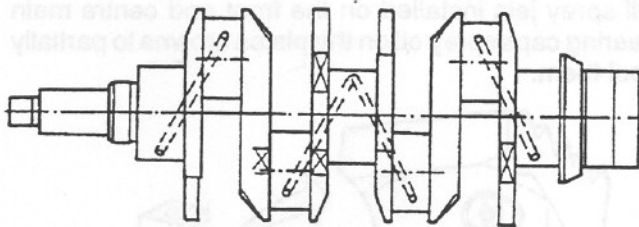

MAIN AND CONNECTING ROD HALF BEARINGS

These are of the three-metal, thin shell type subdivided into two dimensional classes.

The main half bearings have a hole and groove for lubricating the rod journals.

FLYWHEEL

This is in cast iron, with two ring gears in hardened and tempered steel: one for connection with the starter motor and one for the rpm sensor facing it.

The "T" notch for checking engine timing is stamped on the flywheel.

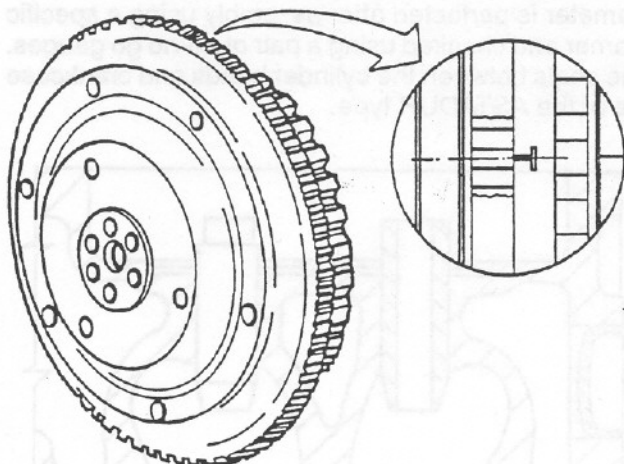

PISTONS AND CONNECTING RODS

The pistons in aluminium silicium alloy are subdivided into five dimensional classes and they are available as Spares in three other oversize classes.

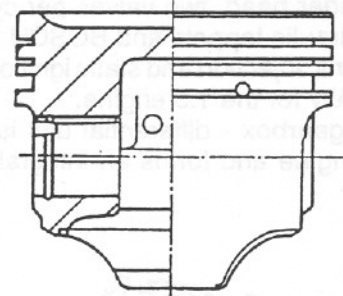

The connecting rods are in hardened and tempered alloy steel, with a copper alloy bush for coupling with the piston gudgeon pin.

As the pins are floating on both the piston hubs and on the bush force-fitted in the connecting rod sma end, their side stroke stop is made by two expanding circlips which are housed in special hollows machined on the actual hubs.

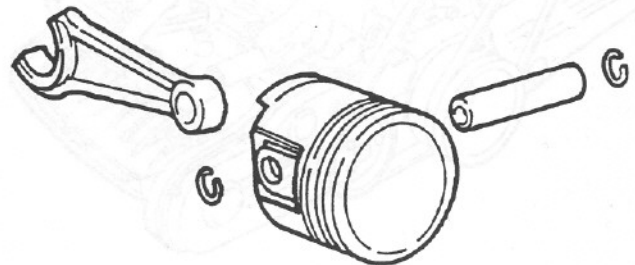

The right cylinder head pistons are positioned with the arrow stamped on the piston crown facing upwards and those of the left cylinder heads with the arrow pointing downwards.

TIMING

Direct drive by toothed belts, with overhead camshafts in case-hardened alloy steel. The hydraulic tappets in contact with the cams operate the valves directly.

This device, which has also been adopted in the 1712 16V, automatically eliminates "valve play" when the engine is running, thereby enormously reducing the need for periodic maintenance. The exhaust valve stem is chromium-plated and inside it has a hollow filled 50 + 60% with sodium which improves dispersion of the heat to which they are subjected.

The valve seats are sintered in material suitable for use with unleaded petrol.

LUBRICATION

Lubrication is forced by gear pump. The oil pump is fitted on the rear engine cover and it is operated by a shaft that receives motion from a gear installed behind on the crankshaft. The oil withdrawn from the sump through a suction device is filtered by the mesh filter on the actual suction device and then sent under pressure by the pump through a groove to the oil filter with full-flow cartridge fitted with a safety by-pass valve which ensures that the oil can still pass if the filter is clogged.

The maximum lubricating pressure is adjusted by a special limiting valve fitted on the pump. After being filtered, the oil flows through a transversal duct into the main longitudinal delivery duct machined in the crankcase. From here, it is ducted through three grooves to the lubricating grooves of the crankshaft main and rod bearings.

To improve cooling of the pistons on the right main bearing spray jets have been fitted on the front and centre main caps.

Through two transversal grooves and suitable branches machined in the crankcase and cylinder heads the oil reaches the camshaft bearings and allows the hydraulic tappets to work.

The cylinder head lubrication oil gathered in the trays of the camshaft bearings and the lubrication oil of the main and rod journals falls back into the sump.

The lubrication system is fitted with an oil vapour recirculation system which recovers the vapours coming from the sump.

Low oil pressure is signalled by a warning light on the dashboard connected to a sensor inserted on the rear engine cover.

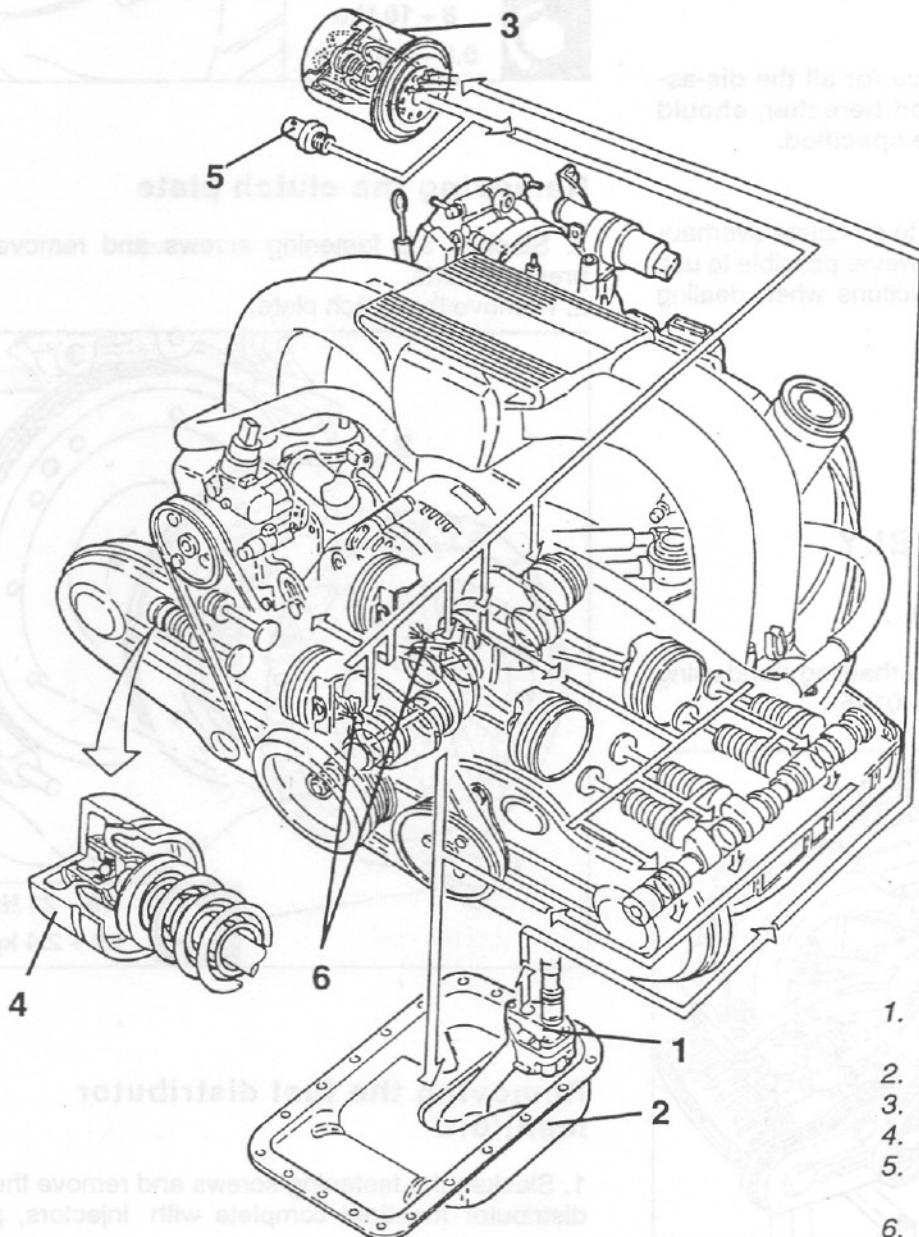

1. Oil pump with pressure limiting valve
2. Oil sump
3. Oil filter with by-pass valve
4. Hydraulic tappet
5. Low oil pressure warning light sensor
6. Spray jets

INTRODUCTION

The instructions given in the following paragraphs refer to the complete overhaul of the engine on the bench, after removing the power unit from the engine. The instructions are subdivided as follows:

- **Dis-assembly of the engine:**
removal of the engine accessories and components and dis- assembly into its main component parts.
- **Dis-assembly and checks of the crankcase:**
complete overhauling of the crank mechanisms.
- **Cautions for re-assembly:**
these include specific re-assembly operations where they differ substantially from the instructions for dis-assembly.
- **Checks and inspections of electrical components of the lubrication circuit.**

For re-assembly, the sequence for all the dis-assembly instructions described hereafter, should be reversed unless otherwise specified.

The following procedures refer to complete overhauling of the whole engine; it is however possible to use individual parts of these instructions when dealing with specific components.

ENGINE DIS-ASSEMBLY

Preliminary operations

1. Set the engine on a special overhauling stand using supports N° 1.820.609.000 (R.4.0145).

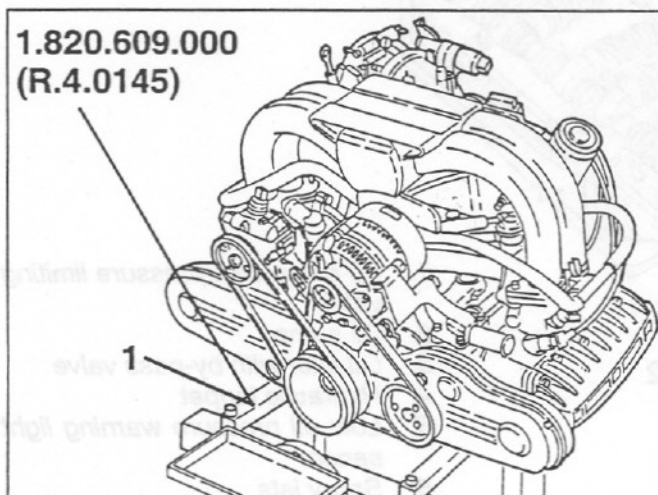

Removing the rpm sensor

1. Slacken the fastening screw and remove the sensor.

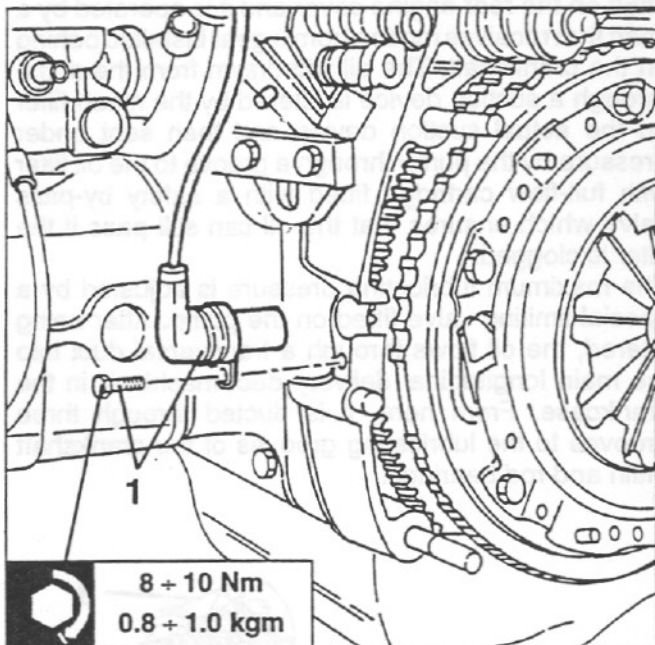

Removing the clutch plate

1. Slacken the fastening screws and remove the pressure plate.
2. Remove the clutch plate.

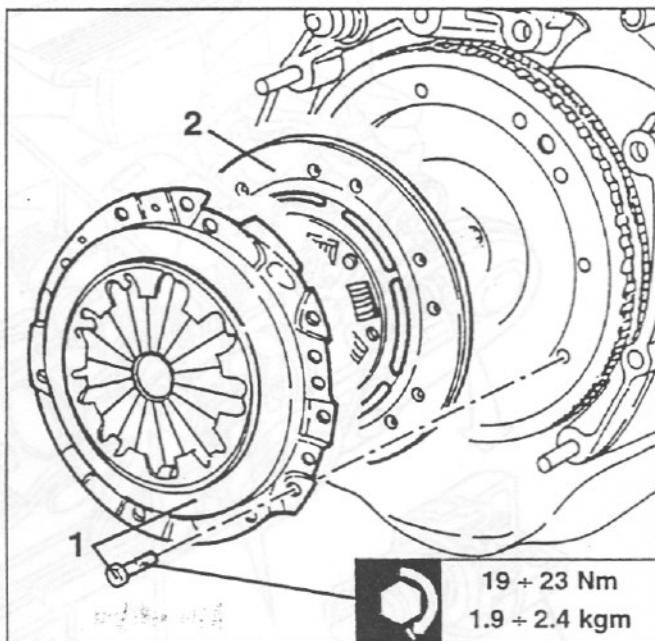

Removing the fuel distributor manifold

1. Slacken the fastening screws and remove the fuel distributor manifold complete with injectors, pulse

damper and pressure regulator.

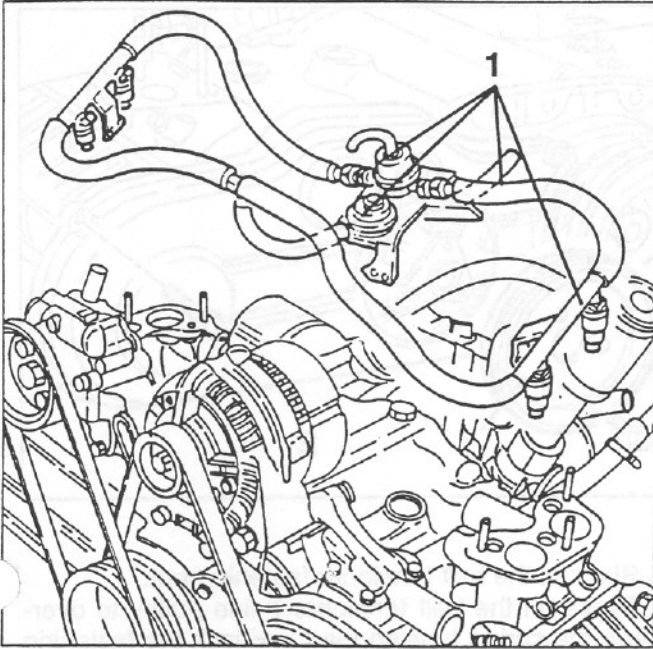

2. Completely unscrew the screws slackened previously and remove the power steering pump.

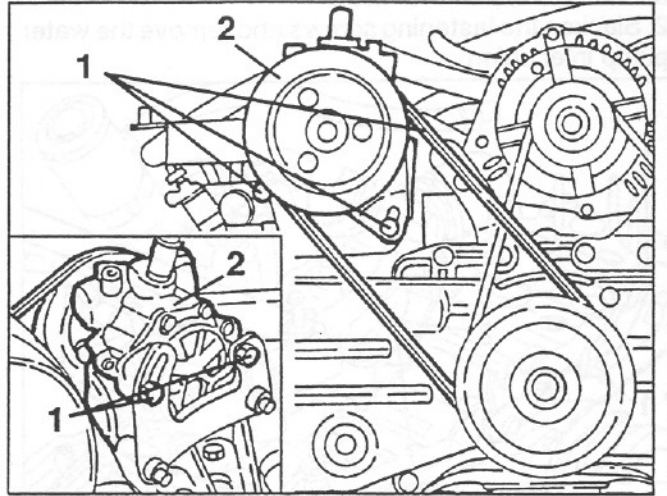

1. Slacken the two fastening screws and remove the power steering pump support bracket.

Removing the thermostat unit

1. Disconnect the coolant outlet pipes from the intake manifolds.
2. Disconnect the pump-thermostat connection pipe from the coolant inlet union.
3. Slacken the fastening screw and remove the thermostat unit complete with hoses.

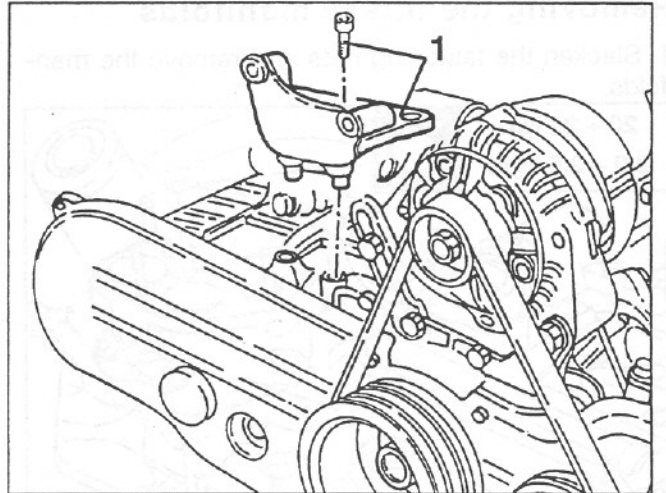
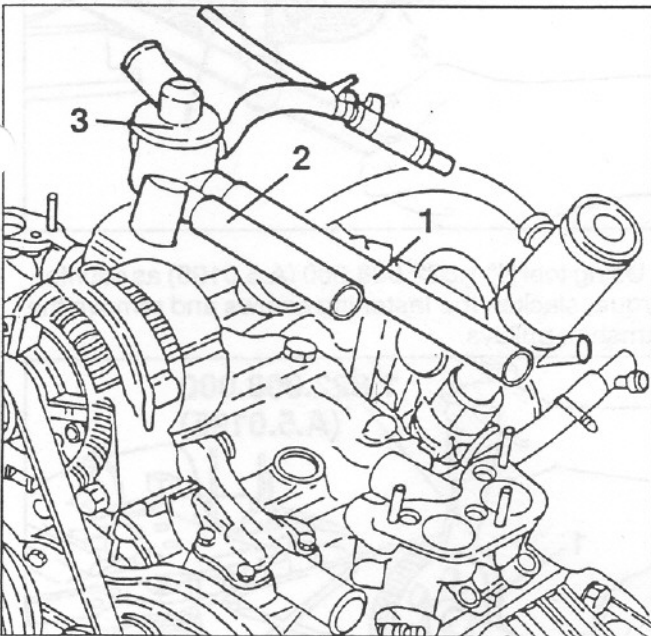

Removing the alternator

1. Slacken the two alternator fastening bolts; prise and remove the drive belt.
2. Completely back off the two bolts slackened previously and remove the alternator.

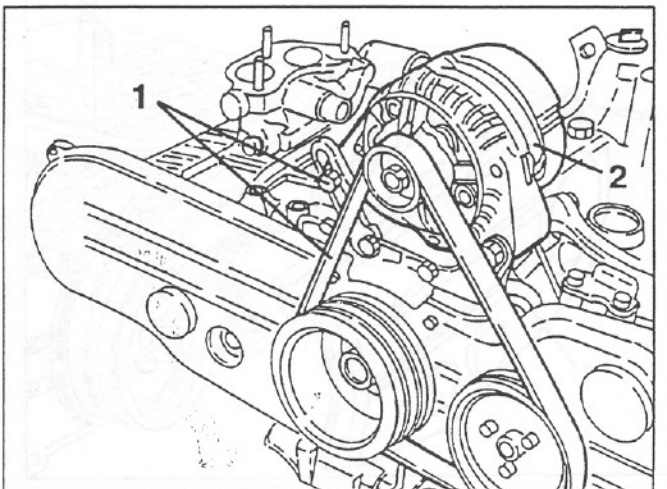

Removing the power steering pump

1. Slacken the power steering pump fastening screws; prise and remove the drive belt.

Removing the brackets

1. Slacken the fastening screws and remove the alternator support brackets.
2. Slacken the fastening screws and remove the water pump inlet union.

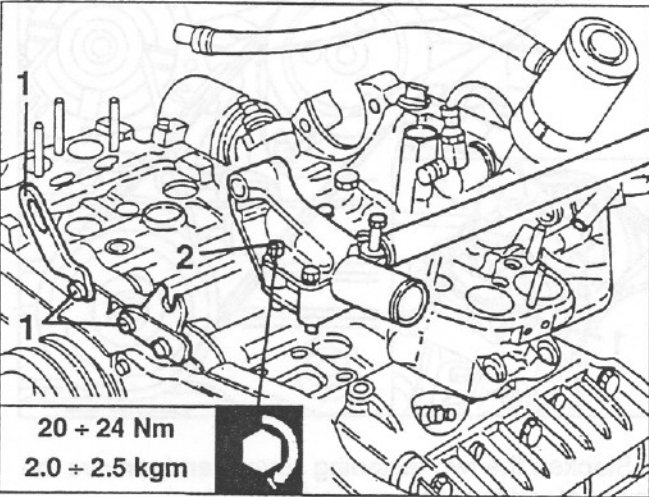

Removing the intake manifolds

1. Slacken the fastening nuts and remove the manifolds.

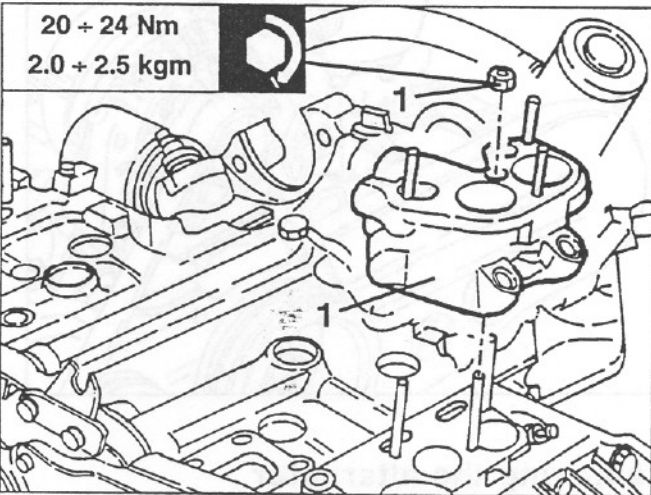

Removing the pulleys

1. Slacken the fastening screws and remove the right timing belt front cover.

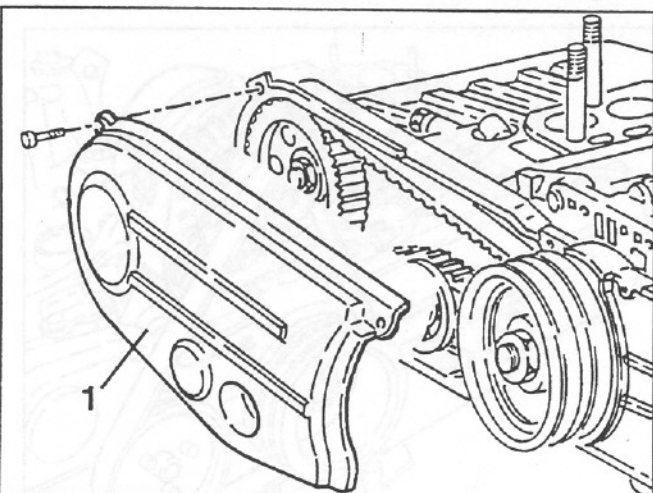

1. Remove the water pump pulley.
2. Remove the left front guard.

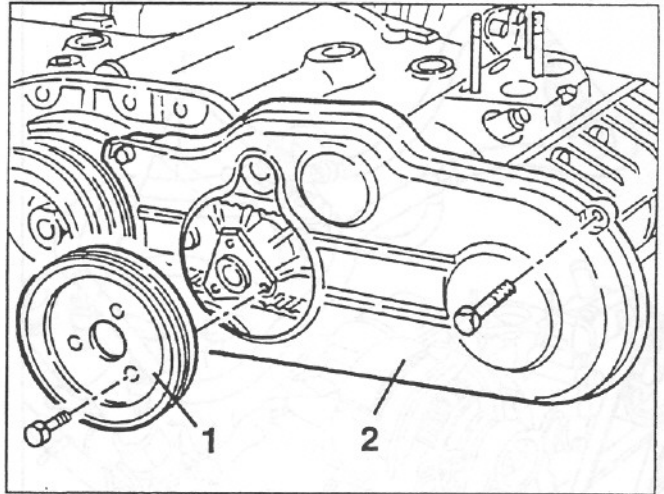

1. Slacken the belt tensioner fastening nut.
2. Press on the belt tensioner guide pulley to overcome the spring tension load and lock the fastening nut.
3. Remove the timing belt firstly from the camshaft pulley and then from the crankshaft pulley.

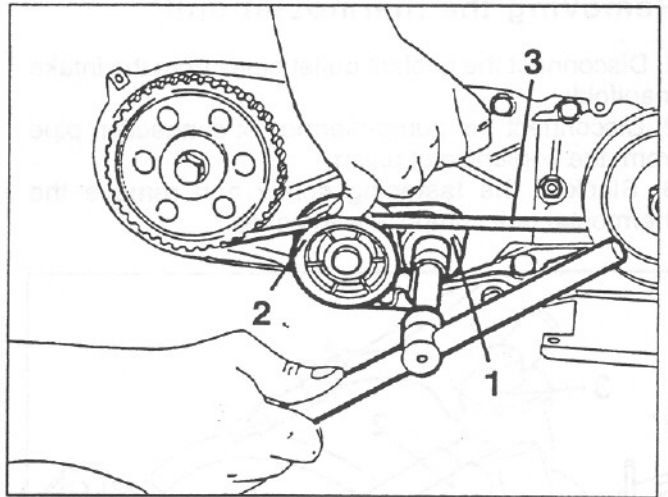

1. Using tool N° 1.822.008.000 (A.5.0195) as counter-torque, slacken the fastening screws and remove the camshaft pulleys.

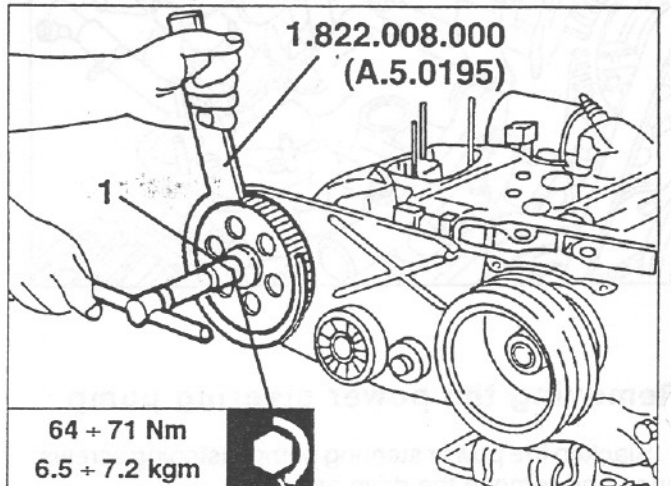



1. Slacken the fastening nuts and remove the belt tensioners.
2. Slacken the fastening screws and remove the timing belt rear guards.
3. Slacken the fastening screws and remove the water pump with its seals.

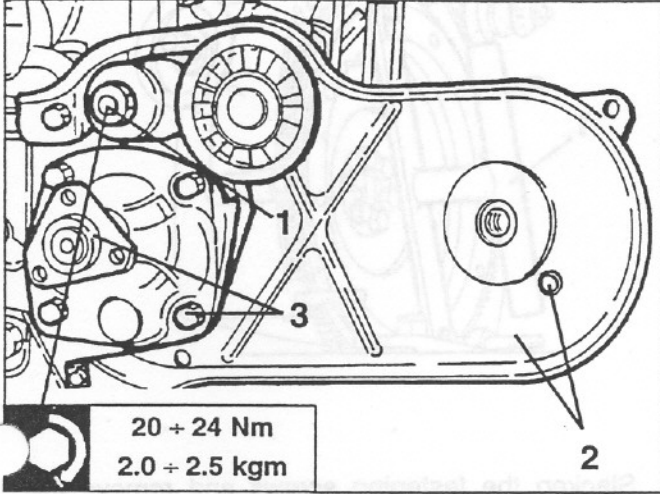

Removing the crankshaft pulleys

1. Using tool N° 1.820.059.000 (A.2.0378) prevent the flywheel from turning.

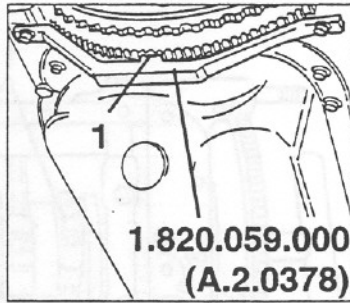

1. Slacken the four fastening screws and remove the front flexible support.

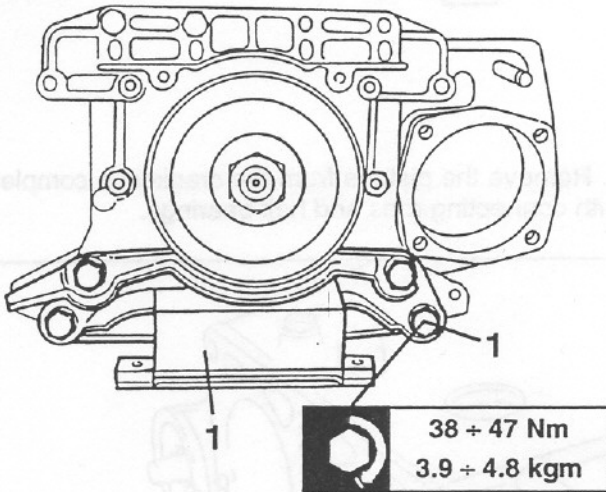

1. Slacken the fastening nut and remove the auxiliary drive pulley.
2. Remove the right timing belt toothed pulley.
3. Remove the spacer.
4. Remove the left timing belt drive pulley.

5. Remove the belt contact washer.

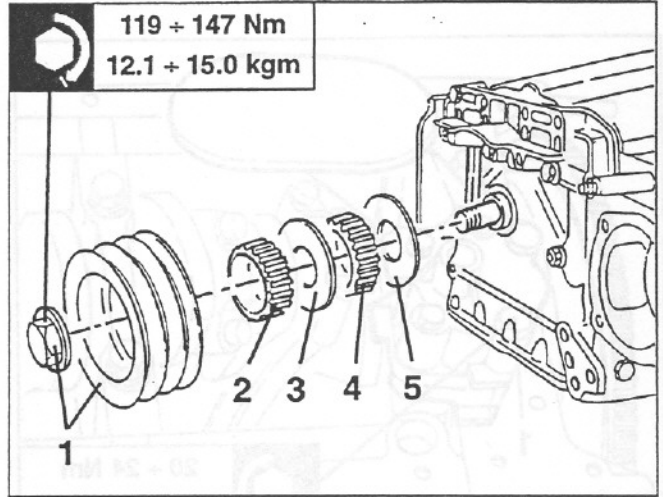

- Remove tool N° 1.820.059.000 (A.2.0378) fitted previously to lock the flywheel.

Removing the cylinder heads

1. Slacken the fastening screws and remove the cylinder heads from the crankcase with their seals.

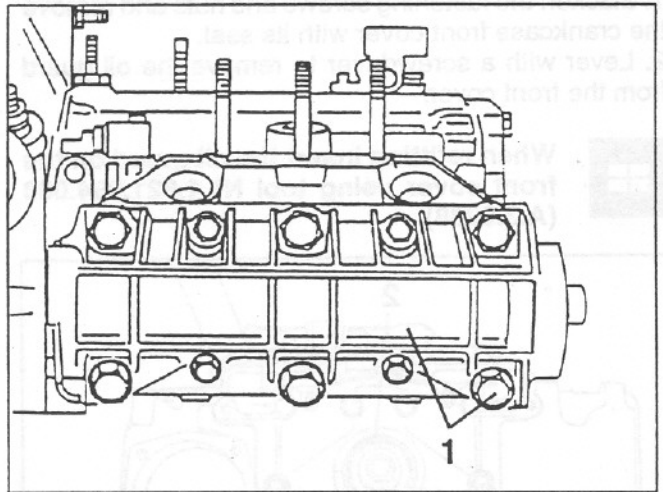

Removing the oil sump and pump

1. Slacken the fastening screws and remove the oil sump with its seal.

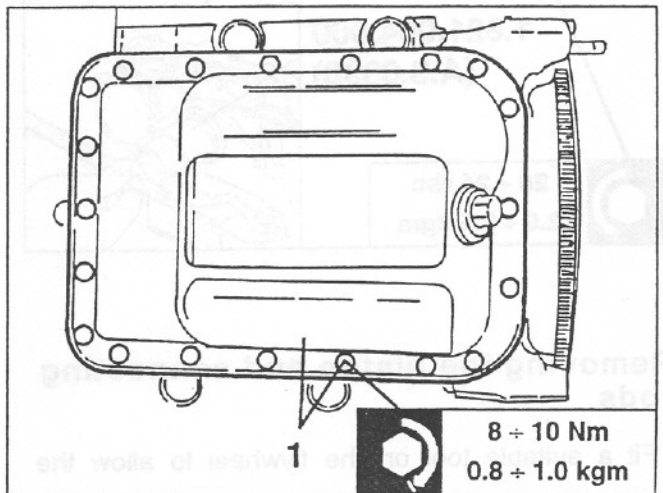



1. Slacken the screws fastening the oil pump to the crankcase rear cover and remove it.

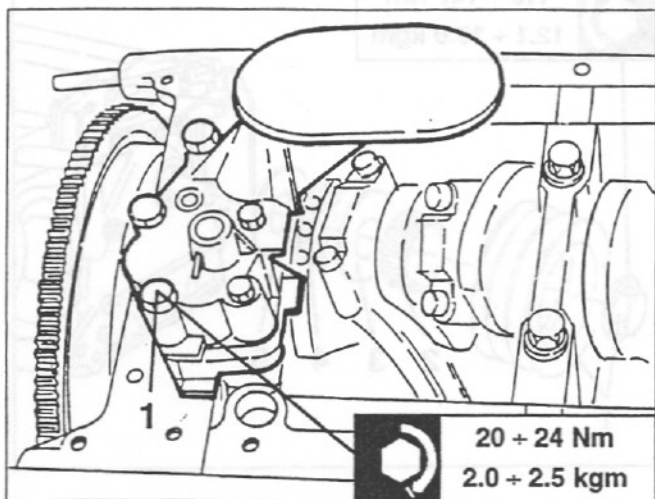

crankshaft to turn, then turn it to gain access to the connecting rod cap fastening screws.

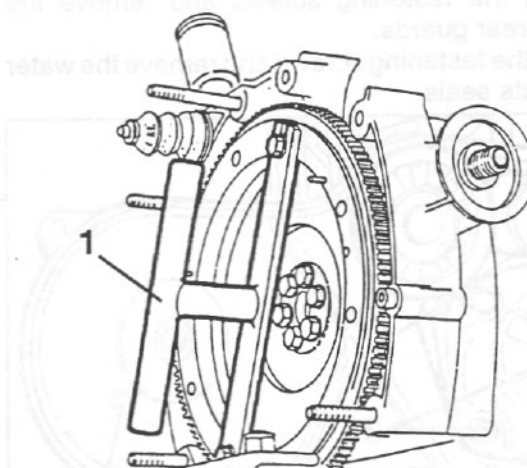

1. Slacken the fastening screws and remove the connecting rod caps with their half bearings.

Removing the crankcase front cover

1. Slacken the fastening screws and nuts and remove the crankcase front cover with its seal.
2. Lever with a screwdriver to remove the oil guard from the front cover.

 When refitting insert the oil guard on the front cover using tool N° 1.821.064.000 (A.3.0338).

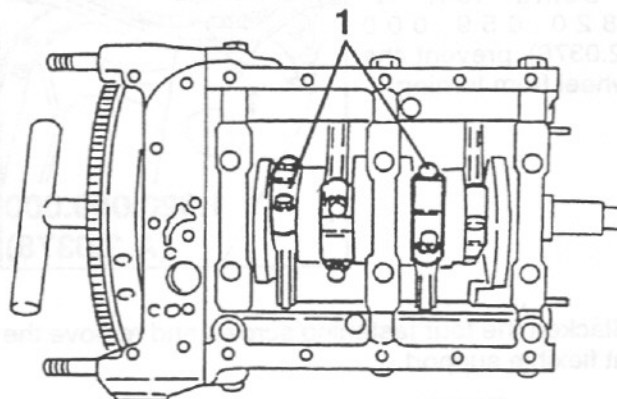
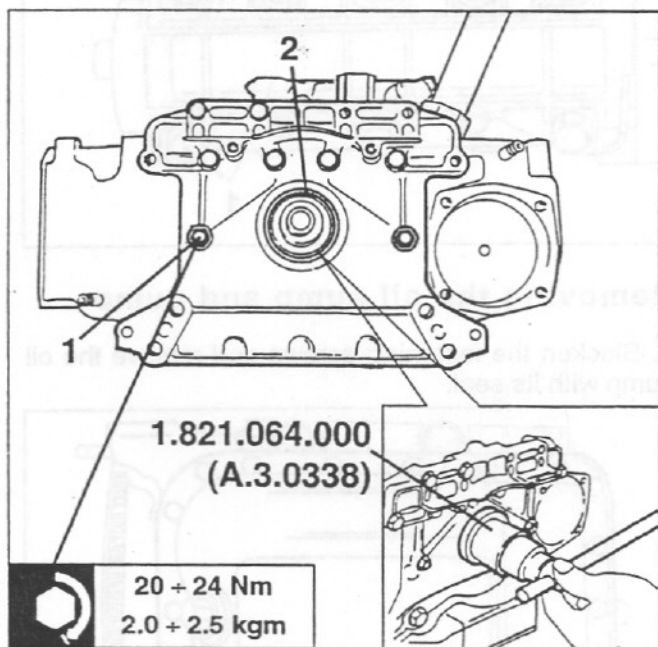

1. Remove the pistons from the crankcase complete with connecting rods and half bearings.

Removing the piston and connecting rods

- Fit a suitable tool on the flywheel to allow the

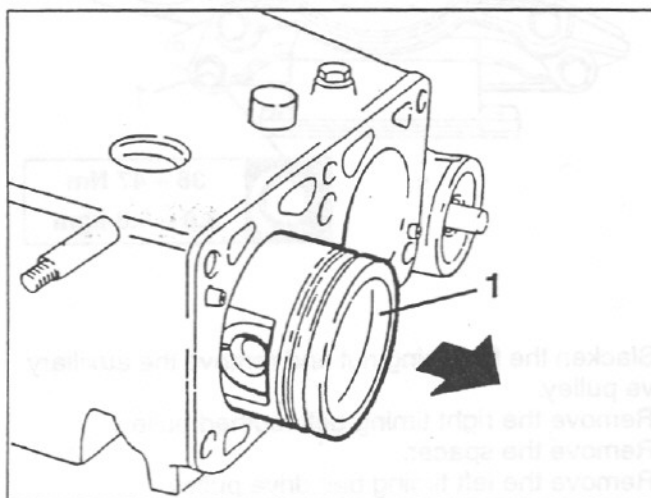

Remove the two gudgeon pin circlips.

2. Remove the gudgeon pin and separate the connecting rod from the piston.

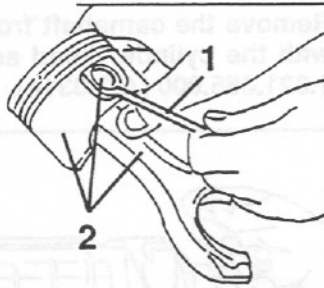

1. Using a suitable tool remove the seal rings and oil scraper ring from the piston.

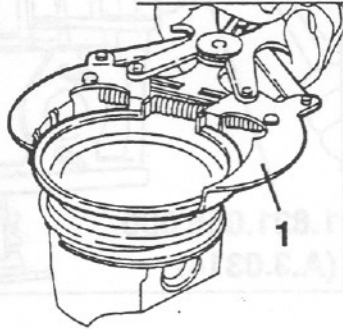

Work carefully to avoid breaking any rings that might be re-used.

Removing the flywheel

- Remove the tool for turning the crankshaft fitted previously and install tool N° 1.820.059.000 (A.2.0378) to prevent the flywheel from turning.

1. Slacken the fastening screws and remove the flywheel and safety plate.

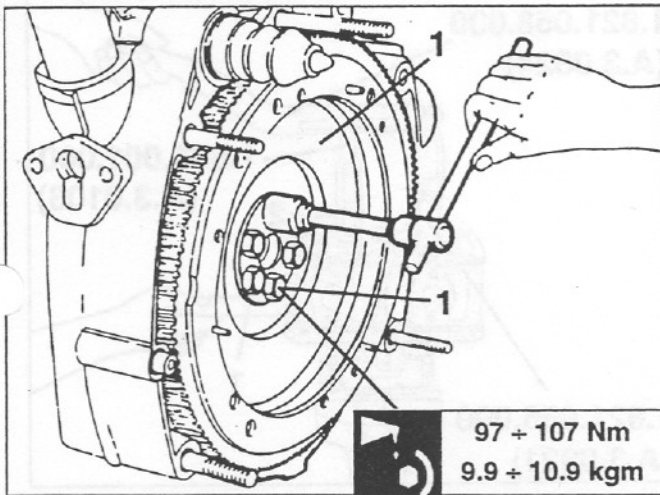

Removing the rear crankcase cover

1. Slacken the fastening screws and remove the rear crankcase cover and its seal.

2. Lever with a screwdriver to remove the oil guard from the rear cover.

Remove the seal ring from the main lubricating duct.

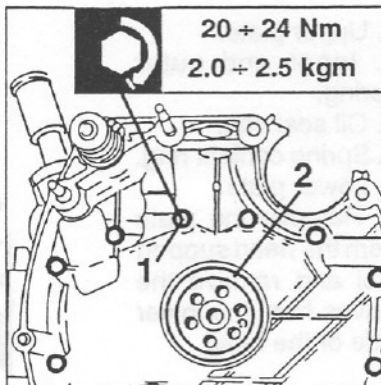

When refitting, use tool N° 1.821.063.000 (A.3.0337) to insert the oil seal ring on the rear cover.

Removing the crankshaft

1. Slacken the fastening screws and remove the main bearing caps with the corresponding bearing halves.

2. Remove the crankshaft from the crankcase and retrieve the half bearings and half thrust rings.

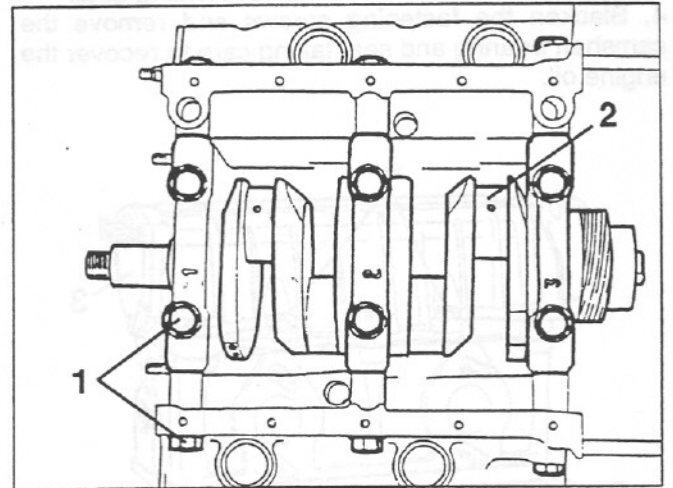

1. Fasten the crankshaft in a vice with protective jaws and using puller tool N° 1.821.087.000 (A.3.0402), remove the rear guide bush from the drive shaft.

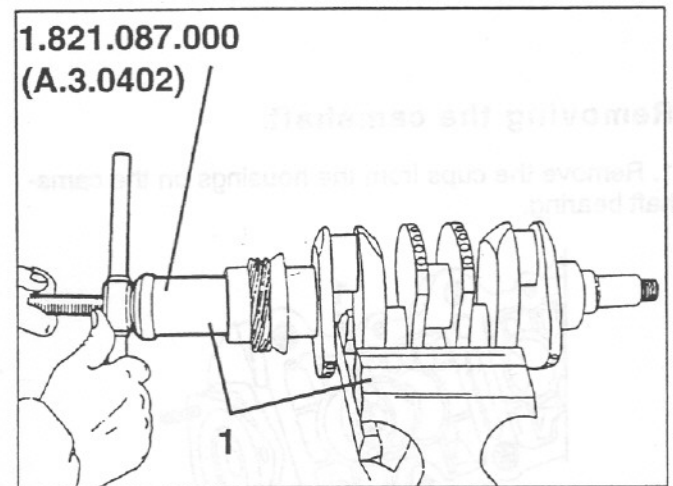

1. Working on the press using a suitable plate, remove the oil pump drive gear from the crankshaft.

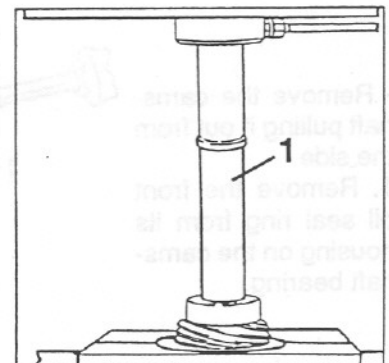

DIS-ASSEMBLY OF CYLINDER HEADS**Preliminary operations**

1. Clamp the swivelling stand N° 1.820.012.000 (A.2.0195) in a vice.
2. Fasten tool N° 1.820.016.000 (A.2.0226) on the swivelling stand and fasten the cylinder head onto it.
3. Slacken the fastening screws and remove the camshaft rear cover and the corresponding seal.
4. Slacken the fastening screws and remove the camshaft bearing and seal taking care to recover the engine oil.

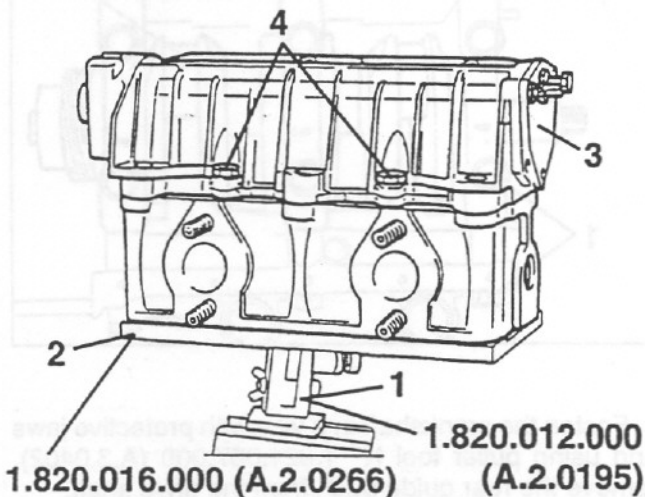
**Removing the camshaft**

1. Remove the cups from the housings on the camshaft bearing.

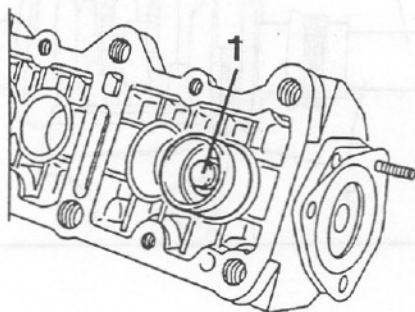

- Remove the camshaft pulling it out from the side.

1. Remove the front oil seal ring from its housing on the camshaft bearing.

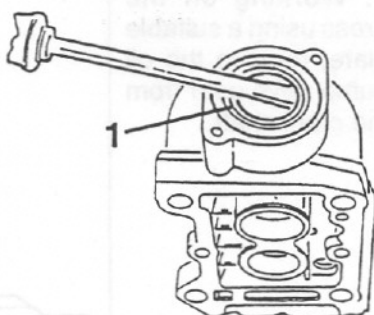

Remove the camshaft front oil seal ring working with the cylinder head assembled using tool N° 1.821.055.000 (A.3.0314).

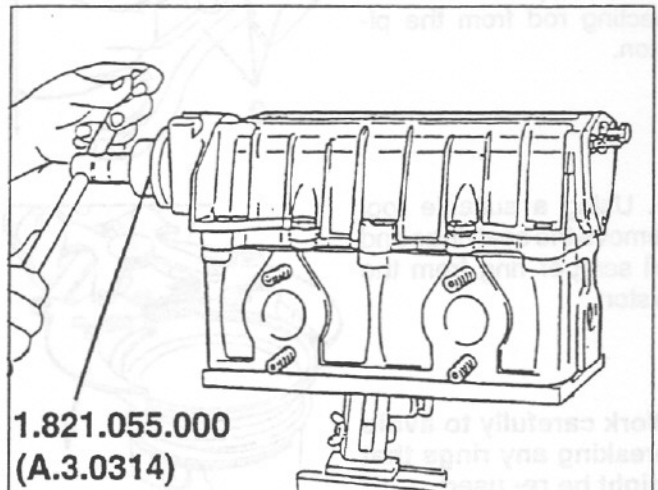
**Dis-assembly of valves**

1. Insert the valve seal plate in the head support tool.
2. Using tools N° 1.821.001.000 (A.3.0103), N° 1.821.058.000 (A.3.0324) and N° 1.821.056.000 (A.3.0321) remove the half tapers from the valve stem.

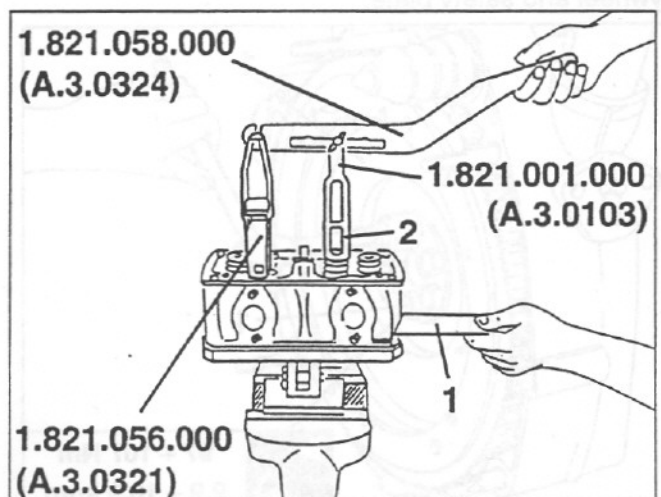

Remove:

1. Upper plate.
2. Inner and outer spring.
3. Oil seal cap.
4. Spring contact ring.
5. Lower plate.
6. Remove the plate from the head support tool and remove the valves from the lower side of the head.

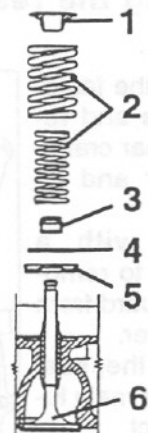



When refitting use tool N° 1.821.110.000 (A.3.0469) to insert the oil seal cap.

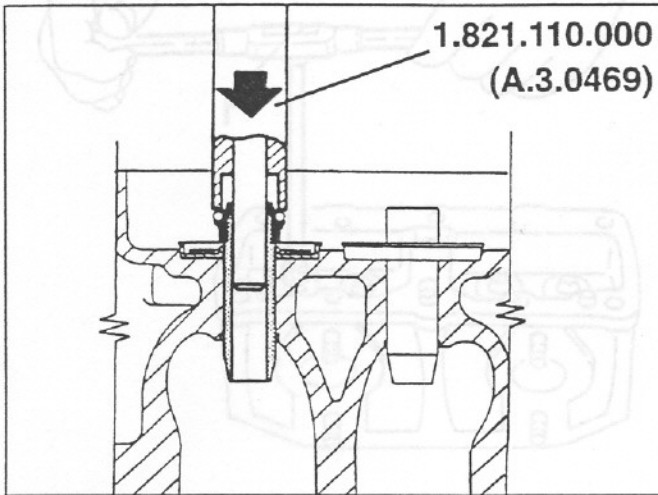

CHECKS AND INSPECTIONS CYLINDER HEADS

Checking the lower surface of cylinder heads

1. Check that the lower surface of the cylinder heads is level and check that it is within the specified limits.



Maximum head lower plane flatness
0.03 mm

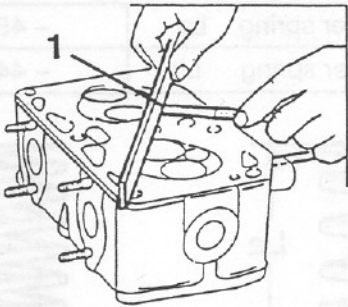

- If the lower surface of the head is excessively distorted, both heads should be refaced without exceeding the minimum allowed value.



Minimum height of cylinder heads after refacing
77.676 ÷ 77.750 mm



CAUTION:
Exceeding the allowed height limit after refacing involves serious engine operating failures.

Checking the clearance between valve guides and valve stems

1. Measure the diameter of the valve stems and check that it is within the specified limits.



Diameter of valve stems	
Intake	7.985 ÷ 8.000
Exhaust	7.968 ÷ 7.983

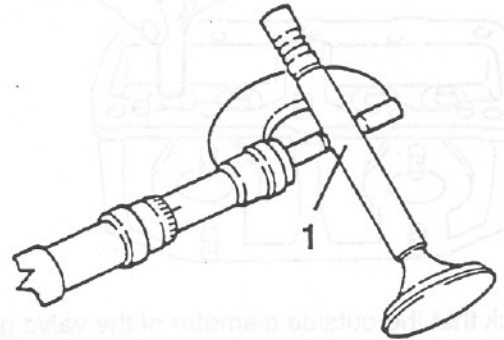

1. Measure the inside diameter of the valve guides and check that it is within the specified limits.



Inside diameter of valve guide
8.013 ÷ 8.031 mm

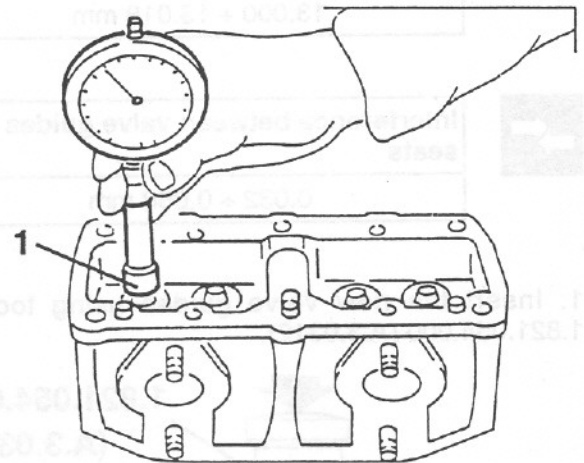

- Calculate the clearance between valve guides and stems and check that it is within the specified limit, if not, change any worn parts.



Radial clearance between valve guides and stems	
Intake	0.013 ÷ 0.046
Exhaust	0.030 ÷ 0.063



Changing the valve guides

1. Using puller tool N° 1.821.053.000 (A.3.0311), remove the worn valve guides.

1.821.053.000
(A.3.0311)

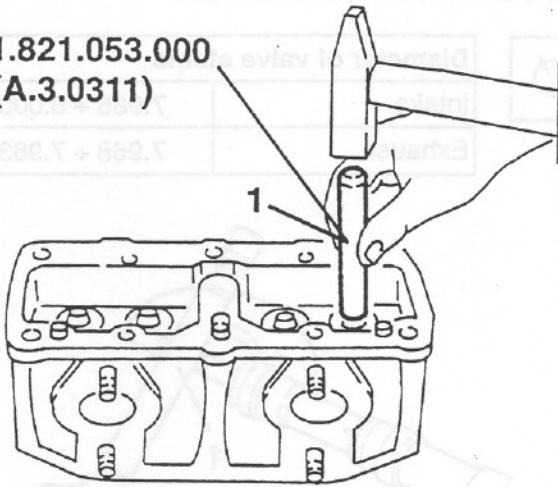

- Check that the outside diameter of the valve guides and their seats on the head are within the specified limits and that their assembly interference is correct.

∅	Outside diameter of valve guides
	13.050 ÷ 13.068 mm

∅	Diameter of valve guide seats
	13.000 ÷ 13.018 mm

↔	Interference between valve guides and seats
	0.032 ÷ 0.068 mm

1. Insert the new valve guides using tool N° 1.821.054.000 (A.3.0312).

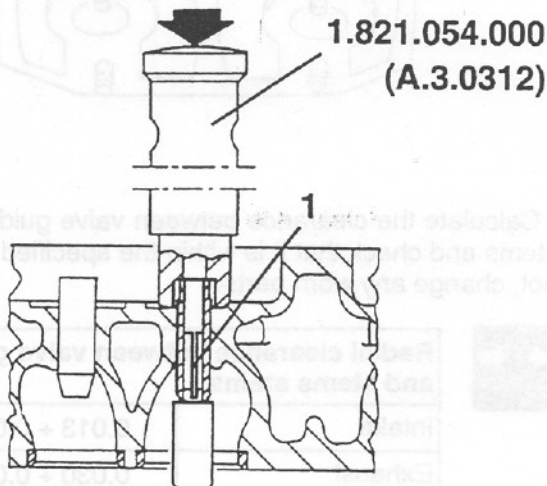

1. Bore the valve guide inside diameter using the reamer to calibrate the holes to the specified diameter.

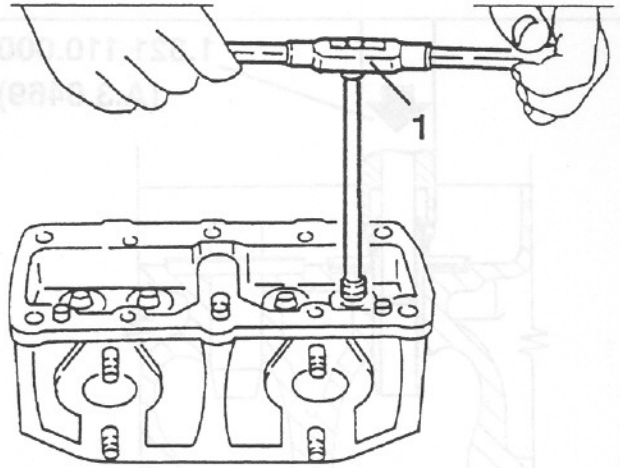

∅	Inside diameter of valve guides
	8.013 ÷ 8.031 mm

Checking the valve springs

- Check that the "free" length of the valve springs is within the specified limits.

NOTE: The rest surfaces must be parallel with each other and perpendicular to the axis of the spring with a maximum error of 2°.

	Length of valve springs	
	outer spring La	~ 45 mm
	inner spring Lb	~ 44 mm

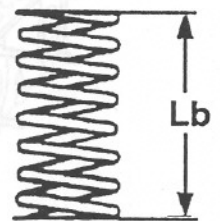
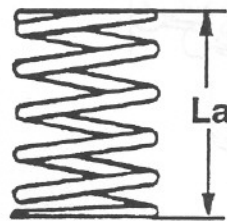

- Using a torque meter, check that the characteristic data of the springs are within the specified limits.

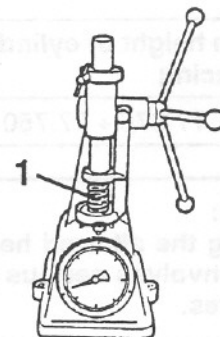

Outer spring length (mm)		Control load (kg)
Valve closed	32.2	23.0 + 24.4
Valve open	23.2	43.3 + 46.1

Length of inner spring (mm)		Control load (kg)
Valve closed	30.2	11.6 + 12.4
Valve open	21.2	20.4 + 21.8

Turning the valve seats

1. Turn the valve seats using suitable tools with the cylinder heads cold



Taper of contact area with valve "β"	90° + 90°30'
Taper of upper valve seat area "α"	120°
Taper of lower valve seat area "γ"	Int. 70°
	Exh. 30°



Dimension "a" at refacing limit	2.9 mm
Height "b" valve contact area	Int. 1.07 + 1.37 mm
	Exh. 1.26 + 1.56 mm



Reference diameter \varnothing_R	
Intake	39.0 mm
Exhaust	31.9 mm

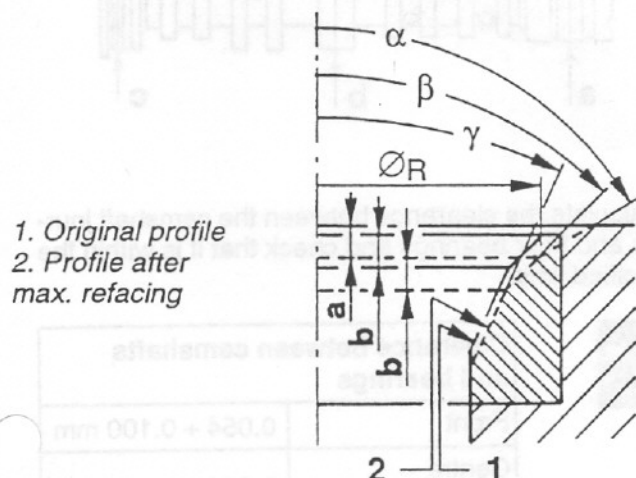

- After machining grind each valve in its housing as follows:

- coat the contact surfaces "A" and "B" of the valves and seats with abrasive paste (SIPAL AREXONS Carborasilicium for valves).
- lubricate the valve stem with engine oil.
- fit the lower surface of the valve mushroom to the suction cup "C" of a pneumatic grinder.
- insert the valve in its guide and grind.
- after grinding, thoroughly clean the valve and the seat.

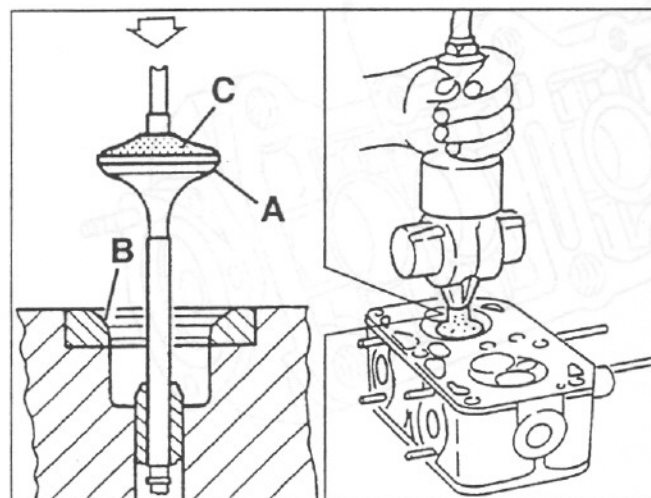

- When changing the valve guides, thus refacing and grinding the valve seats, it is advisable to check the valve tightness with the spark plugs in place, proceeding as follows:

1. Fill the hollow of the combustion chamber with petrol.
 2. Admit low pressure air to the intake manifolds and check that no air bubbles form in the petrol.
- Check the tightness of the exhaust valves in the same way, admitting air to the exhaust manifolds.
- If any leaks are noted, make sure that the valves are perfectly settled in their seats and repeat the check; if the result is negative, grinding must be repeated.

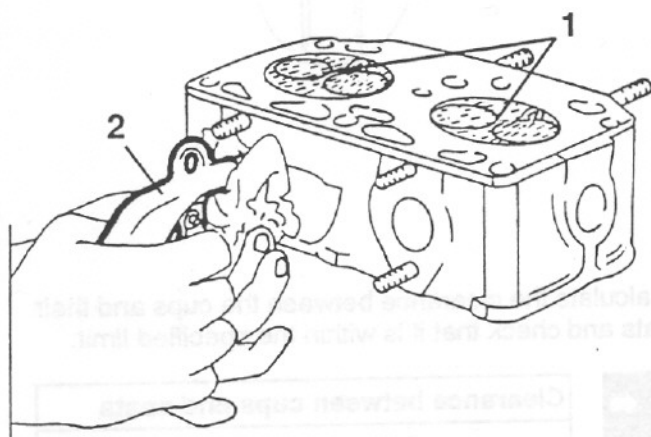

Checking the clearance between cups and seats

1. Check that the diameter of the seats is within the specified limits.

∅	Diameter of valve cup seats
	35.000 ± 35.025 mm

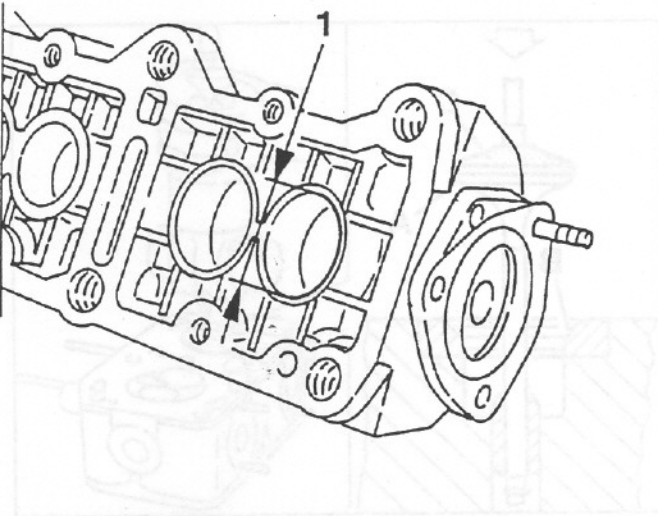

1. Check that the outside diameter of the cups is within the specified limits.

∅	Diameter of valve cups
	34.959 ± 34.975 mm

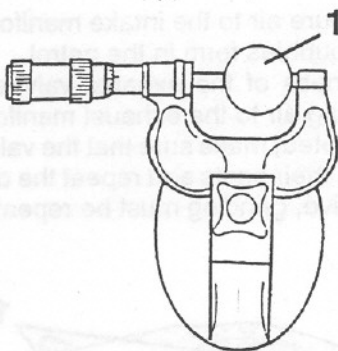

- Calculate the clearance between the cups and their seats and check that it is within the specified limit.

↕	Clearance between cups and seats
	0.025 ± 0.066 mm

Camshafts and timing system bearings

1. Check that the diameter of the camshaft supports is within the specified limits.

∅	Diameter of camshaft supports	
	Front	35.015 ± 35.040 mm
	Centre	48.000 ± 48.025 mm
	Rear	49.200 ± 49.225 mm

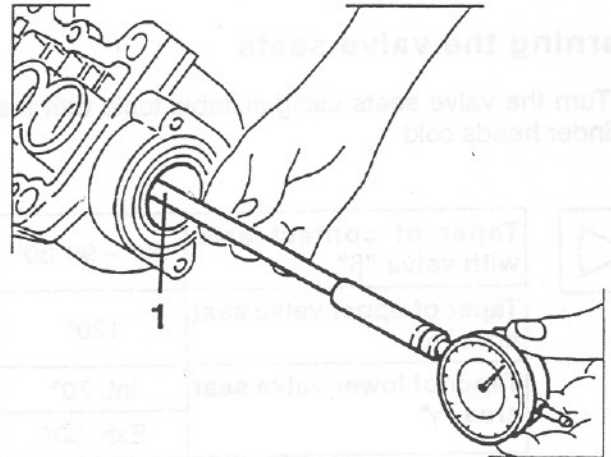

1. Check that the diameter of the camshaft journals is within the specified limits.

∅	Diameter of camshaft journals	
	Front "a"	34.940 ± 34.961 mm
	Centre "b"	47.940 ± 47.956 mm
	Rear "c"	49.140 ± 49.156 mm

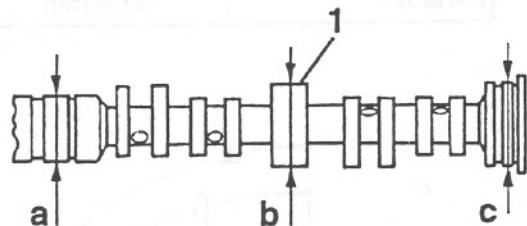

- Calculate the clearance between the camshaft journals and their bearings and check that it is within the specified limit.

↕	Clearance between camshafts and bearings	
	Front	0.054 ± 0.100 mm
	Centre - Rear	0.044 ± 0.085 mm



Check that the cam lifts exceed the minimum permissible limit.

Minimum cam lift	
Intake	9.8 mm (*)
Exhaust	9.0 mm

(*): 9.0 mm for 1351 c.c. engines after change and 1596 c.c. Rochester engine.

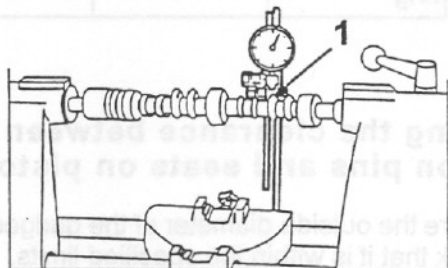

HECKING AND INSPECTING THE CRANKCASE

- Visually inspect the crankcase for cracks and signs of excessive wear on the sliding surfaces; check that all the threads are intact.
- Remove the plugs of the lubrication and cooling ducts and clean the ducts with a suitable detergent, then dry them with a jet of air and refit new plugs.
- Accurately clean the crankcase surfaces of any fragments of seals or sealants.

Checking cylinders

- Using a bore gauge on a dial gauge, measure the inside diameter of the cylinders and check that it is within the specified limits.

∅	Inside diameter "d" (mm)		
	Engine	AR 33501	AR 33201
Class A (Blue)	80.000 ÷ 80.010	84.000 ÷ 84.010	
Class B (Pink)	80.010 ÷ 80.020	84.010 ÷ 84.020	
Class C (Green)	80.020 ÷ 80.030	84.020 ÷ 84.030	
Class D (Yellow)	80.030 ÷ 80.040	84.030 ÷ 84.040	
Class E (White)	80.040 ÷ 80.050	84.040 ÷ 84.050	

△	Maximum taper
	A - B = 0.02 mm

○	Maximum ovalisation
	X - Y = 0.02 mm

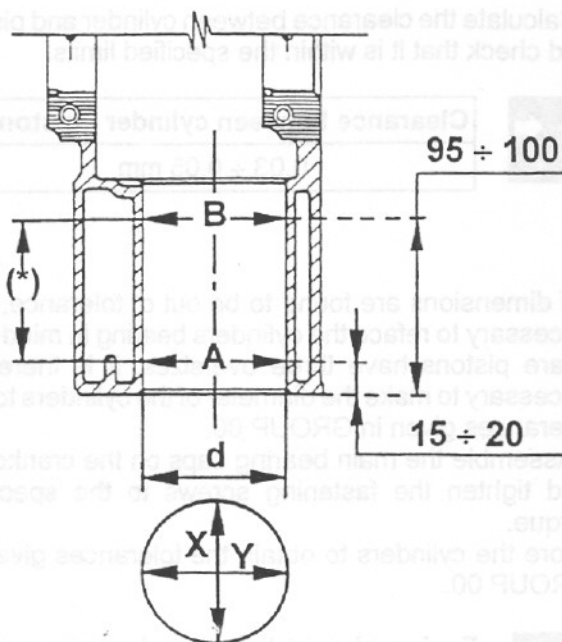

(*) Area for dimensional control

Checking pistons

1. Measure the outside diameter of the pistons and check that it is within the specified limits.

∅	Piston outside diameter (mm) (1)		
	Engine	AR 33501	AR 33201
Class A (Blue)	79.960 ÷ 79.970	83.950 ÷ 83.960	
Class B (Pink)	79.970 ÷ 79.980	83.960 ÷ 83.970	
Class C (Green)	79.980 ÷ 79.990	83.970 ÷ 83.980	
Class D (Yellow)	79.990 ÷ 80.000	83.980 ÷ 83.990	
Class E (White)	80.000 ÷ 80.010	83.990 ÷ 84.000	

(1) To be measured at right angles to the gudgeon pin hole at a distance of 14 mm from the lower edge of the skirt for "Borgo" pistons and 11.5 mm from the gudgeon pin axis for "Mondial" pistons.

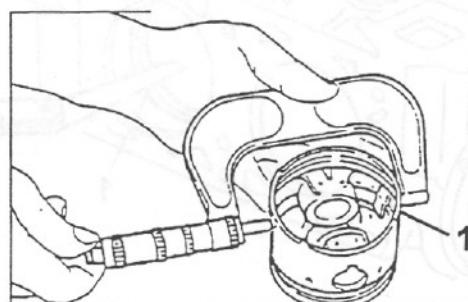



- Calculate the clearance between cylinder and piston and check that it is within the specified limits.



Clearance between cylinder - piston

0.03 ÷ 0.05 mm

- If dimensions are found to be out of tolerance, it is necessary to reface the cylinders bearing in mind that spare pistons have three oversizes; it is therefore necessary to make the diameter of the cylinders to the tolerances given in GROUP 00.

- Assemble the main bearing caps on the crankcase and tighten the fastening screws to the specified torque.

- Bore the cylinders to obtain the tolerances given in GROUP 00.



Facing should be carried out in such a way that the machining signs are crossed by an angle of 90° ÷ 120°.

1. Check that the difference in weight between pistons complete with gudgeon pins and seal rings is within the specified limit.

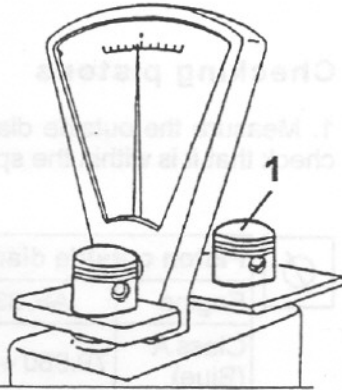

Difference in weight between pistons

≤ 2 g

Checking seal ring gap

1. Insert the seal rings in the cylinder liner, check that they adhere to the whole circumference and check that the gap is within the specified limits.

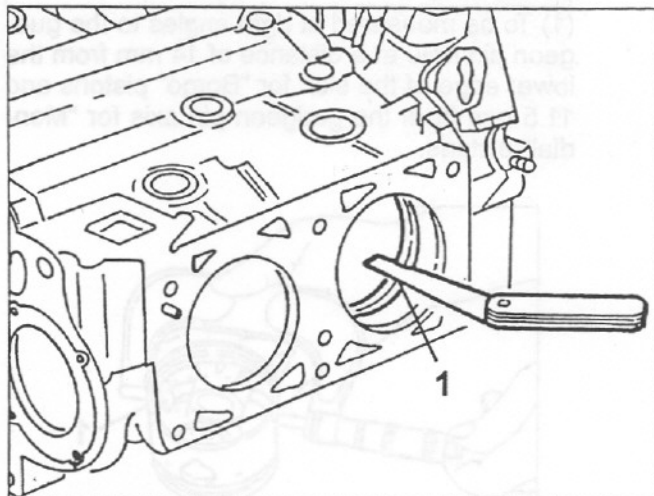

Ring gap (mm)

Engine	AR 33501	AR 33201
First ring	0.30 ÷ 0.45	0.30 ÷ 0.50
Second ring	0.30 ÷ 0.45	0.30 ÷ 0.50
Oil scraper ring	0.25 ÷ 0.40	0.25 ÷ 0.40

Checking the clearance between gudgeon pins and seats on pistons

1. Measure the outside diameter of the gudgeon pins and check that it is within the specified limits.



Gudgeon pin outside diameter

20.996 ÷ 21.000 mm

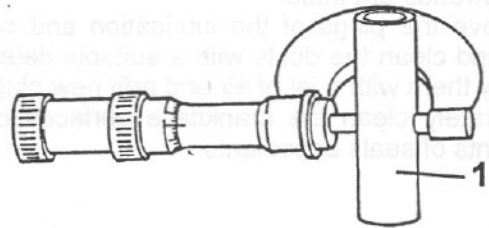

1. Measure the diameter of the hole on the piston corresponding to the gudgeon pins and check that it is within the specified limits.



Gudgeon pin hole diameter in pistons

21.004 ÷ 21.008 mm

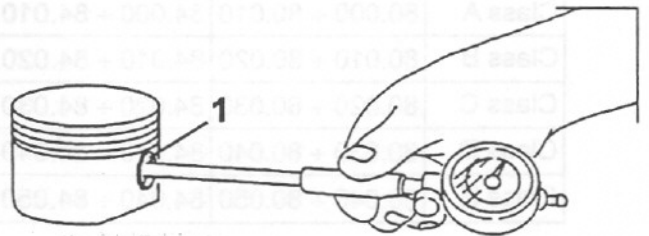

- Calculate the clearance between the gudgeon pins and their seats on the pistons and check that it is within the specified limits.



Clearance between gudgeon pins and seats on pistons

0.004 ÷ 0.012 mm

Checking the clearance between connecting rod journals and the corresponding half bearings

1. House the rod half bearings in the connecting rod big end and on the corresponding cap, then join them together by tightening the fastening screws to the specified torque.
2. Measure the diameter of the connecting rod big end and check that it is within the specified limits.

∅	Inside diameter of connecting rod half bearings	
	Class A - Blue	50.024 + 50.048 mm
	Class B - Red	50.032 + 50.056 mm

 **53 + 58 Nm**
5.4 + 5.9 kgm

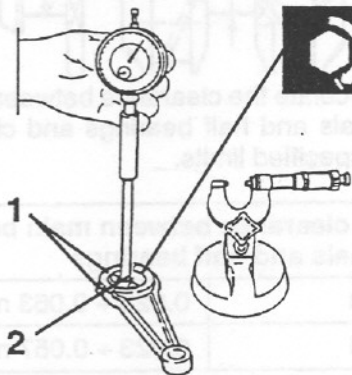

1. Measure the diameter of the connecting rod journals and check that it is within the specified limits.

∅	Diameter of connecting rod journals	
	Class A - Red	49.992 + 50.000 mm
	Class B - Blue	49.984 + 49.992 mm

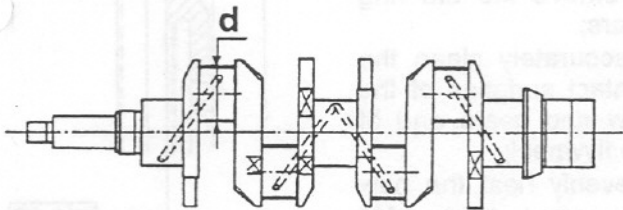

Due to the nitriding treatment the crankshaft has been subjected to, no grinding operations are possible; therefore it must be changed in the event of excessive wear.

- Calculate the clearance between the rod journals and half bearings and check that it is within the specified limits.

	Clearance between rod journals and half bearings	
	0.032 + 0.064 mm	

Checking the connecting rods

1. Check that the difference in weight between the rods complete with half bearings, caps and screws is within the specified limit.

	Difference in weight between connecting rods	
	≤ 2 g	

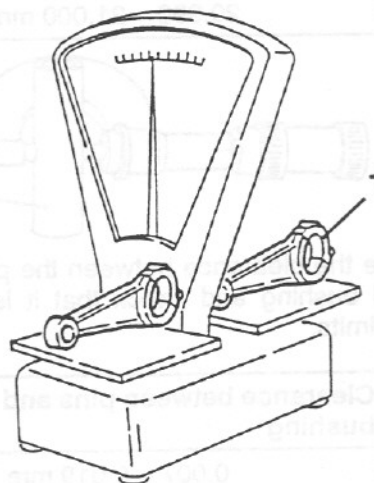

1. Check that the rods are perpendicular using a reference plane as illustrated.

If perpendicularity is not perfect, the connecting rod must be changed to avoid abnormal stresses when the engine is running, resulting in uneven wear of the piston and of the rod itself.

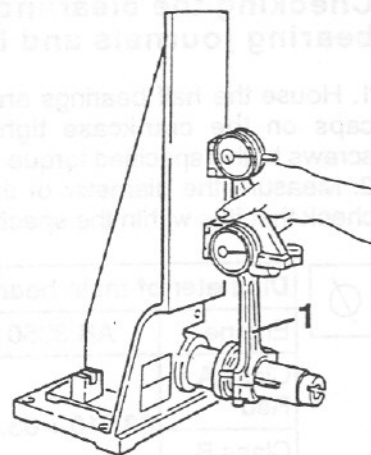

Checking the clearance between pins and small end bushings

1. Measure the inside diameter of the small end bushing and check that it is within the specified limits, if not, change the bushing.





Inside diameter of small end bushing

21.007 + 21.015 mm

1. Measure the outside diameter of the pins and check that it is within the specified limits.



Outside diameter of pins

20.996 + 21.000 mm

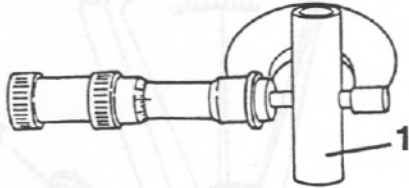

- Calculate the clearance between the pins and the small end bushing and check that it is within the specified limits.



Clearance between pins and small end bushing

0.007 + 0.019 mm

Checking the clearance between main bearing journals and half bearings

1. House the half bearings and fit the main bearing caps on the crankcase tightening the fastening screws to the specified torque.
2. Measure the diameter of the main bearings and check that it is within the specified limits.



Diameter of main bearings (mm)

Engine	AR 33501	AR 33201
Class A Red	63.610 + 63.635	63.618 + 63.640
Class B Blue		63.616 + 63.638

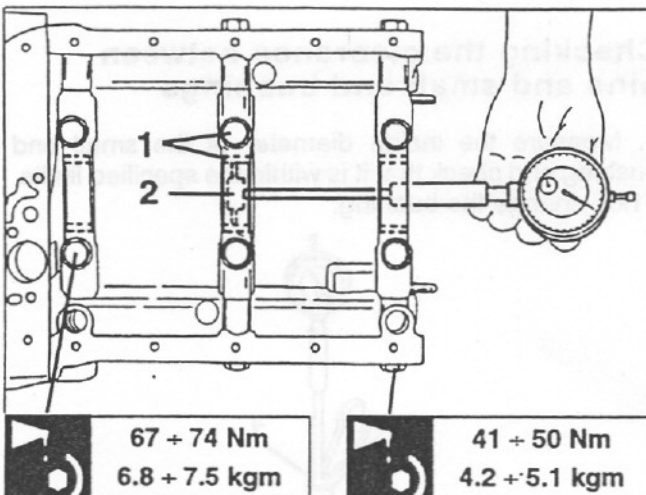

1. Measure the diameter of the main bearing journal and check that it is within the specified limits.



Diameter of main bearing journals (mm)

Engine	AR 33501	AR 33201
Class A Red	59.944 + 59.957	59.954 + 59.964
Class B Blue		59.944 + 59.954

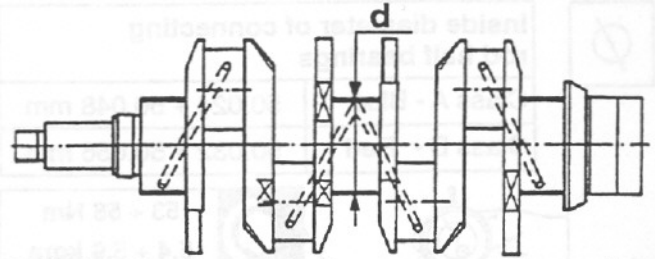

- Calculate the clearance between the main bearing journals and half bearings and check that it is within the specified limits.



Working clearance between main bearing journals and half bearings

AR 33501	0.028 + 0.063 mm
AR 33201	0.023 + 0.057 mm

Checking the engine flywheel

- Check that the ring gear teeth are not cracked or show signs of seizure; if they do, proceed as follows to change them:

- remove the old ring gears;
- accurately clean the contact surfaces of the new ring gears and of the flywheel;
- evenly heat the new ring gears to 120° + 140° C and fit them on the flywheel;
- leave to cool naturally, do not force cool.

- Check that the surface of the flywheel on which the clutch driven plate works has no nicks, material removal or signs of overheating. If not, check that dimension "B" shown in the diagram is above the specified limit and that the machining allowance enables refacing.

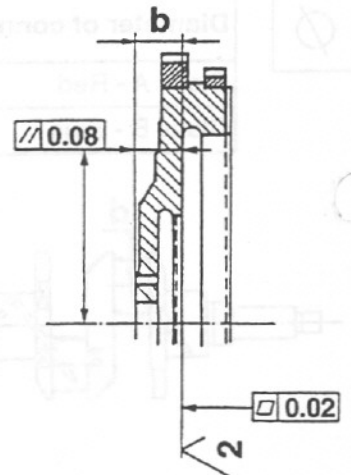

Refacing dimension

B ≥ 21.15

AUTIONS FOR RE-ASSEMBLY

For re-assembly operations reverse the sequence of those described for dis-assembly unless otherwise indicated below.

- Check valve tightness when the cylinder heads are assembled.

Reassembling the crankshaft

1. If removed previously, the crankshaft rear bushing should be refitted using tool n° 1.821.104.000 (A.3.0450).
2. Heat the oil pump drive gear to 150°C and shrink it onto the crankshaft directing it as illustrated.

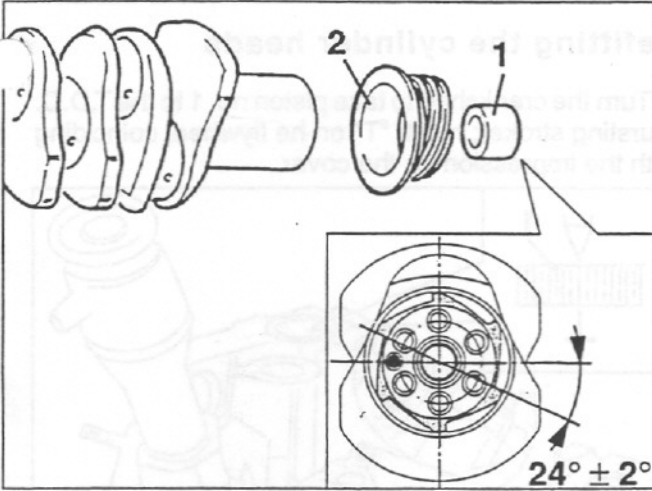
**Tightening the main bearing caps**

- Assemble the main bearing caps on the crankcase bearings in the correct position and tighten the fastening screws in oil without locking them.

1. Tighten the main bearing cap fastening screws to the respective crankcase bearings two or three times in the sequence shown from A to F.
2. Then in two or three operations, tighten the screws fastening the main bearing caps to the crankcase in the sequence shown from G to N.

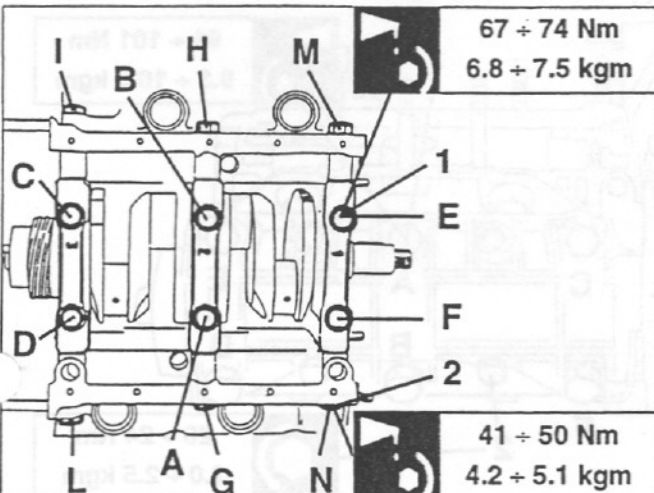

- Turn the crankshaft by hand and check that it turns smoothly.

Checking the crankshaft end float

1. Using a dial gauge on a magnetic base, measure the crankshaft end float and check that it is within the specified limits.

**Crankshaft end float**

0.06 ÷ 0.25 mm

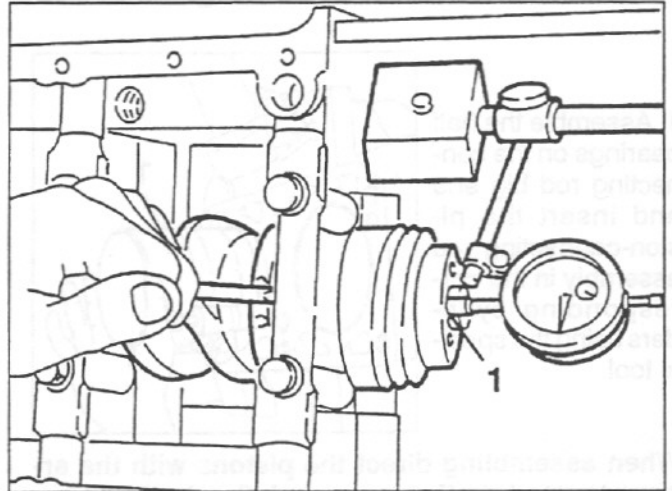
**Refitting the pistons and connecting rods**

1. Assemble the pistons and connecting rods so that the pistons of the right cylinder head 1-3 have the arrow stamped on the crown pointing upwards and the pistons of the left head 2-4 have the arrow pointing downwards.

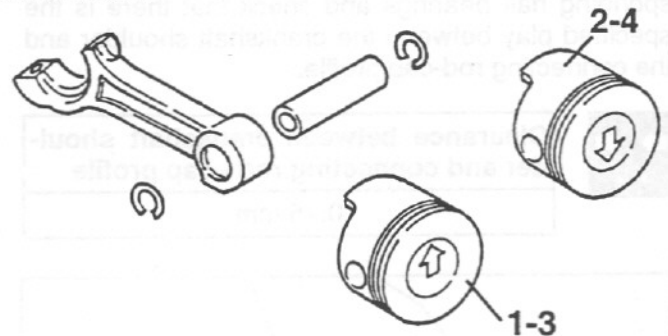

1. Insert the rings on the piston making sure that the wording on the flat surface faces upwards.

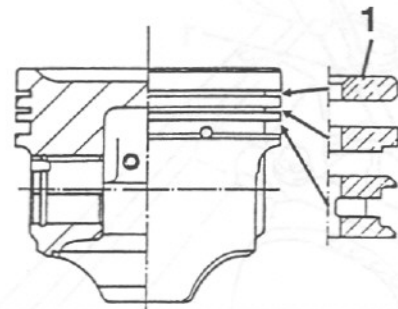

- Direct the rings on the pistons with the cuts offset by 120°.

P1. Position of upper ring;
P2. Position of lower ring;
P3. Position of oil scraper ring;
aa. Gudgeon pin axis;
dd. Direction of thrust;

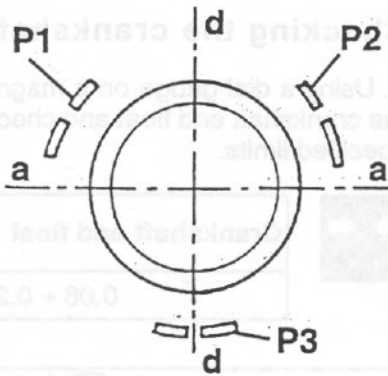

1. Assemble the half bearings on the connecting rod big end and insert the piston-connecting rod assembly in the corresponding cylinders using the special tool.

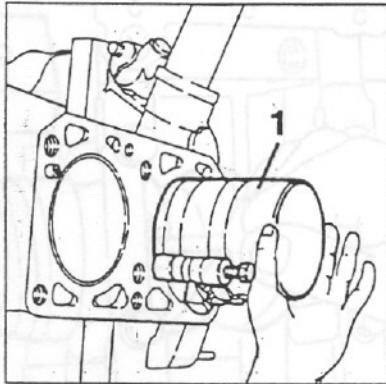

When assembling direct the pistons with the arrow stamped on the crown pointing in the direction of rotation of the engine, i.e. upwards for the right head pistons and downwards for the left head pistons.

The position of the connecting rod big end must make it possible to read the identification number.

1. Position the connecting rod caps with the corresponding half bearings and check that there is the specified play between the crankshaft shoulder and the connecting rod-cap profile.



Clearance between crankshaft shoulder and connecting rod - cap profile

0.15 mm

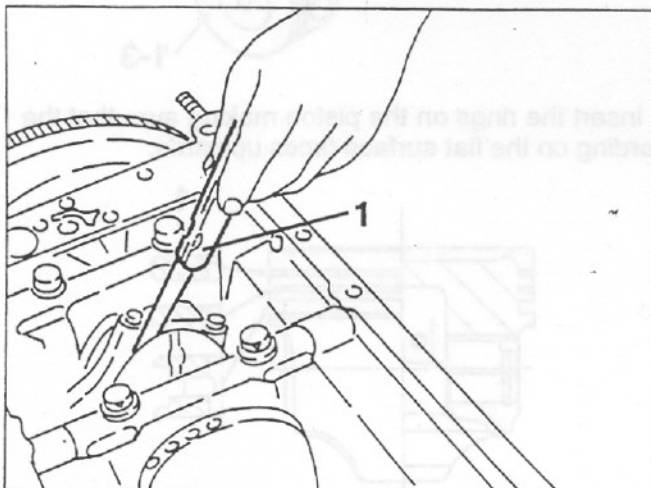

1. Suitably turn the crankshaft to tighten the connecting rod cap fastening screws.

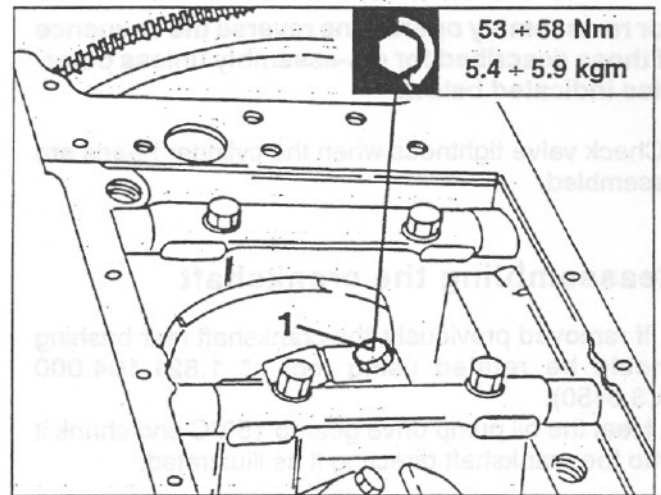

Refitting the cylinder heads

1. Turn the crankshaft to take piston no. 1 to the T.D.C. (bursting stroke); notch "T" on he flywheel coinciding with the impression on the cover.

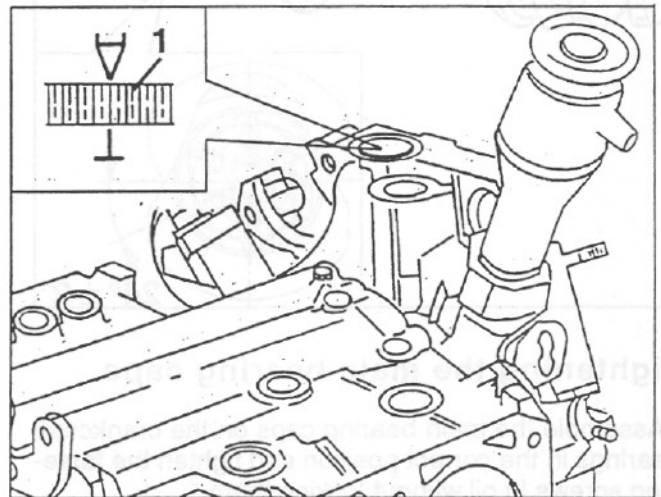

1. Assemble the cylinder heads on the crankcase with the seals interposed and tighten the screws in to or three operations following the sequence illustrated (A - F).

2. Tighten the four screws fastening the camshaft support in crossed order.

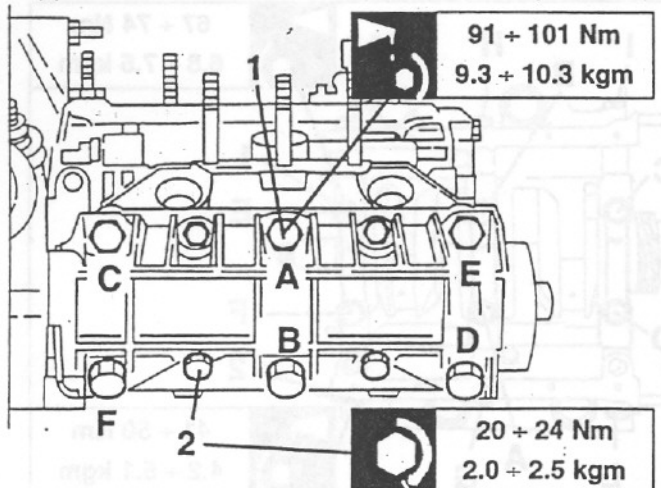



When working with the engine assembled on the car, use the extension wrench N° 1.822.010.000 (A.5.0198), the tightening torques become:

	for torque wrench with 300 mm arm	64 + 71 Nm 6.5 + 7.2 kgm
	for torque wrench with 400 mm arm	69 + 77 Nm 7.0 + 7.8 kgm

Assembling the timing belts

1. Turn the left camshaft so that the tooth and the two adjacent grooves milled on the timing pulley can be seen through the special holes on the rear guard.
- Turn the crankshaft until the notch "T" on the flywheel is aligned with the fixed reference on the rear cover.

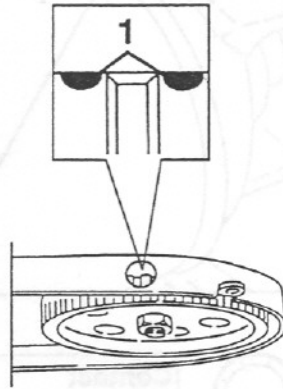

1. Fit the left timing belt.
2. Slacken the belt tensioner fastening nut so that it can exert the load impressed by the spring on the belt, then tighten the nut.

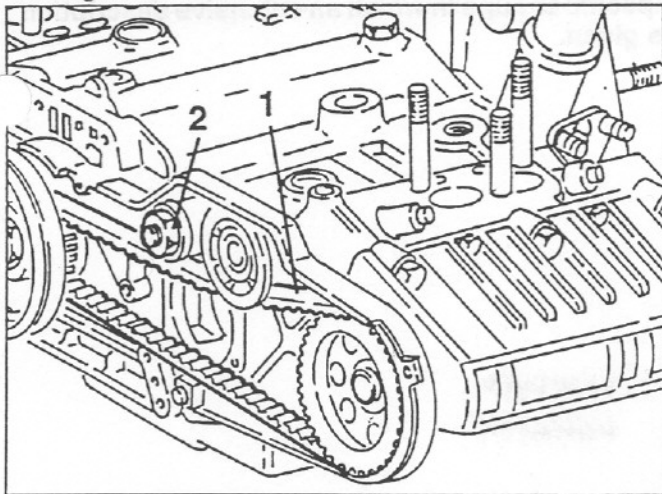

CAUTION:
The belt should be keyed with the belt pulling branch opposite the tensioners taut.

1. Turn the right camshaft so that the tooth and the two adjacent grooves milled on the timing pulley can be seen through the special holes on the rear guard.
- Turn the crankshaft until the notch "T" on the flywheel is aligned with the fixed reference on the rear cover.

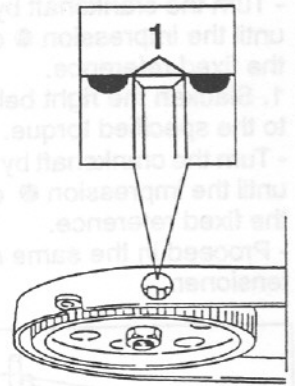

1. Fit the right timing belt.
2. Slacken the belt tensioner fastening nut so that it can exert the load impressed by the spring on the belt, then tighten the nut.

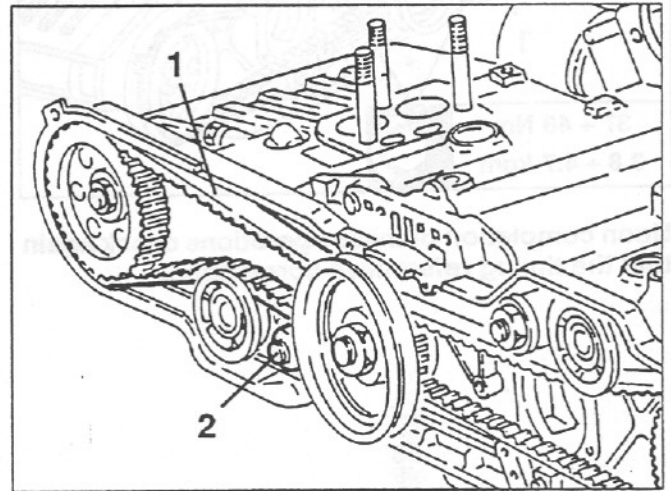

CAUTION:
Use special wrench N° 1.822.008.000 (A.5.0195) to prevent the pulley from turning.

- Turn the crankshaft a few times in its direction of rotation to allow the belts to take their final position.
- 1. Check the engine timing.

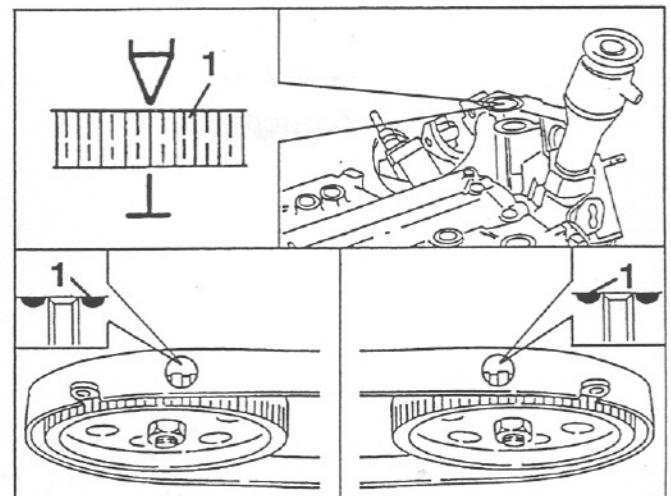



- Turn the crankshaft by 90° in its direction of rotation until the impression ● on the flywheel is aligned with the fixed reference.

1. Slacken the right belt tensioner nut, then tighten it to the specified torque.

- Turn the crankshaft by 360° in its direction of rotation until the impression ● on the flywheel is aligned with the fixed reference.

- Proceed in the same manner to tighten the left belt tensioner.

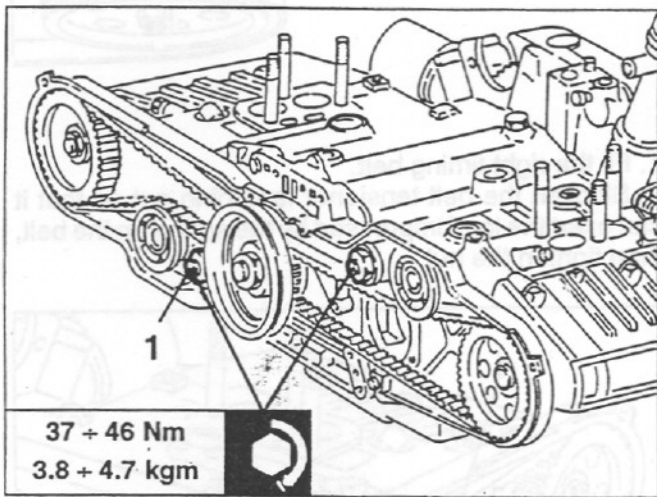

Upon completion of these operations check again that the timing references correspond.

CHECKING THE ELECTRICAL COMPONENTS OF THE LUBRICATION CIRCUIT

Minimum engine oil pressure warning light sensor

1. Check the setting of the minimum engine oil pressure warning light sensor. If the value fails to meet specifications, change the sensor.

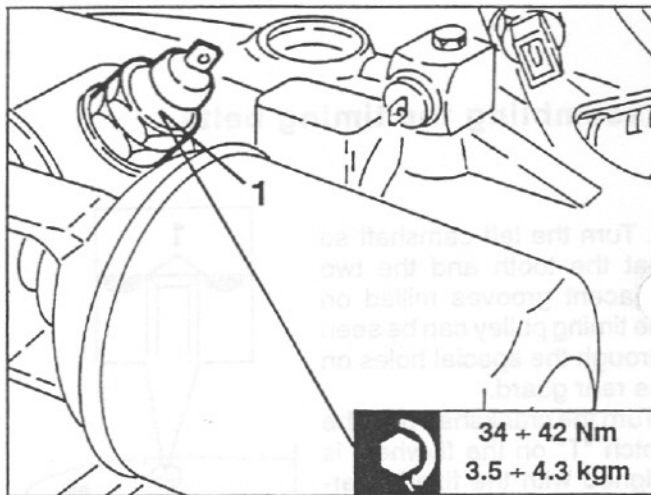

Contact opening/closing pressure

0.2 + 0.5 bar

For the other sensors and electrical components located in the engine compartment, refer to the specific Groups in which an extensive description is given.