

Repair Manual Audi TT 2007 ➤

Maintenance Procedures

Edition 08.2011

List of Workshop Manual Repair GroupsList of Workshop Manual Repair GroupsList of Workshop Manual Repair Groups

Repair Group

03 - Maintenance, Diagnosis

Technical information should always be available to the foremen and mechanics, because their careful and constant adherence to the instructions is essential to ensure vehicle road-worthiness and safety. In addition, the normal basic safety precautions for working on motor vehicles must, as a matter of course, be observed.

Contents

03 - Maintenance, Diagnosis	1
1 General Information	1
1.1 Engine Overview	1
1.2 Type Plate and VIN	4
1.3 Raising Vehicle	6
1.4 Tow Starting/Towing	7
1.5 Vehicle Checks during Inspection and Maintenance	9
2 Maintenance Procedures	12
2.1 Strut Tube Cap, Lubricating	13
2.2 Measured Values Block 32, Reading	14
2.3 Battery, Checking Level Using Guided Fault Finding	14
2.4 Battery, Checking No Load Voltage before Starting Engine	15
2.5 Battery, Check Fluid Level	17
2.6 AGM Battery, Checking	19
2.7 Battery, Checking Cables for Secure Seating	20
2.8 Tires, Checking	20
2.9 Brake System, Inspecting for Leaks and Damage	22
2.10 Brake Pads, Checking Thickness	22
2.11 Brake Fluid, Checking Depending on Brake Pad Wear	23
2.12 Brake Fluid, Changing	24
2.13 Fuel Injector Cleaner G17	27
2.14 Key, Check Functionality	28
2.15 DTC Memory, Checking	28
2.16 Engine Compartment Front Noise Insulation Cover, Removing and Installing	28
2.17 Coolant System, Checking	29
2.18 Instrument Cluster, Selecting Language	30
2.19 Air Filter, Cleaning Housing and Removing and Installing Filter	31
2.20 Haldex Clutch Oil, Changing	37
2.21 Hood Safety Catch, Lubricating	37
2.22 Engine Cover, Removing	37
2.23 Engine and Engine Compartment from Underneath, Inspecting for Leaks and Damage ..	39
2.24 Engine Oil, Draining/Extracting and Removing and Installing Filter	40
2.25 Hood Hinge, Lubricating	43
2.26 Engine Oil, Filling	43
2.27 Engine Oil Level, Checking	44
2.28 Navigation Eject Button, Unlocking	44
2.29 Radio, Entering Security Code to Activate Anti-Theft Coding	44
2.30 Road Test	45
2.31 Wheel Bolts, Tightening Specifications	46
2.32 Tire Pressure Monitoring Display, Adapting	46
2.33 Windshield Washer System, Checking and Adjusting Spray Nozzles	46
2.34 Headlamp Washer System, Checking Spray Nozzles	49
2.35 Windshield Wiper Blades, Checking End Position and for Damage	49
2.36 Service Display, Resetting or Adapting	49
2.37 Install Fuse for Headlamp Washer System	52
2.38 Dust and Pollen Filter, Removing and Installing	53
2.39 Tie Rods, Control Arms, Ball Joint and Driveshafts, Checking Play, Fit and Sealing Boots	54
2.40 Transport Mode, Deactivating using VAS 5051/5052	54
2.41 Door Arrester, Door Hinge and Lock Cylinder, Lubricating	55
2.42 Transport Protection, Removing Front and Rear Suspension Strut Protectors	56
2.43 Underbody Protection, Inspecting for Damage	56
2.44 Plenum Chamber Water Drain, Checking and Cleaning	56

2.45	Factory-Equipped Winter Tires	56
2.46	Clock, Setting	57
2.47	Spark Plugs, Removing and Installing	57

03 – Maintenance, Diagnosis

1 General Information

- ⇒ ["1.1 Engine Overview", page 1](#)
- ⇒ ["1.2 Type Plate and VIN", page 4](#)
- ⇒ ["1.3 Raising Vehicle", page 6](#)
- ⇒ ["1.4 Tow Starting/Towing", page 7](#)
- ⇒ ["1.5 Vehicle Checks during Inspection and Maintenance", page 9](#)

1.1 Engine Overview

Code letters		CBRA
Displacement	liter	3.189
Output	kW at RPM	184/6300
Torque	Nm at RPM	320/2500 to 3000
Bore	dia. mm	84
Stroke	mm	95.9
Compression ratio		10.85
RON	at least	98 ¹⁾
Fuel injection and ignition system		Motronic
Ignition sequence		1-5-3-6-2-4
Emissions values		LEV2
Exhaust gas recirculation		no
Turbocharger, G-Charger		no
Oxygen sensor regulation		4 sensors
Variable valve timing		yes
Variable intake manifold		yes
Secondary Air Injection System		yes
Valve per cylinder		4
<ul style="list-style-type: none"> • ¹⁾ Super unleaded RON 95 is permissible, although with reduced power. 		

Engines	⇒	
Engine Code		BUB
Displacement		3.2L
Number of cylinders/valves per cylinder		6/4
Emissions category		EU IV
Output	kW at RPM	184 / 6333
Torque	Nm at RPM	320 / 2500
Bore	∅ mm	84.0
Stroke	mm	95.5
Compression ratio		10.85:1
Fuel injection/Ignition		MPI
RON	minimum.	98 unleaded ¹⁾



1) 95 RON Super unleaded gasoline is permissible, however with decreased power output

Engines		⇒		Gasoline engines	
Engine Code		CCZA		CDMA	
Displacement	liter	2.0		2.0	
Number of cylinders/valves per cylinder		4/4		4/4	
Emissions category		EU V		EU IV	
Output	kW at RPM	147 / 5100 - 6000		195 / 6000	
Torque	Nm at RPM	280 / 1800 - 5000		350 / 2500 ... 5250	
Bore	∅ mm	82.5		82.5	
Stroke	mm	92.8		92.8	
Compression ratio		9.8:1		9.8:1	
Fuel injection/Ignition		TFSI		TFSI	
RON	minimum.	98 unleaded ¹⁾		98 unleaded ¹⁾	

1) 95 RON Super unleaded gasoline is permissible, however with decreased power output

Code letters		CETA
Displacement	liter	1.984
Output	kW at RPM	155/4200
Torque	Nm at RPM	350/1500
Bore	dia. mm	82.5
Stroke	mm	92.8
Compression ratio		9.6
RON		95 ¹⁾
Fuel injection and ignition system		FSI
Ignition sequence		1-3-4-2
Knock control		yes
Turbocharger		yes
Exhaust gas recirculation		no
Variable intake manifold		no
Variable valve timing		yes
Secondary air injection (AIR)		no
<ul style="list-style-type: none"> ¹⁾ Unleaded RON 91 is also permissible, although with reduced power. 		

Code letters		CEPB
Displacement	liter	2.480
Output	kW at RPM	265/5700 to 6300
Torque	Nm at RPM	465/1750 to 5300
Bore	dia. mm	82.5
Stroke	mm	92.8
Compression ratio		10
RON		98 ¹⁾
Fuel injection and ignition system		Bosch Motronic
Ignition sequence		1-2-4-5-3
Knock control		2 Sensors
Turbocharger		yes
Exhaust gas recirculation		no
Exhaust temperature control		1 Sensors
Charge air cooler		yes
Oxygen sensor regulation		yes
Valves per cylinder		4
Variable intake manifold		no
Secondary air injection (AIR)		no
<ul style="list-style-type: none"> ¹⁾ Super Unleaded RON 95 is also permissible, although with reduced power. 		

Code letters		CCTA
Displacement	liter	1.984
Output	kW at RPM	147/5100
Torque	Nm at RPM	280/1700
Bore	dia. mm	82.5
Stroke	mm	92.8
Compression ratio		9.6
RON		98 ¹⁾
Fuel injection and ignition system		FSI
Ignition sequence		1-3-4-2
Knock control		yes
Turbocharger		yes
Exhaust gas recirculation		no
Variable intake manifold		no



Code letters	CCTA
Variable valve timing	yes
Secondary air injection (AIR)	no
<ul style="list-style-type: none"> ¹⁾ Unleaded RON 95 is also permissible, although with reduced power. 	

Code letters		BWA	BPY
Displacement	liter	1.984	1.984
Output	kW at 1/rpm	147/5100	147/5700
Torque	Nm at rpm	280/1800	280/2000
Bore	Diameter in mm	82.5	82.5
Stroke	mm	92.8	92.8
Compression ratio		10.3	10.5
RON		98 ¹⁾	98 ¹⁾
Fuel injection and ignition system		FSI	FSI
Ignition sequence		1-3-4-2	1-3-4-2
Knock control		yes	yes
Charging		yes	yes
Exhaust gas recirculation		no	no
Variable intake manifold		no	no
Variable valve timing		yes	yes
Secondary air injection (AIR)		no	no
<ul style="list-style-type: none"> ¹⁾ Unleaded RON 95 is also permissible, although with reduced power. 			

1.2 Type Plate and VIN

A - Type plate

- It is secured on the right suspension strut tower.

B - Vehicle Identification Number

- It is stamped in the upper wheel housing right longitudinal member near the reservoir.

WAU	ZZZ	8J	Z	7	A	000 001
Manufacturer code	Filler character	Type	Filler character	Model year 2007	Producing Factory	Serial number

Vehicle Data Label

The vehicle data label is in the customer's Maintenance booklet and in the vehicle in the spare wheel recess or on the floor panel.

The label contains the following vehicle data:

- 1 - Vehicle Identification Number (VIN)
- 2 - Model identification number/Production control number
- 3 - Model explanation
- 4 - Engine output/Emissions standard/Transmission
- 5 - Engine and transmission codes (no information for certain countries)
- 6 - Paint number/interior equipment identification number
- 7 - Optional equipment identification numbers
- 8 - Curb weight/Consumption/CO₂ emissions (no information for certain countries)

Engine Code and Engine Identification



Note

The "engine code" is on the vehicle data label in the Maintenance booklet and in the spare wheel recess or on the floor panel.

A label with engine code and engine number is also applied to the toothed belt guard.

4-Cylinder Engines:

Engine number ("engine code" and "serial number") is located at front of engine/transmission connecting point.

1	TRUZZZ	8J6	71000237
2	8J3	02C	1878064
3	TTC	2.0	R4
4	147 KW	M6S	11 / 05
5	---		---
6	LY7W/LY7W	N2J/JN	
7	X9X BOA C8G GOK HDO JOR		
	D2L Q1D 0JG 1AT 1GO 2PV		
	5RU 5SL T59 0YK		
	4UF OG4 8UD 8GU 8RY 1KZ		
	1LJ 3FA	1BA	
8	1355	11.1	11.1 11.1 111

A00-10199

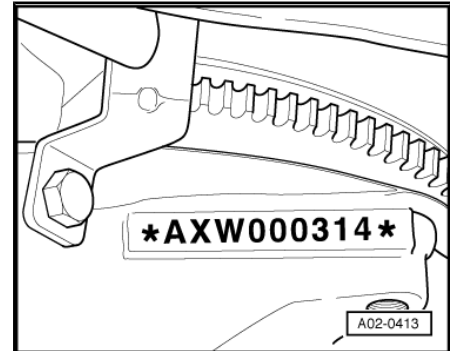

6-Cylinder Engines:

The engine number and engine code -arrow- are stamped on the cylinder block near the vibration damper.

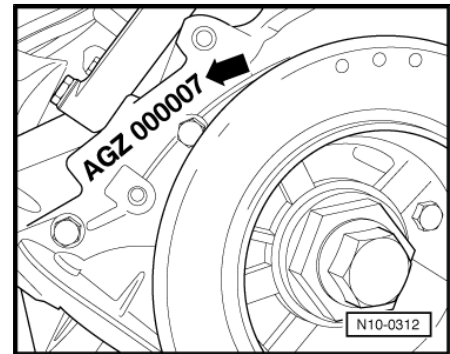

1.3 Raising Vehicle



WARNING

- ◆ *Before driving the vehicle onto a workshop hoist, make sure there is enough clearance between any low-lying components and the hoist.*
- ◆ *On the Audi TT's and on the S line vehicles, we recommend using ramps T 40081 if the lift arms on a vehicle hoist are too thick to prevent damage.*
- ◆ *Before driving a vehicle onto a lifting platform it must be ensured that the vehicle weight does not exceed the permissible lifting capacity of the platform.*
- ◆ *Vehicle may only be lifted at points indicated in illustration in order to avoid damaging vehicle floor pan and to prevent vehicle from tipping.*
- ◆ *Never start engine and engage a gear with vehicle lifted so long as even one wheel has contact with the floor! There is a risk of an accident if this is not observed!*
- ◆ *If work is to be performed under vehicle it must be supported by suitable stands.*

Floor Jack

Always use a suitable rubber or wooden block between the jack and the vehicle.

A floor jack must be attached only at the mounting points depicted in the illustration.

Do not lift the vehicle at the engine oil pan, transmission, or on front or rear axles as serious damage may result.

Hoist and Floor Jack Lifting Points

Front:

On the floor longitudinal reinforcement in the area of the marking.

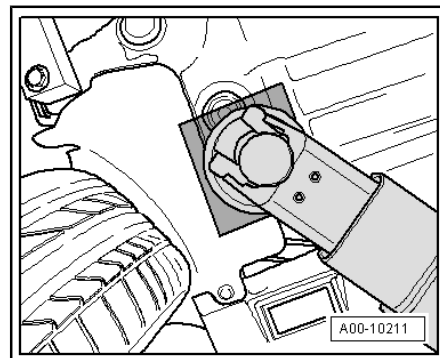

Rear:

On aluminum case part in front of rear axle mounting point

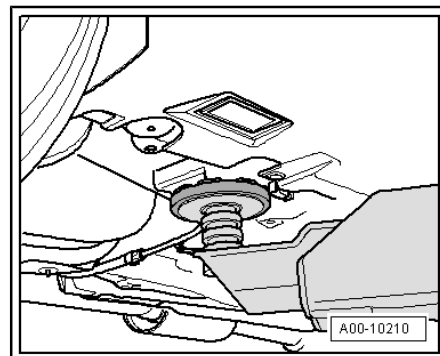

1.4 Tow Starting/Towing

- Attach tow rope or bar only at following eyes:

Front Towing Eyes

- Open cover.

Screw towing eye in by hand and tighten counter-clockwise using wheel bolt wrench.

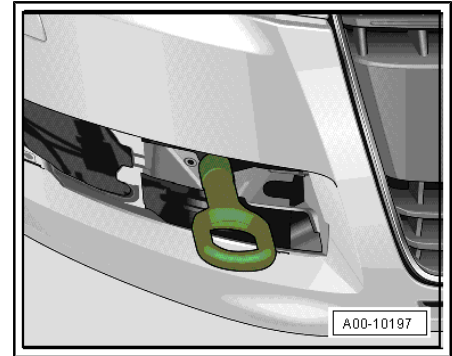



Rear Towing Eye

The rear towing eye is located under the bumper cover on the rear right.

- Screw towing eye in by hand and tighten counter-clockwise using wheel bolt wrench.

Tow starting or towing vehicle



Note

- ◆ *Tow-ropes or bars should be attached at above mentioned points only.*
- ◆ *The tow-rope should be able to stretch to reduce the risk of damage to both vehicles. Therefore only ropes of synthetic material or rope from similarly flexible material should be used. However it is safer to use a tow bar!*
- ◆ *Avoid excessive towing effort and do not jerk. During towing operations on unsurfaced roads there is always a danger that the attachment points will be overstressed and damaged.*
- ◆ *Vehicle towing should only be done if it is not possible to start the engine with the starting assist cable.*

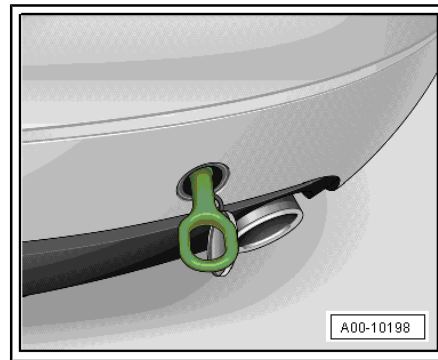

If the vehicle must ever tow or be towed, observe the following:

- ◆ Legal regulations concerning towing must be observed.
- ◆ Both drivers must be familiar with towing procedures. Inexperienced drivers should not attempt to tow start or tow.
- ◆ When using a tow rope the driver of the towing vehicle must engage the clutch very gently when moving off and changing gear.
- ◆ The driver of the vehicle being towed must ensure that the tow rope is always taut.
- ◆ Both vehicles must have the emergency flasher switched on - if necessary observe any other regulations.
- ◆ The ignition must be switched on, so that the steering wheel is not locked and the turn signals, horn, windshield wipers, and windshield washer system can be operated.
- ◆ Since the brake booster only works with the engine running, the brake pedal must be stepped on with substantially more force when the engine is switched off.
- ◆ With the engine switched off, the power steering also does not work, increasing the amount of steering effort.
- ◆ Without lubricants in the manual transmission and/or automatic transmissions the car may only be towed with raised drive wheels.

Important notes concerning tow starting a vehicle:

It is generally recommended not to tow start vehicles. Instead, jumper cables should be used.

There are several reasons to not tow start:

- ◆ During tow starting, the risk of an accident occurring is high, e.g. driving into vehicle towing.
- ◆ Vehicles with gasoline engines can be damaged by unburned fuel entering the catalytic converter.
- ◆ Tow starting of vehicles with automatic transmission is not possible for technical reasons.

If a vehicle should be tow started at any time, observe the following:

- Before tow starting, push in clutch pedal and hold, and select gear 2 or 3.
- Switch ignition on.
- When both vehicles are in motion, release the clutch pedal.
- As soon as the engine is started, push in the clutch and take the car out of gear to avoid running into the towing vehicle.



Note

Vehicles with catalytic converter (gasoline engine only) must not be started when the catalytic converter is at operating temperature and pulling the vehicle over a longer distance of more than 50 m. Otherwise, the vehicle could be damaged by unburned fuel entering the catalytic converter.

When towing a vehicle with automatic transmission the following additional points must be observed:

- ◆ Selector lever must be in the "N" position.
- ◆ Do not tow at speeds greater than 30 mph (50 km/h).
- ◆ The maximum towing distance is 30 miles (50 km).

For longer distances, the front end of the vehicle must be raised.

Reason: With engine switched off, the transmission oil pump does not work. Therefore the transmission is not sufficiently lubricated at higher speeds and longer distances.

When towing with a tow truck, the vehicle may only be towed with raised front wheels.

Reason: With car raised in the back, the driveshafts turn backwards. This would cause the planetary gears in the automatic transmission to achieve such high RPM that the transmission would be heavily damaged within a very short time.



Note

If normal towing of the vehicle is not possible, the vehicle must be transported with a special transporter or trailer. This also applies to towing distances of over 30 miles (50 km)

1.5 Vehicle Checks during Inspection and Maintenance

For vehicle checks, we recommend interactive acceptance VAS 5000 and performance test stand V.A.G 1858.

Brakes, Testing

Information for checking brakes on FWD and AWD vehicles is in the corresponding brake system repair manual.

Performance Check

Perform performance check on performance test stand recommended by Audi. The corresponding correction factors for automatic transmissions and AWD are provided in these test stands. Vehicles with AWD may only be tested on a four-wheel performance test stand.

Tachometer Check

With the tachometer test, the vehicle wheels are driven. Vehicles with AWD may only be tested on a four-wheel test stand.

Shock Absorber Check

Information on testing shock absorbers can be found in the suspension repair manual.

2 Maintenance Procedures

- ⇒ ["2.1 Strut Tube Cap, Lubricating", page 13](#)
- ⇒ ["2.3 Battery, Checking Level Using Guided Fault Finding", page 14](#)
- ⇒ ["2.4 Battery, Checking No Load Voltage before Starting Engine", page 15](#)
- ⇒ ["2.5 Battery, Check Fluid Level", page 17](#)
- ⇒ ["2.6 AGM Battery, Checking", page 19](#)
- ⇒ ["2.7 Battery, Checking Cables for Secure Seating", page 20](#)
- ⇒ ["2.8 Tires, Checking", page 20](#)
- ⇒ ["2.9 Brake System, Inspecting for Leaks and Damage", page 22](#)
- ⇒ ["2.10 Brake Pads, Checking Thickness", page 22](#)
- ⇒ ["2.11 Brake Fluid, Checking Depending on Brake Pad Wear", page 23](#)
- ⇒ ["2.12 Brake Fluid, Changing", page 24](#)
- ⇒ ["2.13 Fuel Injector Cleaner G17", page 27](#)
- ⇒ ["2.14 Key, Check Functionality", page 28](#)
- ⇒ ["2.15 DTC Memory, Checking", page 28](#)
- ⇒ ["2.16 Engine Compartment Front Noise Insulation Cover, Removing and Installing", page 28](#)
- ⇒ ["2.17 Coolant System, Checking", page 29](#)
- ⇒ ["2.18 Instrument Cluster, Selecting Language", page 30](#)
- ⇒ ["2.19 Air Filter, Cleaning Housing and Removing and Installing Filter", page 31](#)
- ⇒ ["2.20 Haldex Clutch Oil, Changing", page 37](#)
- ⇒ ["2.21 Hood Safety Catch, Lubricating", page 37](#)
- ⇒ ["2.22 Engine Cover, Removing", page 37](#)
- ⇒ ["2.23 Engine and Engine Compartment from Underneath, Inspecting for Leaks and Damage", page 39](#)
- ⇒ ["2.24 Engine Oil, Draining/Extracting and Removing and Installing Filter", page 40](#)
- ⇒ ["2.25 Hood Hinge, Lubricating", page 43](#)
- ⇒ ["2.26 Engine Oil, Filling", page 43](#)
- ⇒ ["2.27 Engine Oil Level, Checking", page 44](#)
- ⇒ ["2.28 Navigation Eject Button, Unlocking", page 44](#)
- ⇒ ["2.29 Radio, Entering Security Code to Activate Anti-Theft Coding", page 44](#)
- ⇒ ["2.30 Road Test", page 45](#)
- ⇒ ["2.31 Wheel Bolts, Tightening Specifications", page 46](#)
- ⇒ ["2.32 Tire Pressure Monitoring Display, Adapting", page 46](#)
- ⇒ ["2.33 Windshield Washer System, Checking and Adjusting Spray Nozzles", page 46](#)
- ⇒ ["2.34 Headlamp Washer System, Checking Spray Nozzles", page 49](#)

page 53

⇒ [“2.39 Tie Rods, Control Arms, Ball Joint and Driveshafts, Checking Play, Fit and Sealing Boots”, page 54](#)

⇒ [“2.40 Transport Mode, Deactivating using VAS 5051/5052”, page 54](#)

⇒ [“2.41 Door Arrester, Door Hinge and Lock Cylinder, Lubricating”, page 55](#)

⇒ [“2.42 Transport Protection, Removing Front and Rear Suspension Strut Protectors”, page 56](#)

⇒ [“2.43 Underbody Protection, Inspecting for Damage”, page 56](#)

⇒ [“2.44 Plenum Chamber Water Drain, Checking and Cleaning”, page 56](#)

⇒ [“2.45 Factory-Equipped Winter Tires”, page 56](#)

⇒ [“2.46 Clock, Setting”, page 57](#)

⇒ [“2.47 Spark Plugs, Removing and Installing”, page 57](#)

2.1 Strut Tube Cap, Lubricating

Special tools and workshop equipment required

- ◆ Lubricant G 000 405 A2

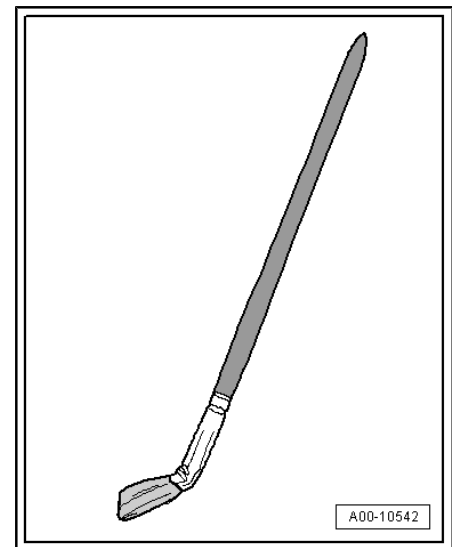

- ◆ Brush

Coat the plastic cap on the strut tube on the contact surface -arrow- with lubricant G 000 405 A2.

i Note

After removing the spring clip and the spacer and lubricating the strut tube cap, make sure that the boot in the strut bearing is in the correct position as with the shock absorber tube.

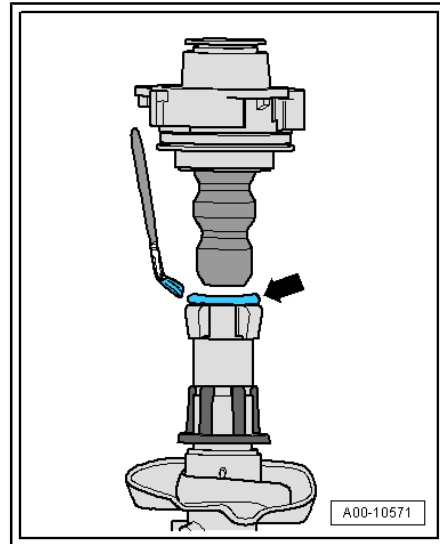

2.2 Measured Values Block 32, Reading

i Note

Applies to certain countries only. Refer to the Maintenance table.

- Follow these steps in sequential order.
- ◆ Connect VAS 5051/5052
- ◆ On Board Diagnostic
- ◆ Engine electronics
- ◆ Measured value blocks
- ◆ Select measured values block 32
- ◆ Display field 2 (4-cylinder engines)
- ◆ Display field 2 and 4 (V6 and V8 engines)

i Note

If the values deviate by > 15%, then the Fuel Injector Cleaner G17, refer to => ["2.13 Fuel Injector Cleaner G17"](#), page 27 must be increased by a factor of 4.

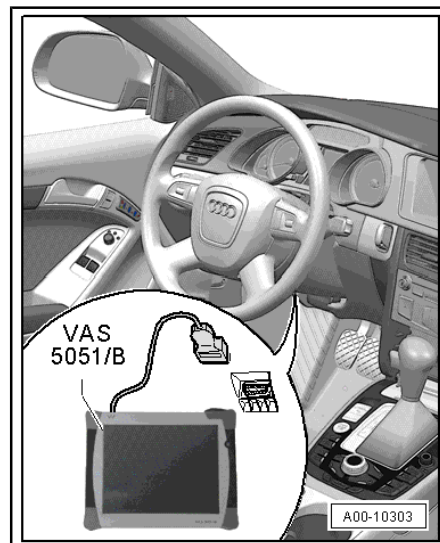

2.3 Battery, Checking Level Using Guided Fault Finding

- Follow these steps in sequential order.

- ◆ Connect VAS 5051/5052
- ◆ Guided Fault Finding or Guided Functions
- ◆ Select brand and type.
- ◆ Service Work
- ◆ Check the battery -A-
- ◆ Continue following the instructions.
- ◆ Send the diagnostic protocol online.

 **Note**

If tester display shows charge or replace battery. Refer to ⇒ Electrical Equipment; Rep. Gr. 27; Removal and Installation



2.4 Battery, Checking No Load Voltage before Starting Engine

 **Note**

For delivery inspection only for vehicles without battery monitoring control module -J367- or energy management control module -J644- .

Special tools and workshop equipment required

- ◆ Portable multimeter -V.A.G 1526C-

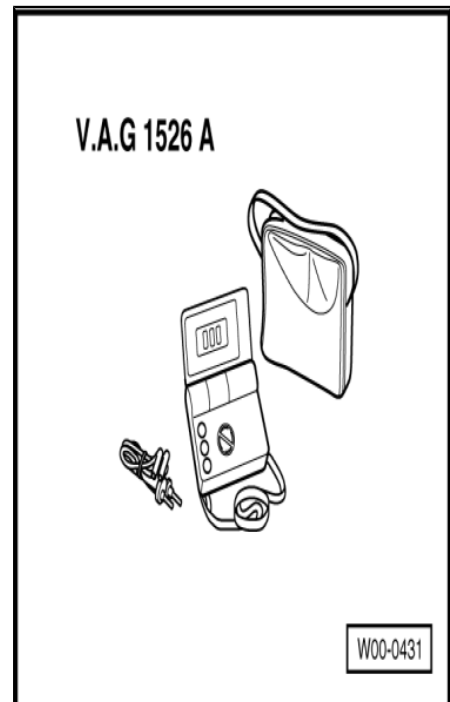

- Make sure the following points are observed - otherwise a correct measurement cannot be guaranteed.

- ◆ Battery must not be loaded by connected electrical components for at least 12 hours before testing.
- ◆ The battery must not be charged for at least 12 hours before measuring.

Remove rear molded insert -3- for tools under luggage compartment floor cover.

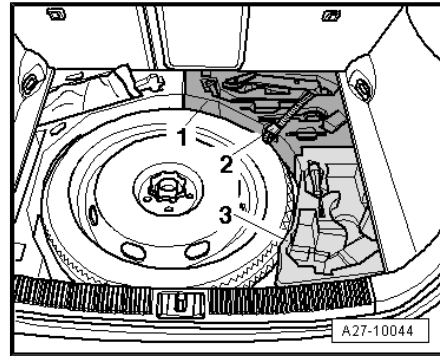

- Remove battery compartment cover -arrow-.

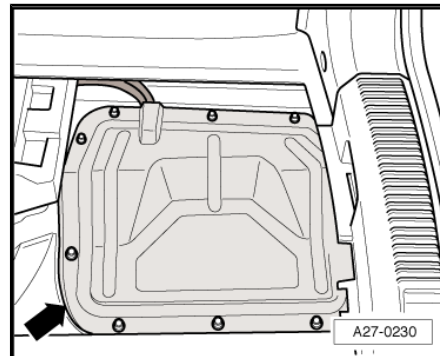

- Remove molded insert under battery.

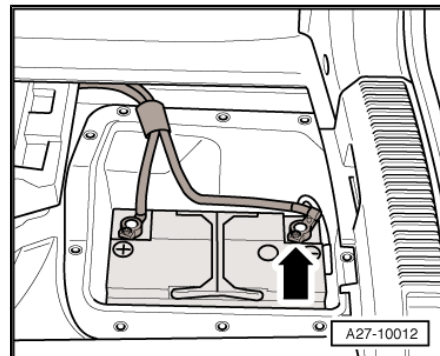

- Measure voltage between the battery terminals -2- and -3- with the ignition switched off.
- 1 - If tester shows 12.5 V or higher, battery is O.K.
- 2 - If the tester shows 12.2 to 12.5 Volts, battery should be charged. Refer to ⇒ Electrical Equipment; Rep. Gr. 27 ; Removal and Installation .
- 3 - If the tester shows a value between 11.6 and 12.2 Volt, the following procedure must be used: Charge battery, refer to ⇒ Electrical Equipment; Rep. Gr. 27 ; Removal and Installation . Let the battery sit for 24 hours after charging it. Perform a battery test/ battery load test after the waiting period. Refer to ⇒ Electrical Equipment; Rep. Gr. 27 ; Removal and Installation .
- 4 - If measured value is 11.6 Volt or lower, battery must be replaced. Refer to ⇒ Electrical Equipment; Rep. Gr. 27 ; Removal and Installation .

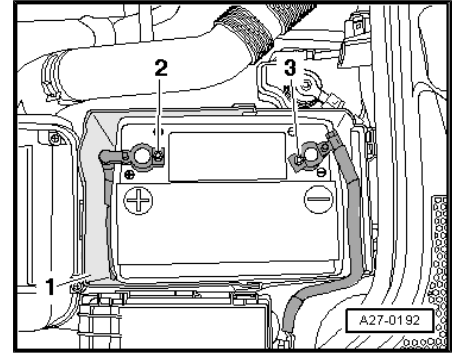

 **WARNING**

Always follow procedure exactly, otherwise measured values could be incorrect.

2.5 Battery, Check Fluid Level

⇒ ["2.5.1 General Information", page 17](#)

⇒ ["2.5.2 Battery without Visual Indicator", page 18](#)

⇒ ["2.5.3 Battery with Visual Indicator", page 18](#)

2.5.1 General Information

 **Note**

Batteries with or without visual indicator must not be opened.

The battery is located at the rear right of the luggage compartment.

- Switch ignition off and remove ignition key.
- Remove rear molded insert -3- for tools under luggage compartment floor cover.

 **Note**

Ignore -1- and -item 2-.

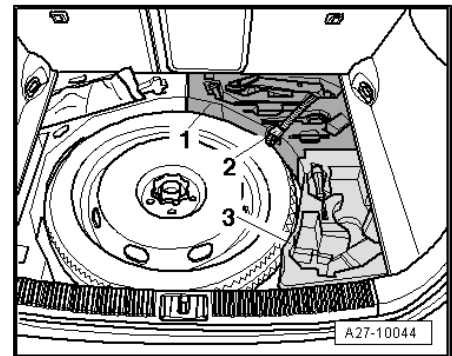

- Remove battery compartment cover -arrow-.
- Remove molded insert under battery.

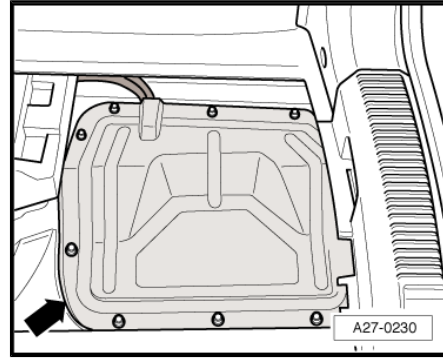

2.5.2 Battery without Visual Indicator

- ◆ On batteries with visible min and max markings, electrolyte level only needs to be checked visually.
- ◆ The electrolyte level must be above the MIN marking.
- ◆ Use a flashlight to improve visibility when performing an exterior visual inspection of the min and max markings.



Caution

Replace the battery if the electrolyte level is below the minimum marking! Refer to ⇒ Electrical Equipment; Rep. Gr. 27; Removal and Installation .

2.5.3 Battery with Visual Indicator

- ◆ As the “visual indicator” is only located in a battery cell, only the battery electrolyte level for this battery cell can be checked.
- ◆ The “visual indicator” -arrow- provides information about the fluid levels and the state of charge for the battery being checked.
- ◆ Bubbles can build up under the “visual indicator” when the battery is charging and also while driving, causing the color displayed to be incorrect.

- Loosen the bubbles under the "visual indicator" by lightly and carefully hitting the "visual indicator" -arrow- with the handle of a screwdriver.

Read the battery electrolyte level present in the color display. Two different displays are possible:

Color display	Battery level
Black or green	• Battery electrolyte level OK
Colorless or light yellow	• Battery electrolyte level too low. Risk of explosion, do not check or charge the battery.

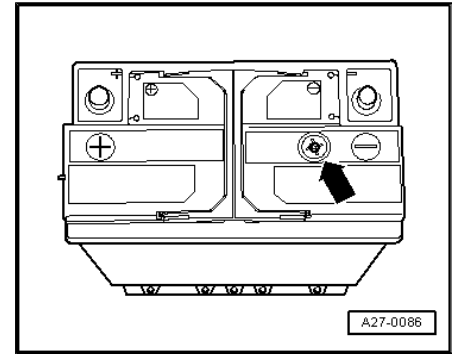

WARNING

Risk of explosion by charging the battery with "visual indicator".

If the "visual indicator" is colorless or light yellow, do not check or charge the battery. Do not try to jump start it! There is a risk of explosion when checking, charging, or jumping the battery. The battery must be replaced! Refer to ⇒ Electrical Equipment; Rep. Gr. 27 ; Removal and Installation .

2.6 AGM Battery, Checking



Note

- ◆ *AGM batteries are marked with "AGM".*
- ◆ *The AGM battery is closed, needs no maintenance, and must not be opened.*

Perform a visual inspection of the battery:

- 1 - Corrosion on the battery pole
- 2 - Battery terminal and battery secure
- 3 - Damage to the battery terminals and housing



Caution

The crash safety is reduced if an incorrect battery is installed.

Always replace an AGM battery with another AGM battery if that is what the vehicle originally had installed. Refer to ⇒ Electrical Equipment; Rep. Gr. 27 ; Removal and Installation .

2.7 Battery, Checking Cables for Secure Seating

- Check the battery terminals for secure seating and tighten nuts -1- and -4- if necessary.



WARNING

If the battery clamp is not seated securely on the positive terminal, disconnect battery Ground (GND) strap on battery negative terminal first, to prevent possible accidents.

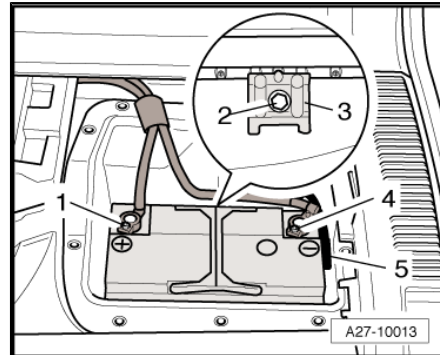

- Check battery for secure fit, tighten screws -2- on securing bracket -3- if necessary.

Tightening Specifications	Nm
Battery terminals to battery pole	5
Screw to securing bracket	22

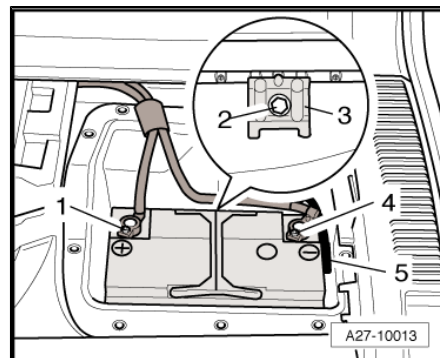

2.8 Tires, Checking

⇒ ["2.8.1 General Information", page 20](#)

⇒ ["2.8.2 Tire Pressure, Correcting", page 21](#)

⇒ ["2.8.3 Spare Tire", page 21](#)

2.8.1 General Information



Note

Wheels and tires of the same construction and size should be used on the front and back. On vehicles with AWD, tires should also be of the same make and have the same tread.

Delivery Inspection

- Check running surfaces and side walls for damage, remove foreign bodies, if necessary.

Inspection Service

- Check tire treads for cupping, feathering, one-sided tread wear, porous side walls, cracks, cuts, and rim damage.



WARNING

Inform the customer of any damage found.

Tires, Checking Wear Pattern

- The wear pattern of the front wheels can be used to assess whether a check of the track and camber is necessary:
- ◆ Feathered edges of the treads may indicate faulty toe adjustment.
- ◆ One-sided tread wear is mostly caused by faulty camber.

 **Note**

If such wear patterns are found, determine the causes by checking the wheel alignment (repair measure).

Tread Depth, Checking

- ◆ Minimum tread depth: 1.6 mm

 **Note**

- ◆ *This value may vary for individual countries due to different legislative regulations.*
- ◆ *If the tread wear is close to the wear limits, inform customer and note findings on the repair order.*

2.8.2 Tire Pressure, Correcting

The tire pressure value are on the label on the B-pillar.

 **Note**

Observe that the inflation pressure specifications on the label refer to the air pressure of cold tires. Do not reduce tire pressure when the tires are warm.

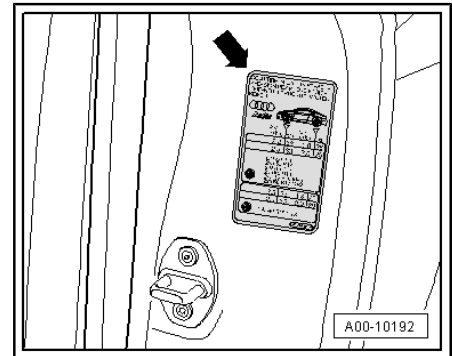

2.8.3 Spare Tire

- Spare wheel with standard tire

Maintain the highest specified tire pressure for the tire size according to the tire pressure label.

- Mini spare tire

The tire pressure is on the sidewall.

- Break-down kit

Tire Repair Kit, Checking Expiration Date

 **Note**

Tire valves must be sealed with valve caps. Otherwise, dirt can enter valve needle which becomes jammed and can no seal shut.

2.9 Brake System, Inspecting for Leaks and Damage

- Check the following components for leaks and damage:
 - ◆ Brake Master Cylinder
 - ◆ Brake Booster
 - ◆ ABS Hydraulic unit
 - ◆ Calipers
- Make sure the brake hoses are not twisted.
- Make sure the brake hoses do not come in contact with any vehicle components when steering is at full lock.
- Check brake hoses for porosity, bubbles and cracks.
- Check brake hoses for chafing.
- Check the brake line connections for leaks or corrosion and make sure they are attached securely.



WARNING

Eliminate any malfunctions (repair procedure).

2.10 Brake Pads, Checking Thickness

Special tools and workshop equipment required

- ◆ Test pin -T40139-

Test Pin

To determine brake pad thickness, the sliding ring must be slid as far as stop in the direction of the measure point.

then bring measuring point of test pin through rim and into contact with brake pad and slide test pin evenly in direction of brake pad until the test pin touches the brake pad backing plate.

Then remove test pin and read out value on scale marked with brake symbol



Note

- ◆ *Make sure the sliding ring does not move, otherwise the measurement will be incorrect.*
- ◆ *The second scale on the test pin (tire symbol) can be used to determine the tire tread depth.*

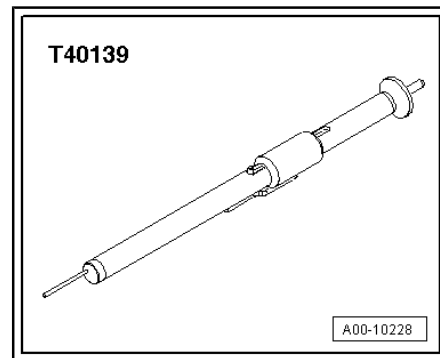

Front Disc Brake Pads

- a - Brake pad thickness including backing plate
- Wear limit: 7

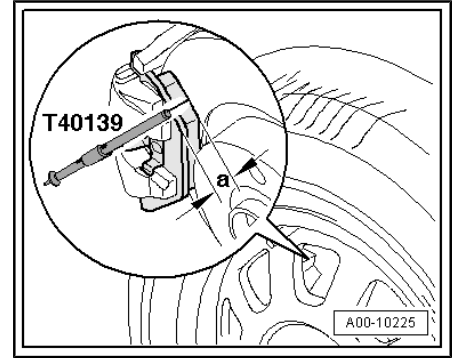

Rear Disc Brake Pads

- a - Brake pad thickness including backing plate
- Wear limit: 7

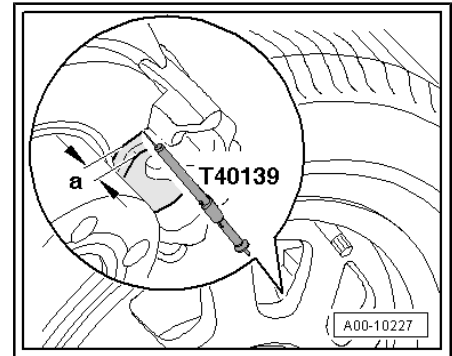

WARNING

With pad thickness (including backing plate) of 7 mm, the brake pads have reached their wear limit and must be replaced (repair procedure). Inform the customer.



Note

- ◆ *On some vehicles, due to the shape of the rims (accessory rims), it may not be possible to bring the test pin through the rim and into contact with the brake disc or pad. If this is the case, use the following procedure:*
- ◆ *Determine thickness of outer pads by checking visually (using a flashlight through a hole in wheel).*
- ◆ *Determine thickness of the inner pad by visual check (using a flashlight through a hole in the wheel).*

2.11 Brake Fluid, Checking Depending on Brake Pad Wear



Note

Use only new Original VW / Audi brake fluid: refer to the Parts Catalog



WARNING

- ◆ *Brake fluid is poisonous. Do not let brake fluid come in contact with the paint.*
- ◆ *Brake fluid is hygroscopic, meaning that it absorbs moisture from the surrounding air, and must therefore always be stored in air-tight containers.*

- Please observe the following:

2.11.1 Delivery Inspection

- ◆ Fluid level must be at MAX mark

Note

To prevent the brake fluid from overflowing from the reservoir, the level must not be over the MAX mark.

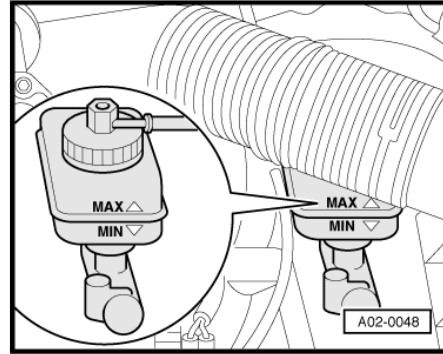

2.12 Brake Fluid, Changing

⇒ [“2.12.1 General Information”, page 24](#)

⇒ [“2.12.2 Brake Fluid, Changing using Brake Charger/Bleeder Unit VAS 5234”, page 24](#)

⇒ [“2.12.3 Sequence and Brake Fluid Capacity Table”, page 27](#)

2.12.1 General Information

Note

Use only new Original VW / Audi brake fluid: refer to the Parts Catalog.

Change brake fluid with brake charger/bleeder unit -VAS 5234-



WARNING

- ◆ Brake fluid must never come into contact with fluids containing mineral oils (oil, gas, cleaning solutions). Oils containing minerals damage plugs and sleeves on brake systems.
- ◆ Brake fluid is poisonous and must not be extracted by mouth using a hose under any circumstances. In addition, it must not come into contact with paint due to its corrosive effects.
- ◆ Brake fluid is hygroscopic, meaning that it absorbs moisture from the surrounding air, and must therefore always be stored in air-tight containers.
- ◆ Observe waste disposal regulations!

2.12.2 Brake Fluid, Changing using Brake Charger/Bleeder Unit VAS 5234

Special tools and workshop equipment required

◆ Brake charger/bleeder unit -VAS 5234-

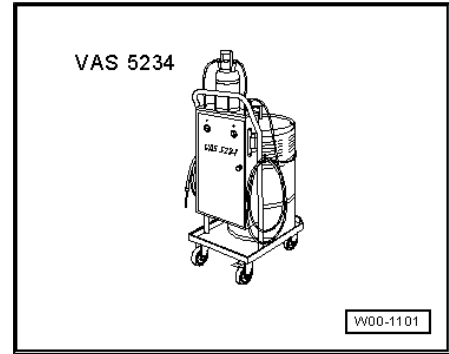

◆ Reservoir

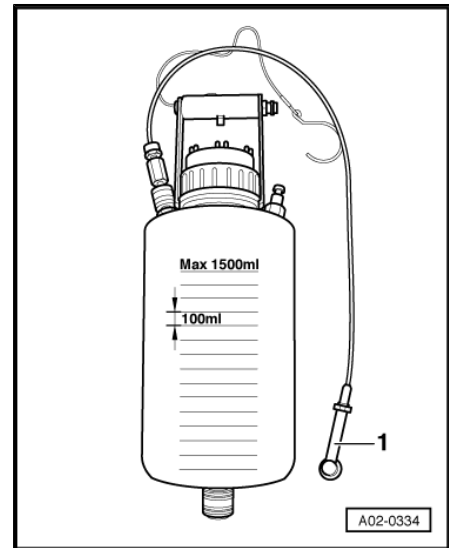

Note

- ◆ *The brake fluid level in the reservoir must be high enough so that air cannot get into the brake system.*
 - ◆ *Do not remove the strainer inside the brake fluid reservoir.*
 - ◆ *Follow -VAS 5234- operating instructions!*
- Remove brake fluid reservoir cap -1-.

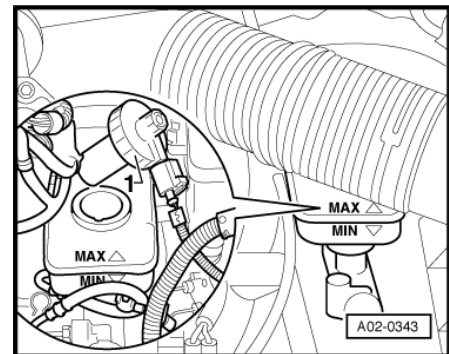

- Use the hose from the -VAS 5234- to extract as much brake fluid as possible.



WARNING

Do not reuse used / extracted brake fluid!

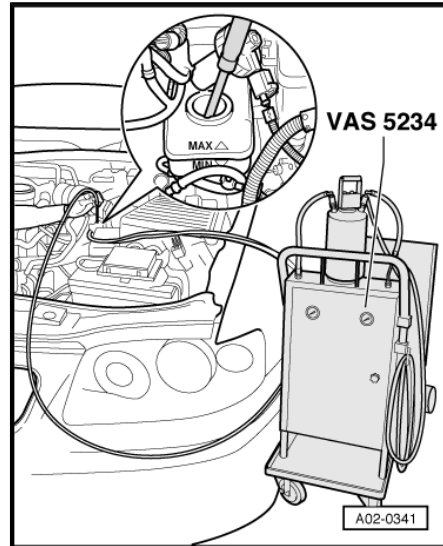

- Install adapter -1- to brake fluid reservoir.
- Connect filler hose -2- on -VAS 5234- to adapter.

Manual Transmission

- Pull cover cap off clutch slave cylinder bleed screw.

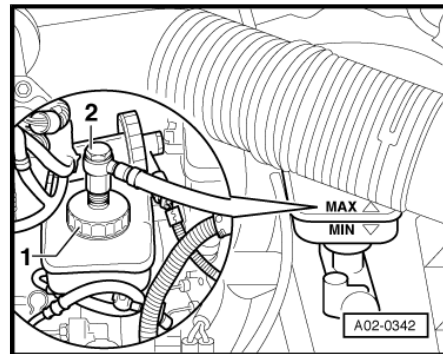

- Place extractor bleeder hose -1- on clutch slave cylinder bleeder screw, open bleeder screw, and let about 100 ml drain out. Close bleeder screw and install cover cap.
- Operate clutch pedal several times.

All Vehicles

- Remove caps from the bleeder screws.
- Connect extractor bleeder hose -1- to front left bleeder screw, open bleeder screw and allow about 200 ml to flow out. Close bleeder screw.

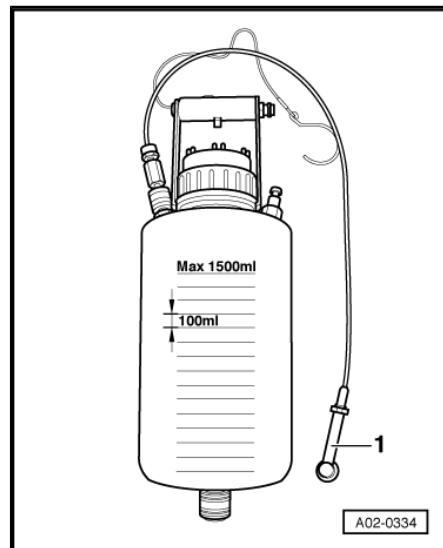

- Repeat work sequence on other side of vehicle at front.
- Connect extractor bleeder hose -1- to rear left bleeder screw, open bleeder screw and allow about 200 ml to flow out. Close bleeder screw.
- Repeat procedure on opposite rear.
- Install cover caps on brake caliper bleeder screws.
- Move filler lever on -VAS 5234- to position -B- (see operating instructions).
- Remove the filler hose from the adapter.
- Remove the adapter from the brake fluid reservoir.
- Install the brake fluid reservoir cap.
- Check brake fluid level and fill if necessary.
- Check pedal pressure and brake pedal free play. Free play: max $\frac{1}{3}$ of pedal travel

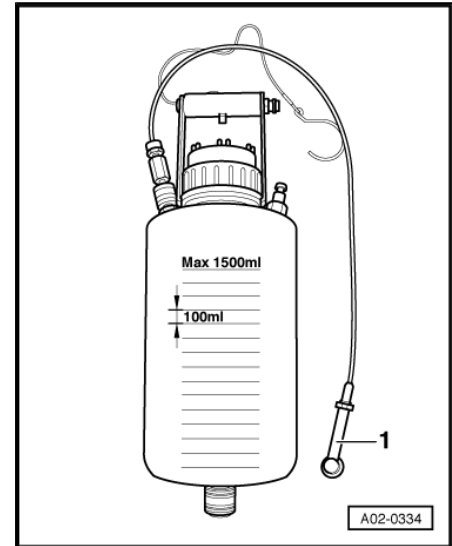

2.12.3 Sequence and Brake Fluid Capacity Table

Left front	200 ml
Right front	200 ml
Left rear	200 ml
Right rear	200 ml
Clutch slave cylinder	200 ml
Total amount	1000 ml

2.13 Fuel Injector Cleaner G17



Note

Applies to certain countries only. Refer to the Maintenance table.

- ◆ Add Fuel Injector Cleaner G17 into the fuel tank in a ratio of 10ml of additive for every 10 liters of fuel.
- ◆ The following table shows the required quantities for each fuel level shown in the fuel gauge.

Mixture Ratio

Fuel gauge	G17 additive
Approximately 1/4	Approximately 15 ml
Approximately 1/2	Approximately 30 ml
Approximately 3/4	Approximately 45 ml
Approximately 1/1	Approximately 60 ml



Note

- ◆ *The values in the table are based on an 60 liter fuel tank.*
- ◆ *If there are other fuel capacities in the fuel tank which are not mentioned in the table, then add 10 ml of additive for every 10 liters of fuel.*

2.14 Key, Check Functionality

- Separate keys so that the function of each key can be checked individually.
- Insert each key into the ignition and start the engine.
- If engine switches off by itself after about 3 seconds and "save" appears in the odometer display, the key has not been programmed to the immobilizer.
- Repair measure: Guided Fault Finding (Programming vehicle keys).
- Note in the delivery check list the number of keys checked and given to the owner.

2.15 DTC Memory, Checking

- Follow these steps in sequential order.
 - ◆ Connect VAS 5051/5052
 - ◆ Vehicle Self-Diagnosis (OBD)
 - ◆ Gateway device list
 - ◆ Read the control module with the fault stored in the DTC memory.
 - ◆ Correct relevant malfunctions with customer's approval.

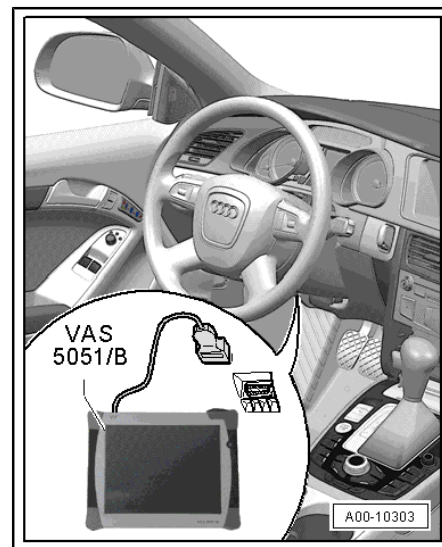

2.16 Engine Compartment Front Noise Insulation Cover, Removing and Installing

- Remove noise insulation -mounting pieces 1 through 4-

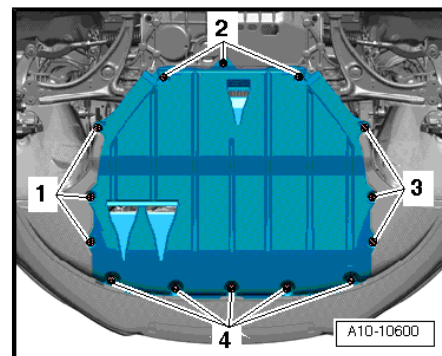

2.17 Coolant System, Checking

Note

- ◆ *The additional coolant portion of the mixture must amount to at least 40% (freeze protection to -13°F [-25°C]) and should not exceed 60% (freeze protection to -40°F [-40°C]). Otherwise the freeze protection will be reduced and the cooling efficiency will be worsened.*
- ◆ *The freeze protection must be ensured to approximately -13°F (-25 °C).*
- ◆ *Freeze protection, refer to the Electronic Parts Catalog.*

Special tools and workshop equipment required

- ◆ Refractometer -T10007-

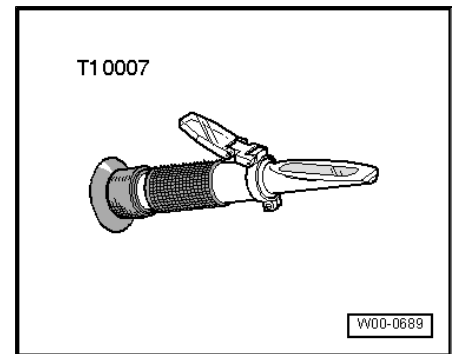

Note

Read the bright/dark boundary to obtain an accurate reading for the following tests. Place a drop of water on the glass to improve the readability of the bright/dark boundary. The bright/dark boundary can be clearly recognized on the "WATERLINE".

- Check the concentration of the coolant additive using - T10007- (operating instructions).

The scale -1- of the refractometer is designed for coolant additives G 12, G12 Plus, G12 Plus Plus and G11.

Scale -2- refers only to coolant additive G 13. (begins L80)

Note

- ◆ *The freeze protection must be ensured to approximately -13°F [-25°C].*
- ◆ *If climate conditions make greater freeze protection necessary, the amount of can be increased up to 60% (Freeze protection to approximately -40°F [-40°C]). Adding more coolant reduces the freeze protection and reduces the cooling efficiency.*

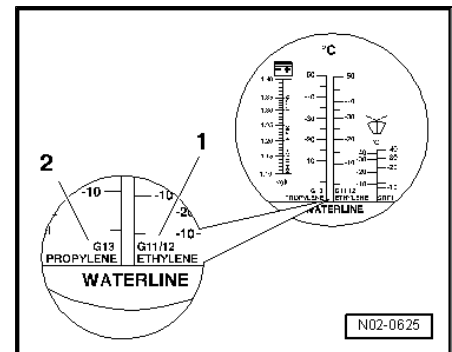

Coolant Level, Checking and Filling

- Check the coolant level in the reservoir when the engine is cold.

- ◆ Delivery inspection: Coolant level above the “MIN marking” -arrow-.
- ◆ Inspection service: Coolant level above the “MIN marking” -arrow-.
- If coolant level is too low, fill with coolant mixture.

i Note

Determine cause of fluid loss, which cannot be attributed to normal use and repair.

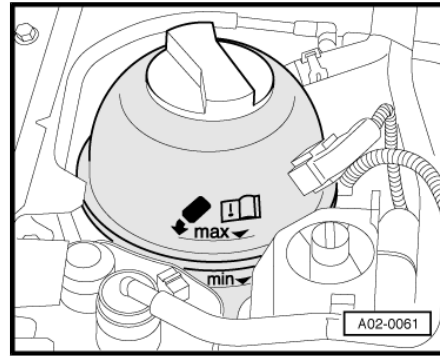

Mixture ratio:

Freeze protection to	Coolant additive	Water
-25°C (-13°F)	approximately. 40 %	approximately. 60 %
-35°C (-31°F)	approximately. 50 %	approximately. 50 %
-40°C (-40°F)	approximately. 60 %	approximately. 40 %

i Note

- ◆ *Coolant additive prevents freeze and corrosion damage, scaling, and raises the boiling point. For these reasons the cooling system must have coolant additive the whole year.*
- ◆ *Especially in countries with tropical climates or when vehicle is driven under heavy load, the coolant improves the engine reliability by its increased boiling point.*
- ◆ *The coolant concentration must not be reduced by adding water, even during the warmer season. The coolant additive ratio must be at least 40%.*

2.18 Instrument Cluster, Selecting Language

- Follow these steps in sequential order.
- ◆ Connect VAS 5051/5052
- ◆ Guided Fault Finding or Guided Functions
- ◆ Go to - function/component selection
- ◆ Service Work
- ◆ Language adaptation
- ◆ Now follow guided program



2.19 Air Filter, Cleaning Housing and Removing and Installing Filter

⇒ ["2.19.1 General Information", page 31](#)

⇒ ["2.19.2 6-Cylinder 3.2L MPI", page 31](#)

⇒ ["2.19.3 4-Cylinder 2.0 TFSI", page 32](#)

⇒ ["2.19.4 4-Cylinder 2.0 TFSI", page 34](#)

⇒ ["2.19.5 4-Cylinder, 2.0 TFSI", page 35](#)

⇒ ["2.19.6 5-Cylinder 2.5 TFSI", page 35](#)

2.19.1 General Information



Note

- ◆ *If the air filter insert is heavily soiled or soaked, dirt particles or moisture can reach the mass airflow sensor -G70- and cause an incorrect airflow reading. This causes lack of performance because a lower injection amount is calculated.*
- ◆ *Always use an original air filter insert.*
- ◆ *Use a lubricant (silicone-free) when installing intake hose.*
- ◆ *Secure all hose connections with hose clamps that match current standard production: refer to the Parts Catalog.*
- ◆ *Check drain hose in bottom side of air filter or dirt and adhesion (clean, if necessary).*
- ◆ *Clean air filter housing (upper and lower parts) of salt residue, dirt or leaves (clean with vacuum, if necessary).*
- ◆ *Check mass airflow sensor and intake hose (clean air side) for salt residue, dirt and leaves.*
- ◆ *Check the intake canal up to the filter insert for dirt.*
- ◆ *When installing air filter insert, ensure it is centered in mount on bottom of air filter.*
- ◆ *Carefully and gently place upper part of air filter on lower part. When doing so, ensure upper part of air filter is not crooked on air filter insert. Pay attention to the seal lip on the air filter insert (air leak).*
- ◆ *Finally, screw upper part of air filter onto lower part.*

2.19.2 6-Cylinder 3.2L MPI

- Open hose clamps -2- with Hose Clip Pliers -V.A.G 1921- and remove intake hose -1-.
- Release the connector -3- from the mass airflow sensor and remove.
- Remove fastening bolts -arrows-.
- Lift and remove the air filter housing upper section.

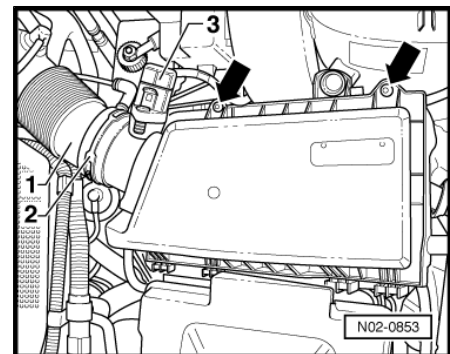

- Remove old air filter -arrow-.
- Clean filter housing and insert new air filter.

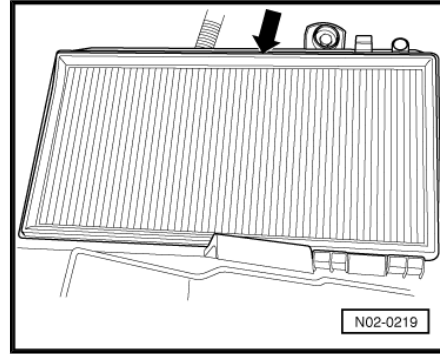

- Install the air filter housing upper section and tighten the screws.
- Connect the connector -3- for the mass airflow sensor and secure.
- Attach the air intake tube -1- to the filter housing and secure with hose clamp -2-.

Follow all general information, refer to
⇒ ["2.19.1 General Information", page 31](#)

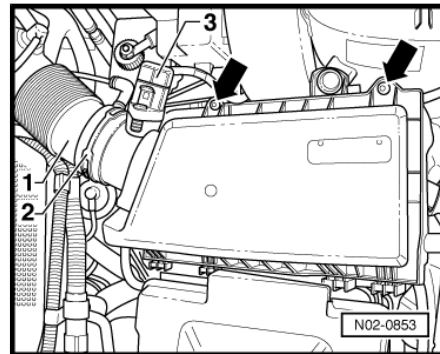

2.19.3 4-Cylinder 2.0 TFSI

Special tools and workshop equipment required

- ◆ Spring Type Clip Pliers -VAS 5024A-

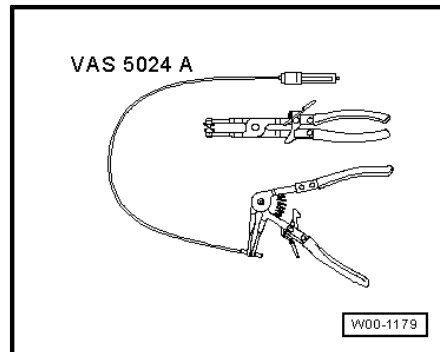

- Disconnect electrical connector -3- on Mass Air Flow Sensor -G70- .

- Open the clamps -1 and 2- and disconnect the air guide hose from the mass airflow sensor.
- Disconnect the intake hose -arrows-.
- Open the spring clamps -4- and disconnect the air intake hose from the engine cover.

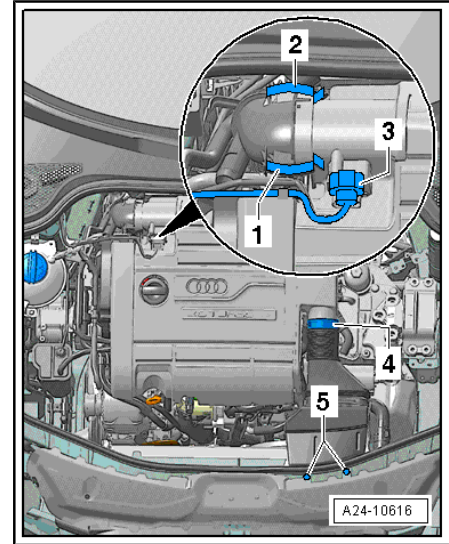

- Carefully pull the engine cover off positions -1 - 2 - 3 - 4- one after the other.



Caution

Always follow the sequence otherwise the engine cover may break.

- Cover the open intake hose with a clean cloth.

Removing Air Filter Insert

- Remove all the screws -arrows-.

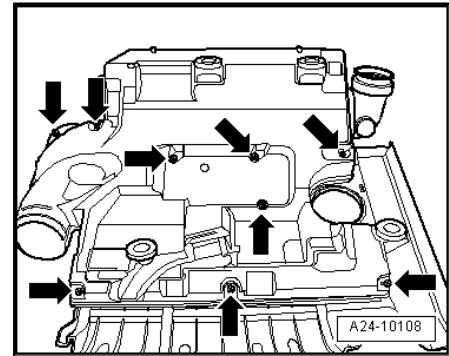
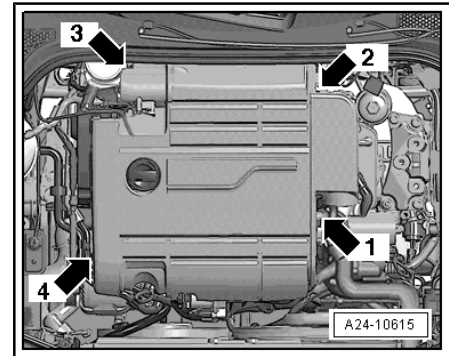

- Remove the engine cover from the retainers -arrows-.

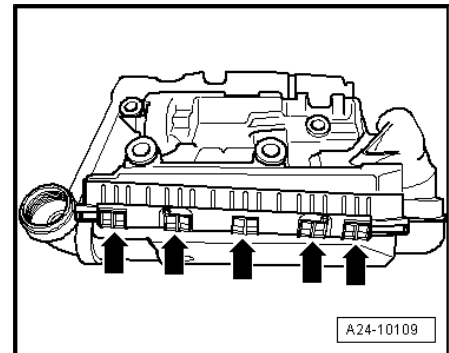

- Remove the air filter from the engine cover.
- Clean filter housing and insert new air filter.

i Note

- ◆ *Self-locking bolts are equipped for fastening the air filter upper section to the air filter housing lower section. If these bolts are loosened or tightened with a drill motor, the threads in the air filter housing upper section can be damaged.*
- ◆ *For this reason, a drill motor may only be used when the following prerequisites are met:*
- ◆ *The drill motor RPM is max. 200 / min.*
- ◆ *The torque must be adjustable to max. 3 Nm.*
- ◆ *When installing, place engine compartment cover on four mounting points and press them down at the same time with the hand held flat.*
- ◆ *When installing, ensure rubber grommets are seated cleanly between air filter housing and intake tube.*

- Assembly is done in reverse order

Follow all general information, refer to
⇒ **"2.19.1 General Information", page 31**

2.19.4 4-Cylinder 2.0 TFSI

Removing

- Remove the air guide hose -1- from the mass air flow sensor -G70- .
- Disconnect electrical connector -2- from Mass Air Flow Sensor -G70- .
- Remove the air filter housing upper section -arrows- and remove the air filter.

Installing

Installation is reverse of removal, but note the following:

For proper mass air flow sensor function, it is important to observe the following notes and perform the procedure exactly.

i Note

- ◆ *If the air filter insert is heavily soiled or soaked, dirt particles or moisture can reach the Mass Air Flow Sensor and cause an incorrect airflow reading. This causes lack of performance because a lower injection amount is calculated.*
- ◆ *Always use an original air filter insert.*
- ◆ *The air filter housing must be clean.*
- ◆ *Secure all hose connections with hose clamps that match current standard production. Refer to Electronic Parts Catalog.*
- ◆ *When cleaning the air filter housing using compressed air, note the following: to avoid malfunctions, cover the critical air distribution components such as the mass air flow sensor, air guide tubes etc. with a clean cloth.*
- ◆ *Follow all waste disposal regulations!*

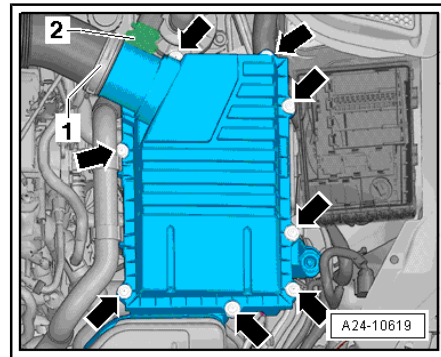
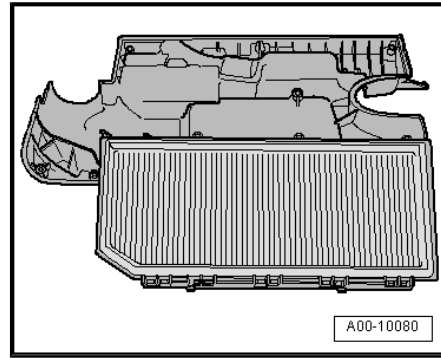

- Clean the water drain (small hole in the air filter housing lower section) with compressed air.
- Clean air filter housing (upper and lower parts) of salt residue, dirt or leaves (clean with vacuum, if necessary).
- Check mass airflow sensor and air guide hose (clean air side) for salt residue, dirt and leaves.
- Check air duct from lock carrier to air filter housing for dirt and leaves.
- When installing air filter insert, ensure it is centered in mount on bottom of air filter.
- Carefully and gently place upper part of air filter on lower part. Make sure the air filter housing upper section is not sitting crooked on air filter (pay attention to the air filter sealing lip).
- Make sure the air guide hose is seated firmly on mass airflow sensor.

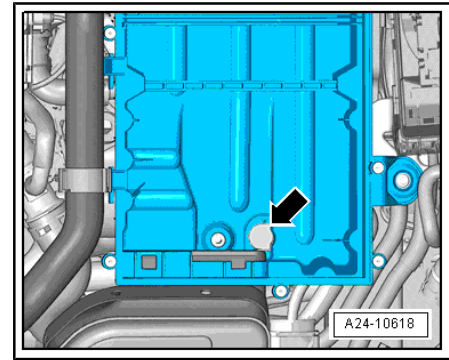

Tightening Specifications	Nm
Air filter housing upper section	5

Follow all general information, refer to [⇒ "2.19.1 General Information", page 31](#)

2.19.5 4-Cylinder, 2.0 TFSI

- Loosen bolts -arrows- and raise cover.
- Remove the old air filter.
- Clean the filter housing and insert a new air filter.
- Remove the old air filter.
- Clean the filter housing and insert a new air filter.

Follow all general information, refer to [⇒ "2.19.1 General Information", page 31](#)

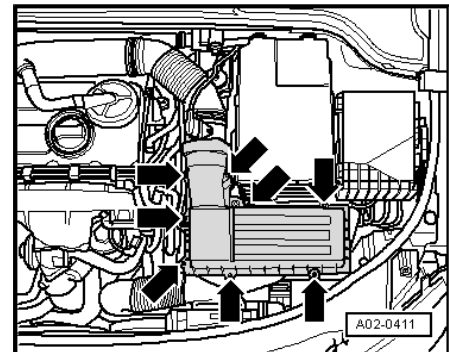

2.19.6 5-Cylinder 2.5 TFSI

Removing

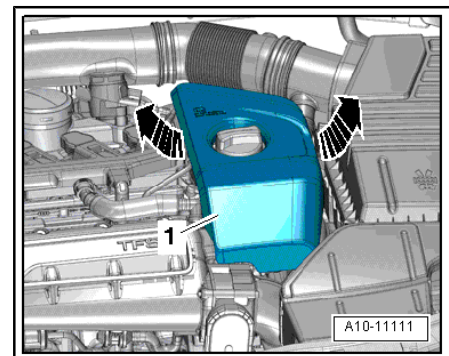

- Remove the engine cover -1- upwards -arrows-.

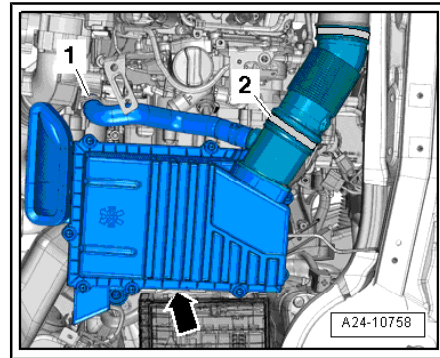

- Loosen the hose clamps -1- and -2-.
- Remove the screws -arrows- and remove the air filter housing upper section.
- Remove air filter insert.

Installing

Installation is reverse of removal, but note the following:

For proper mass airflow sensor function, it is important to observe the following notes and perform the procedure exactly.

Note

- ◆ *If the air filter insert is heavily soiled or soaked, dirt particles or moisture can reach the Mass Air Flow Sensor and cause an incorrect airflow reading. This causes lack of performance because a lower injection amount is calculated.*
- ◆ *Always use an original air filter insert.*
- ◆ *The air filter housing must be clean.*
- ◆ *Secure all hose connections with hose clamps that match current standard production, refer to Electronic Parts Catalog.*
- ◆ *When cleaning the air filter housing using compressed air, note the following: to avoid malfunctions, cover the critical air distribution components such as the mass airflow sensor, air guide tubes etc. with a clean cloth.*
- ◆ *Follow all waste disposal regulations!*

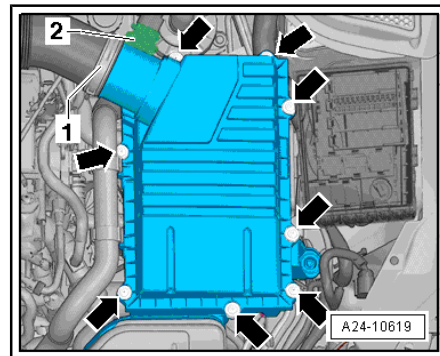

- Clean the water drain (small hole in the air filter housing lower section) with compressed air.
- Clean air filter housing (upper and lower parts) of salt residue, dirt or leaves (clean with vacuum, if necessary).
- Check mass airflow sensor and air guide hose (clean air side) for salt residue, dirt and leaves.
- Check air duct from lock carrier to air filter housing for dirt and leaves.
- When installing air filter insert, ensure it is centered in mount on bottom of air filter.
- Carefully and gently place upper part of air filter on lower part. Make sure the air filter housing upper section is not sitting crooked on air filter (pay attention to the air filter sealing lip).
- Make sure the air guide hose is seated firmly on mass airflow sensor.

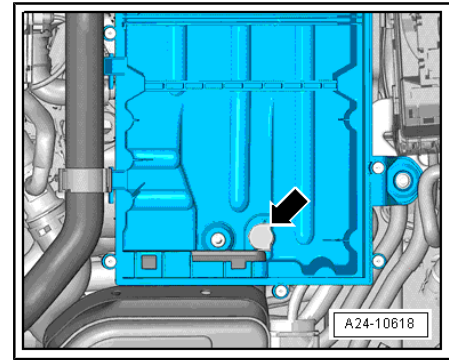

Tightening Specifications	Nm
Air filter housing upper section	5

Follow all general information, refer to ⇒ "2.19.1 General Information", page 31

2.20 Haldex Clutch Oil, Changing

- Replace oil. Refer to ⇒ Rear Final Drive 02D, 0AV, 0BR, 0BS, 0BY; Rep. Gr. 39 ; General Information

2.21 Hood Safety Catch, Lubricating

- Perform the following steps in the given sequence:

Note

- ◆ *Vehicle must be at least at room temperature.*
- ◆ *Operate the moveable components several times to allow the universal oil to seep in.*
- ◆ *Remove any excess lubricant with a lint-free cloth.*

Lubricating

- Coat the hood safety catches with universal oil-Spray G 000 115 A2 at the marked positions -arrows-.

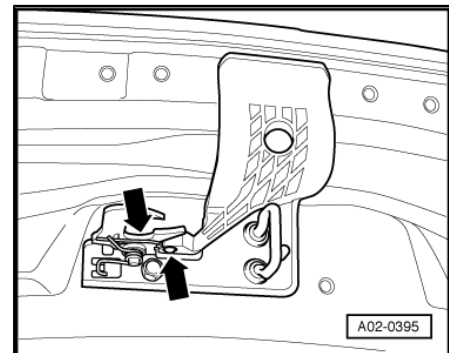

2.22 Engine Cover, Removing

Special tools and workshop equipment required

- ◆ Hose Clip Pliers -VAS 6340-

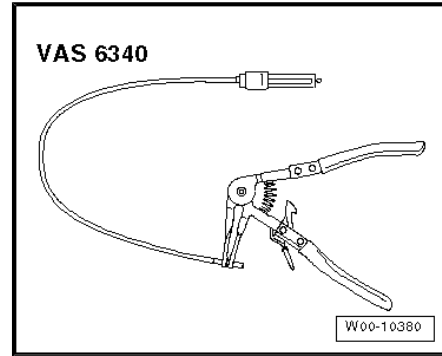

4-Cylinder -gasoline engine 2.0L (TFSI)

- Relieve load on clamps at Mass Air Flow (MAF) sensor -A- and at air intake connection -B- using pliers for spring type clamps -VAS 6340- and slide them back.

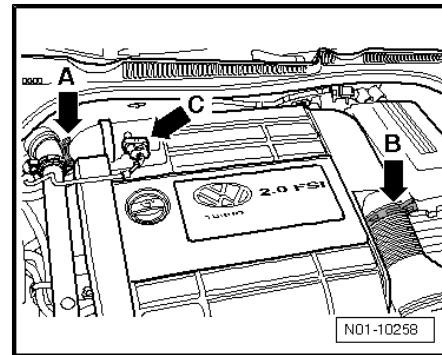

- Disconnect the mass airflow sensor -2- and move the connector to the side.
- First pull engine cover forward -3 arrows- and then back -4 arrow-.
- To do this, grab under the cover at the sides.

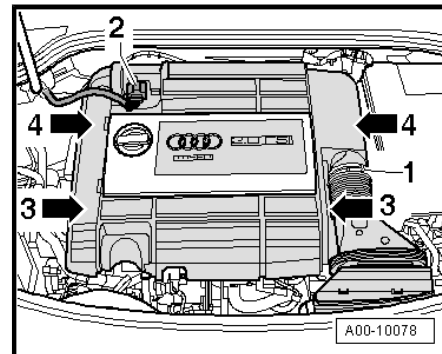

Note

- ◆ *When installing, place engine cover on four mounting points and press them down at the same time with the hand held flat.*
- ◆ *When installing, ensure rubber grommets are seated cleanly between air filter housing and intake tube.*

4-Cylinder -gasoline engine 2.0L TFSI

Removing

- Remove the engine cover -arrows-. Do not jerk the engine cover or pull it off from one side.

Installing

- Carefully press the engine cover back into the catches.
- To avoid damage, do not hit engine cover with fist or a tool.

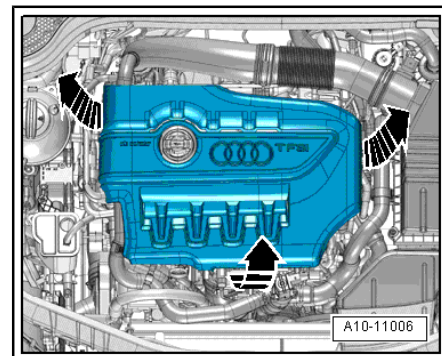

4-Cylinder -gasoline engine 1.8 TFSI, 2.0 TFSI:

- Remove the engine cover-arrows-.

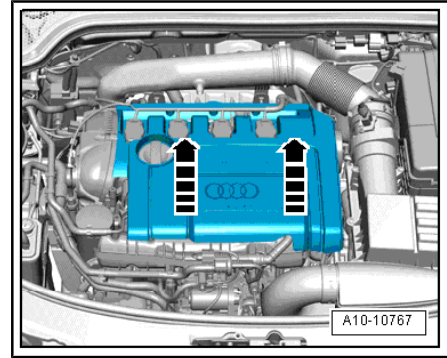

5-Cylinder -gasoline engine 2.5.0L TFSI:

- Remove the engine cover -1- upwards -arrows-.

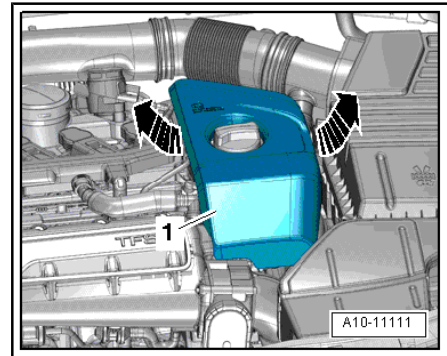

4-Cylinder CR TDI Engine:

- Remove the engine cover-arrows-.

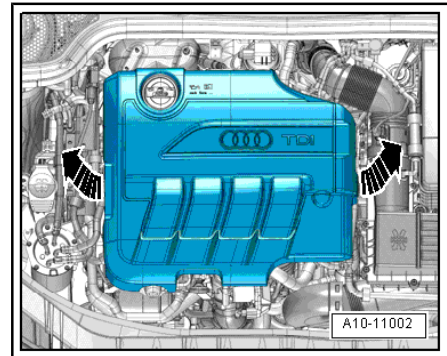

2.23 Engine and Engine Compartment from Underneath, Inspecting for Leaks and Damage

- Perform visual check as follows:
- Check engine and transmission for leaks and damage.
- Check the final drive, CV boots and steering for leaks and damage.



WARNING

Eliminate any malfunctions (repair procedure).

2.24 Engine Oil, Draining/Extracting and Removing and Installing Filter

⇒ "2.24.1 General Information", page 40

⇒ "2.24.2 4-Cylinder, Gasoline Engine, 1.8 TFSI, 2.0 TFSI", page 41

⇒ "2.24.3 4-Cylinder, Gasoline Engine, 2.0 TFSI, 2.5 TFSI", page 41

⇒ "2.24.4 6-Cylinder 3.2L MPI", page 42

2.24.1 General Information



WARNING

Oil extraction not permitted with various engine types! See maintenance table.



Note

Perform oil change at operating temperature.

Special tools and workshop equipment required

◆ Oil extractor -V.A.G 1782-

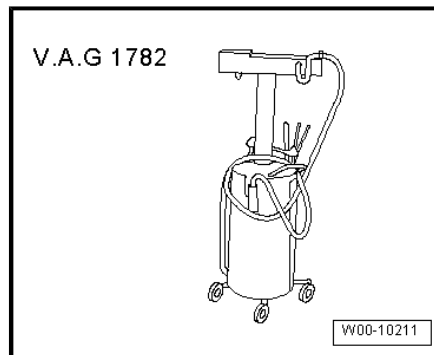

◆ Hazet tension band -2171-1-

◆ Oil filter wrench -3417-

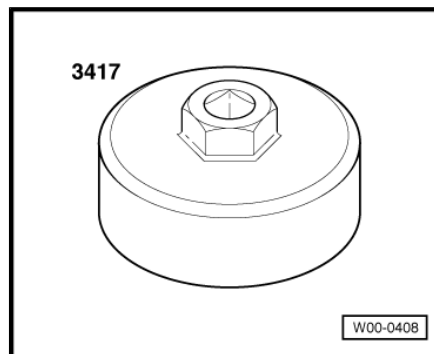

- ◆ Oil drain adapter -T 40057-

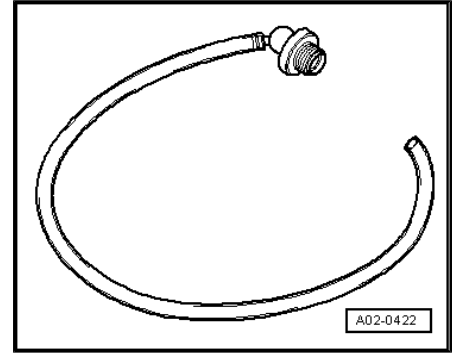

 **Note**

Follow all waste disposal regulations!

2.24.2 4-Cylinder, Gasoline Engine, 1.8 TFSI, 2.0 TFSI

- Remove the noise insulation. Refer to [⇒ "2.16 Engine Compartment Front Noise Insulation Cover, Removing and Installing", page 28](#) .
- Loosen oil filter with Hazet Tension Band -2171-1- or Oil Filter Wrench -3417- and remove.

 **Note**

Follow all waste disposal regulations!

- Open oil drain plug or extract engine oil.
- Clean oil filter sealing surface on engine.
- Lubricate rubber seal lightly with oil.
- Install new filter and tighten.
- Install oil drain plug with new gasket.
- Fill with engine oil, specifications, refer to ⇒ Fluid Capacity Tables; Rep. Gr. 03 .

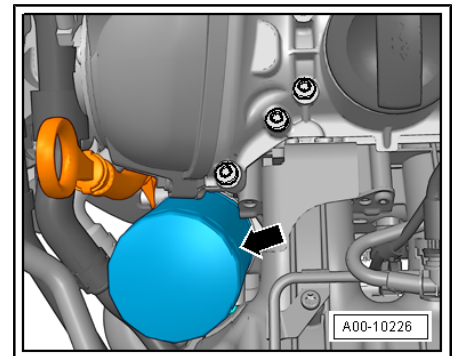

Tightening Specifications	Nm
Oil filter	22
Oil drain plug	30

2.24.3 4-Cylinder, Gasoline Engine, 2.0 TFSI, 2.5 TFSI

- Remove the noise insulation. Refer to [⇒ "2.16 Engine Compartment Front Noise Insulation Cover, Removing and Installing", page 28](#) .

 **Note**

Before removing oil filter, motor oil must be drained from filter so that it does not drain onto engine and attached parts.

- Remove bottom valve protective cap -1-.
- Remove ball head hose from Oil Drain Adapter -T 40057- and turn threaded bolt in bottom oil filter housing bottom valve -2- under a slight resistance is felt.
- Now place ball head hose on threaded bolts and turn Oil Drain Adapter -T 40057- to stop - a clear snap of the drain valve will be heard.
- Allow oil filter to run empty.



WARNING
Hot engine oil

- Open oil drain plug or extract engine oil.
- Remove Oil Drain Adapter -T 40057- .
- Check whether bottom valve -1- is flush and not crooked, as in illustration (A02-0423).
- Remove protective cap.
- Open oil filter housing -2- with Oil Filter Wrench -3417- or with socket AF 36, e.g. Socket AF 36 -T10125- and remove oil filter.

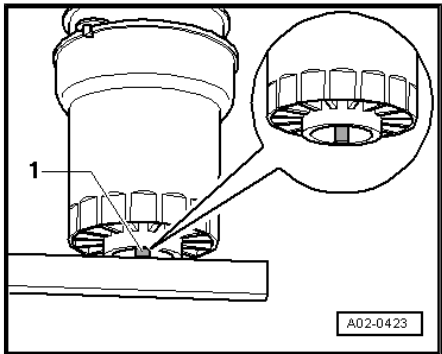
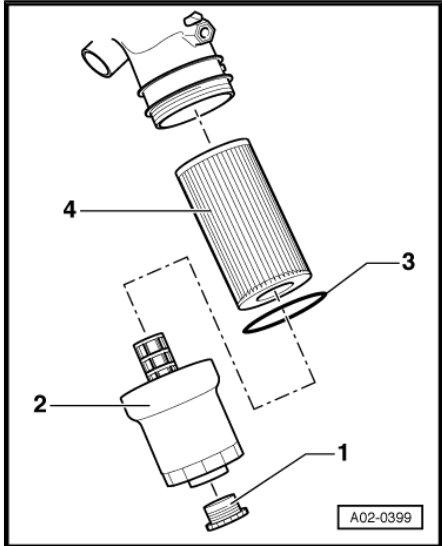

- Replace filter insert -4- and gasket -3-.

 **Note**

- ◆ Note the position of the service flag on the seal -arrow-.
- ◆ Follow all waste disposal regulations!

- Clean sealing surface on oil filter housing.
- Lubricate rubber seal lightly with oil.
- Smooth side of sealing ring must face toward outside
- Screw on filter housing and tighten.
- Install oil drain plug with new gasket.
- Fill with engine oil, specifications, refer to ⇒ Fluid Capacity Tables; Rep. Gr. 03 .

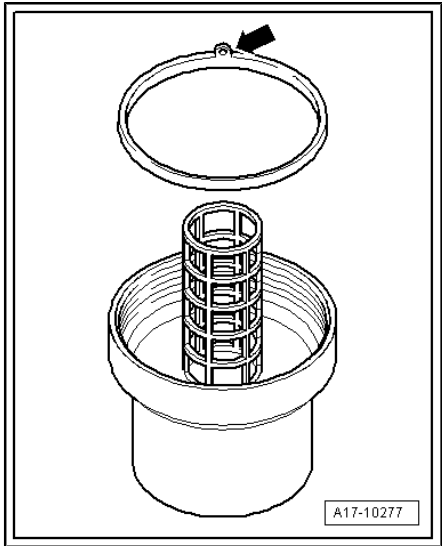

Tightening Specifications	Nm
Oil filter	25+5
Oil drain plug	30

2.24.4 6-Cylinder 3.2L MPI

- To drain oil, remove noise insulation on drain plug. Refer to ⇒ ["2.16 Engine Compartment Front Noise Insulation Cover, Removing and Installing", page 28](#) .

- Remove oil drain plug -1- and drain oil.

 **Note**

Follow all waste disposal regulations!

- Loosen lower portion of filter housing -3- at the hex -2- or circumference -4- and remove.
- Remove the old air filter.
- Thoroughly wipe oil filter housing with a shop cloth.
- Remove old O-ring.
- Take new O-ring and coat with engine oil.
- Install new filter element and O-ring.
- Tighten the filter housing lower section -3- at the hex bolt -2- to 30 Nm.
- Install the oil drain plug -1- with a new seal and tighten to 10 Nm.

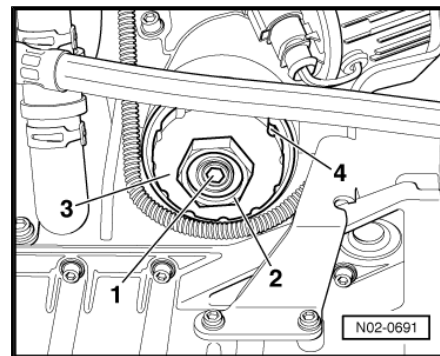

Tightening Specifications	Nm
Oil drain plug	30

- Fill with engine oil, specifications, refer to ⇒ Fluid Capacity Tables; Rep. Gr. 03 .

2.25 Hood Hinge, Lubricating

- Lubricate the hood hinge joint with a universal lubricant spray G 000 115 A2.

2.26 Engine Oil, Filling

 **Note**

Oil capacities, oil specifications and viscosity class. Refer to ⇒ Fluid Capacity Tables; Rep. Gr. 03 .

Engines with a turbocharger

- After the engine oil and oil filter have been replaced, observe the following when first starting the engine:
 - ◆ As long as the oil pressure indicator lamp in the instrument cluster is on, the engine may only run in idle. Do not touch the accelerator pedal! Bumping the accelerator pedal can damage the turbocharger or destroy it completely
 - ◆ When the indicator lamp goes out, this means the oil pressure has been reached. Then you may accelerate.

All:

- Check the oil level. Refer to ⇒ ["2.27 Engine Oil Level, Checking", page 44](#) .

2.27 Engine Oil Level, Checking

Note

- ◆ *Minimum engine oil temperature 140°F (60°C).*
 - ◆ *Vehicle must be in level position.*
 - ◆ *After stopping engine, wait a few minutes to allow oil to flow back into oil pan.*
 - ◆ *Follow all waste disposal regulations!*
- Pull out oil dipstick and wipe with clean rag. Replace dipstick and push down to stop.
 - Pull out dipstick again and read oil level.
- A - Oil must not be topped off.
B - Add oil.
C - Add oil.
- The oil level should be located in the marked area -arrow-.



Caution

Damage to the catalytic converter can occur if the oil level is above the -A- range.

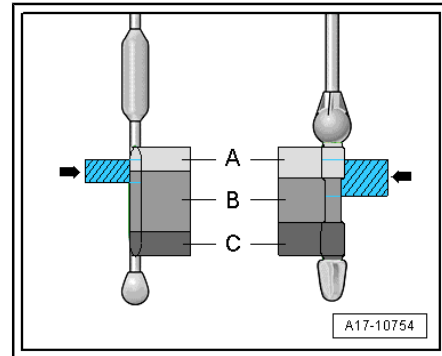

2.28 Navigation Eject Button, Unlocking

- Follow these steps in sequential order.
- ◆ Connect VAS 5051/5052
- ◆ Guided Functions
- ◆ Go to - function/component selection
- ◆ Service Work
- ◆ J401 - Navigation, Eject button, locking/unlocking
- ◆ Now follow guided program



2.29 Radio, Entering Security Code to Activate Anti-Theft Coding

Radios are supplied having a fixed code. The security code means that every radio with anti-theft coding is programmed with its own code. This code is not active from the factory. To increase anti-theft protection, there is no longer a radio card in the radio

and navigation system owner's manual. The entry of the radio code is no longer described in the owner's manual.

The Anti-theft coding on a unit that is ready to play is activated by entering the fixed code.

On chorus II+, concert II+ and symphony II+ radios, enter the radio code as follows:

- Switch on radio. "Code 1000" appears.
- Press the upper left control button "X__" -arrow- until the first digit of the radio code appears in the display.
- Enter remaining three radio code digits with other three control buttons
- Press the "ENTER" button. The radio is coded.
- Dispose of sticker with radio code.

If the radio code is entered incorrectly two times and "Code Safe 2" appeared in the display, use the following procedure

Leave radio switched on approximately 60 minutes. After 60 minutes, "Code Safe / Code 1000" appears in the display and the radio is switched off.

Enter radio code again.

On navigation system BNS 5.0, enter radio code as follows

- Switch on navigation system
- Enter PIN using Speller
- Confirm entry with "OK".
- Dispose of sticker with radio code.

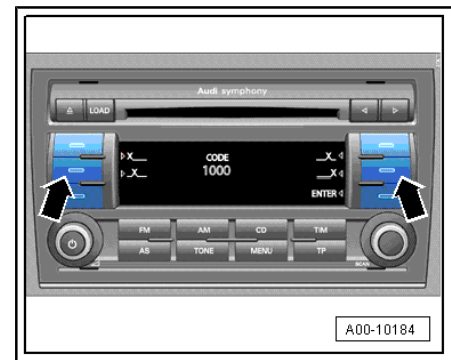

 **Note**

- ◆ *Please inform the customer that he can only learn the anti-theft radio code from the service advisor*
- ◆ *That way, thieves really cannot use the radio!*

2.30 Road Test

The following checks depend on the vehicle equipment level and the available testing possibilities (city or rural).

- During the road test, check the following:
 - ◆ Engine: performance, stalling, idle, acceleration
 - ◆ Clutch: starting, pedal force, smell
 - ◆ Shifting: ease of movement, shift lever position
 - ◆ Automatic transmission: selector lever position, shift lock/ignition key interlock, shift behavior, instrument cluster display
 - ◆ Foot and parking brake: function, free travel and effectiveness, pulling to one side, rubbing, squeaking
 - ◆ ABS function: when braking with activated ABS, the brake pedal must pulse noticeably.
 - ◆ Steering: function, steering travel, steering wheel center position when driving straight ahead.
 - ◆ Tilt/slide sunroof: function

- ◆ Cruise control system: function
- ◆ Radio: reception, interference
- ◆ Driver information system (DIS): functions
- ◆ A/C system: function
- ◆ Vehicle: pulling to one side while driving straight ahead (level road)
- ◆ Imbalance: wheels, driveshafts
- ◆ Wheel bearing: noises
- ◆ Engine: warm starting behavior
- ◆ Check the horn

2.31 Wheel Bolts, Tightening Specifications

The adapter to loosen/tighten the anti-theft wheel bolts is located with the vehicle tool kit.

Note

Be sure to tighten wheel bolts in diagonal sequence to the following specified torque:

Tightening Specifications	Nm
Wheel Bolts	120

- Place the adapter and extractor back in the vehicle tool kit.

2.32 Tire Pressure Monitoring Display, Adapting

Note

After each change involving the tires, e.g. tire pressure or replacing or exchanging tires, the system must be programmed.

- With ignition on and vehicle standing, press tire pressure monitoring button -arrow- until tire pressure display blinks several times in instrument cluster and a signal is heard.
- Once the signal is heard, the TPMS has been adapted.

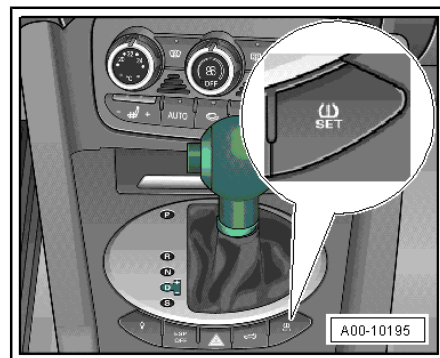

2.33 Windshield Washer System, Checking and Adjusting Spray Nozzles

Special tools and workshop equipment required

- ◆ Setting tool -T10127- equipped with Tip -3125/5A-

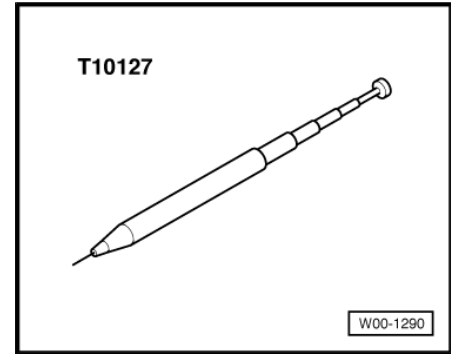

- ◆ or
- ◆ Setting tool -T40187- equipped with Tip -3125/5A-

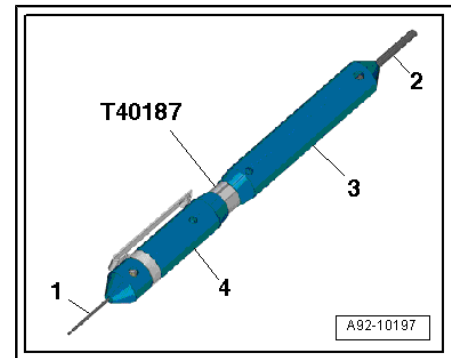

WARNING

Danger of personal injury.

- ◆ *If the wiper spray nozzle adjusting tool -T40187- is not going to be used, then make sure both sides are covered and locked with the covers -3- and -4-.*
- ◆ *If one side is not locked by the cover, it is possible to get injured by the needle -3125/5A- -1- or by the adjusting pin -2-.*
- ◆ *When opening a side make sure the opposite side is not facing the hand.*

- Unlock the long cover -1- on the spray nozzle adjusting tool -T40187- -arrow A- and push it toward the rear -arrow B-.

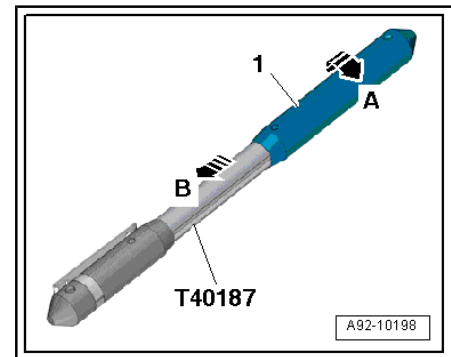

- Install the adjusting pin -2- on the spray nozzle -arrow- in the nozzle unit -1- and aim it at the windshield. Adjust it if necessary.
- If the spray field does not match the specifications, clean uncleaned washer nozzles.

⚠ WARNING
Danger of personal injury.
 ♦ *The cover must cover and lock the adjusting pin after each use.*

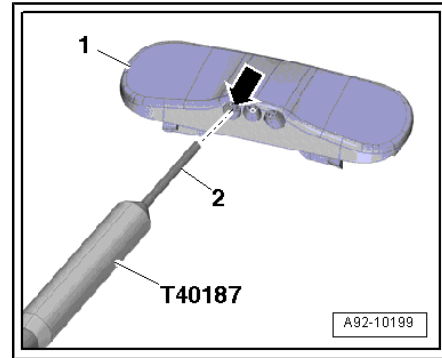

i Note

Never use a needle or a similar object, since it may damage the water hoses in the spray nozzle!

Setting

i Note

The adjustment dimensions give values for a driving vehicle, that is, when parked, the spray pattern will shift slightly.

- Mark the 6 points on the windshield with a water-soluble pen:

Dimensions in mm	Driver's side	Passenger side
-a- =	300	300
-b- =	600	600
-c- =	320	320
-d- =	335	335
-e- =	495	495
-f- =	175	175

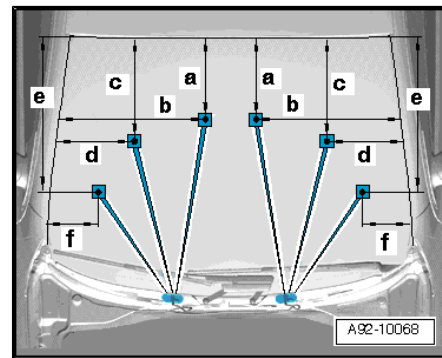

- Locate the points of the individual spray jets with the Windshield Washer Aiming Tool -T10127- .
- If the spray field does not match the specifications, clean uncleaned washer jets.

Cleaning washer nozzles:

- Remove washer nozzle. Refer to => Electrical Equipment; Rep. Gr. 92 ; Removal and Installation
- Flush washer jet in the opposite direction of the spray flow with clean water.
- To remove the rest of the contaminants, the washer jet may only be cleared with compressed air blowing opposite the direction of the spray.
- If the spray field still does not correspond to the specifications, replace the washer jet.

2.34 Headlamp Washer System, Checking Spray Nozzles

Headlamp cleaner spray nozzles are set at the factory and do not need to be adjusted.

2.35 Windshield Wiper Blades, Checking End Position and for Damage

Windshield Wiper Blade Park Position



Note

- ◆ *Every second time it is switched off, the wiper motor runs to an over-stroke parked position, that ensures that the lip of the wiper blade is flipped to the other direction.*
- ◆ *For this to happen, the wiper motor runs downward to the end position and then back up again very slightly. This over-stroke parked position must not be used for aligning/checking the wiper crank.*
- ◆ *The position where the wiper motor runs directly to end position must be used. Activate mist wipe again, if necessary.*
- Switch windshield wipers on and off and allow to run to end position.
- Turn the ignition off.
- Check if the windshield wiper blade tips are positioned with the following distances to the plenum chamber cowl panel grille at the bottom of the windshield:
 - ◆ Dimension -a- = 5 mm +10 mm
 - ◆ Dimension -b- = 24 mm + 10
- Adjust the wiper arm if necessary. Refer to ⇒ Electrical Equipment; Rep. Gr. 92 ; Removal and Installation



Note

The dimensions give the distance of the wiper blade point to the black cowl panel on lower edge of windshield. Placement is similar for RHD vehicles.

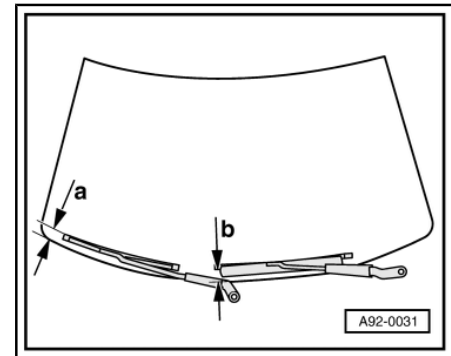

2.36 Service Display, Resetting or Adapting

⇒ ["2.36.1 Service Interval Display, through MY 2007, Resetting", page 49](#)

⇒ ["2.36.2 Service Interval Display, from MY 2008, Resetting", page 50](#)

⇒ ["2.36.3 Oil Quality, Adapting", page 50](#)

⇒ ["2.36.4 Maximum Values, Adapting", page 51](#)

⇒ ["2.36.5 Service Display, Resetting after Service without VAS 5051/5052", page 52](#)

2.36.1 Service Interval Display, through MY 2007, Resetting

- Follow these steps in sequential order.

- ◆ Connect VAS 5051/5052
- ◆ Guided Fault Finding or Guided Functions
- ◆ Go to - function/component selection
- ◆ Service Work
- ◆ Combination Processor, reset WIV
- ◆ Now follow guided program

 **Note**

- ◆ *Please follow guided program function description*
- ◆ *WIV = Wartungsintervall - Verlängerung (Maintenance Interval Extension)*



2.36.2 Service Interval Display, from MY 2008, Resetting

 **Note**

From MY 2008, all vehicles are equipped with the new maintenance concept as in the A5

- Follow these steps in sequential order.
- ◆ Connect VAS 5051/5052
- ◆ Guided Functions
- ◆ Service Work
- ◆ Now follow guided program

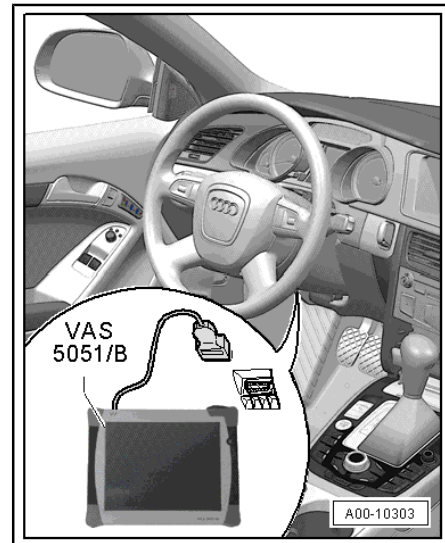

2.36.3 Oil Quality, Adapting

- Follow these steps in sequential order.

- ◆ Connect VAS 5051/5052
- ◆ Use auxiliary K-lead adapter VAS 6017B
- ◆ Guided Fault Finding or Guided Functions
- ◆ Go to - function/component selection
- ◆ Service Work
- ◆ Combination Processor, changing oil quality
- ◆ Now follow guided program

 **Note**

- ◆ *It is necessary to change oil quality if changed between inspection or LongLife Service.*
- ◆ *Inspection Service = Oil quality 1*
- ◆ *LongLife Service = Oil quality 2*
- ◆ *WIV = Wartungsintervall - Verlängerung (Maintenance Interval Extension)*
- ◆ *Please follow guided program function description*

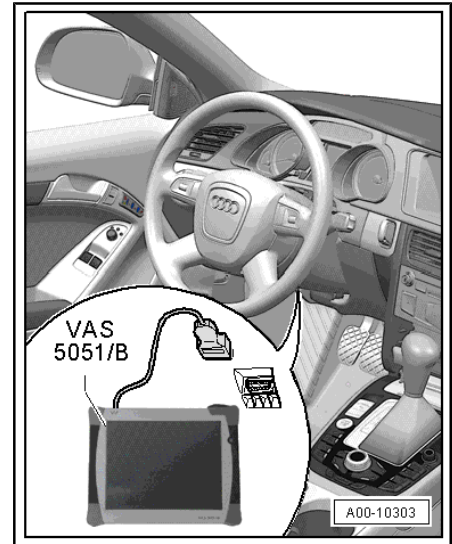

2.36.4 Maximum Values, Adapting

 **Note**

Applies only through MY 2007

- Follow these steps in sequential order.
- ◆ Connect VAS 5051/5052
- ◆ Guided Fault Finding or Guided Functions
- ◆ Go to - function/component selection
- ◆ Service Work
- ◆ Combination Processor, adjusting maximum WIV value
- ◆ Now follow guided program

Maximum values at inspection service

Minimum mileage in miles (Km)	10,000 miles (15,000 km)
Maximum mileage in miles (Km)	10,000 miles (15,000 km)
Maximum time interval in days	365



 **Note**

- ◆ *WIV = Wartungsintervall - Verlängerung (Maintenance Interval Extension)*
- ◆ *Please follow guided program function description*

2.36.5 Service Display, Resetting after Service without VAS 5051/5052

Note

If the service display is reset manually via the instrument cluster, it automatically sets itself to fixed interval.

- Switch the ignition on.
- With button 1 pressed, the message "SERVICE" appears.
- Pull the knob one more time within 5 seconds until "SERVICE IN KM... DAYS appears."
- Service has been reset.

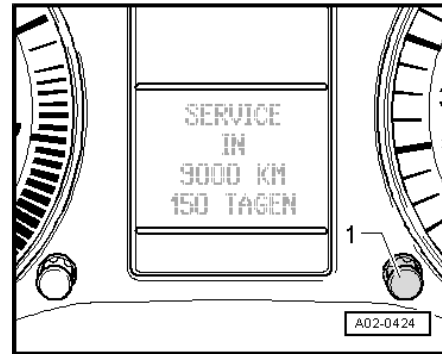

2.37 Install Fuse for Headlamp Washer System

- Headlamp washer system fuse: 30 amp fuse is installed in fuse panel 1, location 1 in the E-box in the engine compartment.
- Insert it in fuse holder 1 slot number 6 in the engine compartment E-box

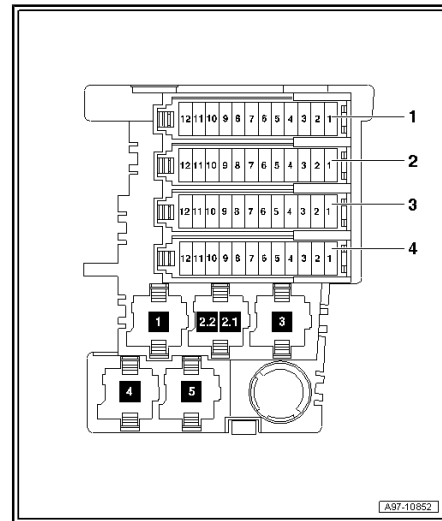

2.38 Dust and Pollen Filter, Removing and Installing

 **Note**

- ◆ *The dust and pollen filter is available in different versions without and with a filter inserter in activated charcoal. Refer to Parts Catalog. Audi TT, which have A/C system, a dust and pollen filter with filter insert with activated charcoal is installed at this time.*
- ◆ *Clean dust and pollen filter area in A/C duct before installing a new filter.*
- ◆ *On vehicles with driver training equipment, you must remove the driver training pedals if necessary (depending on version, there are service separation points on the training pedals for driver training equipment)*

- Remove the screws -A- and remove the insulation -B-.
- Cover floor covering in area under dust and pollen filter with paper.

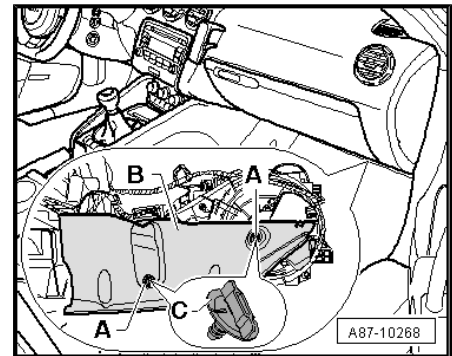

- Push cover -B- in direction of arrow -C- and remove cover.

 **Note**

If the retainers -D- can no longer hold the cover -B-, it can be secured with screws -A-.

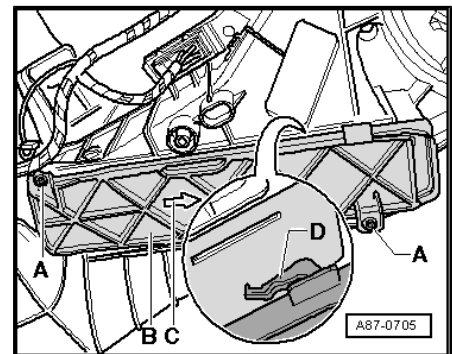

- Remove dust and pollen filter -A- from A/C unit shaft -B-.
- Clean A/C unit over shaft -B- (e.g. with a vacuum) after removing dust and pollen filter.

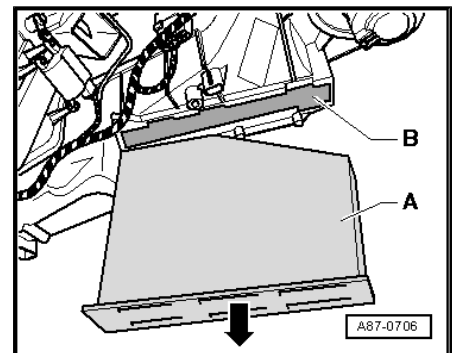

2.39 Tie Rods, Control Arms, Ball Joint and Driveshafts, Checking Play, Fit and Sealing Boots

Note

This test must be performed with vehicle raised (wheels hanging).

- Check play by moving tie rods and wheels.
- ◆ There must not be any play.

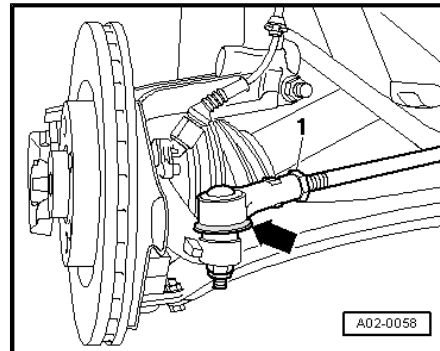

- Check joint boots -arrow- for damage and proper seating.
- Check joint boots -arrow- for damage and proper seating.
- Also check rear side of joint boots with a mirror.
- Check the play on the supporting joints -arrow-

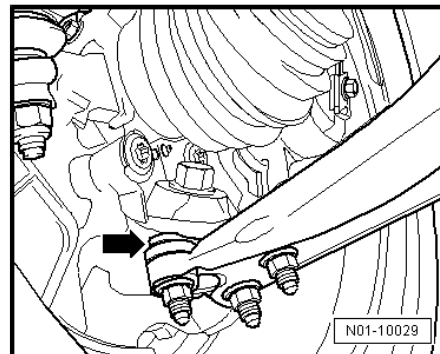

- Check the drive shaft boots.
- Check the sealing boot on the steering gear -arrow 1- for damage.

Note

Ignore arrows -2- and -3-

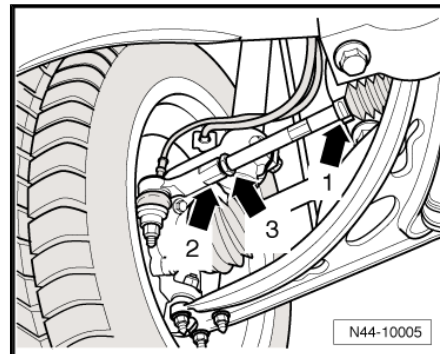

2.40 Transport Mode, Deactivating using VAS 5051/5052

Transport mode is for maintaining a vehicle's startability (battery charge). Transport mode limits discharging of battery. If transport mode is activated, many functions are not available or have limited function, for example, CD changer is deactivated, radio is deactivated, etc.

Switch off the transportation mode using Guided Fault Finding or Guided Functions.

- Follow these steps in sequential order.
- ◆ Connect VAS 5051/5052
- ◆ Vehicle Self-Diagnosis (OBD)
- ◆ Collected services
- ◆ Energy manager, deactivate transport mode

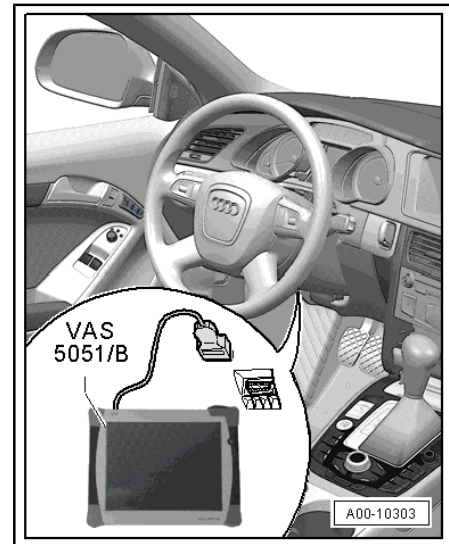

2.41 Door Arrester, Door Hinge and Lock Cylinder, Lubricating

- Perform the following steps in the given sequence:

 **Note**

- ◆ *Vehicle must be at least at room temperature.*
- ◆ *Operate the moveable components several times to allow the universal oil or spray lubricant to seep in.*
- ◆ *Remove any excess lubricant with a lint-free cloth.*

Door Arrester

- Remove the protective cap -1- in the direction of the arrow.
- Lubricate the door arrester on the marked positions -arrows-.
- Use universal oil spray G 000 115 A2.

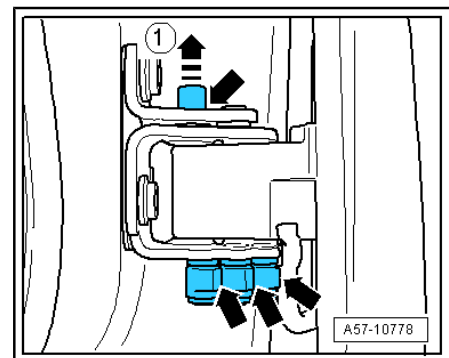

Door Hinge

- Lubricate the door hinge on the marked positions -arrows-.
- Use universal oil spray G 000 115 A2.

Lock Cylinder

- Lubricate the lock cylinder.
- Use spray lubricant G 052 778 A2.

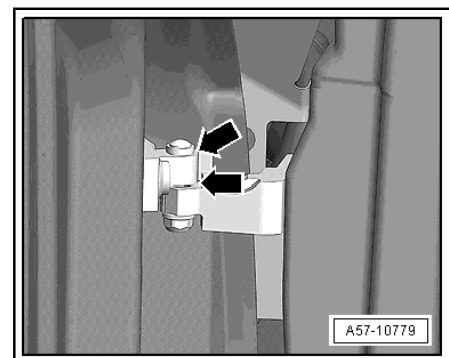

2.42 Transport Protection, Removing Front and Rear Suspension Strut Protectors

Two versions of protection devices are used. (front spring ridges , rear blocking pieces)

- Release coil spring (for example, put vehicle on lift)



Note

- ◆ *It is not necessary to remove the wheels.*
- ◆ *Be careful not to damage surface of coil springs.*
- Remove protection devices from springs.



Note

After removing the spring clip and the spacer and lubricating the strut tube cap, make sure that the boot in the strut bearing is in the correct position as with the shock absorber tube.

2.43 Underbody Protection, Inspecting for Damage

- When inspecting, observe underbody, wheel housings and sills!



WARNING

Eliminate any malfunctions (repair procedure).

2.44 Plenum Chamber Water Drain, Checking and Cleaning

- Remove the plenum chamber cover .



Note

- ◆ *Visually inspect plenum chamber for contaminants, for example, leaves.*
- ◆ *If there are contaminants, clean water drain and plenum chamber.*

Remove the plenum chamber cover. Refer to ⇒ Body Exterior; Rep. Gr. 50 ; Removal and Installation

2.45 Factory-Equipped Winter Tires



Note

- ◆ *On vehicles that were delivered from factory with winter tires, check for correct pressure during delivery inspection.*
- ◆ *The excessive speed warning label should be placed in driver field of vision.*

2.46 Clock, Setting

Radio Clock



Note

The clock can function as a radio-controlled quartz clock as well as a normal quartz clock.

If an acceptable radio clock signal is received, clock automatically switches to "radio-controlled quartz clock" operating mode. The radio clock reception symbol (radio tower radiating waves) appears in display. If the clock does not receive a valid signal, it automatically switches to "quartz clock" mode after 3 days and radio clock reception symbol goes out.

2.47 Spark Plugs, Removing and Installing

⇒ ["2.47.1 General Information", page 57](#)

⇒ ["2.47.2 6-Cylinder 3.2 MPI", page 59](#)

⇒ ["2.47.3 4-Cylinder, 2.0 TFSI", page 60](#)

⇒ ["2.47.4 4-Cylinder, 2.0 TFSI", page 60](#)

⇒ ["2.47.5 5-Cylinder, 2.5 TFSI", page 61](#)

2.47.1 General Information



Note

Observe waste disposal regulations!

Special tools and workshop equipment required

- ◆ Spark plug wrench -3122B-

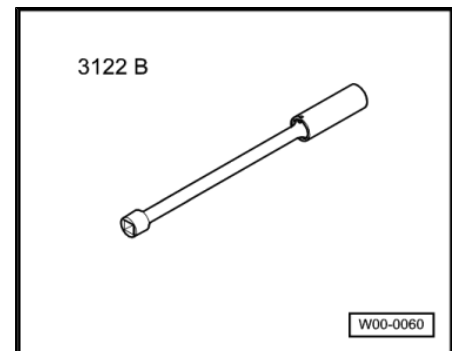

- ◆ Ignition Coil Puller -T40039-

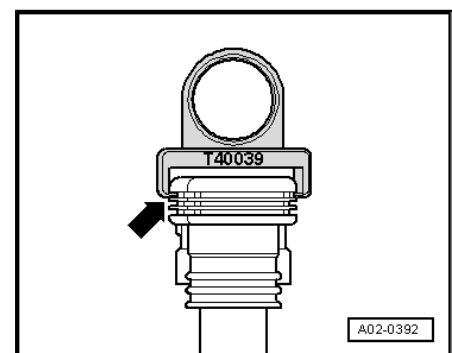

- ◆ Puller -T10095/a-

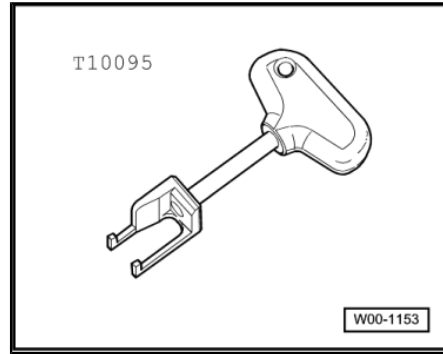

- ◆ Removal/installation tool -T10029-

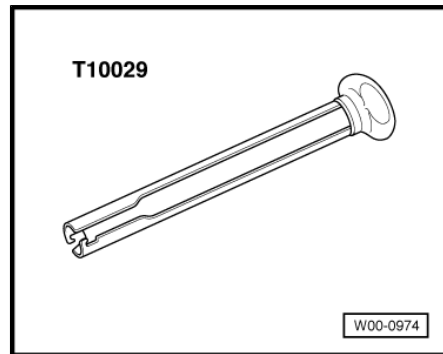

- ◆ Removal/installation tool -T10118-

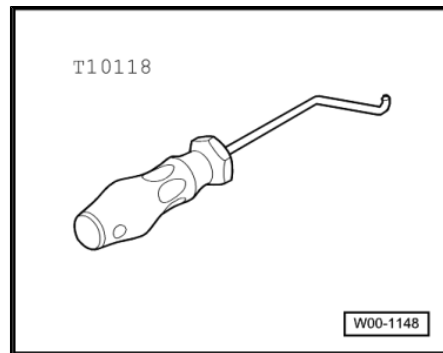

- ◆ Puller -T10094 A-

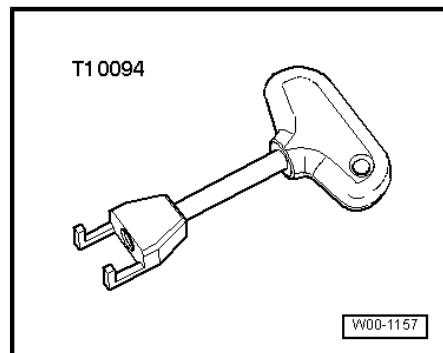

2.47.2 6-Cylinder 3.2 MPI

- Turn the ignition off.
- Remove connectors for ignition coils with power output stages -arrows-.

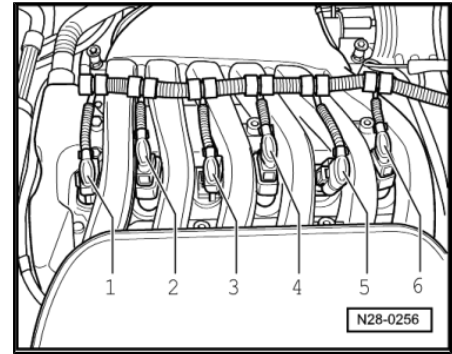

- Unlock the connector locating device with the assembly tool -T10118- .
- Place the assembly device -T10118- on the connector locating device -arrow-, and carefully pull the connector off.

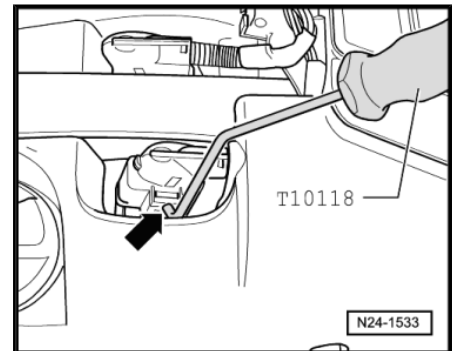

- Push the remover -T10095/a- from the straight connector side, in the direction of the arrow, on the ignition coil with power output stage
- Pull the ignition coil with power output stage up perpendicularly and out.

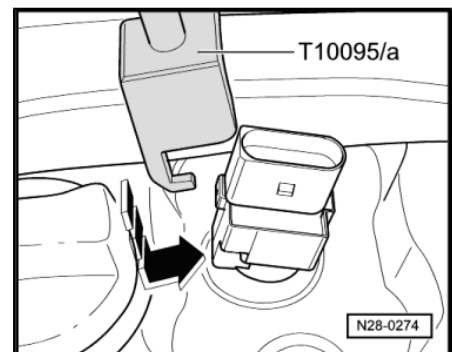

- Observe the installed locations of the ignition coils with power output stages to the connectors, before they are removed -arrows-.

The straight side of the connector must fit to the straight side of the ignition coil with power output stage.

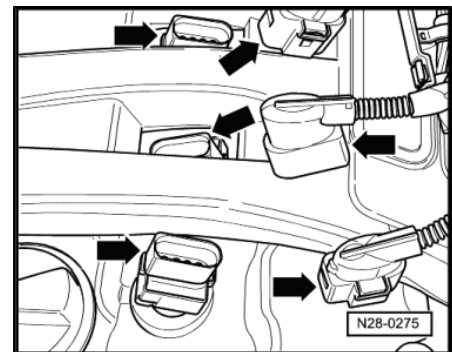

- Remove spark plugs using spark plug wrench -3122B- .
- Install new spark plugs with spark plug wrench -3122B- .

Tightening Specifications	Nm
Spark plugs in cylinder head	20

- Assembly is done in reverse order.

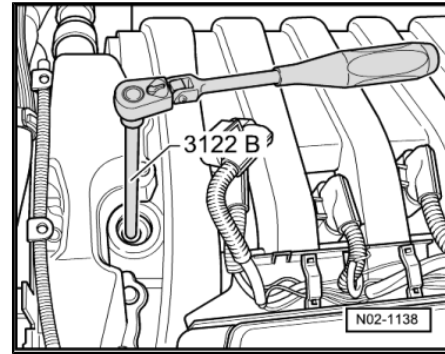

2.47.3 4-Cylinder, 2.0 TFSI

- Turn the ignition off.
- Disconnect the electrical connectors -arrows- and pull all the connectors evenly from the ignition coils.

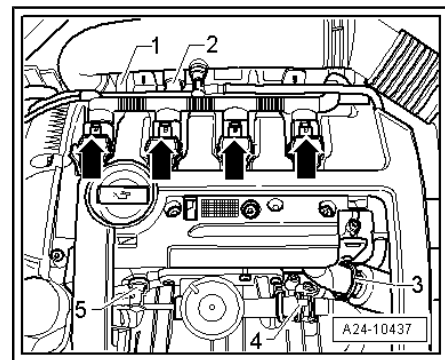

- Using the ignition coil puller -T40039- remove all the ignition coils from the spark plug shaft.
- Remove spark plugs with -3122 B- .
- Screw in new spark plugs using -3122 B- .
- Loosely place all ignition coils in spark plug shaft
- Align ignition coils to connectors and place all connectors evenly on ignition coils.
- Press ignition coils evenly by hand onto spark plugs (do not use a hammer).

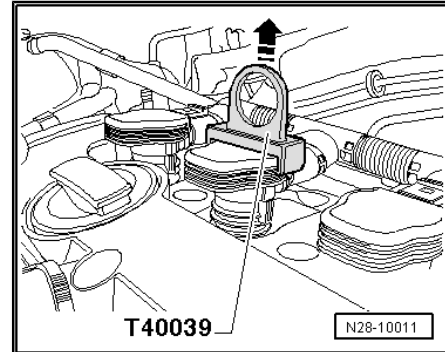

2.47.4 4-Cylinder, 2.0 TFSI

- Turn the ignition off.
- Remove the engine cover, refer to [⇒ "2.22 Engine Cover, Removing", page 37](#) .

- Remove both bolts -1-.
- Push connector -2- toward ignition coil, press on catch with hand and remove connector.
- Remove ignition coil from spark plug with Ignition Coil Puller - T40039- .
- Remove spark plugs with -3122 B- .
- Screw in new spark plugs using -3122 B- .

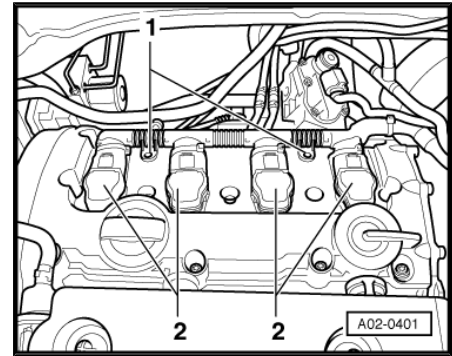

 **Note**

Push ignition coils by hand into intended resources in cylinder head cover.

- Install ignition coils by rotating slightly - they must engage noticeably.

Tightening Specifications	Nm
Spark plugs in cylinder head	30

2.47.5 5-Cylinder, 2.5 TFSI

- Turn the ignition off.
- Disconnect the connector -6- on the camshaft position sensor 3 -G300- .
- Remove both screws -arrows-.

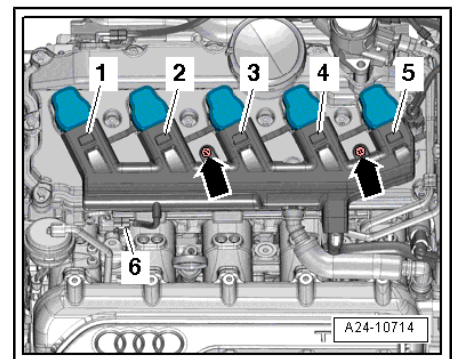

- Release the connectors and at the same time remove them from the ignition coils -1 through 5-.
- Slide the ignition coil puller -T40039- onto the ignition coil with power output stage and remove the ignition coil -arrow-.
- Remove spark plugs with -3122 B- .
- Screw in new spark plugs using -3122 B- .

Installing:

- Install all the ignition coils into the spark plug shaft.
- Align the ignition coils with the connectors and attach all the connectors at the same time onto the ignition coils.
- Press the ignition coils evenly onto the spark plugs by hand. Do not hit them.
- Tighten the ignition coil wire guide to the cylinder head cover.

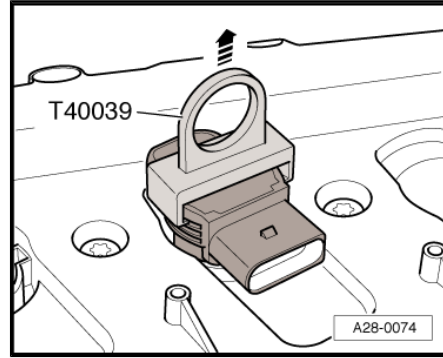

i Note

Push ignition coils by hand into intended resources in cylinder head cover.

- Install ignition coils by rotating slightly - they must engage noticeably.

Tightening Specifications	Nm
Spark plugs in cylinder head	30
Cable guide screws	5

Edition 10202011JY

Cautions & Warnings

Please read these WARNINGS and CAUTIONS before proceeding with maintenance and repair work. You must answer that you have read and you understand these WARNINGS and CAUTIONS before you will be allowed to view this information.

- If you lack the skills, tools and equipment, or a suitable workshop for any procedure described in this manual, we suggest you leave such repairs to an authorized Audi retailer or other qualified shop. We especially urge you to consult an authorized Audi retailer before beginning repairs on any vehicle that may still be covered wholly or in part by any of the extensive warranties issued by Audi.
- Disconnect the battery negative terminal (ground strap) whenever you work on the fuel system or the electrical system. Do not smoke or work near heaters or other fire hazards. Keep an approved fire extinguisher handy.
- Audi is constantly improving its vehicles and sometimes these changes, both in parts and specifications, are made applicable to earlier models. Therefore, part numbers listed in this manual are for reference only. Always check with your authorized Audi retailer parts department for the latest information.
- Any time the battery has been disconnected on an automatic transmission vehicle, it will be necessary to reestablish Transmission Control Module (TCM) basic settings using the VAG 1551 Scan Tool (ST).
- Never work under a lifted vehicle unless it is solidly supported on stands designed for the purpose. Do not support a vehicle on cinder blocks, hollow tiles or other props that may crumble under continuous load. Never work under a vehicle that is supported solely by a jack. Never work under the vehicle while the engine is running.
- For vehicles equipped with an anti-theft radio, be sure of the correct radio activation code before disconnecting the battery or removing the radio. If the wrong code is entered when the power is restored, the radio may lock up and become inoperable, even if the correct code is used in a later attempt.
- If you are going to work under a vehicle on the ground, make sure that the ground is level. Block the wheels to keep the vehicle from rolling. Disconnect the battery negative terminal (ground strap) to prevent others from starting the vehicle while you are under it.
- Do not attempt to work on your vehicle if you do not feel well. You increase the danger of injury to yourself and others if you are tired, upset or have taken medicine or any other substances that may impair you or keep you from being fully alert.
- Never run the engine unless the work area is well ventilated. Carbon monoxide (CO) kills.
- Always observe good workshop practices. Wear goggles when you operate machine tools or work with acid. Wear goggles, gloves and other protective clothing whenever the job requires working with harmful substances.
- Tie long hair behind your head. Do not wear a necktie, a scarf, loose clothing, or a necklace when you work near machine tools or running engines. If your hair, clothing, or jewelry were to get caught in the machinery, severe injury could result.

Cautions & Warnings

- Do not re-use any fasteners that are worn or deformed in normal use. Some fasteners are designed to be used only once and are unreliable and may fail if used a second time. This includes, but is not limited to, nuts, bolts, washers, circlips and cotter pins. Always follow the recommendations in this manual - replace these fasteners with new parts where indicated, and any other time it is deemed necessary by inspection.
- Illuminate the work area adequately but safely. Use a portable safety light for working inside or under the vehicle. Make sure the bulb is enclosed by a wire cage. The hot filament of an accidentally broken bulb can ignite spilled fuel or oil.
- Friction materials such as brake pads and clutch discs may contain asbestos fibers. Do not create dust by grinding, sanding, or by cleaning with compressed air. Avoid breathing asbestos fibers and asbestos dust. Breathing asbestos can cause serious diseases such as asbestosis or cancer, and may result in death.
- Finger rings should be removed so that they cannot cause electrical shorts, get caught in running machinery, or be crushed by heavy parts.
- Before starting a job, make certain that you have all the necessary tools and parts on hand. Read all the instructions thoroughly, do not attempt shortcuts. Use tools that are appropriate to the work and use only replacement parts meeting Audi specifications. Makeshift tools, parts and procedures will not make good repairs.
- Catch draining fuel, oil or brake fluid in suitable containers. Do not use empty food or beverage containers that might mislead someone into drinking from them. Store flammable fluids away from fire hazards. Wipe up spills at once, but do not store the oily rags, which can ignite and burn spontaneously.
- Use pneumatic and electric tools only to loosen threaded parts and fasteners. Never use these tools to tighten fasteners, especially on light alloy parts. Always use a torque wrench to tighten fasteners to the tightening torque listed.
- Keep sparks, lighted matches, and open flame away from the top of the battery. If escaping hydrogen gas is ignited, it will ignite gas trapped in the cells and cause the battery to explode.
- Be mindful of the environment and ecology. Before you drain the crankcase, find out the proper way to dispose of the oil. Do not pour oil onto the ground, down a drain, or into a stream, pond, or lake. Consult local ordinances that govern the disposal of wastes.
- The air-conditioning (A/C) system is filled with a chemical refrigerant that is hazardous. The A/C system should be serviced only by trained automotive service technicians using approved refrigerant recovery/recycling equipment, trained in related safety precautions, and familiar with regulations governing the discharging and disposal of automotive chemical refrigerants.
- Before doing any electrical welding on vehicles equipped with anti-lock brakes (ABS), disconnect the battery negative terminal (ground strap) and the ABS control module connector.
- Do not expose any part of the A/C system to high temperatures such as open flame. Excessive heat will increase system pressure and may cause the system to burst.

Cautions & Warnings

- When boost-charging the battery, first remove the fuses for the Engine Control Module (ECM), the Transmission Control Module (TCM), the ABS control module, and the trip computer. In cases where one or more of these components is not separately fused, disconnect the control module connector(s).
- Some of the vehicles covered by this manual are equipped with a supplemental restraint system (SRS), that automatically deploys an airbag in the event of a frontal impact. The airbag is operated by an explosive device. Handled improperly or without adequate safeguards, it can be accidentally activated and cause serious personal injury. To guard against personal injury or airbag system failure, only trained Audi Service technicians should test, disassemble or service the airbag system.
- Do not quick-charge the battery (for boost starting) for longer than one minute, and do not exceed 16.5 volts at the battery with the boosting cables attached. Wait at least one minute before boosting the battery a second time.
- Never use a test light to conduct electrical tests of the airbag system. The system must only be tested by trained Audi Service technicians using the VAG 1551 Scan Tool (ST) or an approved equivalent. The airbag unit must never be electrically tested while it is not installed in the vehicle.
- Some aerosol tire inflators are highly flammable. Be extremely cautious when repairing a tire that may have been inflated using an aerosol tire inflator. Keep sparks, open flame or other sources of ignition away from the tire repair area. Inflate and deflate the tire at least four times before breaking the bead from the rim. Completely remove the tire from the rim before attempting any repair.
- When driving or riding in an airbag-equipped vehicle, never hold test equipment in your hands or lap while the vehicle is in motion. Objects between you and the airbag can increase the risk of injury in an accident.

I have read and I understand these Cautions and Warnings.