

11 Engine

Specifications	Page
11 00 009 BMW Program Test – engine	11-0/3
050 Removal and fitting of engine	00/1
11 12 000 Removal and fitting of rocker cover	00/2
100 Removal and fitting of cylinder head	12/1
101 Replacement of cylinder head gasket	12/1
161 Replacement of cylinder head	12/5
561 Replacement of one valve guide	12/5
607 Re-working of valve seats and valves	12/6
621 Replacement of one valve seat ring	12/7
719 Planing of cylinder head sealing surface	12/7
11 13 000 Removal and fitting of oil sump	12/8
11 14 100 Removal and fitting of upper timing case cover	13/1
120 Removal and fitting of upper and lower timing case covers	14/1
571 Replacement of radial sealing ring in timing case cover	14/1
611 Replacement of radial sealing ring in clutch end cover	14/3
11 21 000 Removal and fitting of crankshaft	14/3
501 Replacement of crankshaft	21/1
571 Replacement of ball bearing in crankshaft	21/2
11 22 000 Removal and fitting of flywheel	21/4
051 Replacement of driving disc for torque converter	22/1
541 Replacement of starter gear ring	22/2
11 24 501 Replacement of one connecting rod	22/2
601 Replacement of one small end bushing	24/1
11 25 500 Removal and fitting of one piston	24/1
11 31 000 Removal and fitting of camshaft	24/1
051 Renewing timing chain	25/1
061 Renewing sprockets	31/1
090 Removing and installing chain tensioner piston	31/3
581 Replacement of chain tensioner rail	31/4
591 Replacement of sliding rail for timing chain	31/5
11 33 020 Removal and fitting of rocker shafts	31/6
11 34 004 Adjustment of valve clearances	31/6
509 Checking all valves for gastightness	33/1
550 Removal and fitting of valves	34/1
11 41 000 Removal and fitting of oil pump	34/1
151 Replacement of roller chain for oil pump drive	41/1
512 Disassembly and assembly of oil pump	41/2
11 42 020 Full-flow oil filter	41/3
11 51 000 Removal and fitting of water pump	42/1
502 Disassembly and assembly of water pump	51/1
11 52 000 Removal and fitting of cooling fan	51/1
11 53 000 Removal and fitting of coolant thermostat	52/1
050 Removal and fitting of branch flange	53/1
081 Replacement of remote thermometer sensor	53/1
321 Replacement of all coolant hoses	53/2
11 61 000 Replacement of intake manifold gaskets	53/2
050 Removal and fitting of intake air collector with throttle butterfly stub pipes	61/1
	61/2

051	Replacement of intake air collector	61/4
091	Replacement of auxiliary air hose	61/4
100	Replacement of front intake pipe gaskets	61/5
120	Replacement of rear intake pipe gaskets	61/5
180	Replacement of cover gasket on intake manifold	61/7
290	Removal and fitting of intake pipe	61/8
291	Replacement of intake pipe	61/9
370	Removal and fitting of one intake ram air pipe	61/9
420	Removal and fitting of all intake pipes	61/9
1 62 000	Replacement of exhaust manifold gaskets	62/1
051	Replacement of warm air guide jacket	62/1
1 81 001	Replacement of right-hand engine mounting	81/1
011	Replacement of left-hand engine mounting	81/1

Specifications

Engine	1502	1602	1802	2002	2002 A	2002 Ti	2002 tii
Model					89 (3.150)		
Bore	84 (3.307)						
Stroke	71 (2.795)				80 (3.150)		
Stroke/bore ratio	0.8		0.796		0.89		
Capacity (fiscal)	1563 (95.38)		1754 (107.04)		1977 (120.66)		
Capacity (effective)	1573 (95.99)		1766 (107.77)		1990 (121.44)		
Compression ratio	8.0:1		8.6:1		8.3:1	9.5:1	9.5:1 ¹⁾²⁾
Max. output	55.4 (75)	62.52 (85)	66.2 (90)		73.55 (100)	88.26 (120)	95.62 (130)
at engine speed	5800	5700	5250		5500	5500	5800
Cutout operates at					6600 ± 150		
Max. continuous engine speed					6000		
Max. permissible engine speed					6400		
Max. torque	120 (12.0) (87)	132 (13.2) (95)	146 (14.6) (106)		160 (16.0) (116)	170 (17.0) (123)	181 (18.1) (131)
at engine speed	3700	3500	3000		3500	3600	4500
Mean piston speed	13.7 (2697)	13.5 (2657)	12.4 (2441)		14.7 (2894)		15.4 (3031)
at engine speed	5800	5700	5250		5500		5800
Compression test		good normal poor			above 10.5 (149.3) 9.5 . . . 10.5 (135.1 . . . 149.3) below 9.0 (128)		
Test procedure			Use calibrated compression tester, with battery fully charged, engine at normal operating temperature and throttle butterfly fully open. Turn engine over at starting speed.				
Fuel consumption (DIN 70030 standard test method)	10.2 (27.7/ 23.1)	9.9 (28.5/ 23.8)	11.0 (25.7/ 21.4)		10.0 (28.2/ 23.5)		9.9 (28.5/ 23.8)

1) Compression ratio 9.5:1 and modified combustion chamber for BMW 2002 tii from Chassis No. 2 710 840, BMW 2002 tii RHD from Chassis No. 2 750 846 and BMW touring 2002 tii from Chassis No. 3 423 221. This can be seen by the code number "E12" cast into the cylinder head on the intake side. Prior to the chassis numbers stated above, the compression ratio was 10 : 1.

2) BMW 2002 tii USA version: 9.0:1

3) see also page 11-0/17

Specifications

Engine	1502	1602	1802	2002	2002 A	2002 T1	2002 T11
Model							
Engine lubrication: Lubrication system	Pressure feed circulation with full-flow filter, rotor oil pump or gear oil pump with chain drive from crankshaft, sheet steel sump						
Oil filter Pressure relief valve opening pressure	bar (lb/in ²)	2.2 ± 0.3 (31.3 ± 4.3)					
Oil pump	Rotor oil pump (Eaton system); previously gear type pump						
Oil pressure telltale illuminated below	bar (lb/in ²)	0.2 . . . 0.5 (2.8 . . . 7.1)					
Oil capacity	liters (imp pints/US quarts)	4 (7.0/4.2) +0.25 (0.44/0.5) for filter when replacing					
Max. oil consumption ²⁾	l/100 km (miles/imp pint) (miles/US quart)	0.2 175 295					
Oil grade	Brand-name HD oil for 4-stroke spark-ignition engines						
Viscosity at temperatures mainly above 30°C (86°F)	SAE 40 single-grade oil or SAE 20 W 50 multigrade oil						
the whole year above -10°C (18°F)	SAE 30 single-grade oil or SAE 20 W 40, SAE 20 W 50 multigrade oil						
mainly above 10°C (50°F)	SAE 20 single-grade oil or SAE 10 W 30, SAE 10 W 40, SAE 10 W 50 multigrade oil						
Oil pump: Oil pressure at engine idling speed at 4000 rev/min	bar (lb/in ²)	1.8...1.2 (11.4...17.1) 0.5...1.5 (7.1...21.4) ¹⁾ approx. 4.0 (approx. 56.9)					
Relief valve opening pressure	bar (lb/in ²)	4.12...4.5 (58.5...63.9) 4...5 (56.9...71.1) ¹⁾					
Free length of pressure relief spring	mm (in)	68 (2.68)					
Play outer rotor/pump housing	mm (in)	0.1 + 0.05 (0.0039 + 0.0020)					
Rotor outer diameter	mm (in)	57.1 - 0.025 (2.248 - 0.001)					
Housing inner diameter	mm (in)	57.2 + 0.025 (2.252 + 0.001)					
Rotor height	mm (in)	-0.015 (-0.00059) 16 (0.6299) -0.045 (-0.00177)					
Housing depth	mm (in)	+0.050 (+0.0019) 16 (0.6299) +0.020 (+0.0008)					

1) Gear type oil pump
2) see also Page 11-0/17

Specifications

Engine	1502	1602	1802	2002	2002 A	2002 Ti	2002 tii
Oil pump (continued)							
Axial play rotor (inner/outer) /housing	mm (in)			0.035...0.095 (0.001374)			
Gap inner/outer rotor	mm (in)			0.12...0.20 (0.0047...0.0079)			
Max. depth of cover wear	mm (in)			0.05 (0.0020)			
Distance between housing partition and gear wheel bearing surface at hub	mm (in)			42.7±0.1 (1.681±0.0039)	34.5±0.1 (1.358±0.0039) ¹⁾		
Drive to rotor type oil pump				3/8 x 5/32 single roller chain			
Number of links				46 ²⁾			
Number of chain sprocket teeth	(1)			18			
	(2)			27			
Valve clearances:							
Adjustment with engine at operating temperature	mm (in)			0.20 ... 0.25 (0.0079 ... 0.0098) ³⁾			
Valve clearance adjustment				by eccentrics at rockers			
Sequence of adjustment							Valve overlap on Cylinder No.
		TDC on Cylinder No.					4
		1					2
		3					1
		4					3
		2					
Valve timing:							
Inlet opens				with 0.5 mm (0.02 in) clearance between cam base circle and rocker pad			
Inlet closes				4°BTDC			
Exhaust opens	°CS			52°ABDC			
Exhaust closes				52°BBDC			
Total period				4°ATDC			
				236°			
Inlet opens				with 0.28 mm (0.011 in) clearance between cam base circle and rocker pad			
Inlet closes				18°BTDC			
Exhaust opens	°CS			66°ABDC			
Exhaust closes				66°BBDC			
Total period				18°ATDC			
				264°			

1) Gear type oil pump

2) Gear type pump: 44 links

3) With max. coolant temperature 35°C (95°F): 0.15...0.20 mm (0.0059...0.0079 in)

Specifications

Engine	1502	1602	1802	2002	2002 A	2002 Ti	2002 tii
Model							
Valve gear:	by light alloy rockers with case-hardened pads and overhead camshaft						
Valve operation	duplex roller chain with automatic oil-damped chain tensioner with recoil safety device						
Camshaft drive	3/8"x7/32						
Timing chain	6.35 (0.25)						
Roller diameter	94						
Number of links	103.8±0.2 (4.0867±0.0079)						
Valves:	104.3±0.2 (4.1063±0.0079)						
Overall length							
Inlet	42	0 (1.6536)	0	0	44	0 (1.7323) ¹⁾	
Exhaust		-0.16	-0.006		-0.16	-0.006	
Valve head dia. Inlet	35	0 (1.378)	0	0	38	0 (1.496)	
Exhaust		-0.16	-0.006		-0.16	-0.006	
Valve stem dia. Inlet	8	-0.025 (315	-0.00098)				
Exhaust		-0.040	-0.00157				
Min edge thickness of valve head	8	-0.040 (0.315	-0.00157)				
Inlet		-0.055	-0.00217				
Exhaust	1.5	±0.10 (0.059	±0.00394)				
Min edge thickness of valve head	2.0	±0.15 (0.078	±0.00591)				
Matching limit	1.0	±0.1 (0.0393	±0.00394)				
Inlet	1.5	±0.15 (0.059	±0.00591)				
Exhaust	45°	30' + 30'					
Valve seat angle	45°	30' + 30'					
Inlet	0.02	(0.00079)					
Exhaust	0.02	(0.00079)					
Max. permissible runout of valve seat/stem	1) If "E12" cast into cylinder head: 46-0.16 mm (1.81 1-0.006 in)						
Inlet							
Exhaust							

1) If "E12" cast into cylinder head: 46-0.16 mm (1.81 1-0.006 in)

Specifications

Engine	1502	1602	1802	2002	2002 A	2002 Ti	2002 tii
Model							
Valve seat rings:							
Extl. dia.							
Inlet		44.15 ^{-0.009} (1.738 ^{-0.00035}) -0.025 ^{-0.00098}			47.15 ^{-0.009} (1.856 ^{-0.00035}) -0.025 ^{-0.00098}		
Exhaust		38.15 ^{-0.009} (1.502 ^{-0.00035}) -0.025 ^{-0.00098}			40.15 ^{-0.009} (1.581 ^{-0.00035}) -0.025 ^{-0.00098}		
Oversizes¹⁾							
Inlet		44.35 ^{-0.009} (1.746 ^{-0.00035}) -0.025 ^{-0.00098}			47.35 ^{-0.009} (1.864 ^{-0.00035}) -0.025 ^{-0.00098}		
Exhaust		44.55 ^{-0.009} (1.754 ^{-0.00035}) -0.025 ^{-0.00098}			47.55 ^{-0.009} (1.872 ^{-0.00035}) -0.025 ^{-0.00098}		
		38.35 ^{-0.009} (1.510 ^{-0.00035}) -0.025 ^{-0.00098}			40.35 ^{-0.009} (1.589 ^{-0.00035}) -0.025 ^{-0.00098}		
		38.55 ^{-0.009} (1.518 ^{-0.00035}) -0.025 ^{-0.00098}			40.55 ^{-0.009} (1.597 ^{-0.00035}) -0.025 ^{-0.00098}		
Dia. of cylinder head bore for valve seat ring¹⁾							
Inlet		44 ^{+0.025} 0			47 ^{+0.025} 0		
Exhaust		38 ^{+0.025} 0			40 ^{+0.025} 0		
Shrink fit²⁾ in cylinder head							
Valve seat angle			0.10...0.15 (0.00394...0.00591)				
Extl. correction angle			45°				
			15°				
Valve seat width:							
Inlet		1.55...2.05 (0.0610...0.0807)			1.50...2.10 (0.0591...0.0827)		
Exhaust		1.50...2.10 (0.0591...0.0827)			1.55...2.05 (0.0610...0.0807)		

1) For diameter of oversize bore in cylinder head, note shrink fit measurement.

2) Cylinder head heated to approx. 200°C (392°F), valve seat ring chilled to approx. -70°C (-94°F).

Specifications

Engine	1502	1602	1802	2002	2002 A	2002 TI	2002 til
Model							
Valve guides:							
Overall length	mm (in)	52 (2.047)					
Extl. dia.	mm (in)	14 ^{+0.033} _{+0.051} (0.5512 ^{+0.00130})					
Over-size diameters	mm (in)	14.1/14.2/14.3(0.5551/0.5590/0.5630)					
Intl. dia.	mm (in)	8 ^{+0.015} ₀ (0.3150 ^{+0.00059})					
Dia. of bore in cylinder head	mm (in)	14 ^{-0.018} ₀ (0.5512 ^{-0.00071})					
Over-size diameters	mm (in)	14.1/14.2/14.3(0.5551/0.5590/0.5630)					
Projection in cylinder head	mm (in)	15±0.5(0.591±0.02)					
Shrink fit in cylinder head	mm (in)	0.015...0.044(0.0006...0.0017)					
Temperature to which cylinder head must be heated	°C(°F)	220...250 (428...482)					
Valve running clearances:							
Inlet	mm (in)	0.025...0.055(0.00098...0.00216)					
Exhaust	mm (in)	0.040...0.070(0.00157...0.00275)					
Max. wear tolerance	mm (in)	0.15 (0.0059)					
Valve springs:							
Identification		green paint spot					
Wire thickness	mm (in)	4.25 (0.167)					
Outer coil diameter	mm (in)	31.9±0.2 (1.256±0.0079)					
Free length of spring	mm (in)	43.5(1.7126) or 46.0(1.8110) ¹⁾					
Spring force and test length		29±1.6kp/37.6mm(63.9±3.5 lb/1.480in)			70±2.8kp/28.5mm(154±6.171b/1.122in)		
Rockers:							
Bore for rocker shaft	mm (in)	15.5±0.018(0.6103±0.00071)					
Bore dia in cylinder head	mm (in)	15.5±0.043(0.6102±0.00169)					
Rocker shaft dia.	mm (in)	15.5 ^{-0.016} _{-0.034} (0.6103 ^{-0.00063})					

1) depending on make (but spring force remains 29±1.6kp (63.9±3.5lb) at installed length of 37.6 mm (1.480 in)

Specifications

Engine	1502	1602	1802	2002	2002 A	2002 Ti	2002 tii
Model							
Rocker shaft running clearance	mm (in)			0.016...0.077(0.00063...0.0030)			
Rocker running clearance	mm (in)			0.016...0.052(0.00063...0.00205)			
Camshaft							
Camshaft diameters	mm (in)	35/42/43 -0.041	-0.025 (1.3780/1.6536/1.6929 -0.00098) -0.00161				
Bore in cylinder head	mm (in)	35/42/43 +0.034 +0.009	(1.3780/1.6536/1.6929 +0.00134) +0.00035				
Running clearance	mm (in)		0.034...0.075(0.00134...0.00295)				
Axial play	mm (in)		0.02...0.13(0.00079...0.00512)				
Max. permissible vertical runout of worm wheel (distributor drive)	mm (in)		0.1(0.004)				
Cam base circle dia.	mm (in)		26.7612(1.0536)				
Cam lift	mm (in)		7.0267±0.080 (0.2766±0.0031)				
Chain tensioner:							
Piston length	mm (in)		62(2.441)				
Compression spring for tensioning rail, free length	mm (in)		155.5(6.122)				
Wire thickness	mm (in)		1±0.015(0.0394±0.00059)				
Crankshaft:							
Dia. of bearing bore in crankcase red	mm (in)		60 0	+0.010 (2.3622 0) +0.00039			
blue	mm (in)		60	+0.010 (2.3622 0) +0.00039			
				+0.019 0.00075			
Grinding stages		Original	Stage 1	Stage 2	Stage 3		
Bearing shell thickness	mm	2.50 -0.010	2.625 -0.010	2.750 -0.010	2.875 -0.010		
red	mm	2.50 -0.025	2.625 -0.020	2.750 -0.020	2.875 -0.020		
	in	0.09843 -0.00039	0.10335 -0.00039	0.10827 -0.00039	0.11319 -0.00039		
		-0.00079	-0.00079	-0.00079	-0.00079		
blue	mm	2.51 -0.010	2.635 -0.010	2.760 -0.010	2.885 -0.010		
	mm	2.51 -0.020	2.635 -0.020	2.760 -0.020	2.885 -0.020		
		0.09882 -0.00039	0.10374 -0.00039	0.10866 -0.00039	0.11358 -0.00039		
		-0.00079	-0.00079	-0.00079	-0.00079		

Model	1502	1602	1802	2002	2002 A	2002 Ti	2002 tti
Crankshaft:							
Regrinding stages	Original		Stage 1		Stage 2		Stage 3
Main bearing journal dia. red	mm	55 -0.010 -0.020 -0.00039 -0.00079	54.75 -0.010 -0.020 -0.00039	54.50 -0.010 -0.020 -0.00039	54.25 -0.010 -0.020 -0.00039	54.25 -0.010 -0.020 -0.00039	54.25 -0.010 -0.020 -0.00039
	in	2.1654 -0.00079 -0.00079	2.1555 -0.00079 -0.00079	2.1457 -0.00079 -0.00079	2.1358 -0.00079 -0.00079	2.1358 -0.00079 -0.00079	2.1358 -0.00079 -0.00079
	mm	55 -0.020 -0.029 -0.00079 -0.00114	54.75 -0.020 -0.029 -0.00079 -0.00114	54.50 -0.020 -0.029 -0.00079 -0.00114	54.25 -0.020 -0.029 -0.00079 -0.00114	54.25 -0.020 -0.029 -0.00079 -0.00114	54.25 -0.020 -0.029 -0.00079 -0.00114
	in	2.1654 -0.00079 -0.00079	2.1555 -0.00079 -0.00079	2.1457 -0.00079 -0.00079	2.1358 -0.00079 -0.00079	2.1358 -0.00079 -0.00079	2.1358 -0.00079 -0.00079
Bearing play, radial	mm (in)	0.030...0.070(0.00118...0.002756)	0.030...0.068(0.00118...0.002677)	0.030...0.068(0.00118...0.002677)	0.030...0.068(0.00118...0.002677)	0.030...0.068(0.00118...0.002677)	0.030...0.068(0.00118...0.002677)
	mm (in)	0.030...0.068(0.00118...0.002677)	0.030...0.068(0.00118...0.002677)	0.030...0.068(0.00118...0.002677)	0.030...0.068(0.00118...0.002677)	0.030...0.068(0.00118...0.002677)	0.030...0.068(0.00118...0.002677)
	mm	48 -0.009 -0.025 -0.00035	47.75 -0.009 -0.025 -0.00035	47.50 -0.009 -0.025 -0.00035	47.25 -0.009 -0.025 -0.00035	47.25 -0.009 -0.025 -0.00035	47.25 -0.009 -0.025 -0.00035
	in	1.8898 -0.00098 -0.00098	1.8799 -0.00098 -0.00098	1.8701 -0.00098 -0.00098	1.8602 -0.00098 -0.00098	1.8602 -0.00098 -0.00098	1.8602 -0.00098 -0.00098
Max. permitted imbalance (dynamic without flywheel)	50 cmp						
Guide bearing width	mm	30 -0.060 -0.110 -0.00236 -0.00433	30.2 -0.060 -0.110 -0.00236 -0.00433	30.4 -0.060 -0.110 -0.00236 -0.00433	30.6 -0.060 -0.110 -0.00236 -0.00433	30.6 -0.060 -0.110 -0.00236 -0.00433	30.6 -0.060 -0.110 -0.00236 -0.00433
	in	1.1811 -0.00433 -0.00433	1.1890 -0.00236 -0.00433	1.1969 -0.00236 -0.00433	1.2047 -0.00236 -0.00433	1.2047 -0.00236 -0.00433	1.2047 -0.00236 -0.00433
Crankshaft end float	mm (in)	0.085...0.174(0.00335...0.00685)	0.085...0.174(0.00335...0.00685)	0.085...0.174(0.00335...0.00685)	0.085...0.174(0.00335...0.00685)	0.085...0.174(0.00335...0.00685)	0.085...0.174(0.00335...0.00685)
Max. permissible runout of centre main bearing journal (crankshaft supported at outer main bearing journals)	mm (in)	0.1 (0.00393) ¹⁾	0.1 (0.00393) ¹⁾	0.1 (0.00393) ¹⁾	0.1 (0.00393) ¹⁾	0.1 (0.00393) ¹⁾	0.1 (0.00393) ¹⁾
Crankshaft throw	mm (in)	71±0.1 (2.795±0.00394)	71±0.1 (2.795±0.00394)	71±0.1 (2.795±0.00394)	71±0.1 (2.795±0.00394)	71±0.1 (2.795±0.00394)	71±0.1 (2.795±0.00394)
Max. permissible roughness of bearing journal surfaces	Rt (microns)	1.5	1.5	1.5	1.5	1.5	1.5
Max. perm. radial runout of 25 mm and 22 mm dia. journals relative to main bearing journal	mm (in)	0.05(0.00197)	0.05(0.00197)	0.05(0.00197)	0.05(0.00197)	0.05(0.00197)	0.05(0.00197)
Connecting rods:							
Overall length	mm (in)	135±0.1(5.315±0.00394)	135±0.1(5.315±0.00394)	135±0.1(5.315±0.00394)	135±0.1(5.315±0.00394)	135±0.1(5.315±0.00394)	135±0.1(5.315±0.00394)
Small end bearing bore in connect. rod	mm (in)	24±0.021(0.945±0.00083)	24±0.021(0.945±0.00083)	24±0.021(0.945±0.00083)	24±0.021(0.945±0.00083)	24±0.021(0.945±0.00083)	24±0.021(0.945±0.00083)
Outer dia. of small end bush	mm (in)	24.06...24.10(0.9472...0.9488)	24.06...24.10(0.9472...0.9488)	24.06...24.10(0.9472...0.9488)	24.06...24.10(0.9472...0.9488)	24.06...24.10(0.9472...0.9488)	24.06...24.10(0.9472...0.9488)
Inner dia. of small end bush	mm (in)	22±0.010 (+0.00039) +0.005	22±0.010 (+0.00039) +0.005	22±0.010 (+0.00039) +0.005	22±0.010 (+0.00039) +0.005	22±0.010 (+0.00039) +0.005	22±0.010 (+0.00039) +0.005
Dia. of big end bore	mm (in)	52±0.015 (2.0472±0.0006)	52±0.015 (2.0472±0.0006)	52±0.015 (2.0472±0.0006)	52±0.015 (2.0472±0.0006)	52±0.015 (2.0472±0.0006)	52±0.015 (2.0472±0.0006)

1) Previously 0.02 mm (0.00078 in) with the 6-hole crankshaft

Specifications

Engine	1502	1602	1802	2002	2002 A	2002 TI	2002 tii
Model			Stage 1		Stage 2	Stage 3	
Bearing shell thickness			2.108 ... 2.118		2.233 ... 2.243	2.358 ... 2.368	
Regrind stages	Original 1.983 ... 1.993 (0.0781 ... 0.0785)		(0.0830 ... 0.0834)		(0.0879 ... 0.0883)	(0.0928 ... 0.0932)	
Radial bearing play			0.023 ... 0.069 (0.0009 ... 0.0027)				
Max. out-of-parallel of connecting rod holes with bearing sleeves 150 mm (5.9055 in) apart			0.04 (0.0015)				
Max. permissible distortion to one side			0° 30'				
Max. deviation of connecting rod weights in one engine			4 (0.140)				
Cylinders							
Original bore							
Grinding categories							
A mm (in)	84.000 ^{+0.009} (3.307 ^{+0.003543})				89.000 ^{+0.009} (3.5039 ^{+0.003543})		
B mm (in)	84.010 ^{+0.009} (3.3074 ^{+0.003543})				89.010 ^{+0.009} (3.5042 ^{+0.003543})		
C mm (in)	84.020 ^{+0.009} (3.3078 ^{+0.003543})				89.020 ^{+0.009} (3.5046 ^{+0.003543})		
First rebore categories							
A mm (in)	84.250 ^{+0.009} (3.3168 ^{+0.003543})				89.250 ^{+0.009} (3.5137 ^{+0.003543})		
B mm (in)	84.260 ^{+0.009} (3.3173 ^{+0.003543})				89.260 ^{+0.009} (3.5141 ^{+0.003543})		
C mm (in)	84.270 ^{+0.009} (3.3177 ^{+0.003543})				89.270 ^{+0.009} (3.5145 ^{+0.003543})		
Second rebore categories							
A mm (in)	84.500 ^{+0.009} (3.3267 ^{+0.003543})				89.500 ^{+0.009} (3.5235 ^{+0.003543})		
B mm (in)	84.510 ^{+0.009} (3.3271 ^{+0.003543})				89.510 ^{+0.009} (3.5239 ^{+0.003543})		
C mm (in)	84.520 ^{+0.009} (3.3275 ^{+0.003543})				89.520 ^{+0.009} (3.5243 ^{+0.003543})		
Cylinders¹⁾							
Bore — original							
mm (in)	84.015 ^{±0.005} (3.3077 ^{±0.0002})				89.015 ^{±0.005} (3.5045 ^{±0.0002})		
Bore — intermediate							
mm (in)	84.095 ^{±0.005} (3.3108 ^{±0.0002})				89.095 ^{±0.005} (3.5077 ^{±0.0002})		
1st rebore							
mm (in)	84.265 ^{±0.005} (3.3175 ^{±0.0002})				89.265 ^{±0.005} (3.5144 ^{±0.0002})		
2nd rebore							
mm (in)	84.515 ^{±0.005} (3.3274 ^{±0.0002})				89.515 ^{±0.005} (3.5242 ^{±0.0002})		

¹⁾ from introduction of standard piston

Specifications

Engine	1502	1602	1802	2002	2002 A	2002 T1	2002 t11	
Model			3...4					
Surface roughness	μ							
Max. perm. out-of-roundness of cyl. bore	0.01 (0.00039)							
Max. permissible taper of cyl. bore	0.01 (0.00039)							
Max. permissible deviation of cylinder centre from bearing bore vertical	5'							
Max. permissible total wear play on piston and cyl.	0.10...0.15 (0.00394...0.00591)							
Pistons:	stamped + or -							
Weight groups	stamped W or S							
Piston pin category								
Original piston dia.	A mm (in)	83.96 (3.2954)				88.96 (3.5023)		
	B mm (in)	83.97 (3.2958)				88.97 (3.5027)		
	C mm (in)	83.98 (3.2962)				88.98 (3.5031)		
Intermediate size	A mm (in)	84.04 (3.3086)				89.04 (3.5054)		
	B mm (in)	84.05 (3.3090)				89.05 (3.5058)		
	C mm (in)	84.06 (3.3094)				89.06 (3.5062)		
1st oversize +0.25 mm (0.0098 in)	A mm (in)	84.21 (3.3153)				89.21 (3.5121)		
	B mm (in)	84.22 (3.3157)				89.22 (3.5125)		
	C mm (in)	84.23 (3.3161)				89.23 (3.5129)		
2nd oversize +0.50 mm (0.0197 in)	A mm (in)	84.46 (3.3252)				89.46 (3.5220)		
	B mm (in)	84.47 (3.3256)				89.47 (3.5224)		
	C mm (in)	84.48 (3.3259)				89.48 (3.5227)		
Pistons ¹⁾	stamped + or -							
Weight group								
Original piston dia.	mm (in)	83.97 (3.3059)				88.97 (3.5027)		
Intermediate size	mm (in)	84.05 (3.3090)				89.05 (3.5059)		
1st oversize +0.25 mm (0.0098 in)	mm (in)	84.22 (3.3157)				89.22 (3.5126)		
2nd oversize +0.50 mm (0.0197 in)	mm (in)	84.47 (3.3256)				89.47 (3.5224)		
Piston installed clearance	mm (in)						0.045 (0.0018)	
Max. permissible deviation in weight of complete pistons in one engine	g(oz)						9...10(0.315...0.350)	

1) from introduction of standard pistons

Specifications

Engine	1502	1602	1802	2002	2002 A	2002 TI	2002 tii
Model							
Piston rings:							
First groove (rectangular ring) Height			1.75 ⁻ 0.010 (0.0688 -0.022)	-0.00039 -0.00866			
Ring gap			0.30...0.50 (0.0118...0.0197)				
Side clearance			0.060...0.082 (0.0024...0.0032)				
Second groove (cut-back micro-angle ring) ¹⁾ Height			2 ⁻ 0.010 (0.0787 -0.022)	-0.00004 -0.00087			
Ring gap	0.30 ... 0.45 (0.0118 ... 0.0177)				0.2...0.4 ²⁾ (0.0079...0.0157)		
Side clearance			0.030...0.062 (0.0012...0.0024) ³⁾				
Third groove (oil scraper ring -- equal chamfer) ⁴⁾ Height			4 ⁻ 0.010 (0.1574 -0.022)	-0.000 -0.008			
Ring gap			0.25...0.40 (0.0098...0.0157)				
Side clearance			0.020...0.052 (0.0008...0.0020) ⁴⁾				
Piston pins:							
Piston pin displacement from piston centre			1.5 (0.059)				
Piston pin dia. (white mark)			22 ⁰ (0.8661 ⁰)	-0.0001			
(black mark)			22 ⁻ 0.003 (0.8661 ⁻ 0.0001)	-0.0002			
Bore dia. in piston pin eyes			22 ^{+0.004} (0.8661 ^{+0.00015})	0			
Piston pin play in piston ⁵⁾			0.002...0.006 (0.00008...0.0024)				
Piston pin running clearance in small end bush (white mark)			0.005...0.013 (0.00020...0.00051)				
(black mark)			0.008...0.016 (0.00031...0.00063)				
Thermostat:							
Opening begins			80 ± 1.5 (176 ± 2.7)				

- 1) Does not comply with DIN standard; special BMW version
- 2) Previous compression ring 0.30...0.45 mm (0.0118...0.0177 in)
- 3) 0.040...0.072 mm (0.0016...0.0028 in) on KS pistons
- 4) 0.030...0.062 mm (0.0012...0.0024 in) on KS pistons
- 5) Renew piston and piston pin as a complete unit

- 6) Compression ring (cut back) as from following chassis numbers: BMW 1802 3 542 700; BMW 1802 touring 3 552 208; BMW 2002 3 640 844; BMW 2002 A 2 512 500; BMW 2002 RHD 1 659 437; BMW 2002 USA 2 588 660; BMW 2002 A RHD 2 521 628; BMW 2002 A USA 2 533 876; BMW touring 2002 3 358 413; BMW touring 2002 RHD 3 441 210; BMW 2002 tii 2 716 181; BMW 2002 tii RHD 2 751 394; BMW 2002 USA 2 763 234; BMW touring 2002 tii 3 424 328.

Engine Model	1502	1602	1802	2002	2002 A	2002 TI	2002 tii
Water pump: Clearance between housing and impeller				1±0.2 (0.0394±0.0079)			
Flywheel: Max. imbalance, dynamic			5				
Max. axial runout measured at 200 mm (7.874 in) dia.			0.1 (0.0039)				
Max. permissible reworking of contact surface			0.4 + 0.1 (0.0157 + 0.0394)				
Min. thickness, measured at contact surface	13.5 (0.531)			14.5 (0.571) ¹⁾			

1) Does not apply to automatic transmission models

Tightening torques in Nm (mkp) (lb.ft)

Engine to gearbox M8 M10	25...27 (2.5...2.7)(18...19.5)
Cylinder head bolts, crosswise from center in 3 stages	47...51 (4.7...5.1) (34...37)
Stage 1	35...45 (3.5...4.5) (25...33)
Stage 2	60...65 (6.0...6.5) (43...47)
Stage 3	68...72 (6.8...7.2) (49...52) ¹⁾
Main bearing caps	58...63 (5.8...6.3) (42...46)
Big end bolts 12.9 DIN 267	52...57 (5.2...5.7) (38...41)
Flywheel to crankshaft ²⁾	100...115 (10.0...11.5) (72...83)
Chain tensioner end plug	30...40 (3.0...4.0) (22...29)
Rocker clamp bolt	9...11 (0.9...1.1) (6.5...8)
Pressure relief valve plug on oil pump housing	25...30 (2.5...3.0) (18...22)
Oil drain plug	60...65 (6.0...6.5) (43...47)
Full-flow oil filter (throwaway element) with engine cold	24...26 (2.4...2.6) (17...19)
Clutch to flywheel	22...24 (2.2...2.4) (16...17.4)
Oil sump to engine block and timing case cover	9...11 (0.9...1.1) (6.5...8)
Hollow screw for oil line to camshaft	11...13 (1.1...1.3) (8...9.4)
V-belt pulley on crankshaft	140...150 (14.0...15.0) (101...108)
Spark plugs	25...30 (2.5...3.0) (18...22)
Fuel pump	10...14 (1.0...1.4) (7.2...10)
Carburetor on intake manifold	10...14 (1.0...1.4) (7.2...10)
Upper to lower timing case cover	9...11 (0.9...1.1) (6.5...8)
Distributor flange at cylinder head M8 M6	23...27 (2.3...2.7) (16.6...19.5)
Hex nut for exhaust manifold to cylinderhead	9...11 (0.9...1.1) (6.5...8)
Heat-sensitive valve	30...33 (3.0...3.3) (22...24)
Eccentric at rocker	15 (1.5) (11)
Heat-sensitive time switch	9...11 (0.9...1.1) (6.5...8)
Coolant temperature sensor	20...25 (2.0...2.5) (14.4...18)
Oil pressure contact switch	20...25 (2.0...2.5) (14.4...18)
Reversing light switch	30...35 (3.0...3.5) (22...25)
	6...10 (0.6...1.0) (4.3...7.2)

1) With engine cold (max. 36°C, 96°F)

2) Fit in with Loctite Type 270 and Activator N

Specifications

Engine	2002	2002 A	2002 TI
Exhaust gas recombustion system for USA version Air pump	Messrs. Saginaw		
Max. continuous speed	rpm	5000	
Max. speed	rpm	7800	
Permitted exhaust air temperature	°C (°F)	120 (248)	
Max. permissible	°C (°F)	185 (365)	
Max. permissible intake vacuum with throttle valve fully opened	atm (psi)	0.086 (1.223)	
Max. continuous pressure	atm (psi)	0.83 (11.2)	
Pressure regulating cartridge		Messrs. Saginaw, Order No. 300-S-38	
Max. press-in force, pressure regulating cartridge	kp (lb)	18 (39.69)	
Belt pulley: Permitted imbalance, dynamic		5 cmp	
Control valve		GULP System	
Opening time	sec.	1.82 ÷ 2.55	
Non-return valve Type		DELCO	
Oil filter Type		Purolator	
Return stop Opening pressure	kp/cm ² (psi)	0.09 ÷ 0.12 (1.28 ÷ 1.71)	
By-pass valve Opening pressure	kp/cm ² (psi)	2.2 ± 0.3 (31.28 ± 4.3)	
Injection pipes		replaceable	
Installed length	mm (in)	37 - 1 (1.457 - 0.0394)	

Specifications

Engine

Model	1602	1802 1800 touring	2002 2000 touring	2002 TI	2002 tii
Standard values ¹⁾ for engine test on roller test stand					
Max. useful output in bhp (DIN)	85	90	100	120	130
at	5700	5250	5500		5800
rpm					
Test speed 3rd gear kph (mph)	110 (68.4)	104 (64.6)	120 (74.6)	125 (77.7)	140 (87)
Rating ²⁾	kg	kg	kg	kg	kg
	hp	hp	hp	hp	hp
	167	177	180	205	199
	70.3	74.3	82.7	97.7	106.6
	166	176	179	104	198
	69.9	73.9	82.2	97.2	106
	165	175	178	203	197
	69.5	73.5	81.6	96.8	105.5
	164	174	177	202	196
	69.0	73.1	81.1	96.3	105.0
	163	173	176	201	195
	68.6	72.7	80.6	95.8	104.5
	162	172	175	200	194
	68.2	72.2	80.2	95.4	104
	161	171	174	199	193
	67.8	71.8	79.8	94.9	103.5
	160	170	173	198	192
	67.4	71.4	79.4	94.5	103.0
	159	169	172	197	191
	67.0	71.0	78.9	94.0	102.4
	158	168	171	196	190
	66.6	70.6	78.5	93.5	101.9
	157	167	170	195	189
	66.2	70.4	78.0	93.0	101.4
	156	166	169	194	188
	65.7	69.9	77.5	92.6	100.9
	155	165	168	193	187
	65.3	69.5	77.0	92.1	100.4
	154	164	167	192	186
	64.9	69.0	76.5	91.6	99.9
	153	163	166	191	185
	64.6	68.6	76.1	91.1	99.4
	152	162	165	190	184
	64.2	68.1	75.7	90.7	98.9
	151	161	164	189	183
	63.8	67.7	75.3	90.3	98.4
	150	160	163	188	182
	63.4	67.3	74.9	89.8	97.8
Sufficient	kg	kg	kg	kg	kg
	149	159	162	187	181
	63.0	66.9	74.5	89.4	97.3
	148	158	161	186	180
	62.6	66.5	74.0	88.9	96.7
	147	157	160	185	179
	62.2	66.1	73.5	88.4	96.2
	146	156	159	184	178
	61.8	65.7	73.1	87.9	95.7
	145	155	158	183	177
	61.4	65.3	72.7	87.4	95.2
	144	154	157	182	176
	61.0	64.9	72.2	87.0	94.6
	143	153	156	181	175
	60.6	64.5	71.8	86.1	94.1
	142	152	155	180	174
	60.2	64.1	71.3	86.1	93.6
	141	151	154	179	173
	59.8	63.7	70.8	85.7	93.1
	140	150	153	178	172
	59.4	63.4	70.4	85.2	92.6
	139	149	152	177	171
	58.9	63.0	70.0	84.7	92.1

1) When testing, engine, gearbox, final drive and tyres must be at operating temperature
 2) kg-data for Schenk roller test stand

Determining oil consumption

Measuring oil consumption is only possible after the car has covered approx. 7 500 km (5 000 miles). Until this distance has been completed, oil consumption will not yet have stabilised at its typical level. The engine must be oiltight before consumption is measured.

Drain the engine oil while at normal operating temperature.

Unscrew and empty the filter body.

Renew the filter element or discard and replace the throwaway cartridge.

Fill the engine with clean engine oil of the correct grade.

Drive the vehicle under normal operating conditions until the oil level has dropped to the lower mark on the dipstick. Measurement over a distance of only 500 to 1 000 km (300 to 600 miles) has proved to be inaccurate in most cases, since the first quantity of oil is consumed more rapidly than the remainder.

Engine oil consumption should not exceed 0.2 litre per 100 km (175 mile/pint (Imp.), 300 mile/US quart).

Possible causes of excessive oil consumption:

1. Engine running-in is still not complete.
2. Valve stem oil seals defective.
3. Piston seizure.
4. Piston rings installed incorrectly, worn or fractured.
5. Clearance between valve stem and valve guide is excessive.

Determining fuel consumption by the DIN 70030 German standard test method

The car's carburettor and ignition settings¹⁾ must be to standard specification.

Tire sizes must agree with the vehicle's registration papers.

Tire pressures should be corrected if necessary (see specified values).

Brakes must be fully released.

The engine should have been run for at least the equivalent of 7 500 km (app. 5 000 miles) and should be at normal operating temperature for the test.

While measuring fuel consumption, the car should be laden to halfway between the permissible gross (all-up) weight and the unladen (dry or kerb) weight.

Speed should be maintained as uniformly as possible over the test route, and should be 3/4 of the car's measured maximum speed, but should not exceed 110 km/h (68.4 mile/h).

The test route should be approx. 10 km (6.2 miles) long and as flat and dry as possible. It should be completed in both directions. Gradients (uphill or downhill) not exceeding 1.5 % (1 in 67) are acceptable.

The air temperature should be between 10 and 30° C (50 and 86° F) and the wind speed not more than 3 m (9.84 ft)/sec.

The vehicle should be run on a standard commercial grade of fuel (of the rating specified by the manufacturer).

Fuel consumption is then determined with a standard commercial meter or by using the following formula, and adding 10 % for unfavorable circumstances.

$$\frac{\text{Fuel consumed} \times 100}{\text{Distance covered (km)}} = \text{Fuel consumption (by standard test method)}$$

Fuel consumption in litres/100 km can be converted to Imperial or US miles per gallon as follows:

$$\frac{282.47}{\text{Value obtained}} = \text{Consumption in Imp. mile/gal}$$

$$\frac{235.2}{\text{Value obtained}} = \text{Consumption in US mile/gal}$$

¹⁾ See specifications

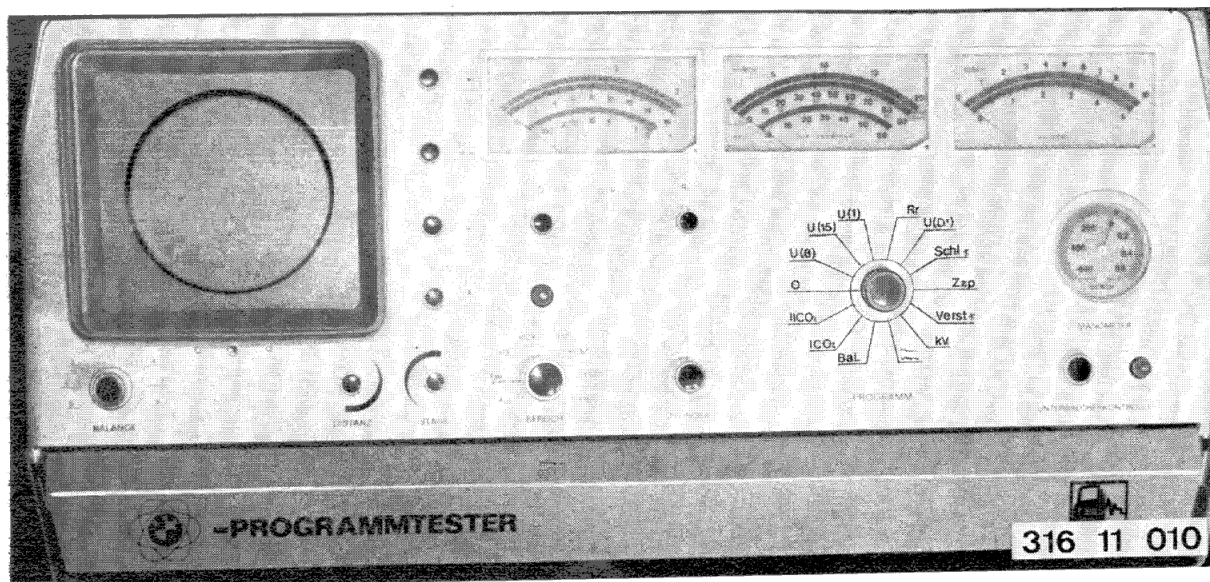

11 00 009 BMW Program Engine Test

Switch positions	Item tested	Page
	Program Tester – connecting	11-00/3
U (B +)	Battery voltage without consumers	00/4
U (15)	Voltage at coil terminal 15	00/4
	a) coil offload current	
	b) when starting	
U (1)	Voltage drop at contact breaker and plug connections	00/4
Rr	Condenser – distributor	00/5
U (D +)	Alternator and regulator – checking	00/8
Schl ↙	Dwell angle	00/8
	Cam displacement – distributor	00/8
	Contact breaker points	00/9
	Coil polarity	00/9
	Condenser – distributor	00/10
Zzp	Ignition timing	00/10
Verst ↙	Centrifugal advance/retard	00/11
	Vacuum advance/retard	00/11
KV	Image adjustment on oscilloscope (basic trace)	00/12
	Ignition voltage – HT insulation	00/14
	Cylinder comparison (vertical display)	00/18
Bal	Power output comparison between cylinders	00/20
I CO %	CO measurement – idle speed (% by volume)	00/21
Test values	Fuel pump pressure – float needle valve	00/22
	Additional test	00/23

Connecting the Program Tester.

Connect Program Tester to the central plugs (1 and 2).

Warning: Do not insert plug the wrong way round.

Note stepped section on plug.

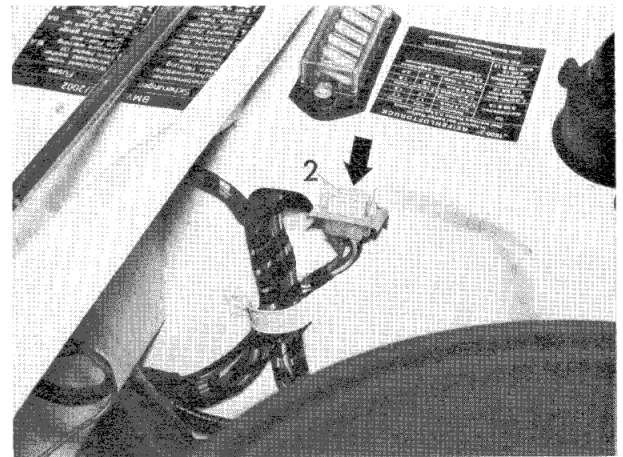
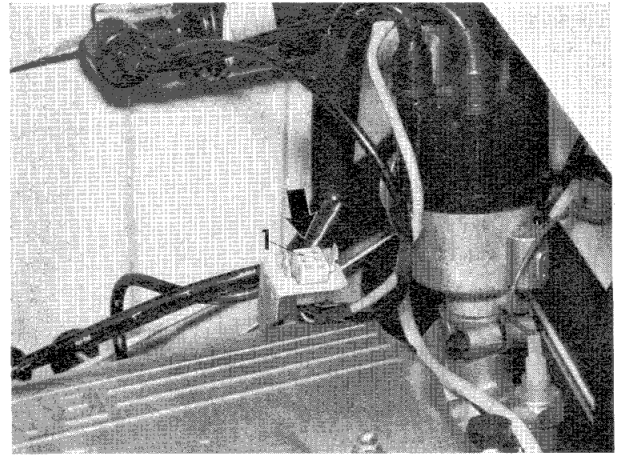

Vehicles which do not have central plugs must be connected as follows:

Connect large contact (A) to ignition lead between coil and distributor.

Connect small contact (B) to ignition lead to cylinder 1, as close as possible to the distributor.

Connect test lead 15 to the input side of the coil or series resistor. 1 to coil terminal 1.

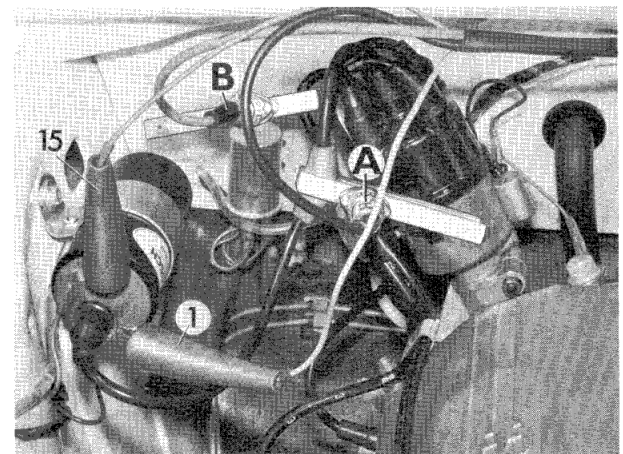

B + to battery +
to engine block

50 to starter terminal 50

D + to alternator D + or regulator D +.

Connect regulating valve for vacuum between carburettor and distributor.

Connect pressure hose with T piece between carburettor, fuel pump and changeover tap.

Connect changeover tap for pressure/vacuum between regulating valve and pressure gauge.

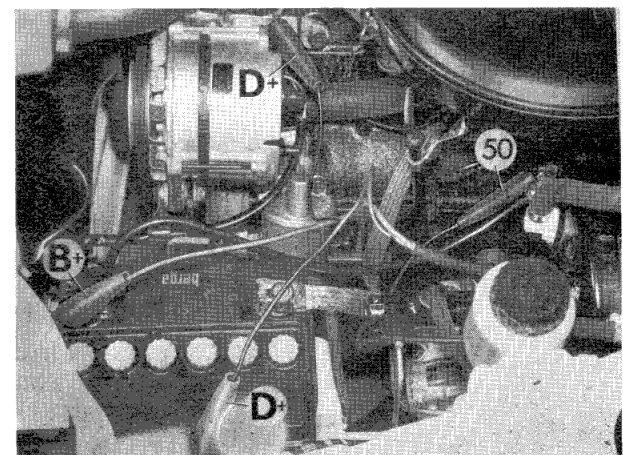

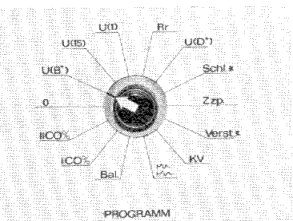

Switch position U (B+)

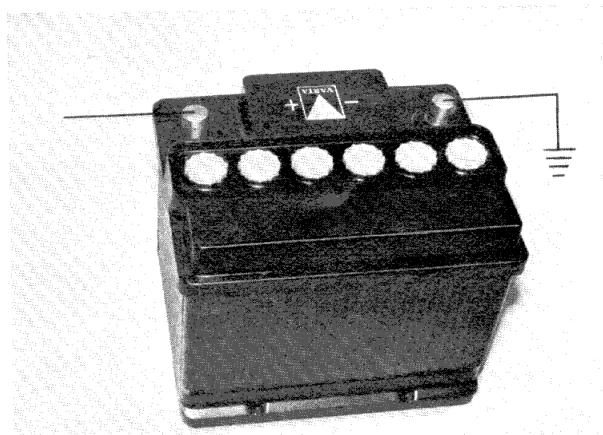

Battery voltage without current consumers¹⁾

Measure battery voltage with all current consuming items of equipment switched off. Engine stopped and ignition switched off.

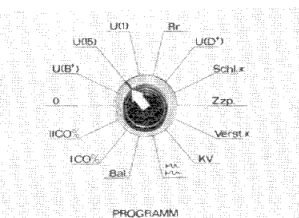

Switch position U (15)

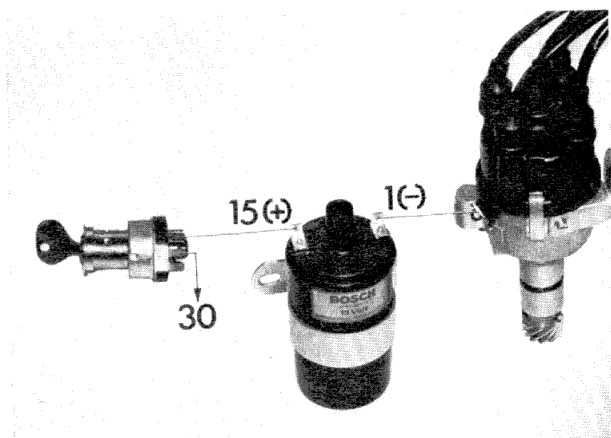

Voltage at coil terminal 15

For this measurement, the program switch short circuits the contact breaker points. Do not use the remote control device of the tester.

- a) Coil offload current:
Switch on the ignition, measure voltage¹⁾ at coil under coil offload current loading.
- b) Starting the engine¹⁾:
check voltage at coil when starter motor is operated.

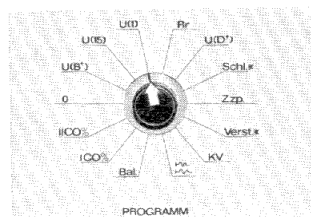

Switch position U (1)

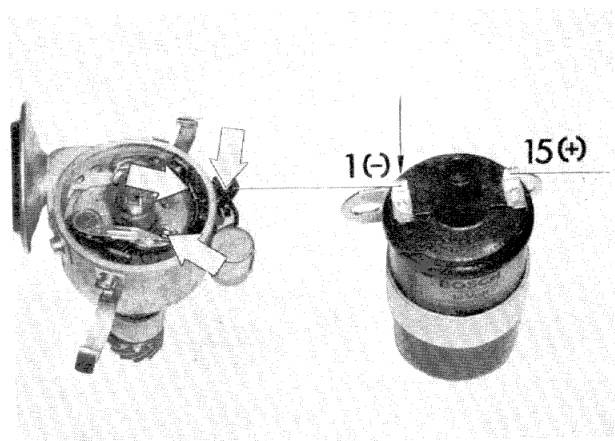

Voltage drop at contact breaker and connecting terminals¹⁾

Press the 'Contact breaker check' switch. The green warning lamp should light up. If this is not the case, operate the starter until the green lamp burns. Read off the voltage drop¹⁾.

¹⁾ See test values

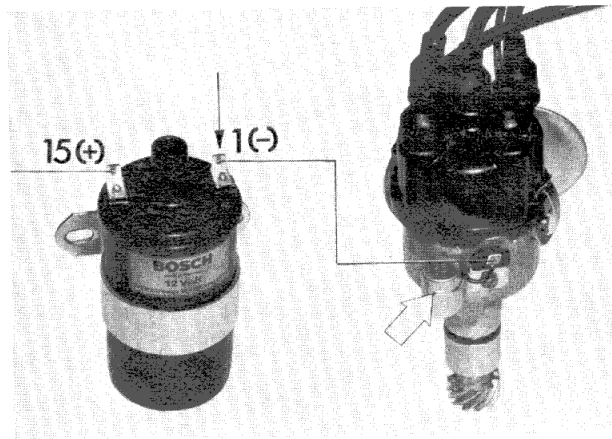

Condenser - distributor/series resistance

Insert a plastic strip (free from grease) between the contact breaker points.

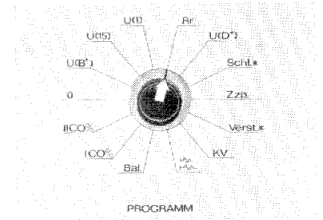

Switch position Rr

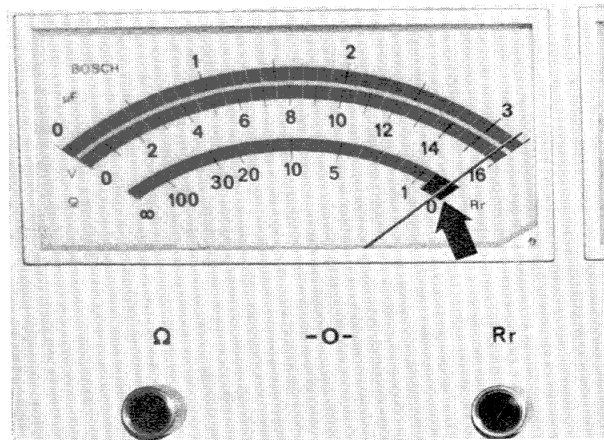

Press the contact breaker checking knob. The green warning lamp must light up. (Breaker points open.) With the knob pressed, set zero on the lower Rr scale by means of rotary knob Rr. Release the press button. If the reading is within the broad area on the scale, the condenser is in good working order.

Warning: A series resistance at the condenser has the effect of retarding the ignition. The fault must be traced and rectified before timing the ignition.

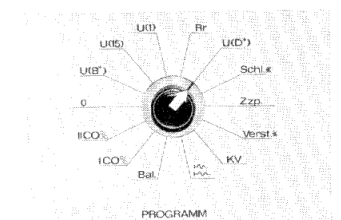
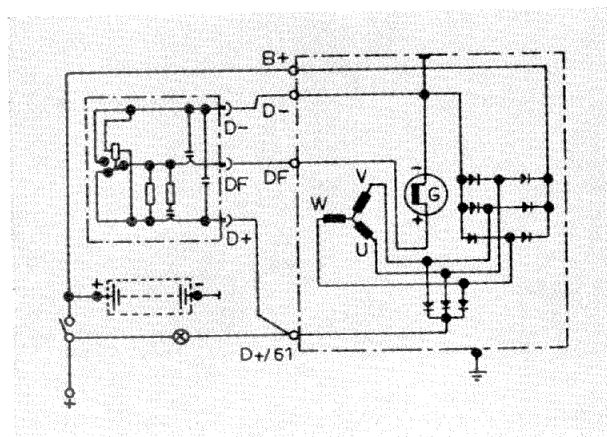

Switch position U (D+)

Checking alternator and regulator

All tests to be made at engine speed 900 rpm.

Warning: While testing with the engine running, the plug connection between the alternator and the regulator must not be removed.

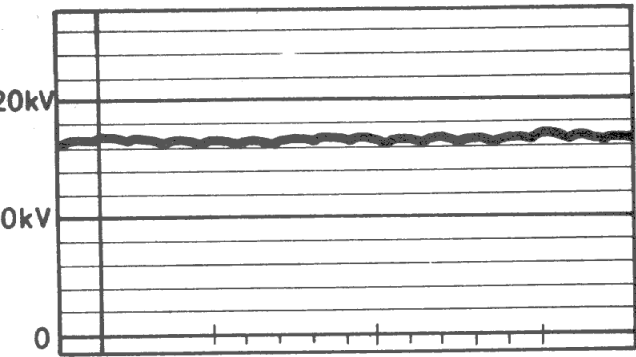

Alternator functioning correctly.
Stop heterodyning of oscillogram by
switching on headlamps.

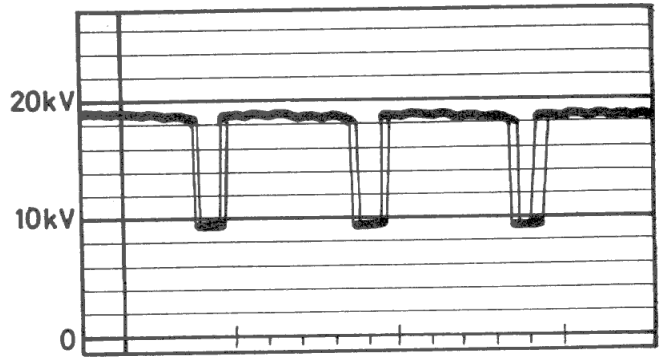

One exciter diode interrupted.

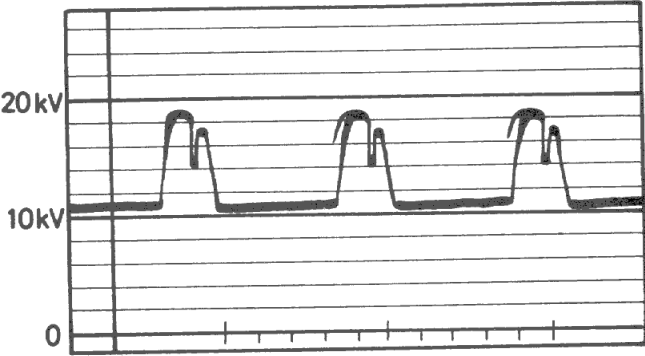

Positive diode interrupted.

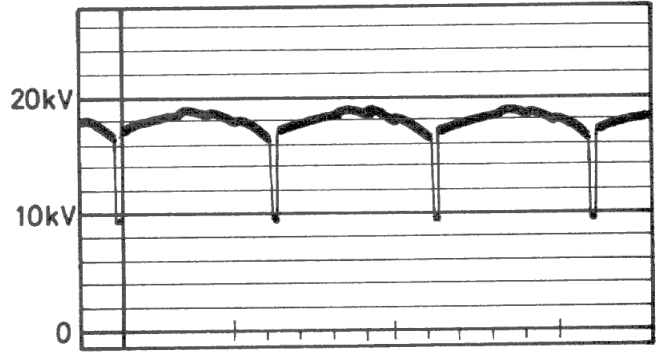

Negative diode interrupted.

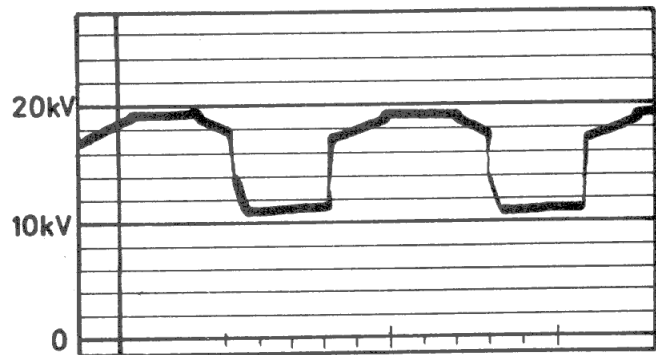

Exciter diode short circuited.



Positive diode short circuited.

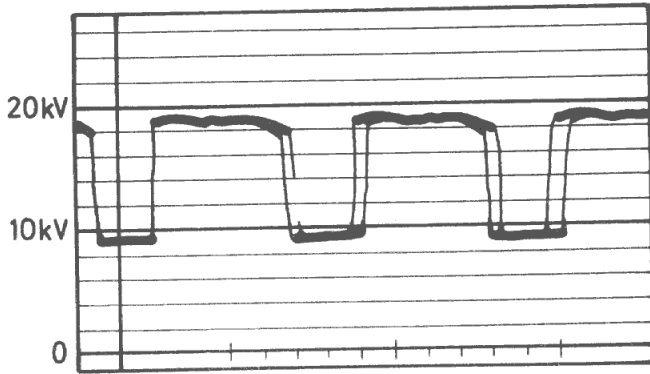

Negative diode short circuited.

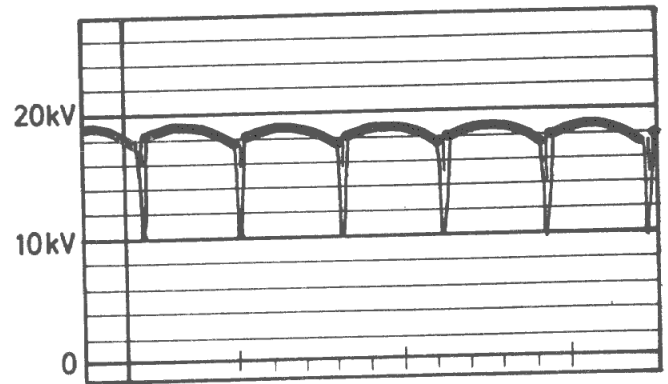

Phase error.

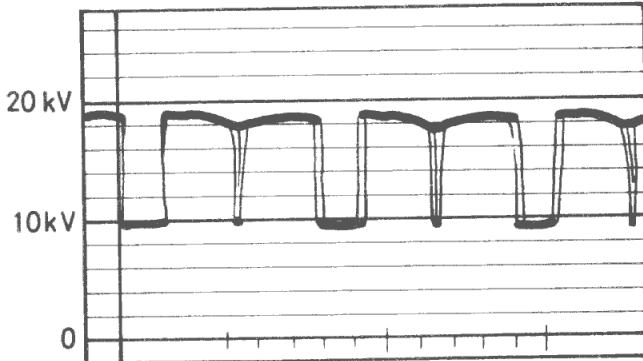

Phase error and short circuited negative diode.

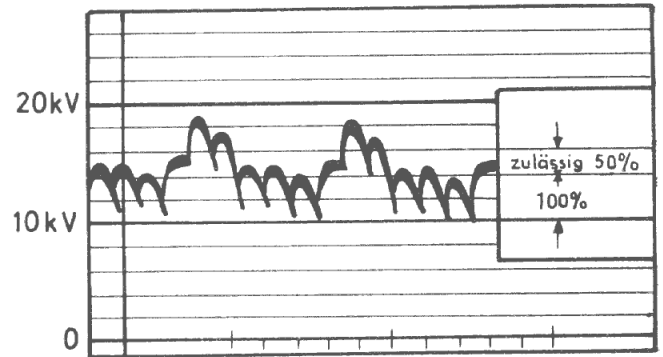

Diode with non-standard characteristic.

Warning: Deviations of less than 50% are still acceptable. If the deviation is larger, the defective diode must be renewed.

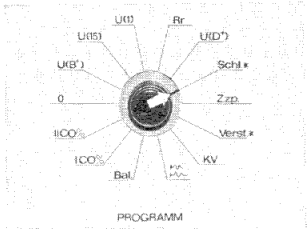

Switch position Schl. \sphericalangle (dwell angle)
 Engine speed 2000 rpm

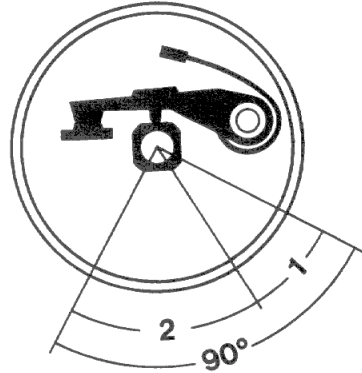
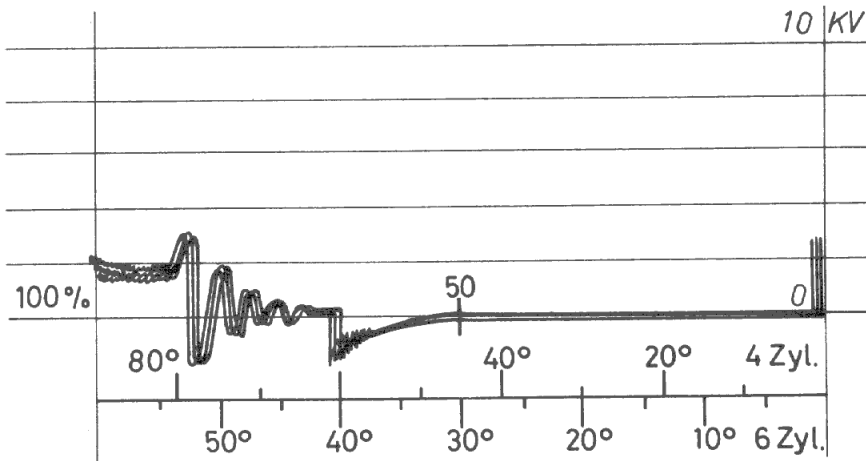

Open angle (1).
 Measure the dwell angle¹⁾ (2) in degrees. Adjust dwell angle (2) to minimum value.

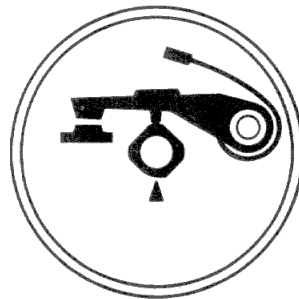
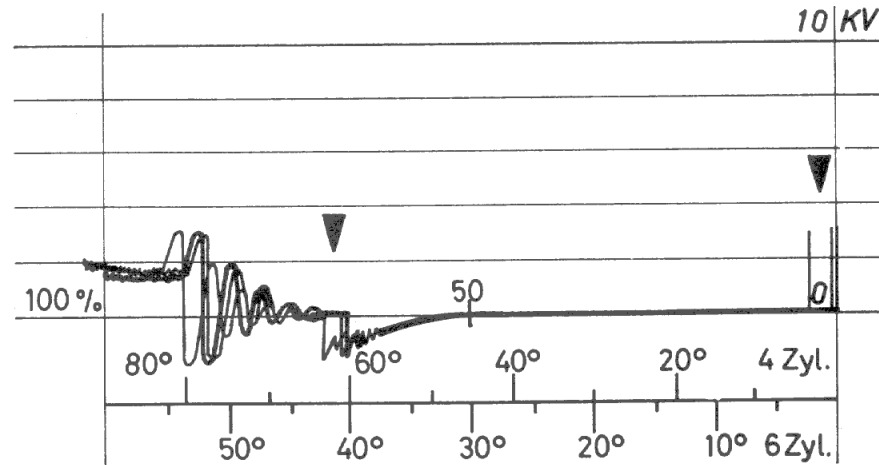

Cam displacement in distributor:

The ignition traces of all cylinders are superimposed.
 The accuracy of the distributor determines the regularity of the pattern of ignition traces in sequence.

The size of the cam displacement¹⁾ can be read off by means of the graduated scale.

Worn cams, runout distributor shafts or a loose contact plate can cause changes in the dwell angle and points gap.

For reconditioning, see 12 11 572 'Distributor – overhauling'.

¹⁾ See test values

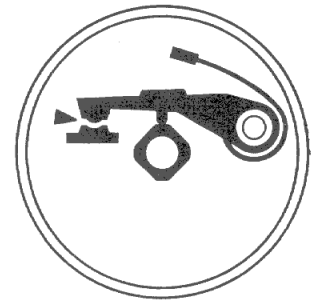
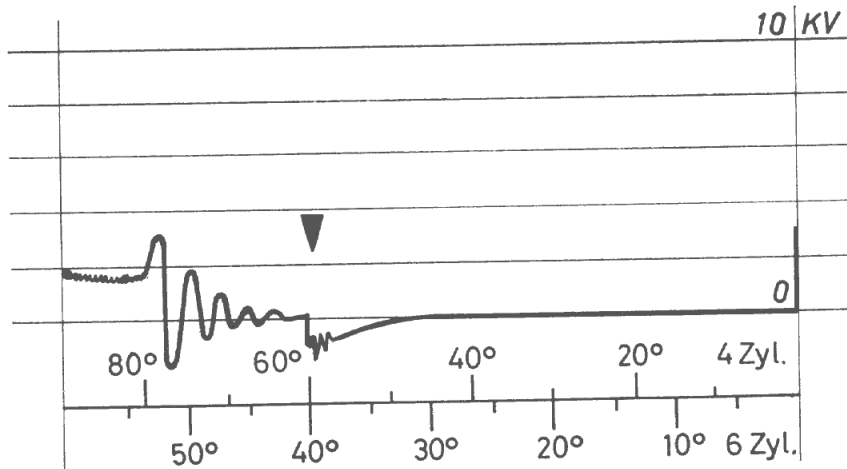

Dirty or eroded contact breaker points

If the breaker points are dirty or eroded, the build-up of the magnetic field is delayed. This error can be seen on the oscilloscope as a distortion of the start of the decay section of the trace.

Replace the breaker points.

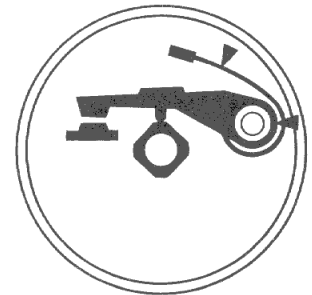
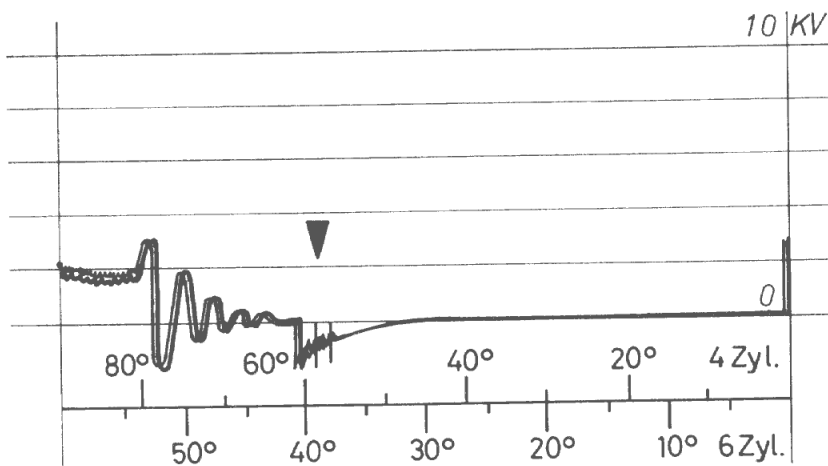

Contact breaker points bounce

If the springs which close the breaker points are worn, points bounce may occur. The moving contact springs back after closing and a second interruption in current flow of short duration is caused.

Replace the breaker points set.

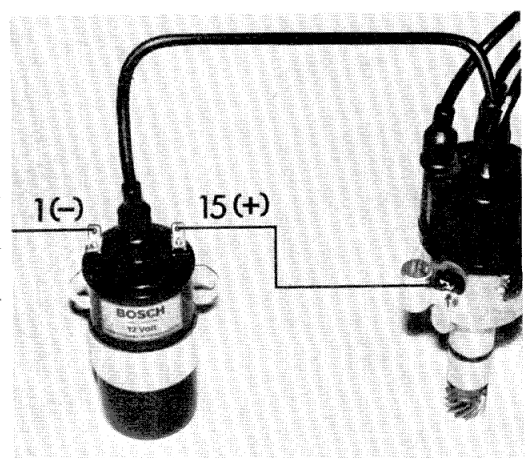
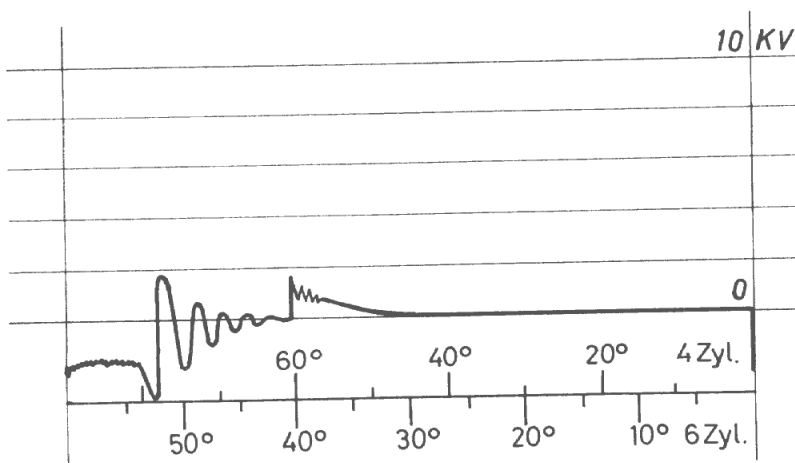

Incorrect coil polarity

The leads to terminals 15 (+) and 1 (-) on the coil have become interchanged.

Connect the leads to the correct terminals. This instruction refers to the leads on the car, not those on the tester.

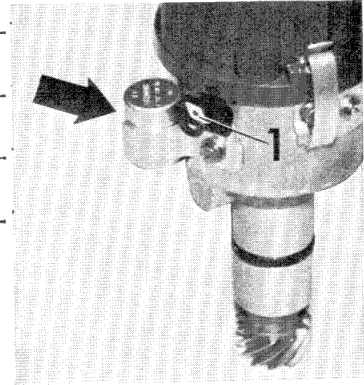
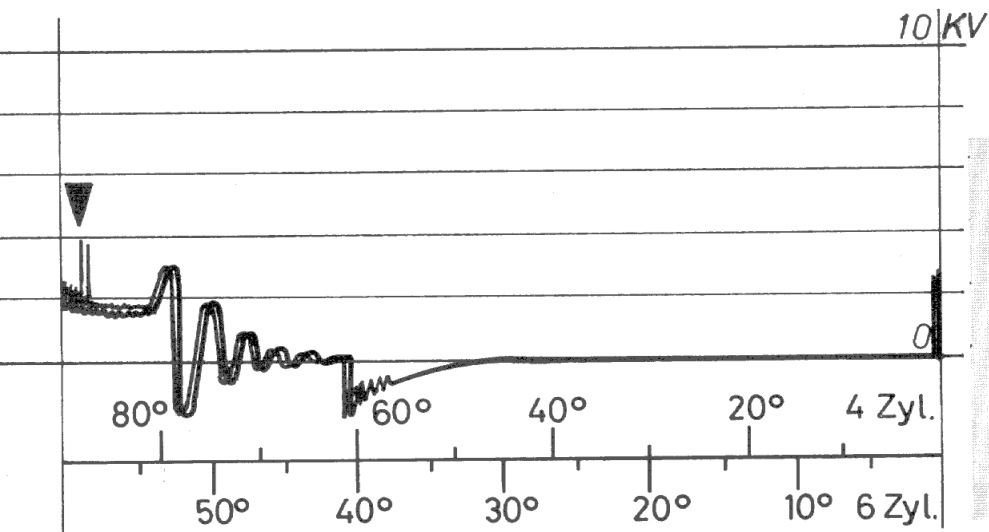

Condenser — distributor/series resistance

If a condenser series resistance is present, the result will be contact breaker points burning, visible as a blue tinge and as transfer of the points material from one contact to the other.

Warning: A condenser series resistance results in retarded ignition. The fault must be rectified before the ignition is timed. Replace the condenser and the breaker points.

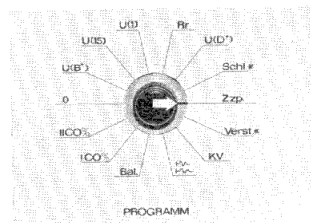

Switch position: Ignition timing

Engine speed 1)

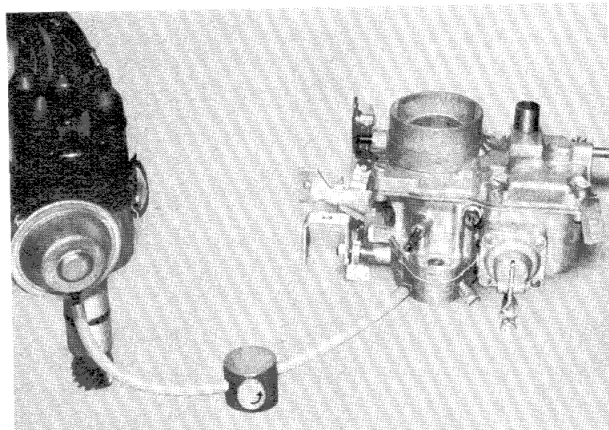

Dynamic adjustment of ignition timing (engine at normal operating temperature):

Regulating valve for vacuum tester must be open.

When regulating valve is open, the vacuum pipe to the distributor is interrupted.

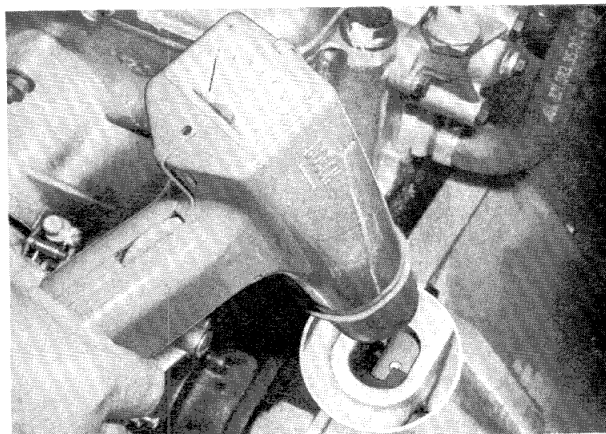

Illuminate ball mark on flywheel.

Warning: Watch for change in engine speed while adjusting. Ignition timing is correctly adjusted when the centre of the ball is visible at the edge of the inspection hole.

1) See test values.

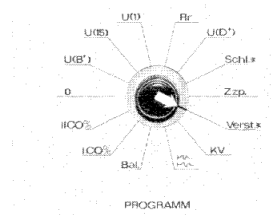
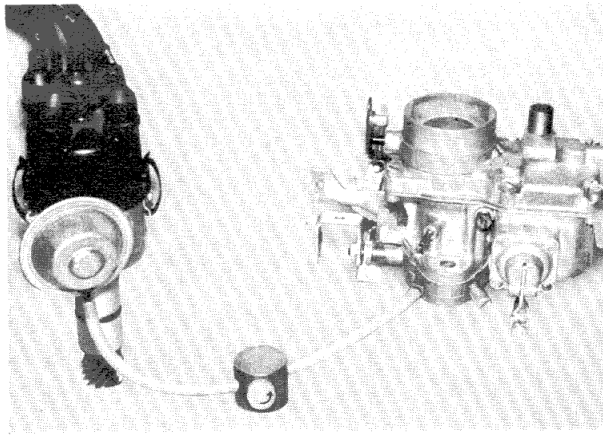

Switch position: Angle of advance \times

Centrifugal¹⁾

Engine at normal operating temperature.
 Open regulating valve for vacuum tester. When the regulating valve is open, the vacuum line to the distributor is interrupted.
 Set correct engine speed¹⁾,

Turn the thumbwheel (1) on the timing light until the OT (TDC) mark on the flywheel and the edge of the inspection hole are aligned when illuminated.
 Read off the angle of advance¹⁾ in degrees of crankshaft rotation on the meter (2).
 If incorrect values are obtained, replace the distributor.

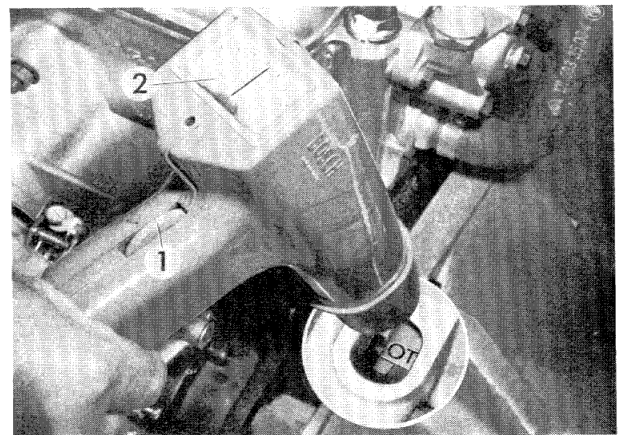

Vacuum advance¹⁾

Close the regulating valve for the vacuum tester.
 Set engine speed to the value giving maximum vacuum advance.
 Turn the thumbwheel (1) on the timing light until the OT (TDC) mark on the flywheel and the edge of the inspection hole are aligned when illuminated.

Slowly open the regulating valve for the vacuum tester.
 If the OT (TDC) mark appears to move in the 'retard' direction, the end of the vacuum advance range has been reached.
 Correct any change in engine speed.

Turn the thumbwheel (1) on the timing light until the OT (TDC) mark on the flywheel and the edge of the inspection hole are aligned when illuminated.
 Read off the angle of advance, e.g. 31°.

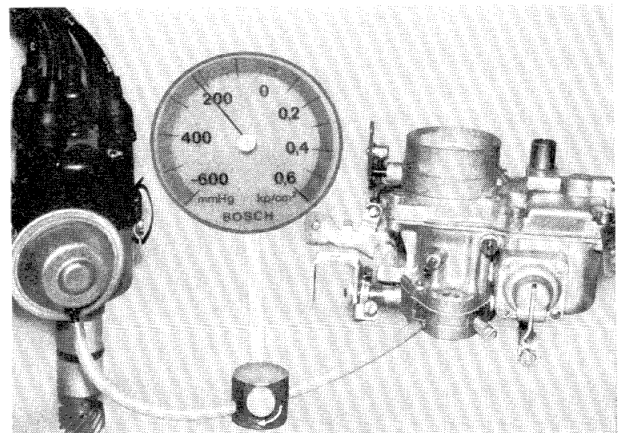

Example:

Angle of advance with regulating valve (A) closed	41°
Angle of advance with regulating valve (A) open	31°
Vacuum advance ¹⁾	<u>10°</u>

Close the regulating valve slowly until the OT (TDC) mark moves in the 'advance' direction.
 The vacuum shown at this point indicates the start of the vacuum advance range.¹⁾

¹⁾ See technical data.

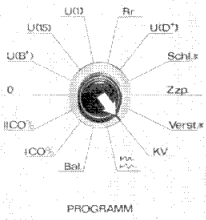

Switch position KV
Engine speed 1200-1400 rpm

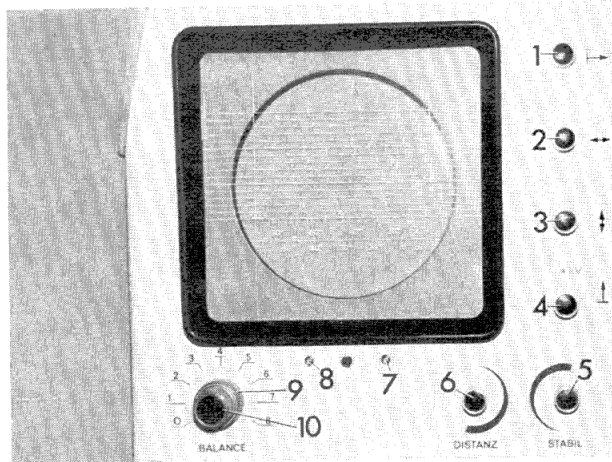
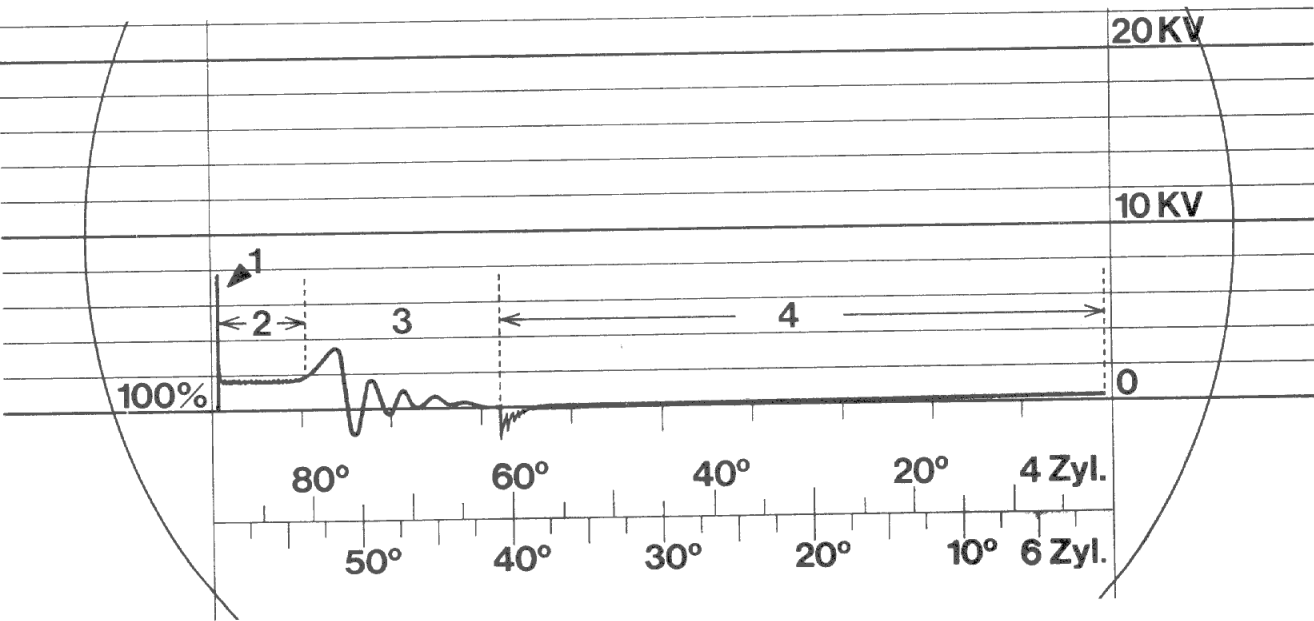

Image setting on oscilloscope:

- Set balance switch (9) to 0.
- 'Distance' knob (6) must be turned fully to left.
- With knobs \leftarrow (2) and \rightarrow (1), set image width of all cylinder traces between 0° and 60° .
- Set image to zero line with \updownarrow control (3).
- Knob \updownarrow KV (4) must be fully to left.
(Zeroing setting for ignition voltage measurement in KV.)



Basic trace EXTERNAL

This oscillogram shows the progress of the ignition voltage for a single cylinder of the engine, with the ignition system functioning normally. The basic trace can be divided into 4 sections.

Ignition voltage peak (1), combustion voltage line (2), decay oscillations (3) and closed phase (4).

Ignition voltage peak (1)

The ignition voltage peak occurs at the moment when the contact breaker points open. It represents the ignition voltage, which rises rapidly until the spark jumps the plug gap, and then drops immediately afterwards to the combustion voltage level as a result of voltage equalization caused by the spark.

Combustion voltage line (2)

The combustion voltage line represents the ignition voltage during the remainder of the spark life, as it continues to glow.

Decay oscillations (3)

As soon as the energy in the coil no longer is sufficient to maintain the spark, it breaks off sharply and the residual energy is seen on the screen as decay oscillations.

Closed phase (4)

The contact breaker points are closed during this phase.

Any deviation from this basic trace indicates a fault in the ignition system.

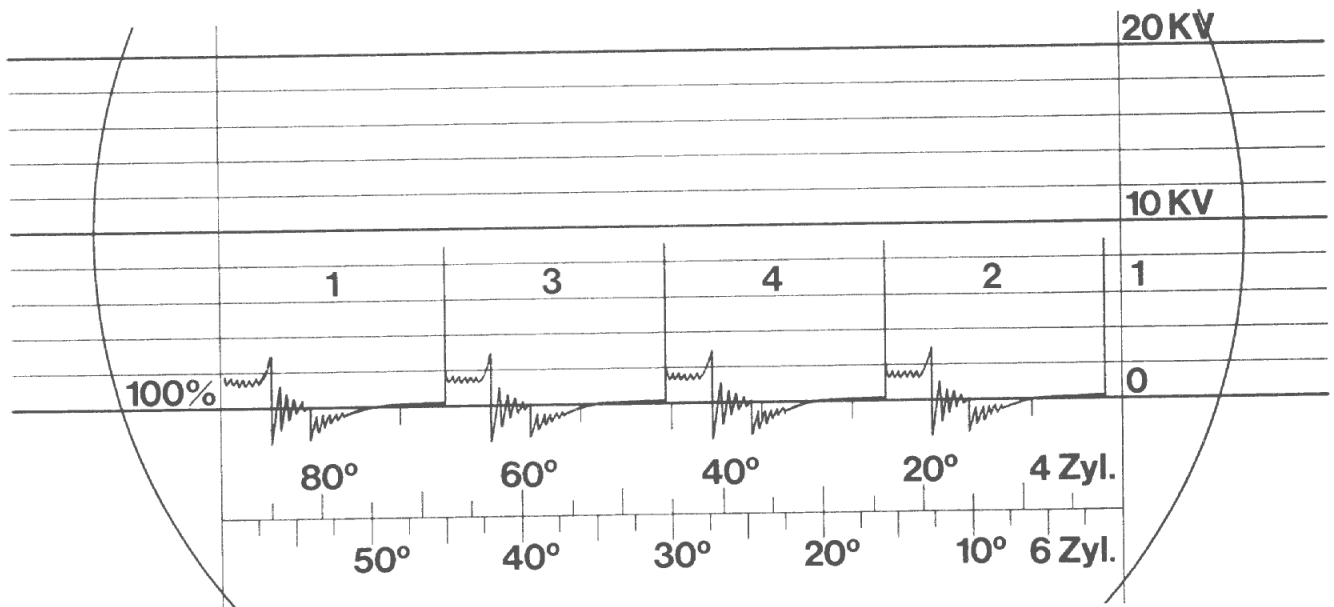

If basic trace **EXTERNAL** is selected, the individual cylinder traces will appear in sequence, next to one another.

This gives a general picture of the condition of the complete ignition system.

The traces appear in the normal engine firing order from left to right on the screen.

The only exception to this is the ignition voltage peak for cylinder 1, which is on the far right.

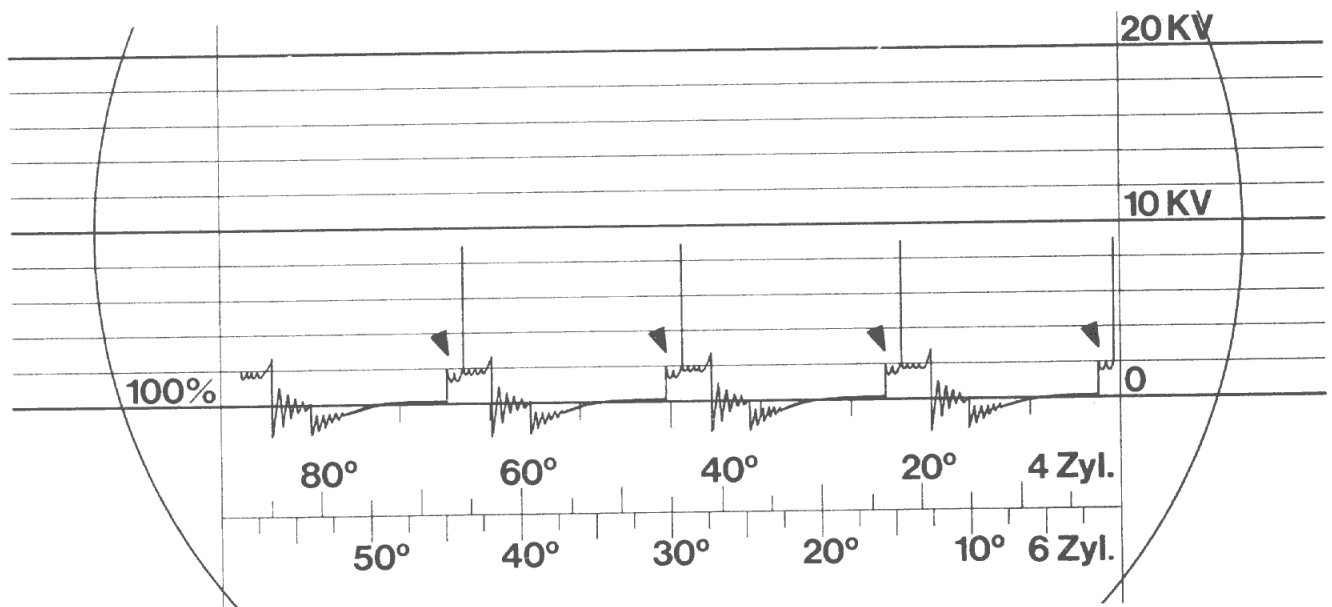

Condenser series resistance

A step will be visible in the ignition voltage peak.

Any resistance in circuit between the condenser earth (ground) and the distributor earth (ground), or between the plates of the condenser and the connecting lead, will adversely affect ignition performance and the service life of the breaker points (visible as blue discoloration).

Warning: A condenser series resistance will result in retarded ignition. For this reason, always trace and rectify the fault before timing the ignition.

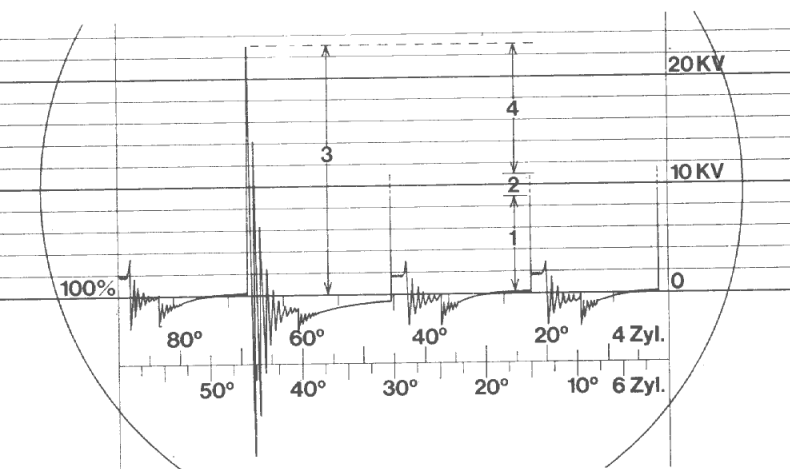

Engine running at idle speed.
 Note height of ignition voltage peak (1).
 Accelerate suddenly.
 The ignition voltage peaks for all cylinders
 must rise at the same time.

The difference between cylinders must not exceed 2 KV.

To check coil offload voltage, pull off any plug lead. If the HT insulation is in good condition, a large amplitude damped oscillation will be seen (3). The coil offload voltage should be at least 30% above the ignition voltage peak (2). The difference in height between the ignition voltage peak (2) and the maximum oscillation amplitude (3) is the ignition voltage reserve.

Ignition voltage and ignition voltage reserve:

- 1 Ignition voltage with engine running.
- 2 Increase when accelerator is suddenly opened.
- 3 Coil offload voltage (with plug lead removed).
- 4 Ignition voltage reserve.

If the trace on the oscilloscope jumps from side to side, the small sensor contact must be moved nearer to the distributor.

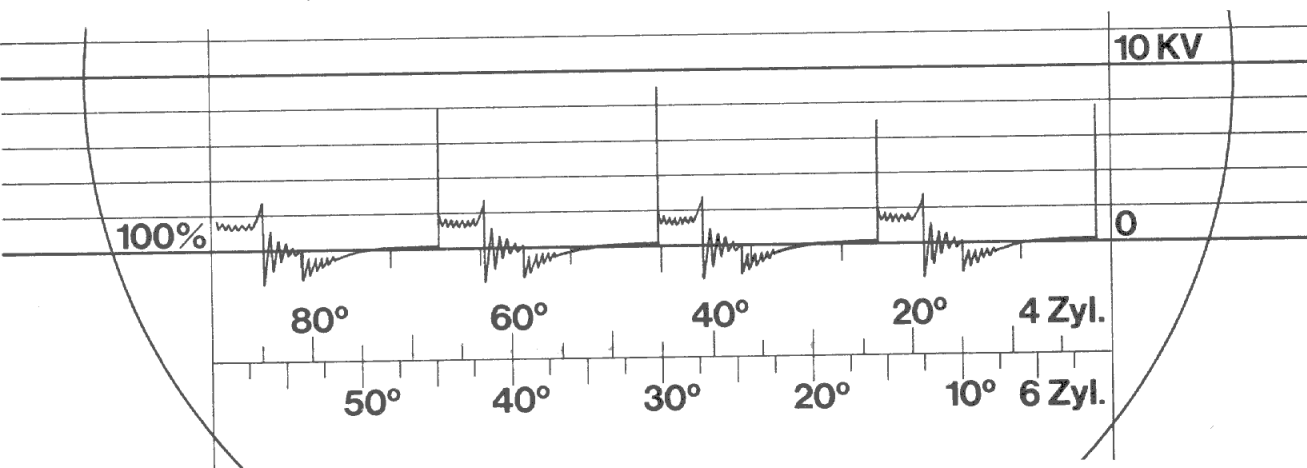

Differences in ignition voltage

Rotary knob \uparrow KV must be fully to the left.

Measure the ignition voltage in KV with the oscilloscope. Uniform values for all cylinders are more important than maximum voltage.

Differences of up to 2 KV are acceptable. If larger, check:

- a) Synchronizing¹⁾ and mixture settings of carburetors

Factors affecting ignition voltage requirement	Ignition voltage too high Cause	Ignition voltage too low Cause
b) Spark plug gap ²⁾	too large	too small
c) Compression	too high	too low
d) Mixture preparation	too weak	correct
e) Ignition spark polarity	incorrect	correct (negative)
f) Plug electrode temperature (engine temperature)	too low	too high
g) Electrode material ²⁾	unfavorable alloy	pecially selected alloy
h) Electrode pattern ²⁾	round section	sharp edged
j) Electrode condition ²⁾	eroded	new
k) Ignition timing	retarded	advanced
l) Ignition leads	interrupted	—
m) Tracking in distributor	heavy	—

1) Only on 2002 T1 2) Depending on type of spark plug used.

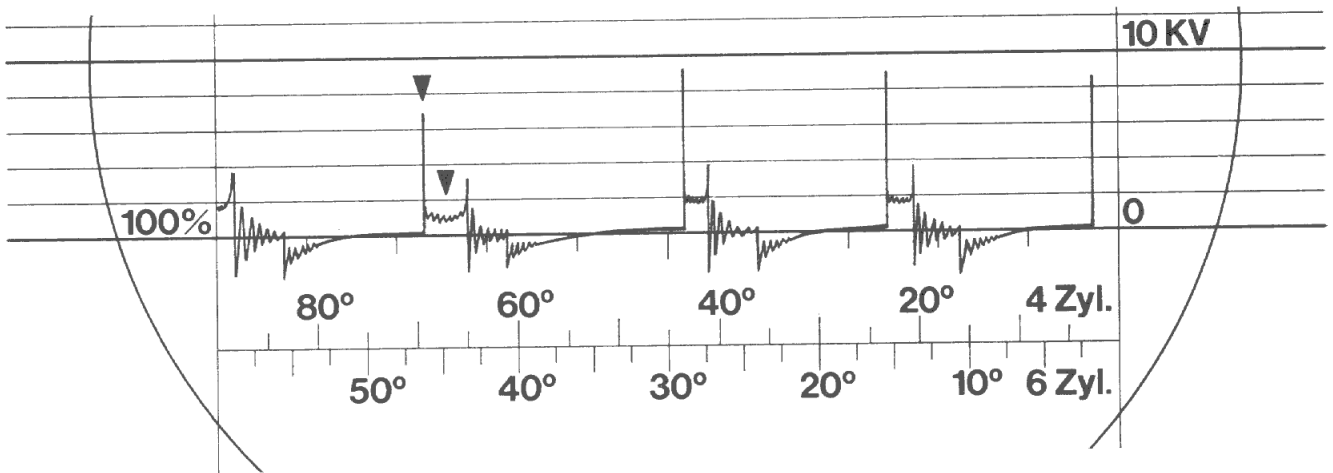

Defective HT insulation:

Ignition voltage peak is lower.

The combustion voltage line is also positioned lower, and is broader.

Check HT insulation of coil, leads, distributor cap and spark plugs for cracks and potential leakage paths.

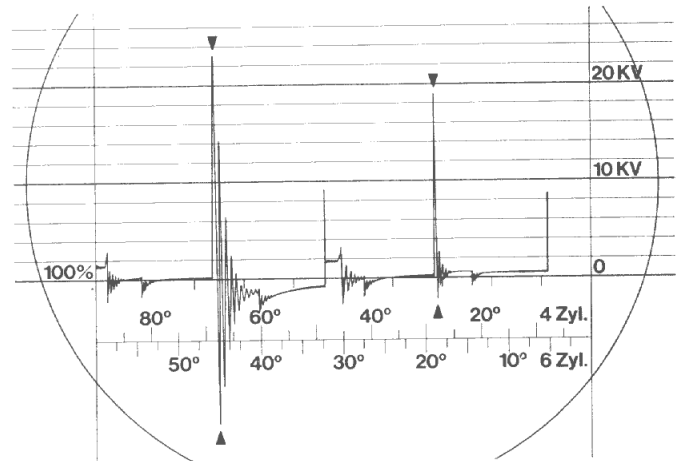

Precision insulation test:

Remove the spark plug leads one after another.

Cylinder 3 as shown here has insulation in good condition.

Cylinder 2: insulation defective.

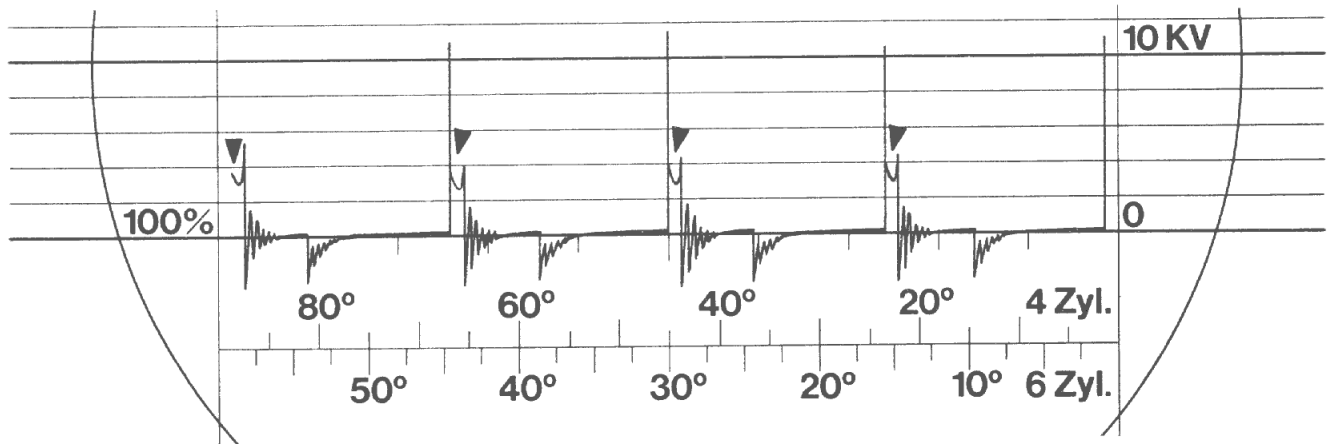

Defect affects all cylinders – suppressor resistors

Suppression resistor between coil¹⁾, distributor or distributor rotor¹⁾ has too high a resistance.

The combustion voltage line will slope and is narrower.

Suppression resistors which read uniformly too high or are defective for the individual cylinders from distributor cap to spark plug may have been caused if a radio was subsequently installed and incorrect suppression resistors used.

Excessively high resistance will be noticed when driving the vehicle as sluggish acceleration and inadequate engine output.

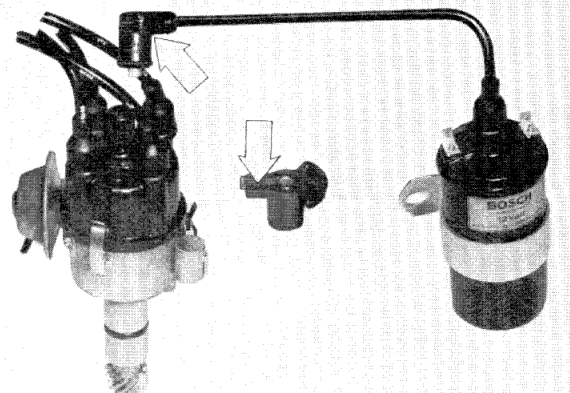

¹⁾ see test data

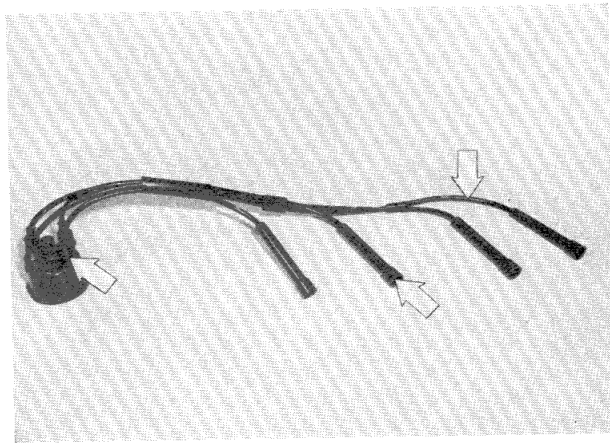
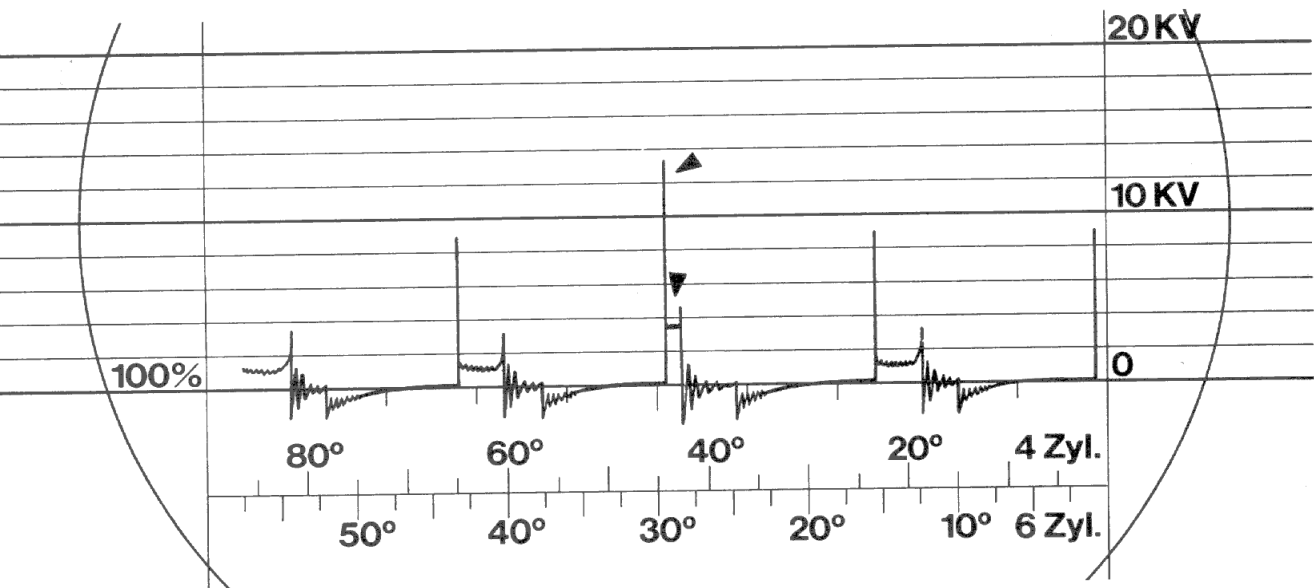

Ignition voltage peak is higher, combustion voltage line lies higher and is narrower.
 Fault on one cylinder: ignition lead interrupted, no current flow at plug cap or suppressor cap.
 Fault on all cylinders: Cause located between coil and distributor.

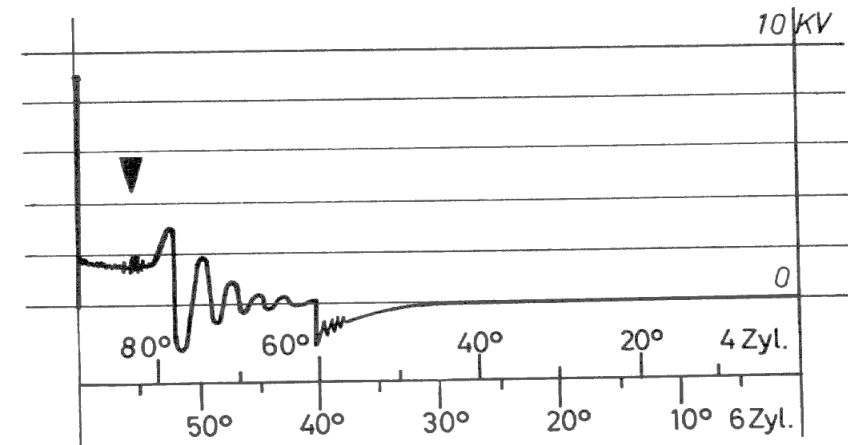

If the spark plugs are severely sooted, the combustion voltage line appears thicker and contains small amplitude superimposed oscillations.

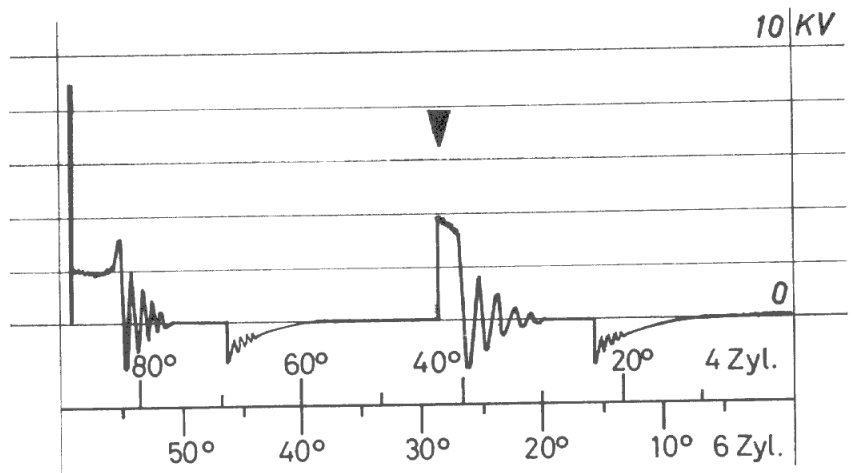

If the spark plugs are severely leaded (lead in fuel), the ignition current will be diverted when the engine is warm over the lead deposits, which then become electrically conductive. This results in misfiring.

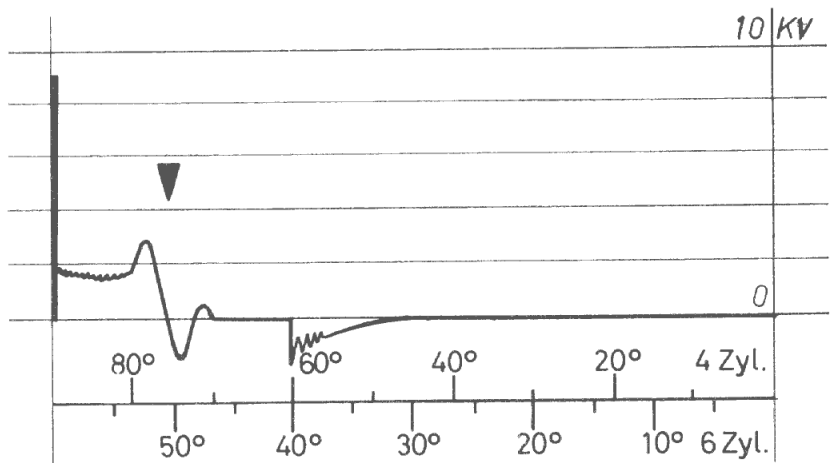

Condenser on distributor has a short to earth (ground) if the insulation resistance is below $2\text{ K}\Omega$. If the short is complete the engine will not run.

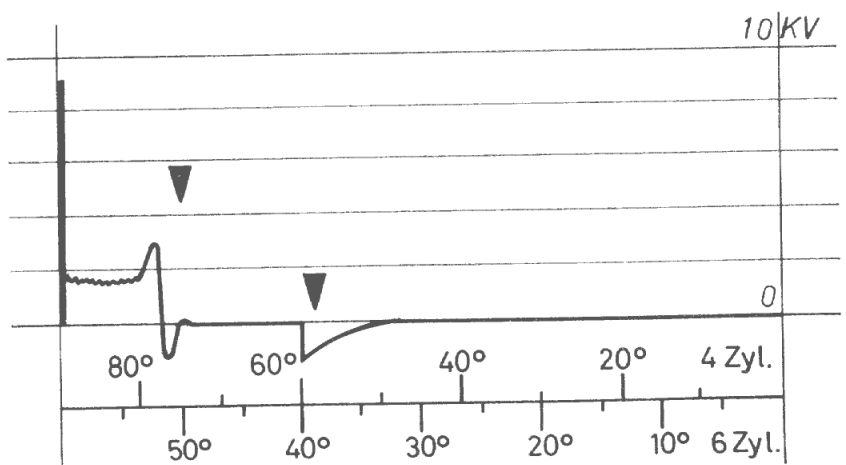

Short in coil primary winding

This reduces the ignition output, increases current consumption and accelerates breaker points wear. An interruption to the secondary winding will also result in reduced ignition output.

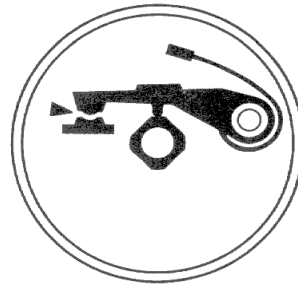
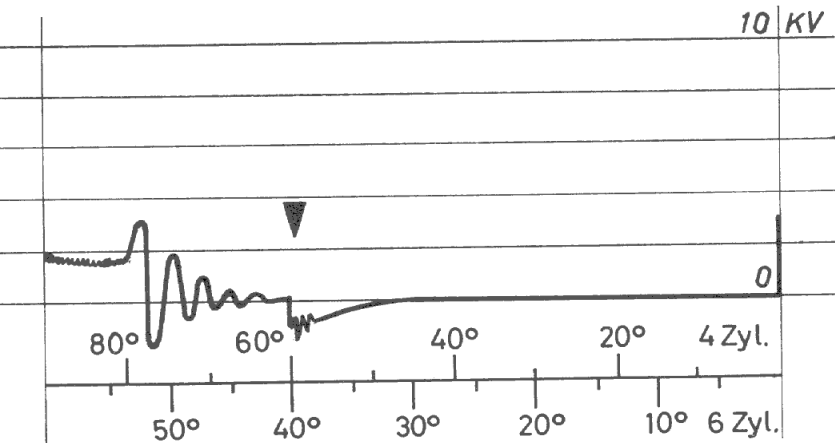

Dirty or eroded contact breaker points:

If the breaker points are dirty or eroded by burning, the magnetic field will not build up quickly enough. The oscilloscope indicates this fault as a deformation at the start of the closed phase.

Replace defective contact breaker points.

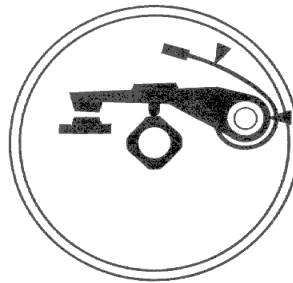
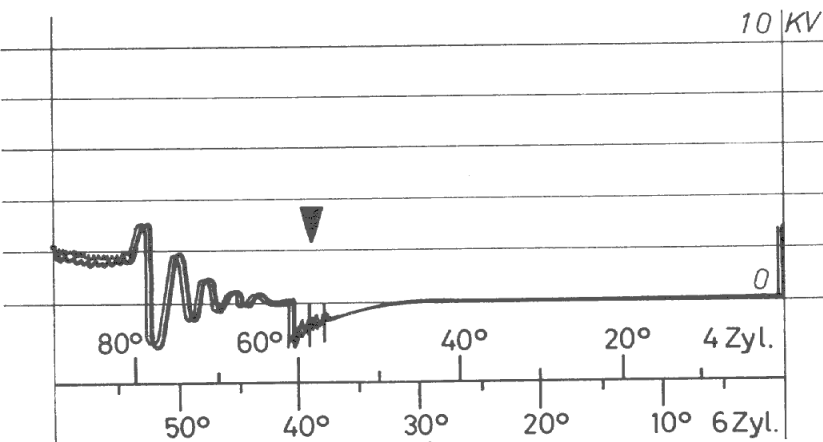

Contact breaker bounce:

If the breaker springs are not in perfect condition, contact bounce may occur. The moving breaker point rebounds after closing, and a further short-term interruption to the current flow results.

Replace contact breaker set.

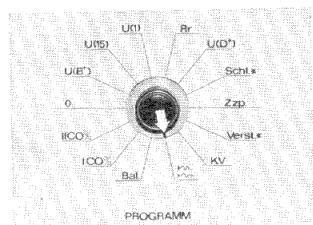

Cylinder comparison — traces superimposed

Set balance switch to 0.
 'Distance' knob must be turned full to left (positive stop).
 Cylinder selector switch must be set to number of cylinders in engine.
 Use rotary controls ←→ and ↕ to set image width between 0 and 60°.
 Set image on zero line with ↕ control.
 Adjust image height with ⬆️ KV control.

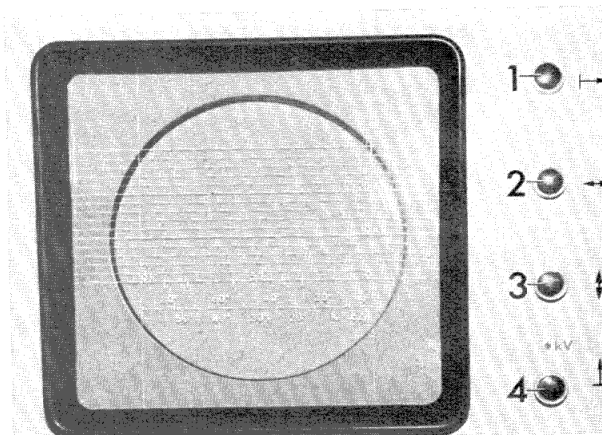

- 1 — Image width
- 2 — Horizontal displacement
- 3 — Vertical displacement
- 4 — Image height KV zeroing for ignition voltage measurement (rotary knob fully to left)

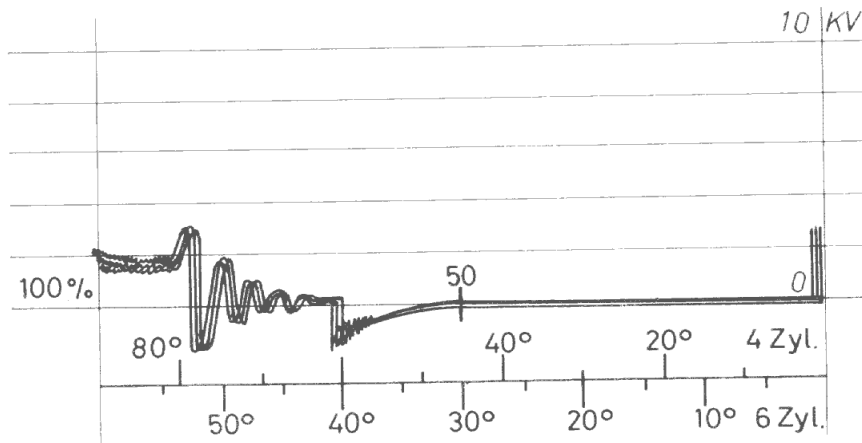

The ignition traces for all cylinders are superimposed for comparison.

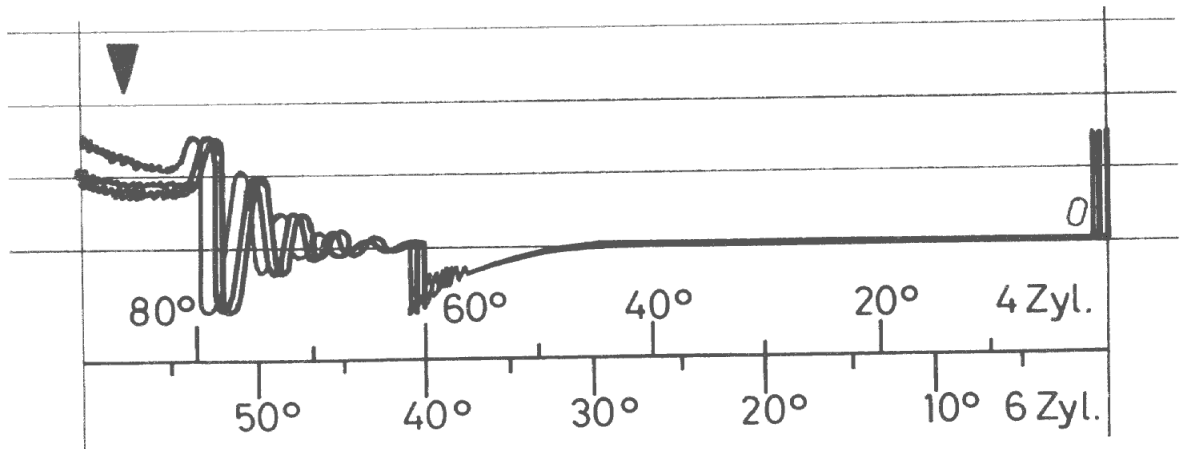

Here a suppressor resistor for one of the cylinders is defective.
Use the balance switch to adjust the individual cylinders in firing order.

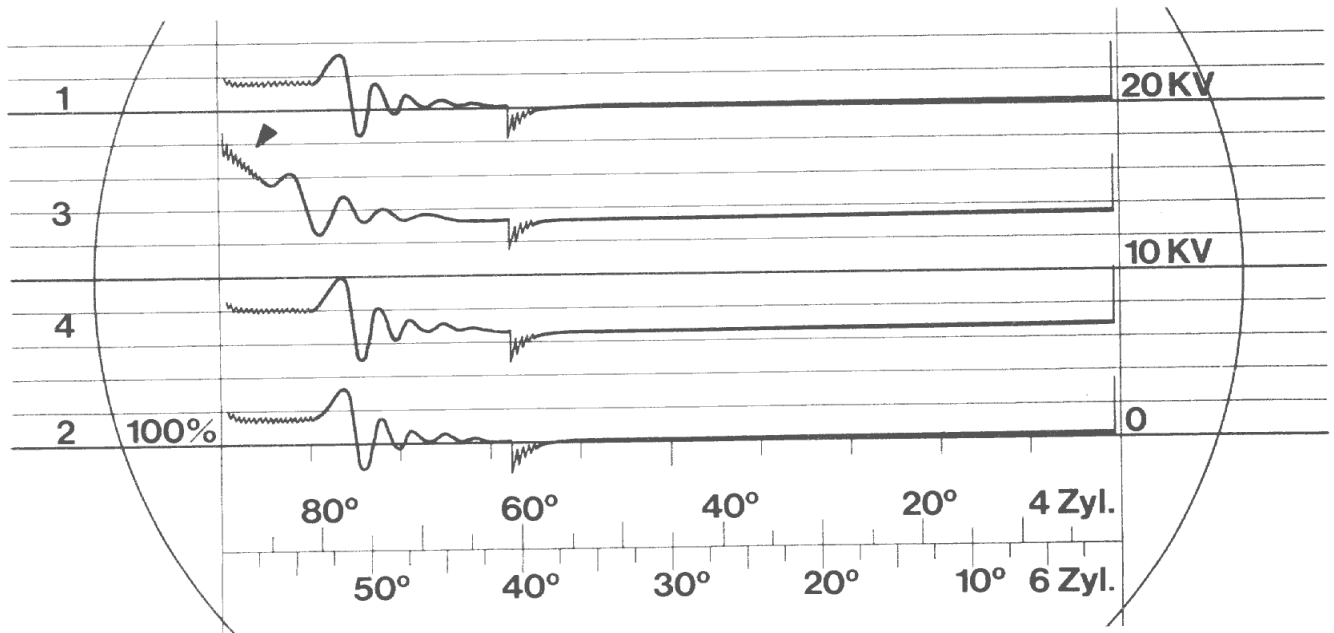

Return the balance switch to 0.

Turn the distance knob to the right until all cylinders are on the screen. For comparison, the ignition traces for each cylinder are now displayed one above the other.

The suppressor resistor for cylinder 3 is reading high.

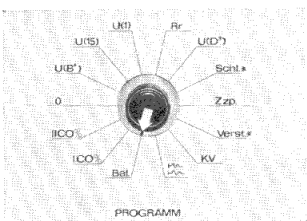

Adjusting image on oscilloscope:

Set cylinder selector switch to the number of engine cylinders.

Using rotary controls ◀▶ and ▶, set image width for all cylinders between 0° and 60°.

Switch position: Balance
 Engine speed 1500 rpm.

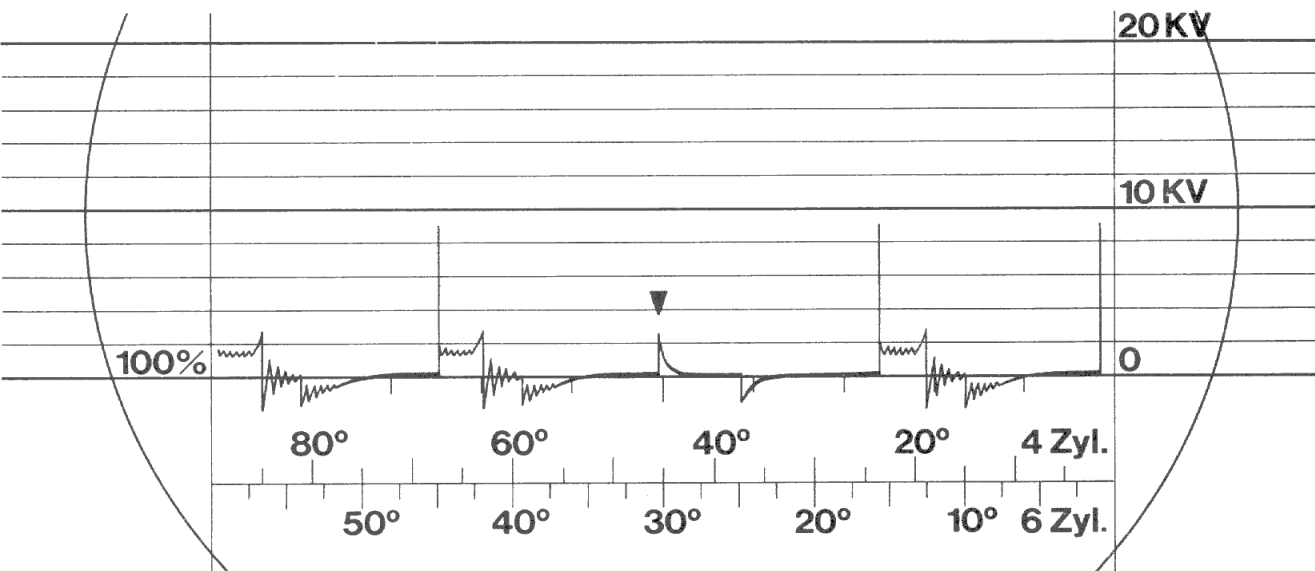

Comparison of cylinder power outputs:

Warning: Before this test can be made, the carburetors must be correctly synchronized¹⁾ and the idle mixture correctly adjusted.

Select the cylinders at the balance switch (9) in their firing order, and press the Balance knob (10) to short-circuit them in turn. **The drop in engine speed should be the same for all cylinders.** Check compression if there are excessive variations in speed. See page 11-00/12.

Here cylinder 4 is short circuited with the balance push button switch.

¹⁾ on 2002 TI

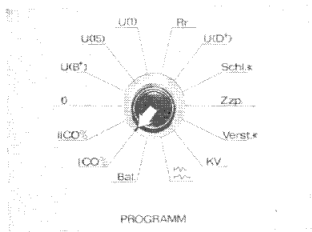

Switch position I CO %
CO measurement at idle speed¹⁾

CO content of exhaust (vol. %) – adjusting idle speed

Conditions for CO measurement:

1. Engine at normal operating temperature. Oil temperature at least 60° C (140° F).
2. Carburetors must be correctly synchronized on 2002 TI.
3. Automatic choke mechanism disconnected.
4. No leaks in exhaust system.
5. Selector lever of automatic transmission must be in neutral.
6. Air cleaner elements must be in good condition. Check and replace if necessary.
7. Exhaust emission tester must be warmed up and zeroed.

Warning: For measurements on roller dynamometer, use a special probe.

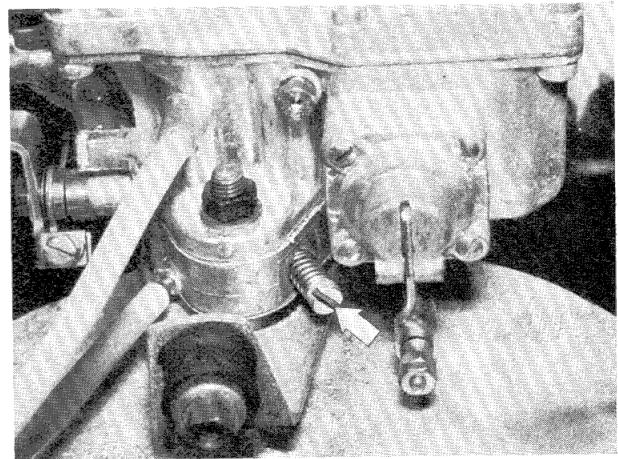
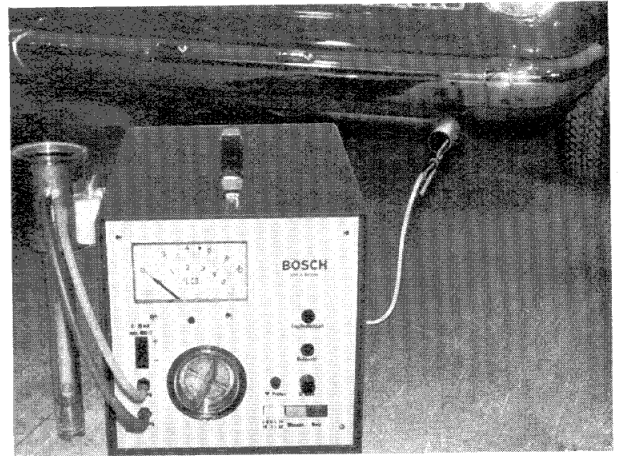

With the air cleaner in position, adjust CO mixture²⁾ with the mixture regulating screws. The engine should run smoothly and evenly.

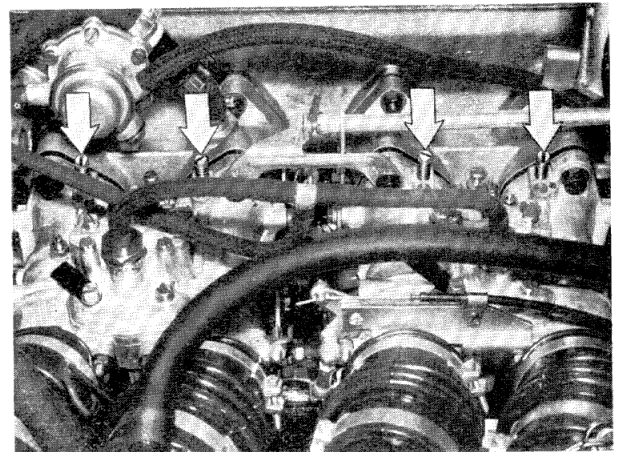

Adjust engine idle speed 13 00 004.

Adjust CO content of exhaust (vol. %)¹⁾ at screw (1).
Engine should continue to run smoothly.
Correct idle speed¹⁾ at screw (2).

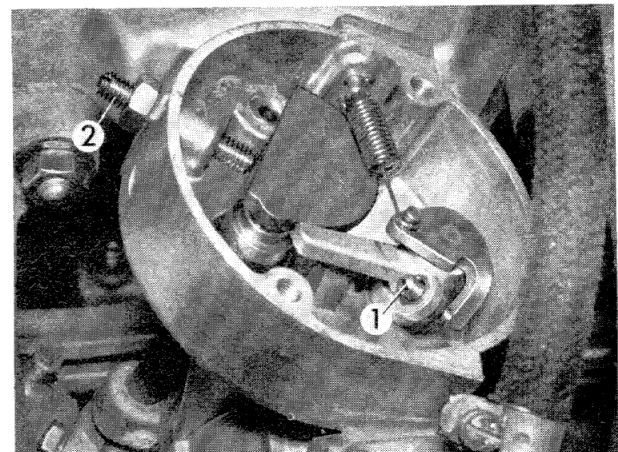

¹⁾ See specifications

²⁾ see Test Values

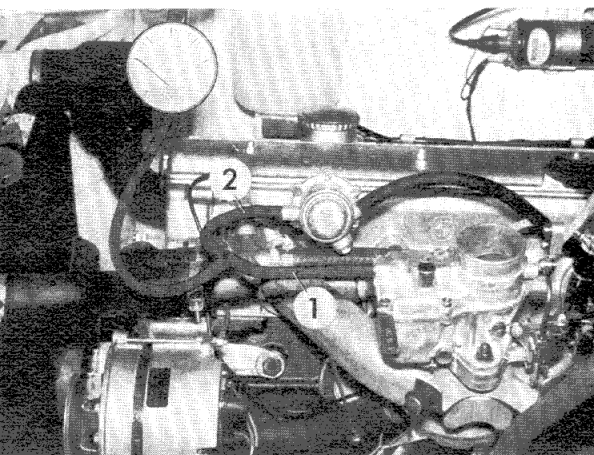

Fuel pump pressure/float needle valves:

Warning:

Always use special test hoses for this check.
The hoses installed on the vehicle must not be kinked.

Turn the changeover tap to position B.
With the engine running, read off the fuel pump pressure¹⁾.

Checking for leakage:

Stop the engine.

If pressure does not fall noticeably, the fuel pump pressure valve and the float needle valve(s) are fueltight.

If pressure falls rapidly:

Start the engine and run until maximum pressure is attained.

Stop the engine.

Kink hose 1 to interrupt flow. If the pressure drops noticeably, the fuel pump pressure valve must be leaking.

Start the engine again and run up to maximum pressure.

Stop the engine.

Kink hose 2. If pressure drops noticeably, the float needle valve is leaking.

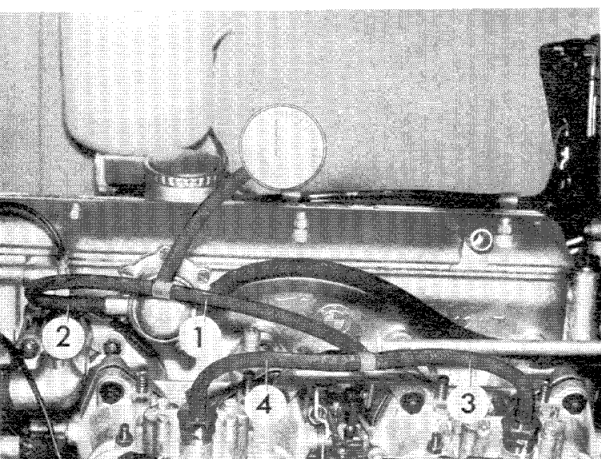

With twin carburetors:

Kink hoses 2 and 3. If the pressure drops noticeably, the float needle valve of the front carburettor is leaking.

Start the engine again and run up to maximum pressure.

Stop the engine.

Kink hoses 2 and 4. If pressure drops noticeably, the float needle valve of the rear carburettor is leaking.



¹⁾ see Test Values

Additional test

Voltage, resistance and capacitance measurements can also be made through the range switch with the test lead. These measurements can be made in any program switch position, without discontinuing the remainder of the program. Only the voltmeter is disconnected.

Voltage measurement

Depending on the measuring range needed, set the range switch to $\times 1\text{ V}$ or $\times 0.1\text{ V}$.

Connect test lead with red clip to +
black clip to -

Measuring capacitance

Depending on the measuring range needed, set the range switch to $\times 1\ \mu\text{F}$ or $\times 0.1\ \mu\text{F}$.

Warning: When measuring capacitance the test lead terminals must not be short-circuited or subjected to a voltage.

Disconnect built-in condensers before making the test. Place the condenser between the clips of the test lead. Read off the test value¹⁾ on the meter.

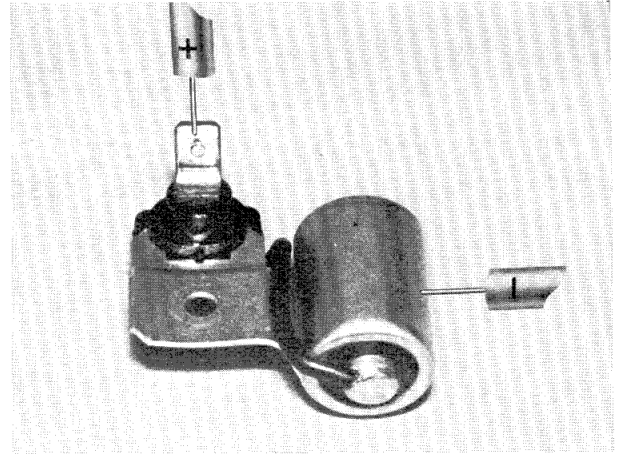

Note: Condensers which have been out of use for a long period, and also new condensers, must be charged and discharged once before measurement. If this is not done, the series resistance shown will be too large, although this will disappear as soon as the condenser is in regular service.

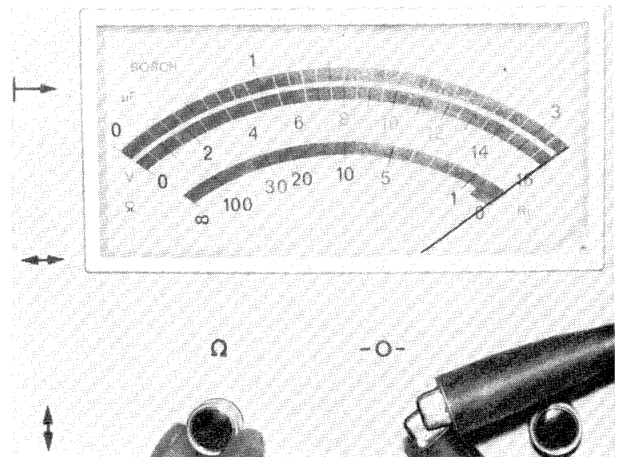

Measuring resistance

Depending on the measured value, set the range switch to $\times 1\ \Omega$ or $\times 1\ \text{K}\Omega$.

Before each measurement, zero the range in use.

Short circuit the test lead terminals.

With the Ω knob, set the meter needle to 0 (lower scale).

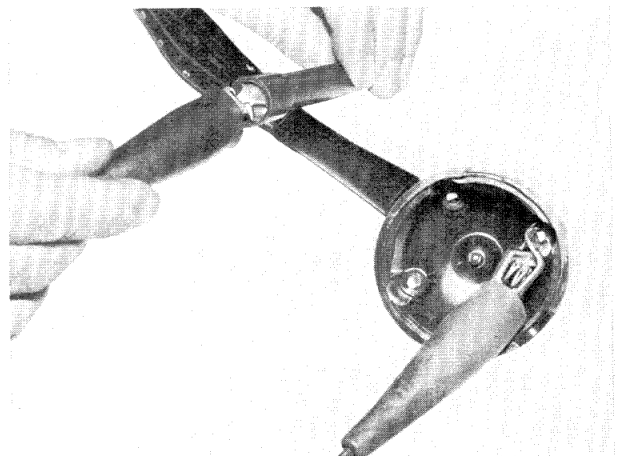

Place the resistor¹⁾ between the clips of the test lead and read off the resistance value.

The higher the insulation resistance, the better the insulator. If the insulation is in good condition, the meter will (if set to range $\times 1\ \text{K}\Omega$) be fully deflected, thus indicating an infinite resistance value.

Warning: Do not apply a voltage to the test terminals. A fuse of 0.25 Amp rating will be found on the front panel of the tester at the right.

¹⁾ See specifications
9.75 Alteration

Test data – BMW 1502

Switch position	Item tested	Desired value	
U (B +)	Battery voltage without current consumers	min. 11.8 V	
U (15)	Voltage at coil terminal 15 a) with coil off load current	min. 10.8 V	
	b) when starting engine	min. 9.0 V	
U (1)	Voltage drop at contact breaker and push-fit terminals	max. 0.3 V	
Rr	Condenser – series resistance	within Rr range	
U (D+)	Alternator: a) Voltage at D +	13.5...14.6 V	
	b) Test with oscilloscope at 900 rev/min	see page 11-00/5	
Schl. †	Dwell angle Contact breaker gap	59...65° min. 0.35 mm (0.0138 in)	
	Cam displacement at 2000 rev/min (on oscilloscope)	max. 3°	
Zzp.	Ignition point at 1900 rev/min (engine at normal operating temperature)	25° BTDC	
Verst. †	Centrifugal advance (engine at operating temperature) Direct stroboscopic beam at TDC mark Ignition distributor No. 0 231 188 001	rev/min	°CS BTDC
		1000	5...10
		1500	16...20
		2000	26...30
		2500	32...37
		3000	34...38
		3500	37...41
4000	38...45 (ends)		
	Centrifugal advance	Begins app. 800 rev/min Ends app. 4000 rev/min	
KV	Ignition voltage at 1200...1400 rev/min	6...11 KV	
	Voltage variation between cylinders	2...3 KV	
	Increase on accelerating	max. 3 KV	
	Ignition coil idling voltage (plug cap disconnected from spark plug)	min. 18 KV	
Bal.	Comparison of cylinder output at 1000 rev/min	speed drop should be equal as far as possible	
ICO%	Exhaust emission test at 850...950 rev/min	2.0...3.0 Vol. % CO	
	Fuel pump pressure	0.21...0.30 kp/cm ² (2.99...4.27 lb/in ²)	

Test data BMW 1600/2

U (B +)	Battery voltage without current consumers	min. 6.1 V	
U (15)	Voltage at coil terminal 15 a) with coil off load current	min. 5.5 V	
	b) when starting engine	min. 4.5 V	
U (1)	Voltage drop at contact breaker and push-fit terminals	max. 0.2 V	
Rr	Condenser - series resistance	within Rr range	
Schl. ⚡	Dwell angle Contact breaker gap	61 ÷ 66° min. 0.35 mm (0.0138")	
	Cam displacement at 2000 rpm (on oscilloscope)	max. 3°	
Zzp.	Ignition point at 1400 rpm, engine at normal operating temperature, with vacuum advance inoperative	25° BTDC	
Verst. ⚡	Centrifugal advance (without vacuum advance, engine at operating temperature)	rpm	°CS BTDC
		1000	23 ÷ 27
	Direct stroboscopic beam to TDC mark	1500	25 ÷ 29
		2000	30 ÷ 34
		2500	34 ÷ 38
		3000	38 ÷ 42
		3500	40 ÷ 44
Ignition distributor No. 0231 115 048 0231 115 072	3800	42 ÷ 46 (end)	
Vacuum advance	Begin 120 ÷ 150 mm Hg (4.72 ÷ 5.91 in. merc.)		
	End 195 ÷ 210 mm Hg (7.68 ÷ 8.27 in. merc.)		
	Advance range	8 ÷ 12° CS	
KV	Ignition voltage at 1200 ÷ 1400 rpm	6 ÷ 11 KV	
	Voltage variation between cylinders	2 ÷ 3 KV	
	Increase when accelerating	max. 3 KV	
	Ignition coil idling voltage (plug cap disconnected from spark plug)	min. 16 KV	
Bal.	Comparison of cylinder output at 1000 rpm	speed drop should be equal as far as possible	
ICO %	Exhaust emission test at 700 ÷ 800 rpm	max. 4.5 Vol % CO	
	Fuel pump pressure	0.21 ÷ 0.25 kp/cm ² (2.99 ÷ 3.56 psi)	

1) Direct stroboscopic beam to TDC notch in belt pulley – timing advance tester set to 25°.

Test data BMW 1602/1/02

U (B +)	Battery voltage without current consumers	min. 12.2 V	
U (15)	Voltage at coil terminal 15 a) with coil off load	min. 11.0 V	
	b) when starting engine	min. 9.0 V	
U (1)	Voltage drop at contact breaker and push-fit terminals	max. 0.3 V	
Rr	Condenser – series resistance	within Rr range	
U (D +)	Alternator: a) Voltage at D positive	13.5 ÷ 14.6 V	
	b) Test with oscilloscope at 900 rpm	see page 11-00/6	
Schl. K	Dwell angle Contact breaker gap	61 ÷ 65° min. 0.35 mm (0.0138")	
	Cam displacement at 2000 rpm (on oscilloscope)	max. 3°	
Zzp.	Ignition point at 1400 rpm, engine at normal operating temperature, with vacuum advance inoperative	25° BTDC ¹⁾	
Verst. K	Centrifugal advance (without vacuum advance, engine at operating temperature). Direct stroboscopic beam to TDC mark Ignition distributor No. 0231 115 048 0231 115 072 0231. 180 004 with rev. governor	rpm	°CS BTDC
		1000	23 ÷ 27
		1500	25 ÷ 29
		2000	30 ÷ 34
		2500	34 ÷ 38
		3000	38 ÷ 42
		3500	40 ÷ 44
3800	42 ÷ 46 (end)		
	Vacuum advance	Begin 120 ÷ 150 mm Hg (4.72 ÷ 5.91 in. merc.)	
		End 195 ÷ 210 mm Hg (7.68 ÷ 8.27 in. merc.)	
		Advance range 8 ÷ 12° CS	
KV	Ignition voltage at 1200 ÷ 1400 rpm	6 ÷ 11 KV	
	Voltage variation between cylinders	2 ÷ 3 KV	
	Increase when accelerating	max. 3 KV	
	Ignition coil idling voltage (plug cap disconnected from spark plug)	min. 16 KV	
Bal.	Comparison of cylinder output at 1000 rpm	speed drop should be equal as far as possible	
ICO %	Exhaust emission test at 700 ÷ 800 rpm	max. 4.5 Vol % CO	
	Fuel pump pressure	0.21 ÷ 0.25 kp/cm ² (2.99 ÷ 3.56 psi)	

1) Direct stroboscopic beam to TDC notch in belt pulley or to ball mark in flywheel and set timing advance tester to 25°.

Test data BMW 2002 TI

Switch position	Item tested	Desired value	
J (B+)	Battery voltage without current consumers	min. 11.8 V	
J (15)	Voltage at coil terminal 15 a) with coil off load current	min. 10.8 V	
	b) when starting engine	min. 9.0 V	
J (1)	Voltage drop at contact breaker and push-fit terminals	max. 0.3 V	
Rr	Condenser-series resistance	within Rr range	
J (D+)	Alternator: a) Voltage at D+	13.5 ... 14.6 V	
	b) Test with oscilloscope at 900 rev/min	see page 11-00/6	
Schl. ✱	Dwell angle Contact breaker gap	59 ... 65° min. 0.35 mm (0.0138 in)	
	Cam displacement at 2000 rev/min (on oscilloscope)	max. 3°	
Zzp.	Ignition point at 2200 rev/min (engine at normal operating temperature)	25° BTDC ¹⁾	
Verst. ✱	Centrifugal advance (engine at operating temperature) Direct stroboscopic beam at TDC mark Ignition distributor No. 0 231 129 037 0 231 151 003 with engine speed governor 0 231 129 033 ²⁾	rev/min	°CS BTDC
		1000	3 ... 8 10 ... 13 ²⁾
		1500	14 ... 19 17 ... 21 ²⁾
		2000	20 ... 24 22 ... 26 ²⁾
		2500	25 ... 29 26 ... 30 ²⁾
		3000	30 ... 34 29 ... 33 ²⁾
	3500	32 ... 36(end) 33 ... 37 (end) ²⁾	
KV	Ignition voltage at 1200 ... 1400 rev/min	6 ... 11 KV	
	Voltage variation between cylinders	2 ... 3 KV	
	Increase on accelerating	max. 3 KV	
	Ignition coil idling voltage (plug cap disconnected from spark plug)	min. 18 KV	
V	Comparison of cylinder output at 1000 rev/min	speed drop should be equal as far as possible	
ICO %	Exhaust emission test at 700 ... 900 rev/min	max. 4.5 Vol. %CO	
	Fuel pump pressure	0.21 ... 0.30 kp/cm ² (2.99 ... 4.27 lb/in ²)	

1) Direct stroboscopic beam at TDC notch in belt pulley or to ball mark in flywheel and set timing advance tester to 25°.

2)

Test data BMW 2002 tii

Switch position	Item tested	Desired value	
U (B+)	Battery voltage without current consumers	min. 11.8 V	
U (15)	Voltage at coil terminal 15 a) with coil off load current	min. 10.8 V	
	b) when starting engine	min. 9.0 V	
U (1)	Voltage drop at contact breaker and push-fit terminals	max. 0.3 V	
Rr	Condenser-series resistance	within Rr range	
U (D+)	Alternator: a) Voltage at D+	13.5 ... 14.6 V	
	b) Test with oscilloscope at 900 rev/min	see page 11-00/6	
Schl. ✕	Dwell angle Contact breaker gap	59 ... 65° min. 0.35 mm (0.0138 in)	
	Cam displacement at 2000 rev/min on oscilloscope	max. 3°	
Zzp.	Ignition point at 2800 rpm ³⁾ , engine at normal operating temperature	25° BTDC ¹⁾	
Verst. ✕	Centrifugal advance (engine at operating temperature)	rev/min	°CS BTDC
		1000	2 ... 7
	Direct stroboscopic beam at TDC mark	1500	12 ... 17
		2000	18 ... 22
	Ignition distributor No. 0 231 151 003	2500	24 ... 28
		3000	28 ... 32
0 231 151 008 with rev governor	3500	30 ... 34 (end)	
KV	Ignition voltage at 1200 ... 1400 rev/min	6 ... 11 KV	
	Voltage variation between cylinders	2 ... 3 KV	
	Increase on accelerating	max. 3 KV	
	Ignition coil idling voltage (plug cap disconnected from spark plug)	min. 18 KV	
Bal.	Comparison of cylinder output at 1000 rev/min	speed drop should be equal as far as possible	
ICO%	Exhaust emission test at 900 + 50 rev/min	max. 4.5 Vol. % CO	
	Fuel pump pressure	1.5 ... 2.5 kp/cm ² 2) (2.13 ... 3.55 lb/in ²)	

1) Direct stroboscopic beam at TDC notch in belt pulley or to ball mark in flywheel and set timing advance tester to 25°.

2) Oil return line from injection pump to crankcase.

3) With 9.5:1 compression ratio; identification: cast intake pipes

2900 rev/min with 10:1 compression ratio; identification: plastic ram air pipes

Test data BMW 2002/2002 A – USA

Switch position	Item tested	Desired value	
(B+)	Battery voltage without current consumers	min. 12.2 V	
(15)	Voltage at coil terminal 15 a) With coil off load current	min. 11.0 V	
	b) When starting engine	min. 9.0 V	
(1)	Voltage drop at contact breaker and push-fit terminals	max. 0.3 V	
R	Condenser-series resistance	within Rr range	
D+	Alternator: a) Voltage at D positive	13.5 ... 14.6 V	
	b) Test with oscilloscope at 900 rev/min	see page 11-00/6	
chl. K	Dwell angle Contact breaker gap	59 ... 65° min. 0.35 mm (0.0138 in)	
	Cam displacement at 2000 rev/min (on oscilloscope)	max. 3°	
Zp.	Ignition point at 2000 rev/min ²⁾ ; engine at normal operating temperature, with vacuum advance inoperative	25° BTDC ¹⁾	
Verst. K	Centrifugal advance (without vacuum advance, engine at operating temperature) Direct stroboscopic beam at TDC mark Ignition distributor No. 0 231 115 081 0 231 180 003 with rev governor	rev/min	°CS BTDC
		1000	11 ... 15
		1500	17 ... 21
		2000	23 ... 27
		2500	30 ... 33
		3000	37 ... 41
		3500	41 ... 45
		3800	42 ... 46 (end)
	Vacuum advance	Begin	120 ... 150 mm Hg (4.72 ... 5.91 in mercury)
		End	195 ... 210 mm Hg (7.68 ... 8.27 in mercury)
		Advance range	8 ... 12°CS
KV	Ignition voltage at 1200 ... 1400 rev/min	6 ... 11 KV	
	Voltage variation between cylinders	2 ... 3 KV	
	Increase on accelerating	max. 3 KV	
	Ignition coil idling voltage (plug cap disconnected from spark plug)	min. 18 KV	
Bal.	Comparison of cylinder output at 1000 rev /min	speed drop should be equal as far as possible	
ICO %	Exhaust emission test at 700 ... 900 rev/min	1 ... 1.2 Vol. % CO	
	Fuel pump pressure	0.21 ... 0.30 kp/cm ² (2.99 ... 4.27 lb/in ²)	

1) Direct stroboscopic beam at TDC notch in belt pulley or to ball mark in flywheel and set timing advance tester to 25°.
2) 1500 rev/min without air pump

Test data for additional test

Battery charge	Acid specific gravity	Off load voltage	Battery voltage without current consuming equipment
Full	1.28	2.12 – 2.13	12.72 – 12.78 V
Half full	1.20	2.05	12.3 V
Low	1.12	1.97 – 1.98	11.82 – 11.88 V
Voltage at coil terminal 15 or at series resistor input			
a) with coil off load current			min. 11.0 V
b) when starting engine			min. 9.0 V
Voltage drop at contact breaker and push fit terminals			max. 0.3 V
Voltage at alternator D+			13.5 ÷ 14.6 V
Voltage drop B+ to starter motor			max. 0.5 V
B+ to coil 15 or input series resistor			max. 0.4 V
B– to engine block			max. 0.5 V
Suppression resistors ¹⁾			
Distributor rotor			5 K Ω \pm 25 %
Suppressor plugs on distributor cap			1 K Ω \pm 25 %
Plug caps			1 K Ω \pm 25 %
Condenser on distributor ¹⁾			Capacitance
No. 1 237 330 045			0.23 ÷ 0.32 μ F
Capacitance 080			
No. 1 237 330 116			0.15 – 0.20 μ F
Capacitance 124			min. 200 K Ω
Insulation resistance			
Ignition coil ¹⁾			
primary resistance			
Bosch No. 0221 114 010 E 12 V			3.6 ÷ 4.1 K Ω
0221 102 032 K 12 V			3.2 ÷ 3.9 K Ω
0221 119 001 K 12 V			2.9 ÷ 3.4 K Ω
Ignition coil ¹⁾			
with series resistor			
Bosch No. 0221 102 050 KW 12 V			1.7 ÷ 2.1 Ω
Series resistor			
Bosch No. 1224 509 057			0.9 Ω

1) Measured at 20^o C (68^oF)

11 00 050 Engine — removing and fitting

Open bonnet (hood).
Cover wing surfaces with protective aprons.
Pull off breather tube.
Pull hose with connector out of breather tube.
Dismantle air filter.

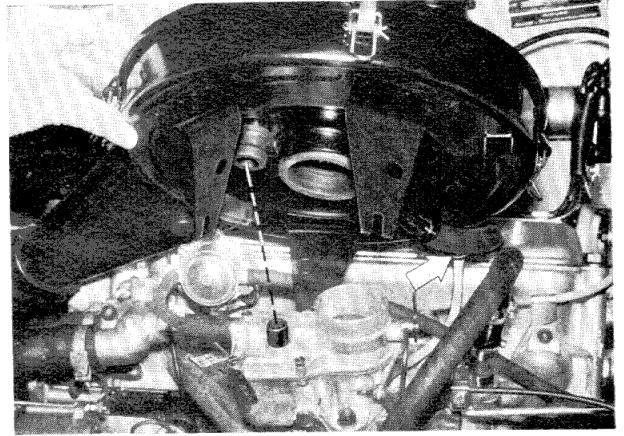

On 2002 T1
Pull off breather tube.
Dismantle air filter.

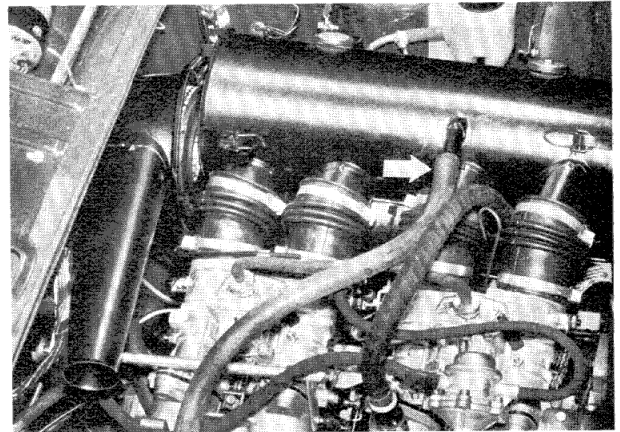

Disconnect earth lead from battery and engine block.
Detach plug from alternator.
Detach cable B + from alternator and starter cable.

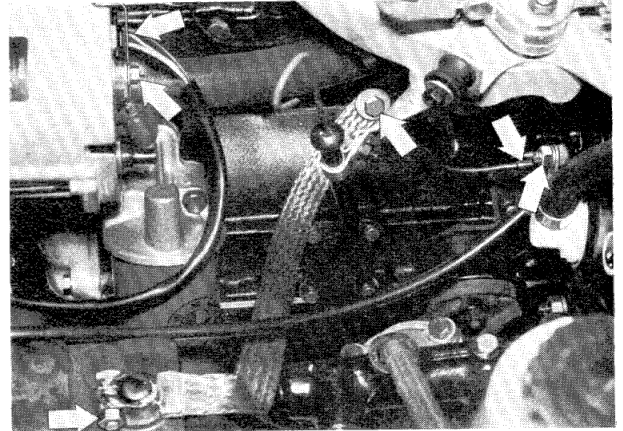

On 2002 A
Pull cable away from automatic choke and thermo-start valve.
Detach plug connection from starter lock.
Pull cable loom out of retainer at gearbox.

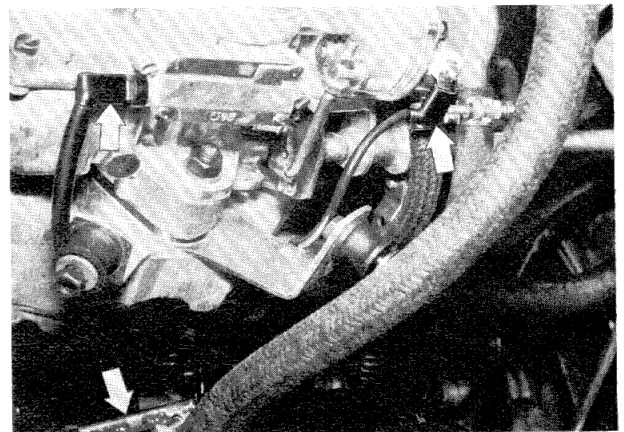

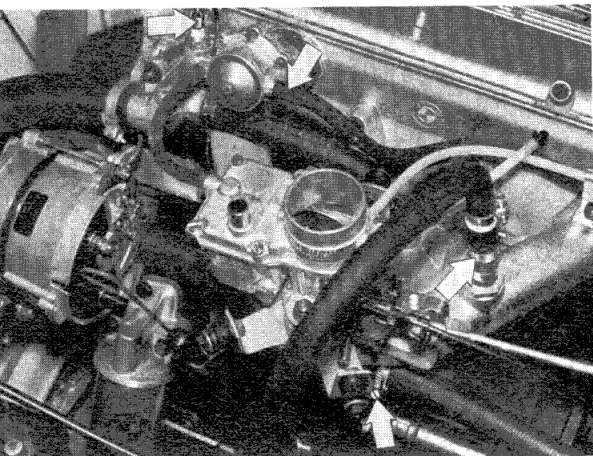

Remove radiator. 17 11 000.
 Pull fuel hose away from fuel pump.
 Pull off cable on remote thermometer sensor contact.
 Dismantle vacuum line with non-return valve from screw union and hot water hose for heater at intake manifold.

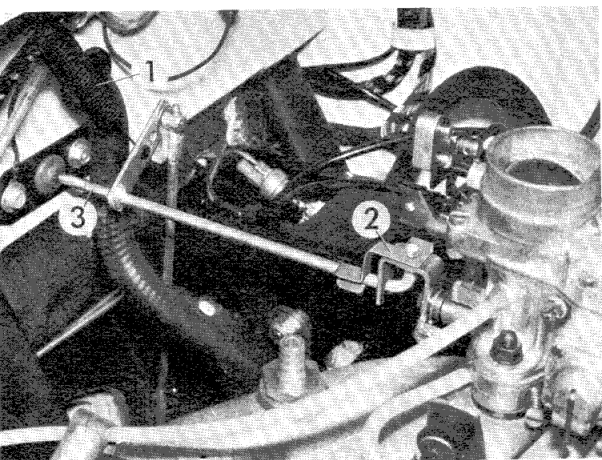

Detach return spring (1) and clamp spring (2).
 Disconnect control rod (3) on carburettor and pull out from support on bulkhead.

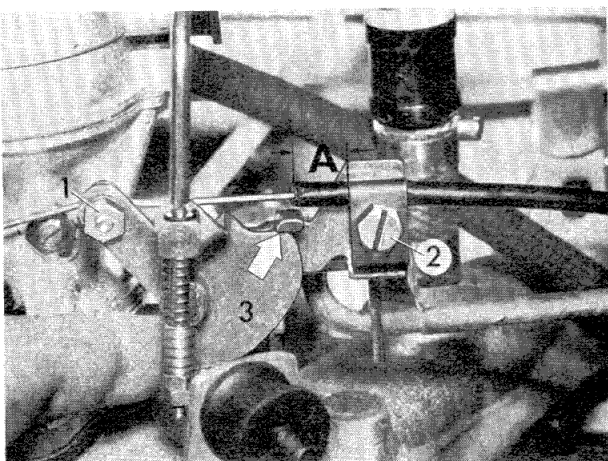

Loosen clamp screw (1) in clamp (2).
 Pull out choke cable.
Fitting instruction: Secure choke cable sleeve.
Warning: Sleeve may project forwards by 15 mm (0.59") max. otherwise the choke flap will not close fully.
 Push choke cable at instrument panel into the bottom notch. Press choke lever (3) against stop. Tighten clamp screw in this position.

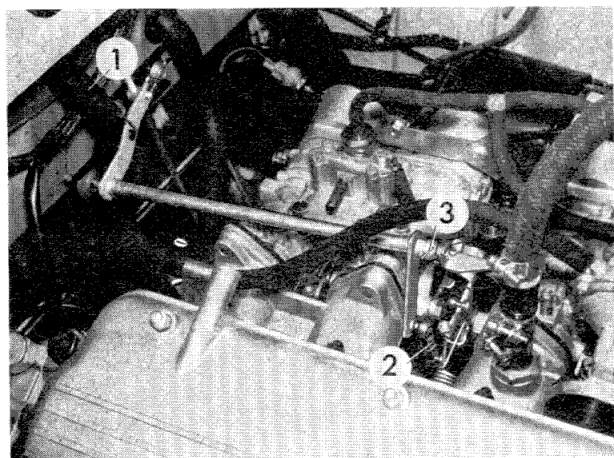

On 2002 TI
 Detach return spring (1) and pull rod (2).
 Lift out retainer (3) from torsion shaft on carburettor.
 Pull back torsion shaft towards bulkhead until ball is free of torsion shaft.
 Pull out torsion shaft forwards.



On 2002 A

Detach clamp spring (1) and return spring (2).

Lift out wire retainer (3).

Pull back torsion shaft towards bulkhead until all is free of torsion shaft.

Pull out torsion shaft forwards.

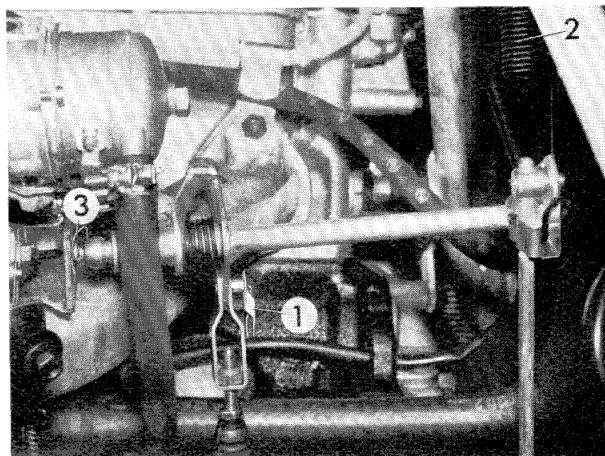

Pull off cable from oil pressure switch and from distributor at terminal 1.

Remove distributor cap, pull out cable 4 and pull off distributor rotor.

Remove hot water hose from cylinder head.

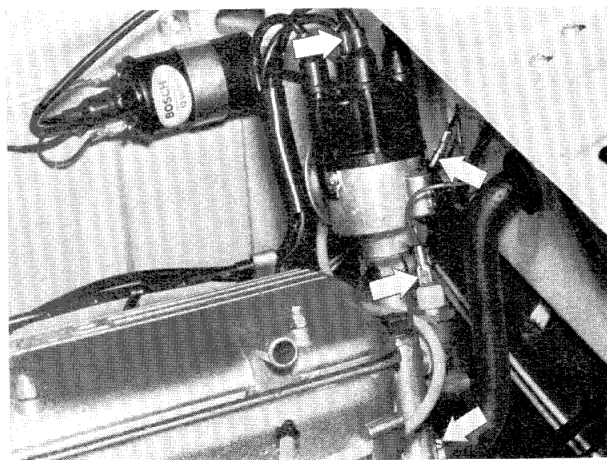

Detach pull rod on intermediate shaft.

Detach bearing support from engine carrier.

Fitting instruction: Align bearing support at 90° to engine.

Pack bearing bushes with Longterm 2.

Breather holes in dust gaiter must face downwards.

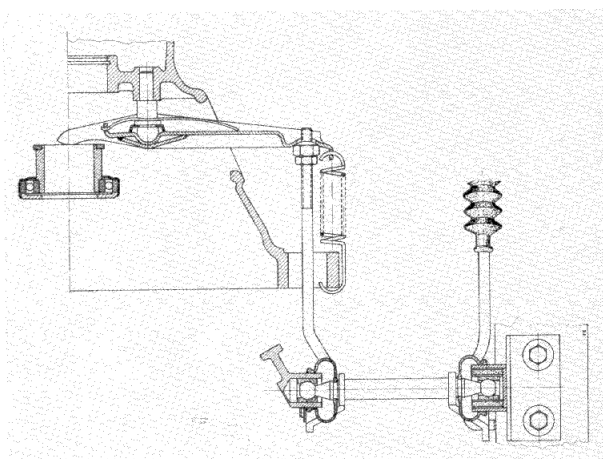

Take out intermediate shaft with push rod.

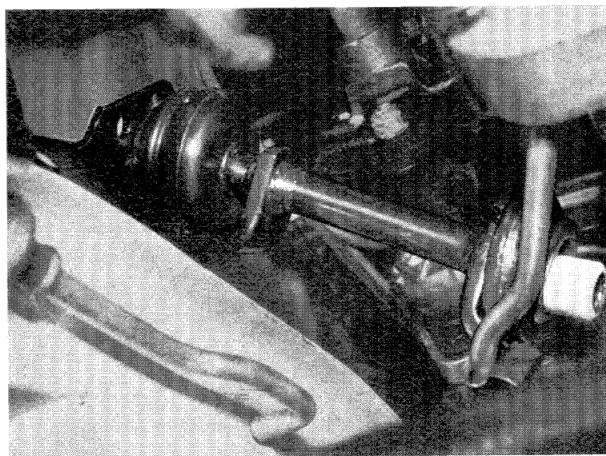

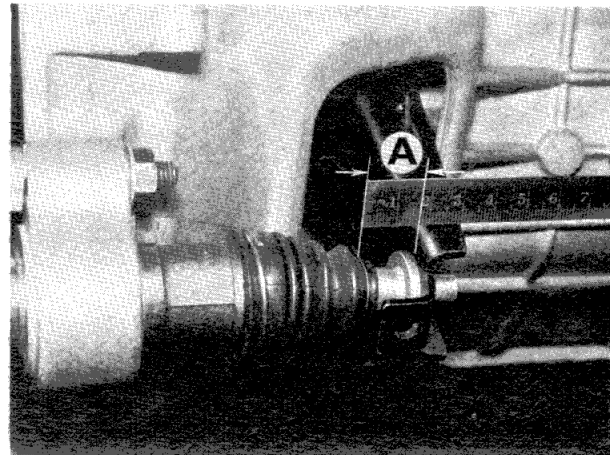

Before dismantling any further:
Check driving disc in situ for wear.
Push release lever in direction of travel up to stop.
In new condition $A = 17 - 19 \text{ mm}$ (0.67 - 0.75")
travel measured at the push rod.
If A is less than 5 mm (0.197"), replace the
driving disc.

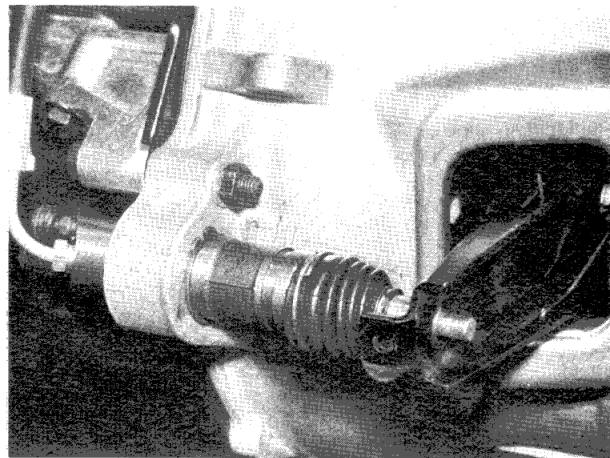

On 2002 and 2002 TI
Pull back collar.
Lift out circlip.
Pull slave cylinder out forwards.
Fitting instruction: Note torsional retainer.

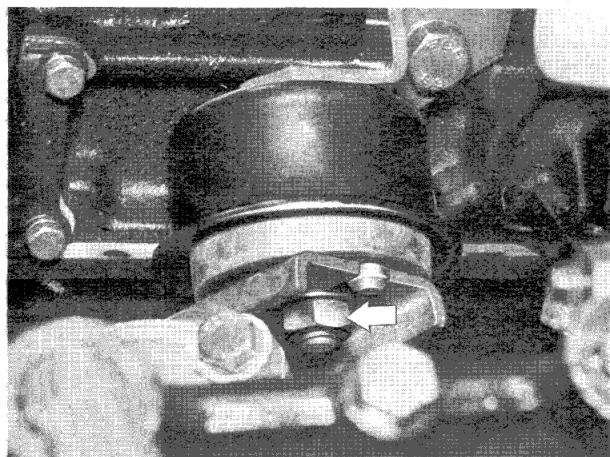

Slacken left-hand rubber bearing.

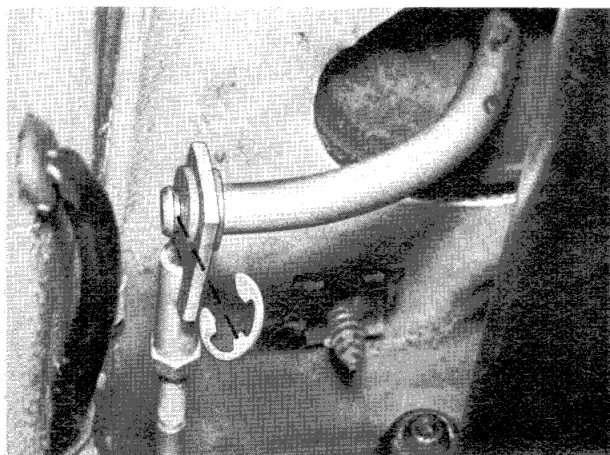

Remove selector lever. 25 11 000.
On 2002 A
Lift out retainer.
Detach selector rod on selector lever.



Remove exhaust support.

Fitting instruction: Secure exhaust pipe to exhaust manifold.

Slacken retaining plate (1), press support (2) tension-free against the exhaust pipe. Secure retaining plate (1) to gearbox and support.

Then tighten bracket (3).

If any other fitting sequence is used severe booming noises can result.

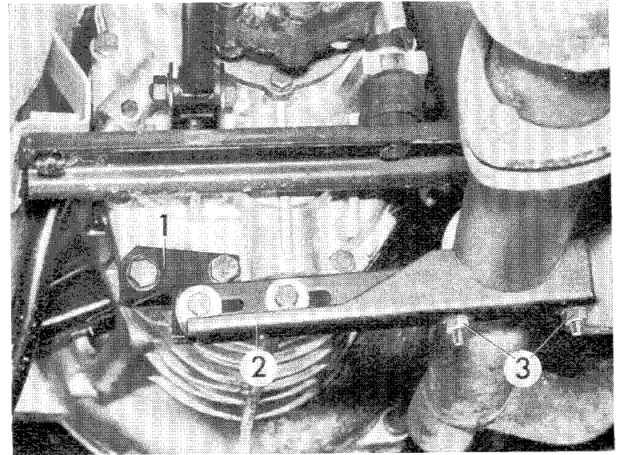

Remove exhaust pipe (4) from exhaust manifold.

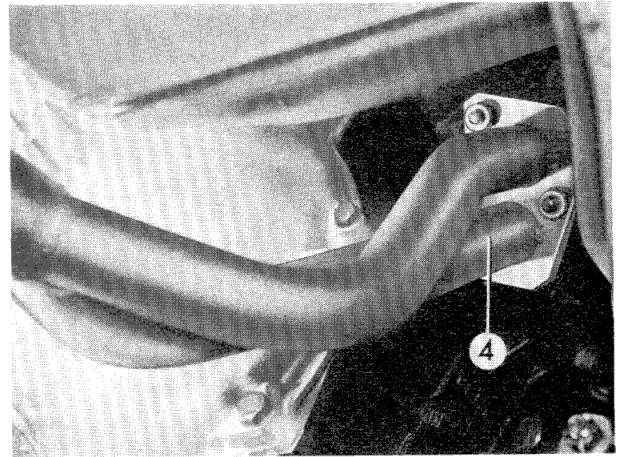

Disconnect propeller shaft at gearbox.

Fitting instruction: In order to avoid stresses in the Giubo coupling only turn the nuts.

Only use lock nuts once.

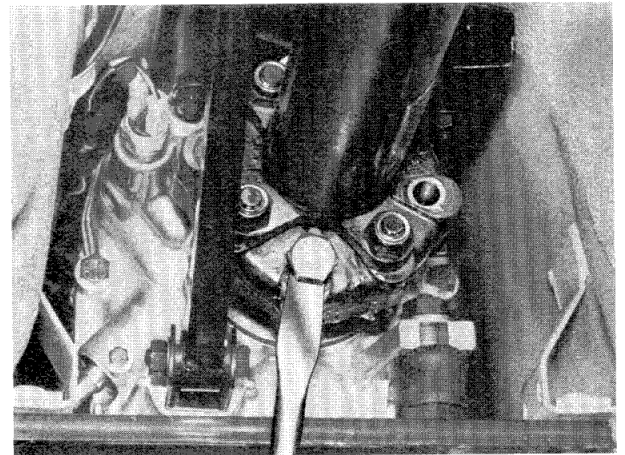

Loosen retaining screws at centre bearing.

Fitting instruction: Pre-load centre bearing forwards by 2 mm (0.08").

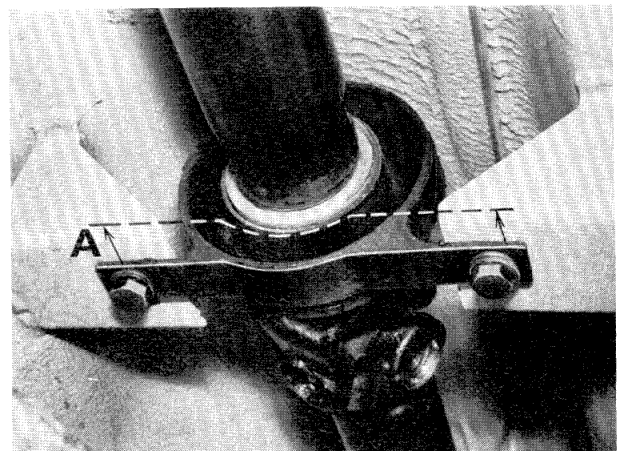

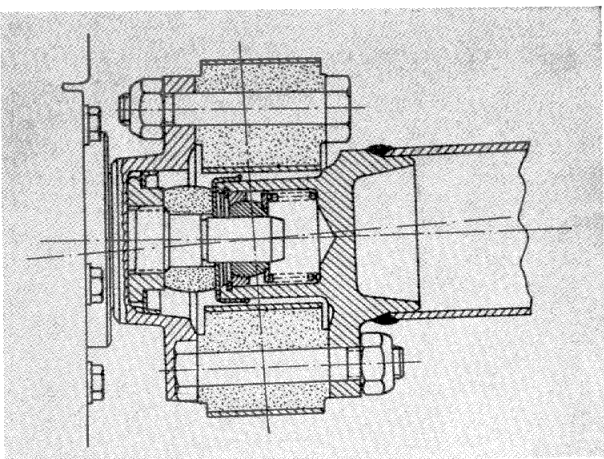

Fitting instruction: Do not damage sealing cap.
Check centering ring for freeness and lubricate with
Longterm 2 if necessary.

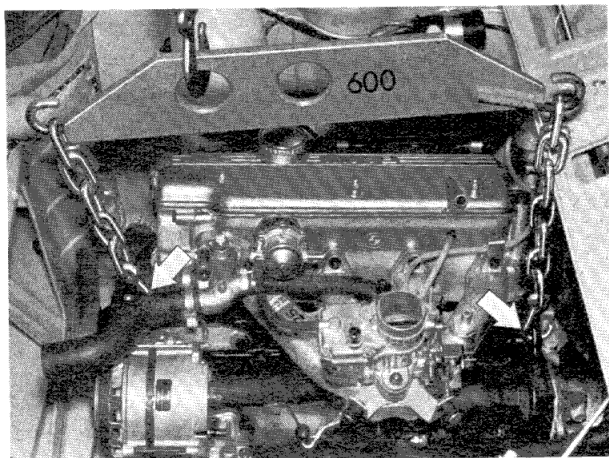

Suspend engine on engine hoist 600.

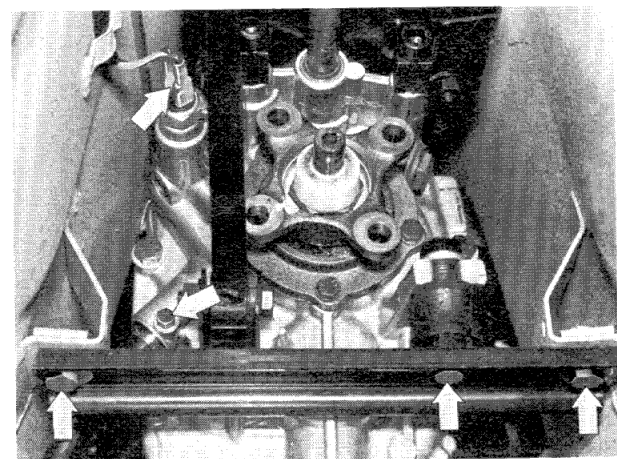

Remove cross member.

Unscrew clamp screw speedometer shaft and pull out
speedometer shaft.

Pull off cable on reversing light switch.

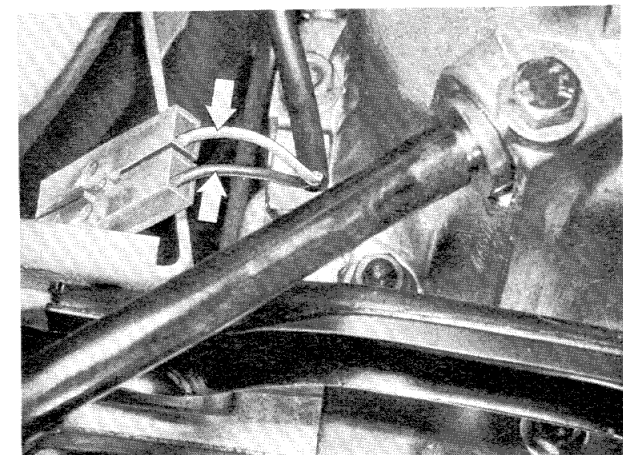

On 2002 A

Detach cable for reversing light from plug connection.



On 2002 A

Pull off cable for starter lock from reversing light/starter lock switch.

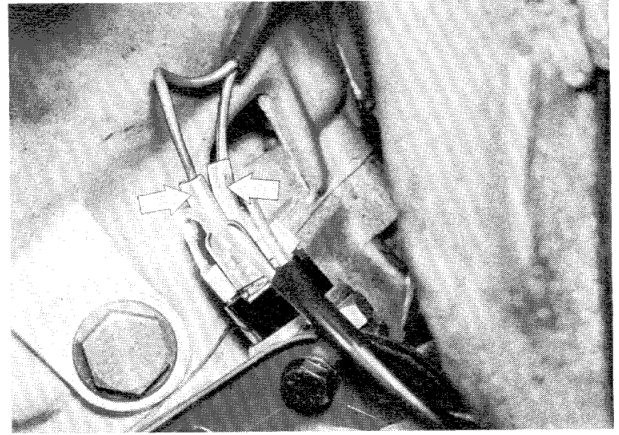

Loosen right-hand engine mounting.

Fitting instruction: Set stop to A = 3 mm (0.118").

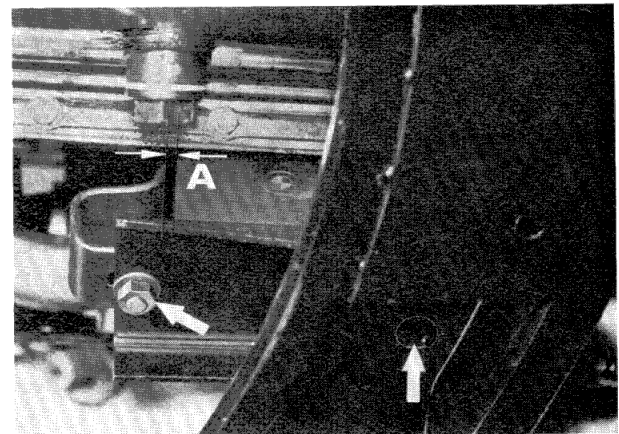

Lift out water reservoir for windshield washer.
Slowly lower gearbox and lift out engine towards the right.

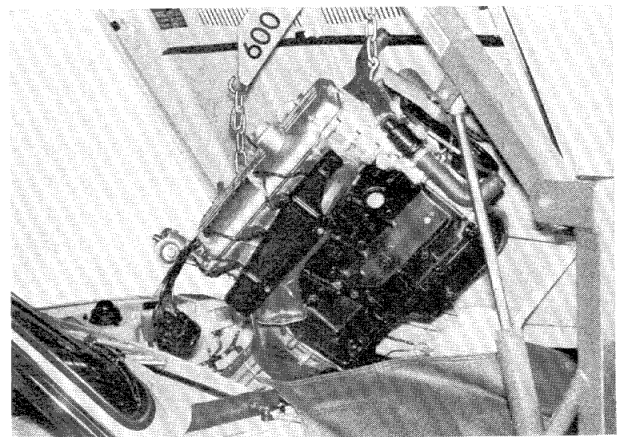

2002 tii

Disconnect negative lead from battery.
Remove gearbox 23 00 020.
Disconnect cable from alternator.
Pull out multiple plug.

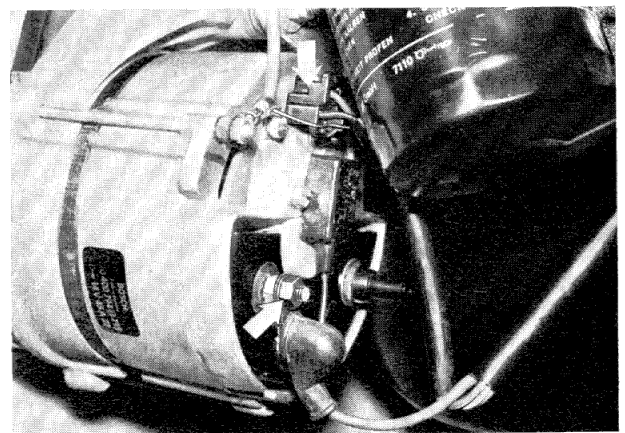

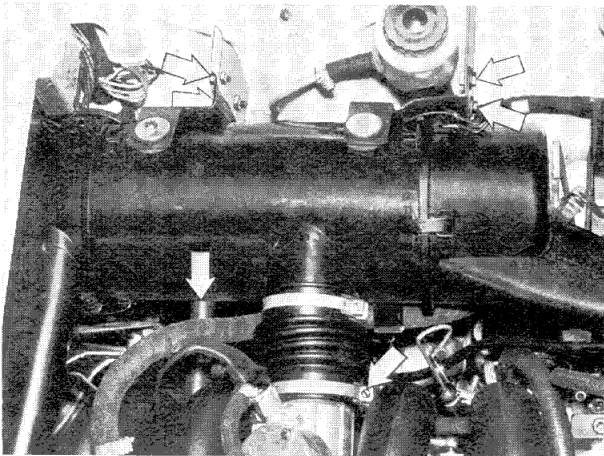

Remove radiator 17 11 000.
Remove air filter.

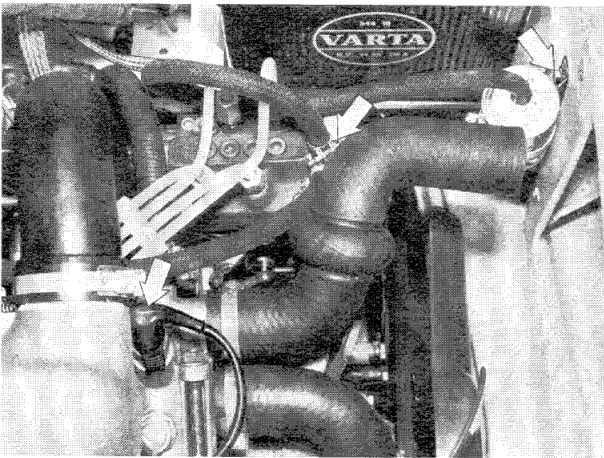

Disconnect negative lead from battery carrier.
Pull off fuel hose from injection pump and
disconnect cable from thermo-time switch.
Detach fuel filter from front panel.

Fitting instructions: Fit fuel hose with clip retainer to
injection pump.

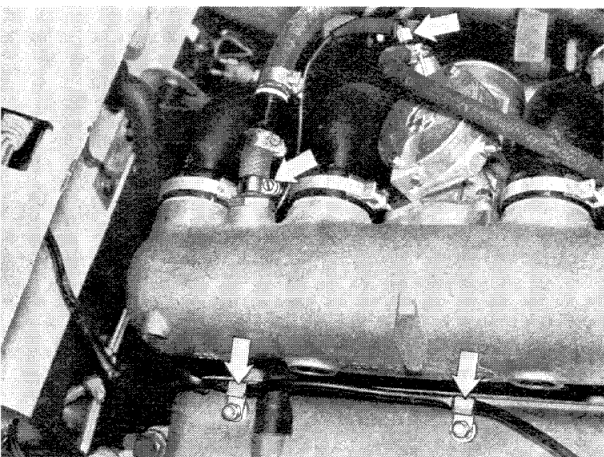

Disconnect vacuum hose from air container and cable
from start valve. Lift out cable from cable camps on
cylinder head cover.

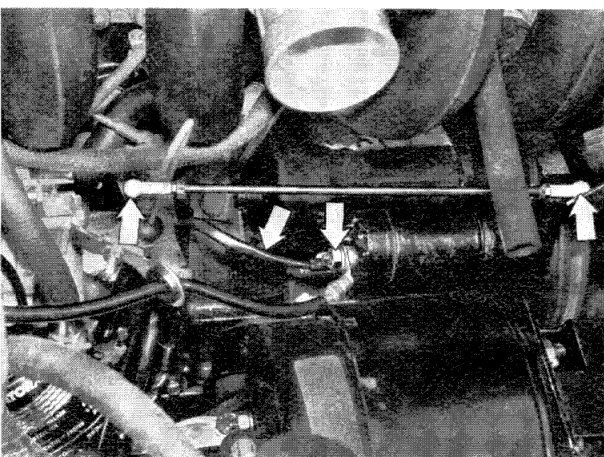

Disconnect accelerator linkage.
Disconnect cable from starter motor and pull out from
retaining ear.



Detach heater hot water hoses from cylinder head and from reflow pipe.
Disconnect fuel reflow hose.

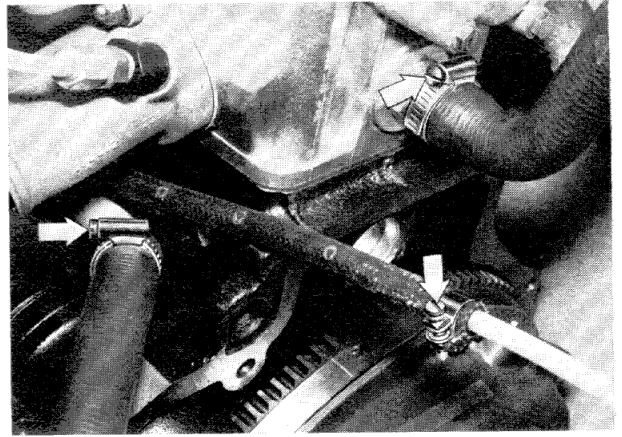

Pull off cables from ignition distributor and from oil pressure switch.
Pull out induction transmitter from ignition coil and remove distributor cap. Pull off distributor rotor.

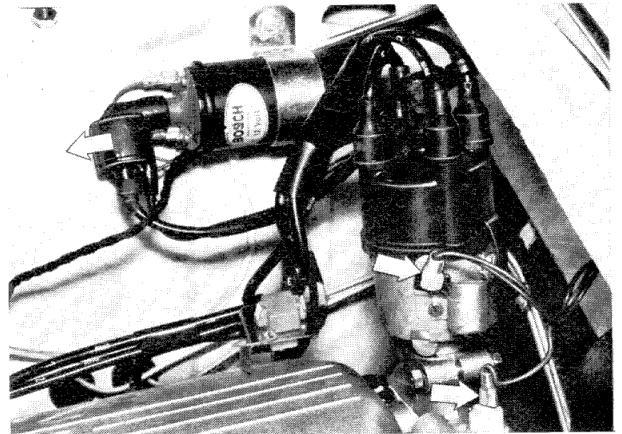

Suspend engine on engine hoist 600.
Lift out water reservoir for windshield washer.

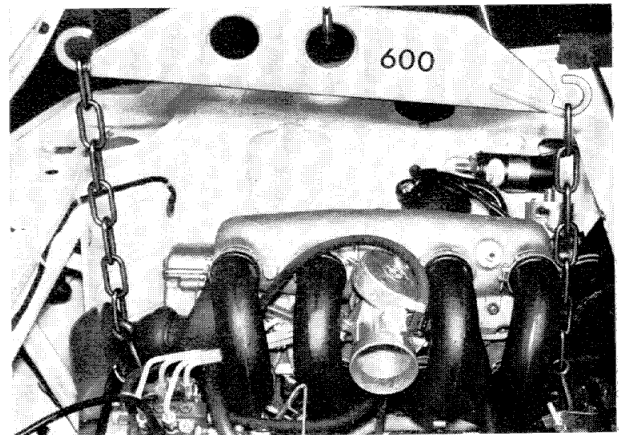

Loosen right-hand engine mounting.

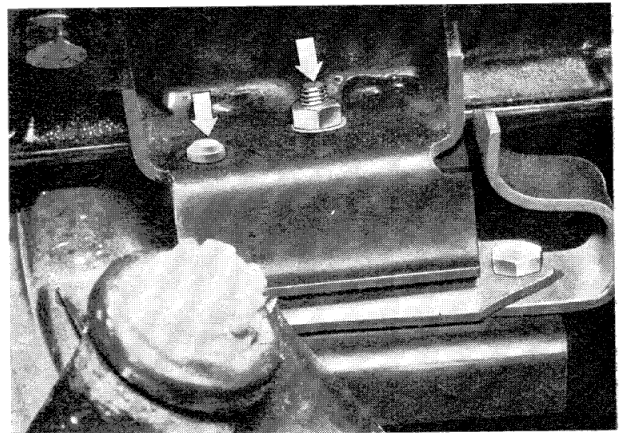

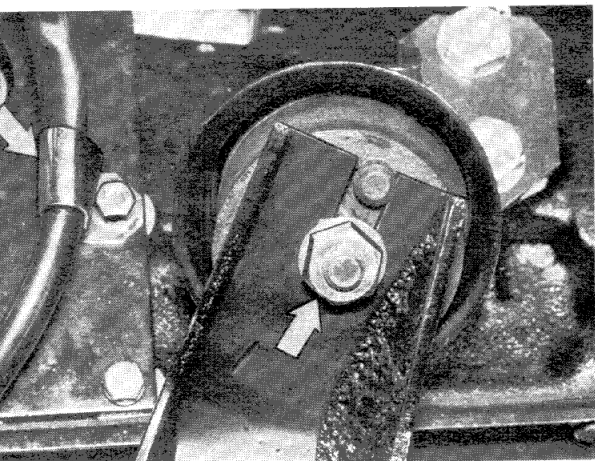

Loosen left-hand engine mounting and loosen cable harness from retaining clamp.

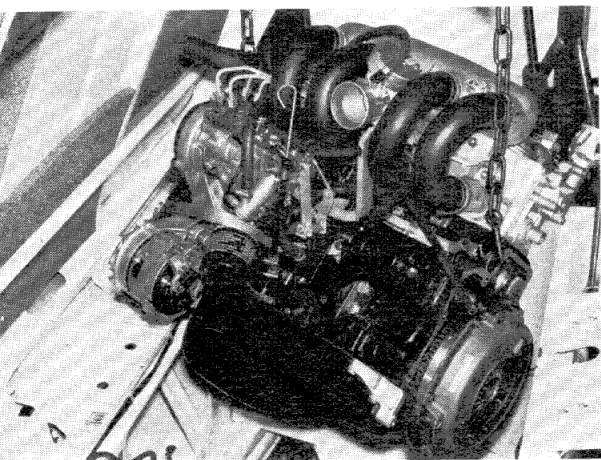

Lift out carefully engine with engine hoist 600.



11 12 000 Cylinder head cover — removing and fitting

Pull off breather tube.

Remove cylinder head cover.

Fitting instruction: Tighten nuts in the sequence 1 - 7.

Secure clips for ignition leads with nuts 1 and 3.

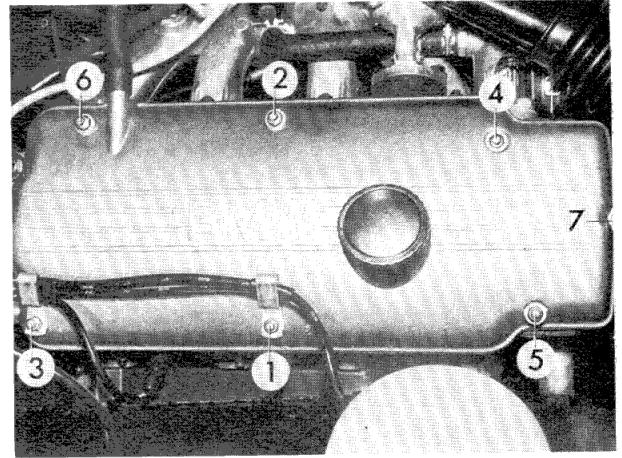

11 12 100 Cylinder head — removing and fitting

Open bonnet (hood).

Cover wing surfaces with protective aprons.

Pull off breather tube.

Pull hose with connector out of breather tube.

Dismantle air filter with distributor body.

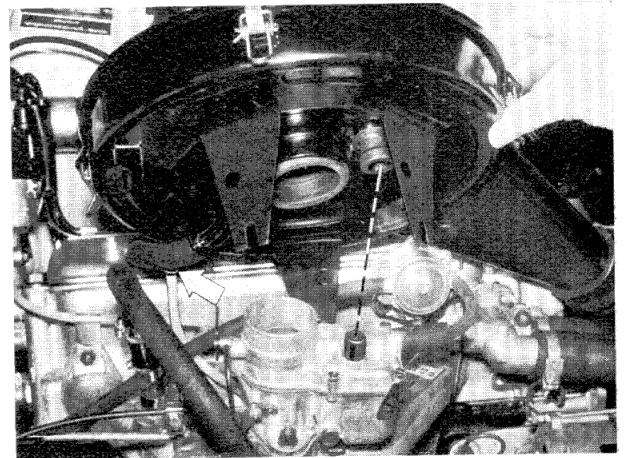

Fitting instruction: Pay attention to freeness of throttle butterfly. Fix throttle butterfly at constant temperatures above + 10° C (50° F).



On 2002 TI

Pull off breather tube.

Remove air filter.

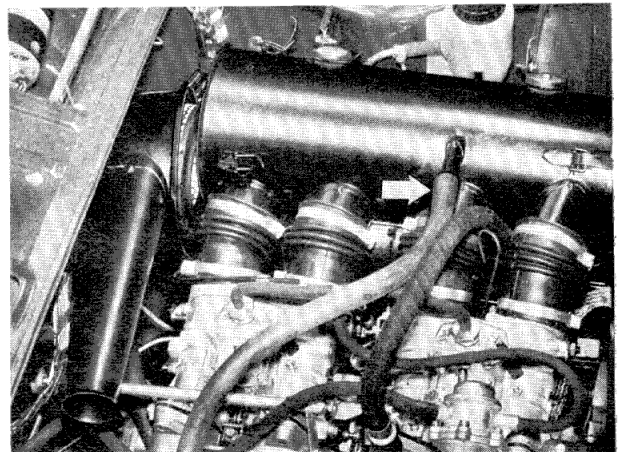

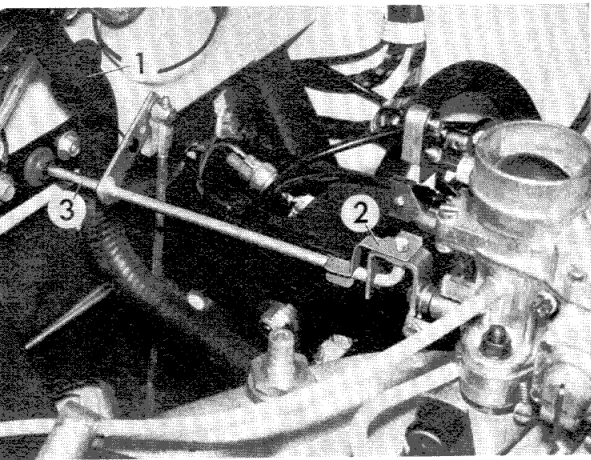

Disconnect earth lead from battery.

Drain off cooling water and collect (antifreeze).

Fitting instruction: Before refilling the cooling system move the heater lever to „warm“. Fill up with water and close radiator cap by turning to stop II. Heat cooling water to 80° C (177° F). After the thermostat has opened bleed the cooling system by turning the radiator cap to stop I. Check the water level and close radiator cap to stop II. Detach return spring (1) and clamp spring (2). Disconnect control rod (3) on carburettor and pull out from support on bulkhead.

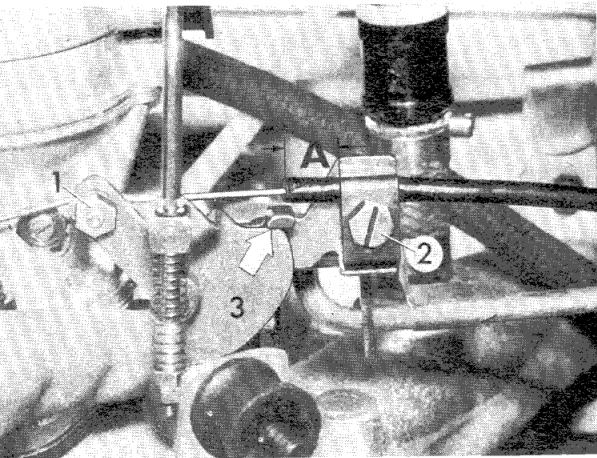

Loosen clamp screw (1) in clamp (2).

Pull out choke cable.

Fitting instruction: Secure choke cable sleeve.

Warning: Sleeve may project forwards by 15 mm (0.59") max. otherwise the choke flap will not close fully.

Push choke cable at instrument panel into the bottom notch. Press choke lever (3) against stop.

Tighten clamp screw in this position.

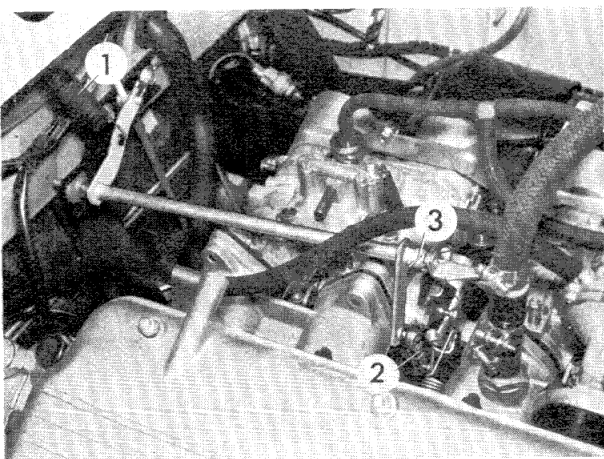

On 2002 TI

Detach return spring (1) and pull rod (2).

Lift out retainer (3) from torsion shaft on carburettor.

Pull back torsion shaft towards bulkhead until ball is free of torsion shaft.

Pull out torsion shaft forwards.

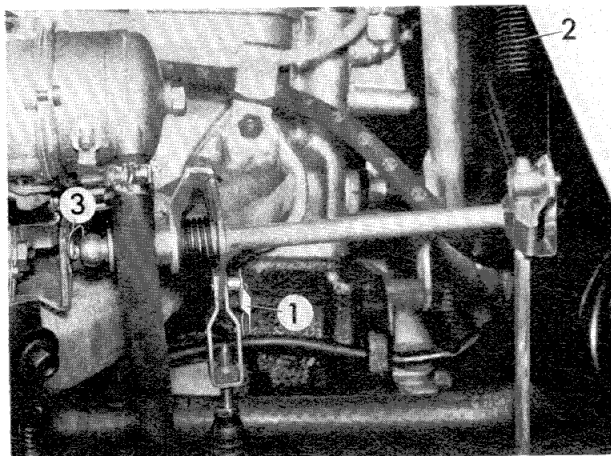

On 2002 A

Detach clamp spring (1) and return spring (2).

Lift wire retainer (3).

Pull back torsion shaft towards bulkhead until ball is free of torsion shaft.

Pull out torsion shaft forwards.



Remove vacuum hose with check valve from threaded manifold and detach warm water hoses¹⁾ from intake manifold. Remove oil dipstick holder.

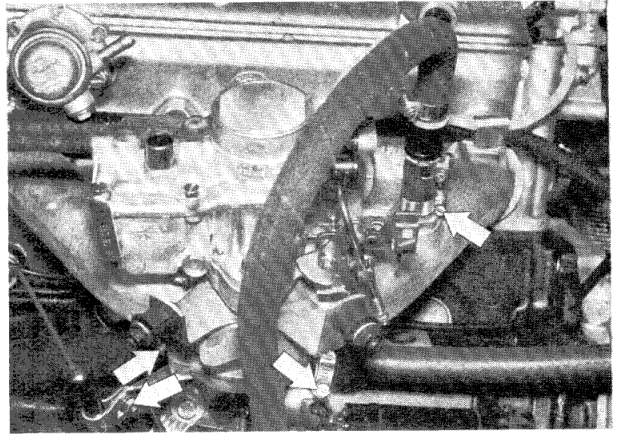

Pull fuel hose off fuel pump and cable off remote thermometer switch. Remove water hoses from branch stub.

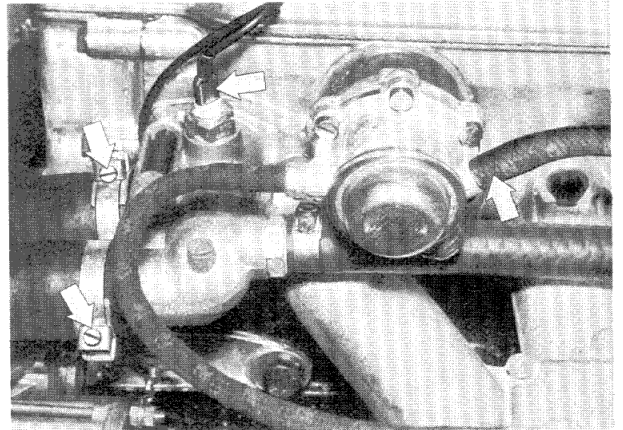

Pull cable off oil pressure switch and terminal 1 of distributor. Remove distributor cap. Pull cable 4 out of coil and detach ignition leads. Detach warm water hose from cylinder head.

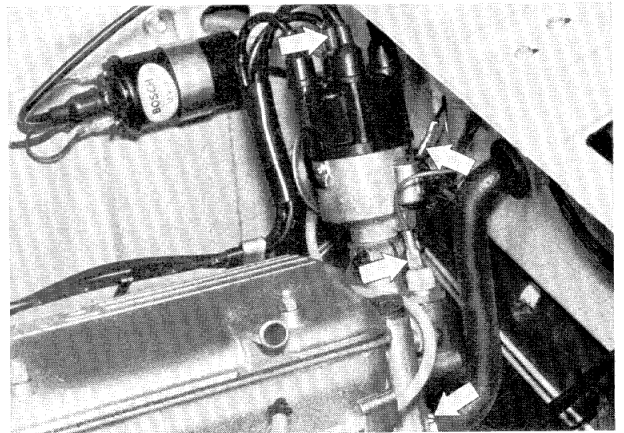

Removal of upper timing case cover – 11 14 100.
Move cylinder in piston 1 to TDC.
The distributor rotor must point at the notch in the distributor housing.
The indicator must point at the second notch on the belt pulley when turning clockwise.

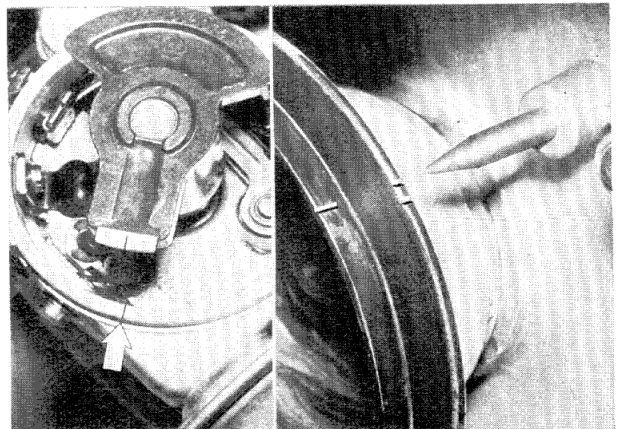

¹⁾ except 2002 TI
9. 75 Alteration

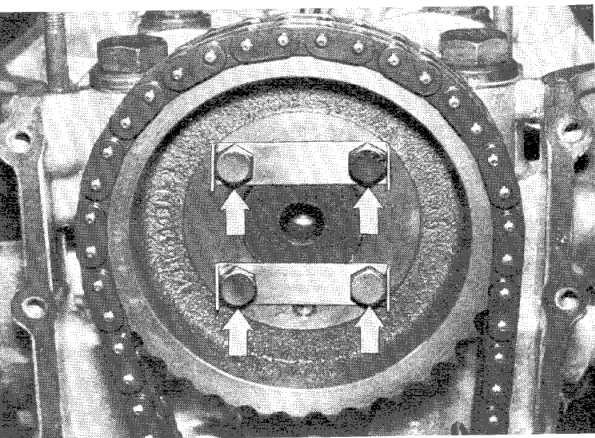

Removal of chain tightener piston – 11 31 090.
Open keeper plates.
Remove sprocket.

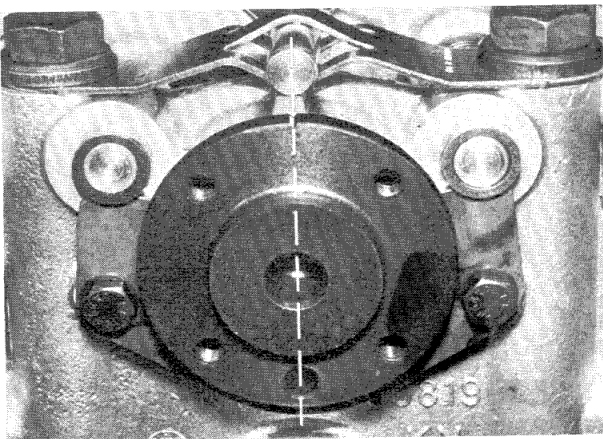

Note when fitting: Fit chain in such a way that the hole for the dowel pin faces downwards. The notch in the camshaft flange must be aligned with the cast projection in the cylinder head.

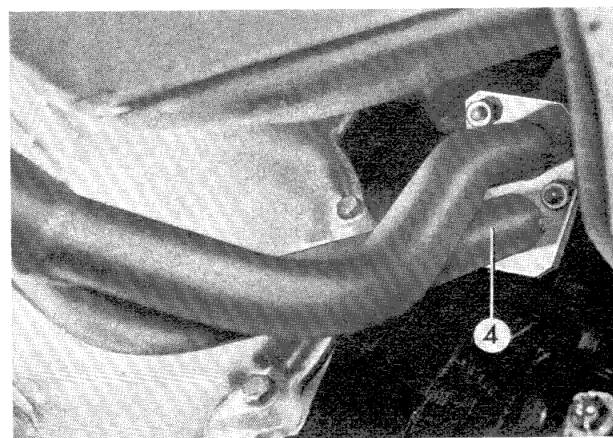

Remove exhaust pipe (4) from exhaust manifold.

Note when fitting: If loud drumming is heard, fasten exhaust pipe (4) to the gearbox free of tension with support element; see 18 00 020.

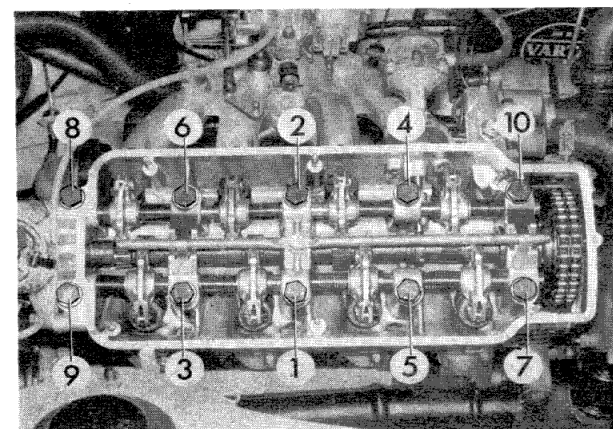

Unscrew cylinder head bolts and remove cylinder head.

Note when fitting: Tighten bolts 1... 10 in series, working in three consecutive operations¹⁾.

Run engine until it reaches normal operating temperature. After testing, let engine cool to 35° C (95° F).

Tighten cylinder head bolts finally¹⁾.

Note: After 1000 km (app. 600 miles), take up slack at cylinder head bolts. First loosen bolts slightly, then tighten to specified torque.



¹⁾ See specifications

Note when fitting: Check overhang of guide sleeves for cylinder head and cylinder head sealing by measuring depth. Max. overhang A: 5 mm (0.1968").

Important: Make sure there is no oil in the blind holes, as there is otherwise a risk that although the bolts are tightened to the prescribed torque they will not bear on the cylinder head with the force required. There is also a risk that the cylinder crankcase will crack.

The cylinder head sealing must always be replaced and cannot be used again.

Adjust valve clearance cf. 11 34 004.

Adjust engine idle speed cf. 13 00 004.

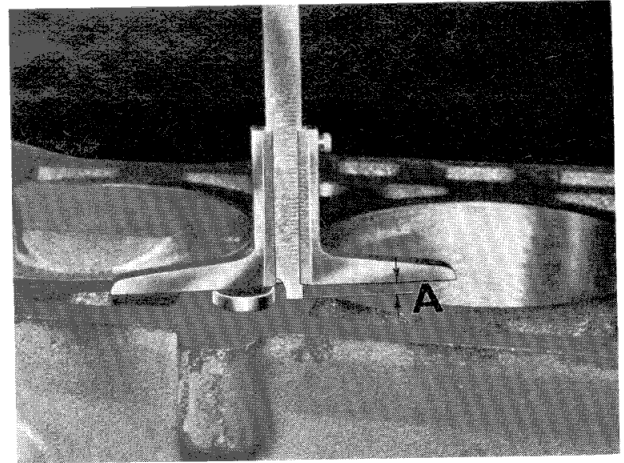

11 12 101 Replacement of cylinder head sealing

Remove cylinder cf. 11 12 100.

Make sure that the sealing surfaces on the cylinder head and crankcase are perfectly clean.

Note when fitting: Always use original cylinder head sealings only, as the holes for coolant flow must be at exactly the right places.

Important: Note that the cylinder head sealing of the 2002 TI can be used on the 2002.

However, it is not permissible under any circumstances to use the cylinder head sealing of the 2002 engine in the 2002 TI engine.

- (1) Sealing with normal top land
- (2) Sealing for TI and tii with reinforced top land
- (3) Sealing for TI and tii with serrated ring

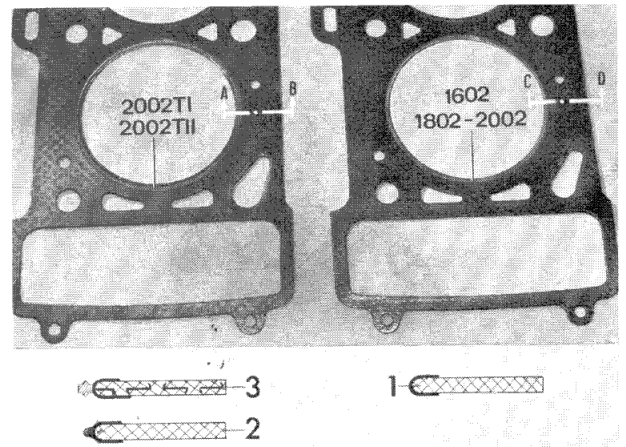

Note when fitting: Coat cylinder head sealing with Atmosite or Curil K2 in the region of the gearbox surface.

If necessary plane cylinder head surface cf. 11 12 719.

Important: Tighten cylinder head bolts after 1,000 km (600 miles).

When tightening, first loosen bolts somewhat and then tighten to prescribed torque.

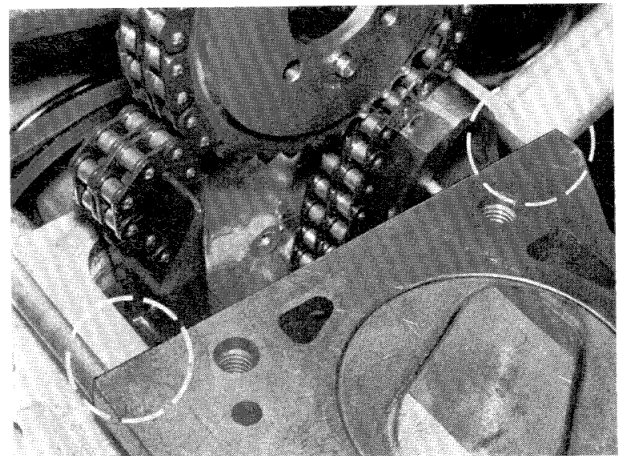

11 12 161 Replacement of cylinder head

Disassemble cylinder head when removed.

Check which parts can be used again and replace other parts.

Polish valve surfaces.

Important: Combustion chamber of two-litre engines has been modified. Modification marked on cylinder head E 12.

The thermal rating¹⁾ of the spark plugs has also been changed.

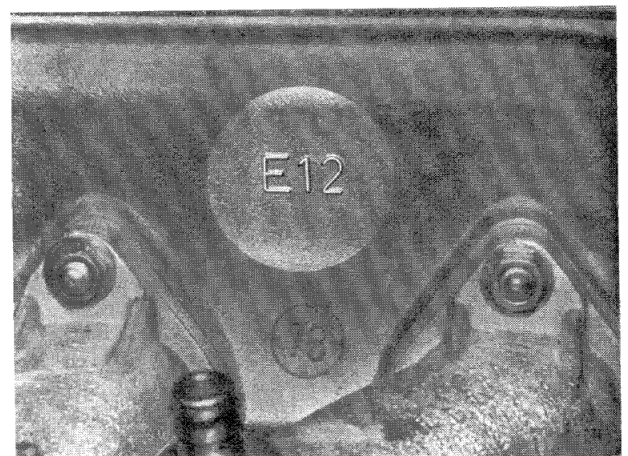

¹⁾ see Specifications for group 12—0/5

11 12 561 Replacement of one valve guide — with valve removed —

Check valve guide sleeve¹⁾ for wear.



If wear tolerance has been exceeded, force valve guide into the combustion chamber by using punch 609 (guide in cold condition).



Check cylinder head bore. If the maximum permissible diameter has been exceeded, ream bore surface and fit in an oversize¹⁾ valve guide.



Heat cylinder head¹⁾.
Working from the side where the camshaft is located, press valve guide into the combustion chamber. The conical groove must face towards the side where the camshaft located.

Important: The bore in punch 610 indicates fitting depth A 15—0.5 mm (0.5906—0.0197”).

Ream valve guide to prescribed inner diameter¹⁾.



¹⁾ see Specifications

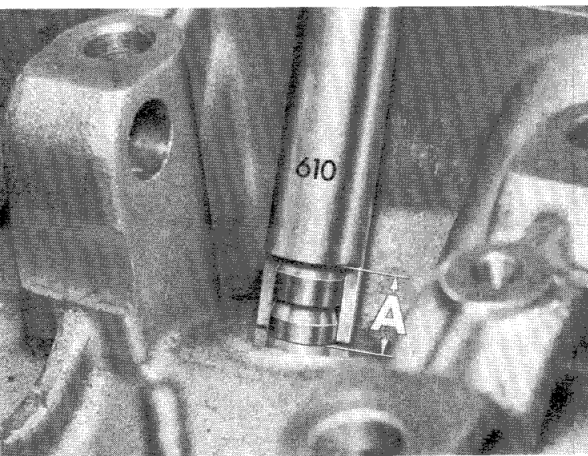
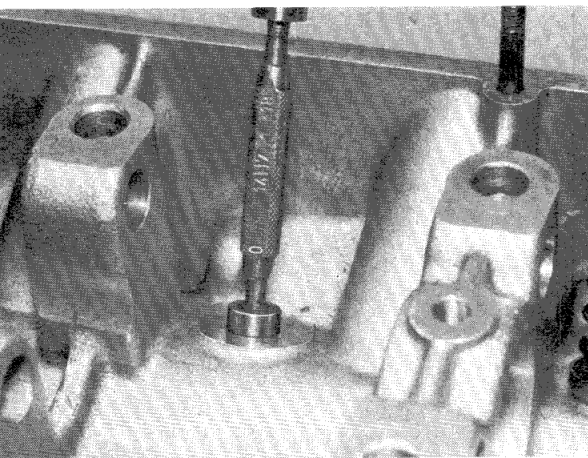
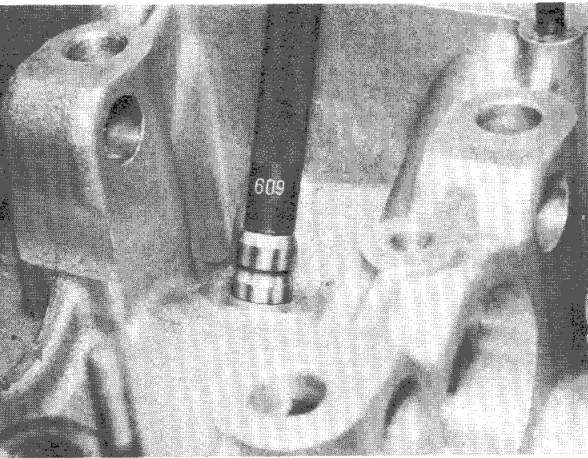
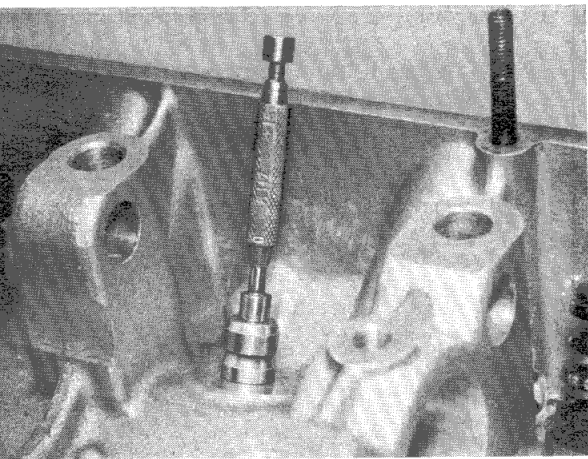

11 12 607 Valves and valve seats – refinishing – Cylinder head removed –

Note minimum edge thickness A¹⁾ and valve seat angle B.
The valve must be replaced if the minimum edge thickness
is not attained.

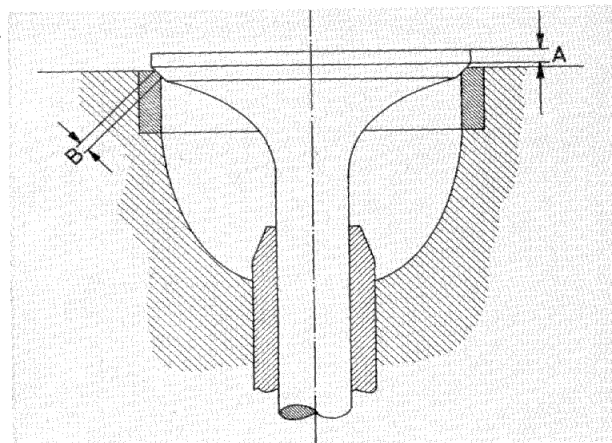

Reground valve seats must not have any chatter marks.

Fitting instruction: Check valves for leaks – petrol test
(11 34 509)

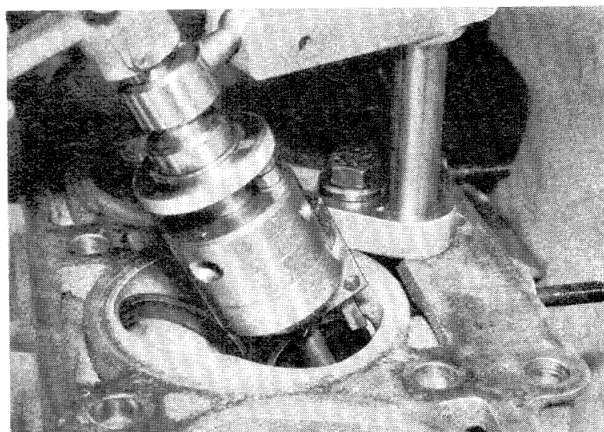

11 12 621 Renewing one valve seat

Remove valve seat ring by turning out of cylinder head
(e.g. with Hunger valve tool).

Fitting instruction: Drill out bore A in cylinder head to appropriate
oversize¹⁾.

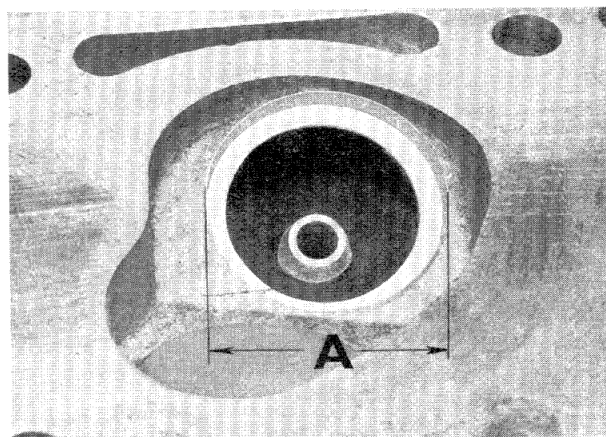

To fit suitable valve seat ring B into bore, heat cylinder
head¹⁾ and cool valve seat ring¹⁾ with dry ice.

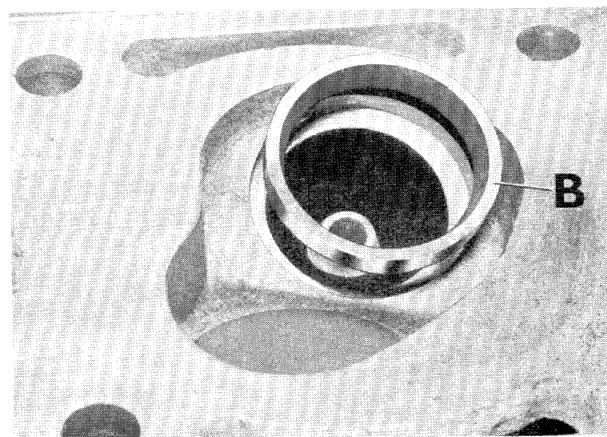

¹⁾ See specifications
9. 75 Alteration

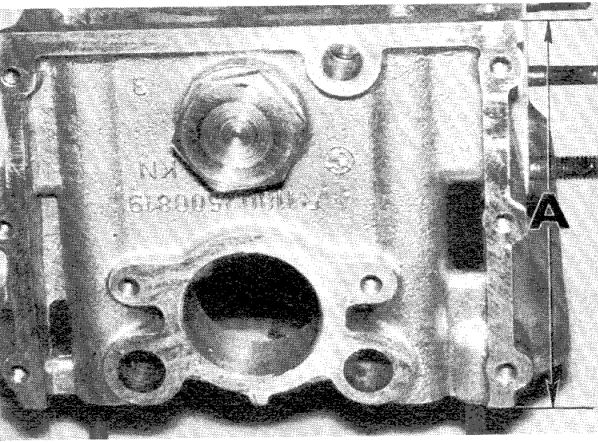

11 12 719 Cylinder head – skimming – head dismantled –

When refinishing the cylinder head sealing surface the total depth of the cylinder head – originally A 129 ± 0.1 mm (5.0787 ± 0.0039 in) must not be reduced by more than 0.5 mm (0.0197 in).

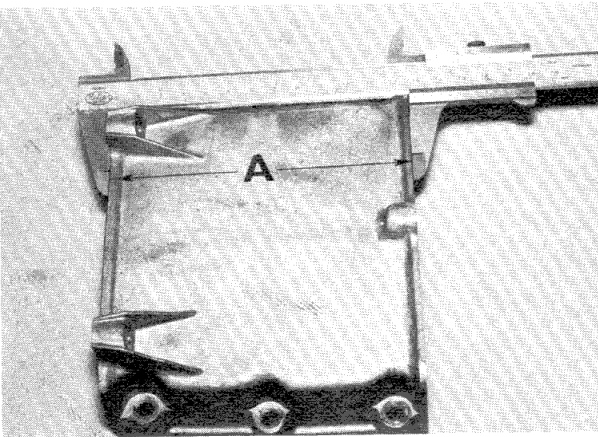

In addition the upper timing case cover must be refinished accordingly.



11 13 000 Removal and fitting of oil sump

(A) With engine in car

If applicable, remove and fit stabilizer bar, cf. 31 35 000.

Drain engine oil.

Remove oil sump.

Detach both engine supports.

Using hoist 600, lift engine slightly.

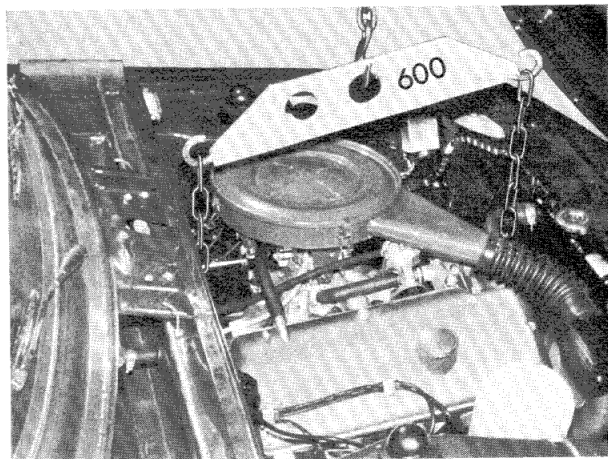

Adjust connecting rod on cylinder 4 to TDC.

Remove oil sump to the front.

Note when fitting: Cf. instructions for this operation when engine is removed.

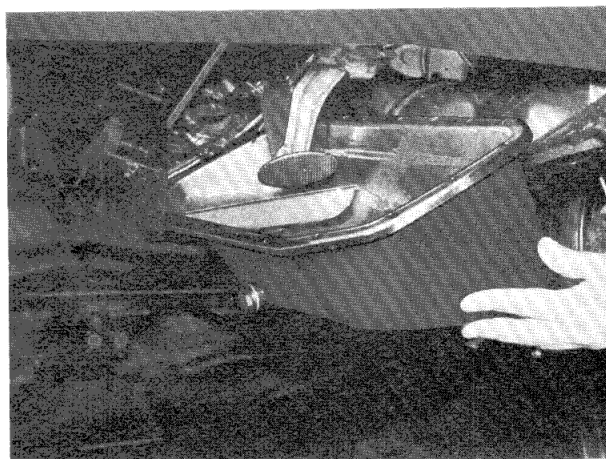

(B) With engine removed

Remove oil sump.

Note when fitting: Clean sealing surface.

Coat contact surfaces on gearbox cover and cover next to clutch with Atmosite or Curil K2.

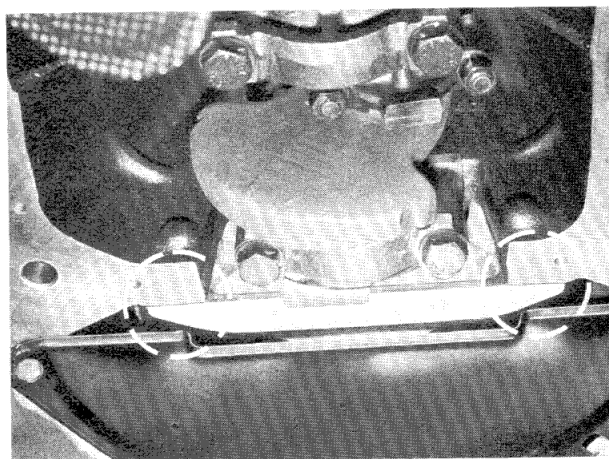
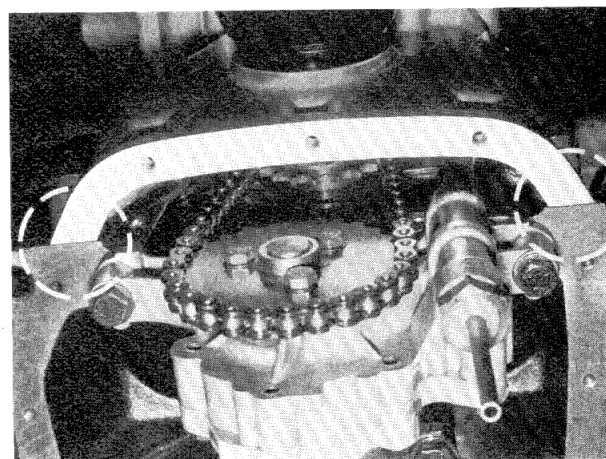

11 14 100 Removal and fitting of upper timing case cover

Removal of cylinder head – 11 12 200.
Detach timing case cover.

Note when fitting: Tighten bolts 1 and 2 lightly. Then tighten bolts 3 . . . 8, working in series, and finally tighten bolts 1 and 2 until they are secure.
Secure alternator earth cable to bolt 4.

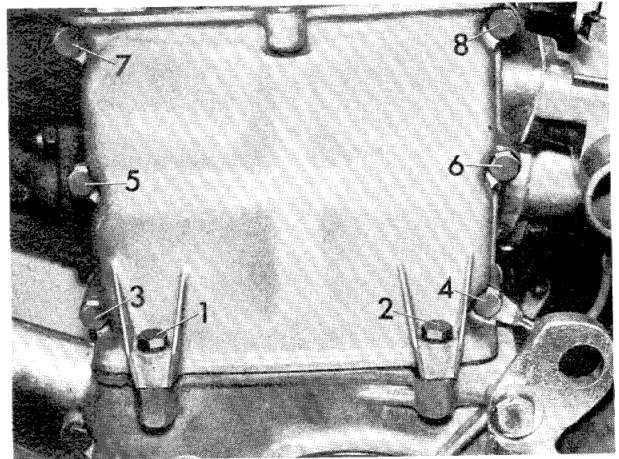

Note when fitting: To avoid oil leaks, use only "Cabritol" gaskets. Coat surfaces between cylinder head and timing case cover with Atmosit or Curil K2.
If the cylinder head gasket is damaged during this operation it must be replaced. For replacing cylinder head gasket, remove cylinder head – 11 12 100.

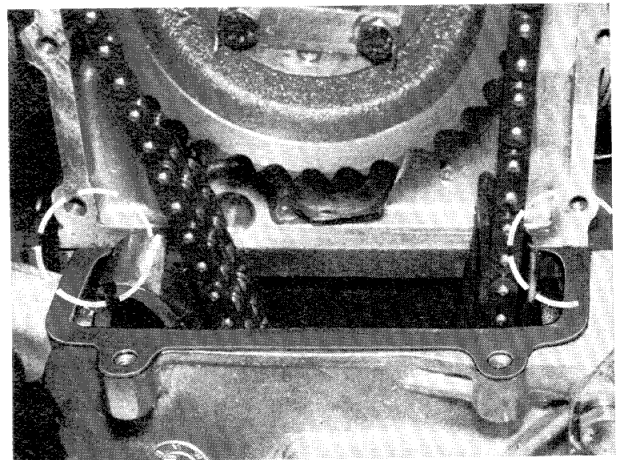

11 14 120 Removal and fitting of upper and lower timing case covers

Disconnect earth strap from battery.
Remove water pump 11 51 100.
Removal of upper timing case cover – 11 14 100.
Removal of chain tensioner piston – 11 31 090.
Disconnect plug and cable from alternator.

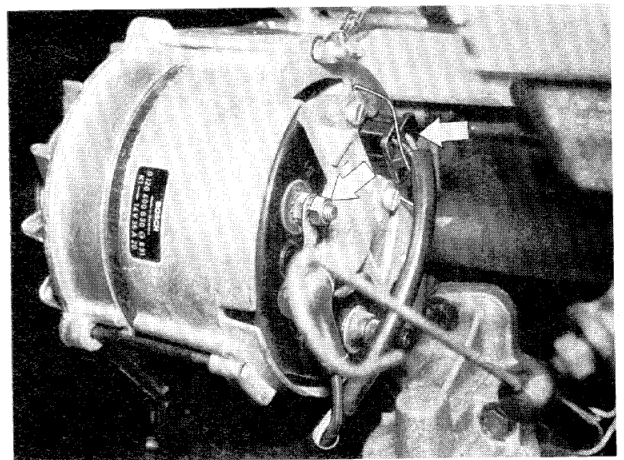

Remove alternator with bearing support and tensioning strap.

Note when fitting: Check tensioning strap pivot bushing and replace if necessary (see 12 31 361).

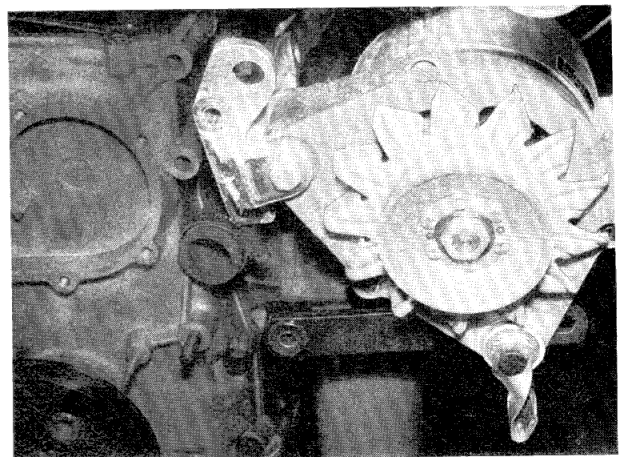

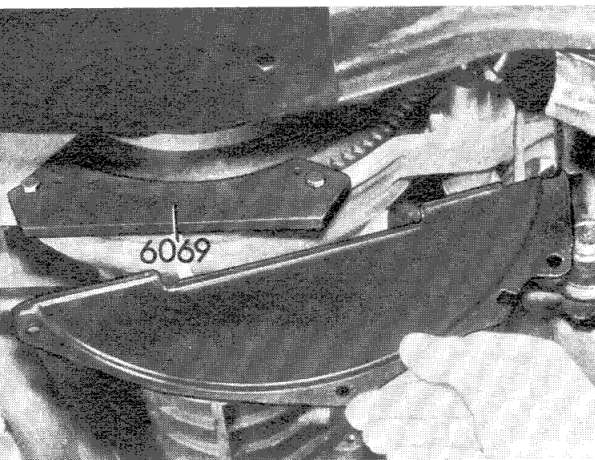

Remove cover plate.
Using tool 6069, lock flywheel.

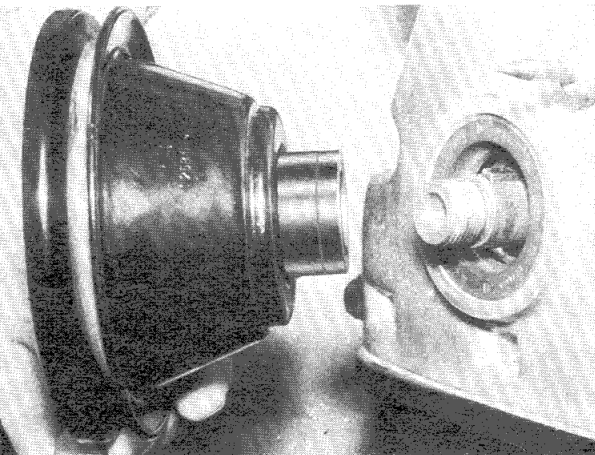

Loosen nut¹⁾ on pulley.
Pull off pulley.

Note when fitting: If hub is considerably worn, insert sealing ring in such a way that the sealing lip is in front or behind the groove caused by wear.

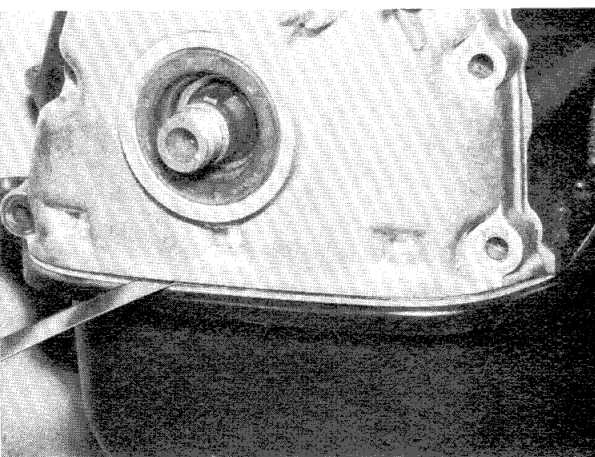

Unscrew bolts on timing case cover and at front of the oil sump.

Important: Carefully remove oil sump gasket from the timing case cover, using a knife.

If the oil sump gasket is damaged in the process, it must be replaced. For replacing the oil sump gasket, remove oil sump – 11 13 000.

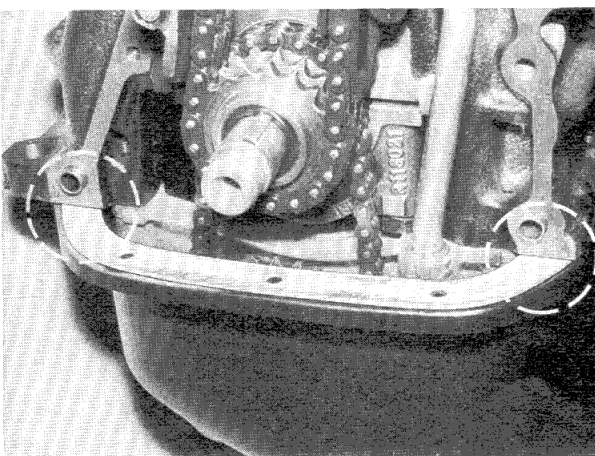

Remove timing case cover.

Note when fitting: To avoid oil leaks, use only "Cobritol" gaskets. Coat surfaces between oil sump and crankcase with Atmosit or Curil K2.

Important: Make sure that the support web for the chain tensioner piston is in the oil pocket.



) see Specifications for tightening torques

11 14 411 Replacement of radial sealing ring in timing case cover

Remove radiator – 17 11 000.
Loosen alternator.
Take off V-belt.
Remove cover plate.
Using tool 6069, lock flywheel.

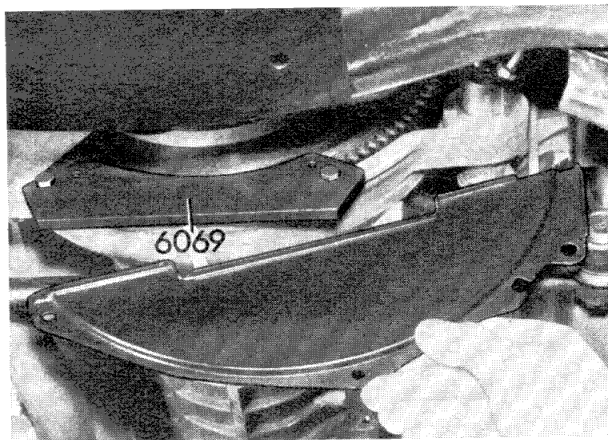

Remove nut¹⁾ from pulley.
Pull off pulley.
Using tool 7051, pull off radial sealing ring.

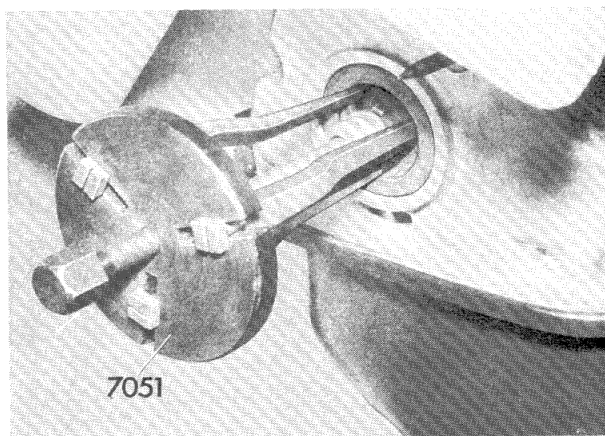

Note when fitting: If hub is considerably worn, insert sealing ring in such a way that the sealing lip is in front of or behind the groove caused by wear.

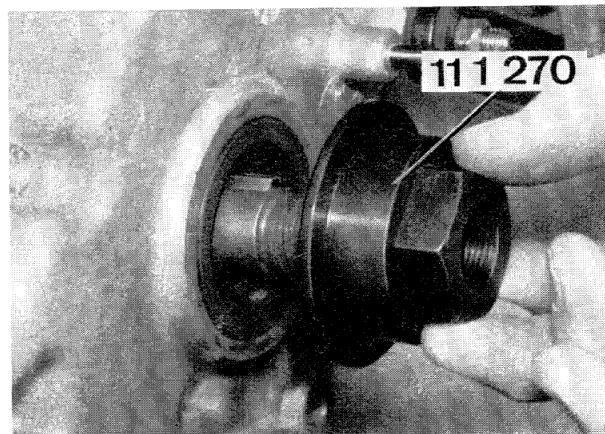

11 14 611 Replacement of radial sealing ring in clutch end cover – flywheel removed –

Loosen oil sump slightly at rear.
Using a knife, carefully remove the oil sump gasket at the cover joint.
Take off cover.
Press radial sealing ring out of cover.

Note when fitting: Coat contact surface between the cover and the oil sump with Atmosit or Curil K2.
If the oil sump gasket is damaged in the process, it must be replaced. To replace the oil sump gasket, remove the oil sump – 11 13 000.

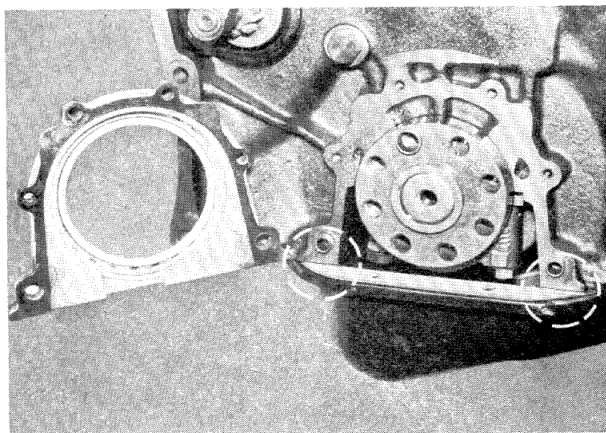

¹⁾ see Specifications for tightening torques

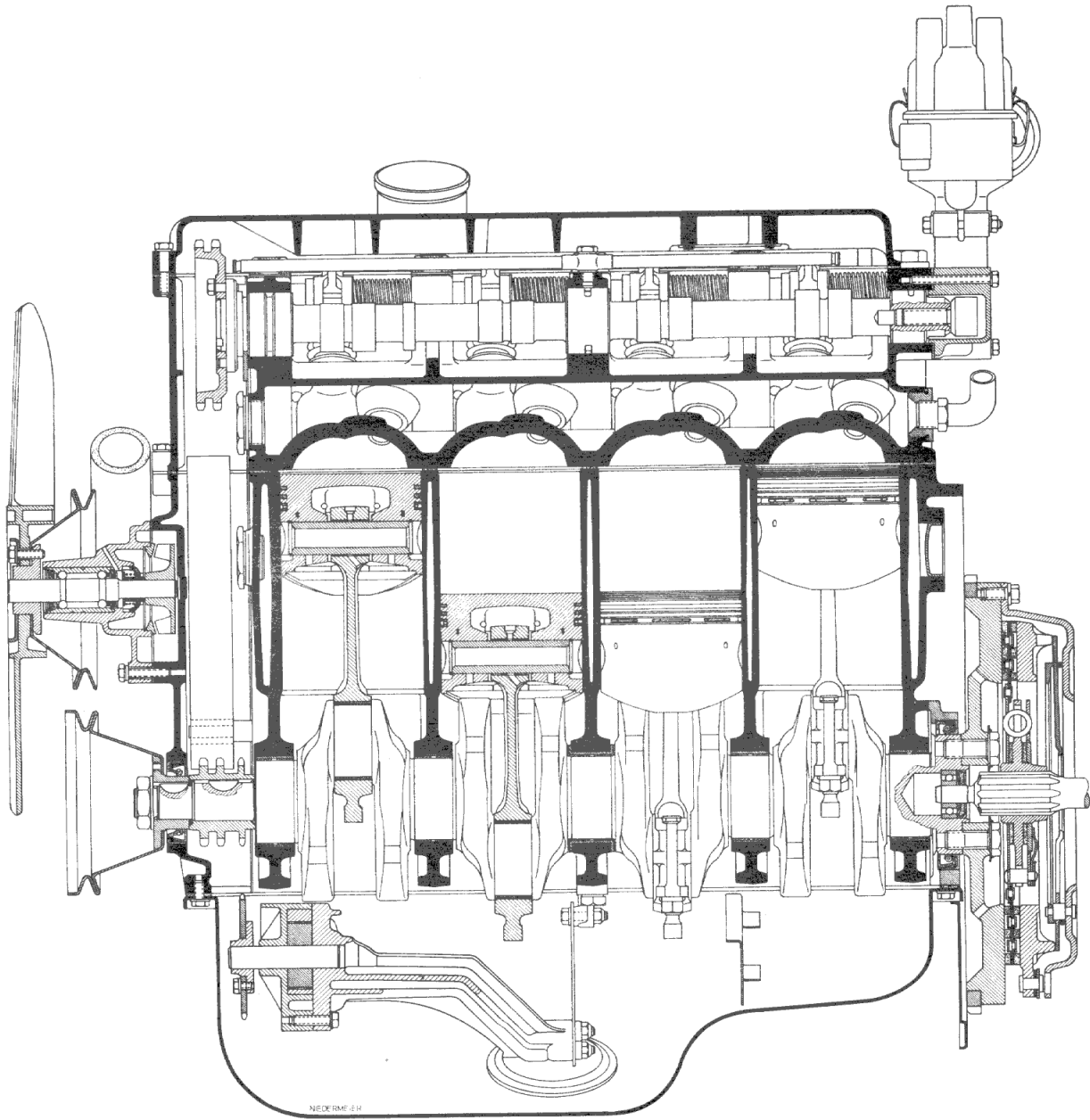

Engine – longitudinal section

11 21 000 Removal and fitting of cranks-haft

Remove engine – 11 00 050.

Using assembly plate 6001, fasten crankcase to assembly support.

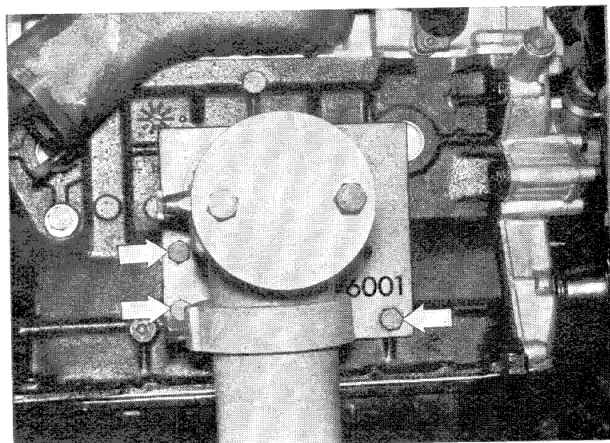

Remove clutch – 21 21 000.

Remove timing chain – 11 31 550.

Remove oil pump – 11 41 000.

Measure axial¹⁾ play before removing crankshaft.

If the maximum play limit is exceeded, check main bearing.

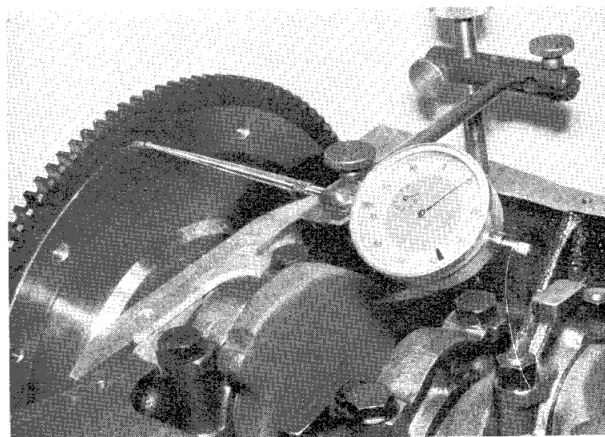

Remove flywheel – 11 22 000.

Take off end cover.

Note when fitting: Coat contact surfaces between the end cover and the oil sump with Atmosit or Curil K2.

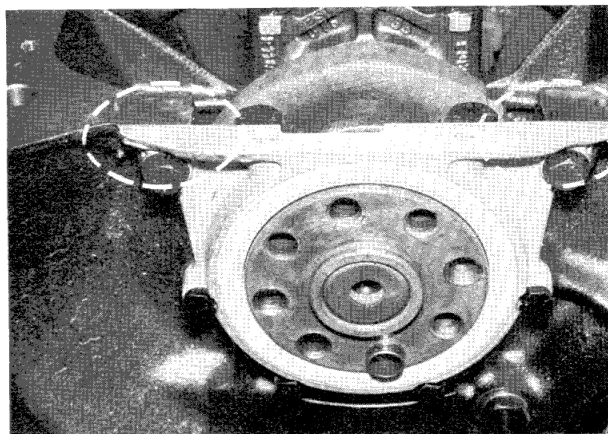

With pistons at BDC, remove connecting rod big end bearing caps.

Note when fitting: The connecting rods and bearing caps are marked in relation to each cylinder.

Connecting rod 1 is at the same side as the sprocket. Always make sure that these cylinder reference figures and/or work figures are on the same side.

The narrow collar of the nuts must face towards the bearing cap.

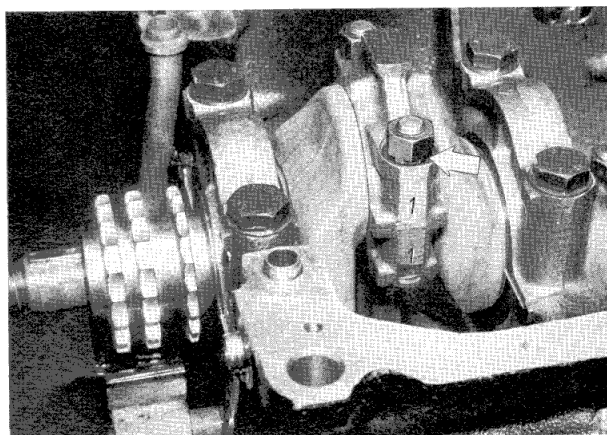

¹⁾ See specifications

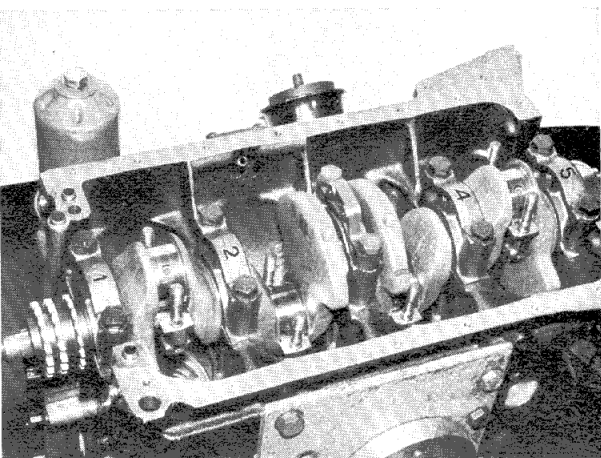

Remove main bearing caps.
Take out crankshaft.

Note when fitting: Do not interchange bearing caps.
Make sure that bearing cap 1 is at the same side as the sprocket.

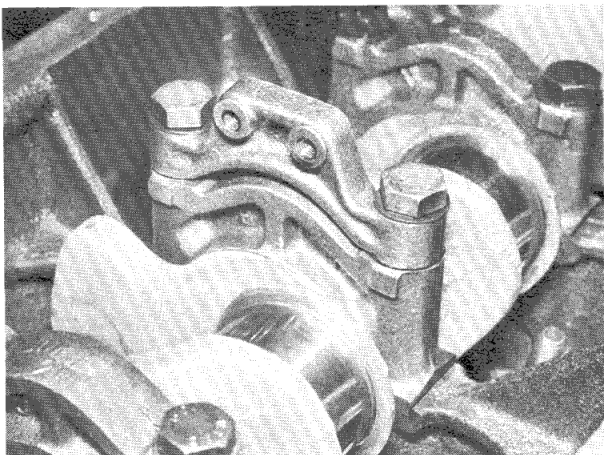

Note when fitting:
Fasten oil pump support member to bearing cap 3.
Bearing 3 is the guide bearing.

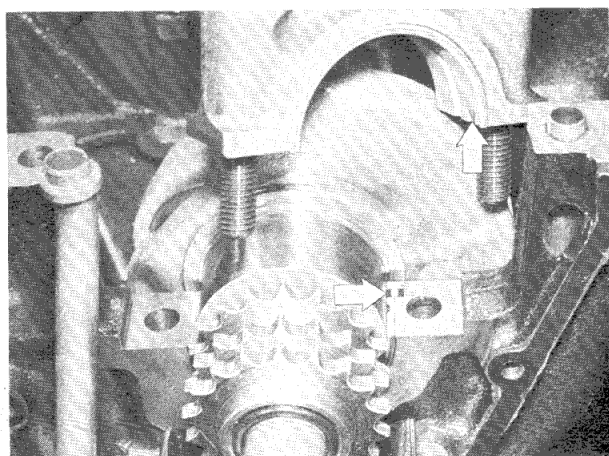

Note when fitting: When fitting crankshaft bearing caps, make sure that the two grooves coincide.

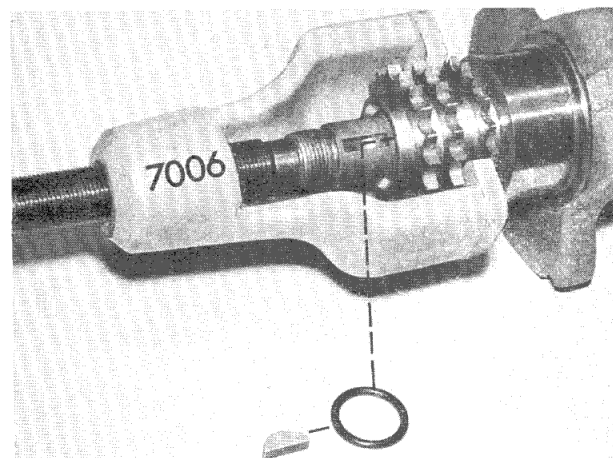

11 21 501 Replacement of crankshaft – crankshaft removed –

Remove Woodruff key.
Take out O-ring.
Using tool 7006, pull off sprocket.

When installing: The O-ring can be omitted.
Heat the chain sprocket.

Transfer ball bearing²⁾ – 11 21 571.

The crankshafts can be distinguished by the following features:

Forging number on the crank web.

		8 hohle	6 hole
BMW 1502	}	1252788 or only 788	1150310504.1
1602			
1802			
BMW 2002	}	1252126 or only 126	1210310580.1
2002 A			
2002 Ti			
2002 tii			

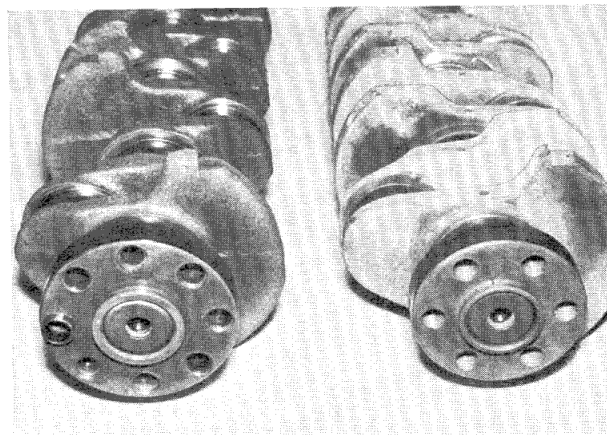

Crankshaft marking:

Original¹⁾: one red or blue dot at the side on the balance weights.

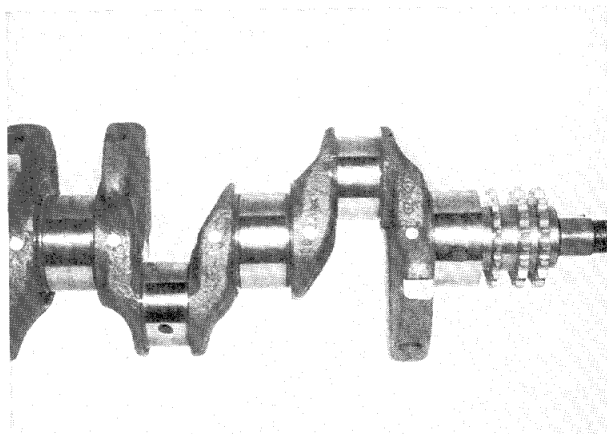

Reground crankshafts are marked by coloured lines.

Big end bearing journal (A)

- 1 paint stripe – reground to stage 1¹⁾
- 2 paint stripes – reground to stage 2¹⁾
- 3 paint stripes – reground to stage 3¹⁾

Main bearing journal (B)

- 1 paint stripe – reground to stage 1¹⁾
- 2 paint stripes – reground to stage 2¹⁾
- 3 paint stripes – reground to stage 3¹⁾

Important: Note that the crankshaft is hardened by the "Tenifer" method and may only be reground at the factory.

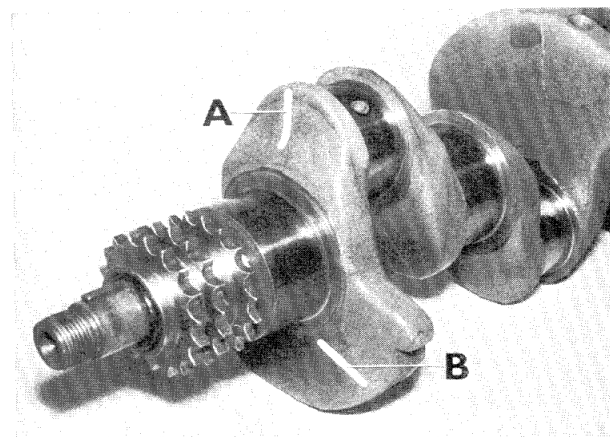

Always fit bearing shells to match the journal diameter selected. This means that the bearing shells must bear the same red or blue marks as the crankshaft itself.

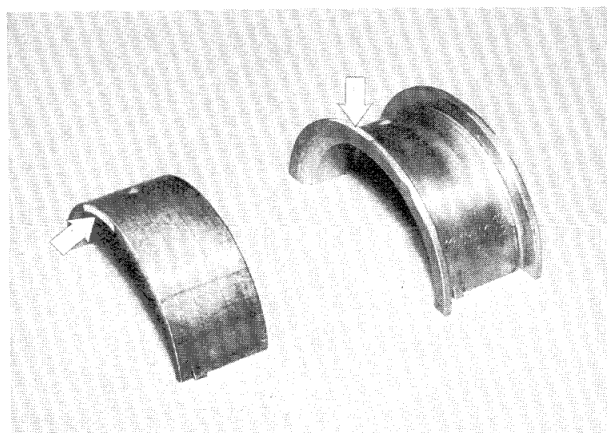

¹⁾ See specifications

¹⁾ except for 2002 A

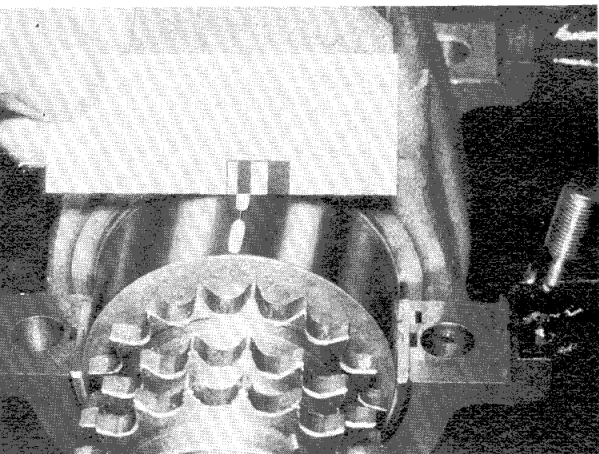

Using Plastigage Type PG 1, check bearing play¹⁾.

- a) Measure each bearing individually.
- b) Make sure that the bearing surface is oil-dry.
- c) Measure with crankshaft at dead centre.
- d) Tighten bearing cap to prescribed torque¹⁾.
- e) Do not turn crankshaft while measuring.
- f) With the help of the indicator scale, measure bearing play¹⁾ at the width of the flattened plastic strip.

Plastigage available in Germany from:
Messrs. ERN, Düsseldorf, Corneliusstr. 65/66.

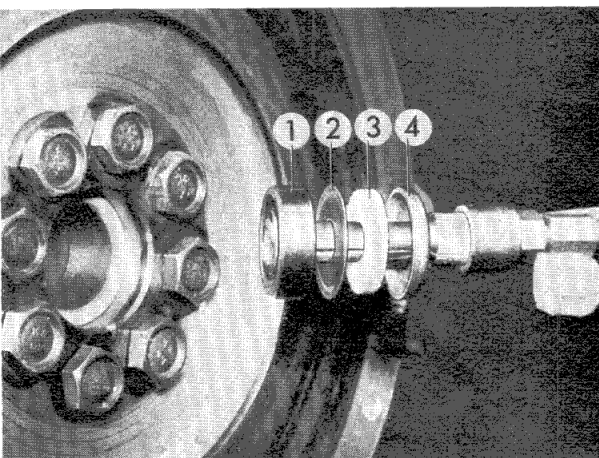

11 21 571 Replacement of ball bearing in crankshaft

Together with cover plate, felt ring and cap, pull bearing out of crankshaft (using Kukko puller).

Note when fitting:

Pack ball bearing (1) with branded multi-purpose grease with a drop-point of 180° C (356° F).

Fit cover plate (2) with symbol facing to the outside.

Soak felt ring (3) in hot tallow.

Force in cap (4) until it is a tight fit.



¹⁾ See specifications

11 22 000 Flywheel — removing and fitting

Remove clutch. 21 21 000.
Check flywheel for axial runout¹⁾.

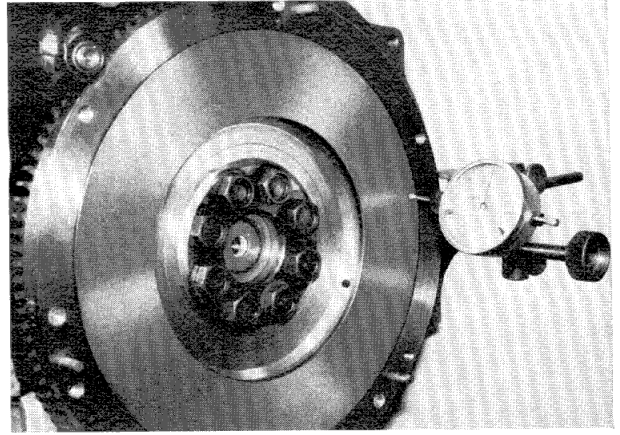

Lock flywheel with retainer 7007.
Only on models without adaptor sleeves.
**Mark fitted position of flywheel/crankshaft
(dynamic ignition timing mark).**

Unscrew expansion bolts.

Note: Renew expansion bolts and fit with Loctite red
Code No. 41 and Aktivator T for faster hardening.
Carefully clean threaded holes.

Take off flywheel.

Note bolt length.

BMW 1600-2 and 2002 A = 22 mm (0.866")
2002 and 2002 TI = 28 mm (1.102")

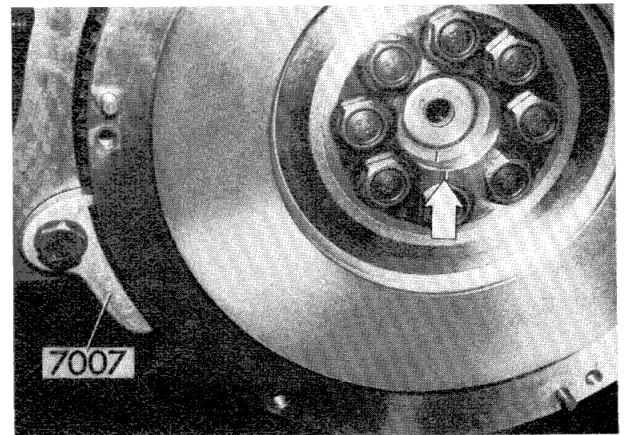

In the case of flywheels with 6-hole mounting, press
off the retaining plate.

Fitting instruction: The retaining plate may only be
used once.

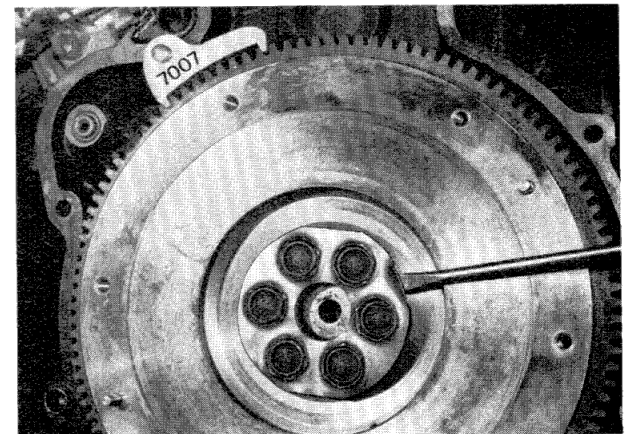

Fitting instruction: Regrinding¹⁾ of the friction surface
is permitted. The wall thickness within the friction
area must not be less than 13.5 mm (A) (0.5315")

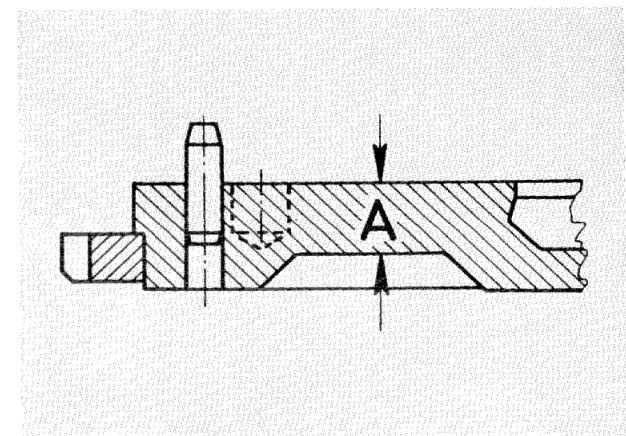

1) see technical data

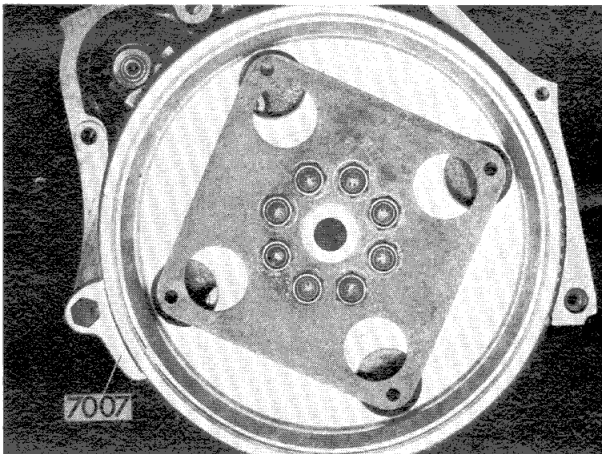

11 22 051 Driving disc for torque converter — renewing

Remove gearbox. 24 00 020.
Lock flywheel with retainer 7007.
Unscrew expansion bolts.
Renew driving disc.

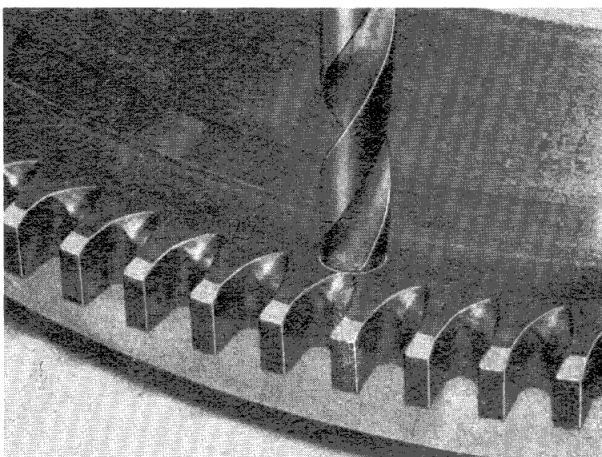

11 22 541 Starter ring — renewing

To facilitate separation drill ring gear approx. 8 mm (0.315") deep under one tooth space with a 6 mm drill.

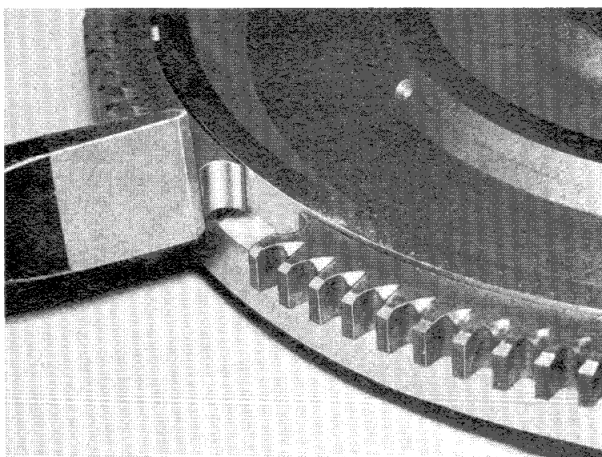

Split ring gear at drilled spot with a chisel.

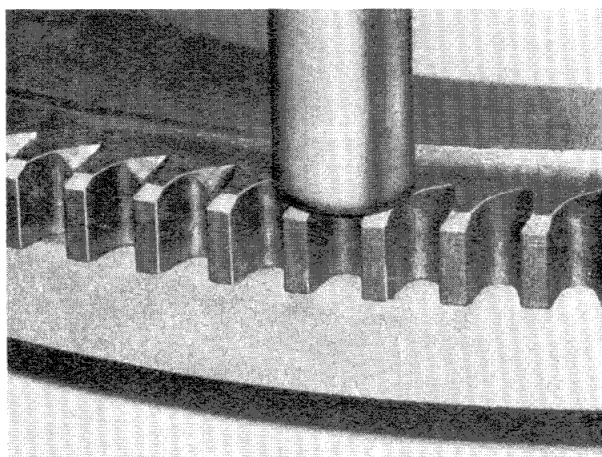

Fitting instruction: Heat new starter ring gear to 200 — 230° C (400 - 450° F). Use a thermochrome pin for this purpose. The tooth chamfer faces the engine side. Locate starter ring gear fully with brass punch.



11 24 501 Replacement of one connecting rod — with piston removed —

Important: In one engine, always fit in connecting rods belonging to the same weight group with an overall tolerance of ± 4 g (0.140 ozs.) (without bearing sleeves).

The weight group is shown the colour mark.

If no colour mark is visible, remove and weight another connecting rod for comparison.

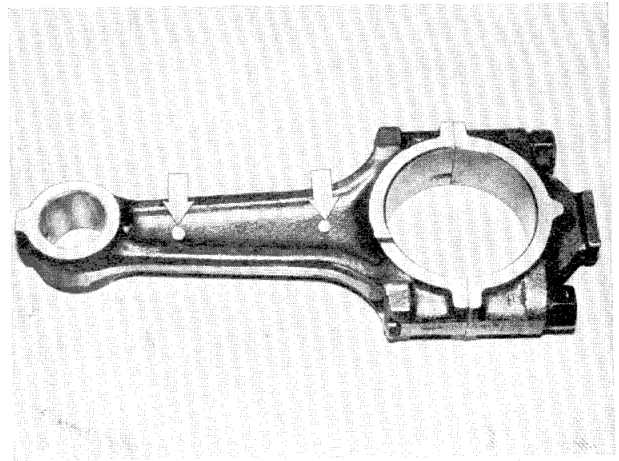

Fit connecting rod bearing sleeves into connecting rod. Place Plastigage Type PG 1 crankshaft bearing journal free of oil.

Fasten connecting rod to crankshaft.

The serial numbers must be on the same side.

Make sure that the oil flow hole in the connecting rod eye faces towards the timing chain.

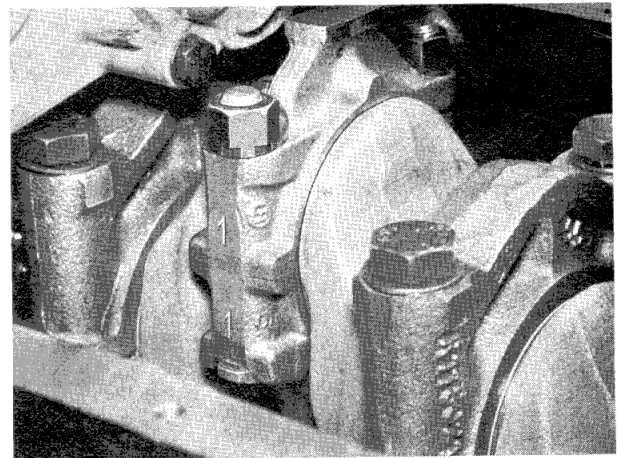

Tighten bearing cover to prescribed torque¹⁾.

Important: Do not turn connecting rod or crankshaft. Remove bearing cover.

With the help of the indicator scale, measure bearing play¹⁾ at the width of the squashed plastic thread.

Plastigage available in Germany from:
Messrs. ERN, Düsseldorf, Corneliusstr. 65/66.

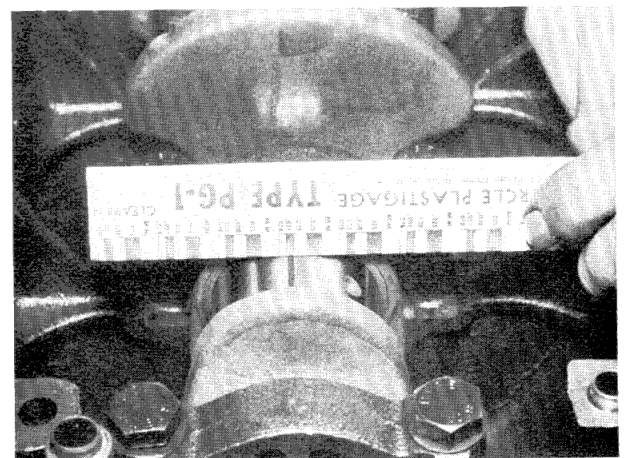

11 24 601 Replacement of one connecting rod bush — with connecting rod removed —

Connecting rods with reworked connecting rod bushes are available from our Spare Parts Supply Service. Force out old connecting rod bush.

Note when fitting: Press in new connecting rod bush so that the thrust end is at an angle of 90° to the oil flow hole.

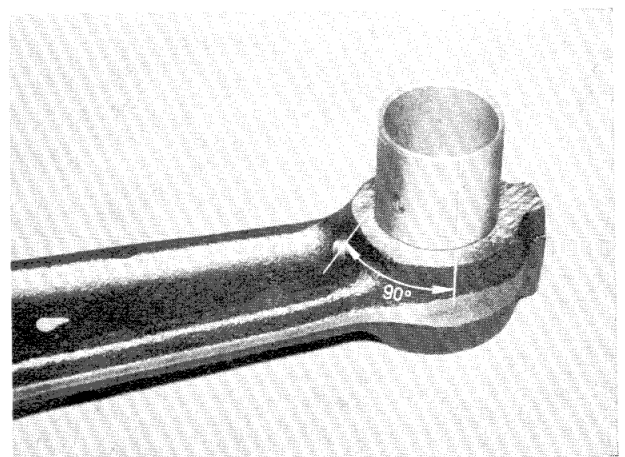

¹⁾ see Specifications

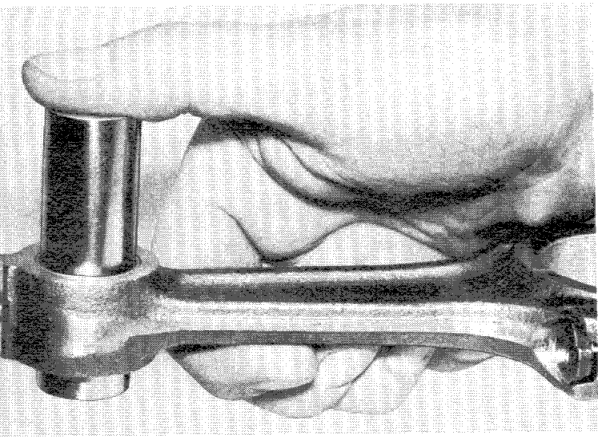

Drill oil flow holes, clean and make sure they are free of any metal residues.

Ream connecting rod bush¹⁾.

The piston pin must be able to slide through the connecting rod bush when subject to slight pressure.

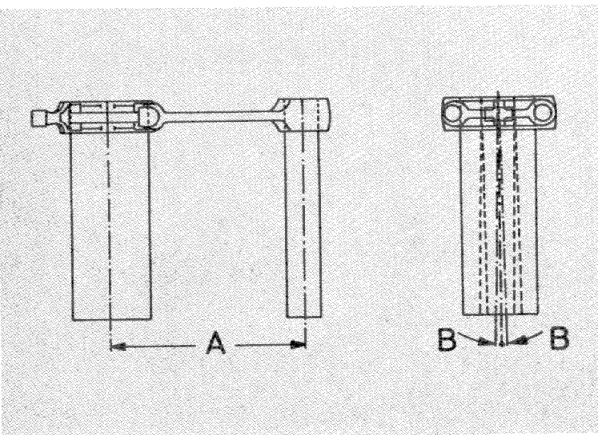

Check connecting rod for parallel alignment (A) and max. permissible distortion (B), and align if necessary.

A = 150—0.04 mm (5.9055—0.00158")

B = 0°—30'



¹⁾ for piston pin play when running, see Specifications

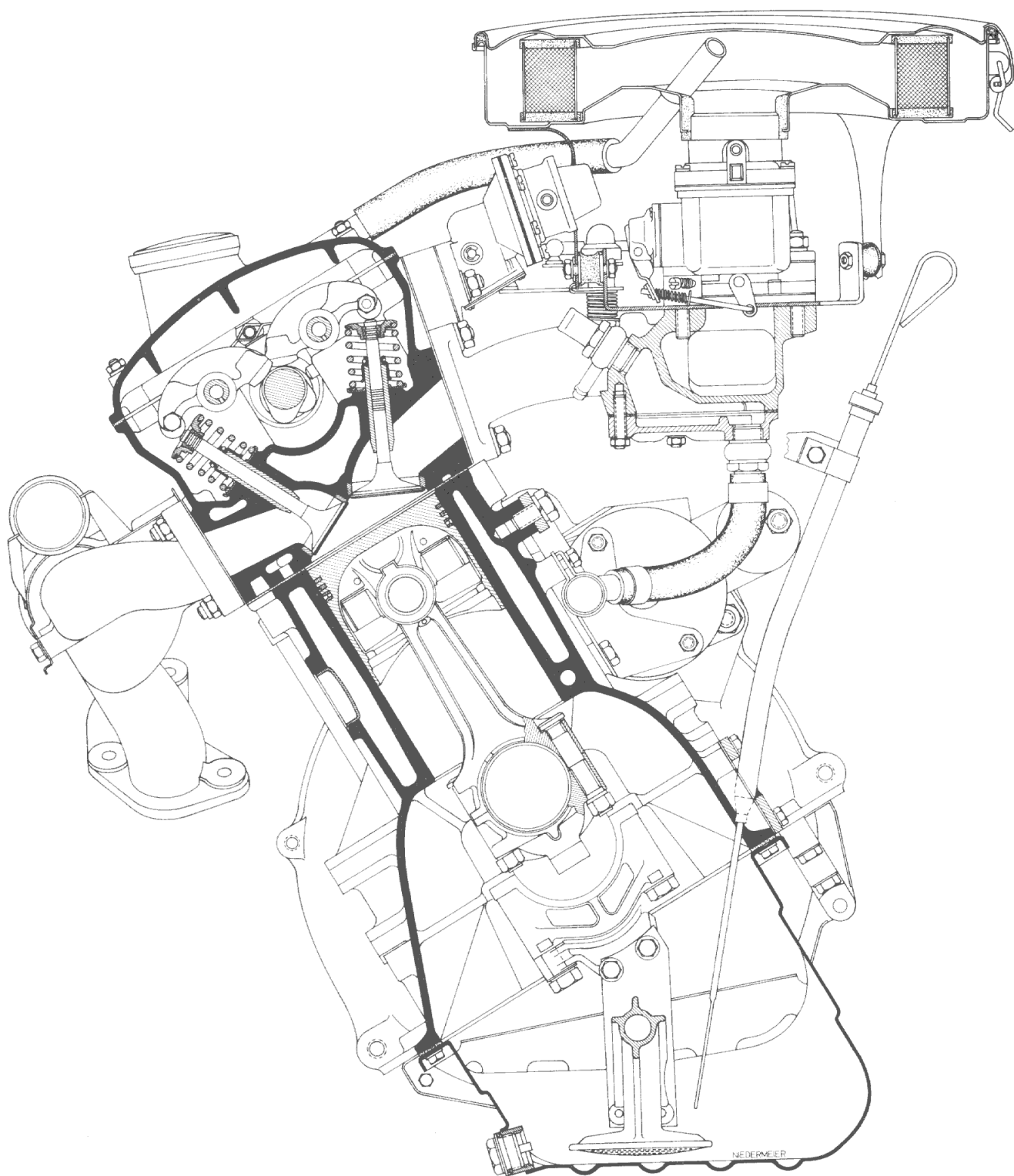

Cross-sectional view of carburetor engine

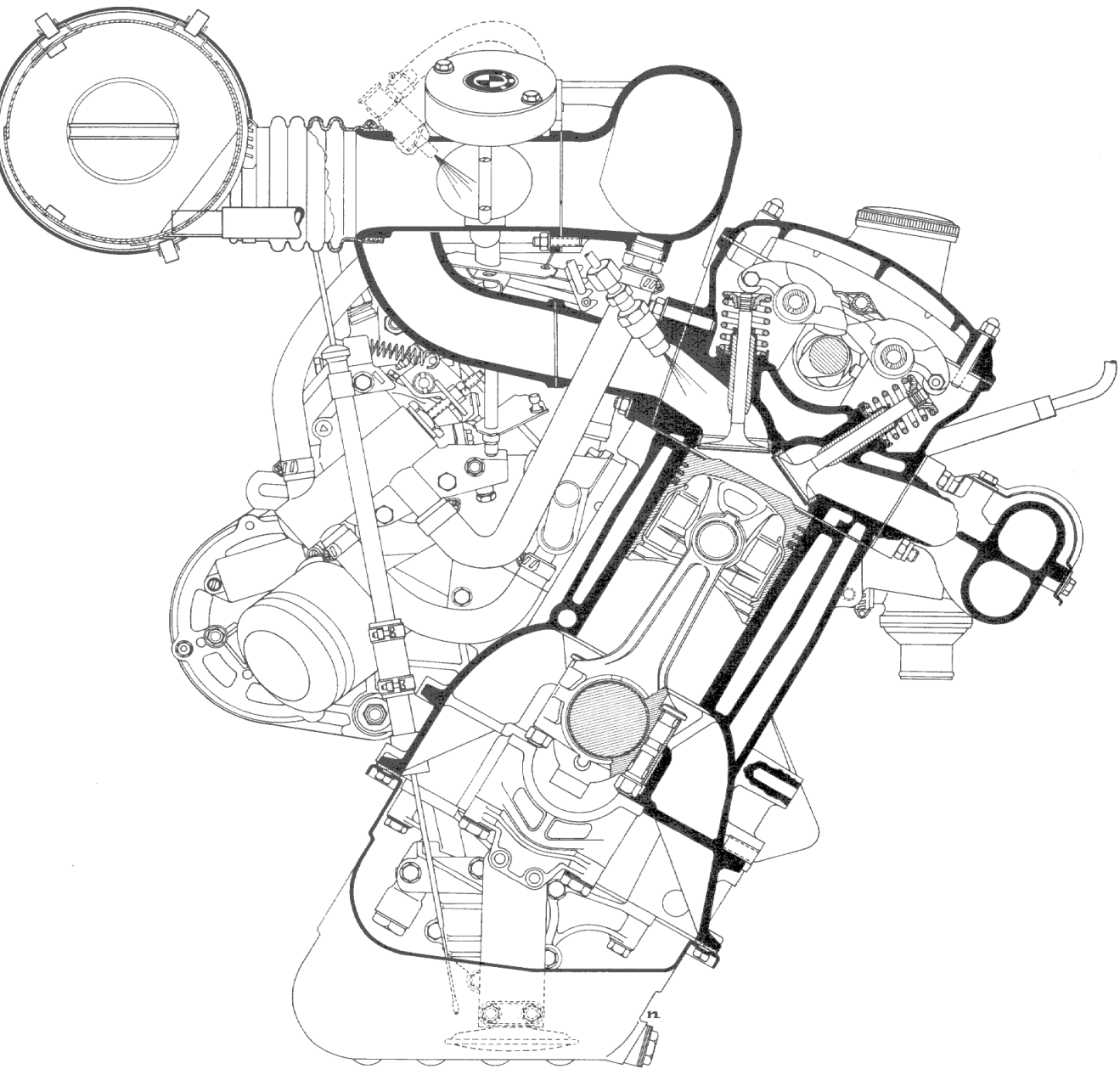

Cross-sectional view of injection engine

11 25 500 Removal and fitting of one piston

Remove cylinder head – 11 12 100.

Remove oil sump – 11 13 000.

Remove connecting rod bearing cap with piston at BDC.

Note when fitting: The connecting rod and the bearing cap are marked to match each cylinder.

Make sure that connecting rod 1 is at the same side as the sprocket.

Make sure that the cylinder reference figures and the machining numbers are always on the same side.

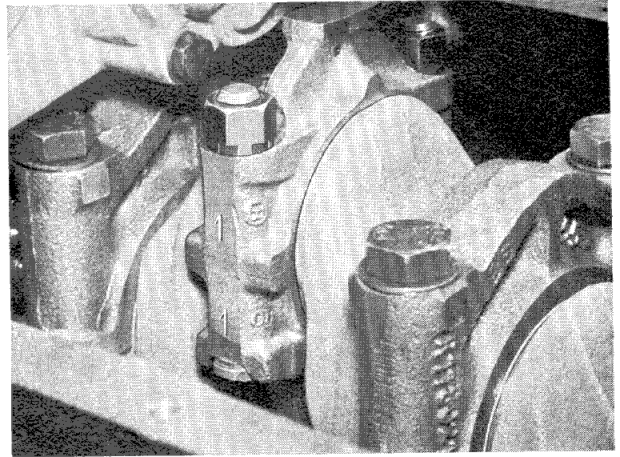

Press piston and connecting rod out upwards.

Note when fitting: Locate piston ring gaps at 180° from one another.

The arrow on the piston crown must face towards the timing chain.

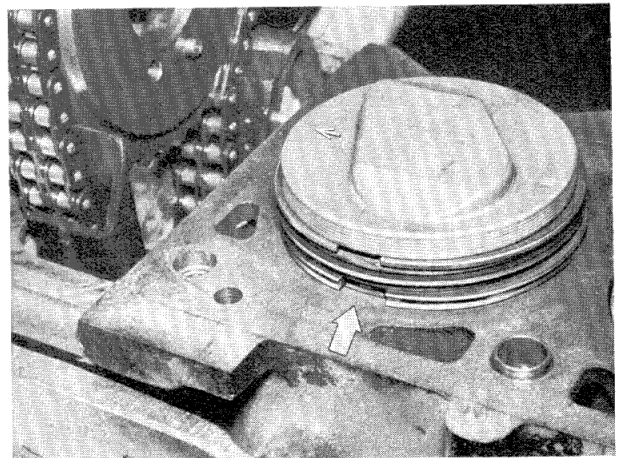

Remove piston pin.

Note when fitting: The oil hole in the connecting rod small end bushing must face in the same direction as the arrow on the piston.

Important: Always use pistons of the same make and the same weight group¹⁾.

The weight group is indicated by a + or – stamped on the bottom of the piston.

Check piston play when assembled¹⁾.

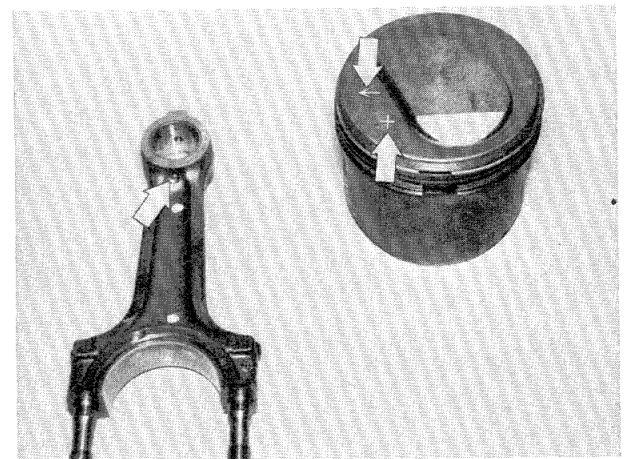

Measuring point A for pistons made by

Messrs. Mahle:

BMW 1502	15.8 mm (0.6209 in)
1602	16.7 mm (0.6575 in)
1802	14.3 mm (0.5630 in)
2002	} 16.0 mm (0.6299 in)
2002 A	
2002 T1	
2002 tii	16.5 mm (0.6496 in)

Measuring point A for pistons made by

Messrs. KS:

BMW 1502	25.35 mm (0.9980 in)
1602	24.5 mm (0.9646 in)
1802	28.85 mm (1.1358 in)
2002	} 16.05 mm (0.6319 in)
2002 A	
2002 T1	
2002 tii	23.35 mm (0.9193 in)

Measuring point A for pistons made by

Messrs. Nüral:

BMW 1602	11.0 mm (0.4331 in)
2002	} 15.9 mm (0.6260 in)
2002 A	

Measuring point A for pistons made by

Messrs. Alcan:

BMW 1802	13.2 mm (0.5197 in)
----------	---------------------

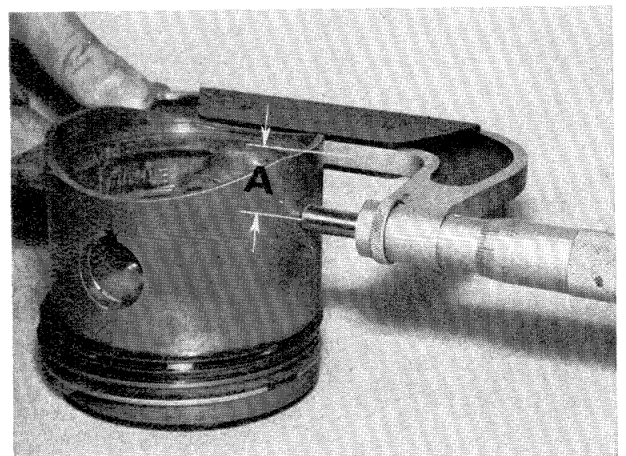

¹⁾ See specifications

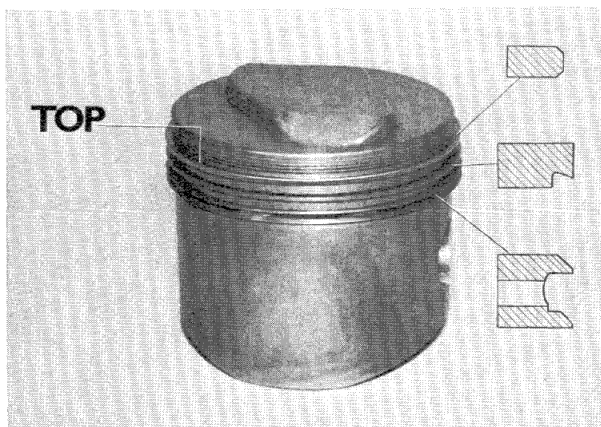
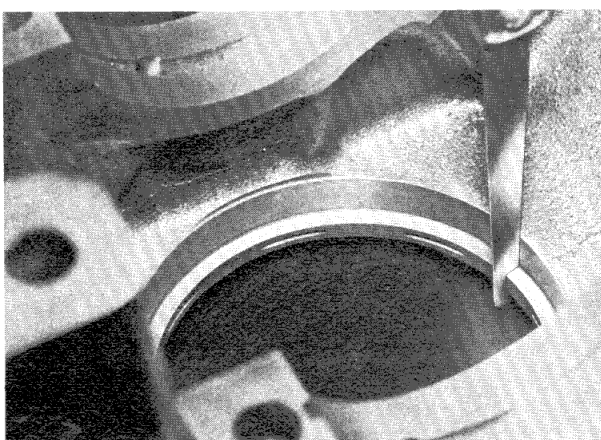
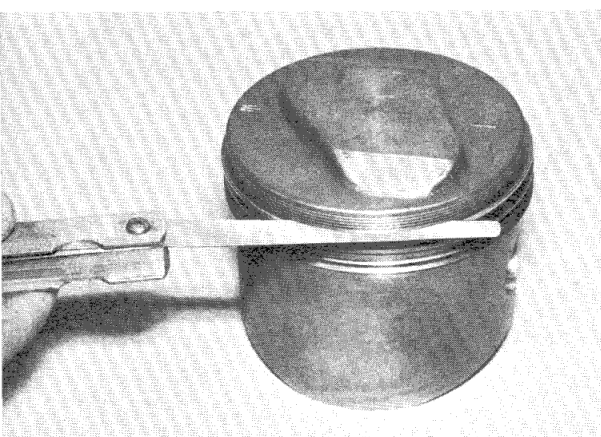
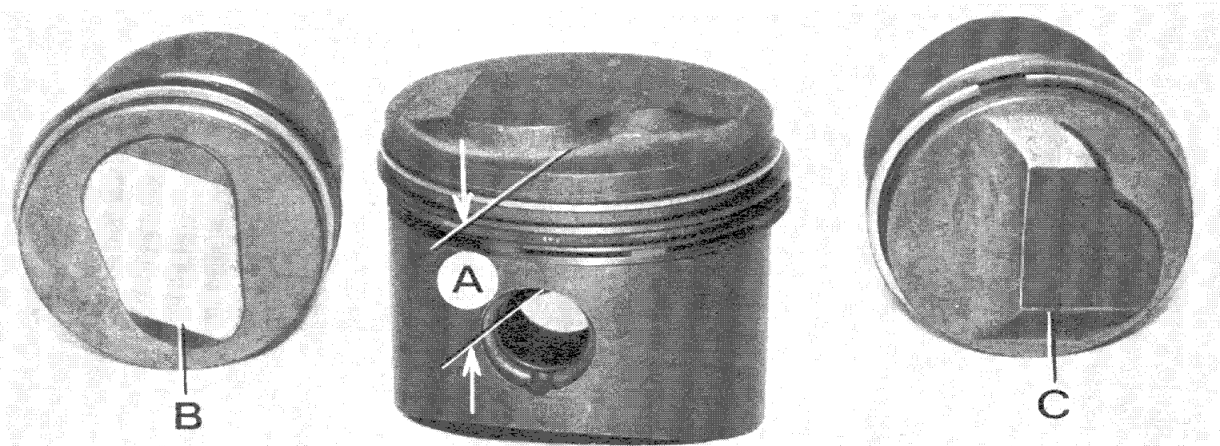

Piston identification:

Piston identification:

BMW 1502	A = 35.6 ± 0.15 mm (1.4016±0.0059 in)	ε = 8.0
1602	} A = 35.6 ± 0.15 mm (1.4016±0.0059 in)	ε = 8.6
1802		
2002	} A = 31.3 ± 0.15 mm (1.2323±0.0059 in)	ε = 8.3
2002 A		
2002 T1	} A = 31.5 ± 0.15 mm (1.2402±0.0059 in)	ε = 10.0
2002 tii		

Important: Note modification of combustion chamber of two-litre engines (hemispherical).

Modification marked on cylinder head E 12:

Important: Note modification of combustion chamber of two-litre engines (hemispherical).

Modification marked on cylinder head E 12:

BMW 2002	A = 31.1 ± 0.15 mm (1.2244±0.0059 in)	ε = 8.3
2002 tii	A = 31.1 ± 0.15 mm (1.2244±0.0059 in)	

The pistons are marked on the crown.

B = piston for normal combustion chamber

C = piston for hemispherical combustion chamber



Measure piston ring side play¹⁾.



Remove piston rings and check ring gap¹⁾.



Note when fitting: Fit piston rings with the word TOP faces the piston crown.

1 = rectangular ring

2 = cutaway ring

3 = oil scraper ring (equal chamfer)



¹⁾ See specifications

11 31 000 Removal and fitting of camshaft

Remove cylinder head – 11 12 100.
Unscrew clamp bolt and pull out distributor.

Note when fitting: Turn distributor rotor counterclockwise by approx. 3.5 cm (1 1/2 in) (A) from the notch in the distributor housing.
Bring distributor drive into mesh with camshaft drive.
Adjust ignition timing – 12 11 004.

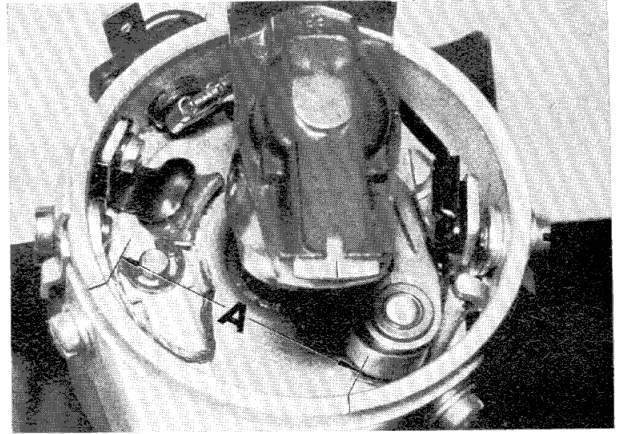

Note position of vacuum can relative to rocker cover.

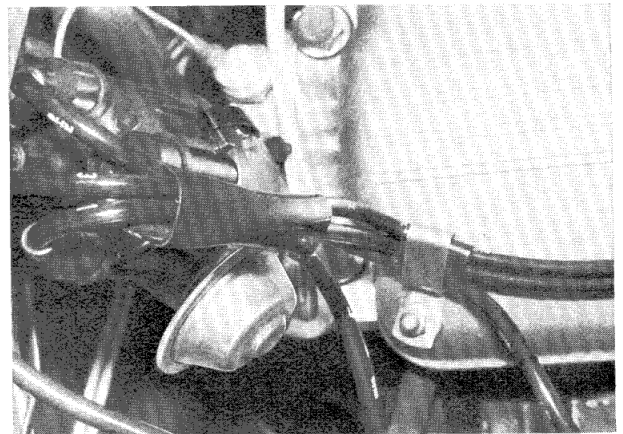

Fasten cylinder head to assembly tool 6025-1.
Remove oil pipe.

Note when fitting: Note position of sealing rings when assembled.

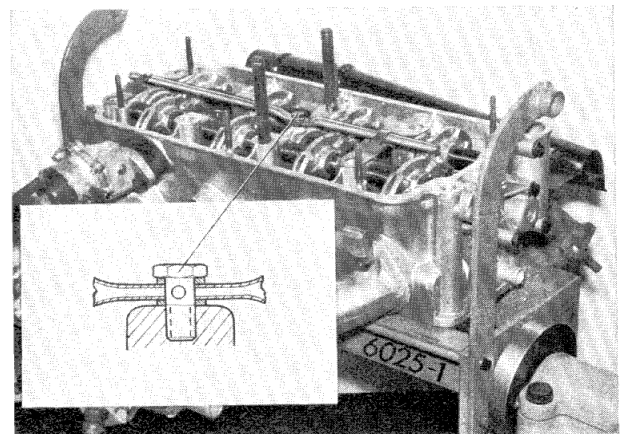

Remove fuel pump.

Note when fitting: Check gaskets and insulating flange and replace if necessary.
Pull tappets out slightly.

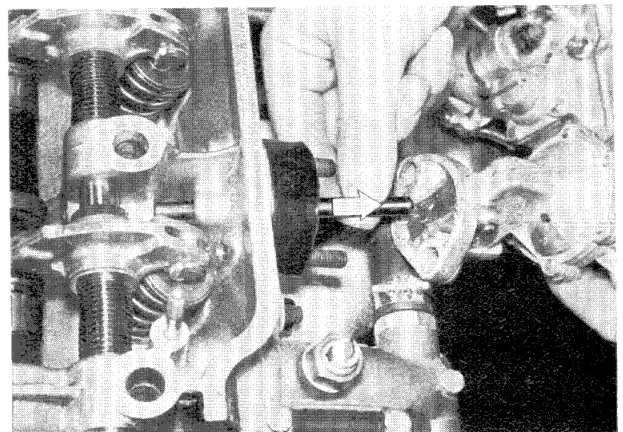

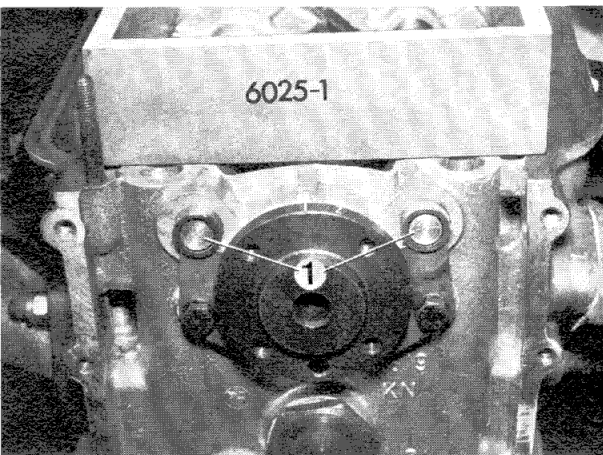

Set eccentric adjusters to maximum valve clearance. Fit pressure frames 6025-1 or 6025-2 on carburettor engine, and tension rockers.

Warning: on fuel injection engine, use only pressure frame 6025-2, or else the valve heads will be distorted. Renew loose end plugs (1) and insert with "Loctite" No. 270

Note when fitting: Adjust valve clearances.

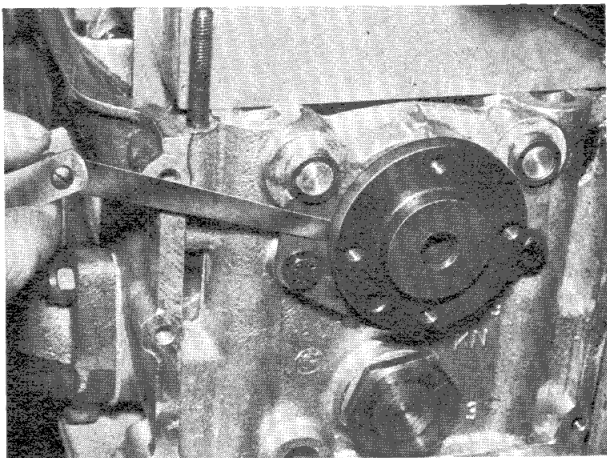

Check axial play¹⁾ between guide plate and camshaft.

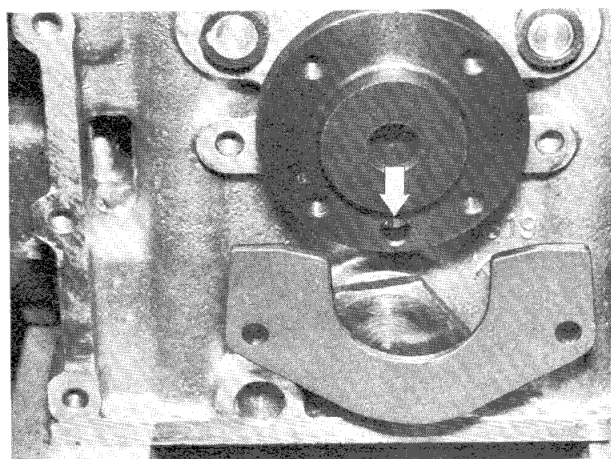

Remove guide plate.
Carefully pull out camshaft.

Note when fitting: After the guide plate has been fitted, it must be possible to turn the camshaft easily. Make sure that the notch in the flange is flush with the case projection in the cylinder head.

The hole for the dowel pin must face downwards.

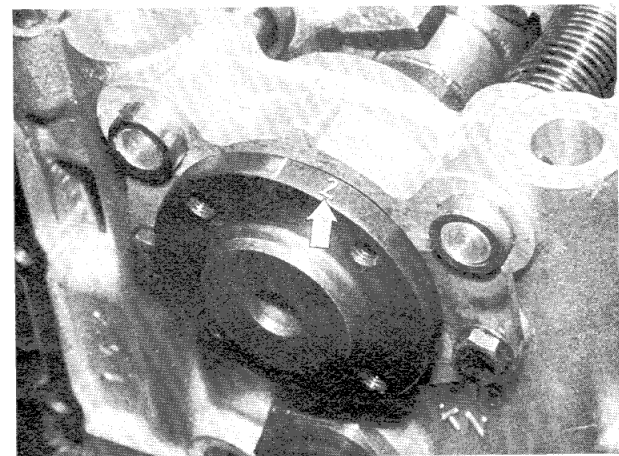

Camshaft designation:

- (2) 264⁰²) standard for BMW 1502 ÷ 2002 tii
- (3) 300⁰³) special equipment for 1602 ÷ 2002 T1
- (4) 324⁰³) special equipment for 1602 ÷ 2002 T1



¹⁾ See specifications

²⁾ previously 270⁰ up to chassis No. 908 500

³⁾ can only be fitted subsequently if bearing bore is enlarged to match.

11 31 051 Timing chain – renewing

The timing chain is pre-stretched and will not need to be renewed for at least 50 000 km (30 000 miles). If abnormal chain noise is heard, check the chain tensioner piston – 11 31 090.

Remove the distributor cap.

Set the piston in cylinder 1 to top dead center.

The distributor rotor will point to the notch in the distributor body. The pointer will be aligned with the second notch in the V-belt pulley, looking clockwise.

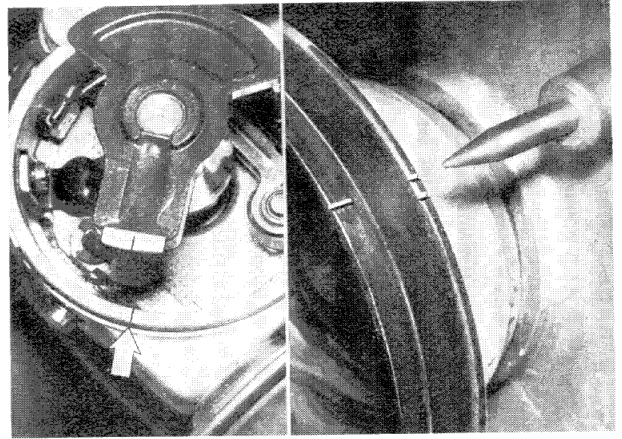

Remove the upper and lower timing case covers – 11 14 120.

Open up the keeper plates.

Detach the chain sprocket.

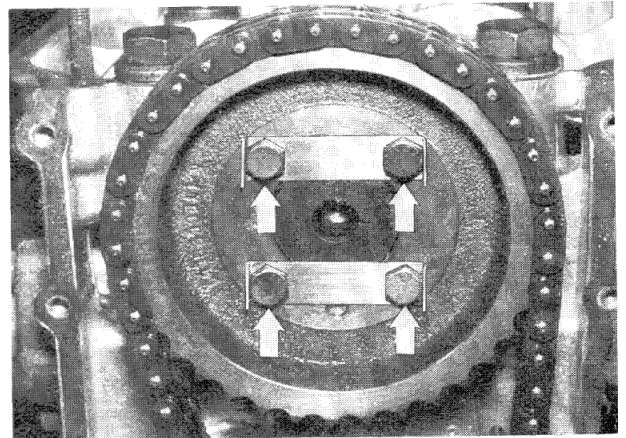

When installing: Install the chain so that the hole for the peg faces downwards. The notch in the camshaft flange must be aligned with the cast projection on the cylinder head.

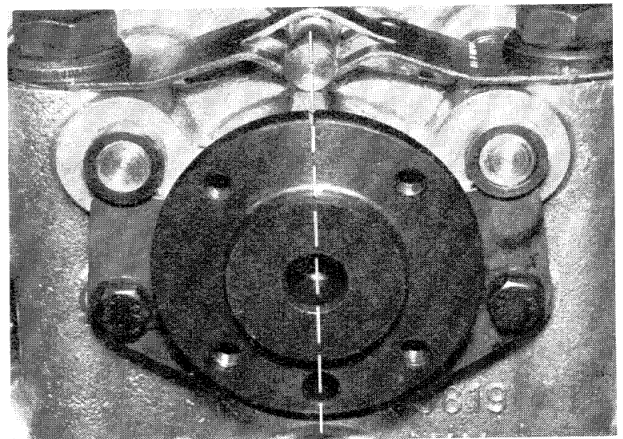

Extract the circlip (1).

Unscrew the pivot pin (2) until the slider rail is touching the cylinder head gasket.

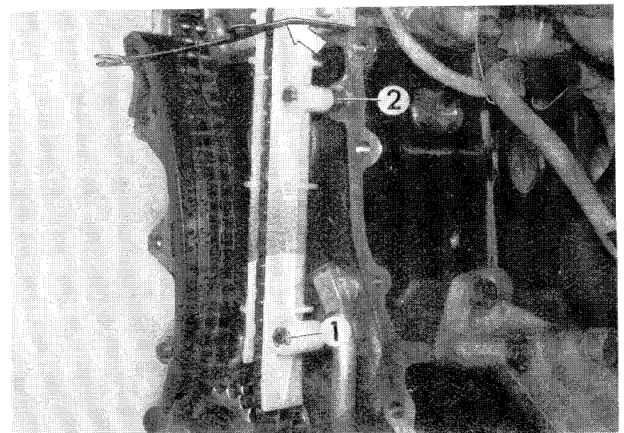

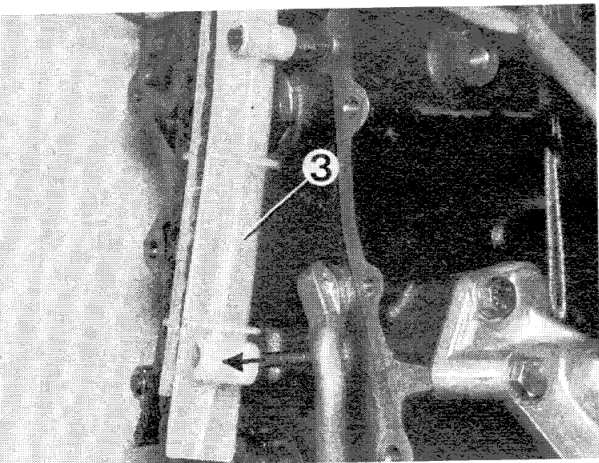

Detach the timing chain from the sprocket.
Pull the slider rail (3) out at the bottom, and swing to the right.

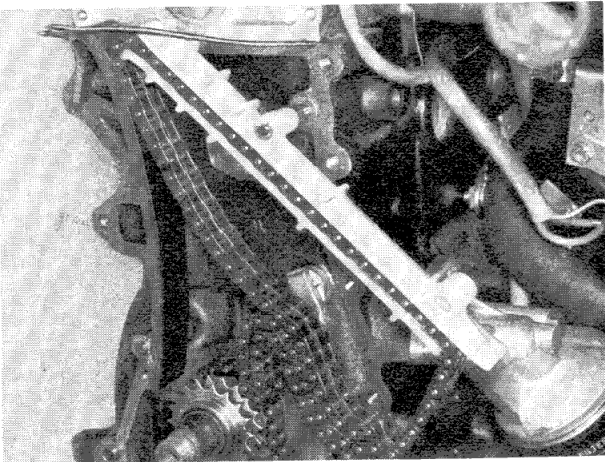

Remove the timing chain from the slider rail.
Check condition of chain sprockets and renew if necessary
- 11 31 061.

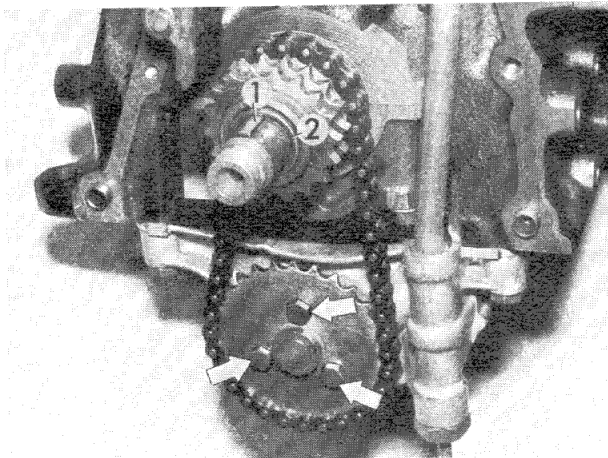

11 31 061 Chain sprockets – renewing

Remove the timing chain – 11 31 051.
Remove the oil sump – 11 13 000.
Detach the chain sprocket at the oil pump.
Remove the Woodruff key (1) and the O-ring (2).
Take off the chain.

When installing: The O-ring (2) can be omitted when assembling.

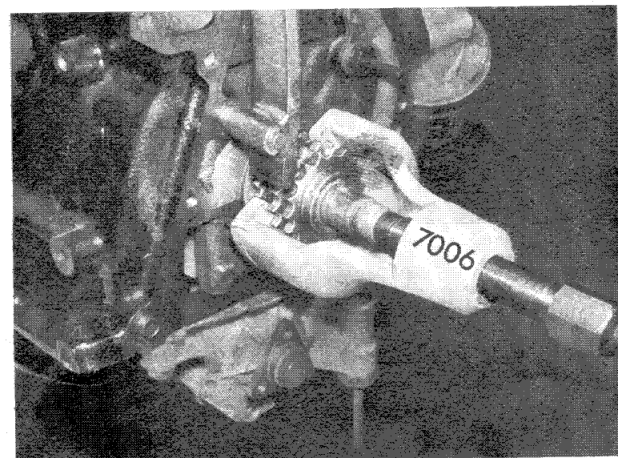

Detach chain sprocket with 7006 puller.

When installing: Heat the chain sprocket.



When installing: Chain tension is correct if the chain can be pressed in with light thumb pressure. Two lengths of chain are available in order to obtain the correct tension:
 Color codes: red = standard length
 green = extra-long

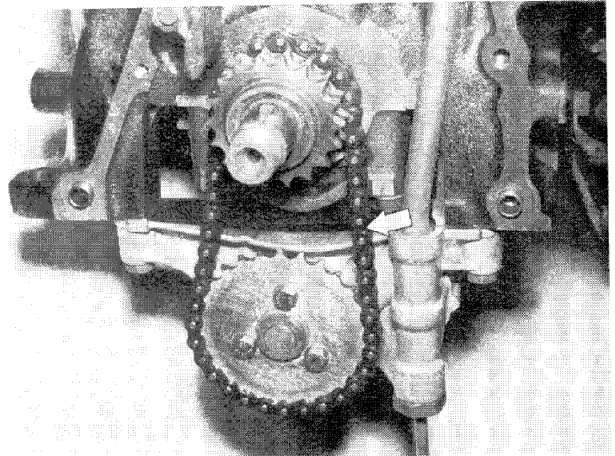

If neither chain permits correct tension to be achieved, shim plates of the correct thickness should be inserted.
Warning: Note correct position of oil hole in shim plate.

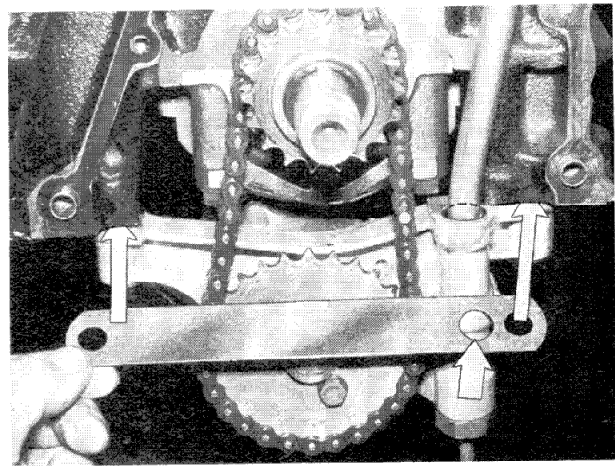

11 31 090 Chain tensioner piston – removing and installing

Unscrew and remove the screw plug.
Warning: Powerful spring pressure. Remove the spring and the piston.
When installing: The cutout in the piston engages with the end of the tensioner rail.

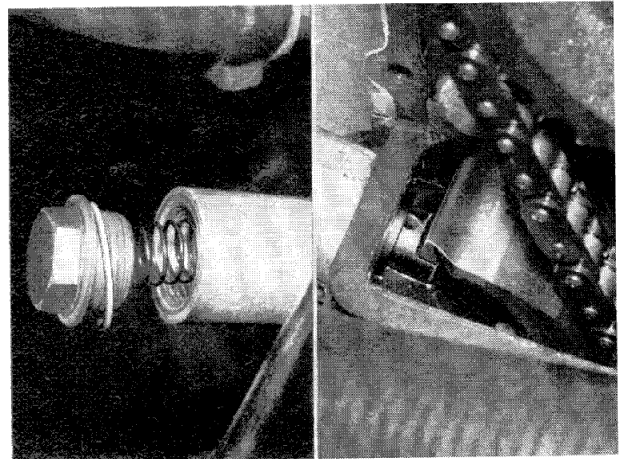

When installing: Check piston installed length A¹⁾ and spring length (relaxed) B. The taper-wound end of the spring faces the screw plug.

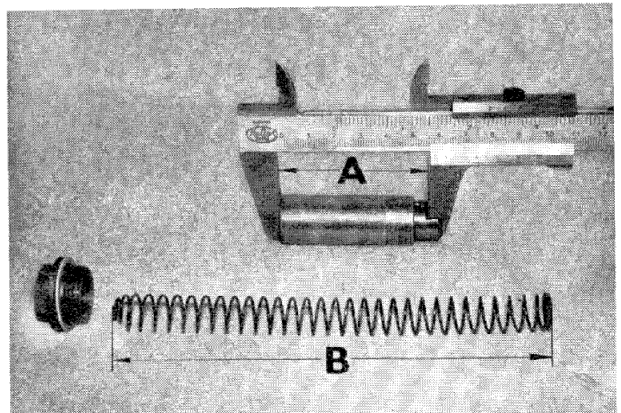

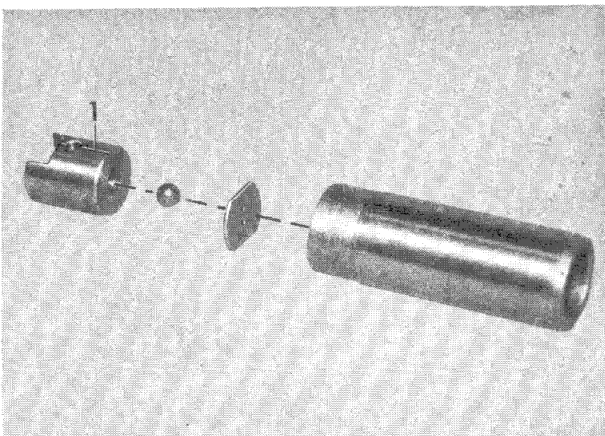

Check that vent slots (1) are not blocked with a compressed air nozzle.

If the vent slots are blocked, press out the valve.
Clean the vent slots.

When installing:

Do not cover the vent slots (1) with the perforated disc.

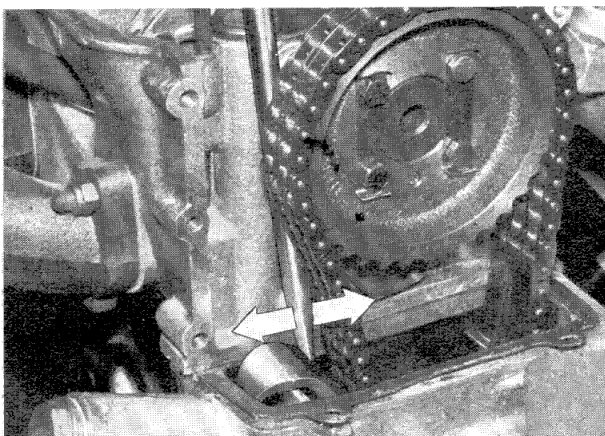

To bleed the piston, detach the rocker cover – 11 12 000.

Install the piston and spring.

Screw in the end plug but do not tighten.

Fill the oil cavity with engine oil.

Move the tensioner rail backwards and forwards with a screwdriver until oil emerges from the threads of the end plug.

If the chain runs noisily, the cause may be:

- a) Piston incompletely bled
- b) Piston seized
- c) Vent slots blocked
- d) Ball valve in piston not working
- e) Spring force too high or too low
- f) Piston installed length is incorrect
- g) Tensioner rail has no endplay on pivot pin.



11 31 581 Tensioner rail – renewing

Detach upper and lower timing case covers – 11 14 120.

Remove circlip (1).

Take off the tensioner rail.

When installing: The tensioner rail pivot should turn easily and a certain amount of endplay should be present.

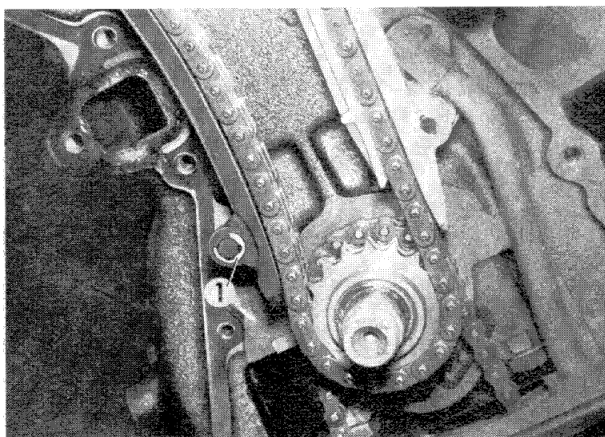

11 31 591 Slider rail – renewing

– Timing chain removed –

Take out the circlip (1) and remove the slider rail (2).

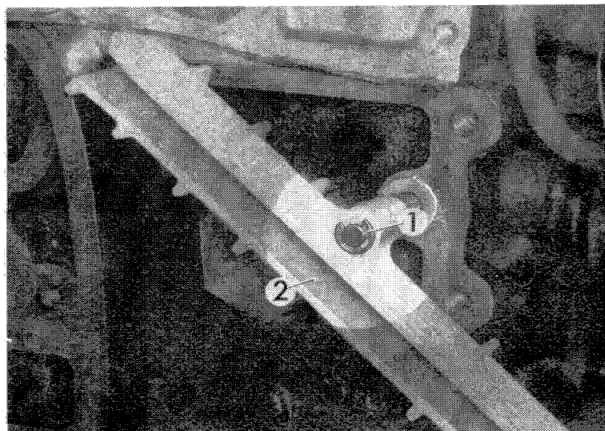

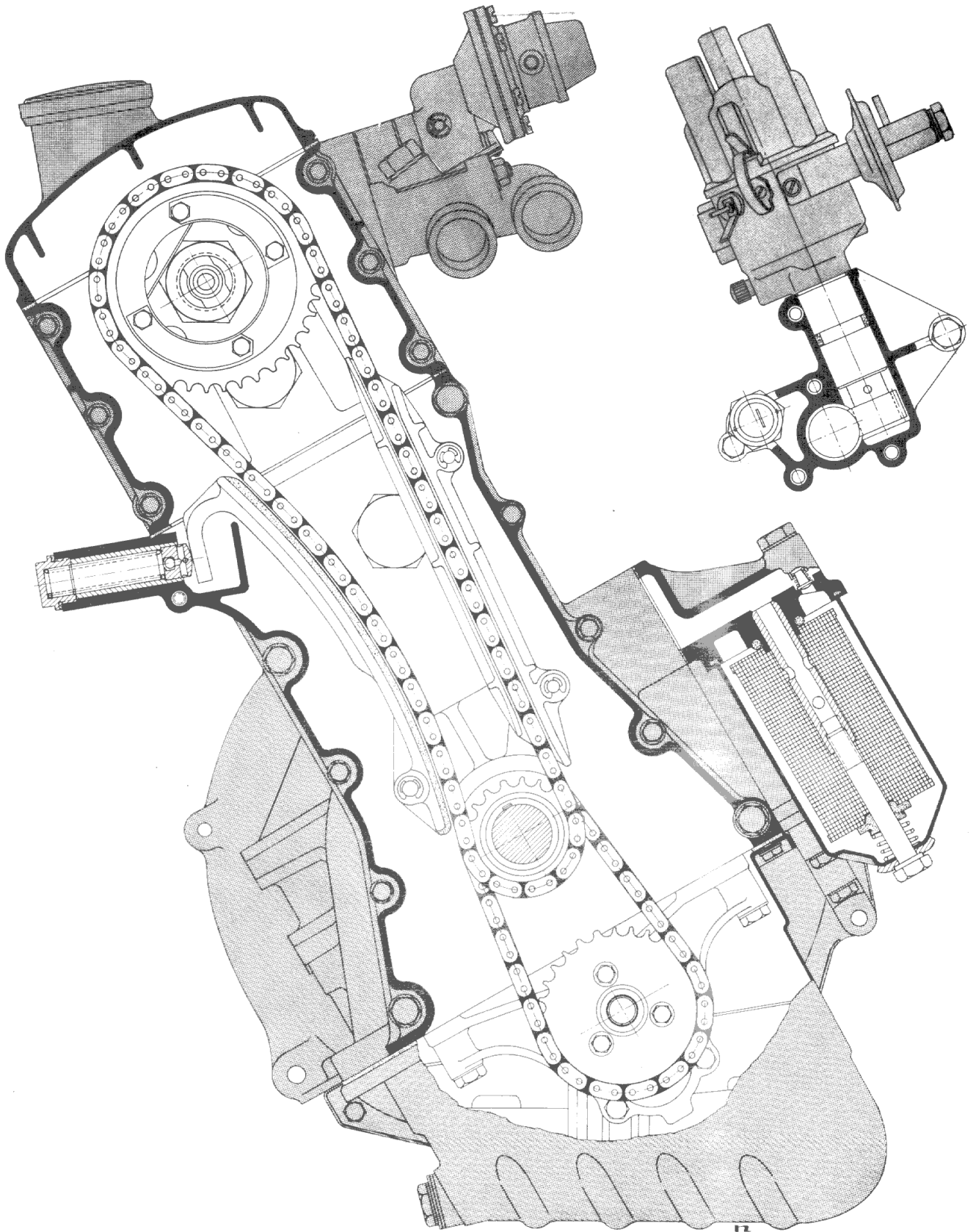

Timing chain and chain tensioner – general arrangement

11 33 020 Rocker shafts – removing and fitting

Remove camshaft – 11 31 000.
Push back thrust rings and rocker arms.
Lift out circlips (1).

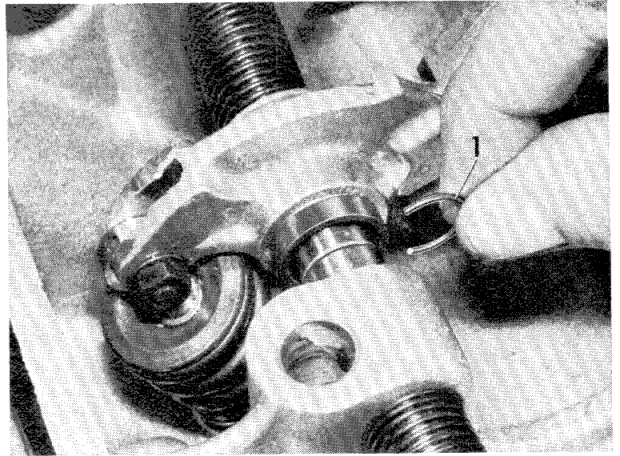

Remove distributor flange.
Fitting instruction: Note self-sealing washer (1).
Only use Cobritol gaskets (2).

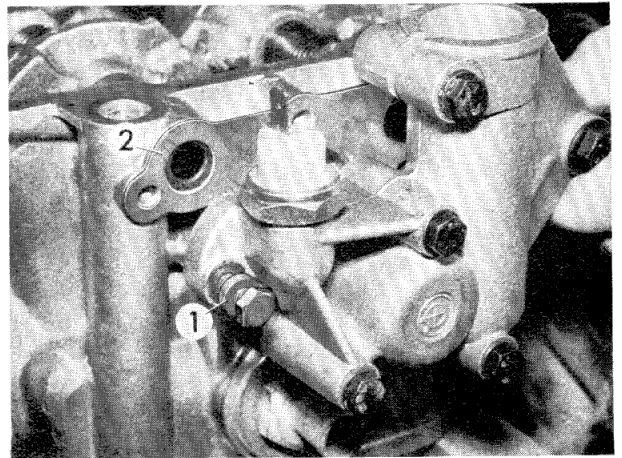

Drive out rocker shafts with punch 6012.
Fitting instruction: Renew worn or scored shafts.

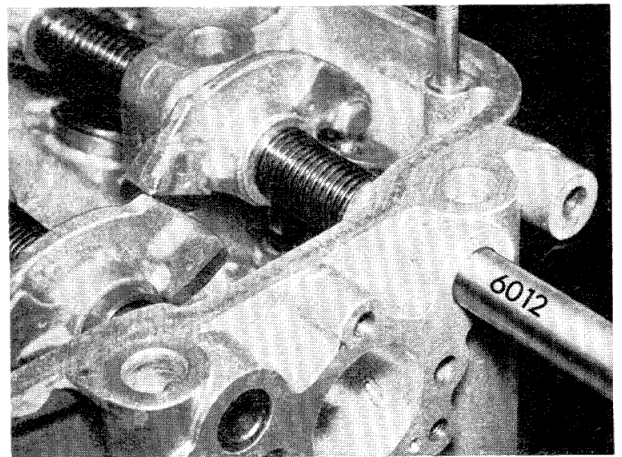

Installed position of individual parts:
Spring (3), washer (4), rocker (5), thrust ring (6).

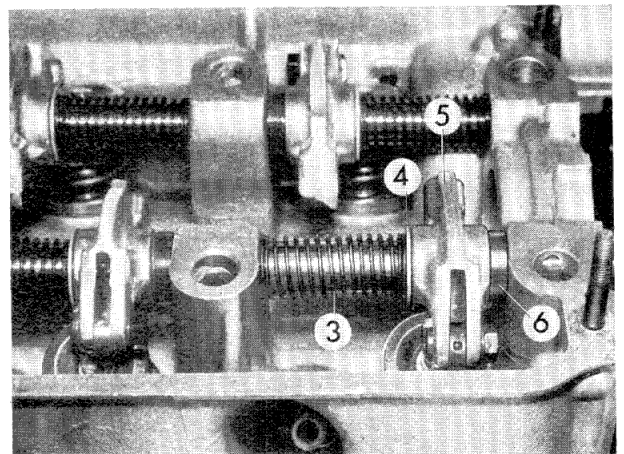

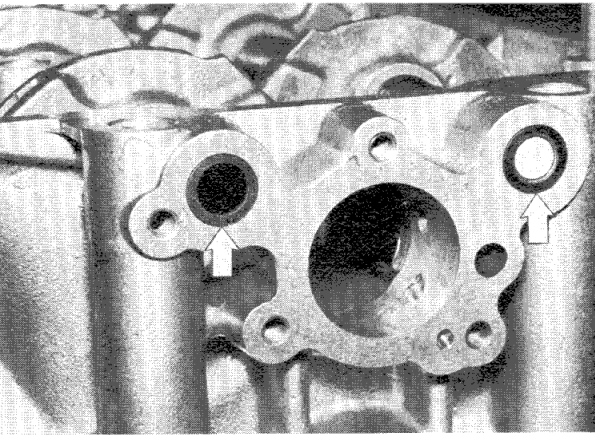

Note: The rocker shaft on the inlet side is open at the rear. The rocker shaft on the exhaust side must be closed; if necessary, close with plug.

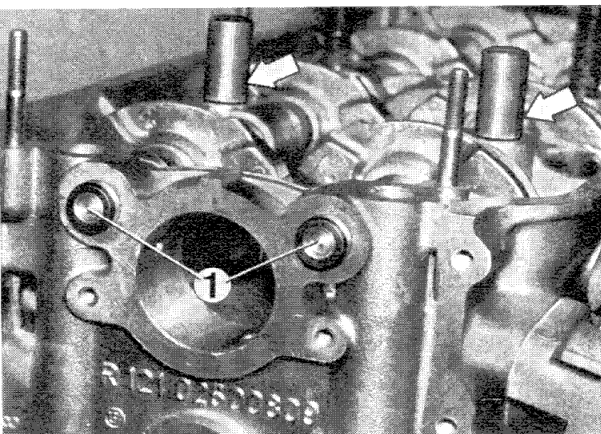

Warning: Renew loose plugs (1) and insert using Loctite No. 270.

Fitting instruction: Align rocker shafts so that the cylinder head bolts fit into the recesses. Insert locating pins.

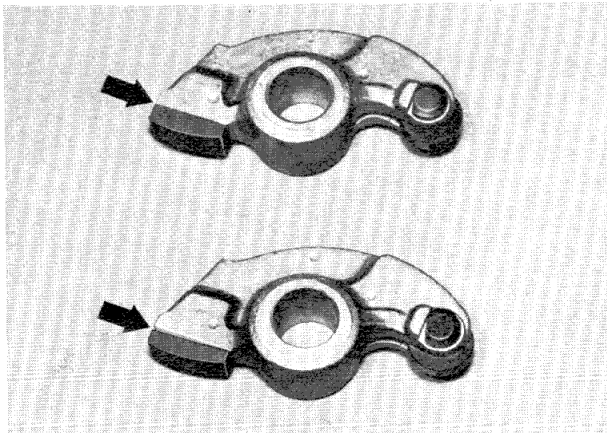

Note: Renew rocker arms with loose follower pads. Very loud valve noise is the result of loose pads.

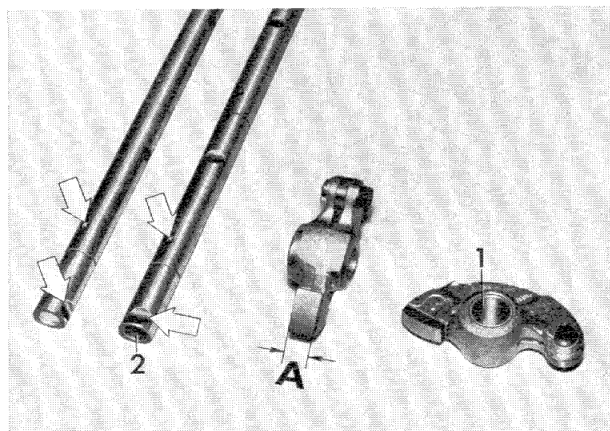

Note: New design of rockers and rocker shafts.

Previously: Rocker without bushing
Pad width (A = 12 mm = 0.472 in)
Oil drillway in rocker shaft downwards.

New design: Rocker with bushing
Pad width (A = 11 mm = 0.433 in)
Two horizontal oil drillways in rocker shaft (2).



11 34 004 Valve clearances – adjustment

Remove cover 11 12 000.

To facilitate adjustment of valve clearance, turn engine with device 7008-1.

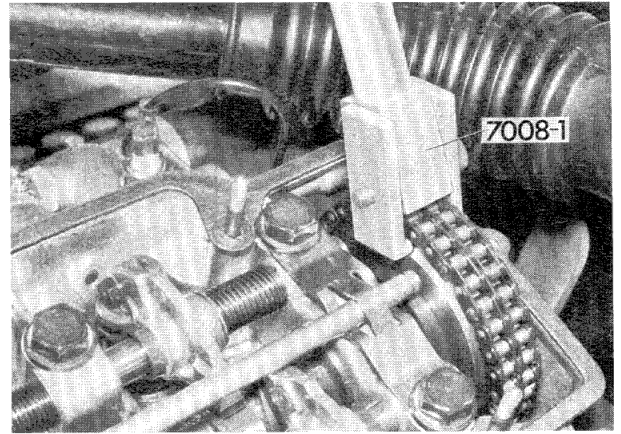

The adjustment sequence¹⁾ corresponds to the firing order 1–3–4 at top dead centre on compression. Adjust valve clearance¹⁾ after slackening nut (1), between valve and eccentric.

Warning: Valve clearance must under no circumstances be measured or adjusted between rocker pad and cam.

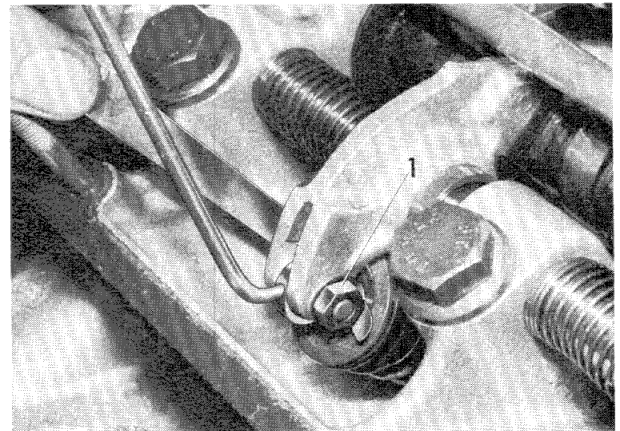

11 34 509 Checking all valves for gastightness – Camshaft removed –

The spark plugs must be installed.

Fill the combustion chamber with petrol (gasoline). If it leaks out through the valve seats, the valves must be reground.

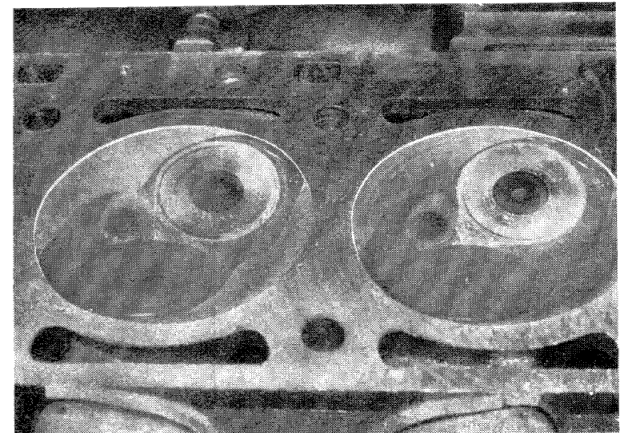

11 34 550 Valves – removing and fitting – Rocker shafts removed –

Place wooden underlay in assembly device 6025-1. Install the cylinder head.

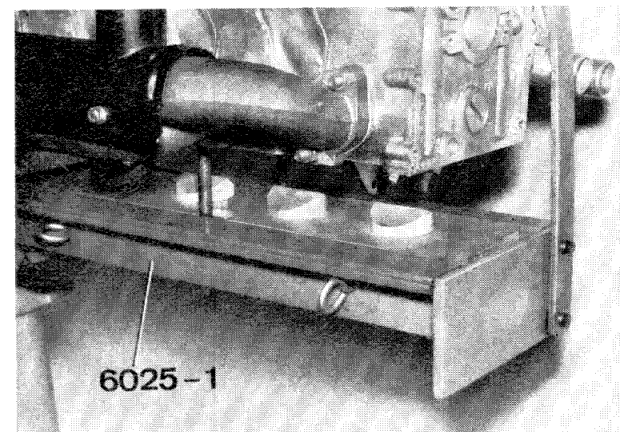

¹⁾ See specifications

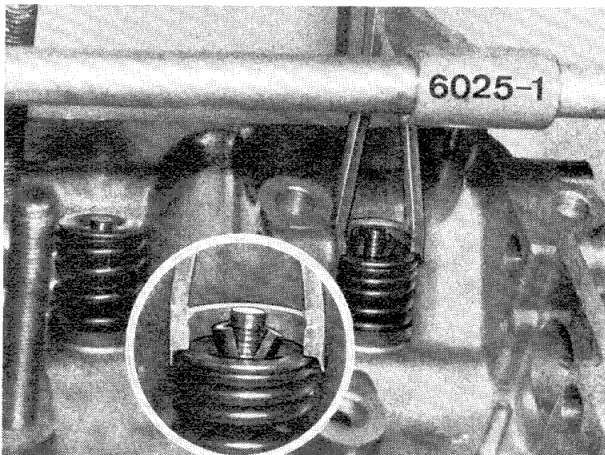

Press down valve spring with 6025-1 device, and remove valve collets.

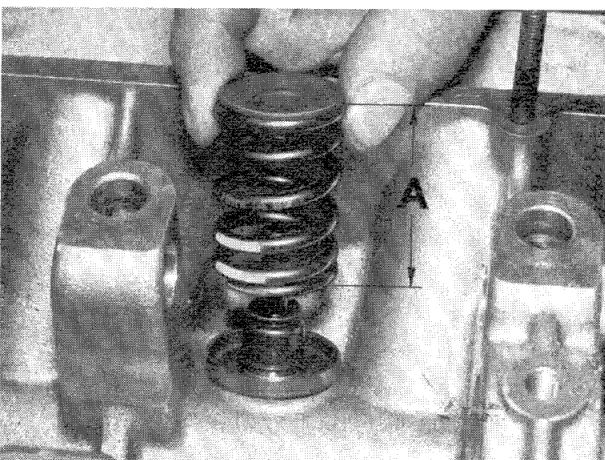

Take out spring cap and spring.

Fitting instruction: Fit only springs coded green. Measure free length A¹⁾.

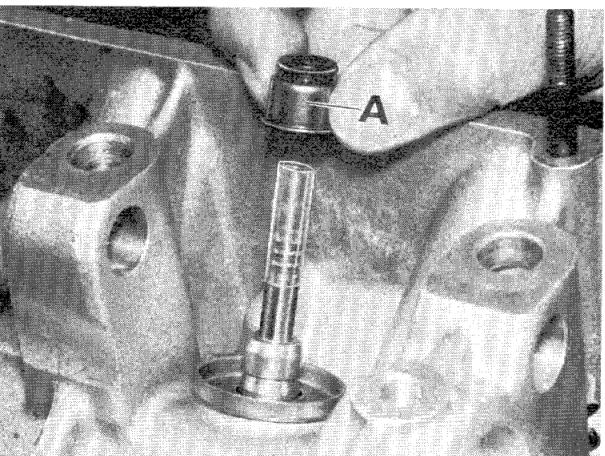

Deburr valve stem in order to avoid damage to the valve stem seal and valve guide, renew damaged valve stem seals (A) as oil consumption will otherwise be excessive.

Fitting instruction: Before fitting the valve stem cap, wrap the ring grooves with transparent adhesive tape.



11 41 000 Oil pump – removing and fitting

Remove oil sump – 11 13 000.
Detach chain sprocket.
Open keeper plates.
Detach oil pump from holder.

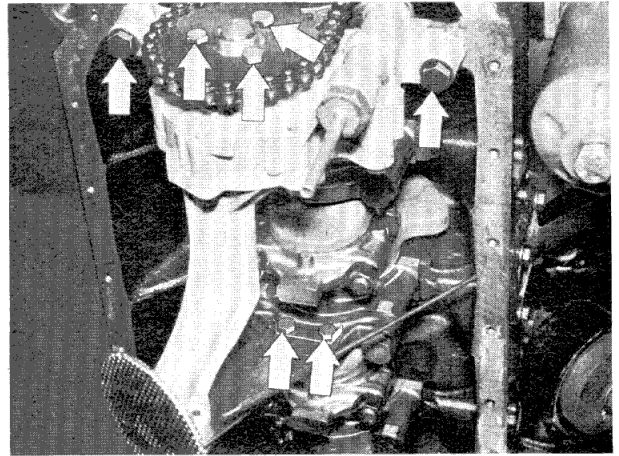

Remove oil pump.
Note: Pay attention to fitted position of O-ring in housing and pressure relief pipe.

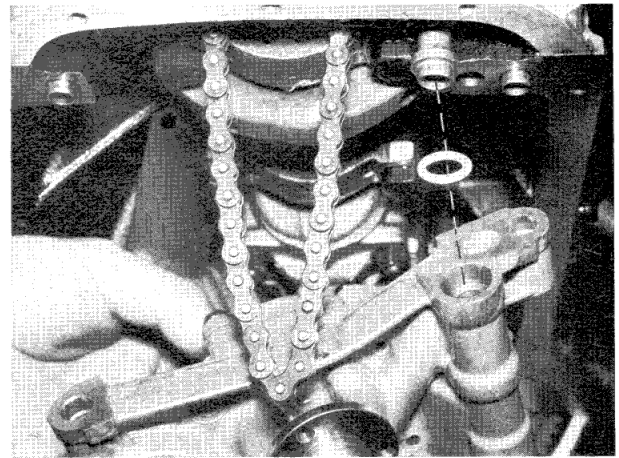

Fitting instruction: Adjust chain tension with shim washers (1) so that the chain can be depressed with light thumb pressure.
Note: In the case of shim washers (1) with oil bores, note correct fitted position.

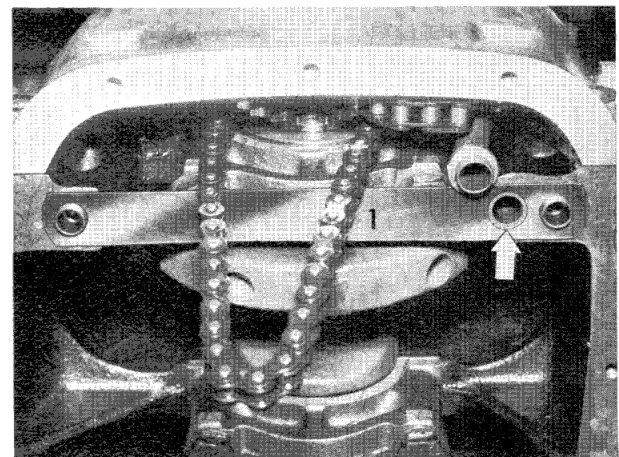

Fitting instruction: Slacken retaining plate on oil pump, align and tighten in a position free from stresses.

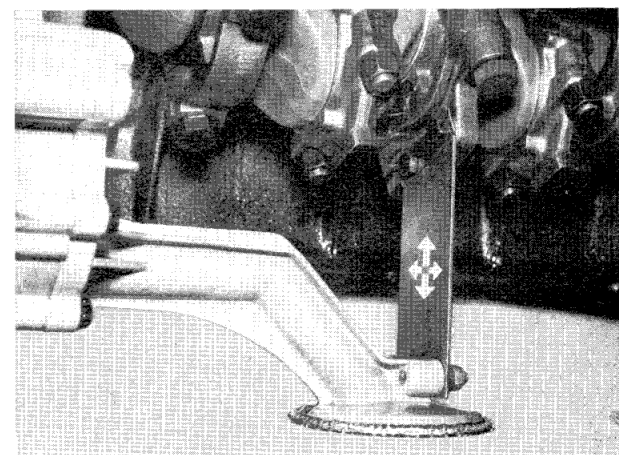

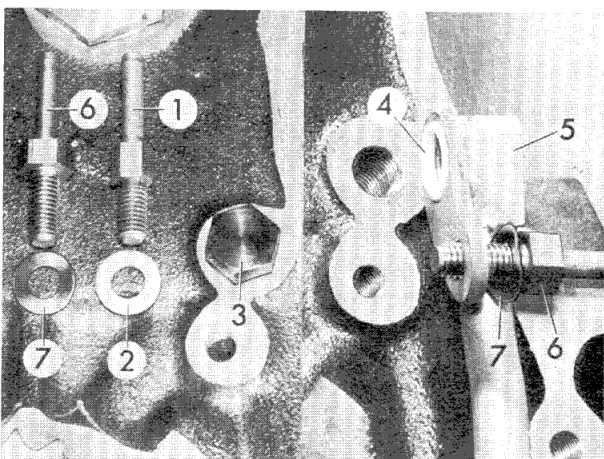

Subsequent installation of rotor type oil pump

Remove gear type oil pump, pivot pin (1), washer (2) and screw plug (3).

Fitting instruction: Insert sealing ring (4).

Secure pipe (5) with new pivot pin (6) and corrugated washer (7).

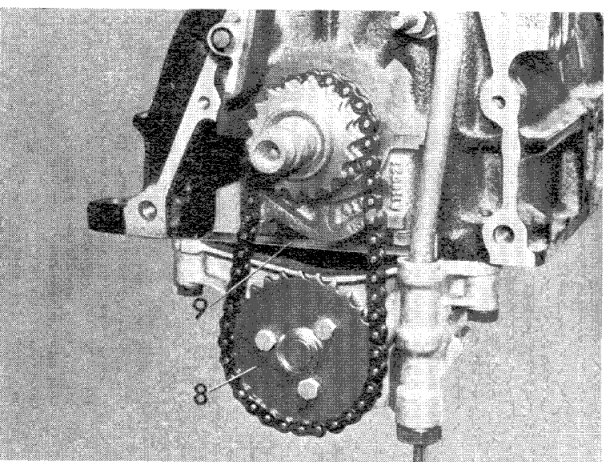

Fit rotor type oil pump with sprocket (8) and 46 link chain.

Fitting instruction: Adjust chain tension so that the chain can be depressed with light thumb pressure. Two chains are available for this purpose.

Colour coding: red-standard length
green-oversize

If the chain tension cannot be adjusted correctly with either of these chains, shim washers (9) of appropriate thickness should be used.

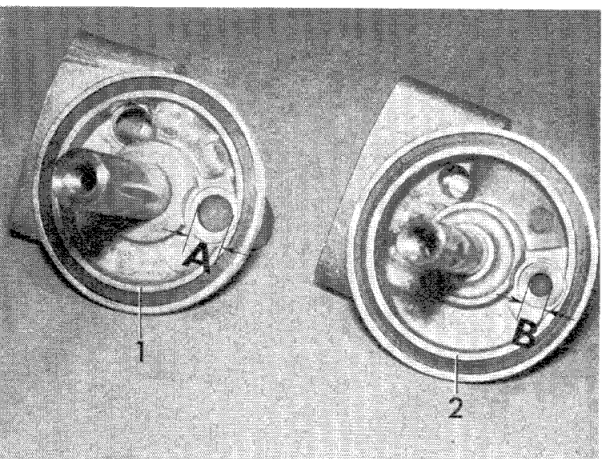

Note: Pressure relief valve has a different opening pressure.

It is essential to change the upper section of the oil filter.
Oil filter upper section 1: Rotor type oil pump A 12 mm (0.47 in)

Oil filter upper section 2: Gear type oil pump B 7 mm (0.28 in)

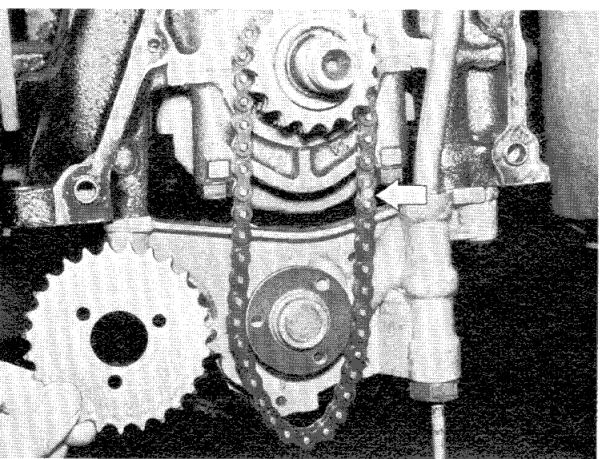

11 41 151 Roller chain for oil pump drive – renewing

Remove oil sump – 11 13 000.

Remove timing chain – 11 31 550.

Remove oil pump chain sprocket.

Remove roller chain.

Fitting instruction: Adjust chain tension; see removal of oil pump – 11 41 000.



11 41 512 Disassembly and assembly of oil pump

Unscrew bolt (1).

Take out pressure spring (2) and piston (3).

Important: Do not change length of spring¹⁾ when free of tension. Remove oil pump cover (4).

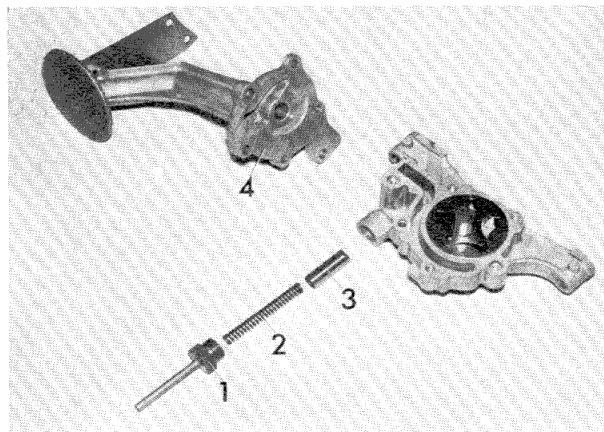

Check play¹⁾ between outer rotor and pump housing.
If the maximum play limit is exceeded, replace pump housing.

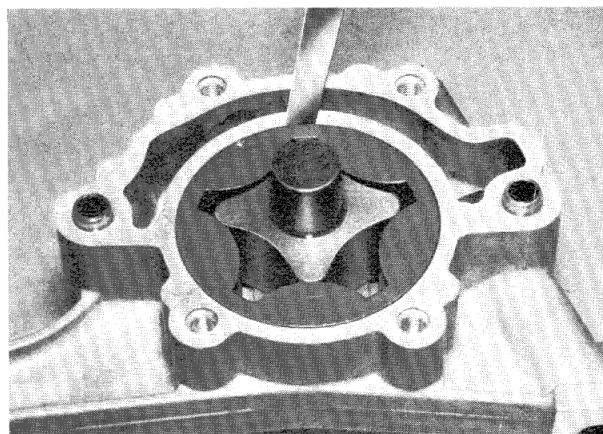

Check clearance¹⁾ between the inner and outer rotors.
If the maximum clearance limit is exceeded, replace inner and outer rotors.

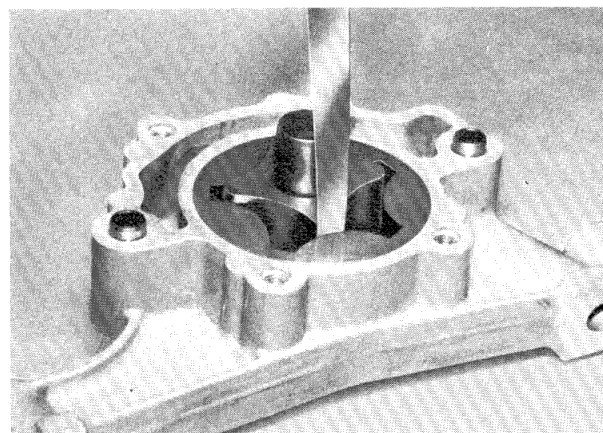

Check play¹⁾ between rotor sealing surface and pump housing.
If the maximum play limit exceeded, replace pump housing.

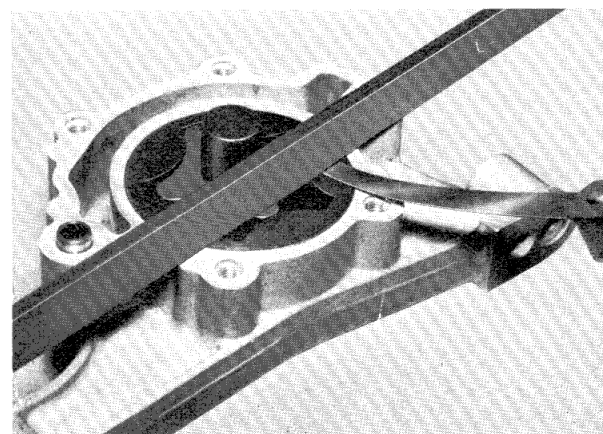

¹⁾ see Specifications
10.73 Alteration

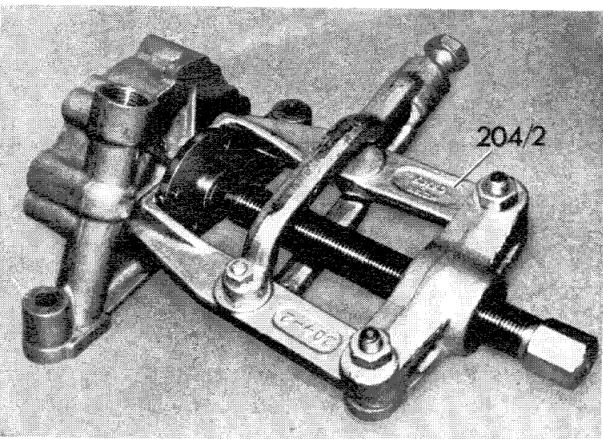

Using Kukko 204/2, pull off hub. Do not press off.

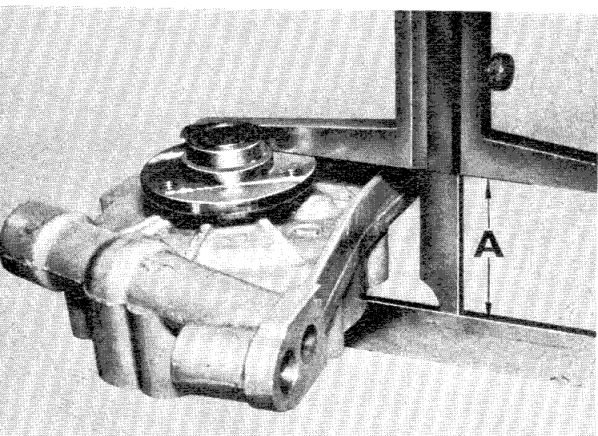

Note when fitting: Note correct clearance between hub and inner rotor:

$A = 42.7 \pm 0.1 \text{ mm} (1.6811 \pm 0.0039\text{'})$.



11 42 020 Full-flow oil filter

Model A: Full-flow oil filter made by Messrs. Purolator One excess-pressure valve, non-removable

Model B: Full-flow oil filter made by Messrs. Mann & Hummel One excess-pressure valve, removable

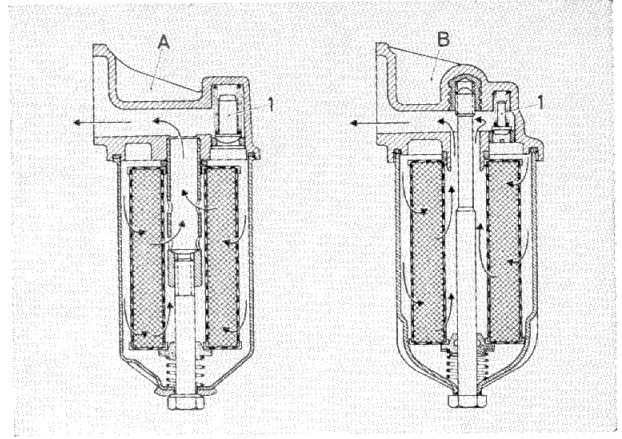

Important: Note hole drilled in upper section of oil filter:

1 = rotor oil pump A: 12 mm (0.4724")

2 = geared oil pump B: 7 mm (0.2756")

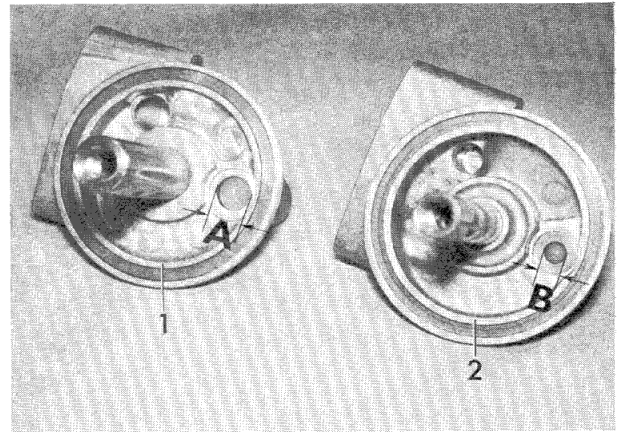

If the oil filter with throw-away cartridge is used, the excess-pressure valve is to be found in the cartridge.

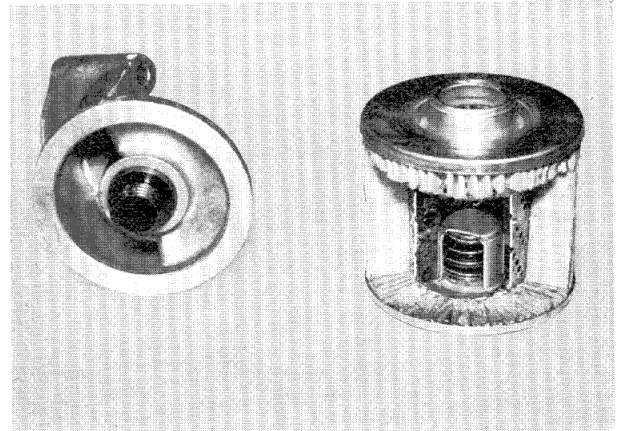

Using tool 6065/1, screw out filter with throw-away cartridge.

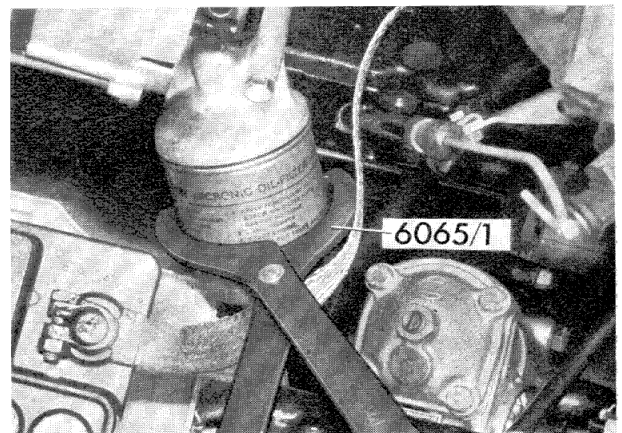

11 51 000 Removal and fitting of water pump

Removal of cooling fan cf. 11 51 000.
Loosen alternator.
Remove pulley and V-belt.

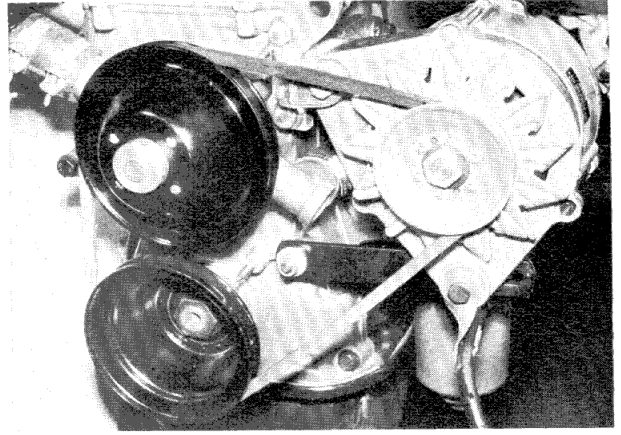

Loosen hose clamps.
Remove water pump.

Note when fitting: Replace seal and copper rings.
Clean sealing surface and apply a coat of grease on the seal.

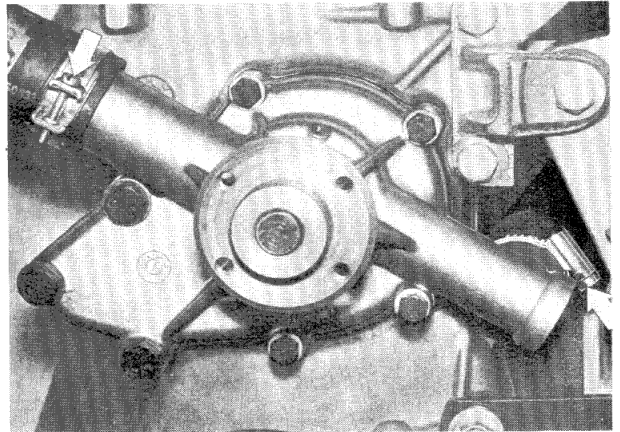

11 51 502 Disassembly and assembly of water pump

Using Kukko 204/2, pull off hub.

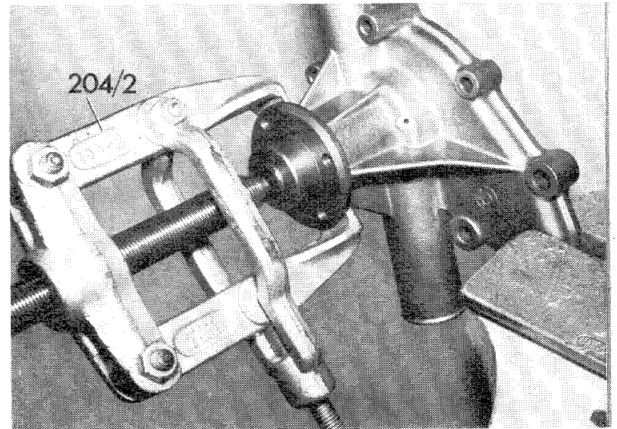

Note when fitting: Distance A must measure 75.3 ± 0.2 mm (2.9646 ± 0.0079 ”).

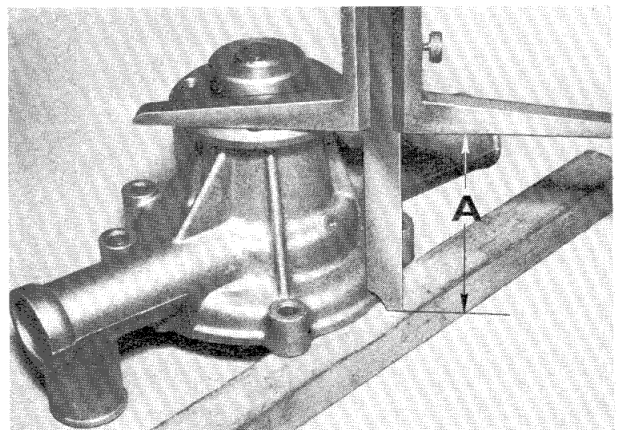

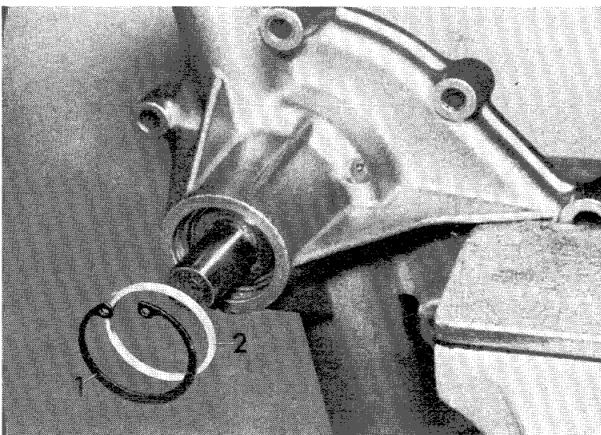

Take out safety ring (1) and spacer ring (2).

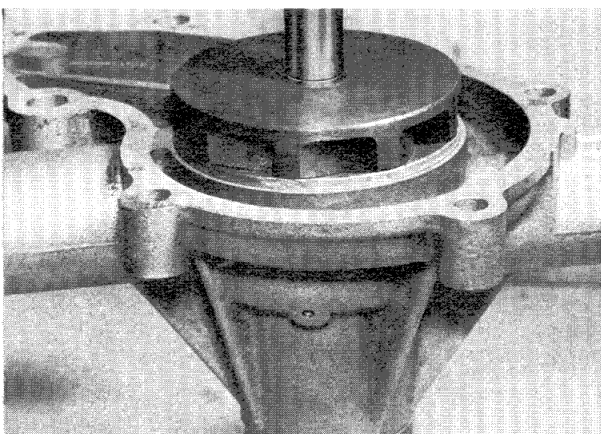

Press impeller out of housing, working from the shaft and water pump bearing.

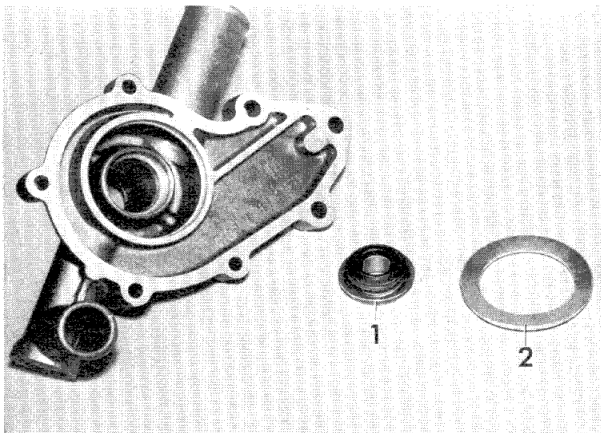

Force out slide sealing ring (1).
Remove cover ring (2).

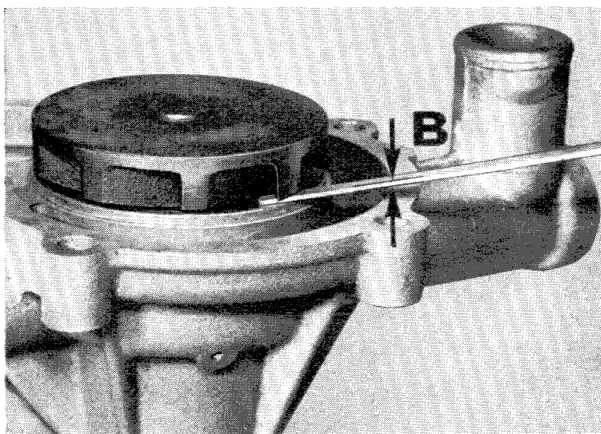

Note when fitting: Using Loctite AVV, force impeller into position.

Always maintain distance $B = 1 + 0.2 \text{ mm}$
($0.0394 + 0.0079''$).

Pressure required for forcing on impeller:
approx. 440 kp (approx. 500 kp for new impeller).



11 52 000 Fan — removing and fitting

Remove radiator. 17 11 000.

Open locking plates.

Remove fan.

A = 3000 mm (11.811").

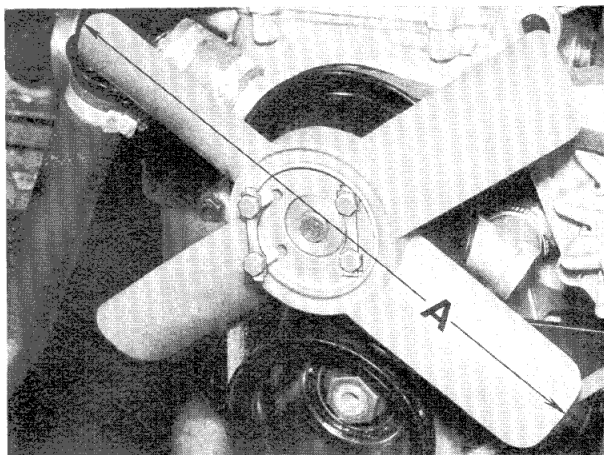

On vehicles which are used principally in town traffic (driving schools etc.) the 300 mm (11.811") dia. fan (four blades) can be changed over to a 360 mm (14.173") dia. fan (five blades).

The fan for USA vehicles has a diameter of 400 mm (15.748") and five blades.

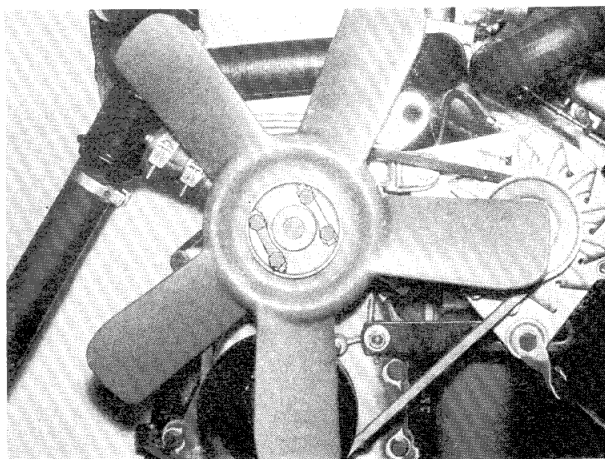

11 53 000 Removal and fitting coolant thermostat

Drain coolant.

Unfasten hose clamps. Take out thermostat.

Thermostat begins to open¹⁾ at: 80° C (176° F)

Note when fitting: Bleed coolant system.

Before refilling the coolant system set heater lever to „warm“. Fill in water and screw on cap until the second stop is reached. Run engine so that coolant is heated to 80° C (176° F). After the thermostat has opened, bleed system by turning radiator cap to first stop. In this process, press the upper and lower hose manifolds together by hand a few times, as this generates a pumping effect and ensures that any air still in the system can escape through the radiator.

Check coolant level and turn radiator cap to second stop.

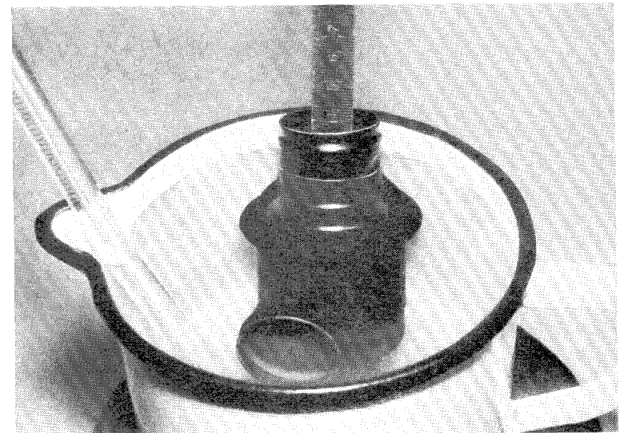
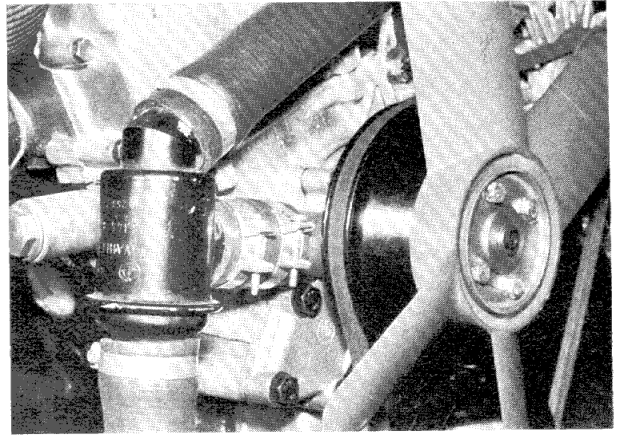

Check thermostat:

Place thermostat in water and heat water.

Using a steel measuring gauge, check when thermostat starts to open¹⁾ and determine aperture size. Aperture size should be 8 ± 1 mm (0.3150 ± 0.0394 “).

11 53 050 Removal and fitting of branch stub

Drain coolant.

Note when fitting: Bleed coolant system cf. 11 53 000.

Remove water hoses.

Pull cable off remote thermometer switch.

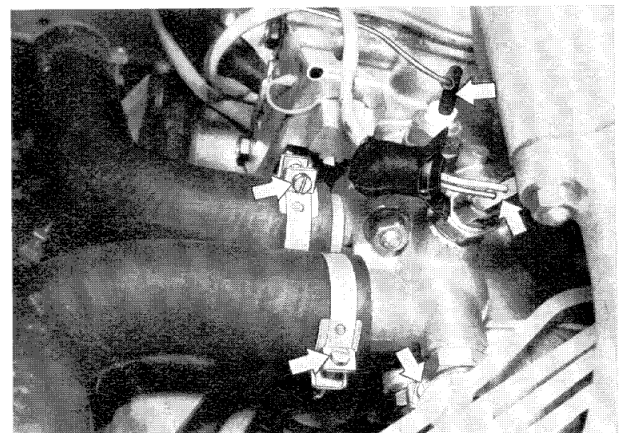
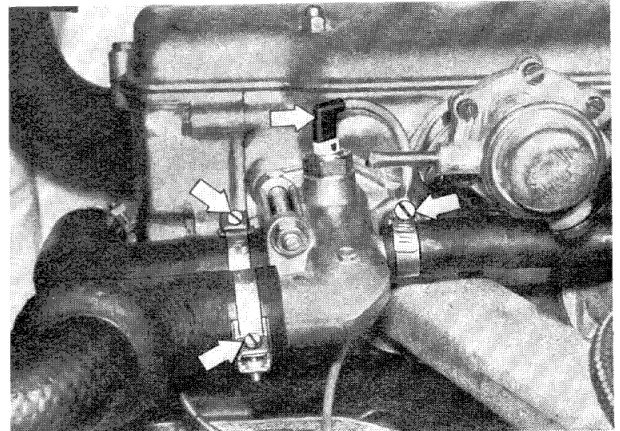

For injection engine:

Detach water hoses.

Pull cable off remote thermometer switch and temperature switch.

¹⁾ see Specifications

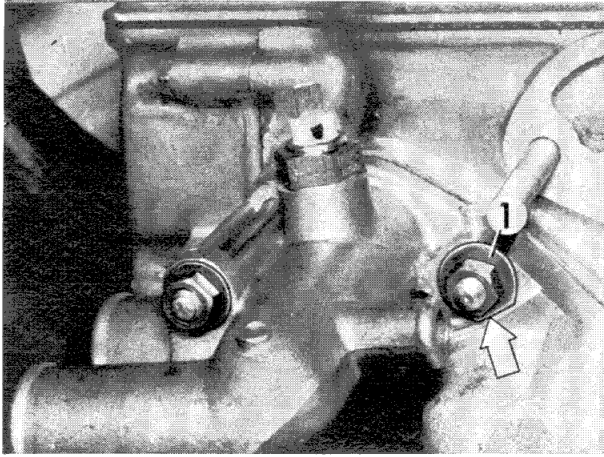

Remove branch stub from cylinder head.

Important: Make sure that the chamfered edge of disc (1) faces towards the milled edge of the intake pipe.

When replacing seal, remove intake pipe cf. 11 61 000.

On tii, remove intake manifolds cf. 11 61 290.

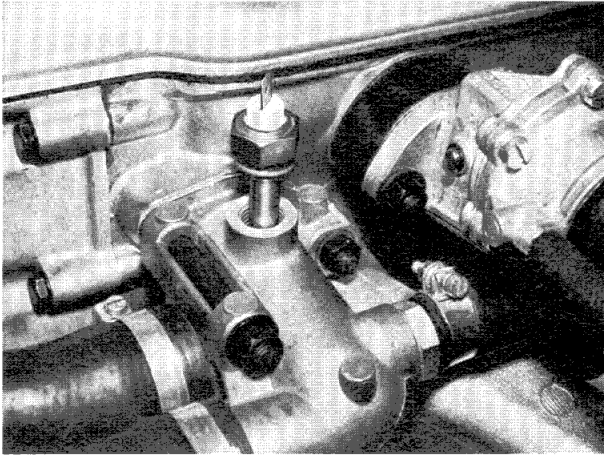

11 53 081 Replacement of remote thermometer switch

Drain some of coolant.

Pull off cable.

Unscrew switch from branch stub.

Note when fitting: Check seal and replace if necessary.

Bleeding of coolant system cf. 11 53 000.

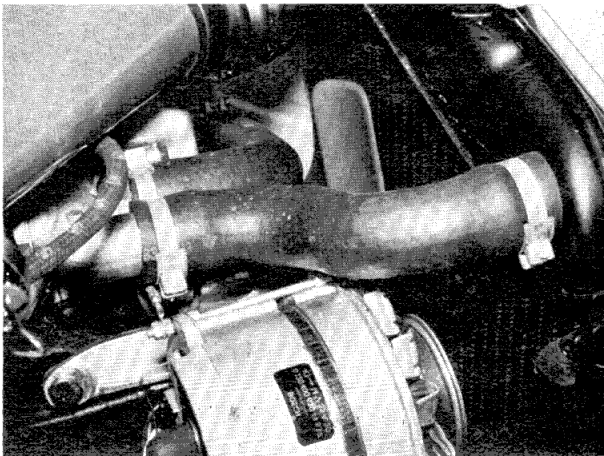

11 53 321 Replacement of all coolant hoses

Drain coolant.

Note when fitting: Bleeding of coolant system cf. 11 53 000.

Remove manifold between radiator and branch stub and refit afterwards.

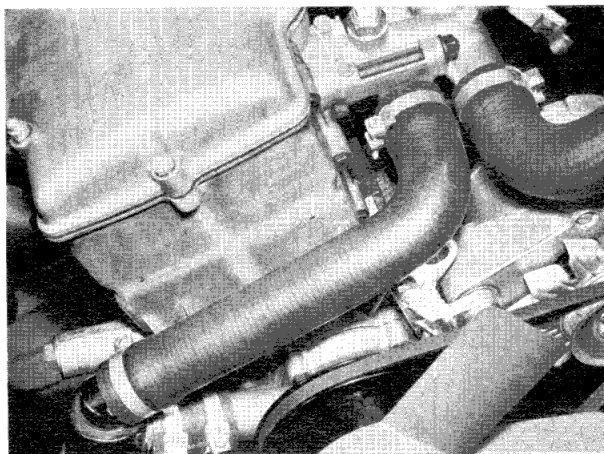

Remove short-circuit wire between branch stub and thermostat and refit afterwards.



Remove manifold between thermostat and radiator and refit afterwards.

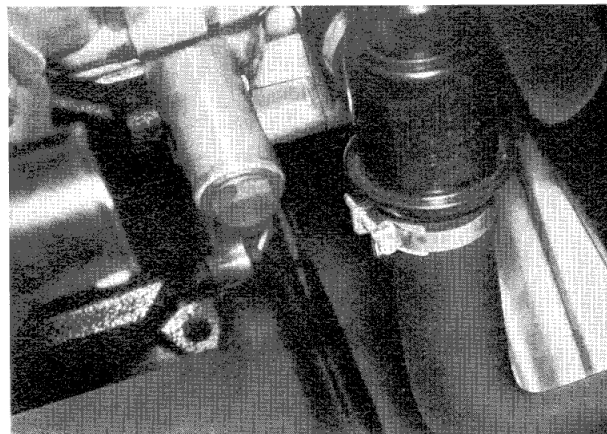

Disconnect short-circuit wire from thermostat.
Remove manifold between thermostat and water pump and refit afterwards.

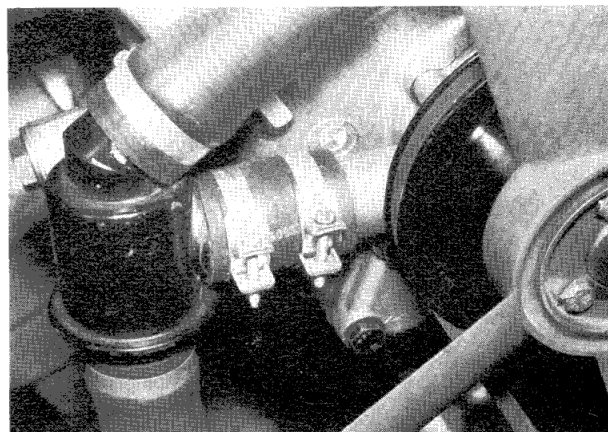

Remove manifold between branch stub and intake pipe and refit afterwards.

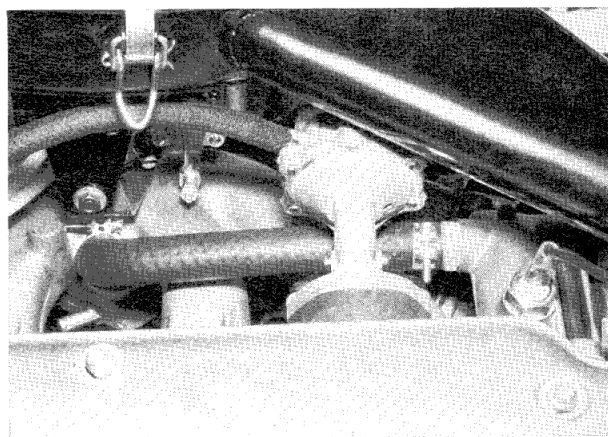

Remove hose between water pump and intake pipe and refit afterwards.

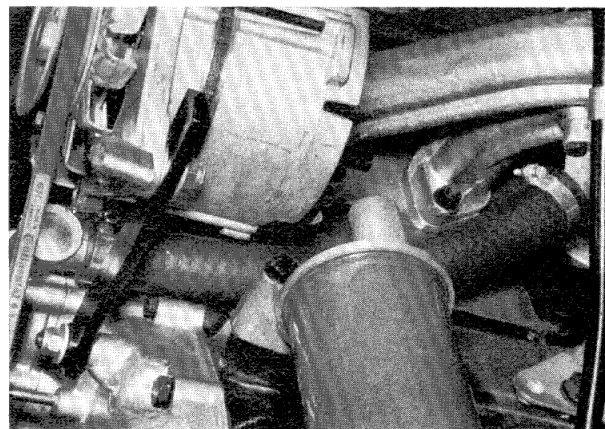

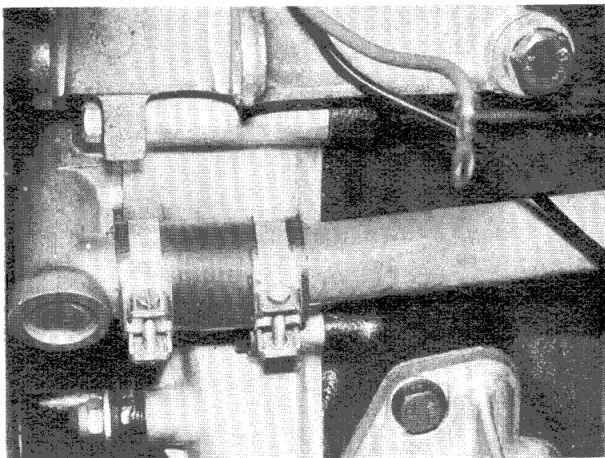

Applicable to 2002 TI:

Removal to alternator cf. 12 31 020.

Remove manifold between water pump and reflow pipe and refit afterwards. Disconnect hose clamps and press manifold onto reflow pipe. Push reflow pipe to the side and remove manifold.

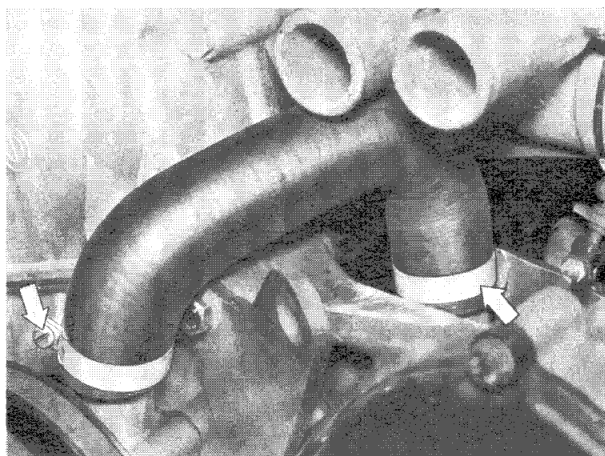

Applicable to the injection engine:

Remove hoses from branch stub.

Remove manifold between water pump and reflow pipe and refit afterwards.

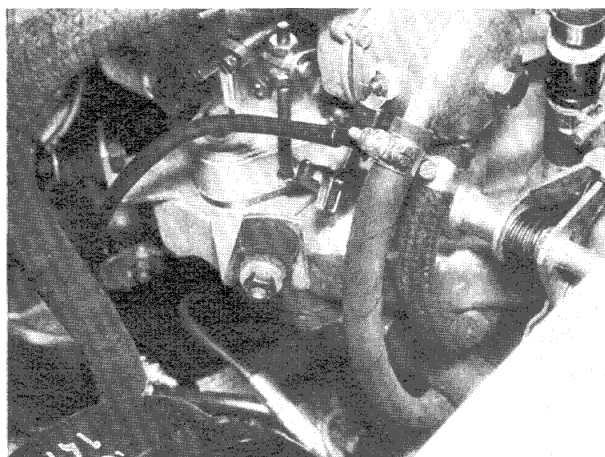

Applicable to 2002 A:

Disconnect feed and discharge hoses from choke caburettor.

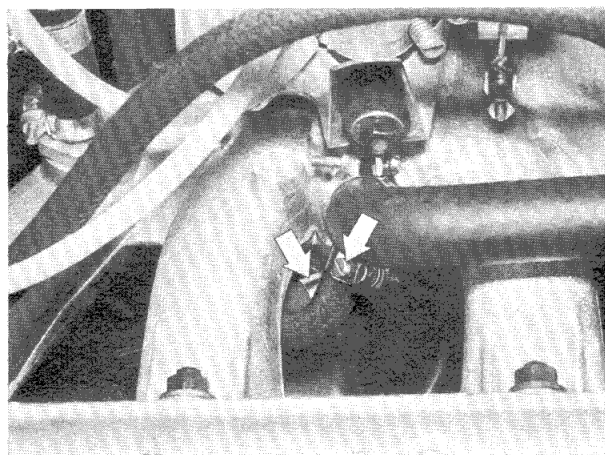

Disconnect feed and discharge hoses from intake pipe.



Applicable to injection engine:
Remove reflow hose between reflow pipe and warm-up unit and refit afterwards.

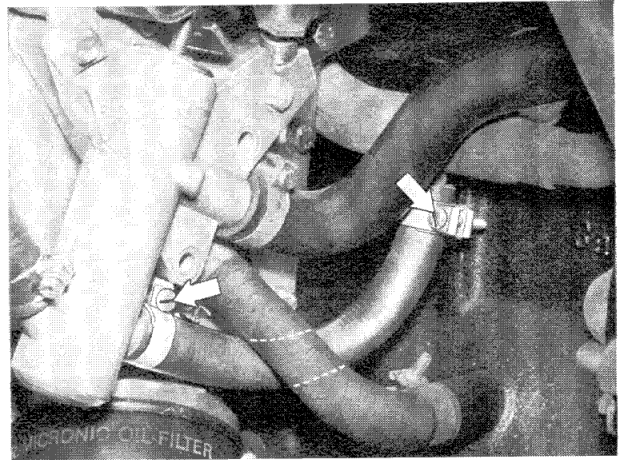

Applicable to injection engine:
Remove hose between branch stub and warm-up unit and refit afterwards.

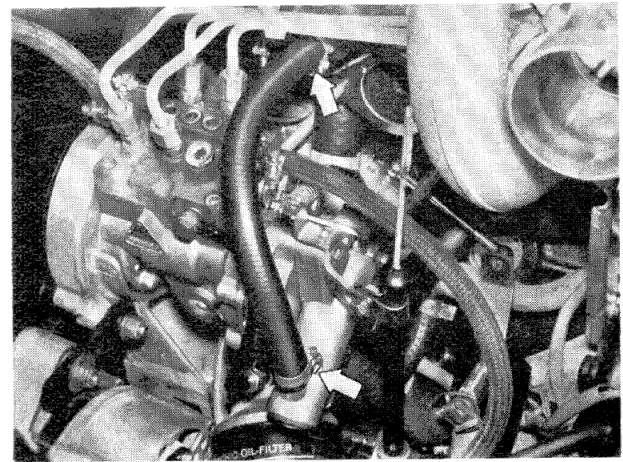

11 61 000 Replacement of intake pipe seals

(A) BMW 1602-2002

Drain coolant.

Note when refitting: Bleeding of coolant system cf. 11 53 000.

Removal and fitting of air filter housing cf. 13 71 000.

Unscrew locking bolt (1) and safety catch (2).

Pull out starter cable.

Note when fitting: Fasten starter cable sleeve.

Important: Sleeve must not project to the front by more than a maximum of 15 mm (0.5906") (A), as otherwise the starter butterfly cannot be closed properly.

Press starter cable into the bottom notch in the instrument panel.

Press starter lever (3) until it reaches stop.

With starter lever in this position, tighten locking bolt.

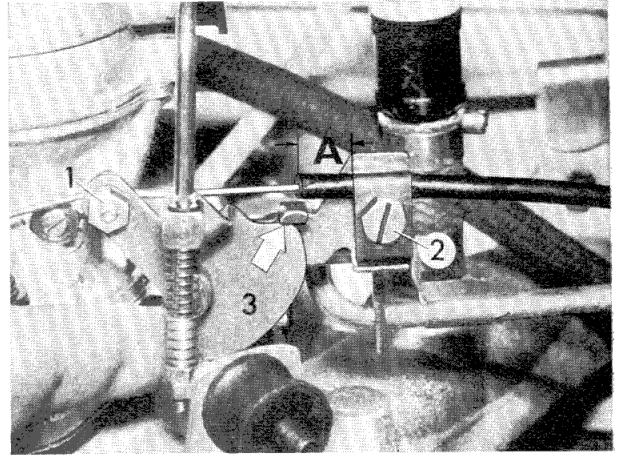

Press locking spring out of position.

Disconnect throttle linkage bars.

Pull off vacuum hoses on the carburettor and the intake pipe.

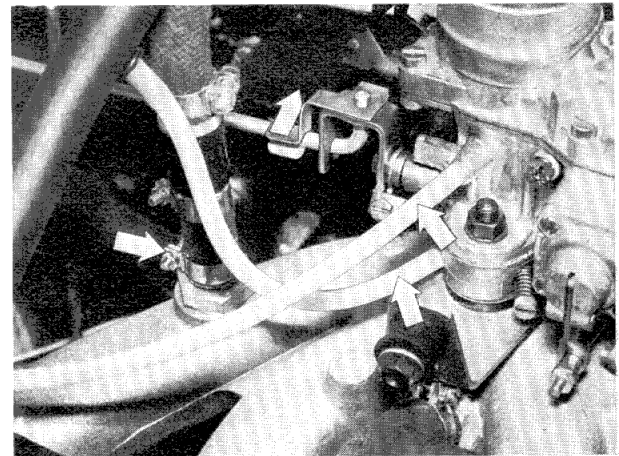

Pull fuel hose off the fuel pump and disconnect the cable for the thermometer switch.

Disconnect the coolant hoses from the branch stub.

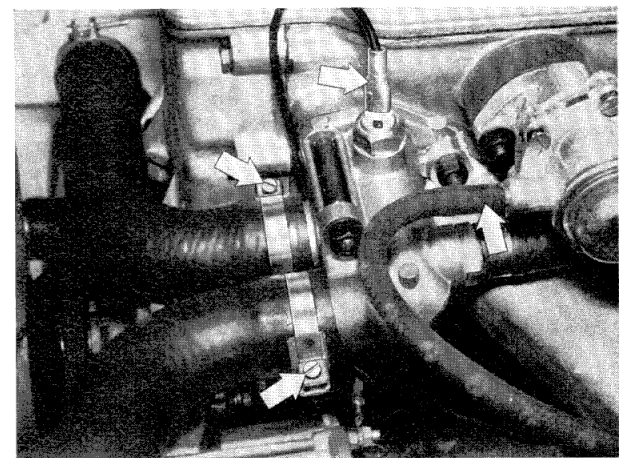

Unfasten oil dipstick support.

Disconnect warm water hoses from intake pipe.

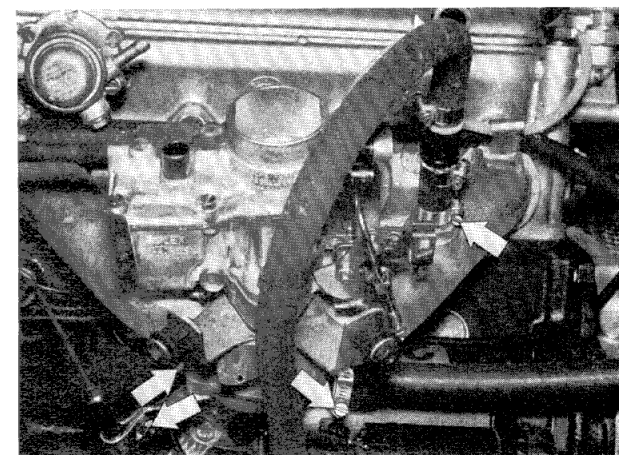

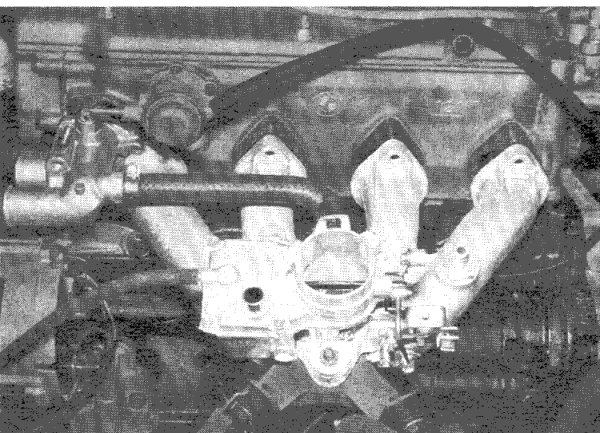

Detach intake pipe and branch stub from cylinder head.
Pull off intake pipe together with branch stub.

Note when fitting: Note that seals are fitted in correct position.

Fasten fuel hose clamp on the intake pipe for cylinder 4.

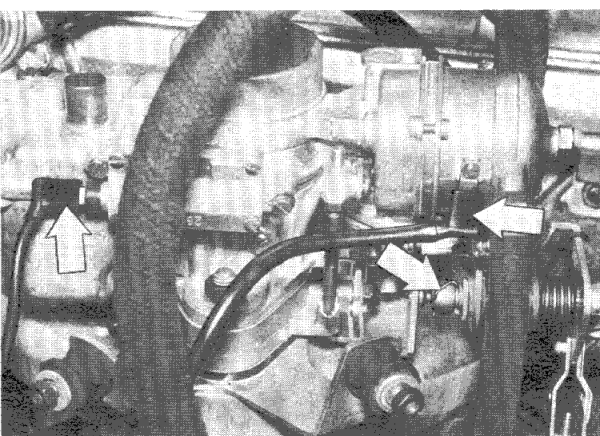

(B) BMW 2002 A

Pull cable off thermostat valve and starter cover.

Remove safety catch from shaft.

Press shaft out of position.

All further operations are identical to those applicable to the 1602-2002.

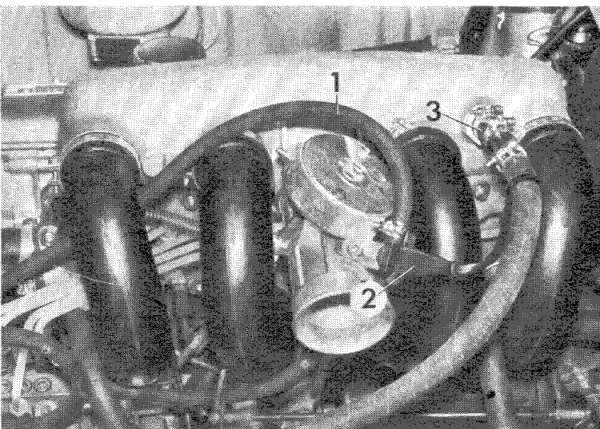

11 61 050 Removal and fitting of intake air collector with butterfly manifolds

(A) Version with induction resonator pipes:

Removal of entire air filter housing cf. 13 71 000.

Remove fuel hose (1), starter valve cable (2), vacuum hose (3), and all induction resonator pipes.

Note when fitting: Check string rings and replace if necessary.

(Cf. removal of induction resonator pipes 11 61 370)

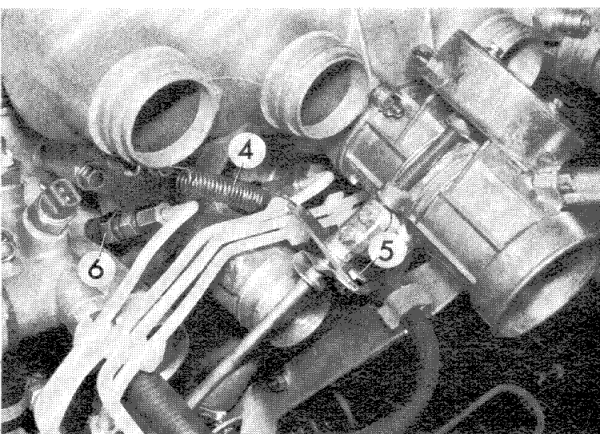

Disconnect pull spring (4).

Unscrew bolt (5) and remove injection pipe from cylinder 1.

Important: When unscrewing cap nut, secure pipe connection against turning.

Remove injection valve (6).



Unscrew bolts (7) and (8) on the throttle butterfly manifolds.
Remove vacuum hose (9), auxiliary air hose (10) and injection pipe (11) from cylinder 4.

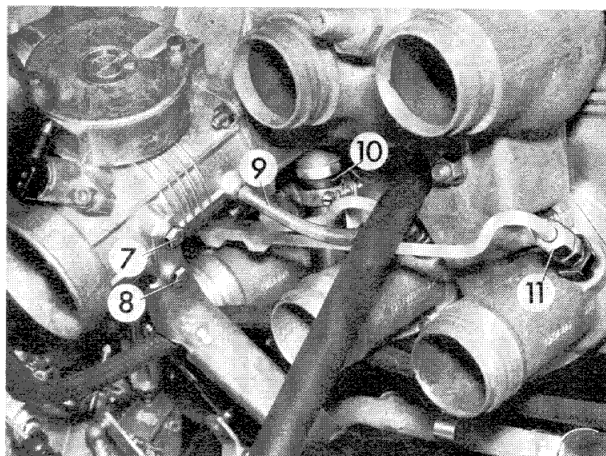

Important: When unscrewing cap nut, secure pipe connection against turning.
Remove air collector from cylinder head.
Note when fitting: Replace seal between fuel pump flange and air collector.

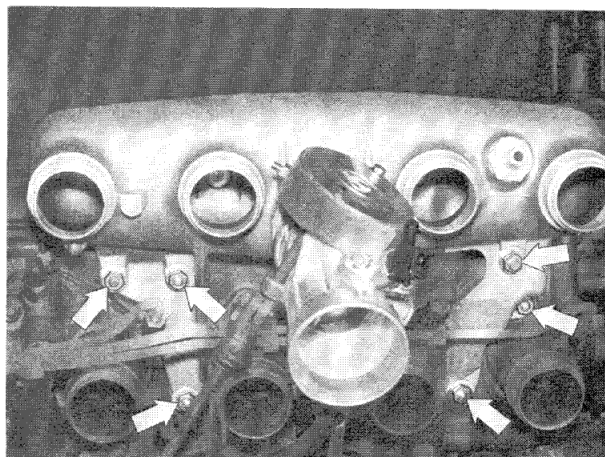

(B) Version with induction manifolds:
Removal of entire filter housing cf. 13 71 000.
Remove fuel hose (1), starter valve cable (2) and vacuum hose (3).

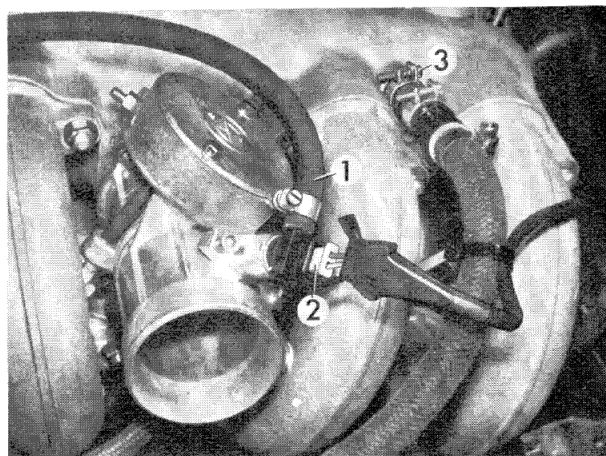

Unscrew bolt (4) and remove fuel reflow hose (5).
Important: Make sure that hose clamp (A) is located at the front in a vertical position, as otherwise the safety cap on the fuel enrichment valve may be blocked.

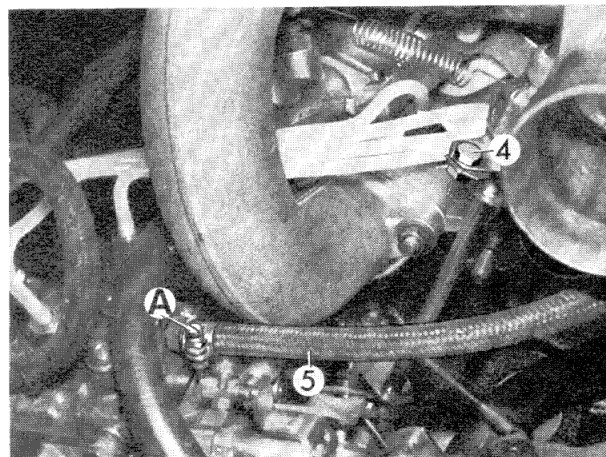

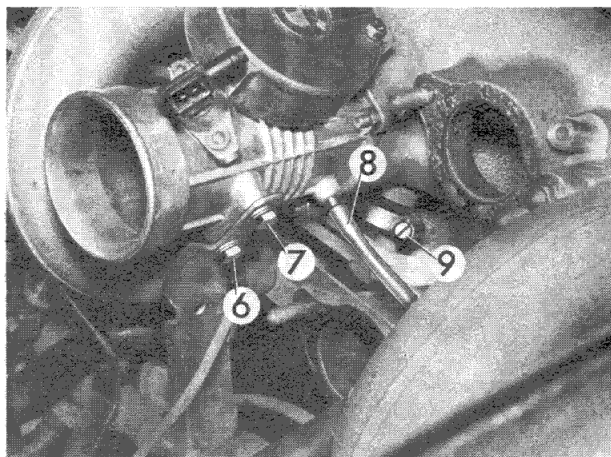

Unscrew bolts (6) and (7) on the throttle butterfly manifolds.
Detach vacuum hose (8) and auxiliary air hose (9).

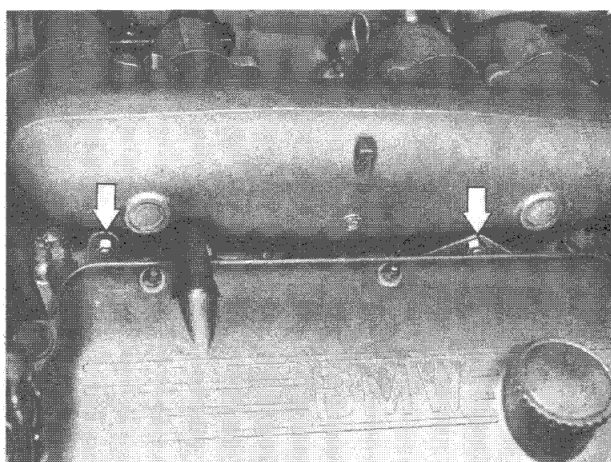

Remove air collector from support brackets.

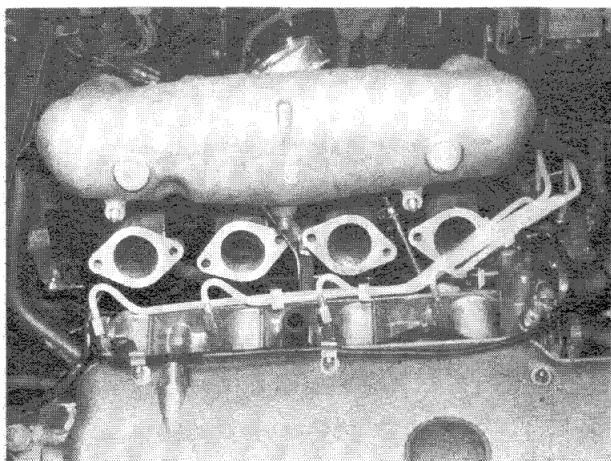

Remove all induction manifolds at bottom from the intake pipes.

Take out air collector together with induction manifolds and throttle butterfly manifolds while pressing the support brackets away from the throttle butterfly manifolds.

Note when fitting: Check seals and replace if necessary.



11 61 051 Replacement of intake air collector

(A) Version with induction resonator pipes:

Removal of intake air collector together with throttle butterfly manifolds cf. 11 61 050.

Remove throttle butterfly manifold (1).

Convert connections for auxiliary air (3) and vacuum hose (4).

Note when fitting: Replace seal (2).

Synchronize throttle butterfly and injection pump cf. 13 54 004.

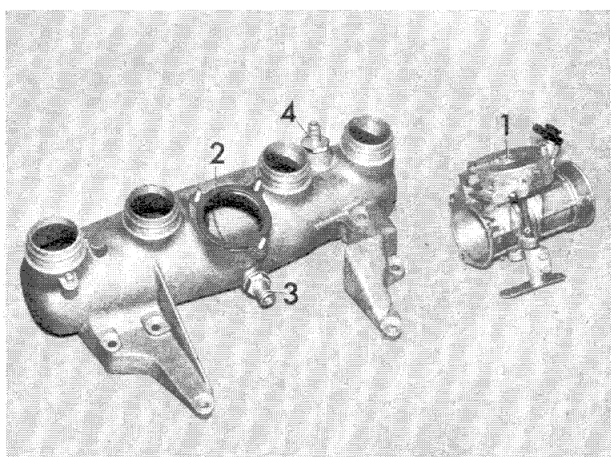

(B) Version with induction manifolds:

Detach all induction manifolds and throttle butterfly manifolds from air collector.

Note when fitting: Replace seals.

Fit induction manifolds in position, but do not tighten until they have been assembled on the engine.

Synchronizing of throttle butterfly and injection pump cf. 13 54 004.

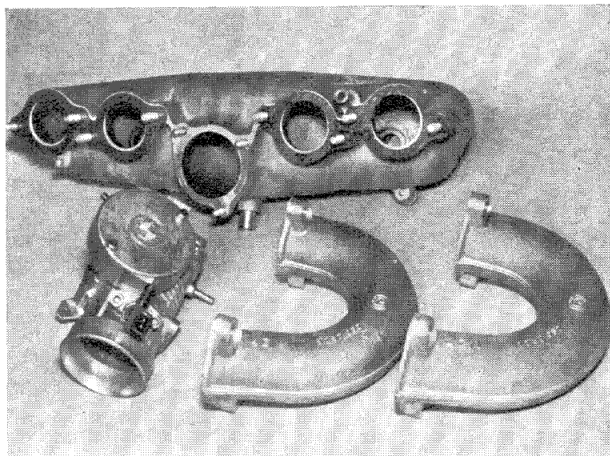

11 61 091 Replacement of auxiliary air hose

Removal of entire air filter housing cf. 13 71 000.

Remove induction resonator pipe from cylinder 3.

Note when fitting: Check string rings and replace if necessary.

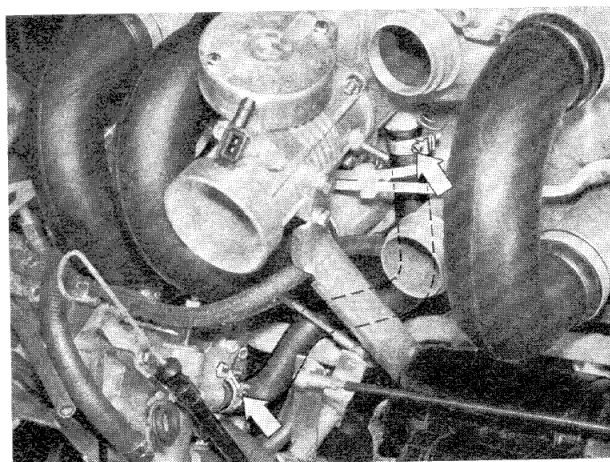

11 61 100 Replacement of front intake pipe seals

Remove hose.

Applicable to 2002 T1 only:

Drain coolant.

Note when fitting: Bleeding of coolant system cf. 11 53 000.

Removal and fitting of air filter housing cf. 13 71 000 (B).

Remove bearing support.

Disconnect pull rod.

Pull fuel hose off carburettor.

Detach vacuum hose.

Remove oil dipstick support.

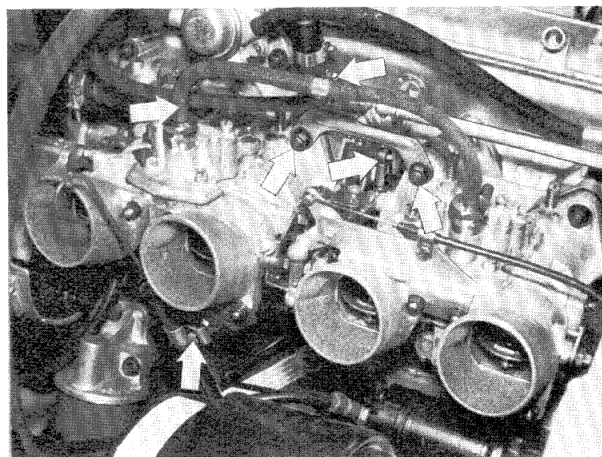

Pull cable off remote thermometer switch.

Detach coolant hoses from branch stub.

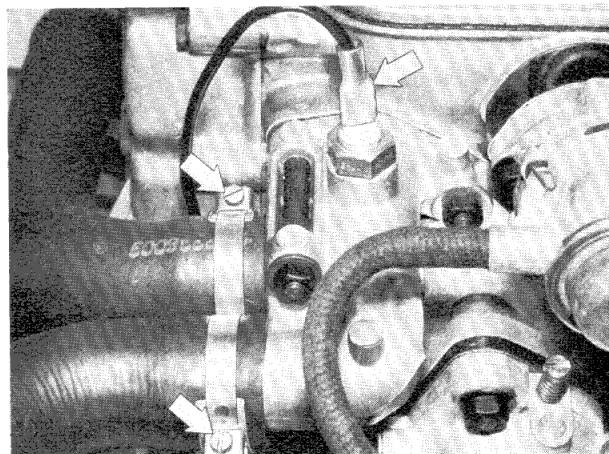

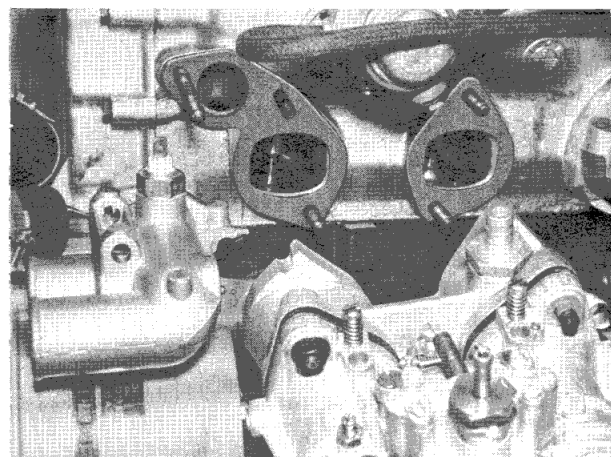

Pull out dipstick.
Remove intake pipe from cylinder head.
Pull off branch stub and intake pipe together with carburettor.

Note when fitting: Note correct position of seals.

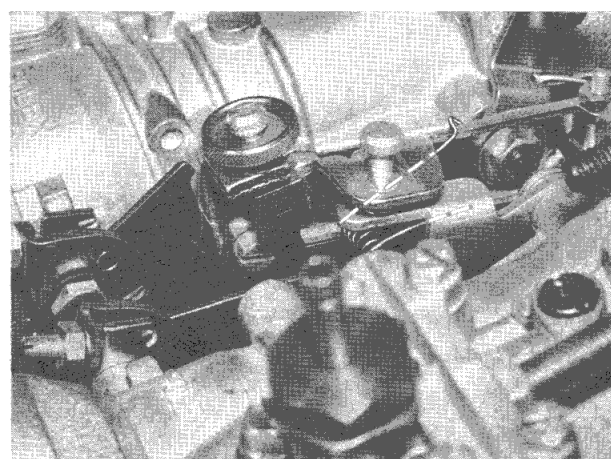

Note when fitting: Note correct position of torsion spring.

Before fastening the intake pipe, ease cam into the starter butterfly lever, which must be pulled back a bit.

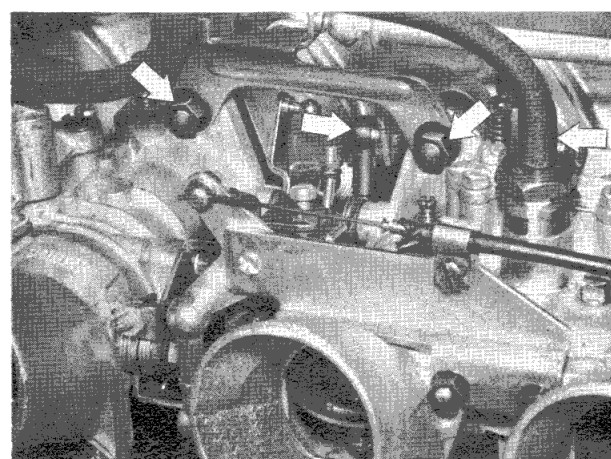

11 61 120 Replacement of rear intake pipe seals

Applicable to 2002 T1 only:

Remove bearing support.

Disconnect pull rod.

Pull fuel pipe off carburettor.

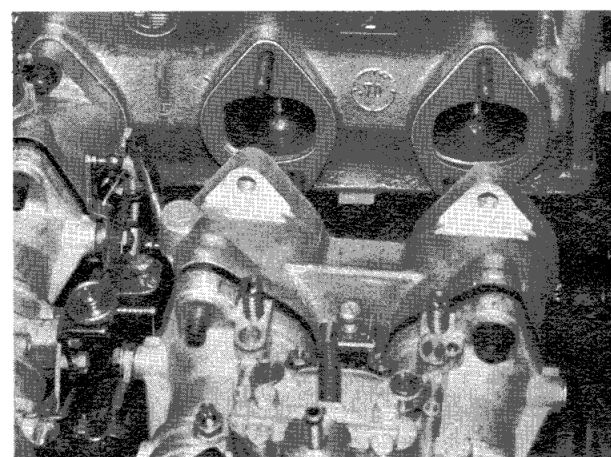

Detach intake pipe from cylinder head.

Pull off intake pipe together with carburettor.

Note when fitting: Note correct position of seals.

Fasten fuel hose clamp to the intake pipe of cylinder 4.



Note when fitting: Note correct position of torsion spring.

Before fastening the intake pipe, ease cam into the starter butterfly lever, which must be pulled back a bit.

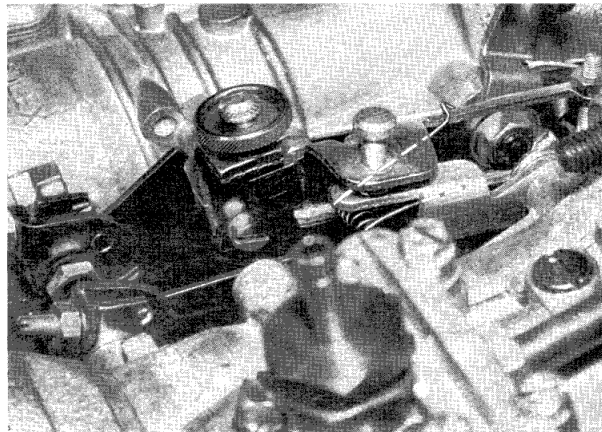

11 61 180 Replacement of cover seal on intake pipe

(A) BMW 1602-2002

Drain coolant.

Note when fitting: Bleeding of coolant system cf. 11 53 000.

Disconnect warm water hoses (1) and (2) from cover. Loosen oil dipstick support.

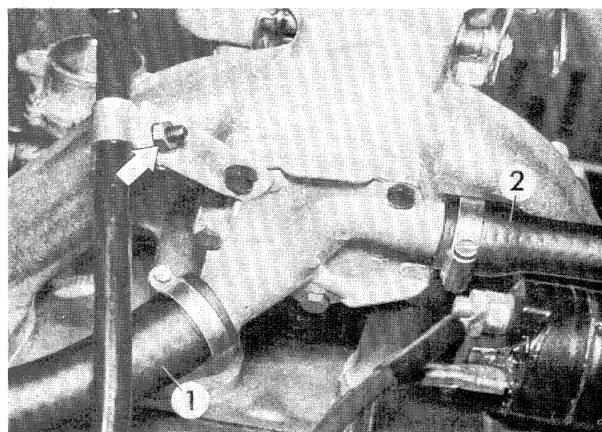

Applicable to BMW 2002 A only:

Detach warm water hoses (3÷5) from cover.

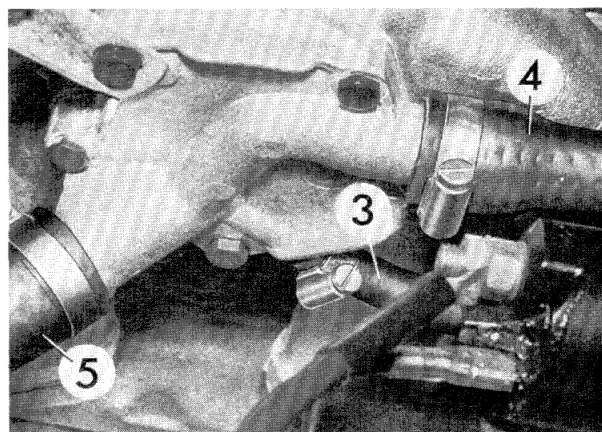

Remove cover.

Clean sealing surface.

Replace seal (6).

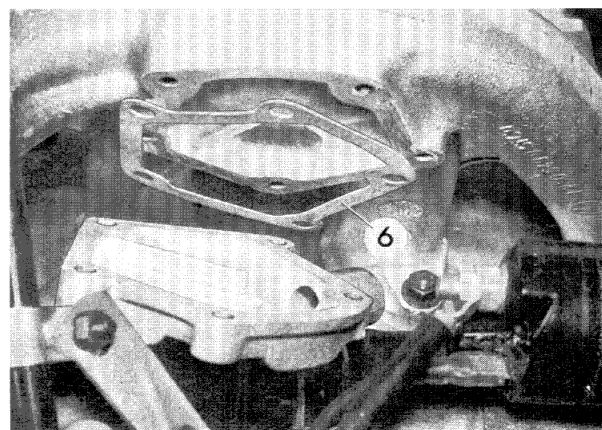

11 61 290 Removal and fitting of intake pipe

Removal of air collector together with throttle butterfly manifolds cf. 11 61 050.

Drain coolant.

Note when fitting: Bleeding of coolant system cf. 11 53 000.

Disconnect injection pipes (1) ÷ (4) from the injection valves.

Important: When unscrewing cap nuts, secure by means of spanner.



Disconnect water hoses. Pull cables off remote thermometer switch and temperature switch.



Detach intake pipes and branch stub from cylinder head.

Note when fitting: Fasten supports (1) and (2) on intake pipes.



Remove intake pipes together with.

Note when fitting: Check seals and replace if necessary.

Important: Note that seals are out of centre.

Seal (A) correct; seal (B) wrong.

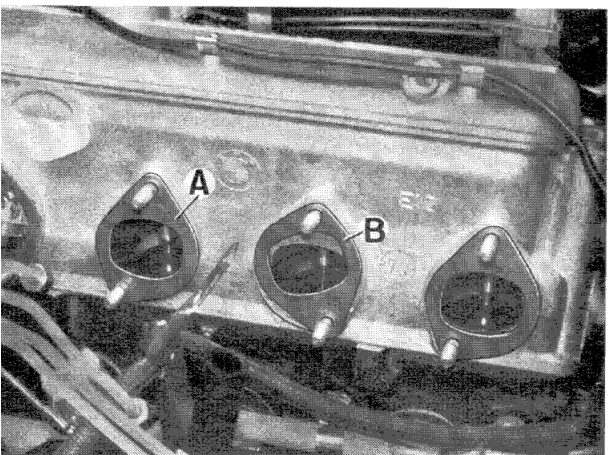
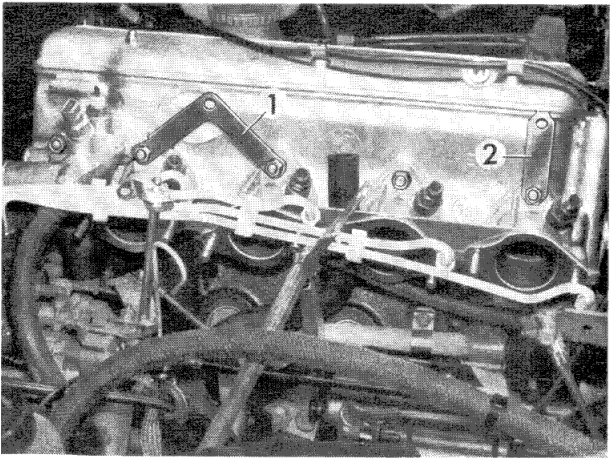
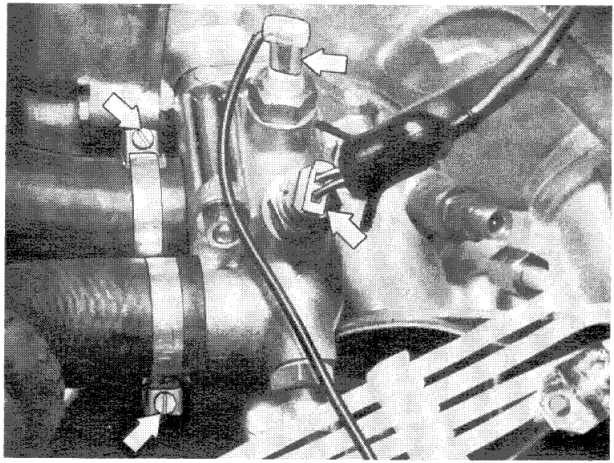
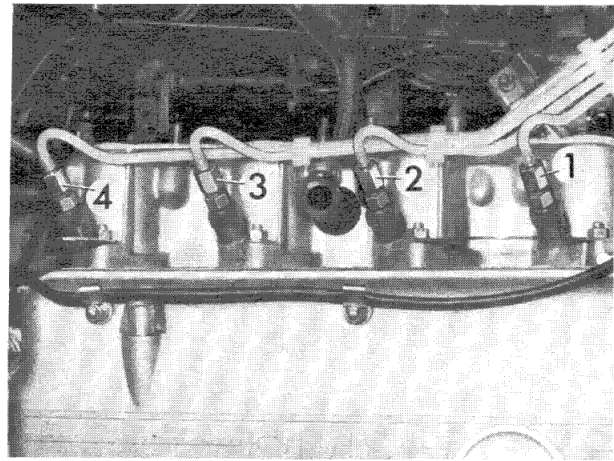

11 61 291 Replacement of intake pipe

Removal intake pipes cf. 11 61 290.

Convert injection valves.

Note when fitting: Check sealing rings (1) and replace if necessary.

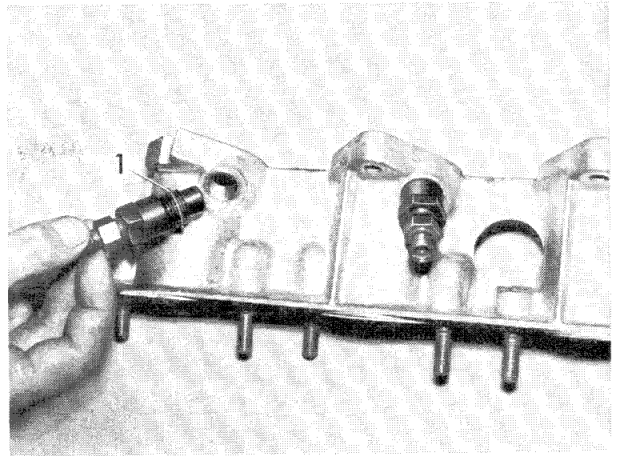

11 61 370 Removal and fitting of one induction resonator pipe

Loosen clamps.

Pull off resonator pipe.

Note when fitting: Tighten string rings on air collector and intake pipe. To make fitting easier, coat string rings with grease.

Push induction resonator pipes into position until stop is reached. Lead fuel pipe between induction resonator pipes (1) and (2) of cylinder 1.

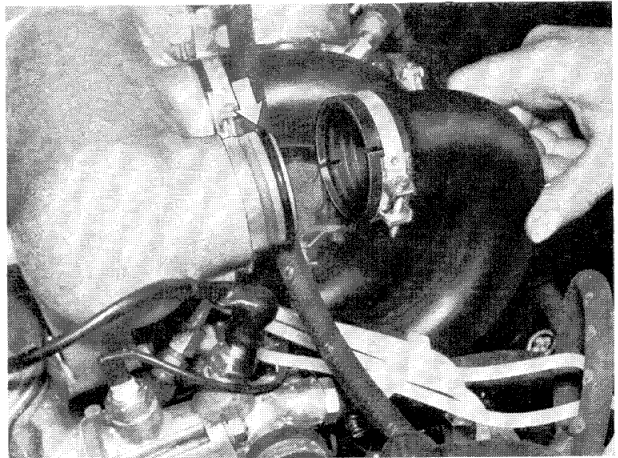

Important: To check pipes for tightness, spray fuel on the ends the induction resonator pipes. If the resonator pipes are not absolutely tight, this will make the engine run unsmoothly when idling.

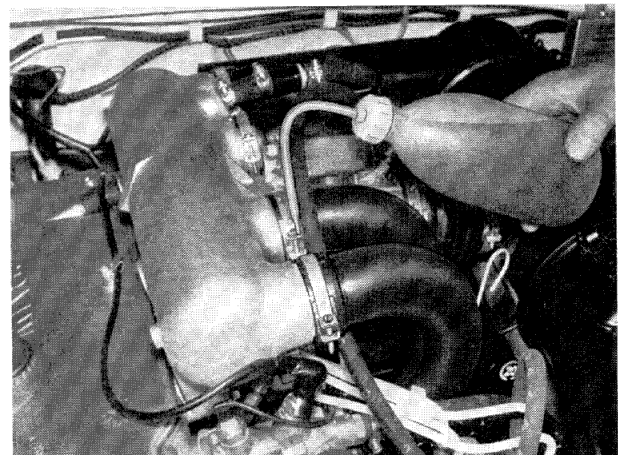

11 61 420 Removal and fitting of all intake manifolds

Detach intake manifolds from cylinder head and intake pipes.

Note when fitting: Replace seals.

If only one intake manifold is removed, cut off seal (1) behind the stud.

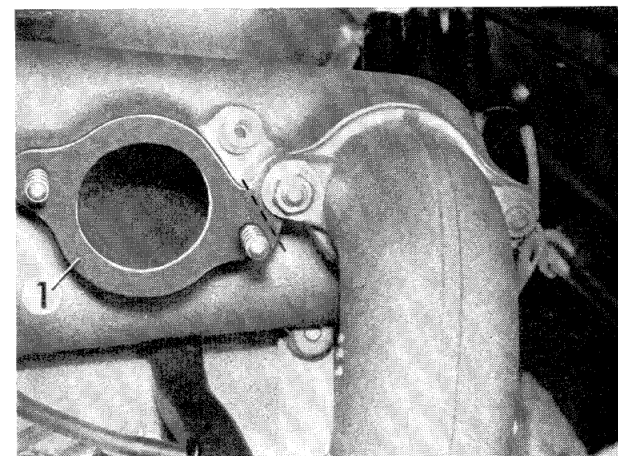

11 62 000 Gaskets for exhaust manifold — renewing

Remove guide sleeve for hot air 11 62 051.
Slacken exhaust support.
Remove exhaust pipe (4) from exhaust manifold.

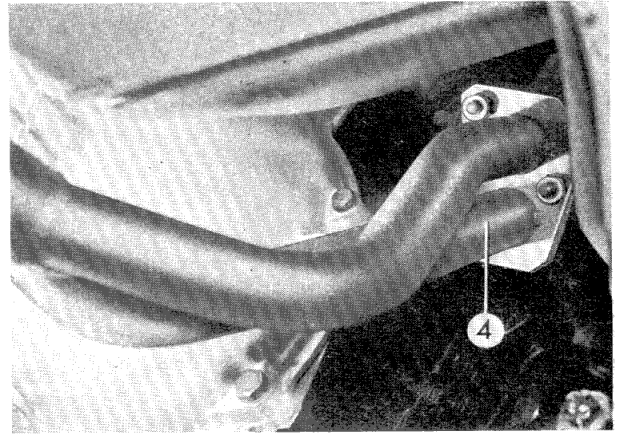

Fitting instruction: Secure exhaust pipe to exhaust manifold.

Loosen retaining plate (1).

Press support (2) without tension against the exhaust pipe.

Secure retaining plate (1) to gearbox and support.

Then tighten bracket (3).

If any other fitting sequence is used, severe booming noises can result.

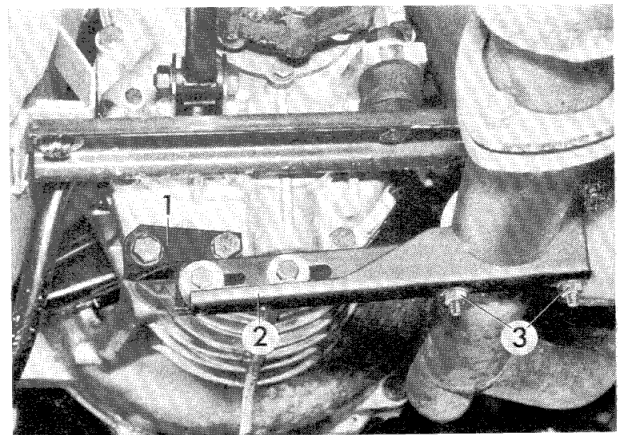

Detach exhaust manifold from cylinder head and remove.

Fitting instruction: Note correct fitted position of gaskets.

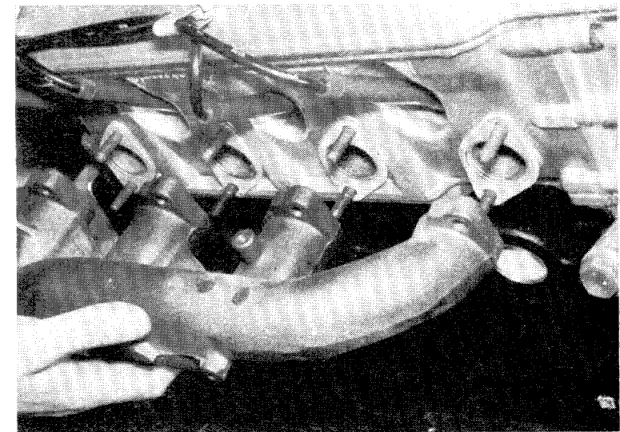

11 62 051 Guide sleeve for hot air — renewing

Pull off air hose with spacer ring.
Unscrew screws.
Remove guide sleeve.

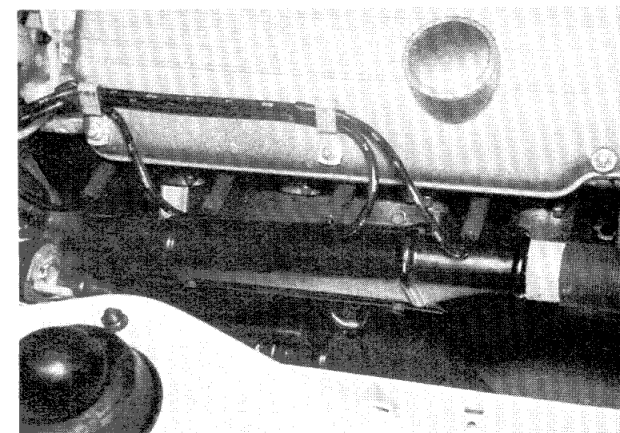

11 64 009 Checking and adjusting of emission control unit

— version with air pump —

Setting of ignition timing

This can only be done if the dwell angle has been set perfectly. Pull vacuum hose off distributor.

With engine at normal operating temperature, set engine speed to 2000 rpm. Point strobe light at steel ball in flywheel.

The ignition timing has been set correctly if the middle of the steel ball can be seen at the edge of the sight hole.

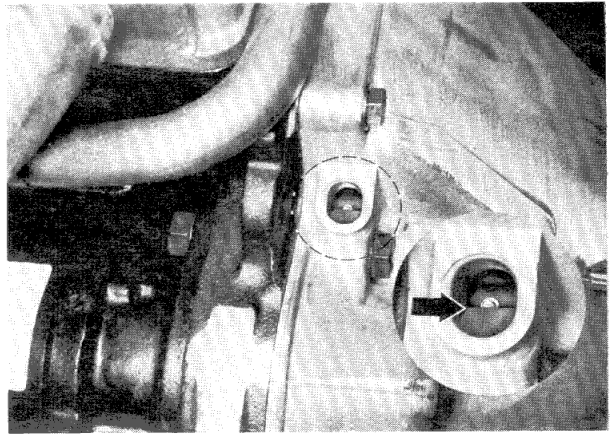

When adjusting ignition timing statically — or with engines without a steel ball in the flywheel or without a sight hole in the gearbox housing — set ignition timing with the help of marks in the pulley.

1. TDC notch
2. Notch showing static ignition timing
3. Notch showing ignition timing at 2000 rpm

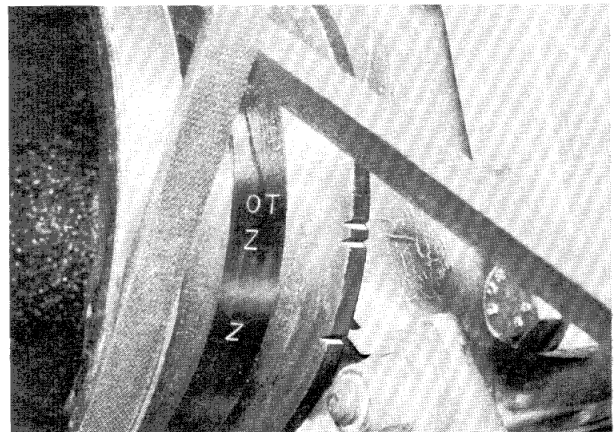

Setting of carburetors

Connect emission tester.

With engine at normal operating temperature, set engine speed to 1000 rpm.

Adjust CO-volume to $1 \div 1.2$ % by means of idling mixture adjustment screw.

Correct engine speed until engine is running at 1000 rpm and repeat adjustment procedure until the prescribed CO-values have been reached.

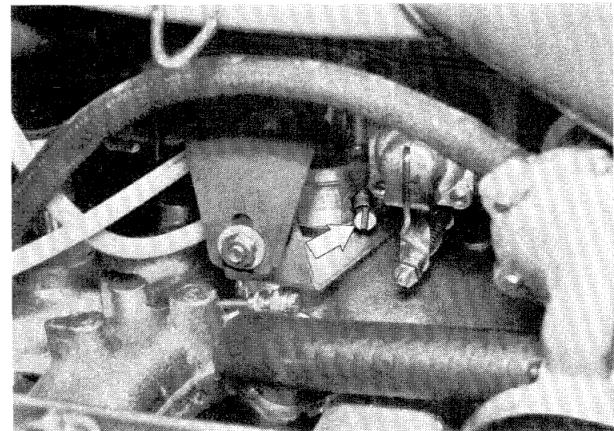

Removal and fitting of air filter

Note hose connections.

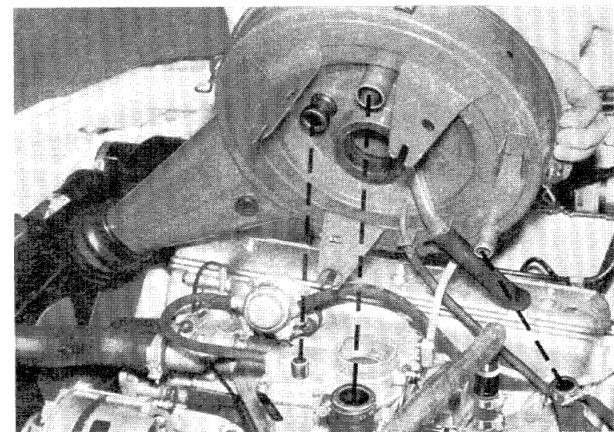

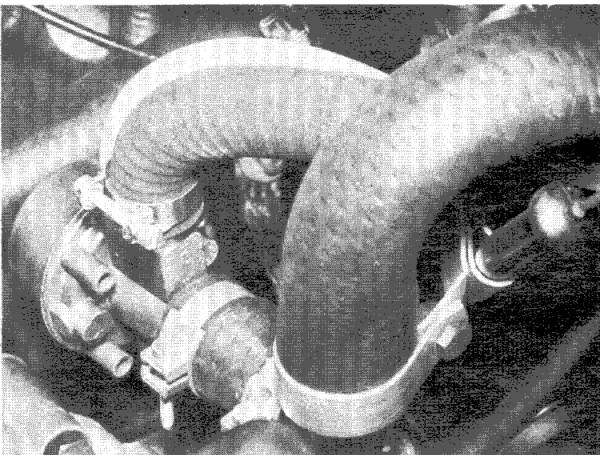

Control valve

Replace control valve,

- (a) if it is difficult to adjust carburettors.
- (b) if car backfires when foot is taken off throttle.

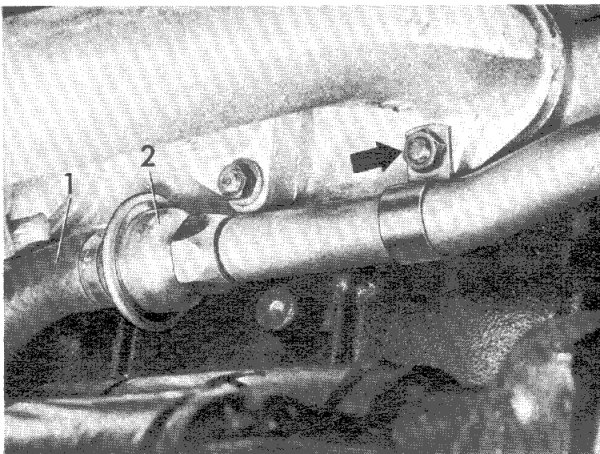

Check valve

Disconnect hose (1) and pipe clamp.

Screw check valve (2) off manifold.

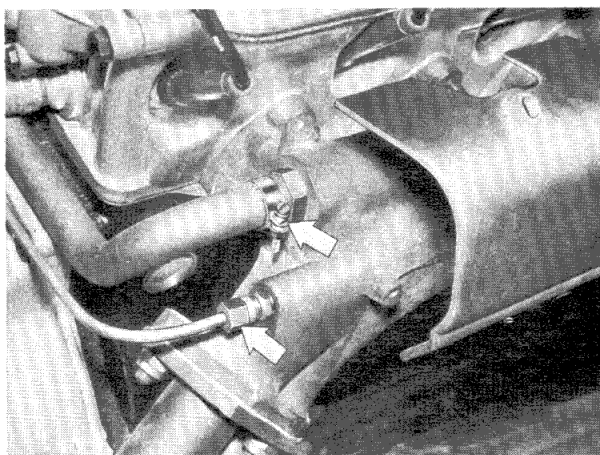

Blow-in pipe

Remove cover, manifold and exhaust gas recirculation pipe.

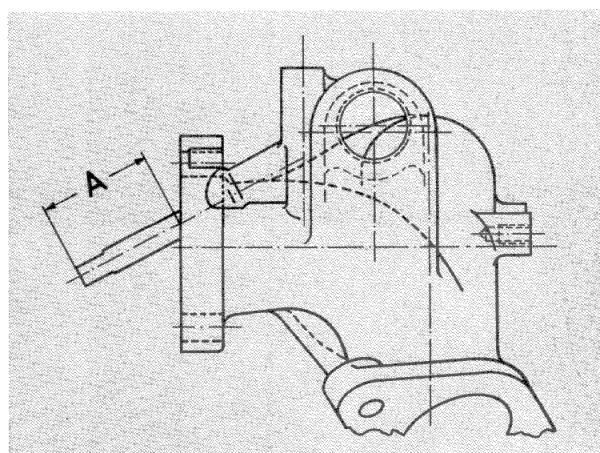

Remove exhaust manifold from exhaust pipe and cylinder head.

Note when fitting: Note correct position of seals.

The blow-in pipes are screwed into the exhaust manifold.

When replacing, note assembly length A 37 - 1 mm (1.4567" - 0.0394").



Pressure regulating unit

Check for correct operation.

Remove return pipe.

Press palm of your hand slightly onto the pressure regulating unit.

The excess pressure valve must open between 1700 ÷ 2000 rpm.

If excess pressure valve opens earlier, the pressure regulating unit is defective.

If excess pressure valve opens at higher engine speed, replace air pump.

Ease pressure regulating unit out by means of two screwdrivers.

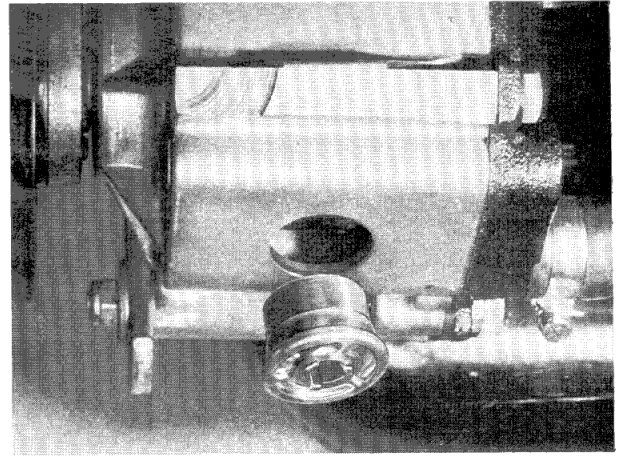

Air pump

Disconnect all hoses.

Remove air pump from support and clamp.

Note when fitting: Tighten bolts (1) to 4.5 mkp (32.54 ft/lb).

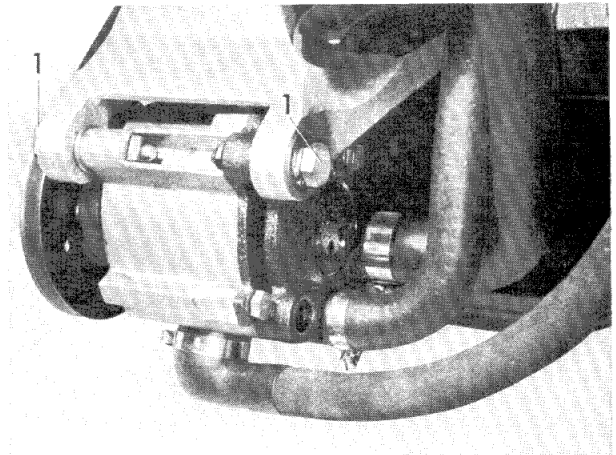

Check bearing bushes and replace if necessary.

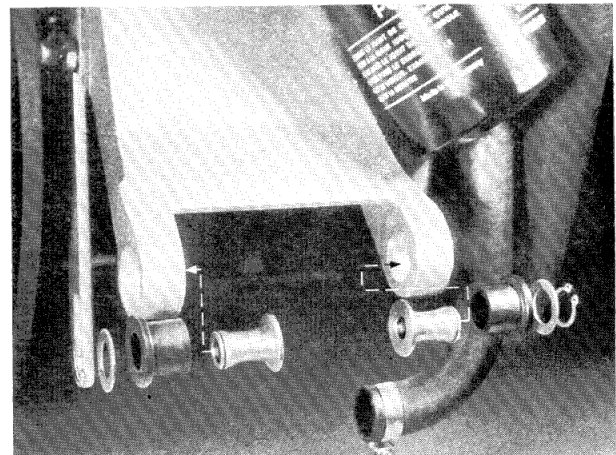

Adjust tension of V-belt so that it can be pressed in by 5 ÷ 10 mm (0.19 ÷ 0.39").

Important: Do not use any kind of lever.

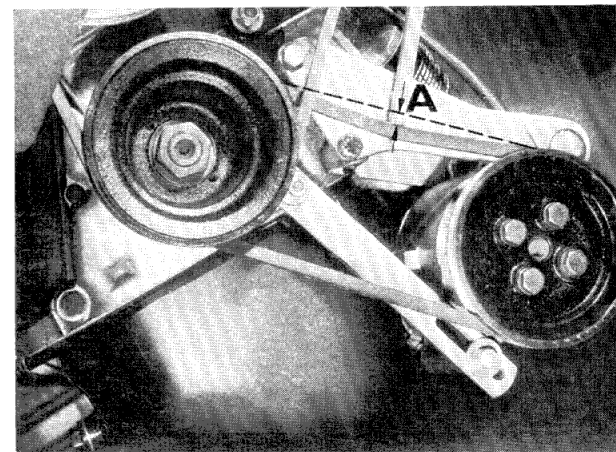

Emission control unit – version with air pump

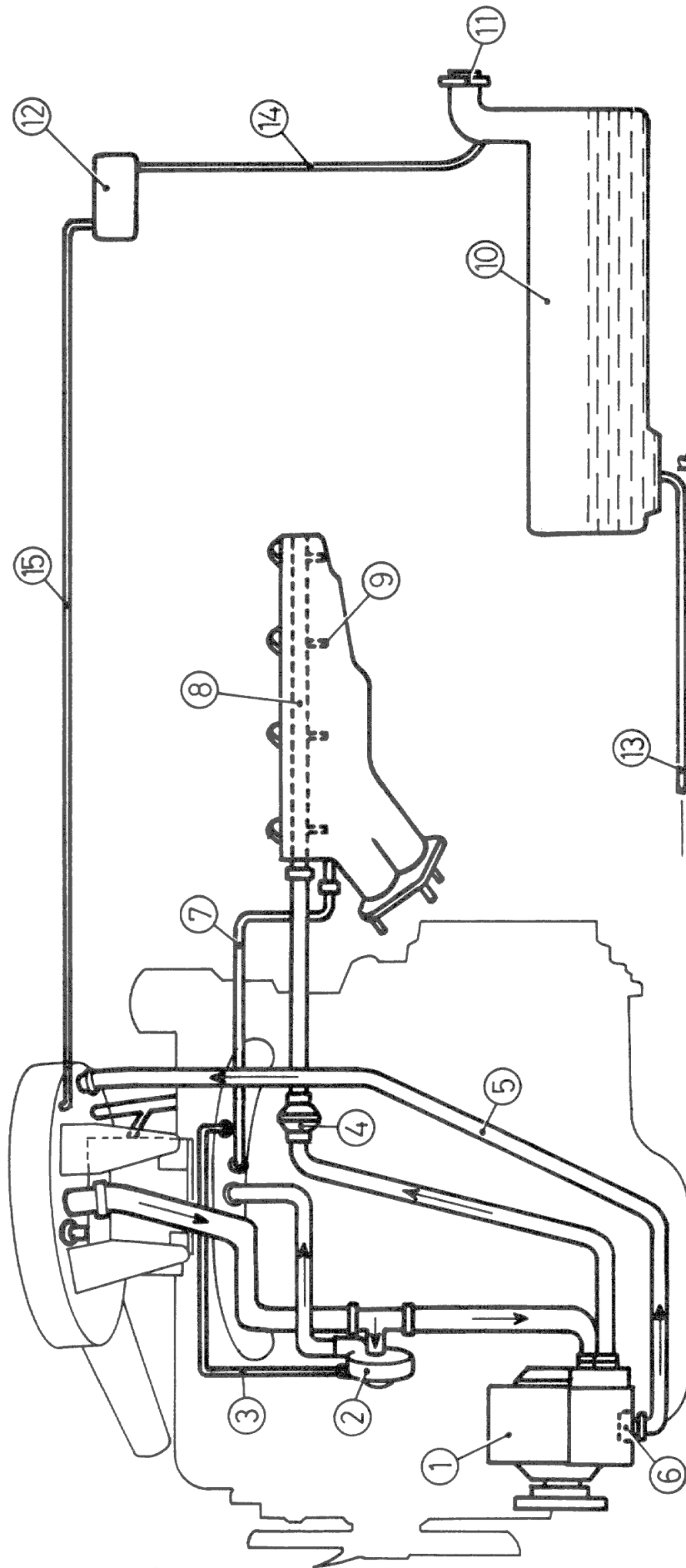

- | | | | |
|----|--------------------------------|----|-----------------------------------|
| 1 | air pump | 11 | fuel tank filler cap (not vented) |
| 2 | control valve | 12 | vapour storage line |
| 3 | control pipe | 13 | fuel pipe |
| 4 | check valve | 14 | vapour purge line |
| 5 | return pipe for excess air | 15 | purification pipe |
| 6 | pressure regulating unit | | |
| 7 | exhaust gas recirculation pipe | | |
| 8 | air distributor pipe | | |
| 9 | blow-in pipe | | |
| 10 | fuel tank | | |

Specifications for engine with emission control system
– version without air pump –

Displacement		121.3 cu. in
Exhaust control system		Engine modification, exhaust gas recirculation
Evaporative control system		Vapour storage tank, activated carbon filter
Ignition timing		25° BTDC at 1500 rpm
Distributor point dwell angle		59 ÷ 65°
Spark plugs		Bosch WG 175 T 30 or Champion N 11 Y
Idling speed		900 ± 50 rpm
CO-content at idle		0.8 ÷ 1.2 Vol. %
Carburettor		DIDTA
Choke		Automatic
Thermal starter valve opens at		-5° ÷ 10°C (22-50°F)
Fast idle speed		2300 ÷ 2500 rpm
Idle jet		45
Main jet	1st stage x 117.5	2nd stage x 137.5
Air correction jet	120	105
Venturi tube	24	28
By-pass opening	1.3/1.3	1.0/1.5
Float needle valve		2.0
Float needle valve seal ring		2.0 mm
Float		7.3 gr (0.255 oz)
Injection tube		50
Injection output per stroke		0.9 ± 0.1 cm ³

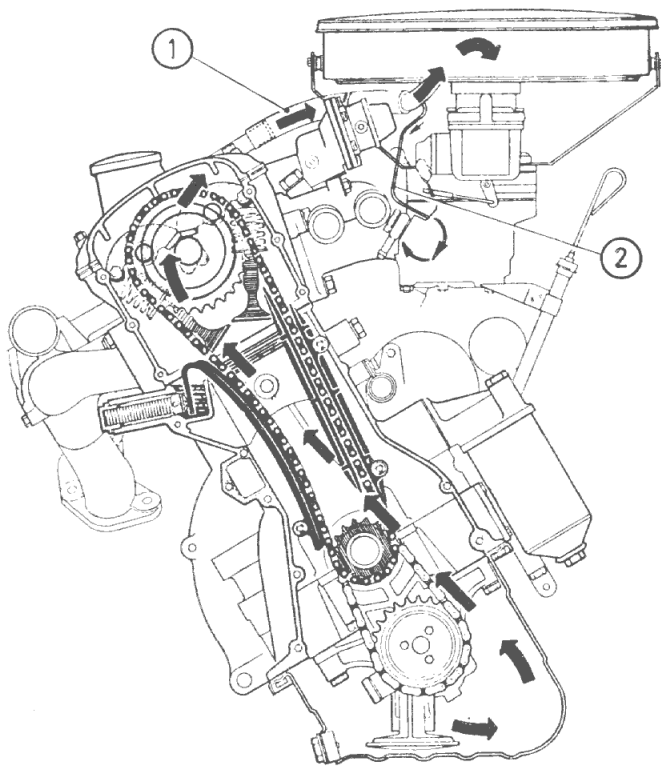

- 1 primary vent
- 2 secondary vacuum control
- 3 exhaust manifold
- 4 cyclone filter
- 5 coil
- 6 speed sensitive relay
- 7 distributor
- 8 two-way magnetic valve
- 9 diaphragm valve
- 10 intake manifold
- 11 dashpot
- 12 carburettor
- 13 pipe leading to vacuum unit
- 14 pipe leading to diaphragm valve

Crankcase emission control system

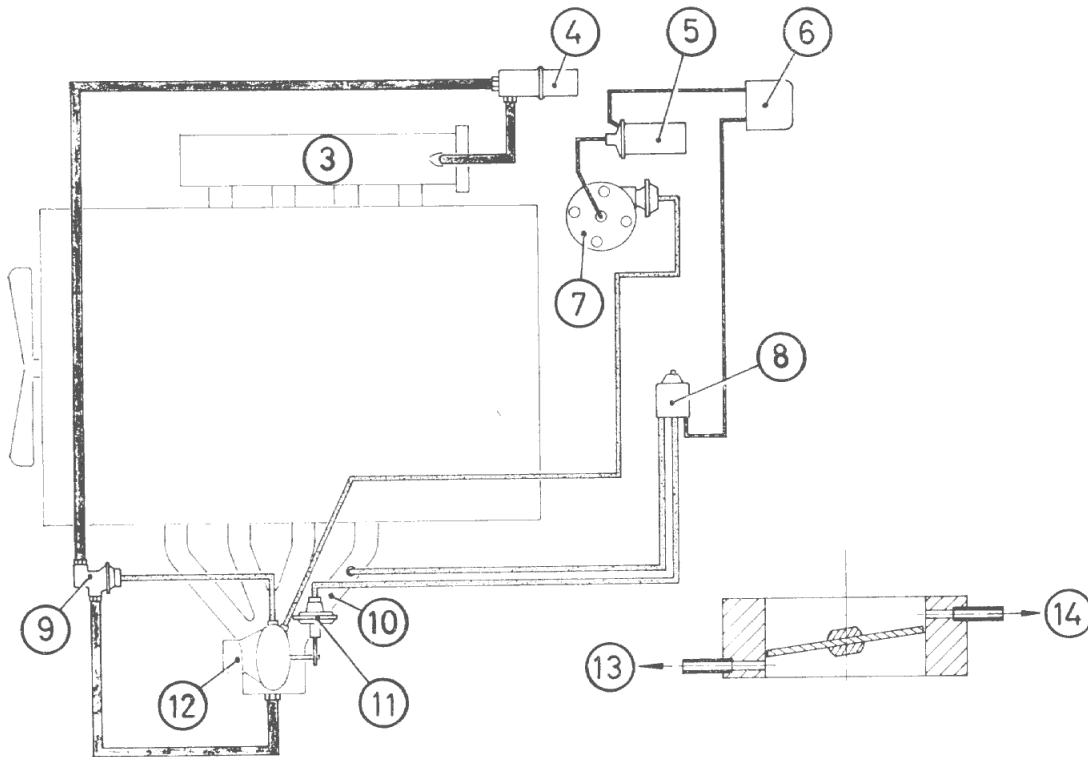

Exhaust emission control system

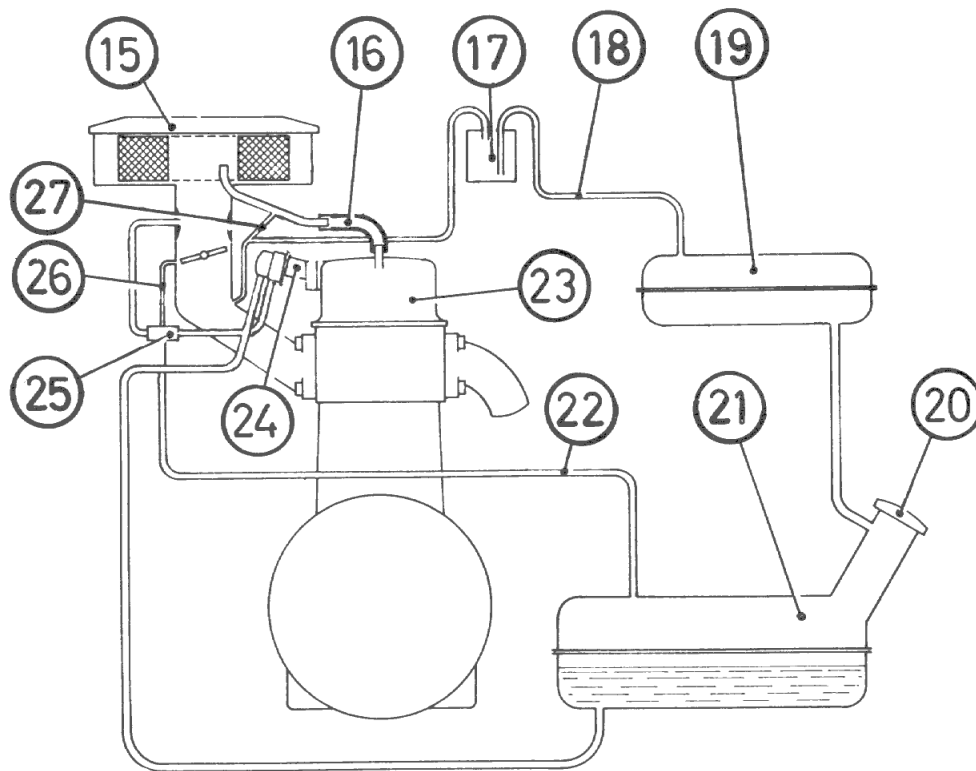

Evaporative control system

- | | |
|----------------------------|---------------------------------------|
| 15 air cleaner | 22 excess fuel pipe |
| 16 primary crankcase vent | 23 cylinder head cover |
| 17 activated carbon filter | 24 fuel pump |
| 18 vapour purge line | 25 fuel return control valve |
| 19 vapour storage tank | 26 vacuum hose |
| 20 sealed fuel filler cap | 27 secondary crankcase vacuum control |
| 21 fuel tank | |

Emission control unit
— version without air pump —

Adjust dwell angle

Connect BMW Programm Tester.
Check ignition contact points for perfect condition.

- 1 just acceptable
- 2 must be replaced

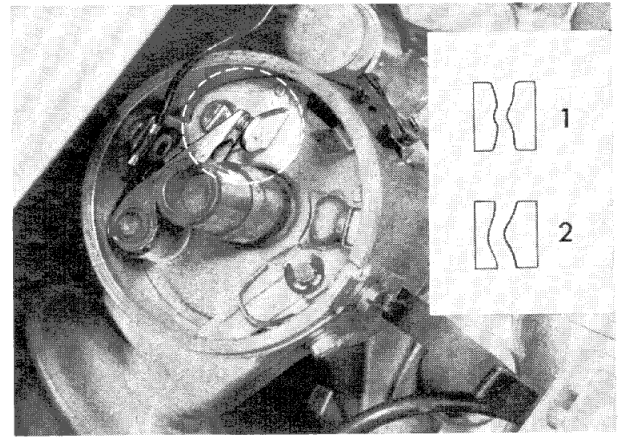

Adjust dwell angle to 59° - 65°.

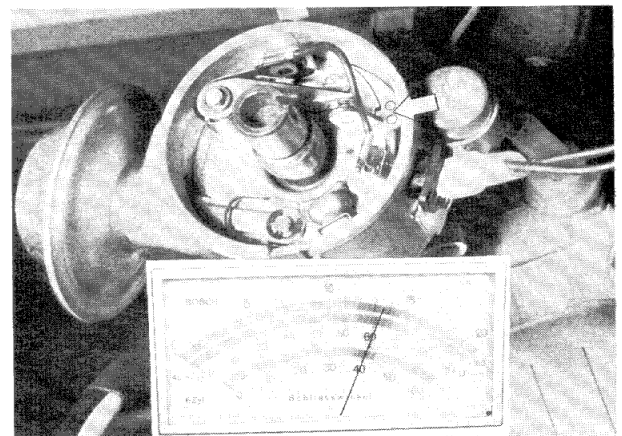

Adjust ignition timing

Remove air filter.

Note when fitting: Connect vapour purge line and vacuum hose.

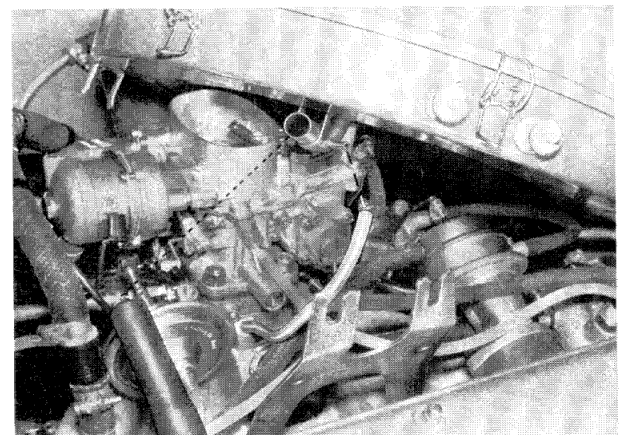

Pull vacuum hose off dashpot and seal.
Detach vacuum hose from distributor.
Unscrew nut (1).
By turning dashpot, increase engine speed to 1500 rpm.

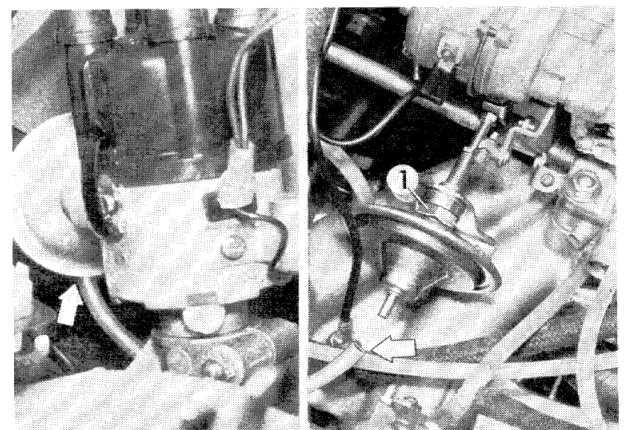

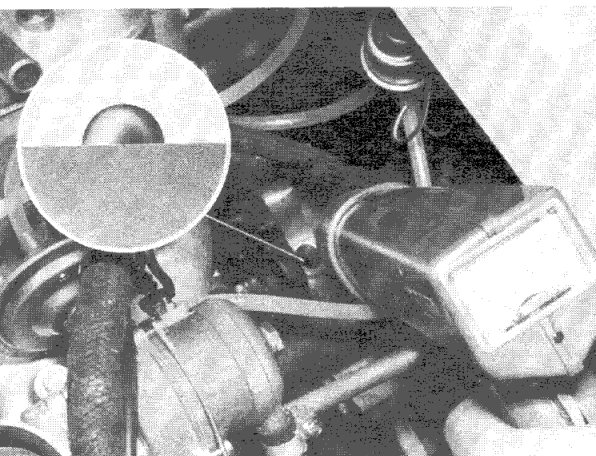

Switch off advance angle indicator on strobe light gun.
Loosen distributor and turn until the middle of the ball can be seen at the edge of the sight hole.

Fasten distributor again.

Connect vacuum hose to distributor.

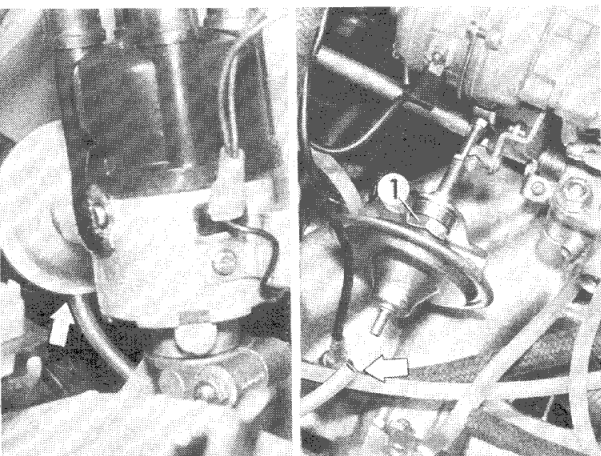

Adjusting dashpot

Pull vacuum hose off dashpot and seal.

Unscrew nut (1).

Set engine speed to 1600 ± 50 rpm by adjusting dashpot.

Then open vacuum hose and connect to dashpot.

The ignition retard is operating correctly if engine speed increases by several 100 rpm after the vacuum hose has been pulled off the distributor.

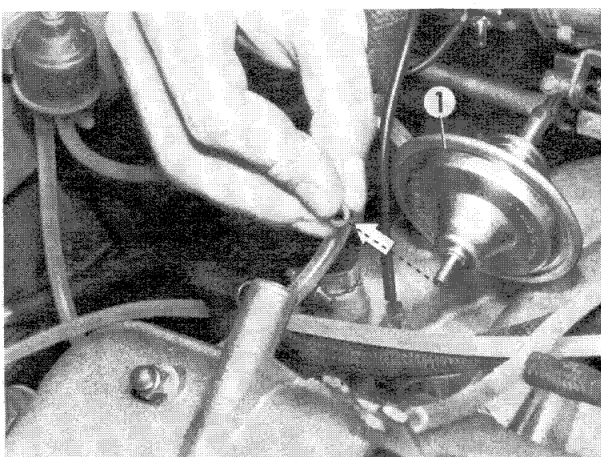

Dashpot (1) does not move up at engine speed of less than 1650 ± 100 rpm:

- a) Pull vacuum hose off dashpot and place fingertip on the end of the hose to find out if there is a vacuum.

If there is a vacuum in the hose, replace dashpot (1).

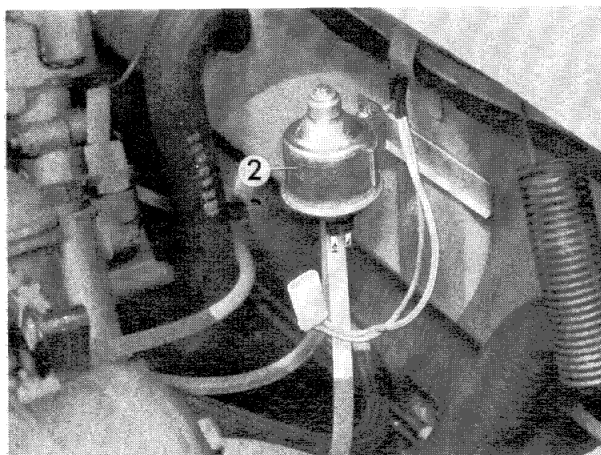

- b) No suction effect in the vacuum hose:

Pull cable off magnetic valve (2) and connect to a voltmeter.

Replace magnetic valve if the voltmeter reading is at least 12 V at an engine speed of more than 1900 rpm.



c) If the voltmeter shows no reading, connect the brown and red/white cable of engine speed switch (3) to the voltmeter.

If there is no reading at engine speeds in excess of 1900 rev/min, engine speed switch (3) is defective. ■

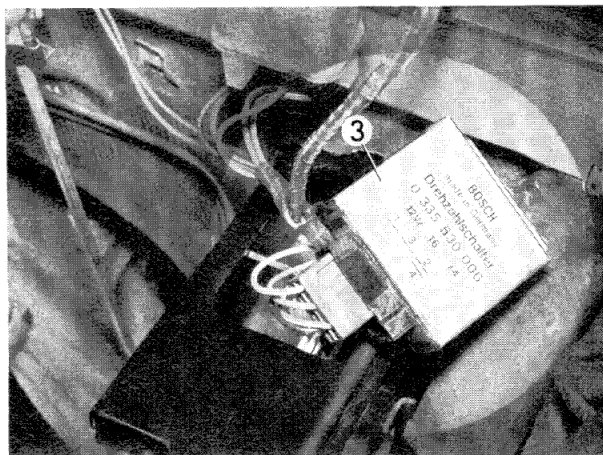

d) If the voltmeter shows a reading, replace relay (4). ■

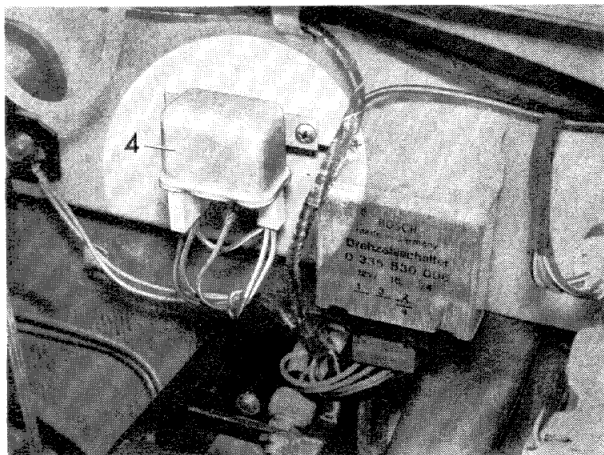

Adjusting engine idle speed and CO volume

Set engine idle speed to 900 ± 50 rev/min by turning screw (2).

By turning screw (3) correct CO volume to 0.8 ... 1.2 vol. %.

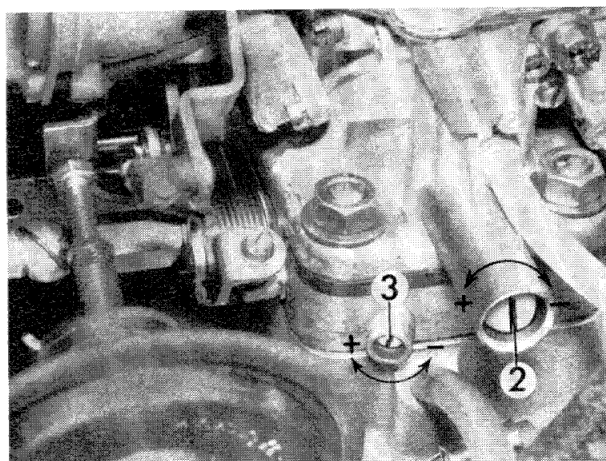

If the engine "hunts" or surges (i.e. if engine speed fluctuates), it is possible that throttle butterfly opening on the first or second stage is not correct.

Adjusting first-stage throttle butterfly opening:

Tighten screw (2) down to its seat.

By turning screw (4), set engine speed to 650 ... 700 rev/min.

By turning screw (3), set CO volume to approx. 3 vol. % Then loosen screw (2) again and correct CO volume to 0.8 ... 1.2 vol %, and engine idle speed to 900 ± 50 rev/min. ■

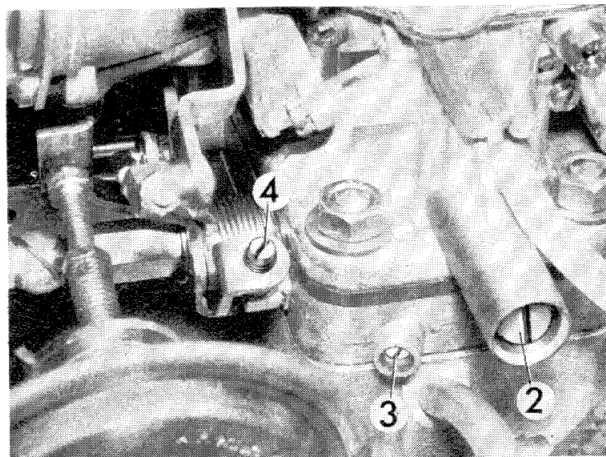

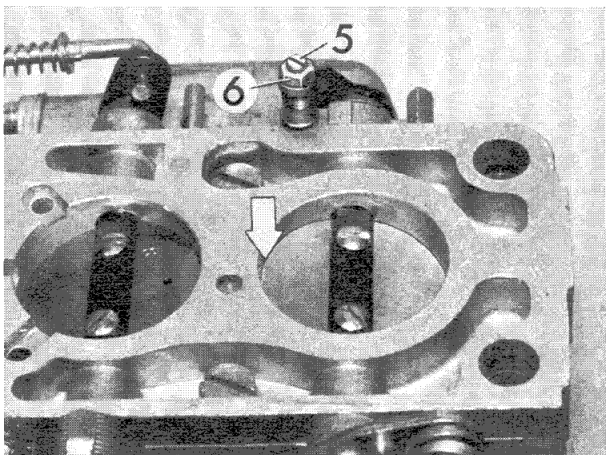

Adjusting second-stage throttle butterfly opening:
Remove carburetors.
Unscrew nut (6) and adjust throttle butterfly opening by turning screw (5) until light can just be seen through the gap.

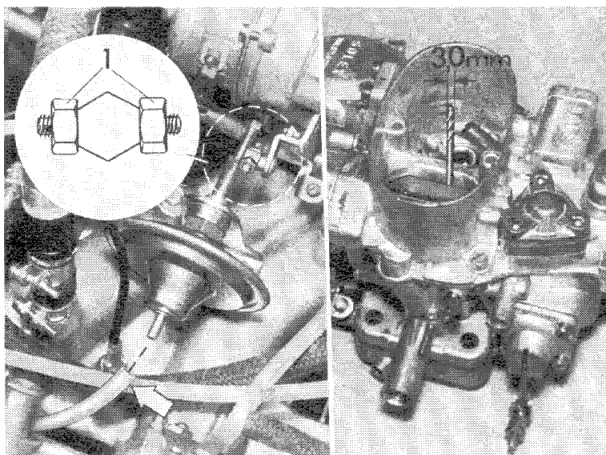

Adjust fast idle speed

With engine at normal operating temperature, pull vacuum hose off distributor.
Lift up accelerator linkage by a few millimetres.
Close choke butterfly by hand until the gap measures 3.0 mm (0.118 in). This will move the follower on to the second step on the disc. Start engine.
The fast idling speed of the engine should be between 2300 and 2500 rev/min. To correct fast idling speed, adjust linkage (1) after loosening the nuts.

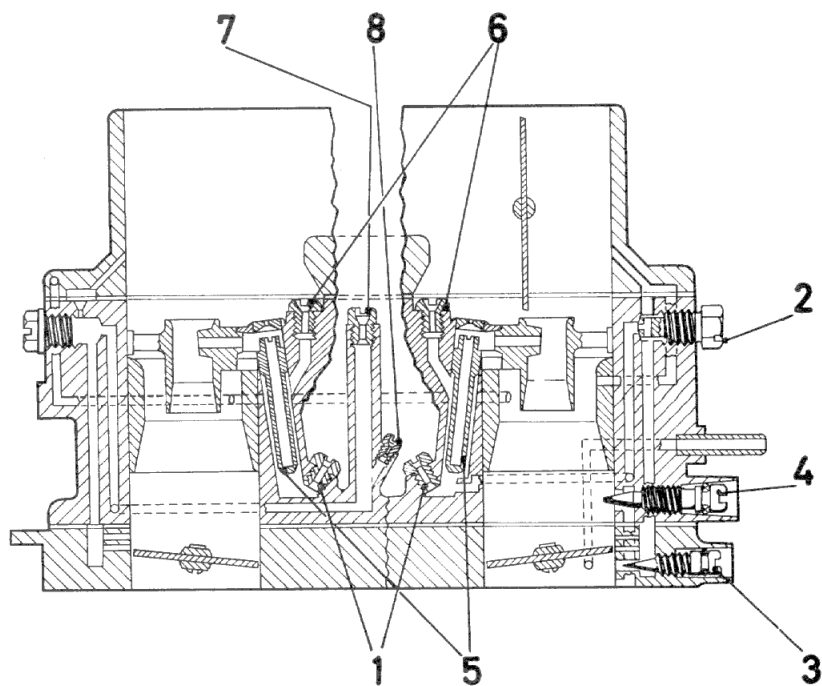

- | | |
|--|----------------------------------|
| 1 Main jet | 5 Mixing tube |
| 2 Idling jet | 6 Air correction jet |
| 3 Idling mixture regulating screw | 7 Air jet for transition reserve |
| 4 Air by-pass and engine idle speed adjustment screw | 8 Second-stage transition jet |

Exhaust gas recirculation system

Every 16.000 miles (24.000 km) clean the exhaust gas recirculation pipes from the exhaust manifold to the intake manifold on the inside using a suitable tool.

Important: Be careful not to roughen the inside of the pipes in the process.

Remove exhaust gas recirculation pipe from intake manifold and diaphragm valve.

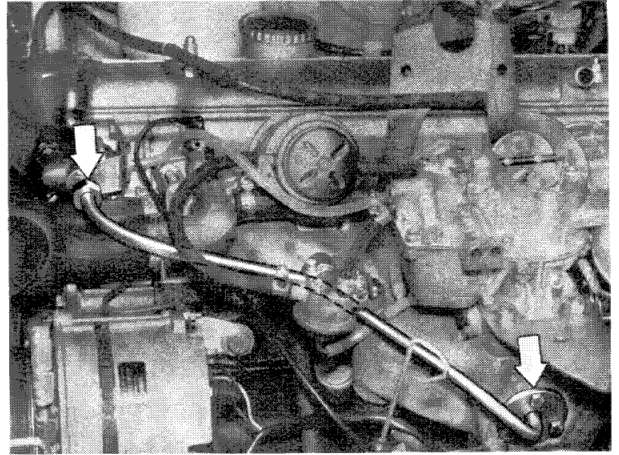

Remove exhaust gas recirculation pipe leading from diaphragm valve to cyclone filter.

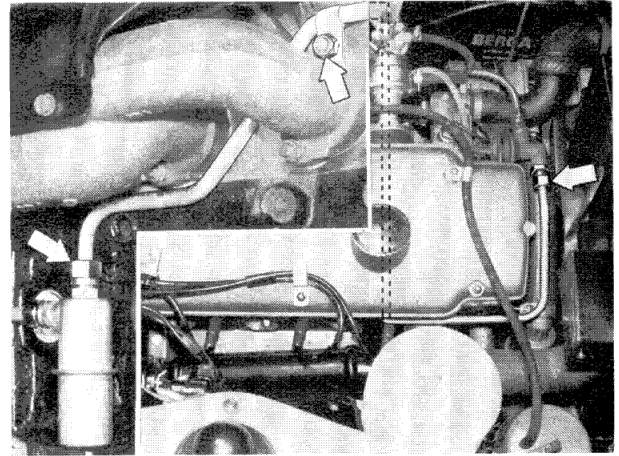

Remove exhaust gas recirculation pipe leading from cyclone filter to exhaust manifold.

Note when fitting: At engine idle speed, spray water on pipe connections. If this changes engine speed, check the connections for tightness and seal if necessary.

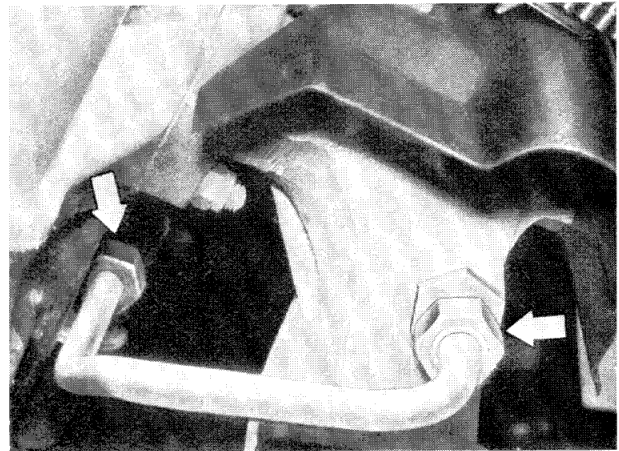

Replace cyclone filter every 56.000 miles (84.000 km).



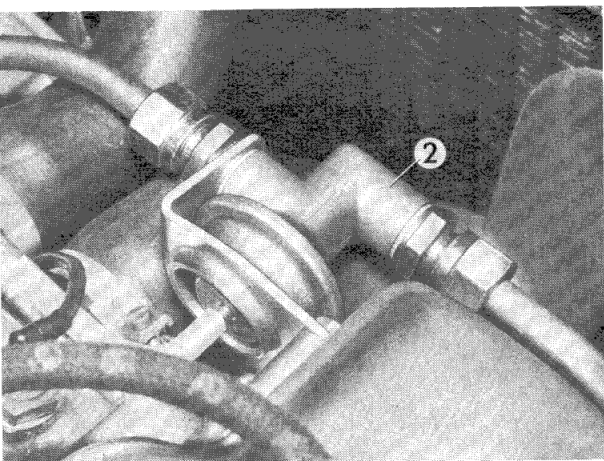

Replace diaphragm valve every 56.000 miles (84.000 km).

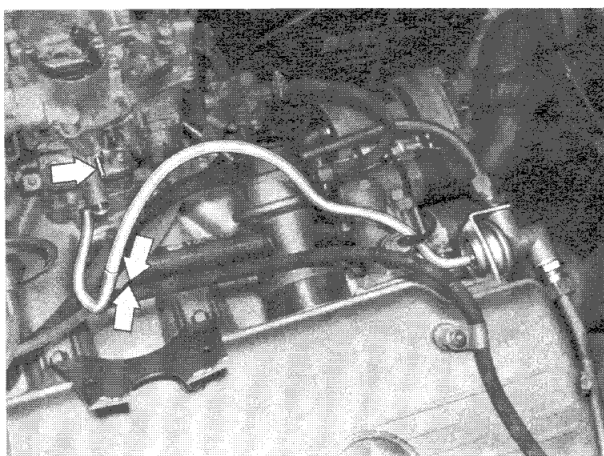

Check diaphragm valve for correct operation

Remove air filter cf. 13 71 000.

Set engine idle speed to 900 ± 50 rpm.

Pull vacuum control hose leading to diaphragm valve off carburettor and connect to vacuum hose for secondary crankcase vacuum control.

If the engine speed drops to approx. 500 - 600 rpm, the diaphragm valve is functioning correctly.

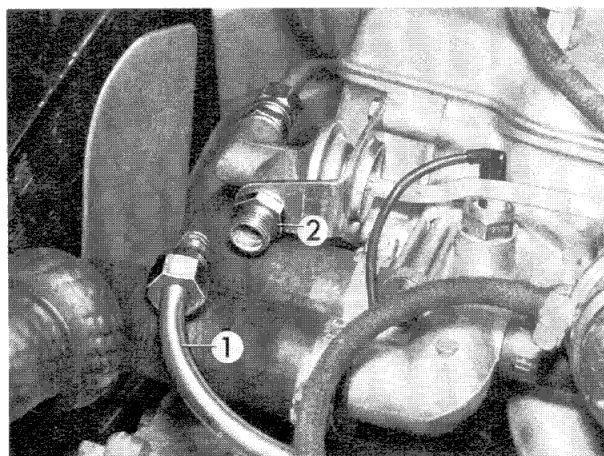

If engine speed drops only slightly, the recirculation pipes from the exhaust manifold to the intake pipe must be cleaned.

If this does not help, the diaphragm valve is defective. Detach recirculation pipe (1) from the diaphragm valve and plug.

Unscrew nut (2).

Increase engine speed to approx. $2500 \div 3000$ rpm.

This must open the plunger in the diaphragm valve (visual check).

If plunger does not open, replace diaphragm valve.

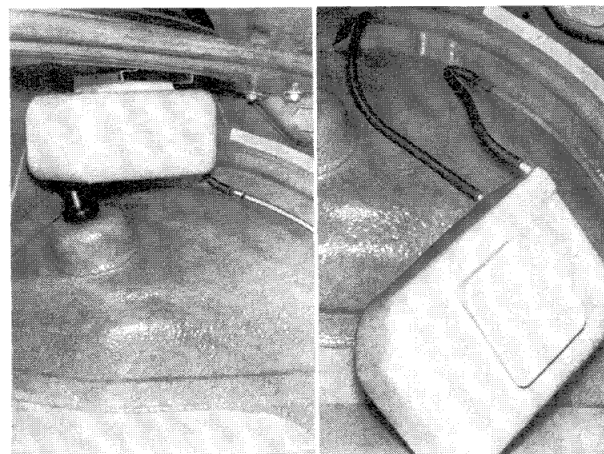

Evaporative control system

The maintenance-free vapour storage tank is located under the parcel shelf.



The maintenance-free activated carbon filter is mounted on the front right-hand wheel arch.

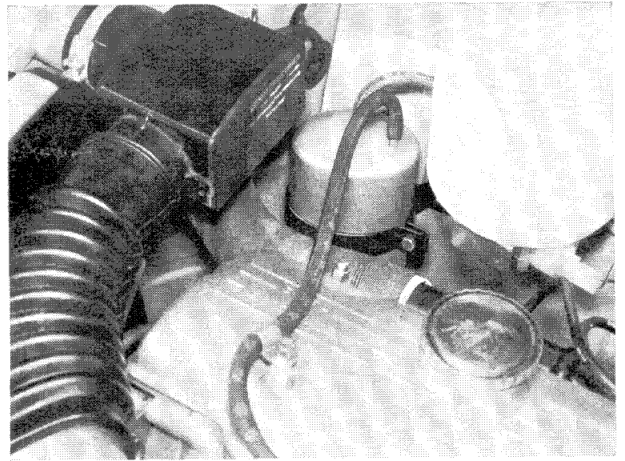

11 81 001 Replacement of right-hand engine support

Drain coolant.

Remove hose from bottom of radiator.

Note when fitting: Bleeding of coolant system cf. 11 53 000.

Pull air hose off distributor housing.

Loosen left-hand engine support.

Unscrew all bolts on the right-hand engine support.

Using hoist 600, lift up engine.

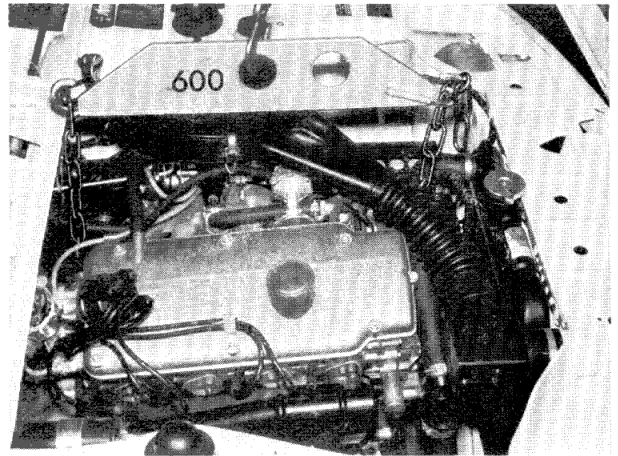

Remove engine support.

Note when fitting: Screw engine support onto front axle support, but do not tighten bolts. Adjust clearance A to 3 mm (0.1181").

Note position of safety catch in support member.

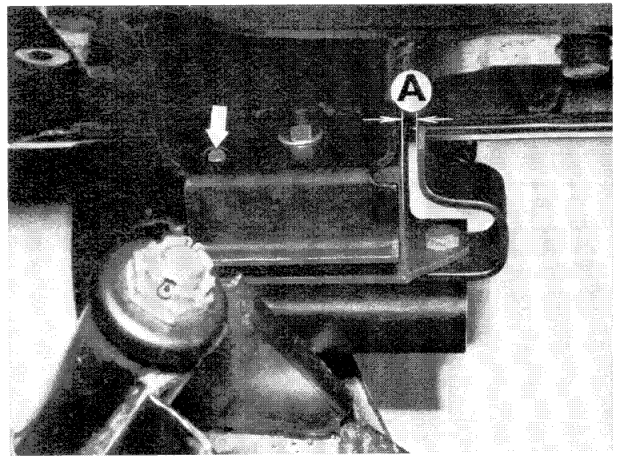

11 81 011 Replacement of left-hand engine support

Unscrew fastening nuts on engine support.

Using hoist 600, lift up engine slightly.

Remove engine support.

Note when fitting: The open end of the stop bush must face towards the wheel arch.

Note correct position of safety catch in the support member and the front axle support.

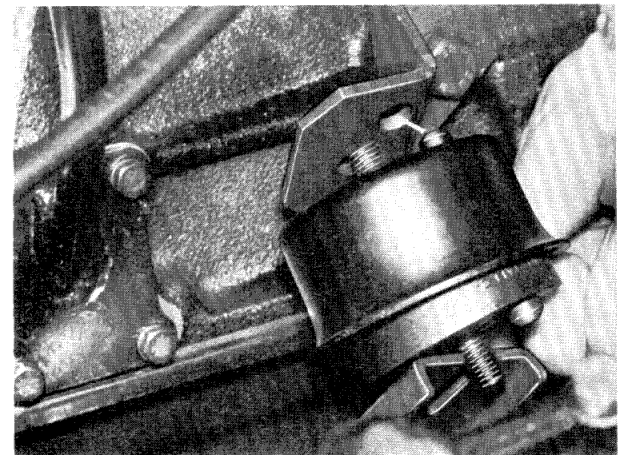

Thanks to the rectangular engine support, the air filter is not able to hit against the engine compartment lid.

Whenever necessary, the round engine support can be replaced by the rectangular one.

