

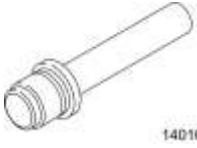









Motor

Speciaal Gereedschap / Algemene Uitrusting

 14010	204-017 Gereedschap om buitenste lagerring wielnaaf aan te brengen
 E117871	303-1473 Mounting Plate, Engine
 E121926	303-1521 Richtgereedschap, krukaspositiesensor
 E133912	303-1565 Richtgereedschap, nokkenas
 E161641	303-1626 Hijsogen, hoogspanningsaccu
 21135	303-254 Gereedschap om vliegwiel te vergrendelen
 E252718	303-435 Montagestandaard
 IA21213	303-509 Demontagegereedschap, trillingsdempersnaaf

	303-748 Borggereedschap, krukas
	310-128 Gereedschapsset om teflon afdichting aan te brengen
Hefbeugel	
Vloerkraan	
Gereedschap uitlijning koppeling	
Kunststof schraper	
Demontage-/montagegereedschap slangklemmen	
Stalen liniaal met rond uiteinde	

Materialen

Onderdeel	Specificatie
Wij raden aan: Ford-Castrol Magnatec	WSS-M2C948-B
Primer H-BW CU7J-BNDRT-AA/CA	-
Wij raden aan: Ford-Castrol Magnatec	WSS-M2C913-D
Siliconenkit LB NU7J-M4G323-AB	WSE-M4G323-A4
Oppervlakte-afdichtmiddel - anaeroob LR-2 2U7J-M2G348-BA	WSK-M2G348-A5
Koelvloeistof Super Plus Premium FU7J-19544-xx	WSS-M97B44-D

N.B.: Indien een nieuwe kettingspanner moet worden aangebracht, moet de gietijzeren kettingspanner worden vervangen door een aluminium kettingspanner (6K254). De bestaande bouten moeten worden weggegooid en vervangen door nieuwe bouten (6K282).

6-traps handgeschakelde versnellingsbak - MT82, Automatische transmissie met 10 versnellingen - 10R80:

1. Koppel:

Fase 1: 10 Nm

Fase 2: 20 Nm

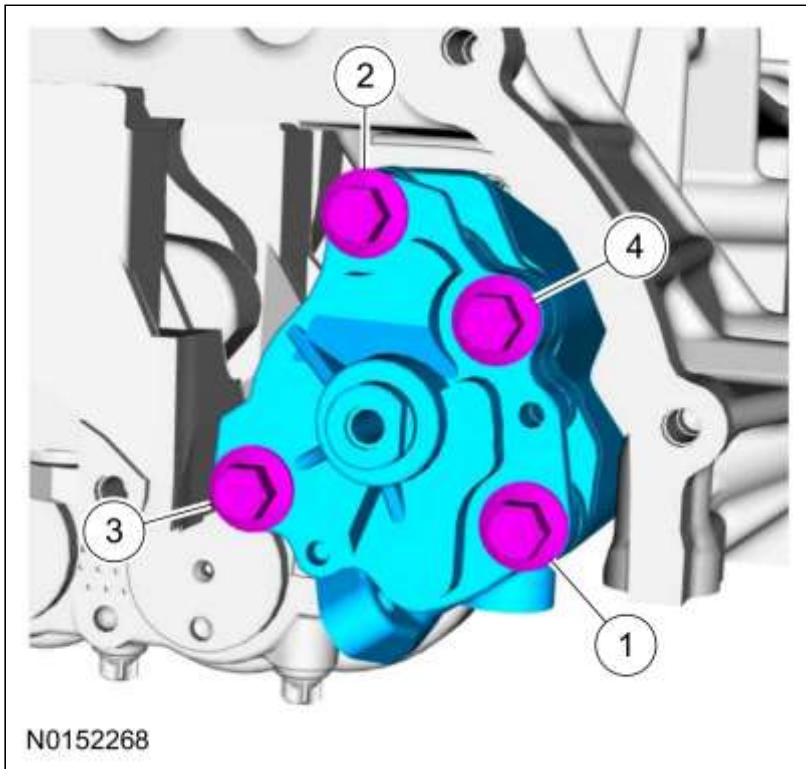

2. Koppel: 25 Nm

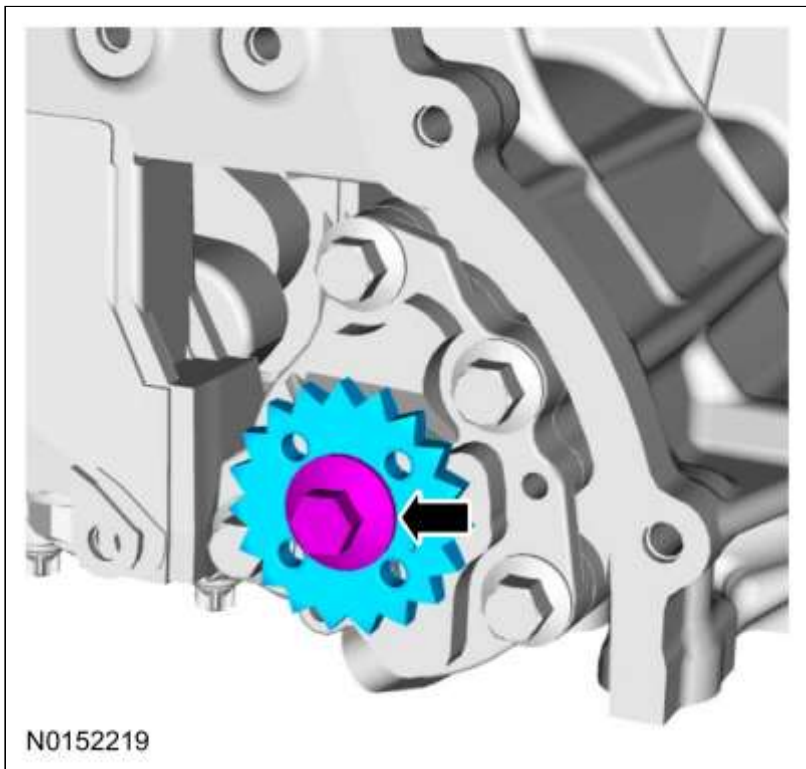

3.



4. 1. Koppel: 10 Nm

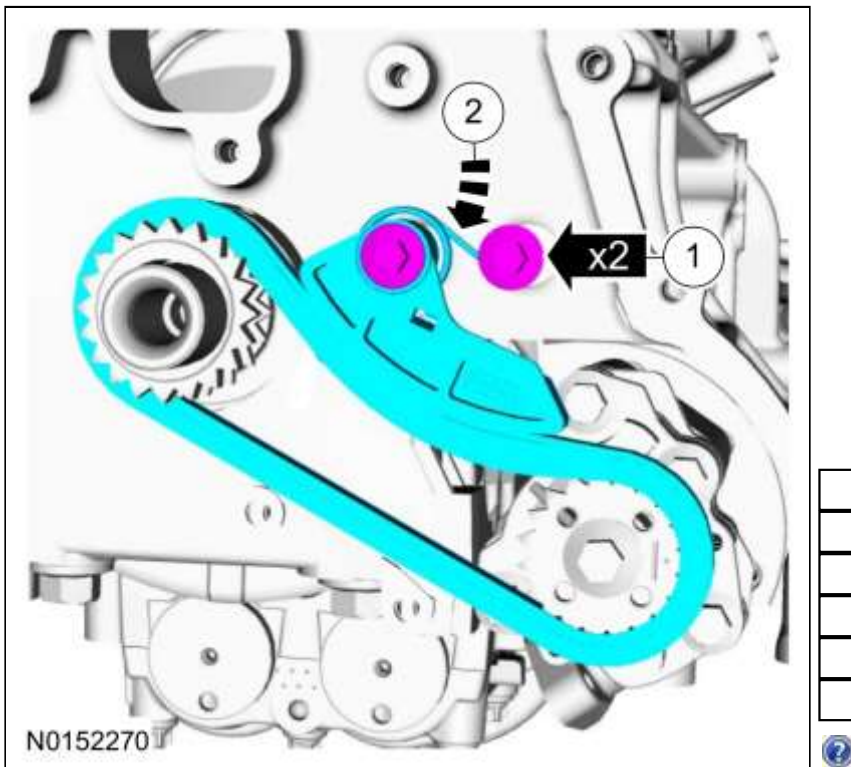

5. **N.B.:** Zorg dat de pasvlakken schoon en vrij van verontreinigingen zijn.

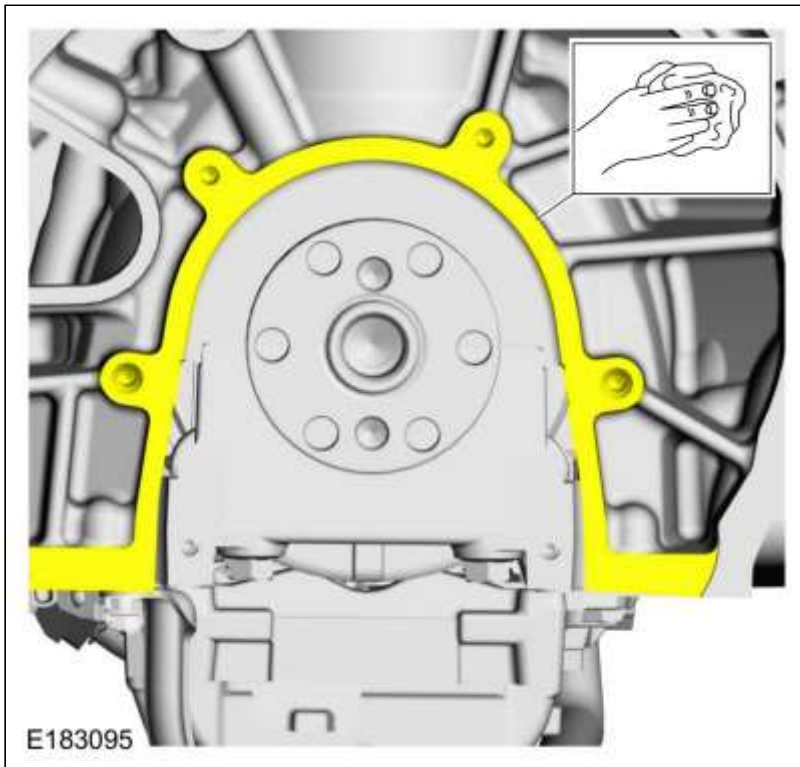

6. **N.B.:** Zorg dat een nieuw onderdeel wordt aangebracht.

N.B.: Nieuwe achterste krukaskeerringhouders worden met een centreerbus geleverd, die na het aanbrengen moet worden verwijderd.

Koppel: 10 Nm

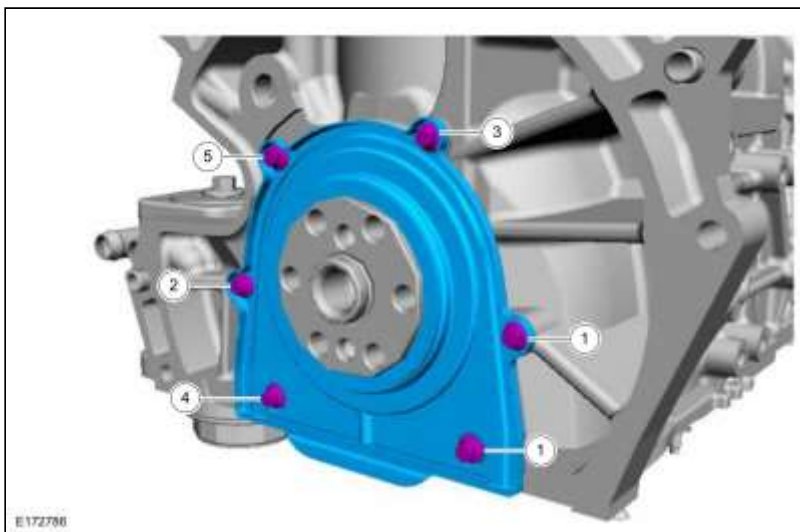

7.

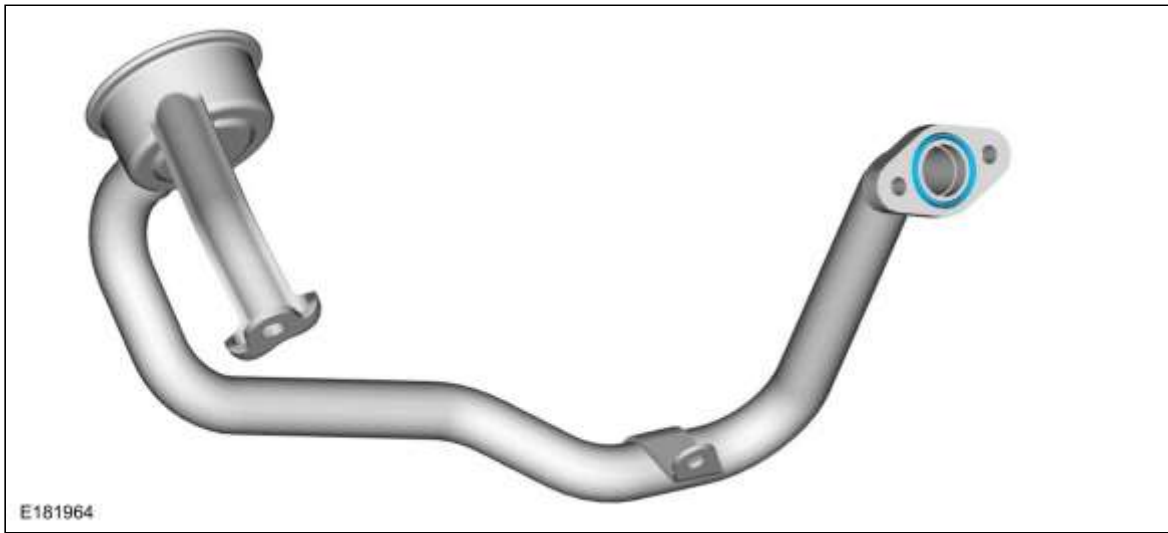

8. Koppel: 10 Nm

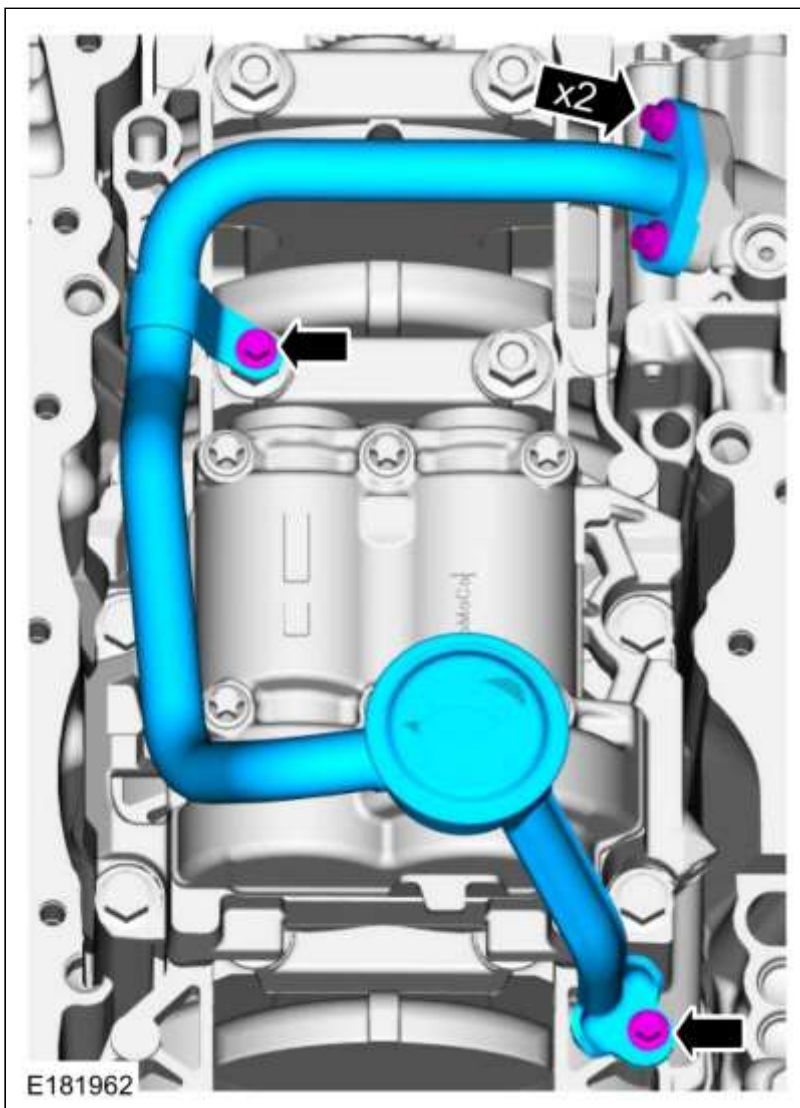

9. Algemene Uitrusting: Kunststof schraper
 Materialen: Primer H-BW / CU7J-BNDRT-AA/CA

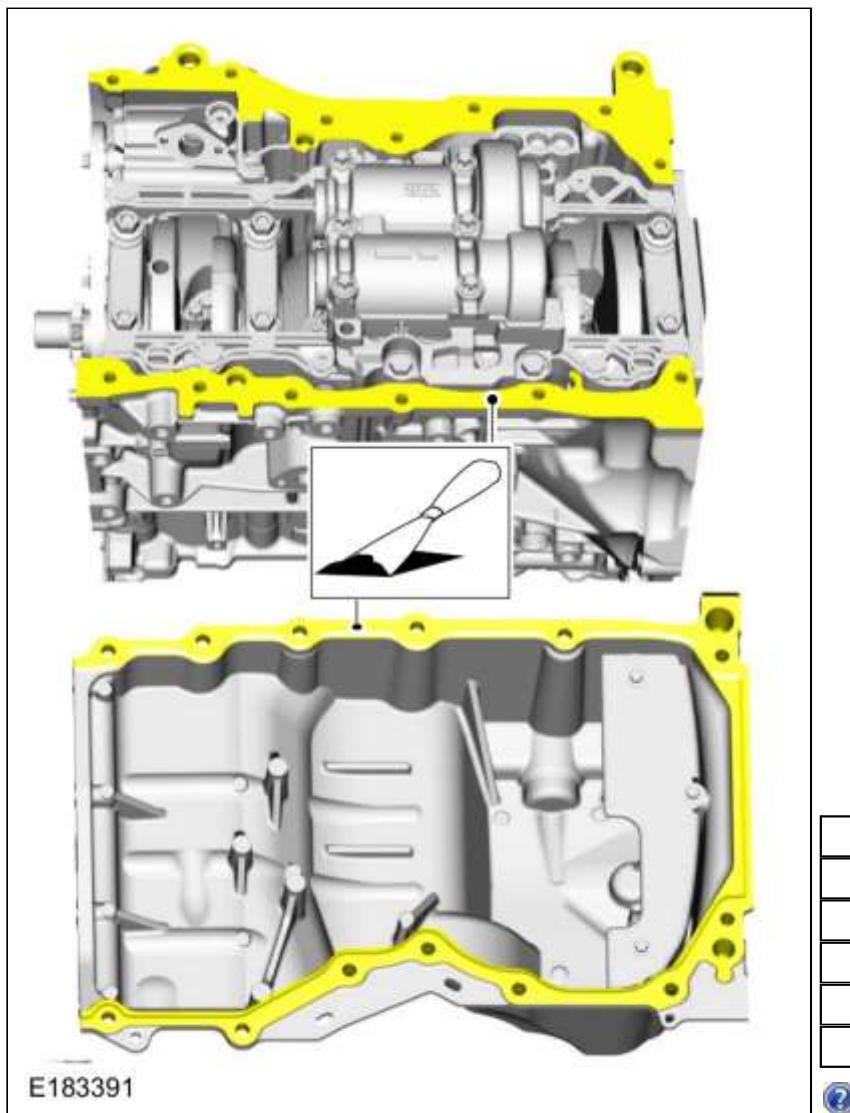

10. **N.B.:** Zorg dat de pasvlakken schoon en vrij van verontreinigingen zijn.

N.B.: Het onderdeel moet binnen 10 minuten na het aanbrengen van het afdichtmiddel worden aangebracht.

Materialen: Siliconenkit LB / NU7J-M4G323-AB (WSE-M4G323-A4)

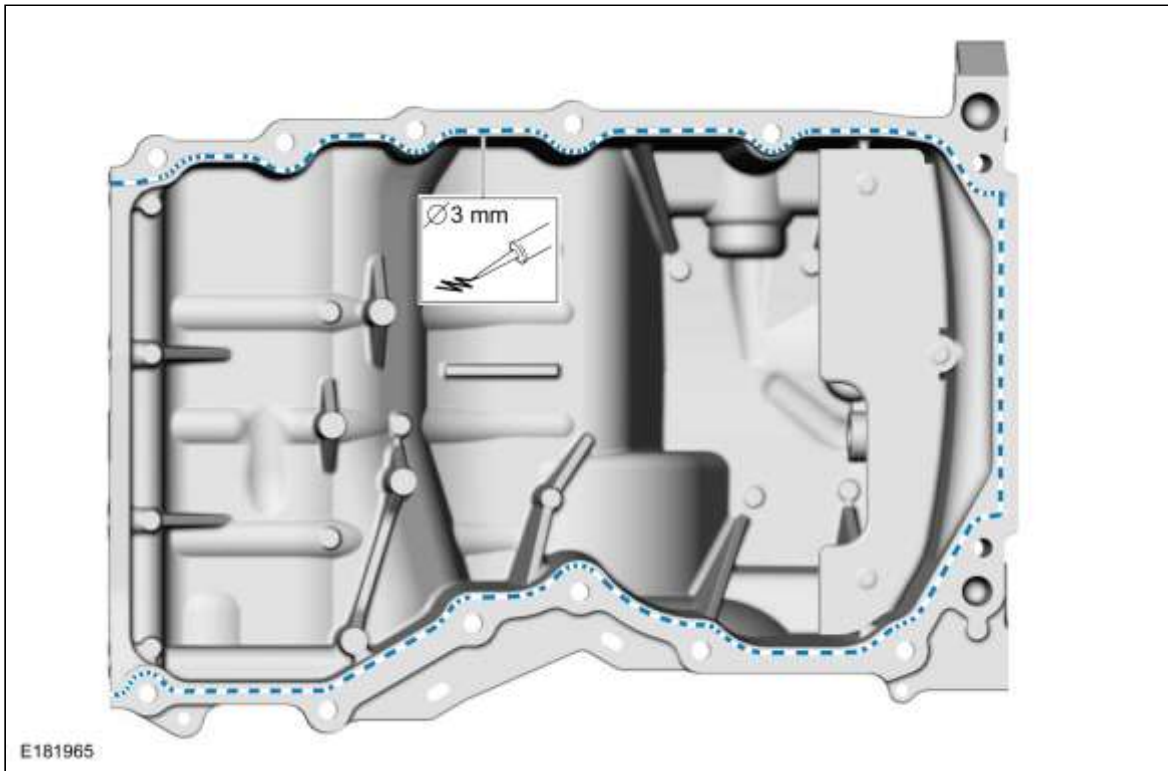

11. **N.B.:** Haal alle bouten handvast aan alvorens ze op aanhaalmoment aan te halen.

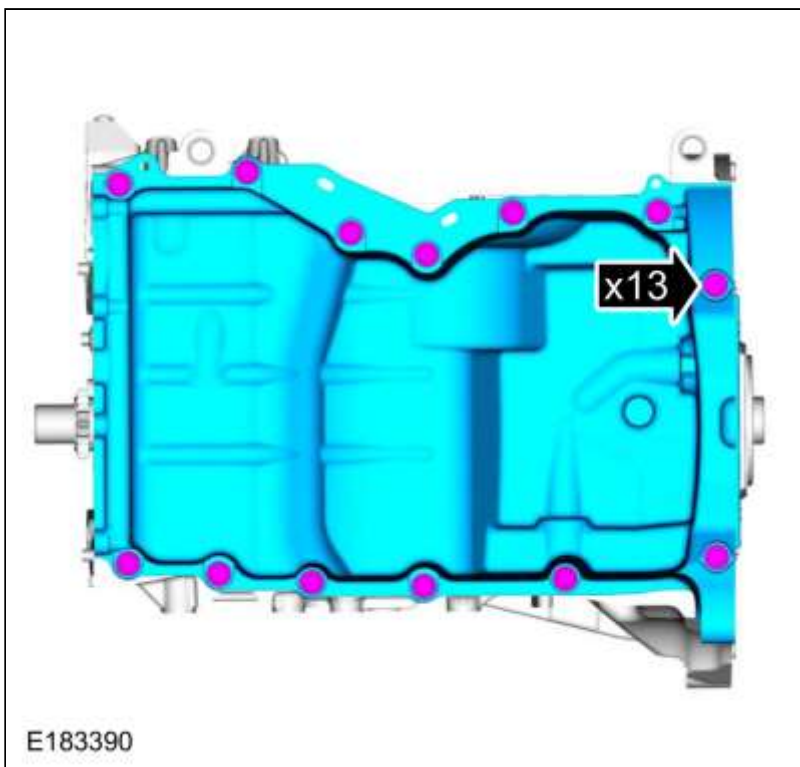

12. Algemene Uitrusting: Stalen liniaal met rond uiteinde

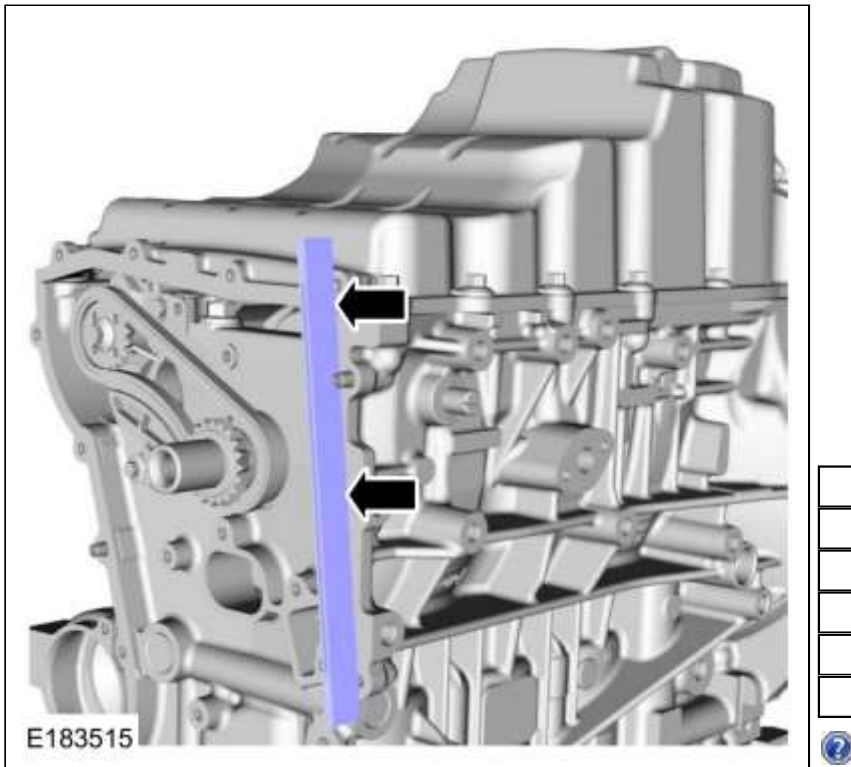

13. *Koppel:* 25 Nm

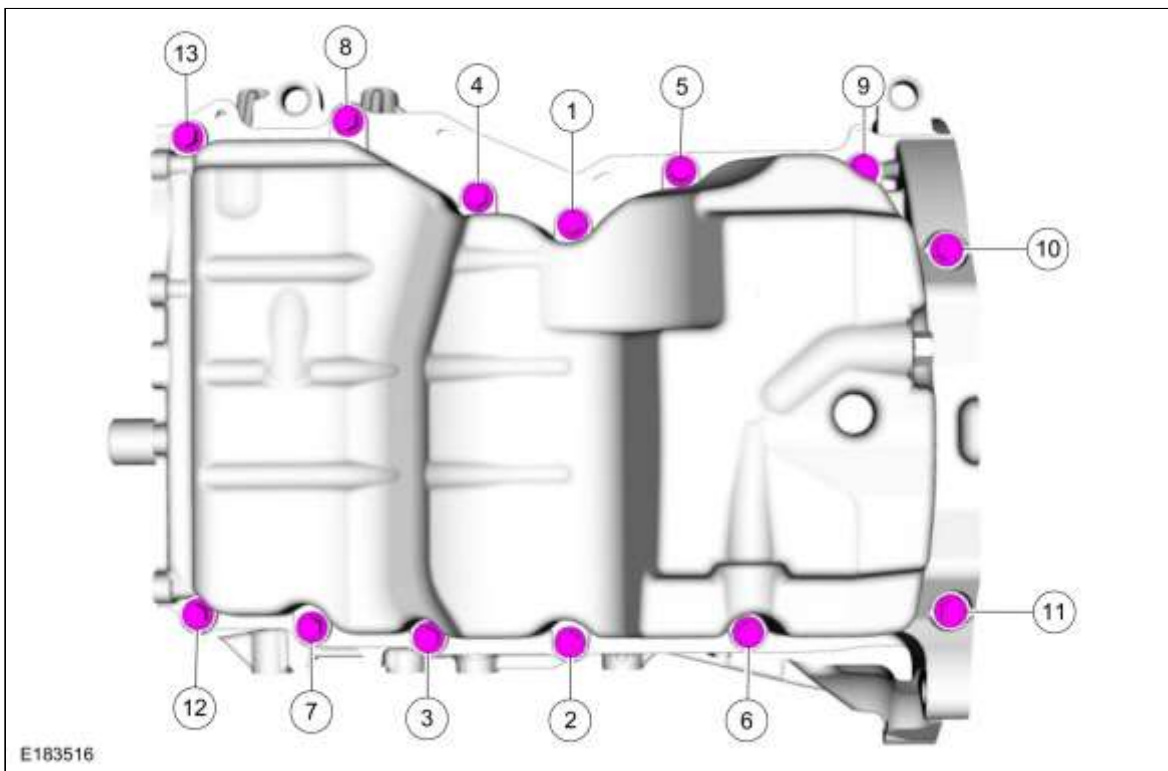

14. **KENNISGEVING:** Draai de krukas uitsluitend rechtsom.

Draai de krukas tot zuiger nr. 1 ongeveer 20 mm vóór het bovenste dode punt (BDP) staat.

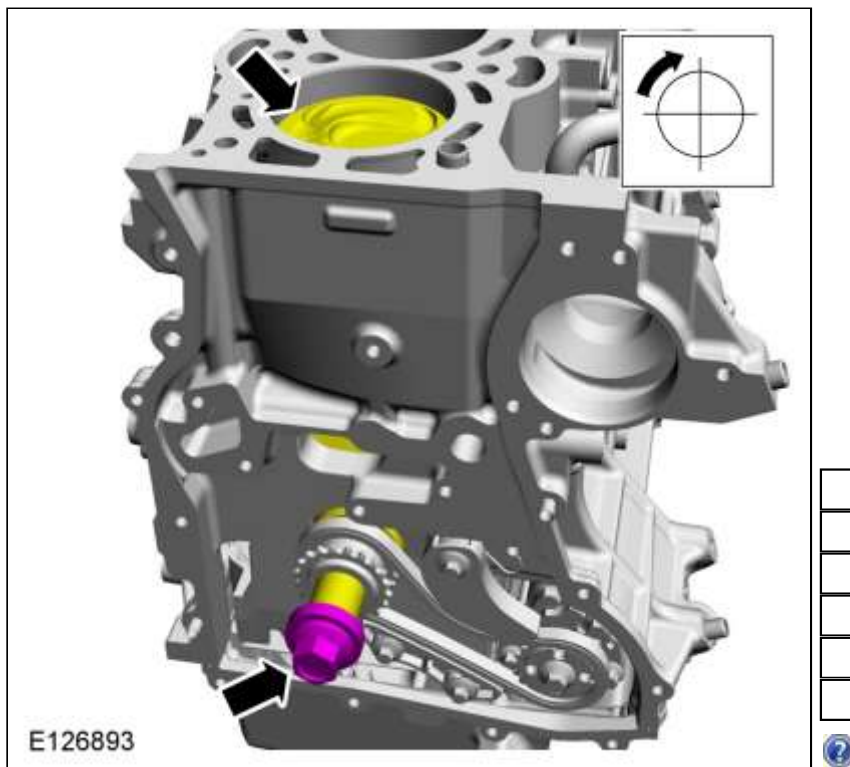

15. **N.B.:** Zorg dat nieuwe bouten worden gebruikt.

Koppel:

- Fase 1: 7 Nm
- Fase 2: 15 Nm
- Fase 3: 55 Nm
- Fase 4: 90°
- Fase 5: 90°

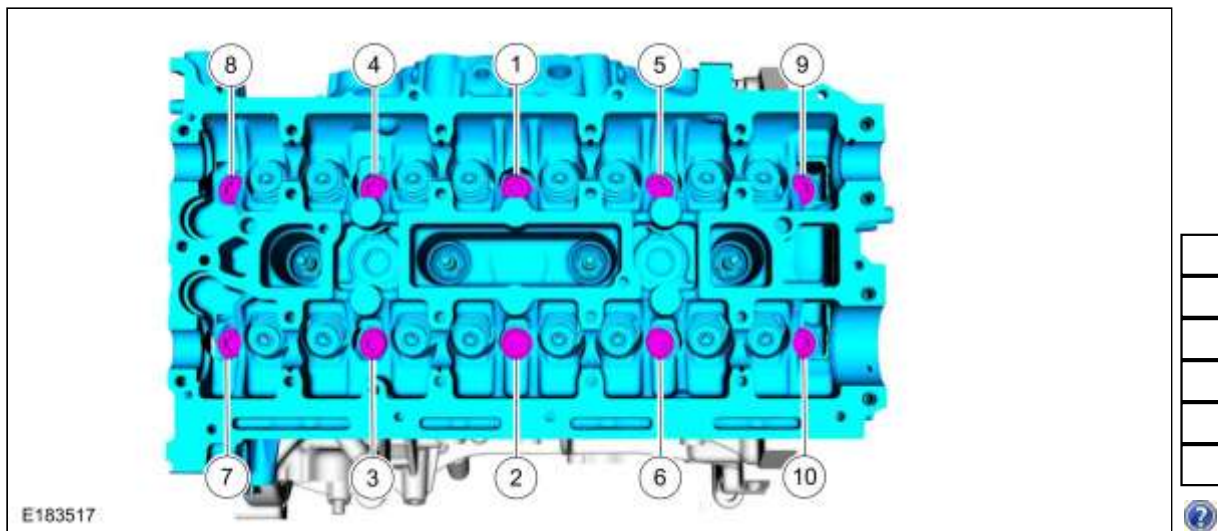

16. Zie: [Specificaties](#) (303-01B Motor - 2.3L EcoBoost (231kW/314pk)/2.3L EcoBoost (257kW/350pk) – MI4, Auto's geproduceerd tot: 1-november-2017, Specificaties).

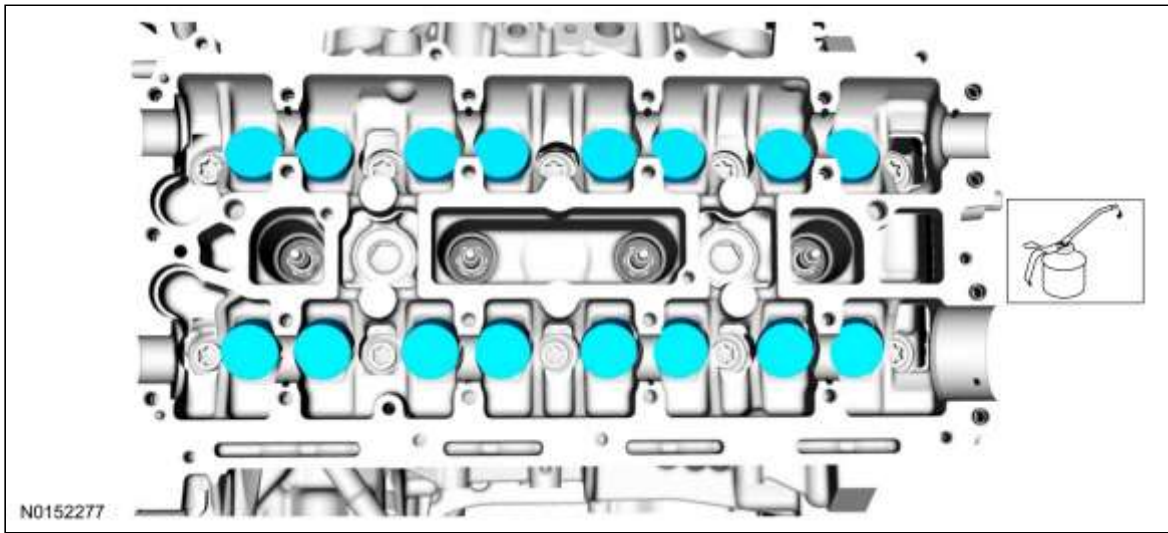

17. 2. Speciaal gereedschap aanbrengen: 303-748 Borggereedschap, krukas.

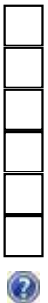
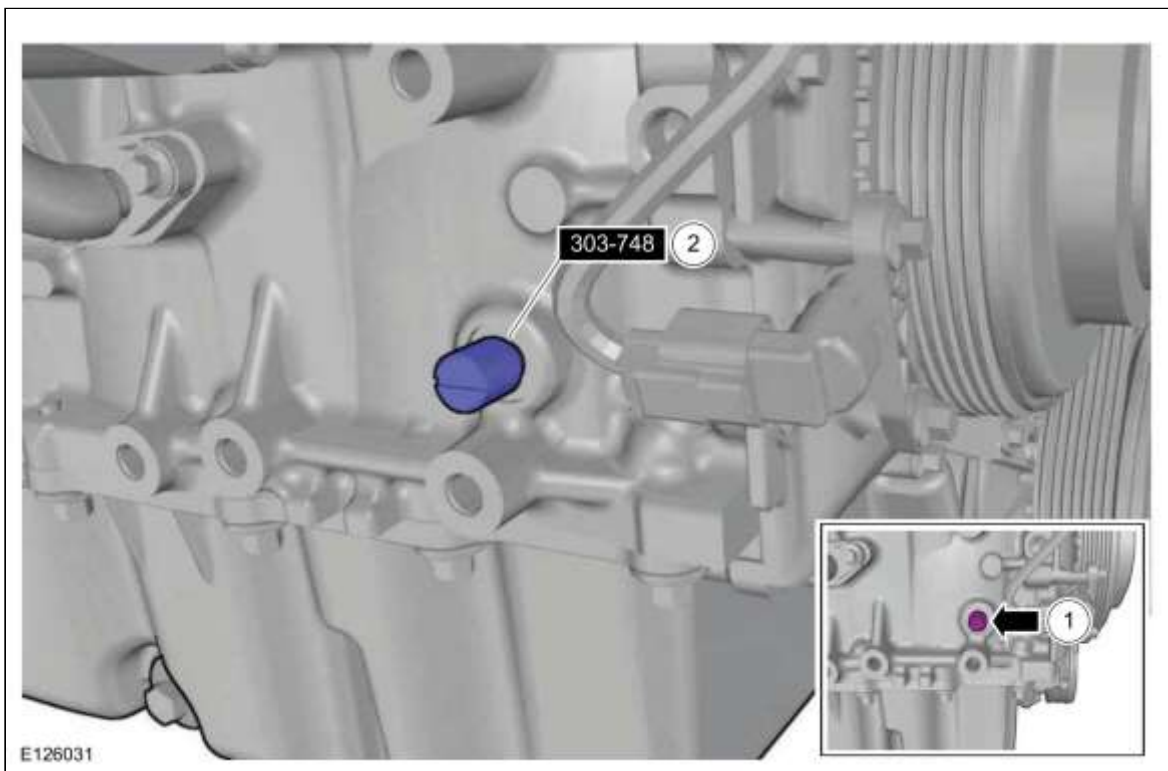

18.

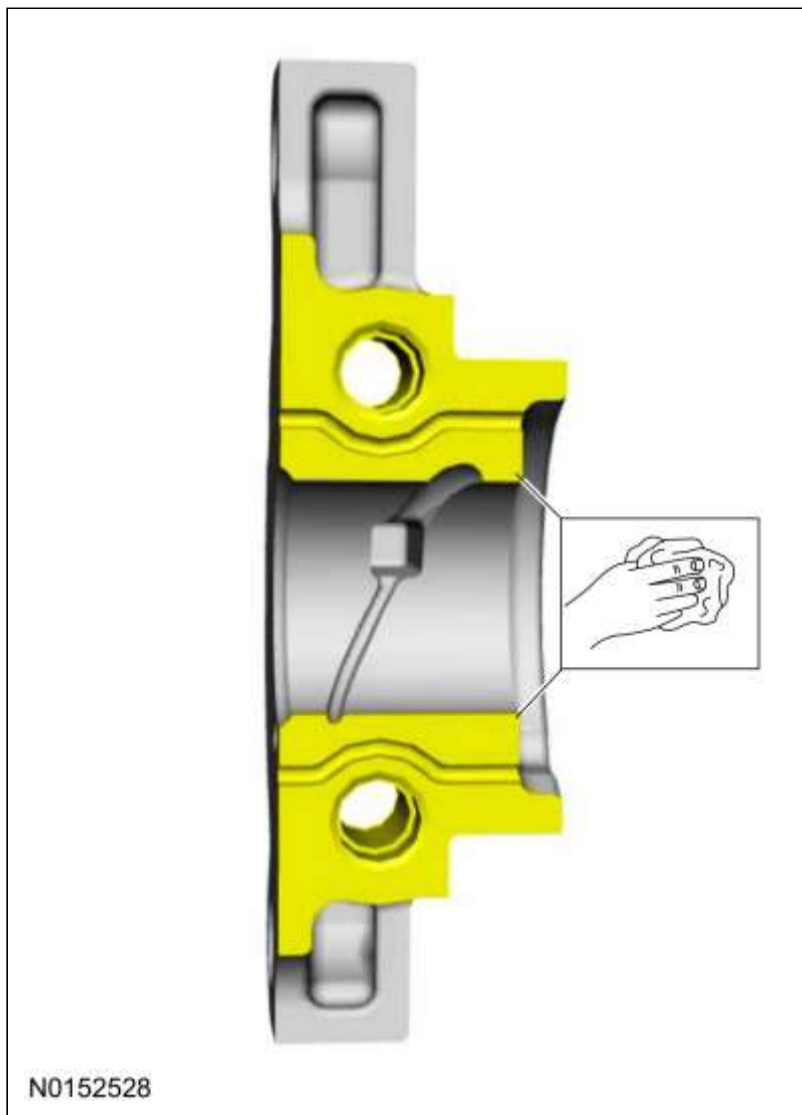

19. *Materialen:* Oppervlakte-afdichtmiddel - anaeroob LR-2 / 2U7J-M2G348-BA (WSK-M2G348-A5)
Materialen: Primer H-BW / CU7J-BNDRT-AA/CA

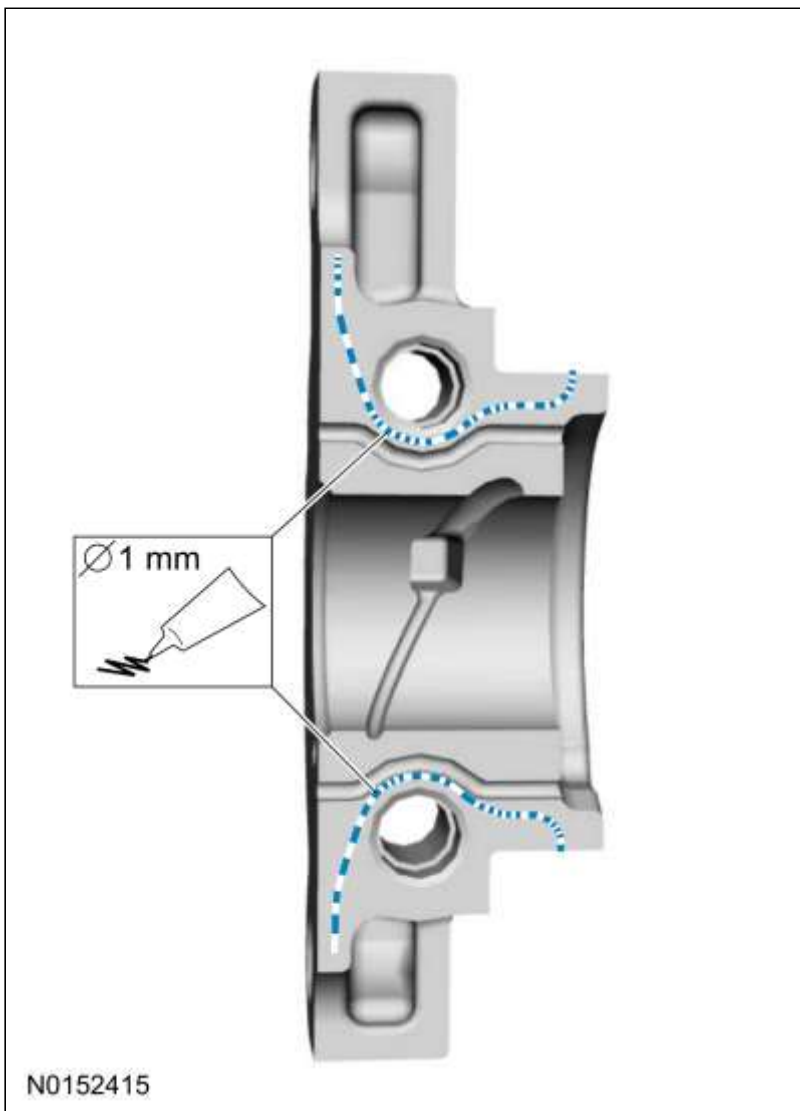

20. Haal elke bout telkens 2 slagen aan.

Koppel:

Fase 1: 7 Nm

Fase 2: 16 Nm

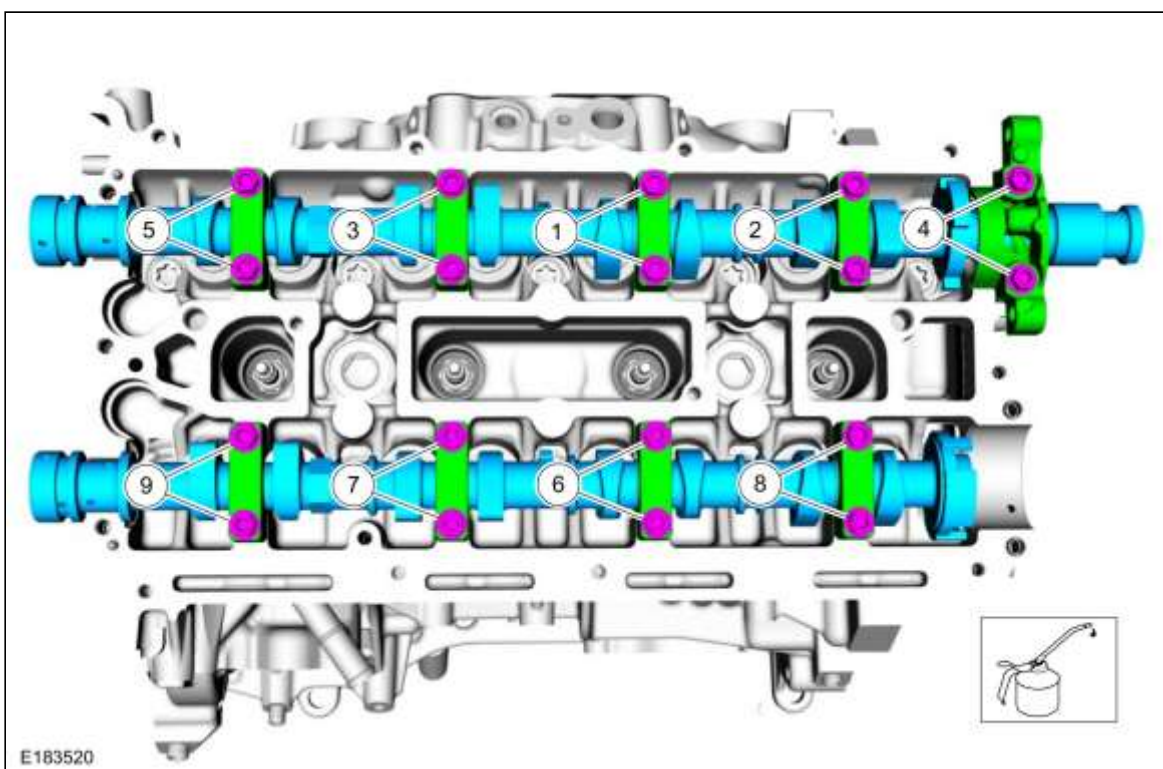

21. *Materialen:* Wij raden aan: Ford-Castrol Magnatec (WSS-M2C913-D)

Koppel:

Fase 1: 7 Nm

Fase 2: 16 Nm

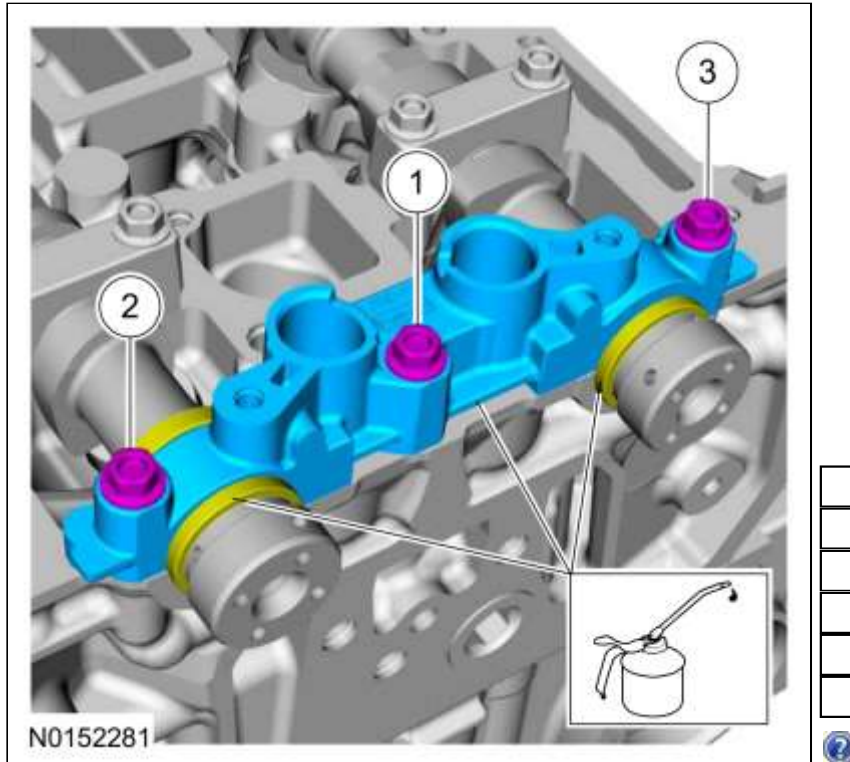

22. Zie: [Klepspeling afstellen](#) (303-01B Motor - 2.3L EcoBoost (231kW/314pk)/2.3L EcoBoost (257kW/350pk) – MI4, Auto's geproduceerd tot: 1-november-2017, Algemene procedures).

23. *Koppel:* 10 Nm

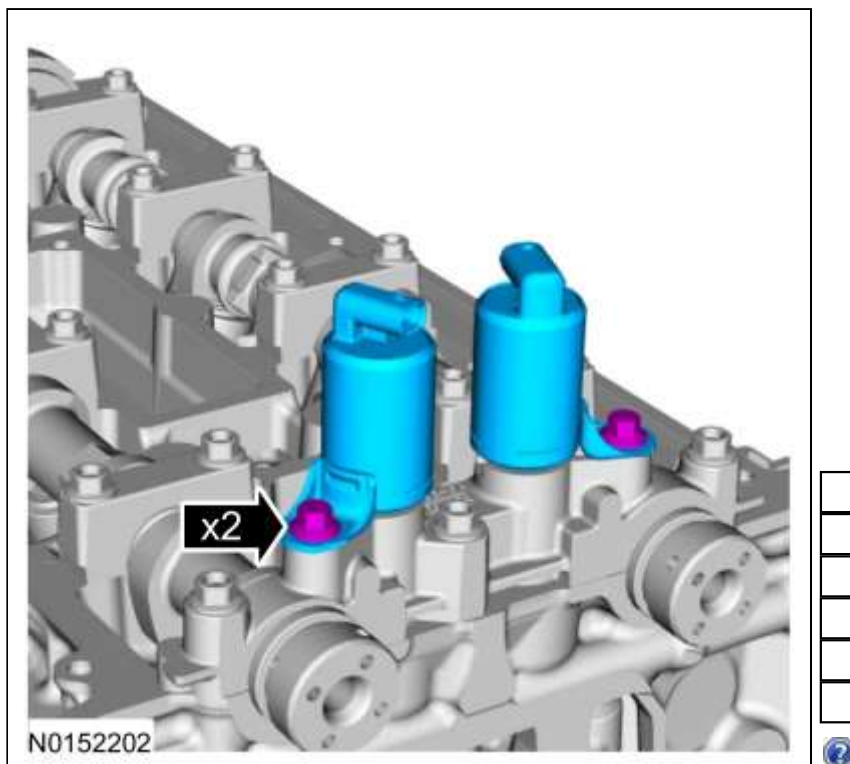

24. Speciaal gereedschap aanbrengen: 303-1565 Richtgereedschap, nokkenas.

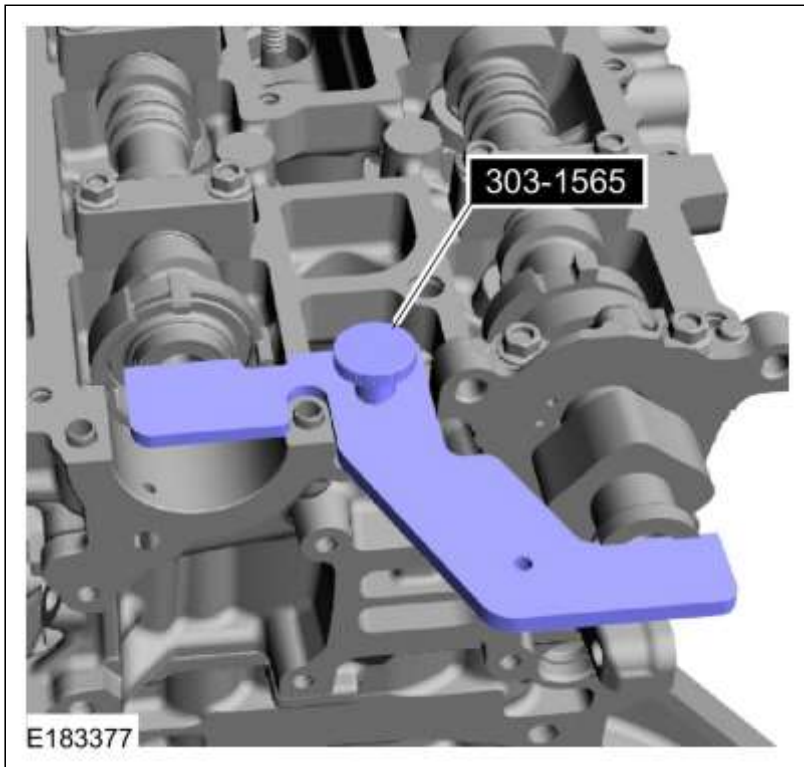

25. **N.B.:** Haal de bouten in deze fase uitsluitend handvast aan.

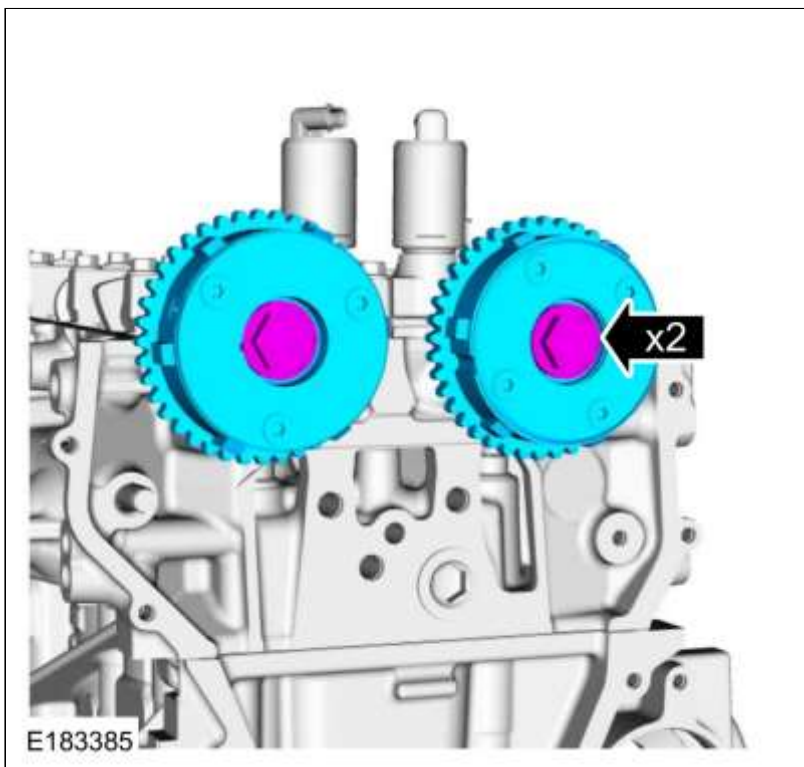

26. *Koppel:* 10 Nm

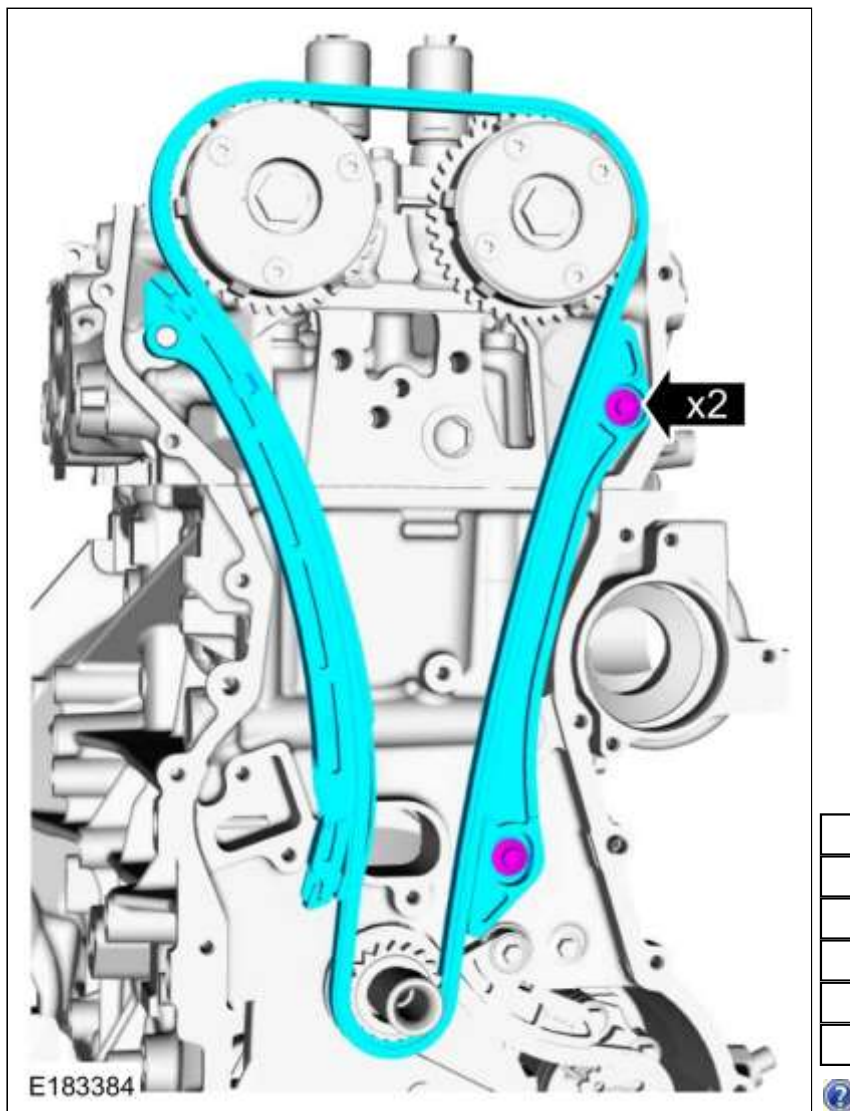

N.B.: Indien uitgerust met een aluminium kettingspanner.

N.B.: Volg de volgende stap indien de stoter van de kettingspanner niet met een pen in de samengedrukte positie wordt vastgehouden.

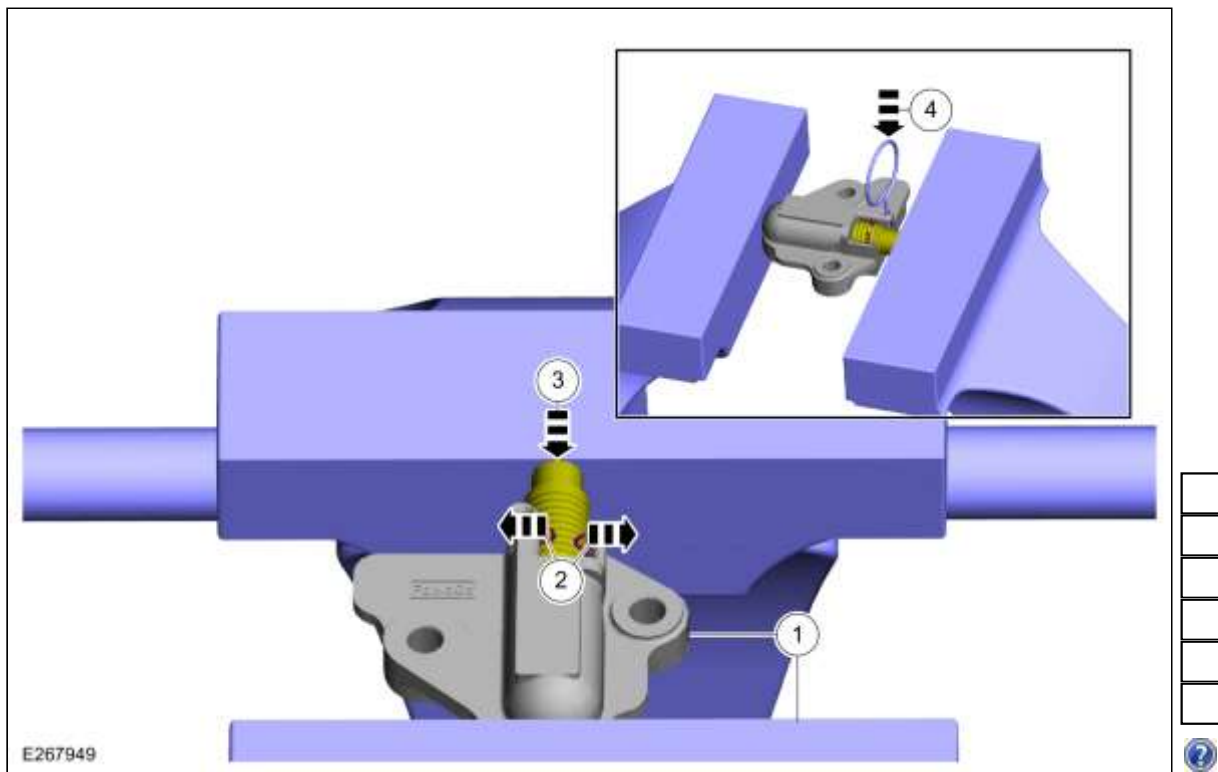

28. **⚠ WAARSCHUWING:** De spanner staat onder veerkracht. Ga voorzichtig met de spanner om. Het niet opvolgen van dit voorschrift kan tot ernstig persoonlijk letsel leiden.

N.B.: Indien uitgerust met een aluminium kettingspanner.

N.B.: Verwijder de borgpen pas wanneer de bouten van de kettingspanner zijn aangehaald.

1. Koppel: 10 Nm

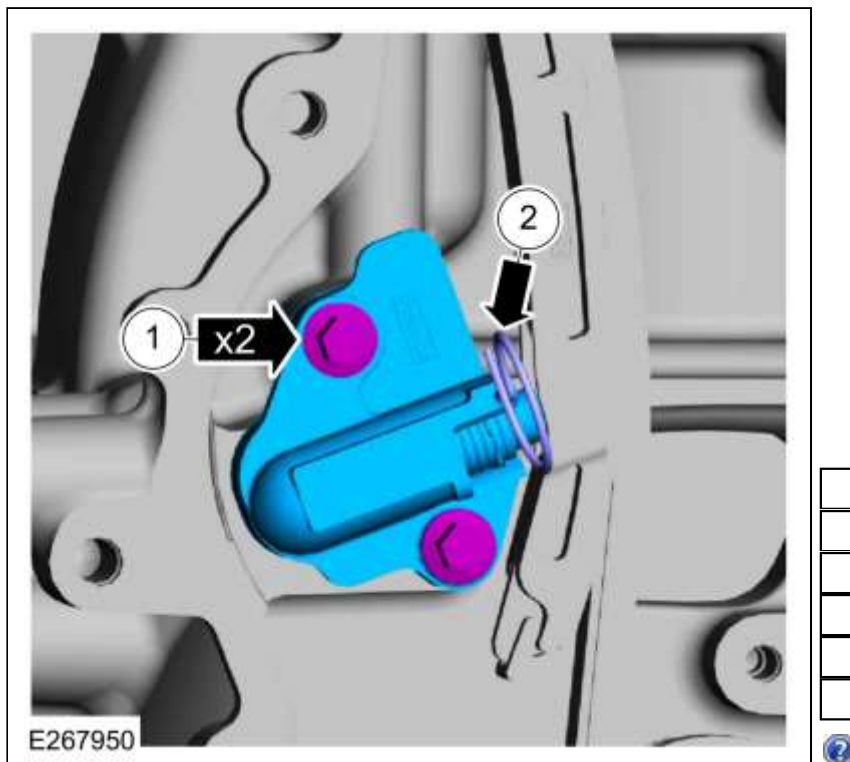

29. **⚠ WAARSCHUWING:** De spanner staat onder veerkracht. Ga voorzichtig met de spanner om. Het niet opvolgen van dit voorschrift kan tot ernstig persoonlijk letsel leiden.

N.B.: Indien uitgerust met een gietijzeren kettingspanner.

Koppel: 10 Nm

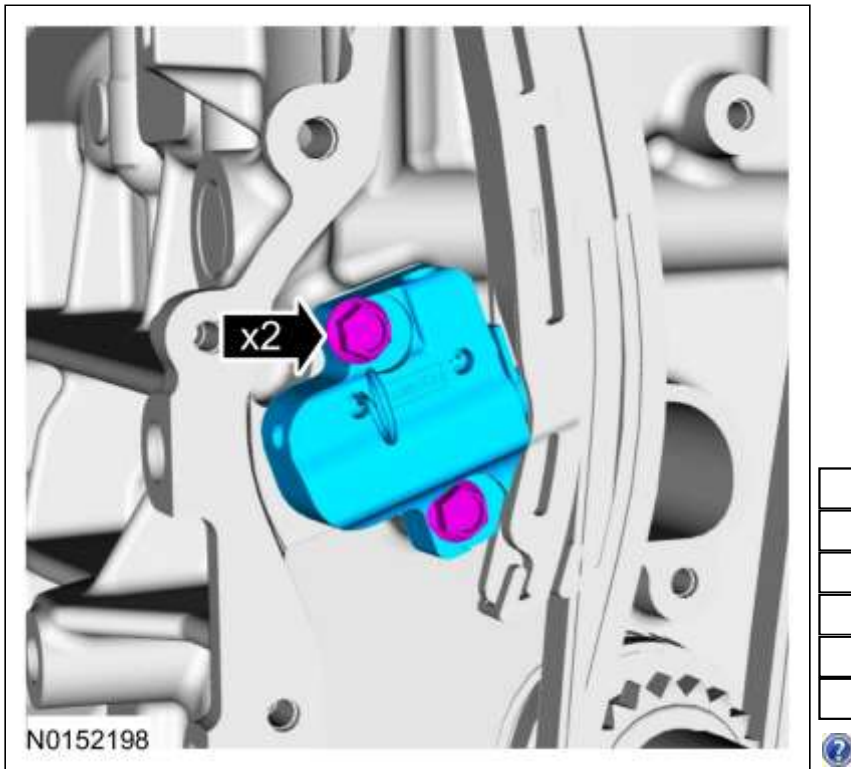

30. **N.B.:** Indien uitgerust met een gietijzeren kettingspanner.

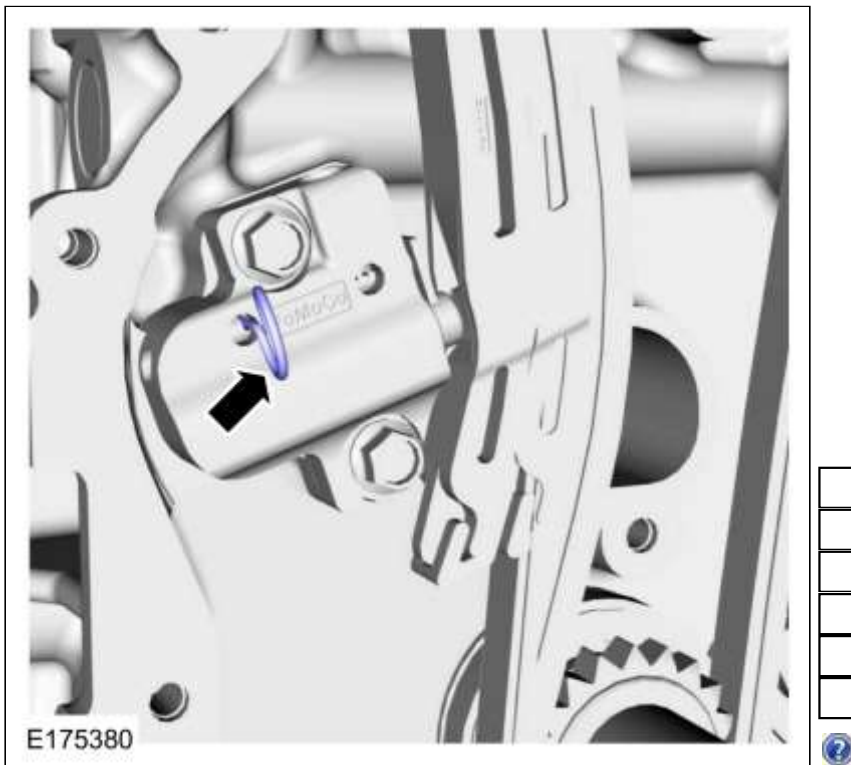

31. **KENNISGEVING:** Voorkom met een steeksleutel dat het onderdeel draait.

Koppel:

Fase 1: 40 Nm

Fase 2: 60°

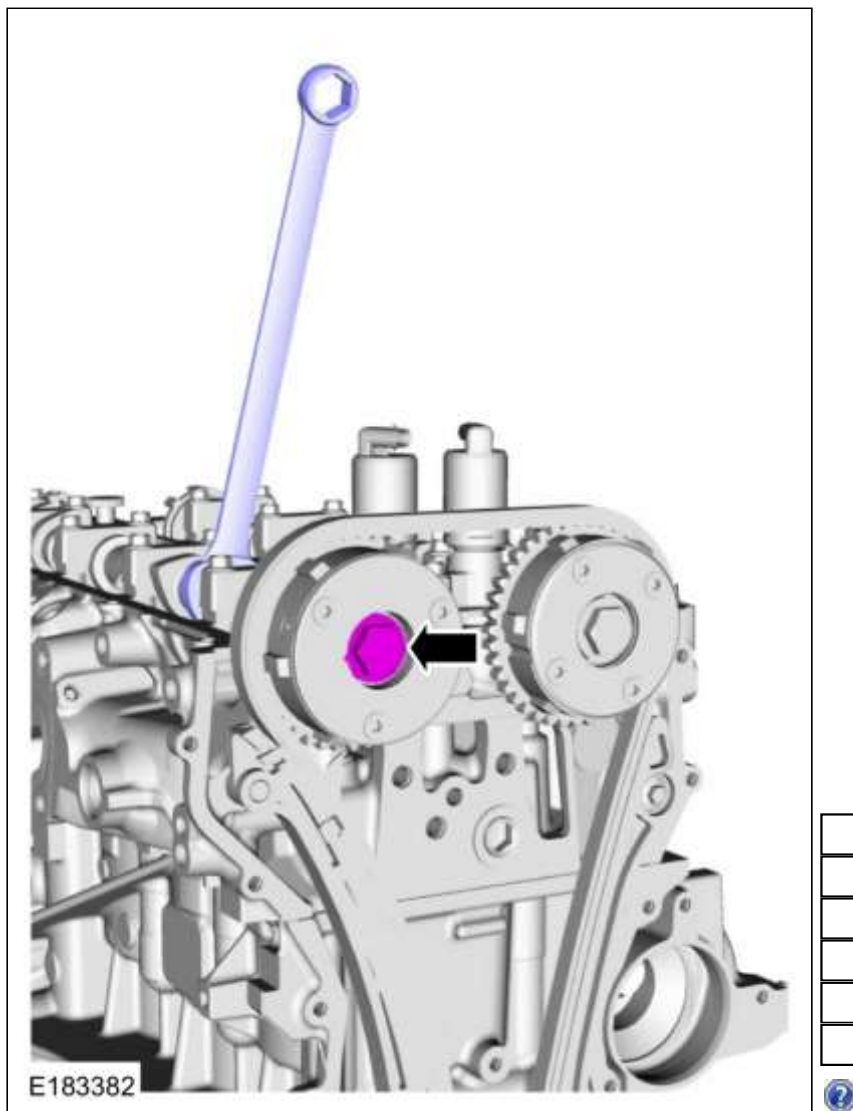

32. **KENNISGEVING:** Voorkom met een steeksleutel dat het onderdeel draait.

Koppel:

Fase 1: 40 Nm

Fase 2: 60°

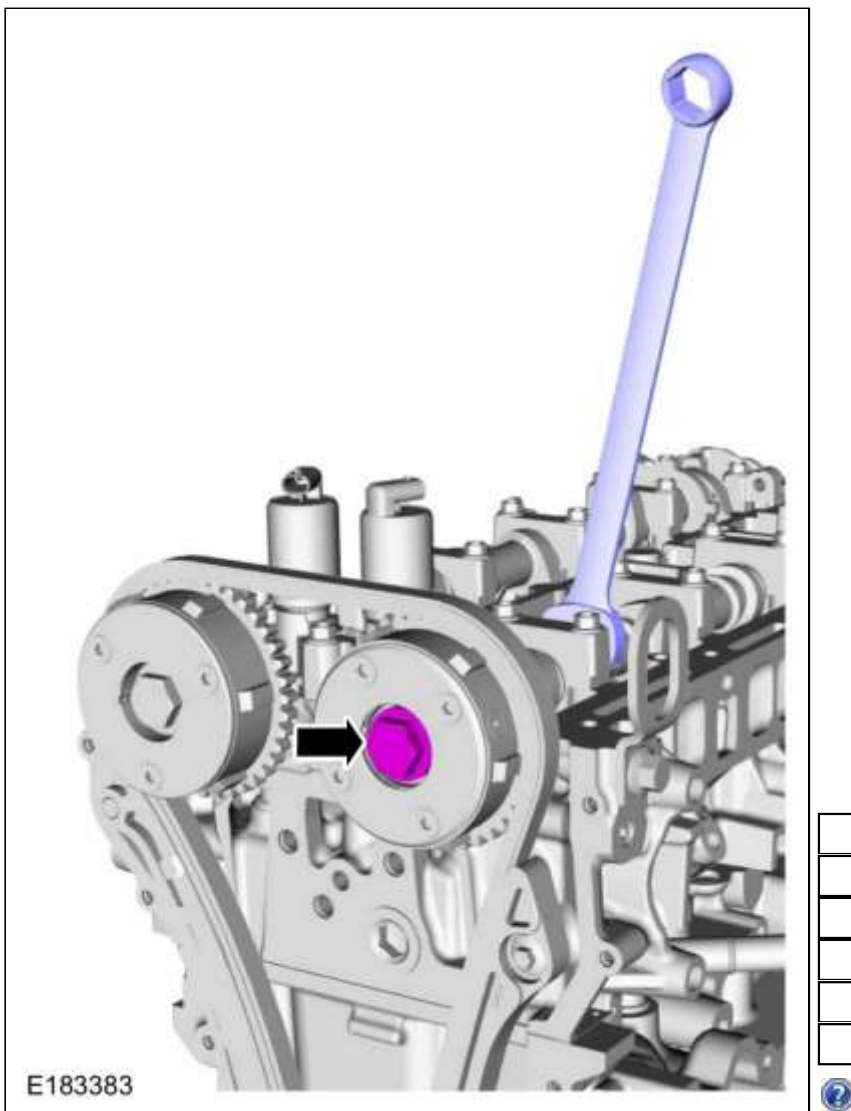

33. Algemene Uitrusting: Kunststof schraper
 Materialen: Primer H-BW / CU7J-BNDRT-AA/CA

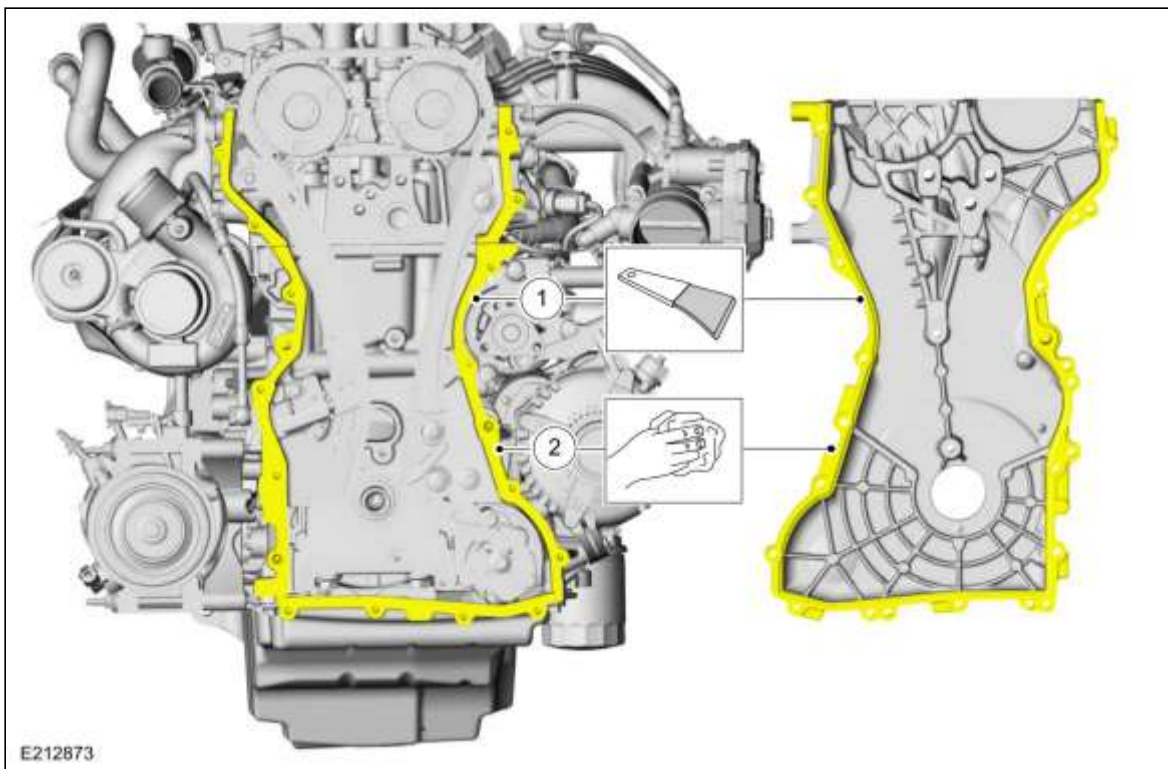

34. **N.B.:** Het onderdeel moet binnen 10 minuten na het aanbrengen van het afdichtmiddel worden aangebracht.

Materialen: Siliconenkit LB / NU7J-M4G323-AB (WSE-M4G323-A4)
Materialen: Primer H-BW / CU7J-BNDRT-AA/CA

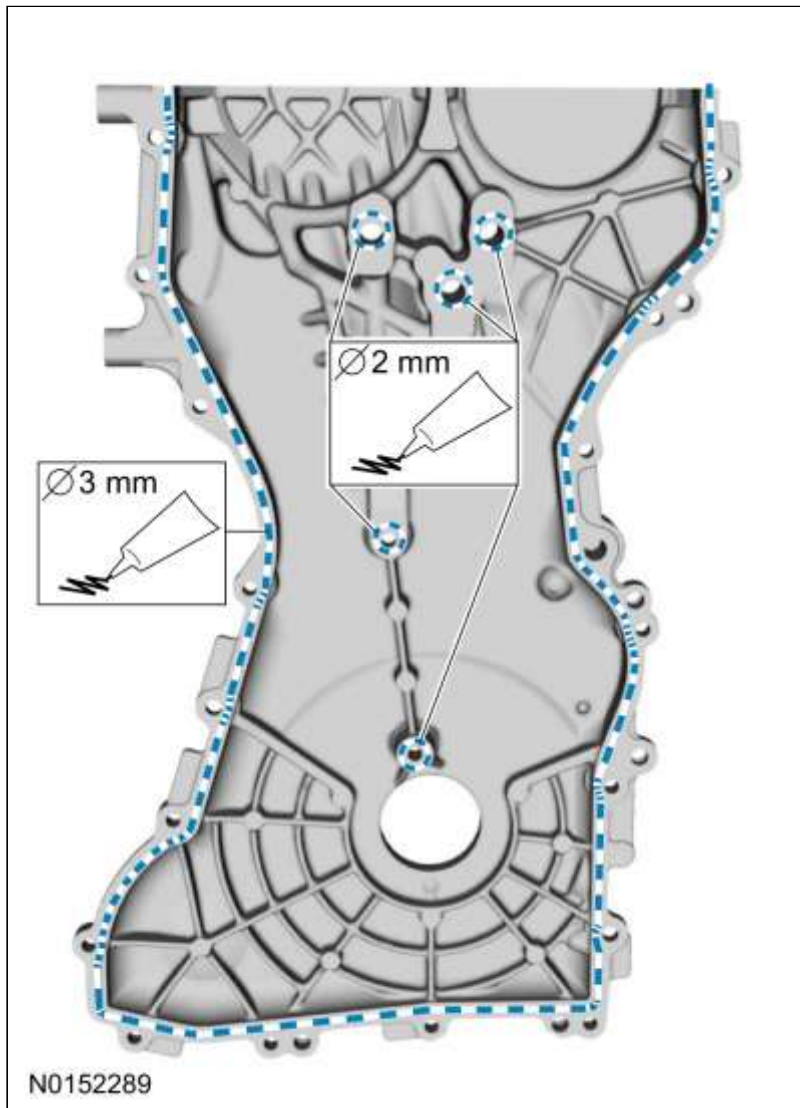

35. **N.B.:** Het onderdeel moet binnen 10 minuten na het aanbrengen van het afdichtmiddel worden aangebracht.

Materialen: Siliconenkit LB / NU7J-M4G323-AB (WSE-M4G323-A4)
Materialen: Primer H-BW / CU7J-BNDRT-AA/CA

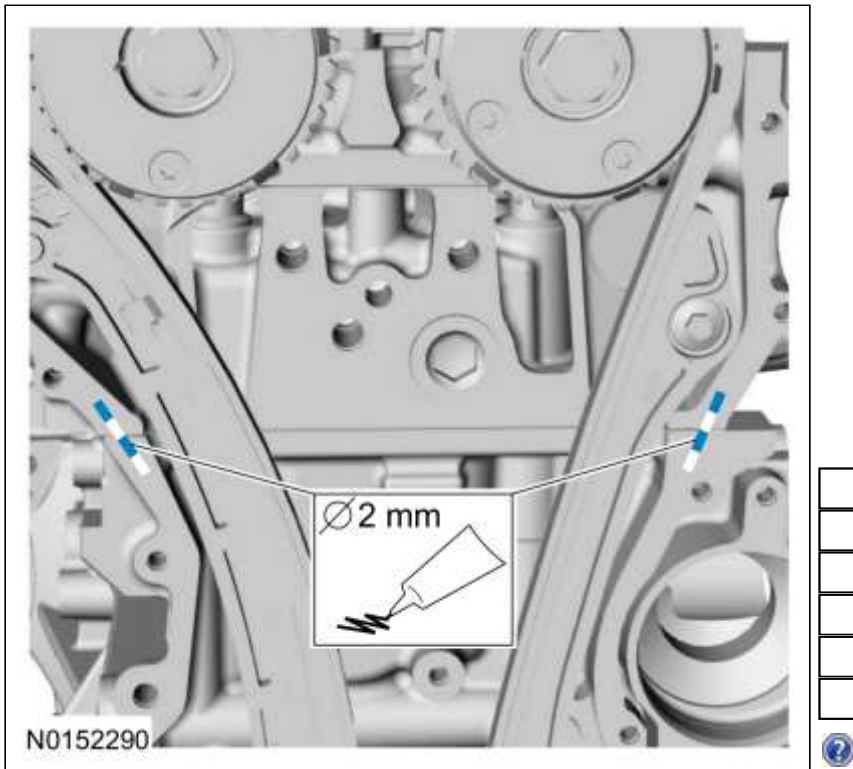

36. Koppel:

Bouten 1 - 3: 48 Nm

Bouten 4 - 22: 10 Nm

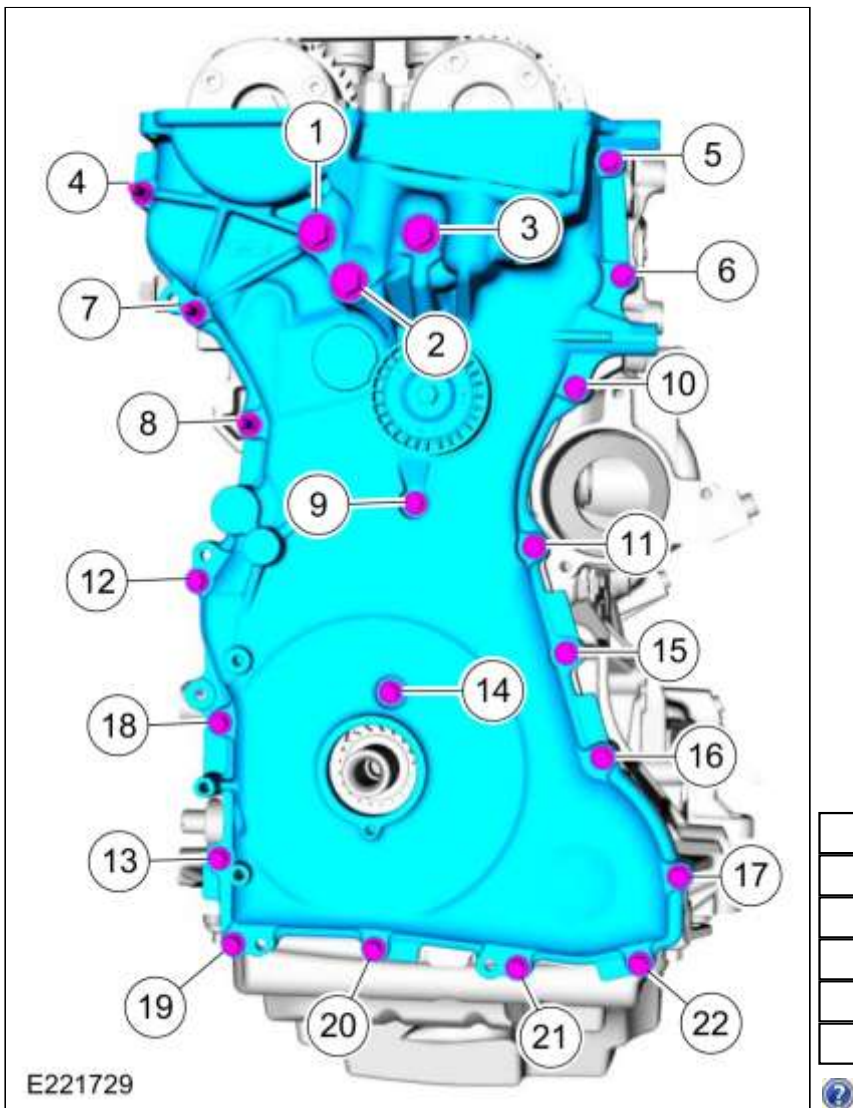

37. Speciaal servicegereedschap gebruiken: 303-509 Demontagereedschap, trillingsdempernaaf.

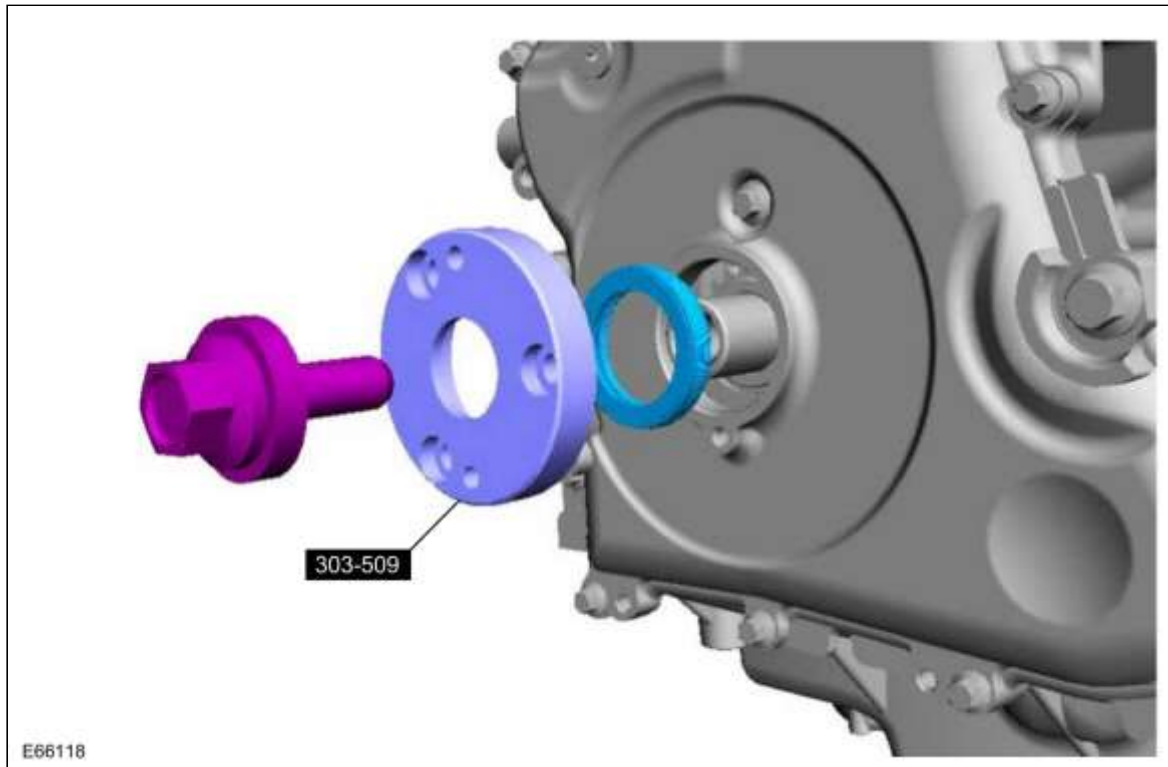

38. **KENNISGEVING:** Draai de krukas uitsluitend rechtsom.

Draai de krukas langzaam rond tot deze stopt.

Speciaal servicegereedschap gebruiken: 303-748 Borggereedschap, krukas.

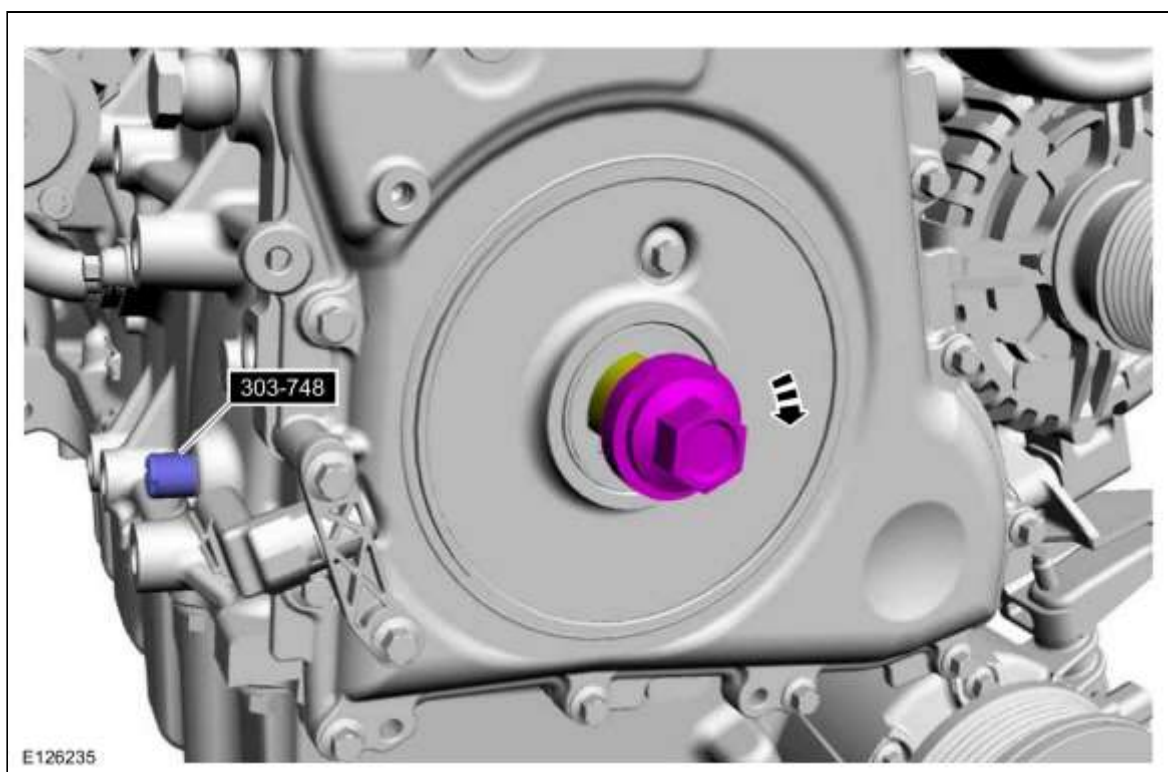

39.

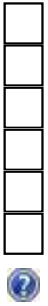
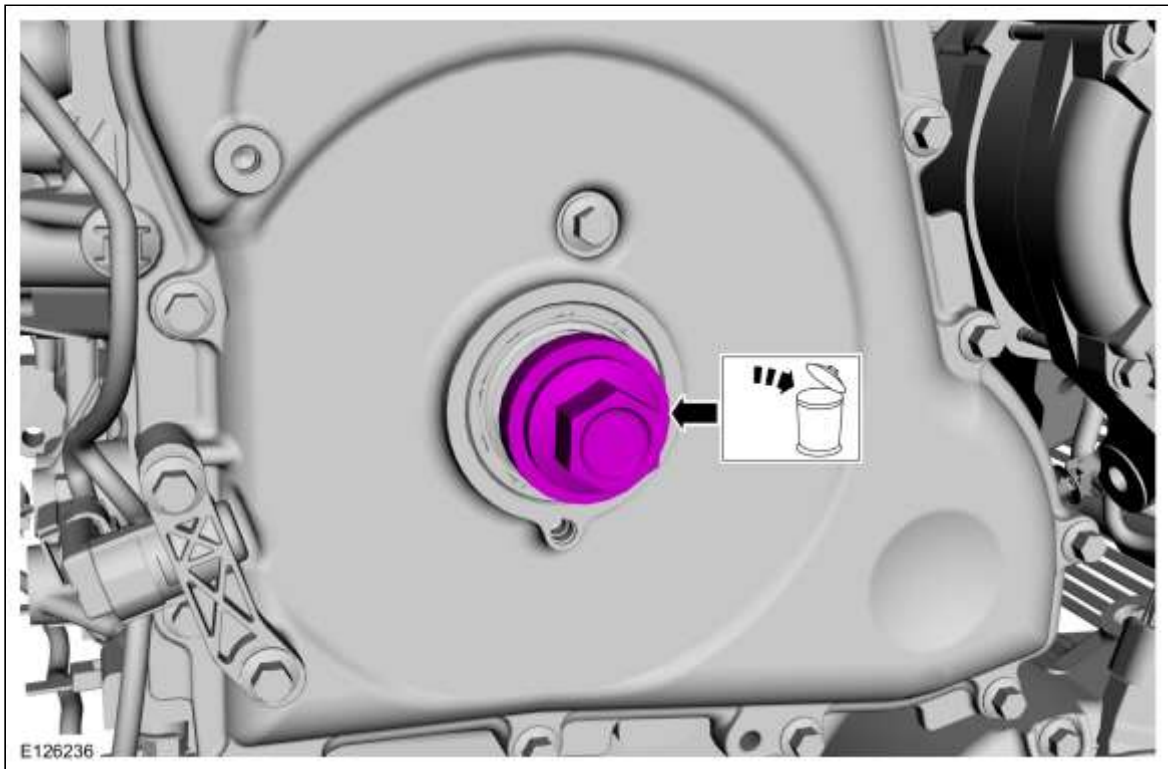

40. 2. **N.B.:** Haal de bout in deze fase slechts handvast aan.

4. Koppel:
 Fase 1: 100 Nm
 Fase 2: 180°

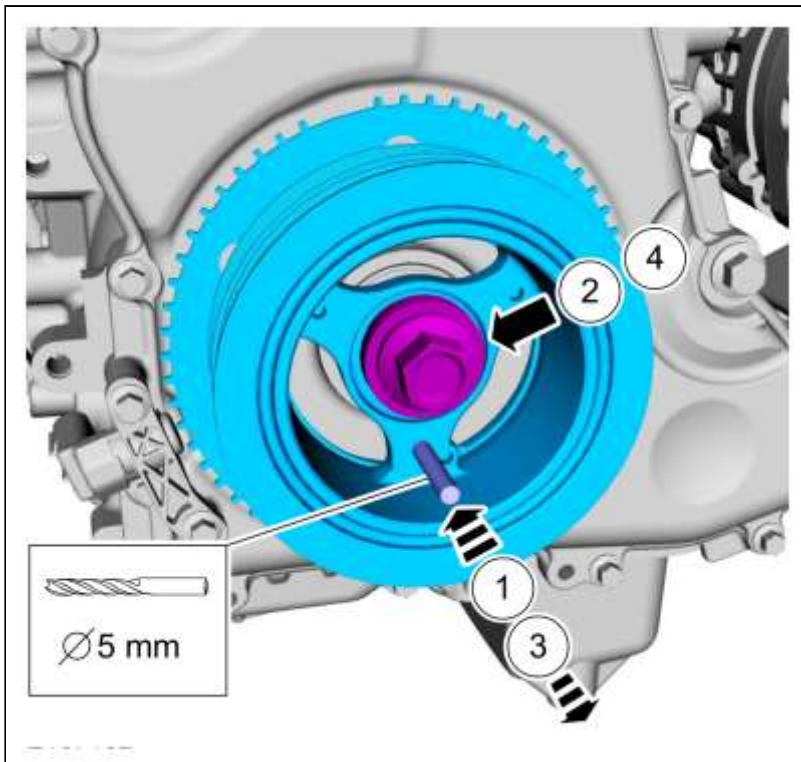

41. **N.B.:** Haal de bout in deze fase slechts handvast aan.

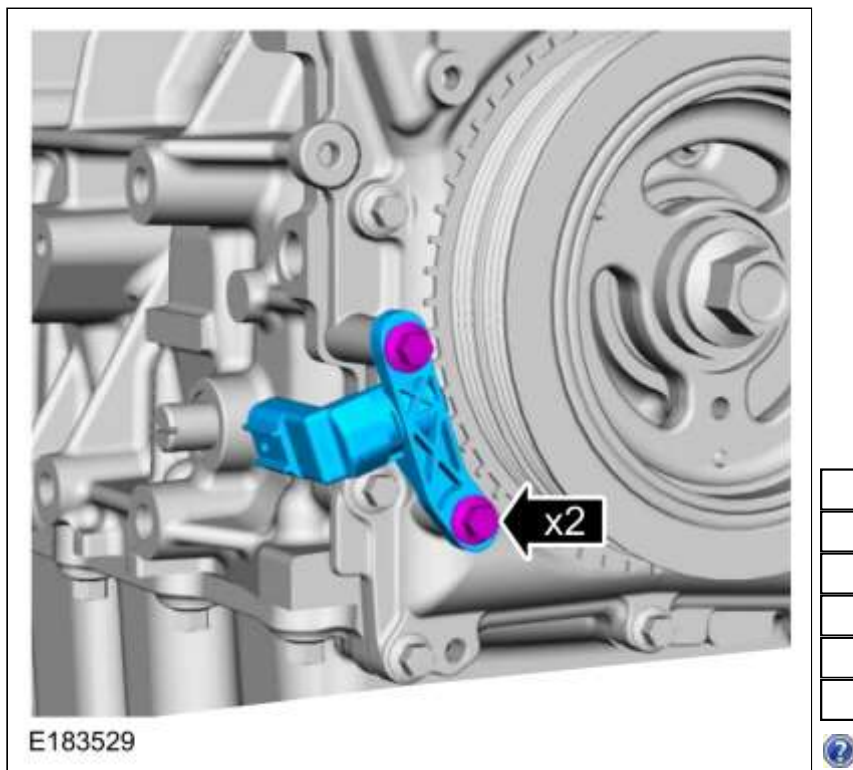

42. Speciaal servicegereedschap gebruiken: 303-1521 Richtgereedschap, krukaspositiesensor.
Koppel: 7 Nm

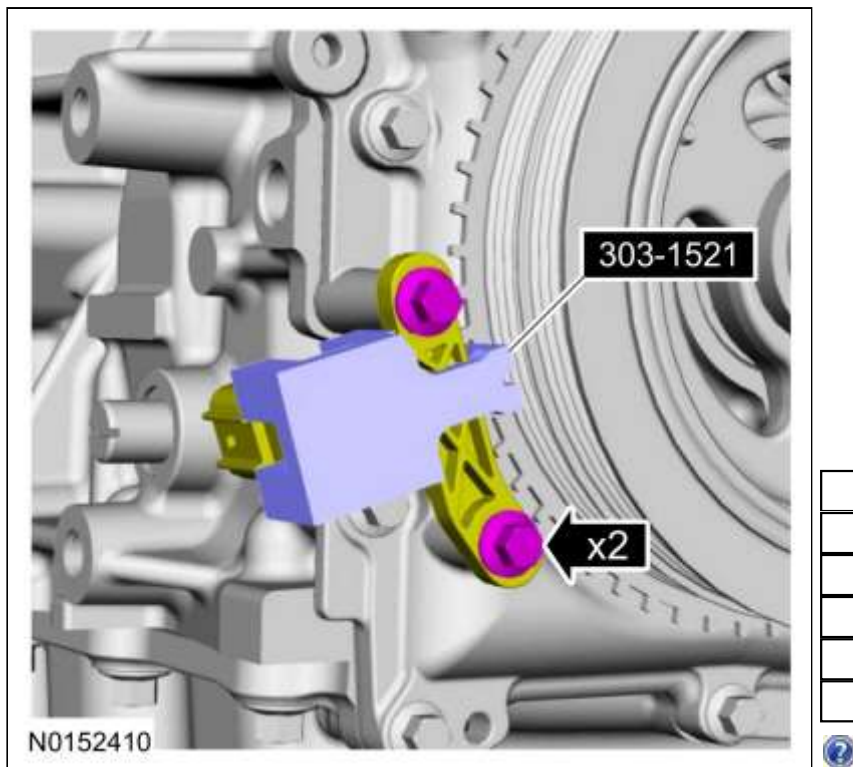

43. Speciaal gereedschap verwijderen: 303-1521 Richtgereedschap, krukaspositiesensor.

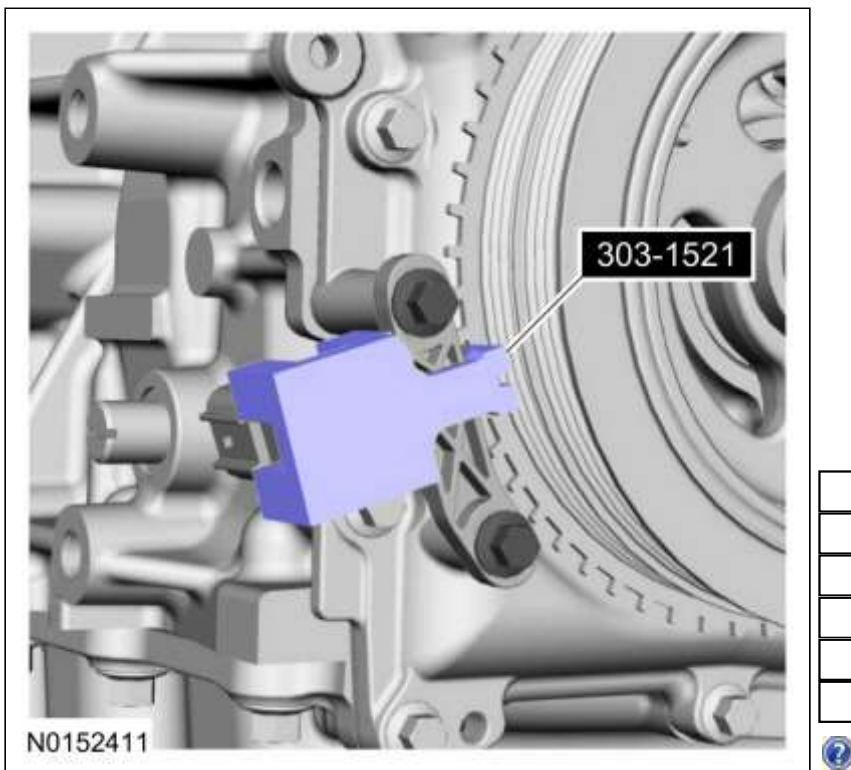

44. Speciaal gereedschap verwijderen: 303-748 Borggereedschap, krukas.

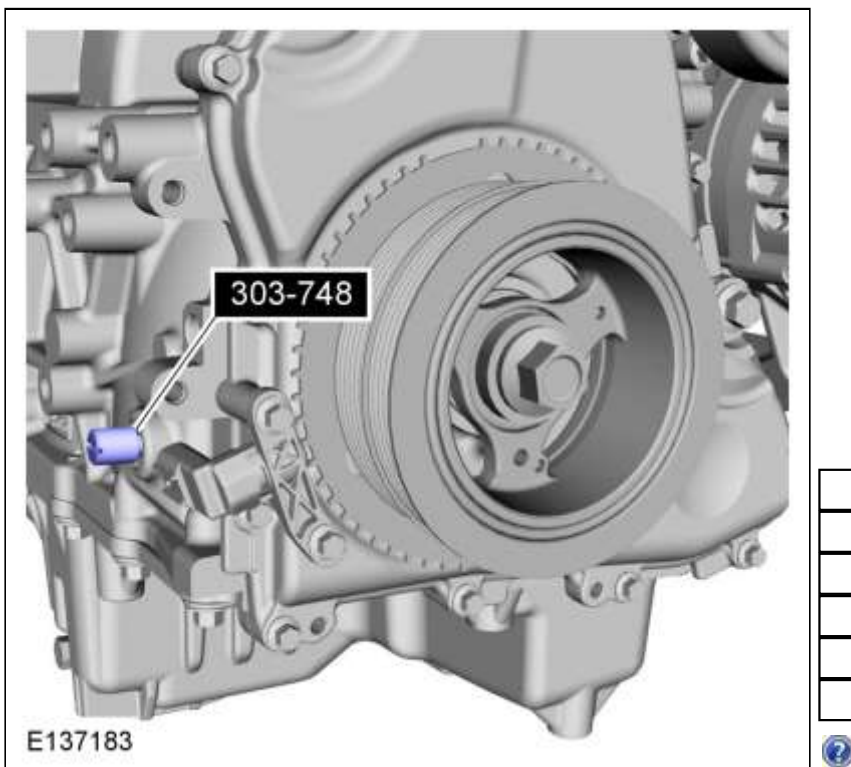

45. Koppel: 20 Nm

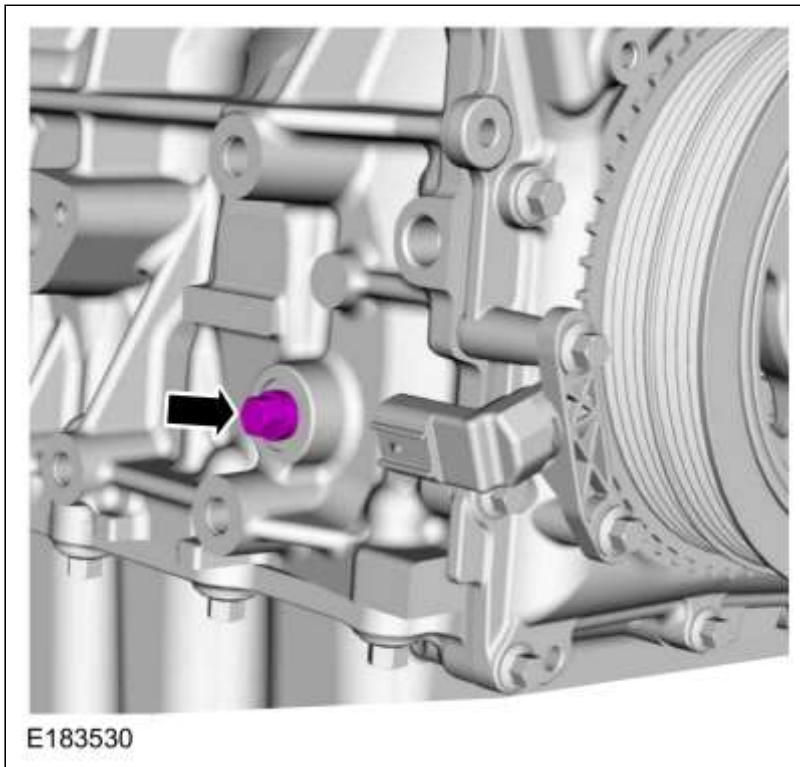

46. Speciaal gereedschap verwijderen: 303-1565 Richtgereedschap, nokkenas.

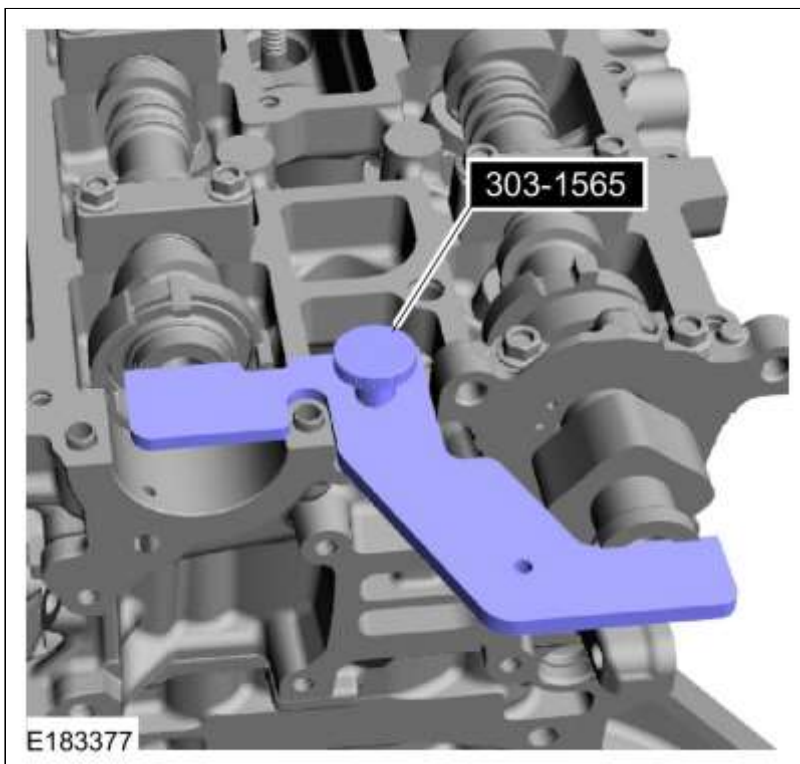

47. Koppel: 63 Nm

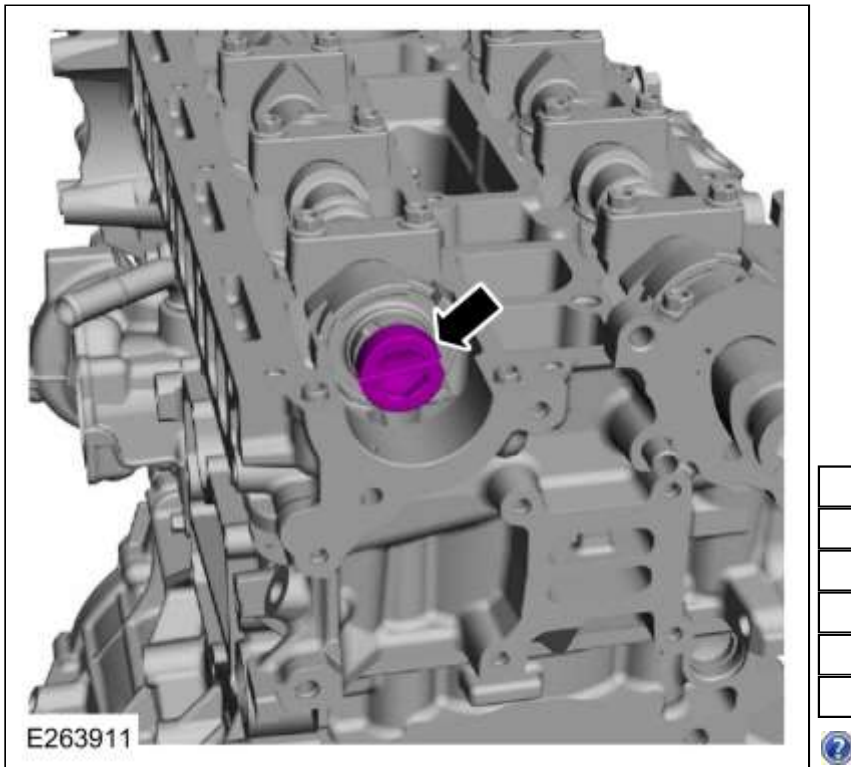

48.

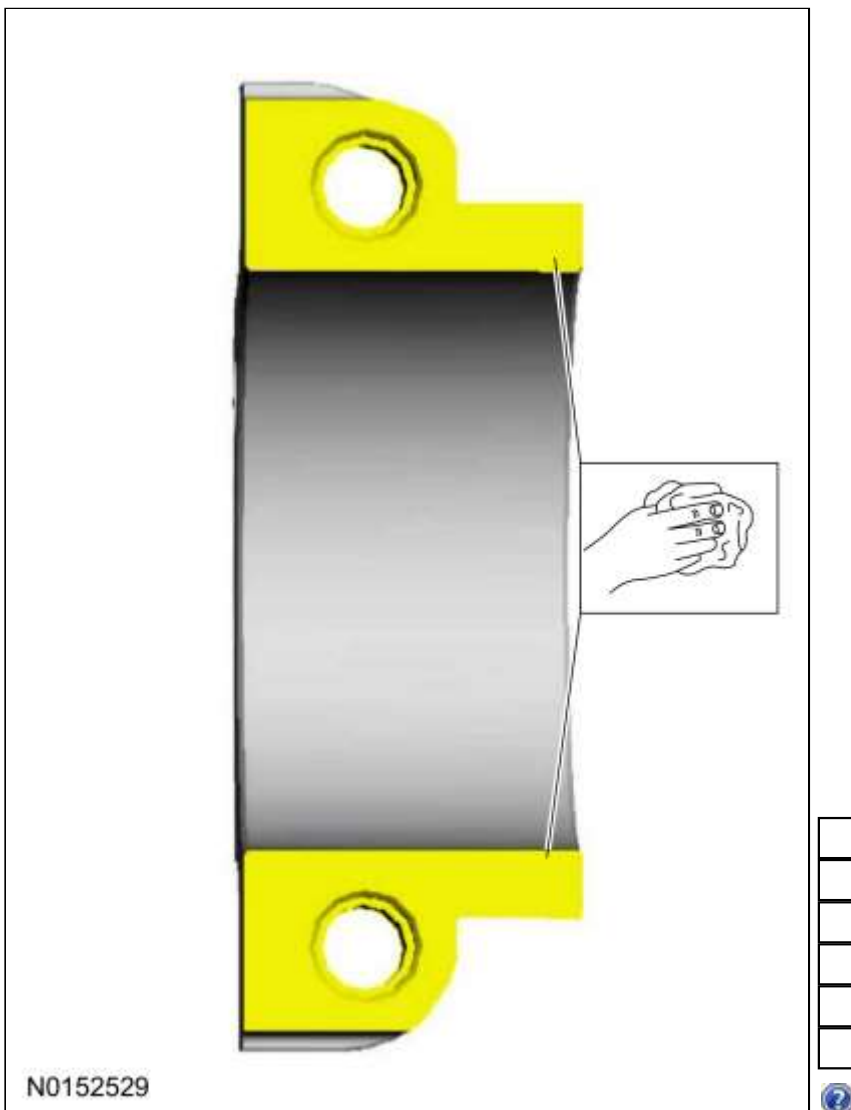

49. **N.B.:** Het onderdeel moet binnen 10 minuten na het aanbrengen van het afdichtmiddel worden aangebracht.

Materialen: Oppervlakte-afdichtmiddel - anaeroob LR-2 / 2U7J-M2G348-BA (WSK-M2G348-A5)
Materialen: Primer H-BW / CU7J-BNDRT-AA/CA

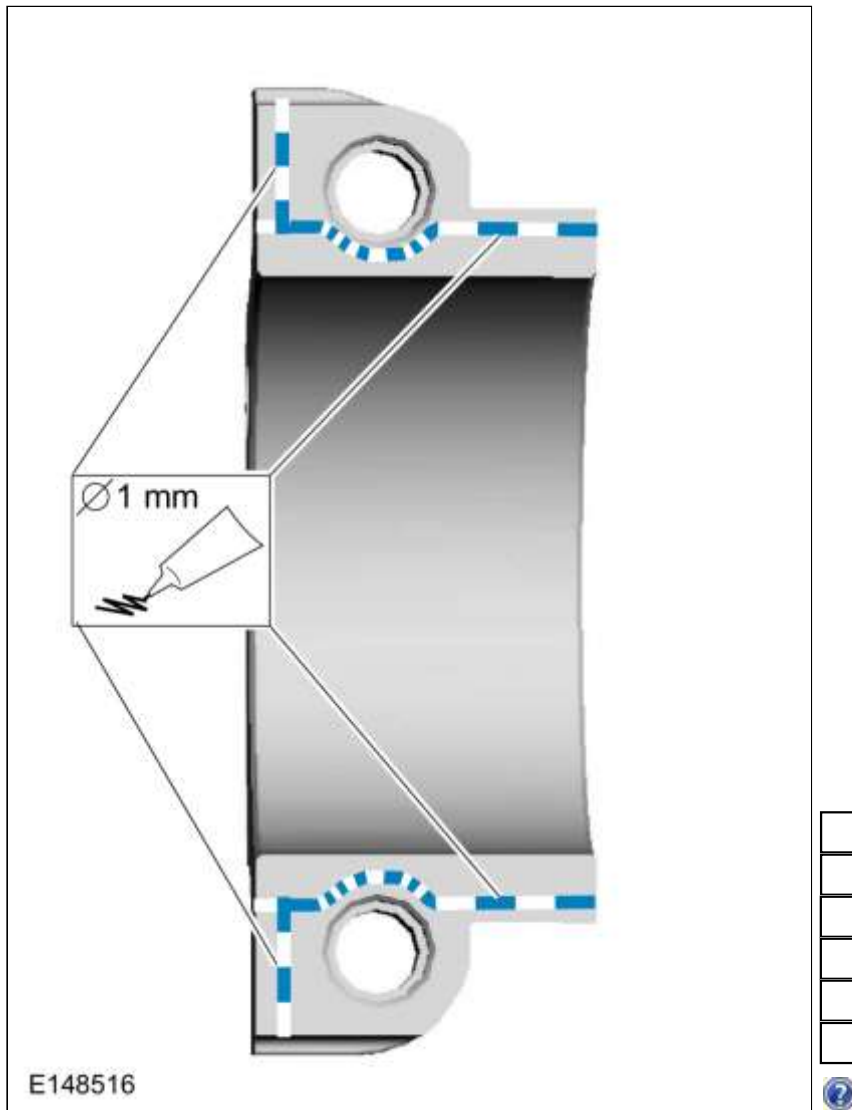

50. Koppel:
Fase 1: 7 Nm
Fase 2: 16 Nm

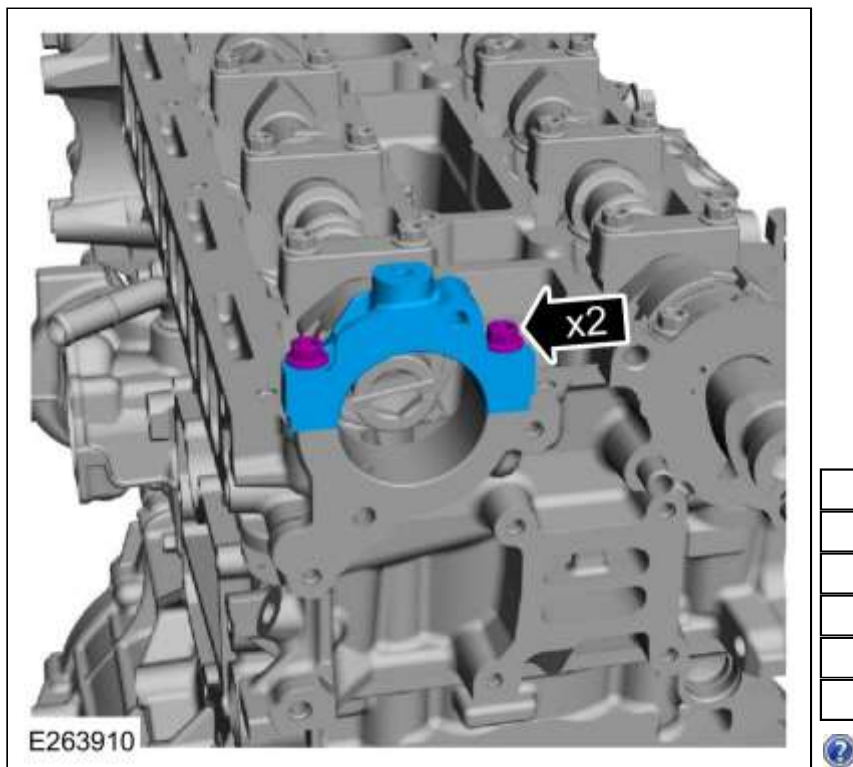

51. **KENNISGEVING:** Zorg dat het gereedschap en de apparatuur schoon zijn. Er mag geen vuil of smeermiddel op zitten.

KENNISGEVING: Zorg dat het onderdeel schoon is en vrij van verontreinigingen en smeermiddel.

KENNISGEVING: Wees extra voorzichtig bij het hanteren van het onderdeel.

N.B.: Gebruik alleen matige kracht.

1. Speciaal servicegereedschap gebruiken: 310-128 Gereedschapsset om teflon afdichting aan te brengen.
2. **N.B.:** Zorg dat een nieuw onderdeel wordt aangebracht.
3. Speciaal servicegereedschap gebruiken: 310-128 Gereedschapsset om teflon afdichting aan te brengen.
4. Speciaal servicegereedschap gebruiken: 310-128 Gereedschapsset om teflon afdichting aan te brengen.

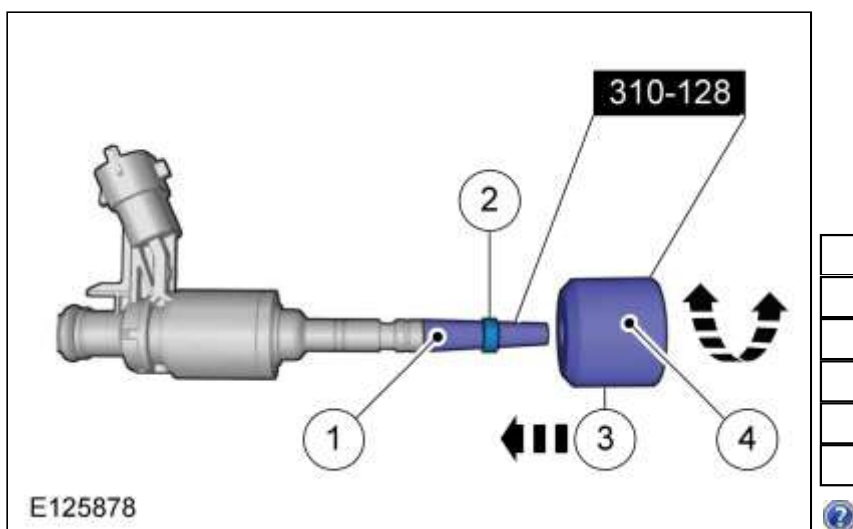

52. **KENNISGEVING:** Wees extra voorzichtig bij het hanteren van het onderdeel.

N.B.: Zorg dat een nieuw onderdeel wordt aangebracht.

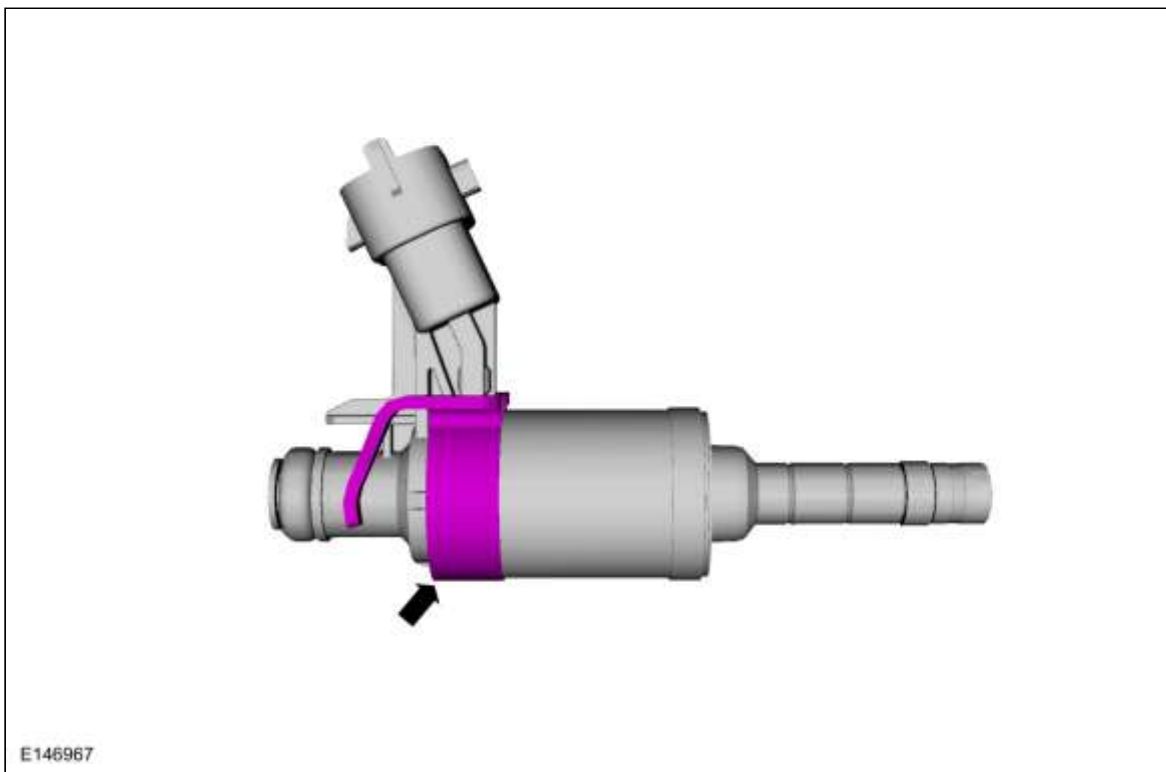

53. *Materialen:* Wij raden aan: Ford-Castrol Magnatec (WSS-M2C948-B)

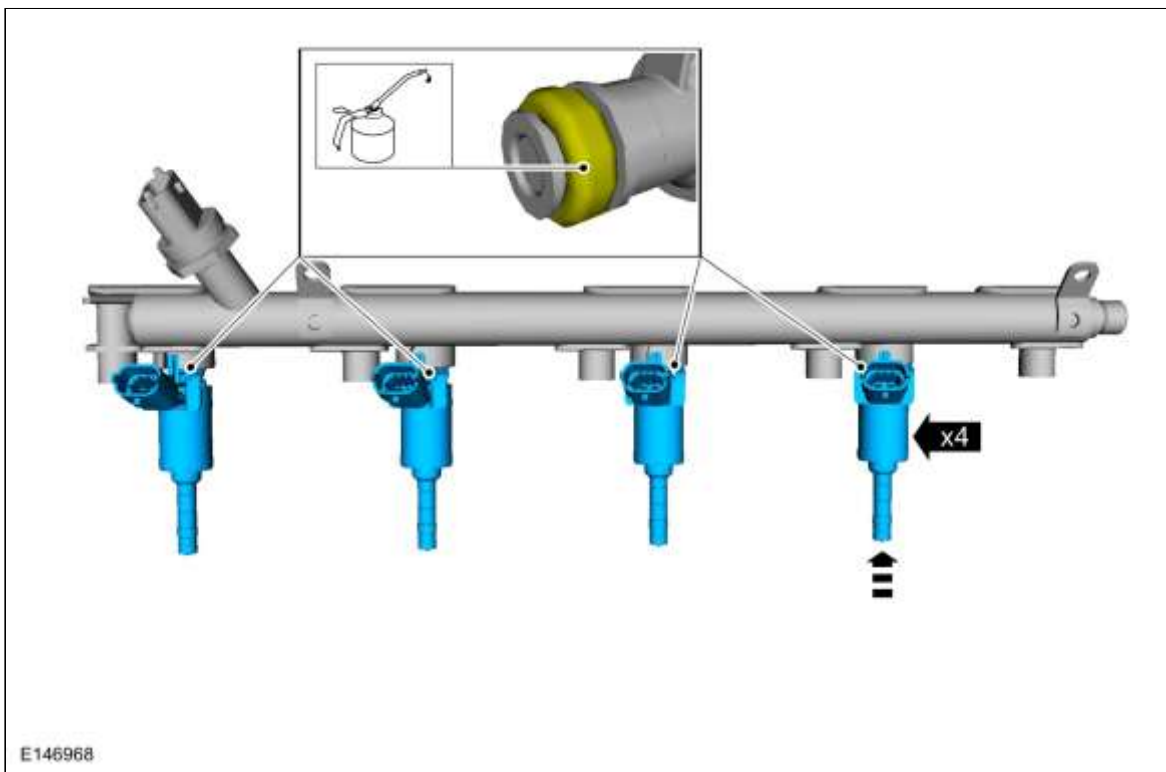

54. **KENNISGEVING:** Zorg dat het onderdeel schoon is en vrij van verontreinigingen en smeermiddel.

KENNISGEVING: De onderdelen moeten uiterst voorzichtig worden gehanteerd.

N.B.: Gebruik alleen matige kracht.

N.B.: Haal alle bouten handvast aan alvorens ze op aanhaalmoment aan te halen.

Haal iedere bout 1 omwenteling per keer aan.

Koppel:

Fase 1: 8 Nm

Fase 2: 26°

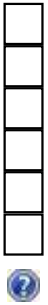
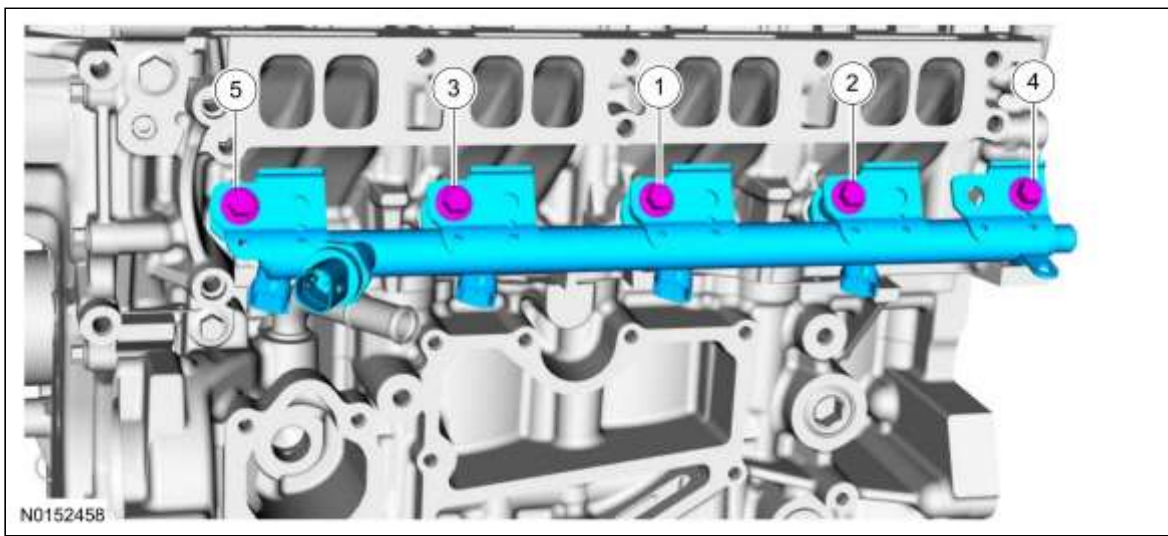

55.

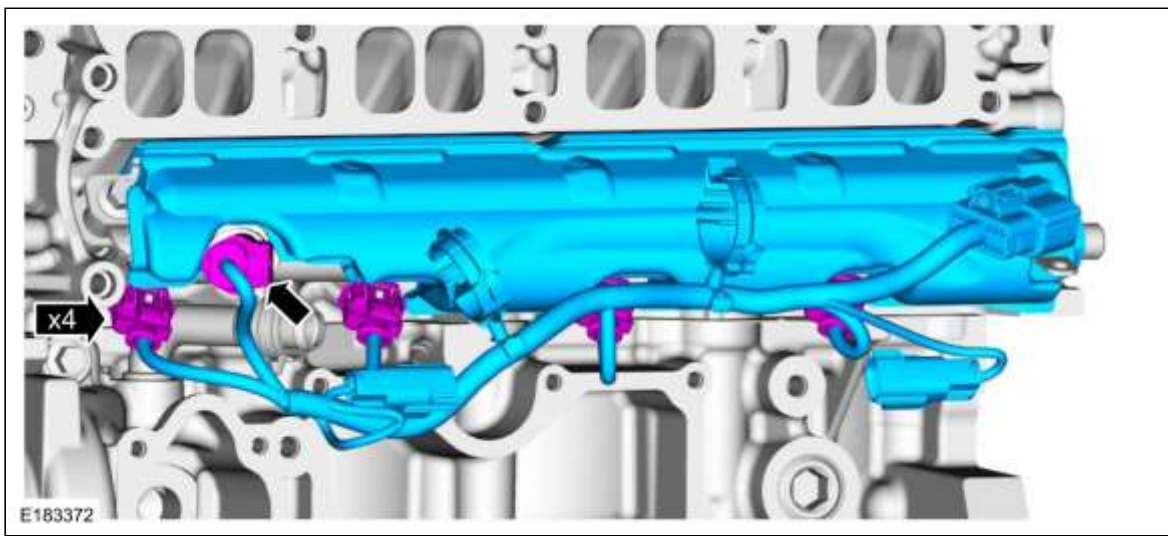

56.

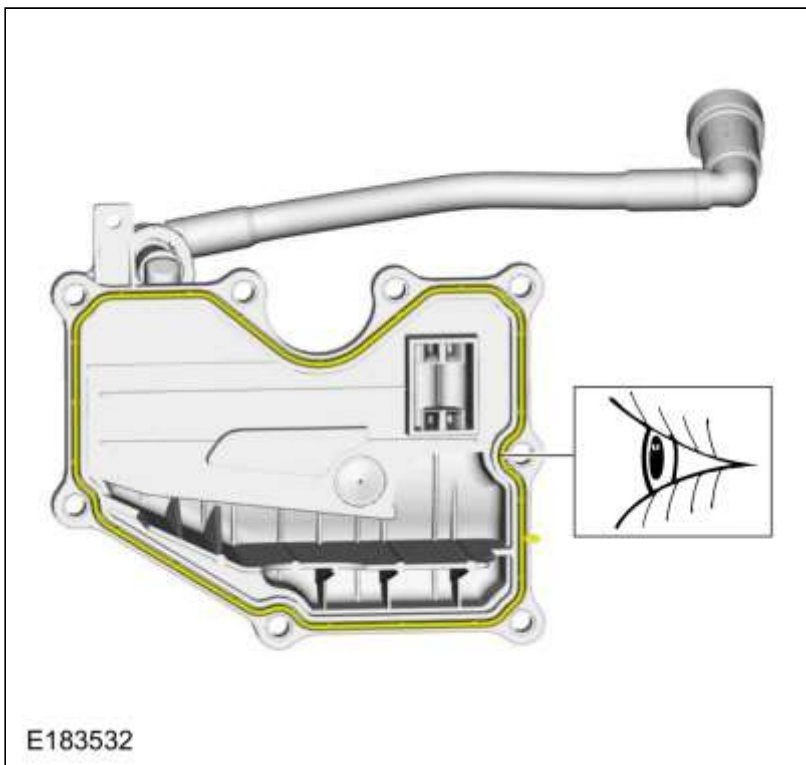

57. Koppel: 10 Nm

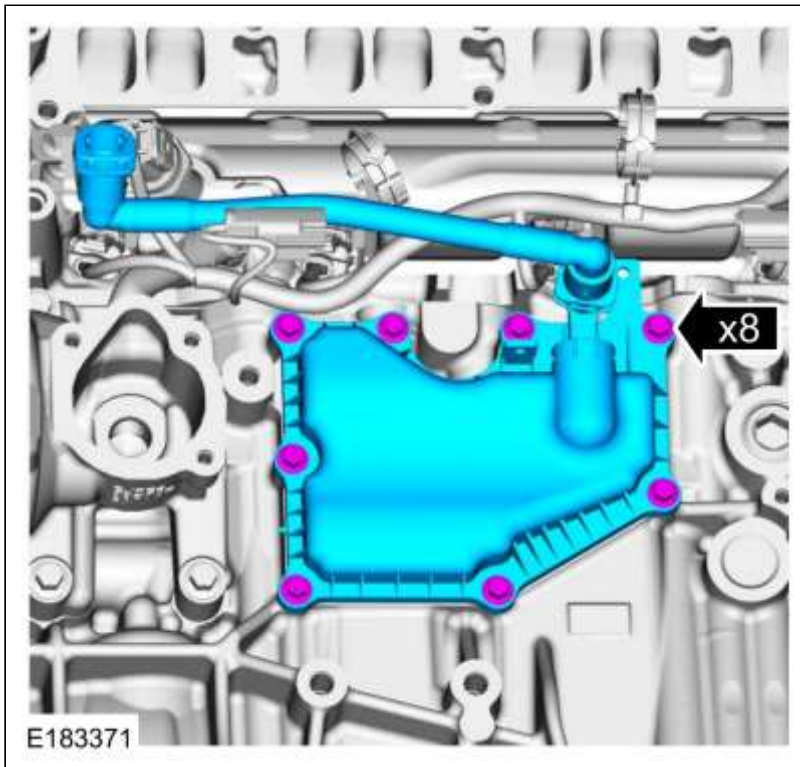

58. Koppel: 20 Nm

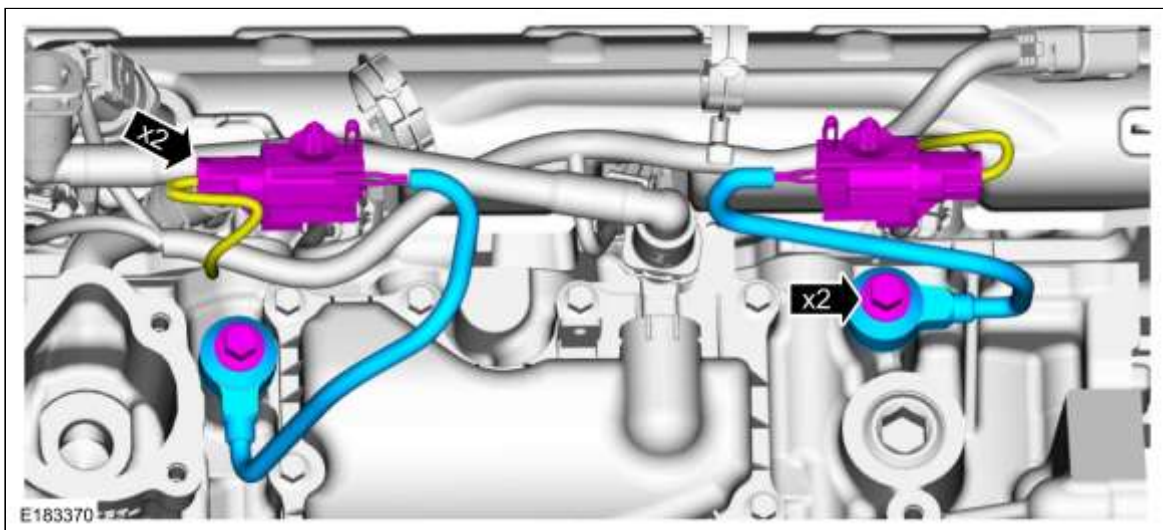

59.

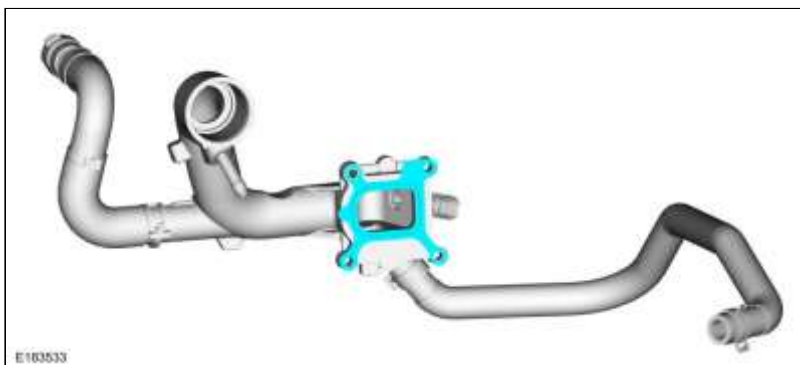

60. Koppel: 10 Nm

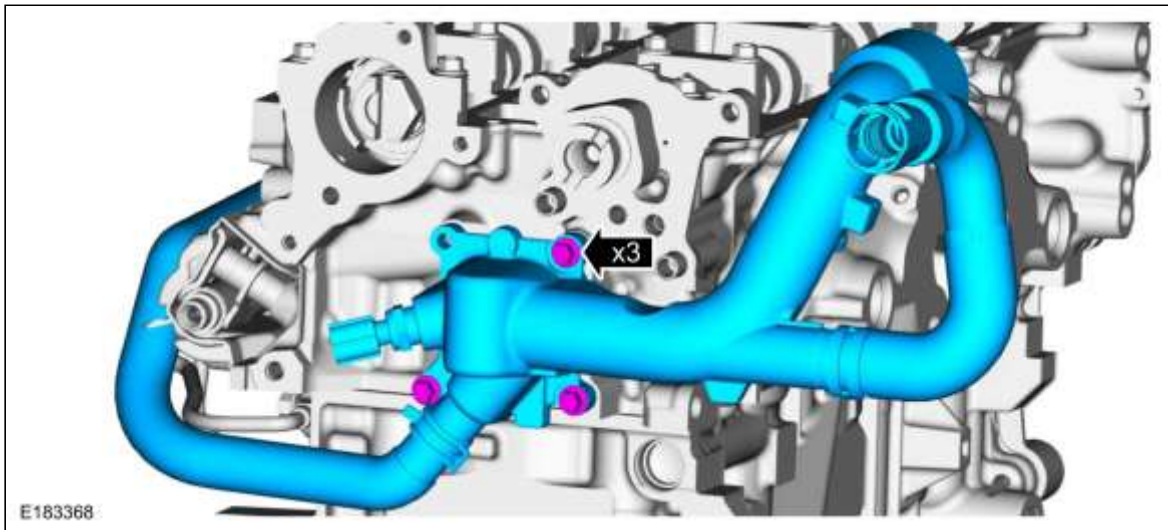

61. Algemene Uitrusting: Demontage-/montagegereedschap slangklemmen

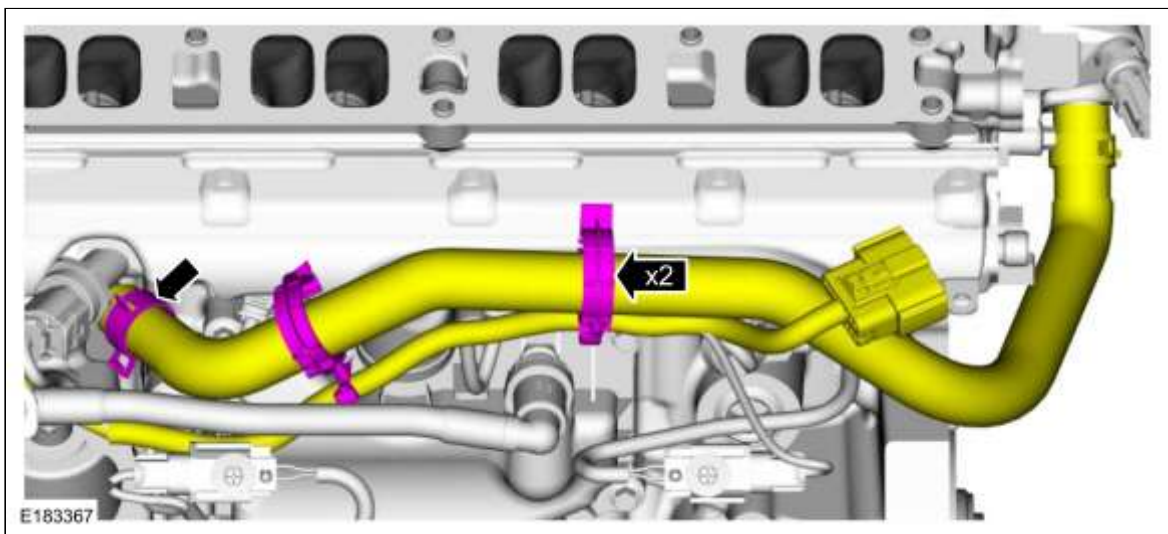

62. **N.B.:** Zorg dat er nieuwe onderdelen worden aangebracht.

Speciaal servicegereedschap gebruiken: 204-017 Gereedschap om buitenste lagerring wielnaaf aan te brengen.

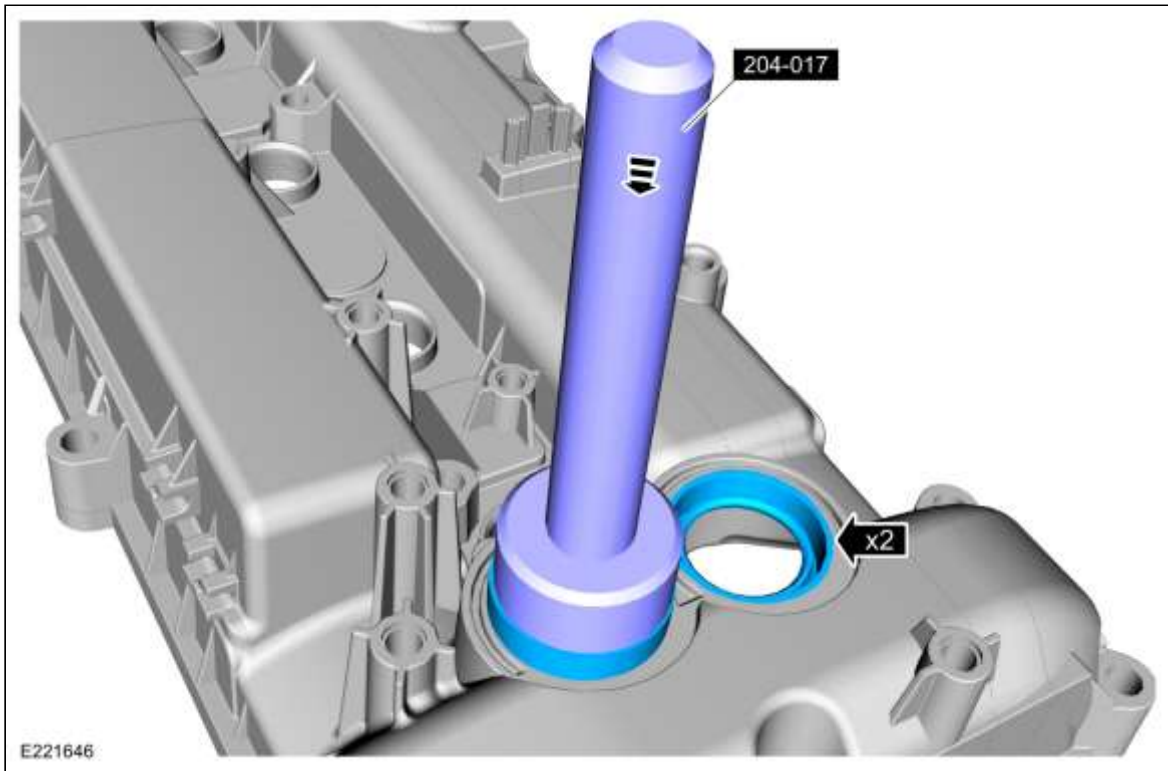

63.

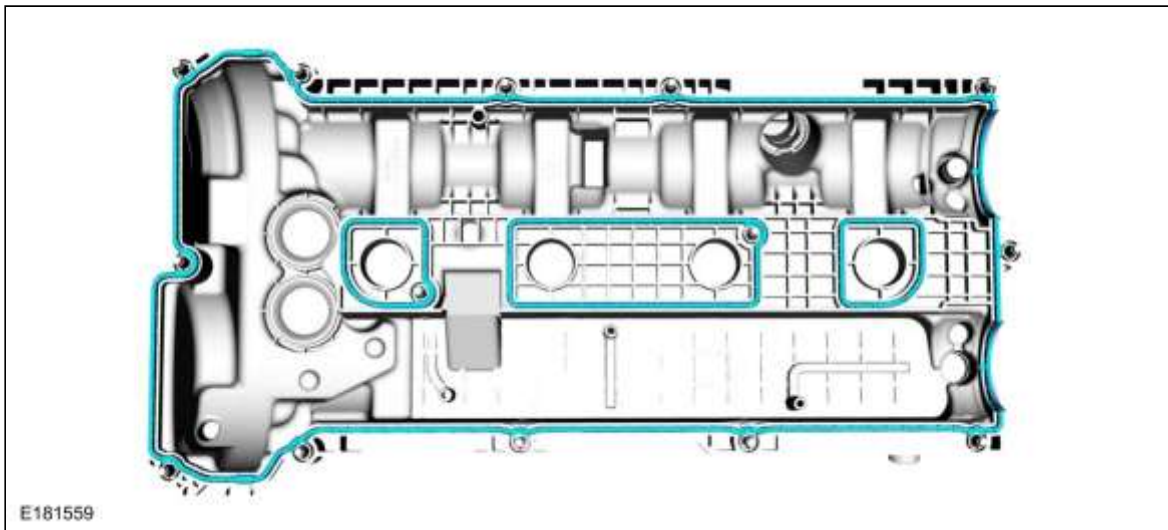

64. *Materialen:* Siliconenkit LB / NU7J-M4G323-AB (WSE-M4G323-A4)

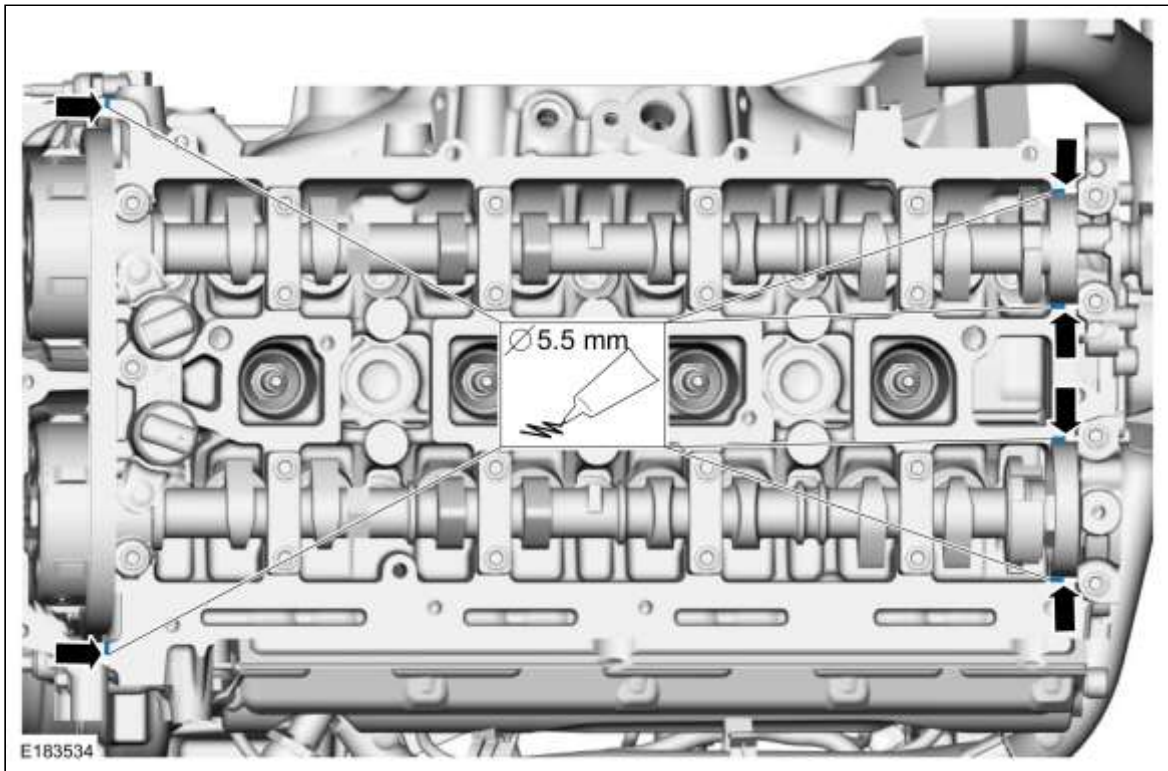

65. **N.B.:** Het onderdeel moet binnen 5 minuten na het aanbrengen van het afdichtmiddel worden aangebracht.

Koppel: 10 Nm

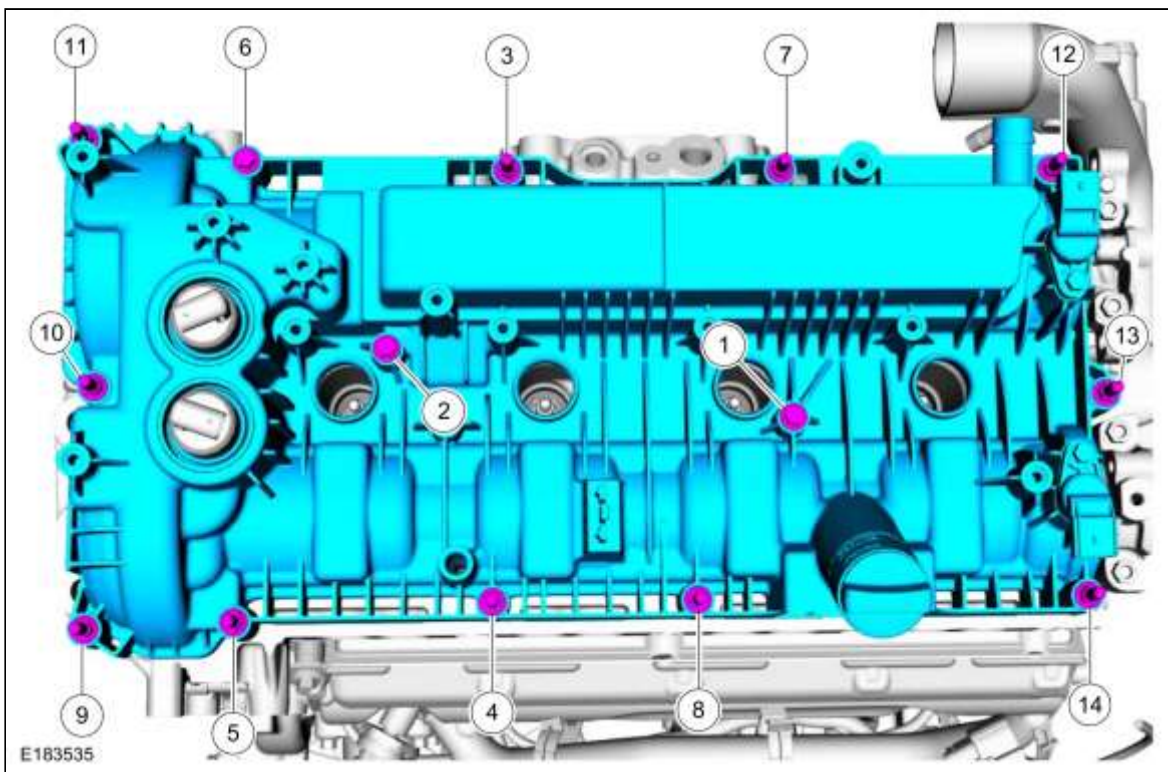

66. Koppel: 6 Nm

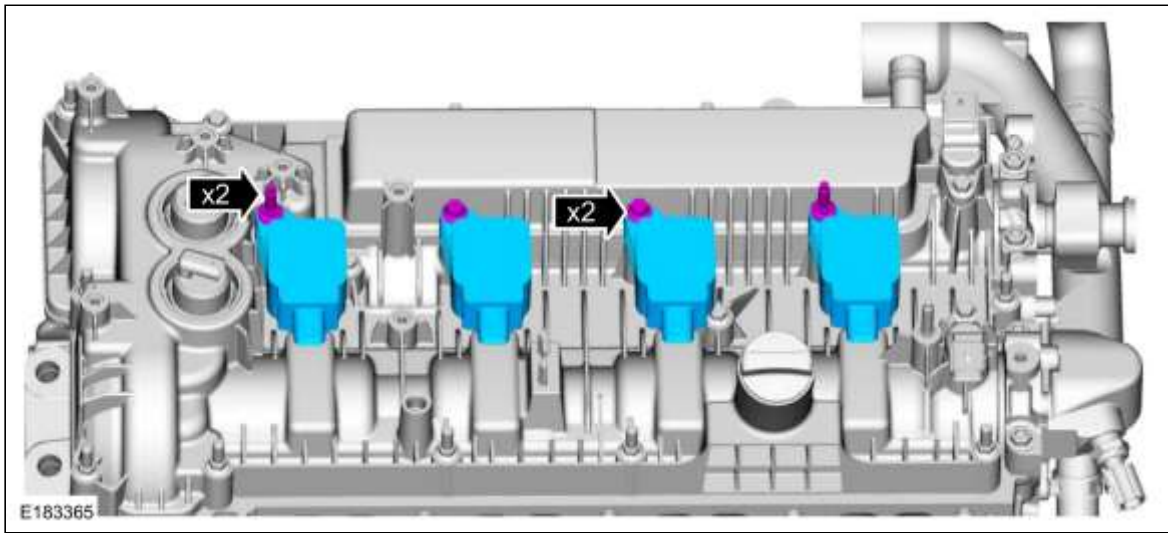

67. **KENNISGEVING:** Breng een nieuw onderdeel aan.

Koppel: 11 Nm

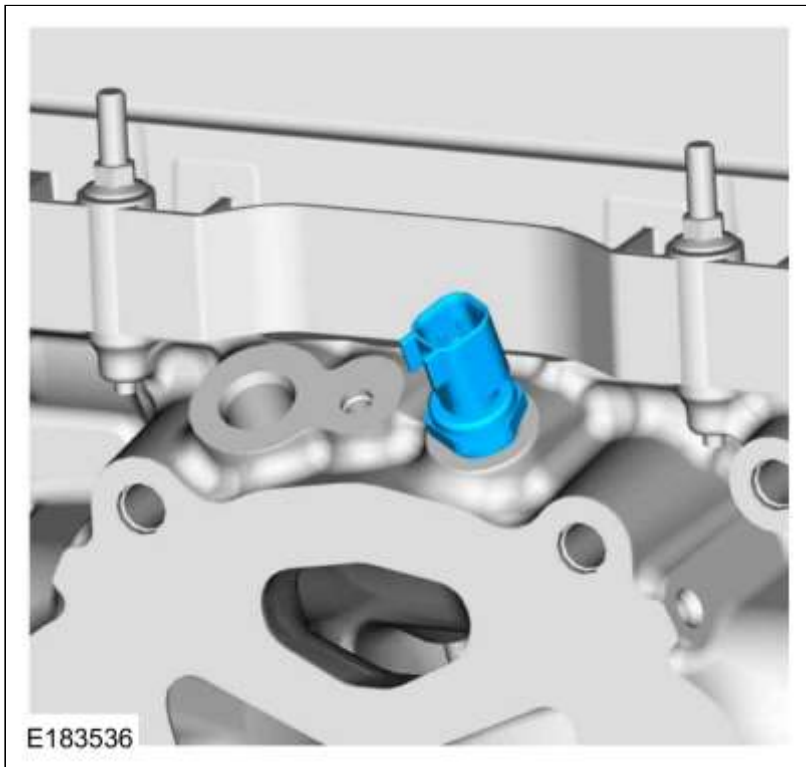

68.

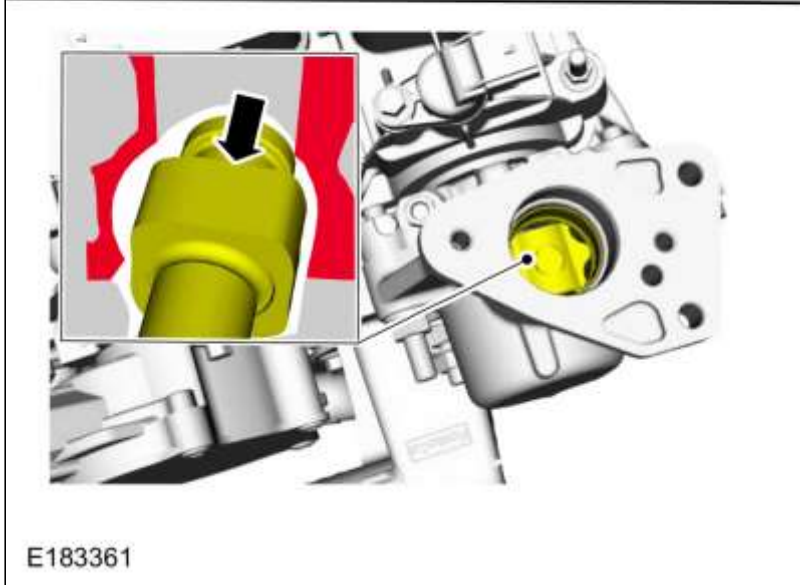
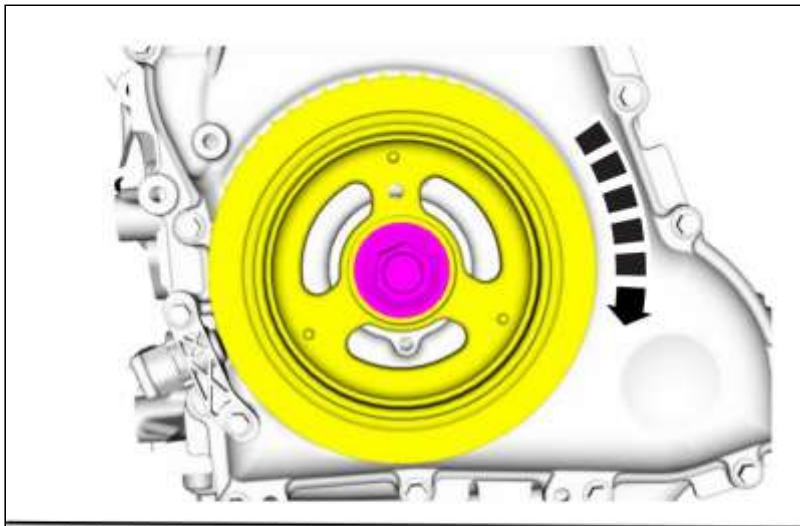

E183361



69.

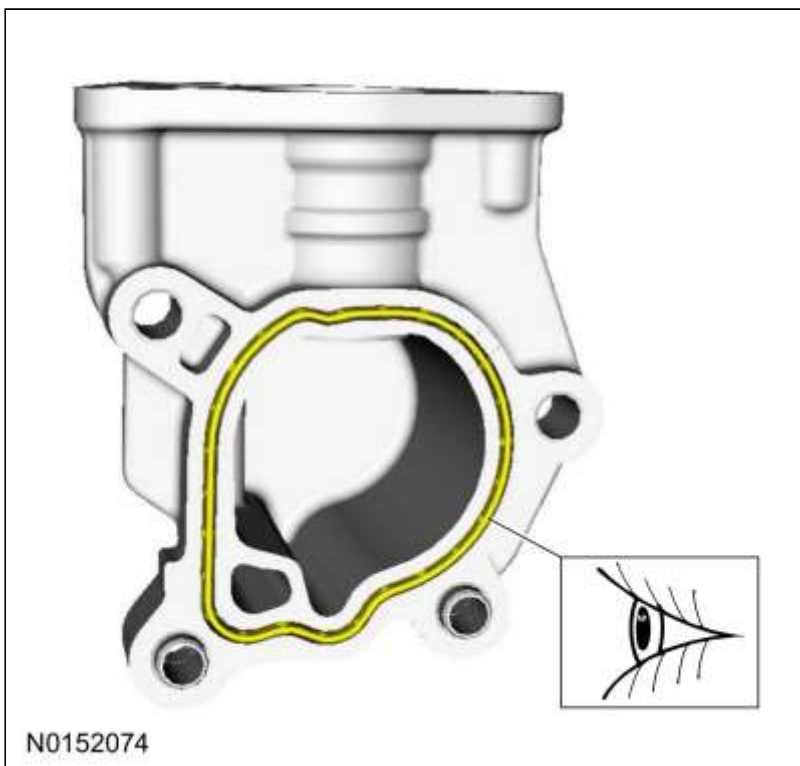

N0152074



70. Koppel:
Fase 1: 15 Nm

Fase 2: 60°

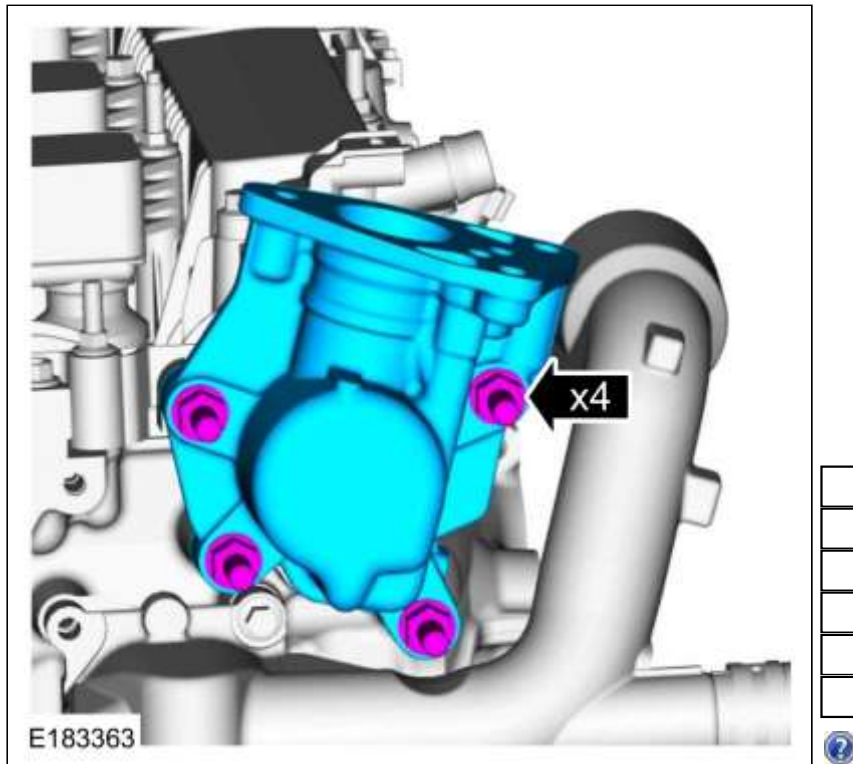

71. *Materialen:* Wij raden aan: Ford-Castrol Magnatec (WSS-M2C913-D)

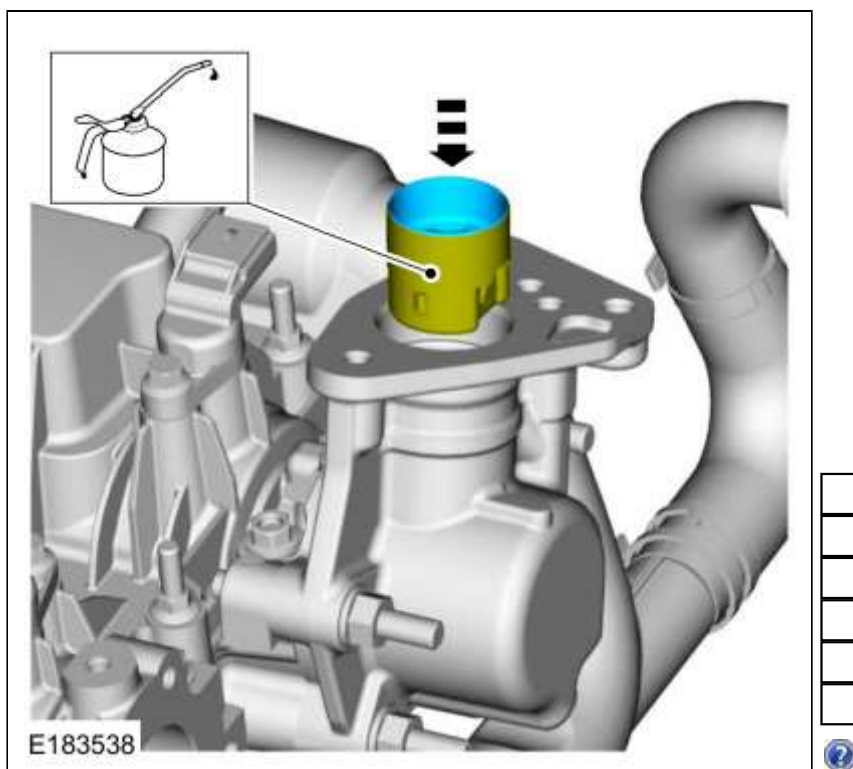

72. *Materialen:* Wij raden aan: Ford-Castrol Magnatec (WSS-M2C913-D)

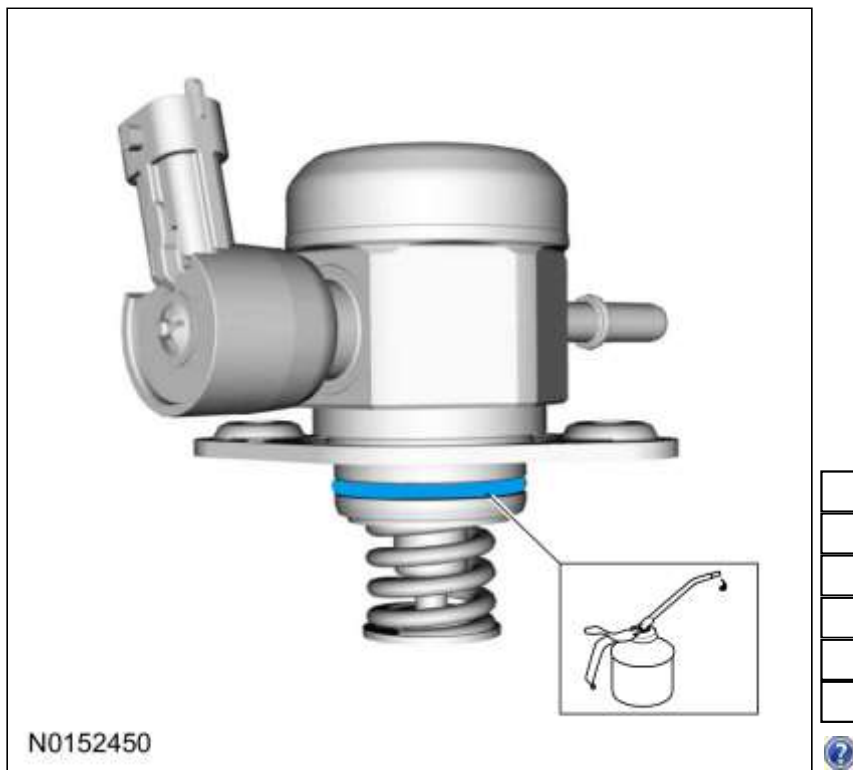

73. **N.B.:** Zorg dat nieuwe bouten worden gebruikt.

Zet iedere bout een halve omwenteling per keer vast.

Koppel:

Fase 1: 5 Nm

Fase 2: 55°

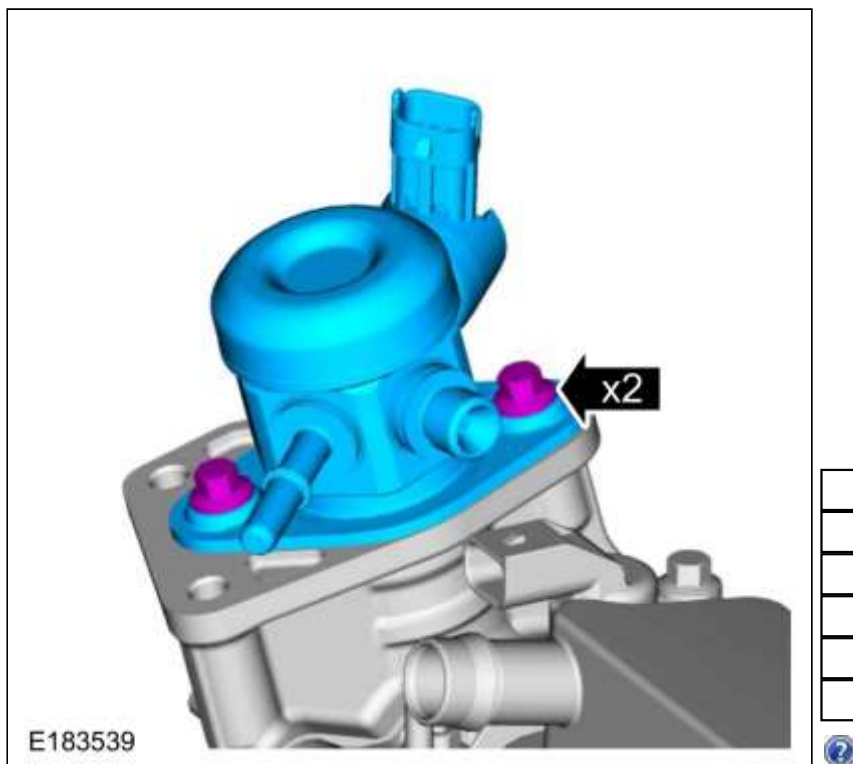

74. *Koppel:* 17 Nm

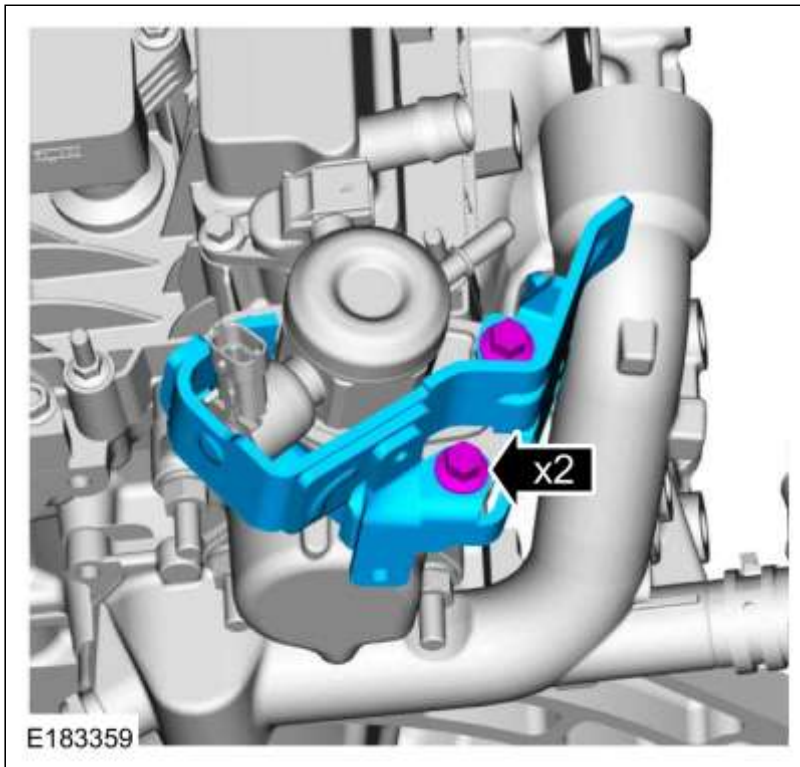

75. **N.B.:** Zorg dat een nieuw onderdeel wordt aangebracht.

-
- Haal de moeren in deze fase handvast aan.

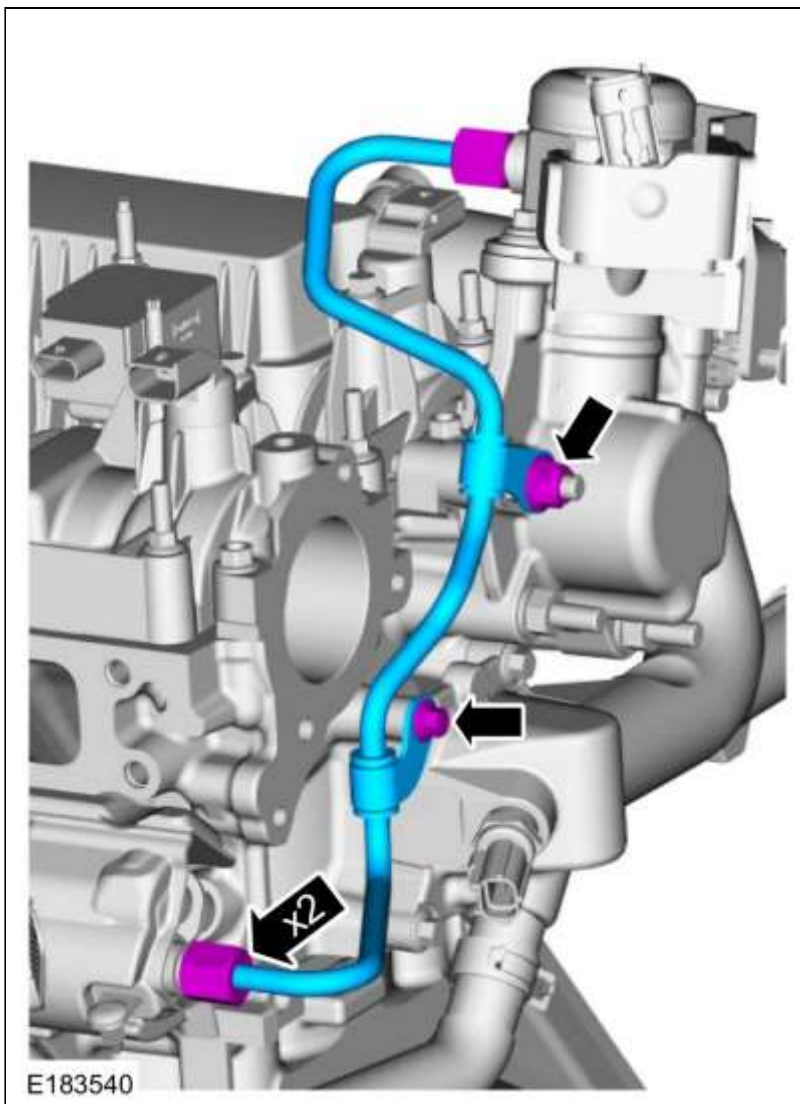

76. *Koppel:*
Fase 1: 15 Nm
Fase 2: 30°

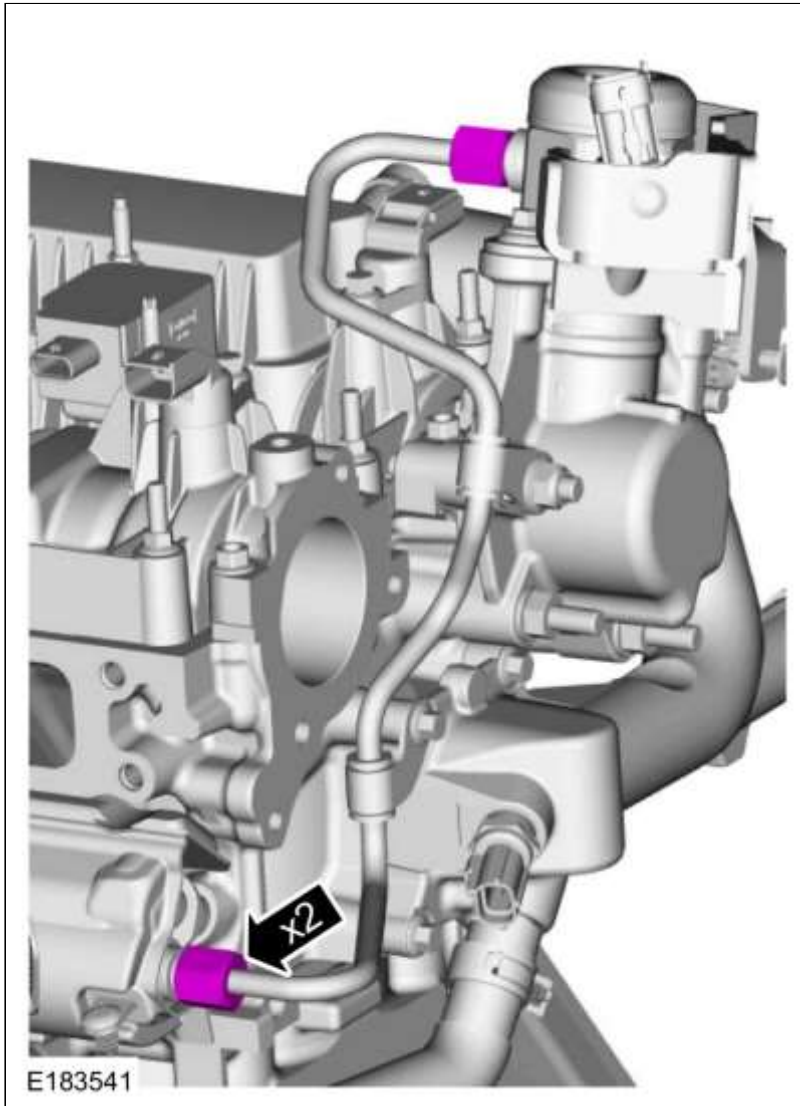

77. 1. *Koppel:* 10 Nm
2. *Koppel:* 17 Nm

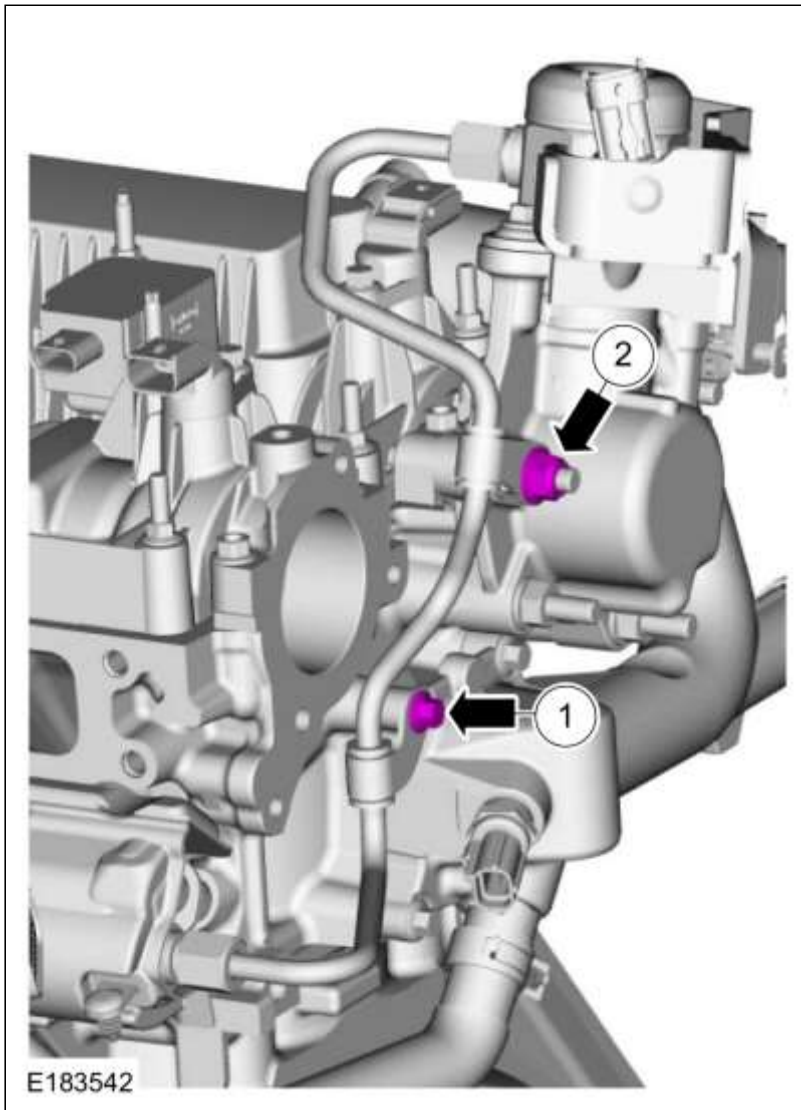

78.

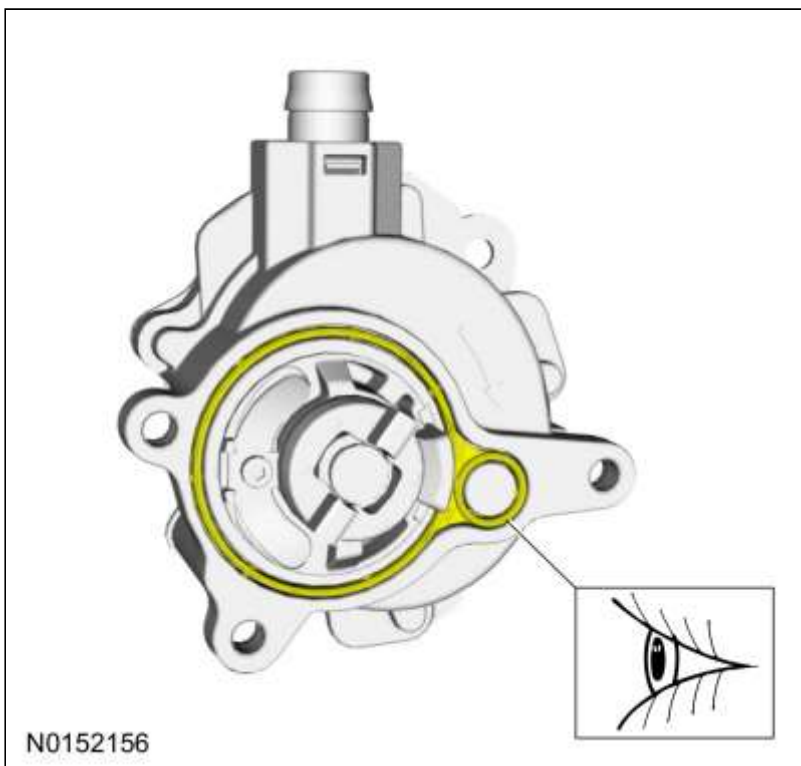

79. Koppel: 10 Nm

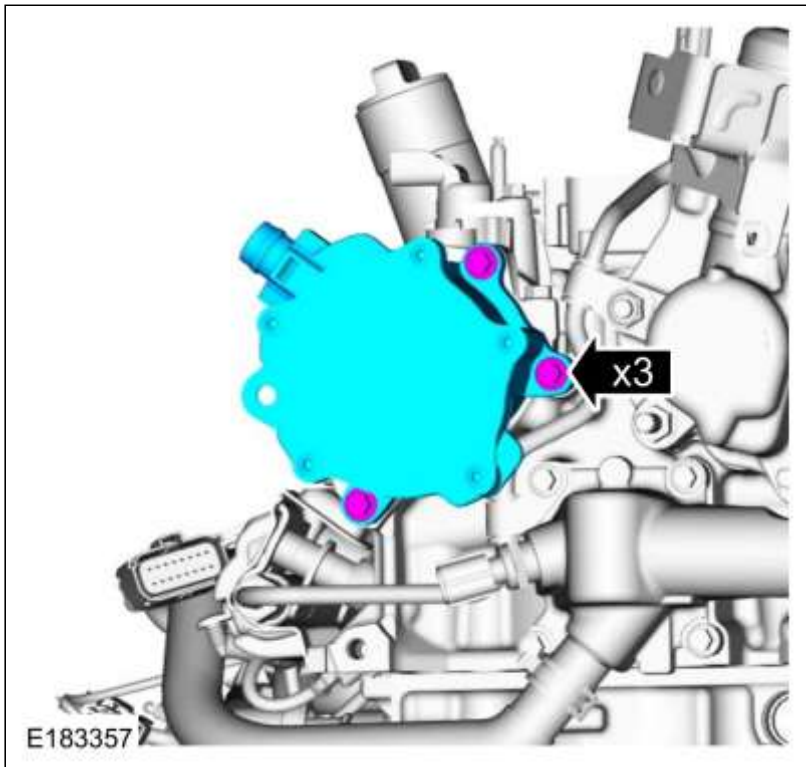

80. *Koppel:* 25 Nm

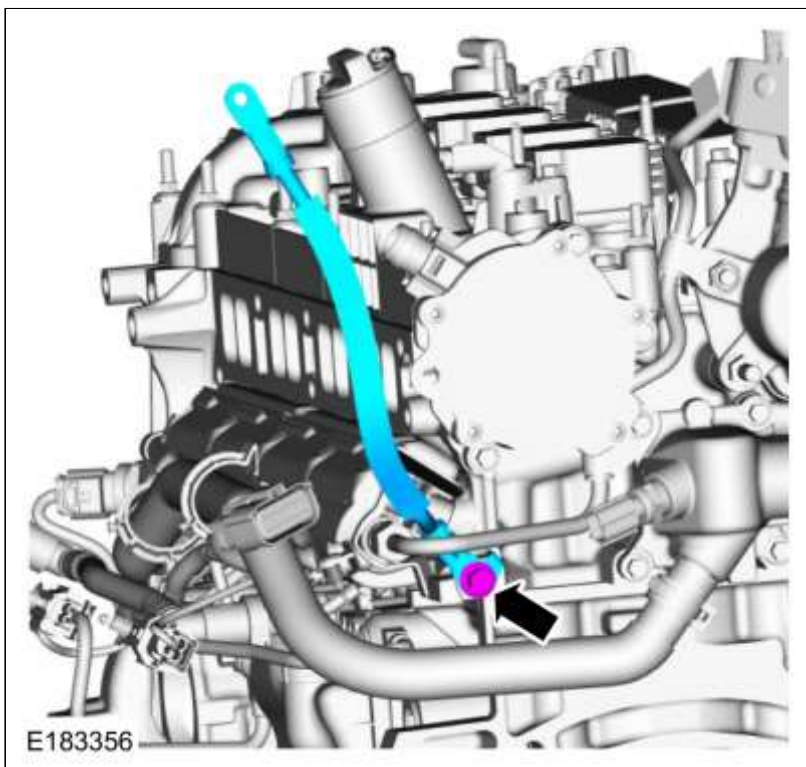

81.

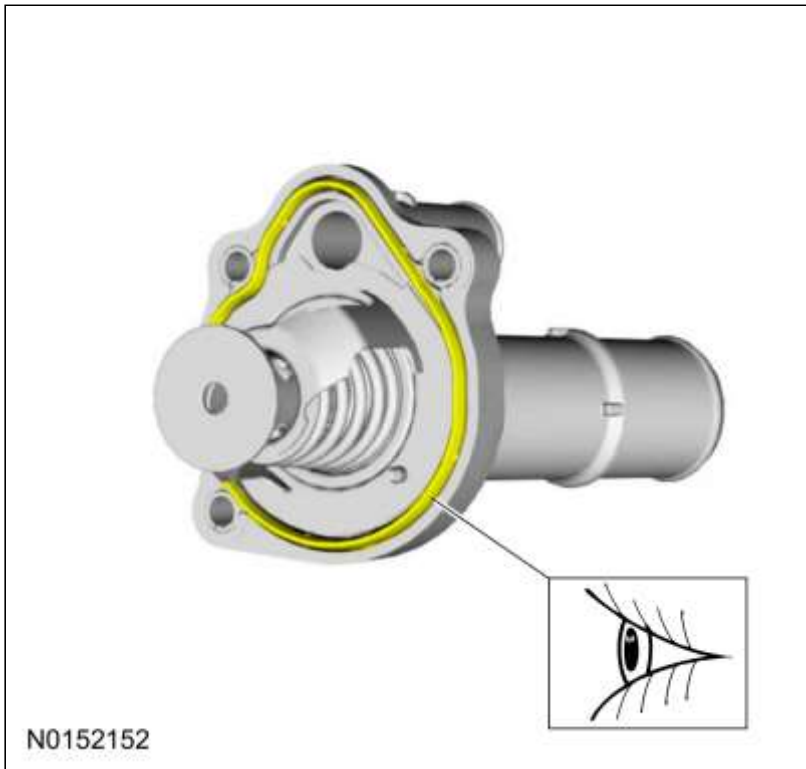

82. 1. Koppel: 10 Nm
2. Koppel: 9 Nm

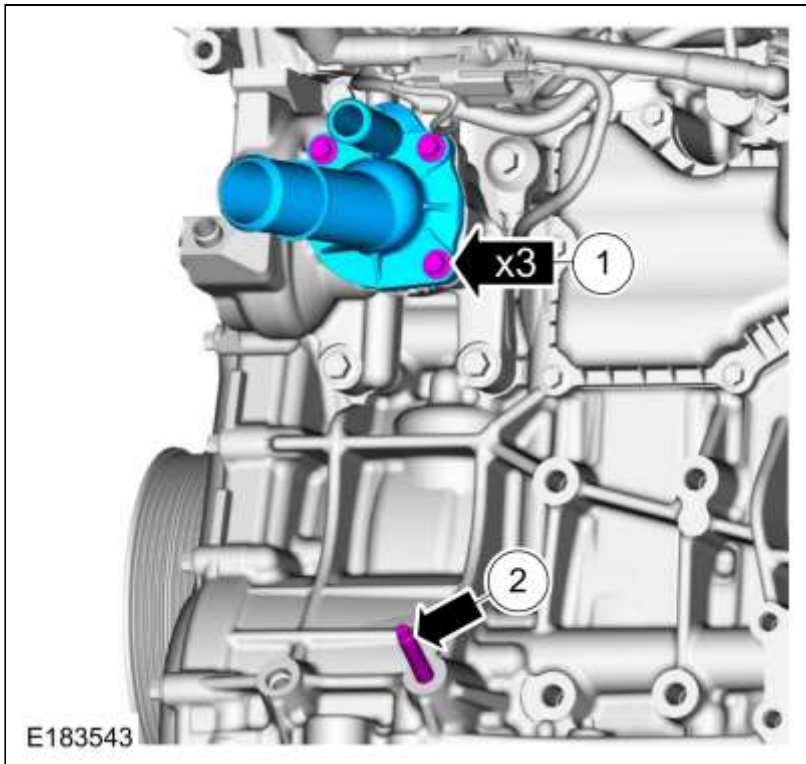

83. *Materialen:* Koelmoeistof Super Plus Premium / FU7J-19544-xx (WSS-M97B44-D)

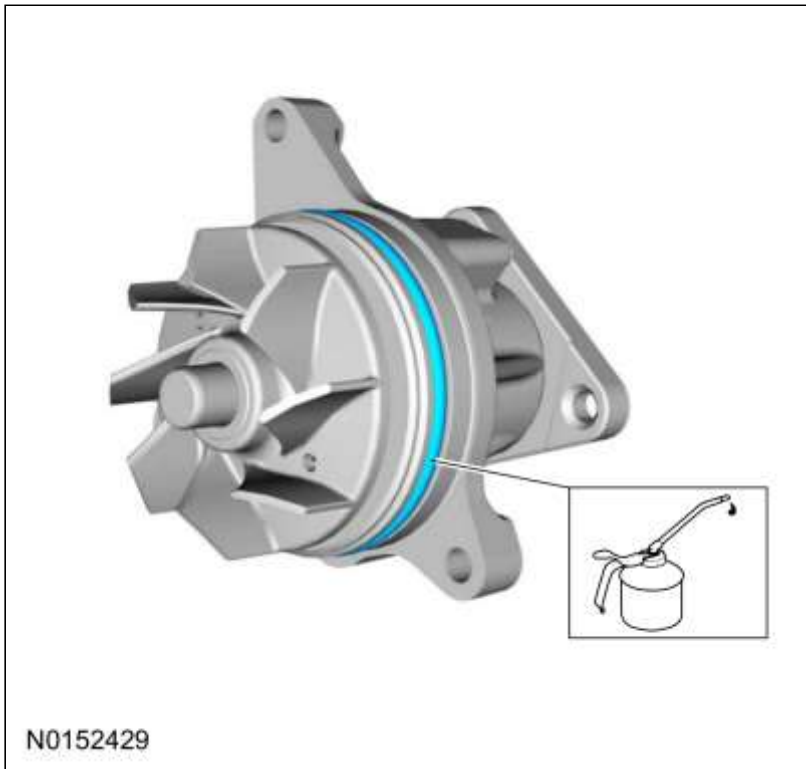

84. *Koppel*: 10 Nm

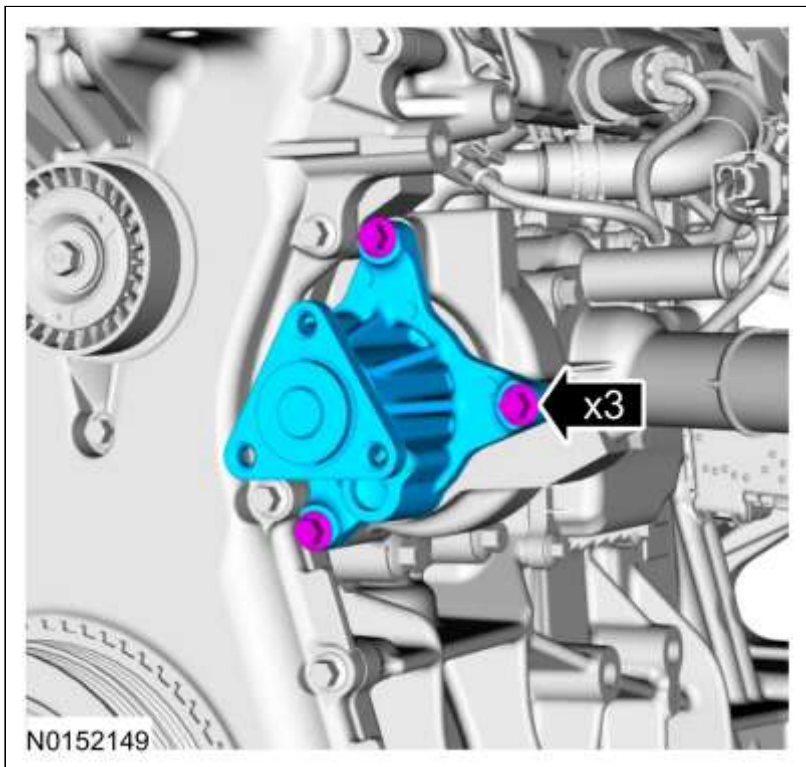

85. 2. *Koppel*: 25 Nm
3. *Koppel*: 25 Nm

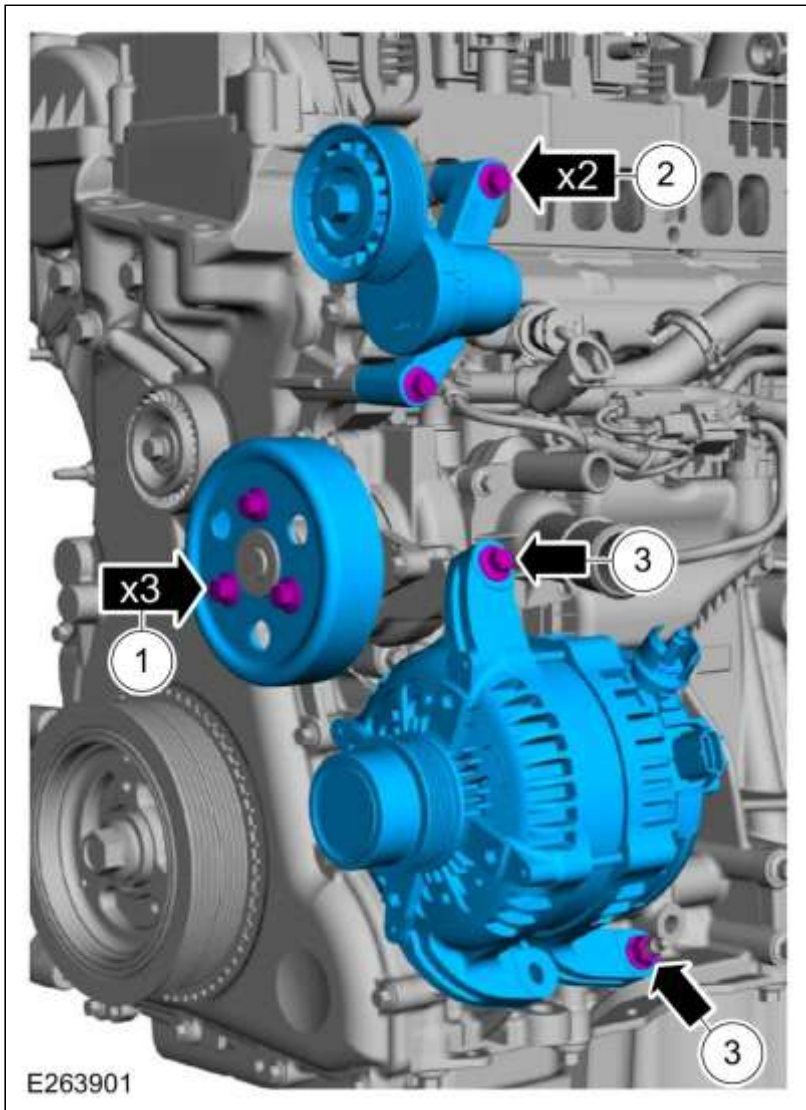

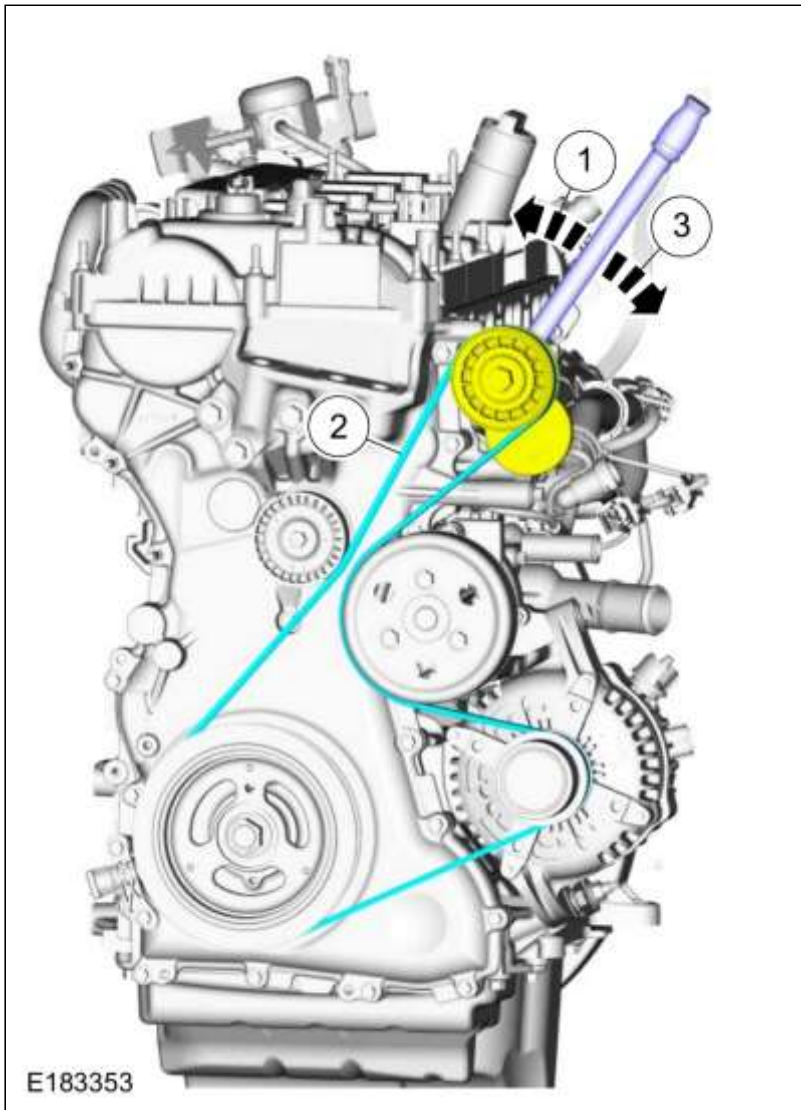

87. Koppel: 20 Nm

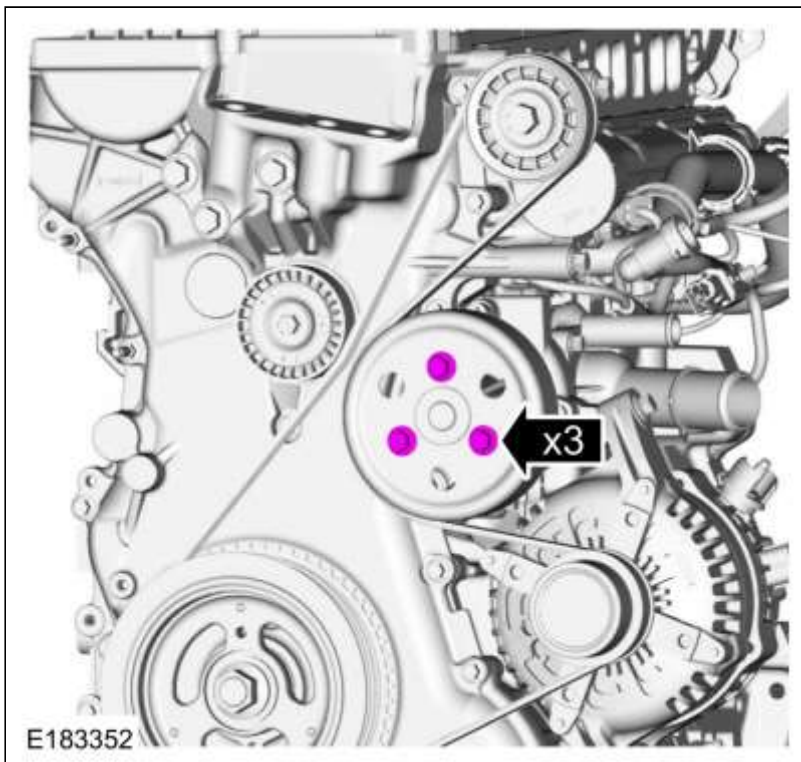

88. Koppel: 17 Nm

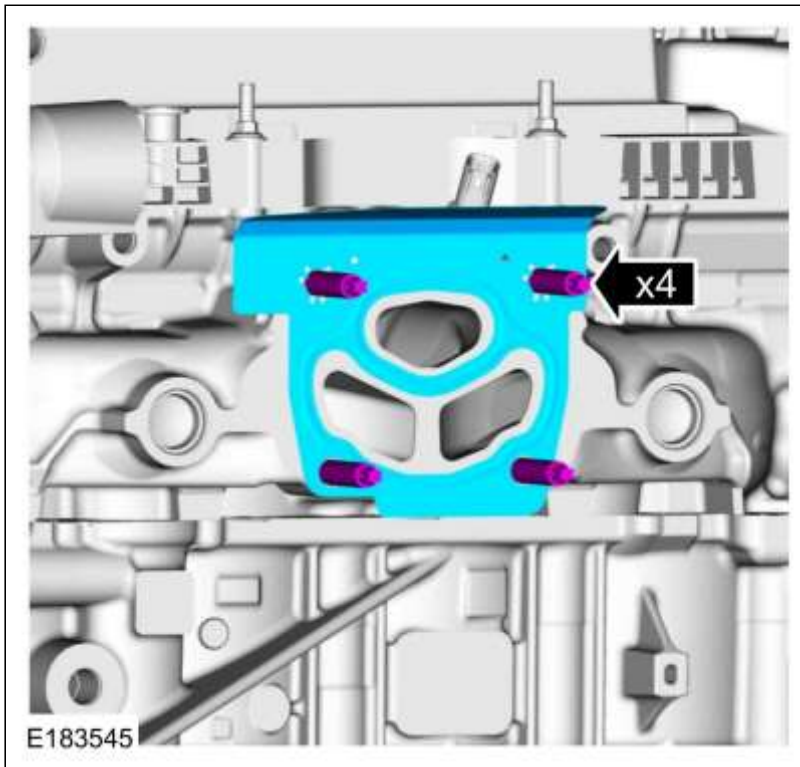

89. *Koppel:* 50 Nm

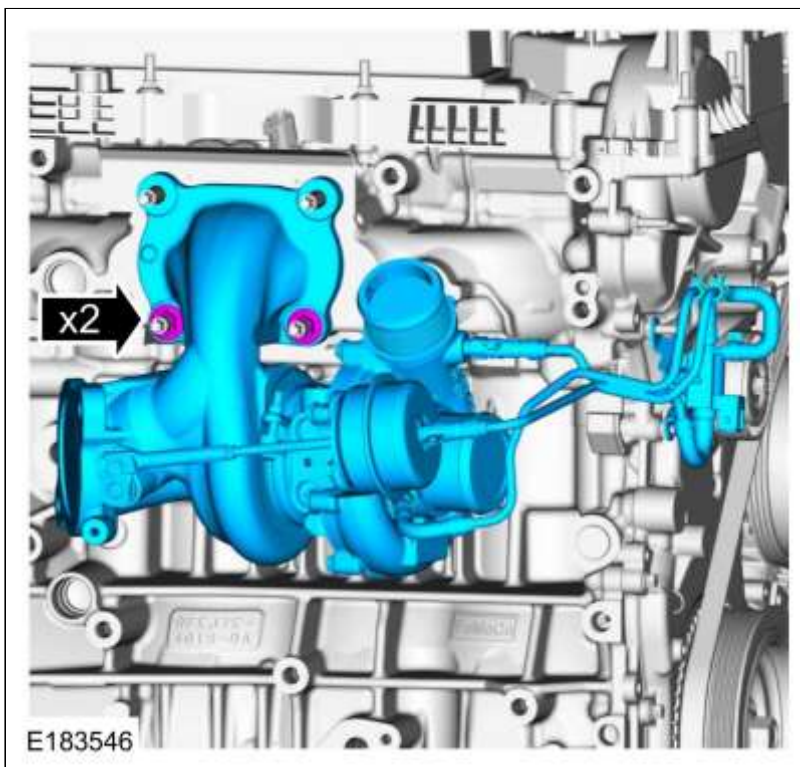

90. *Koppel:* 10 Nm

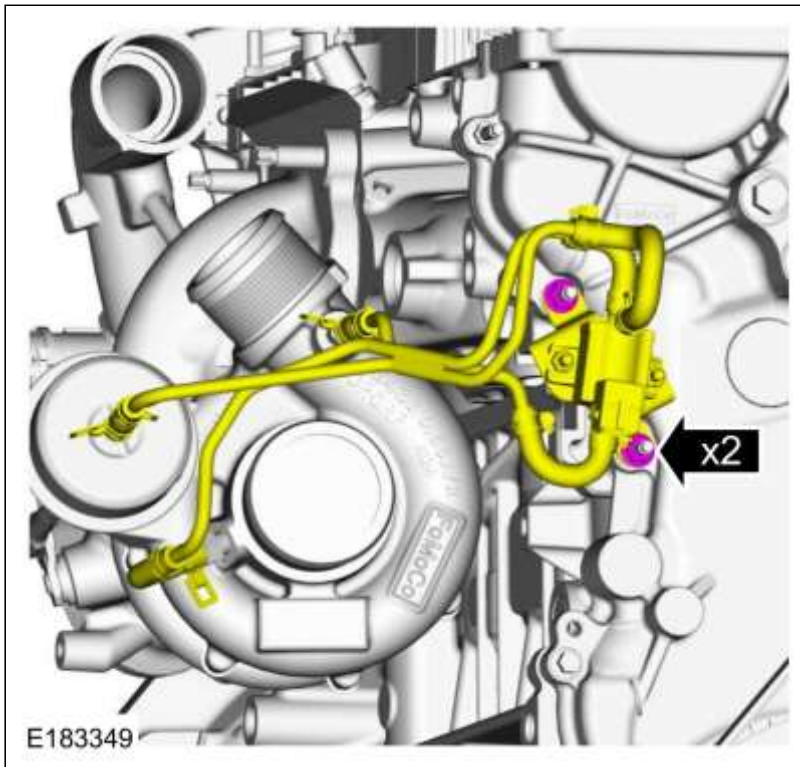

91.

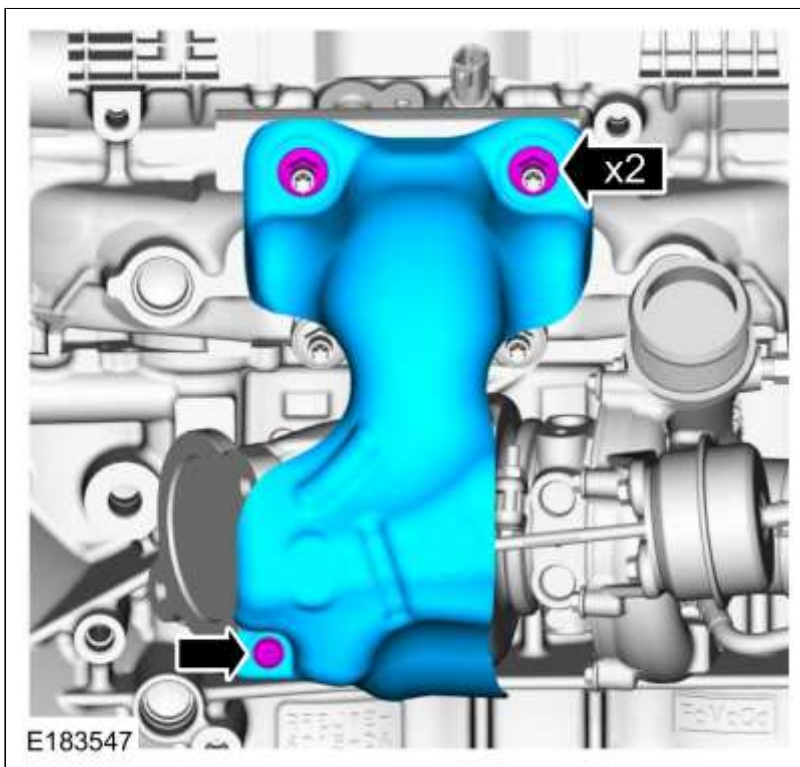

92. 1. Koppel: 50 Nm
2. Koppel: 10 Nm

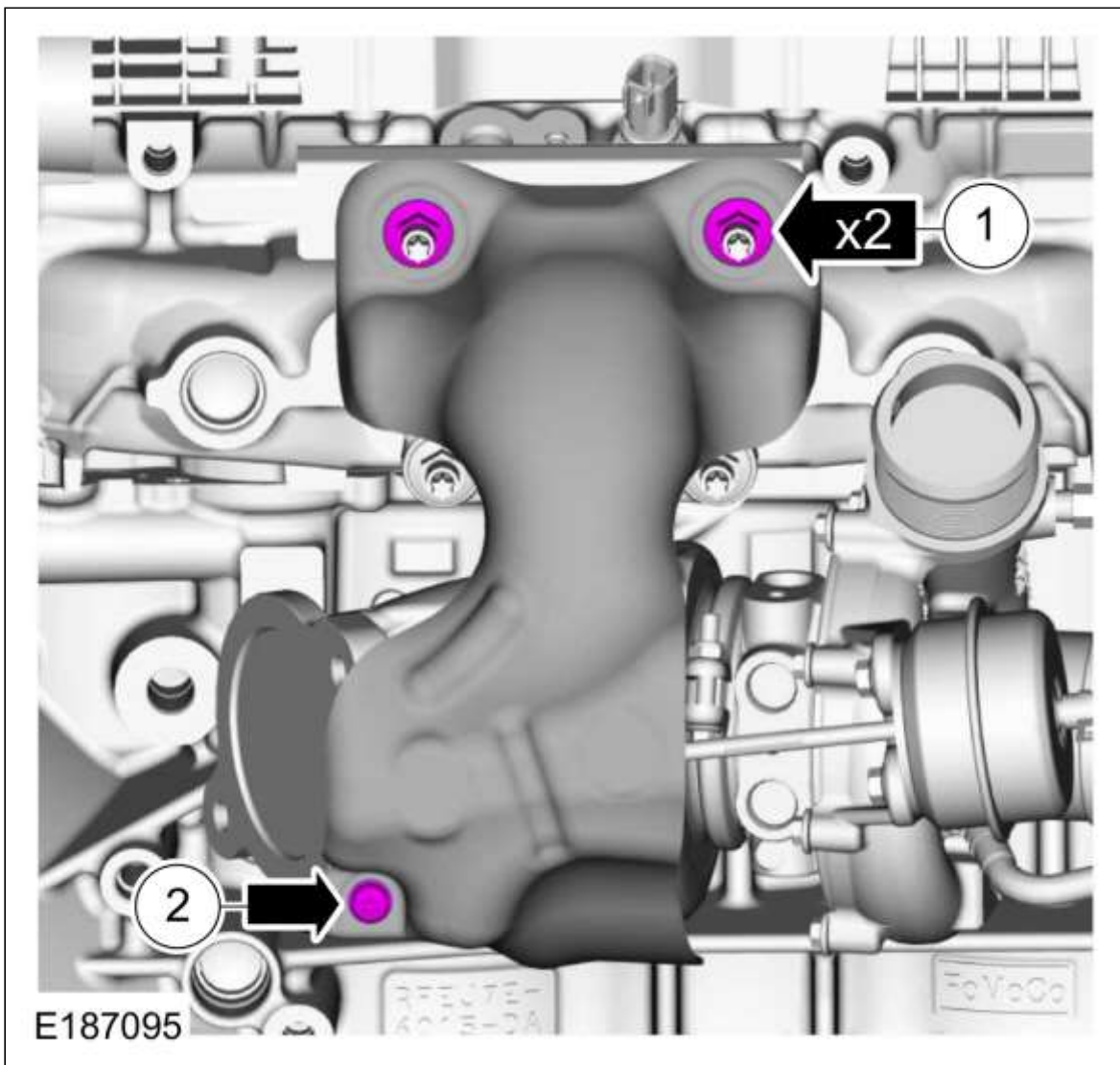

93. **N.B.:** Zorg dat een nieuw onderdeel wordt aangebracht.

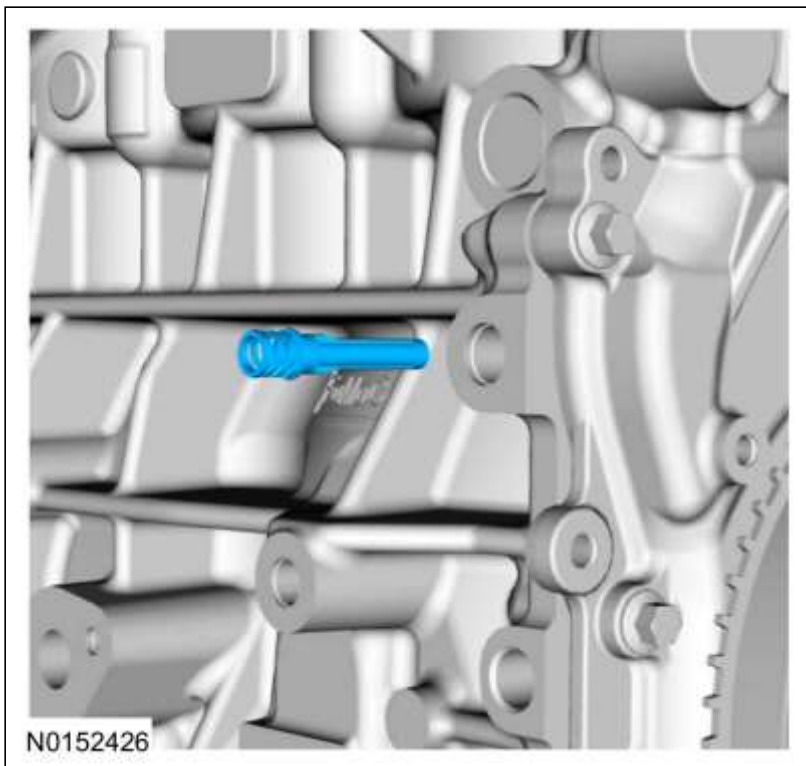

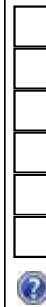
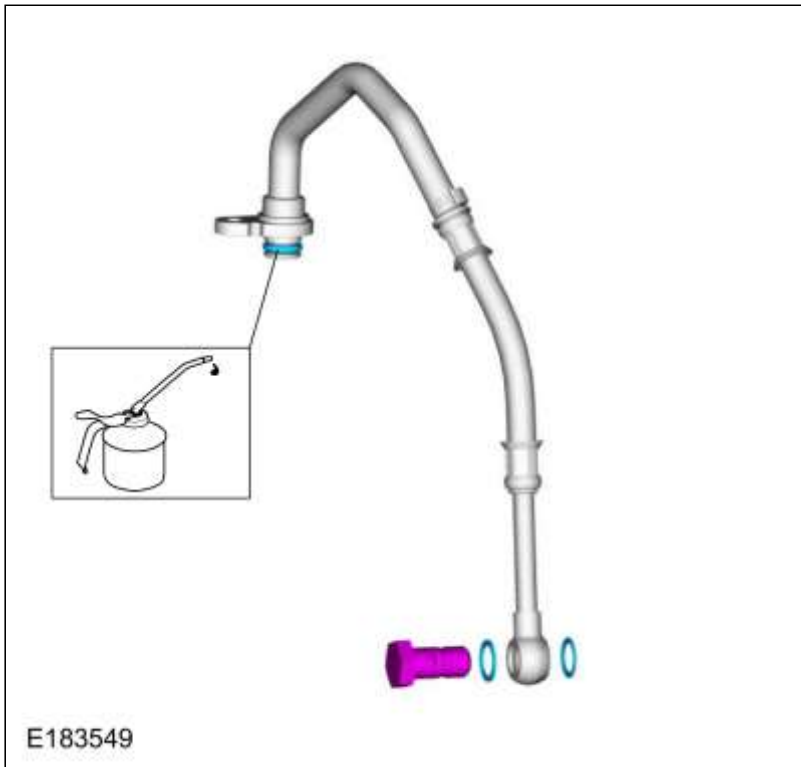

95. 1. Koppel: 10 Nm
2. Koppel: 25 Nm

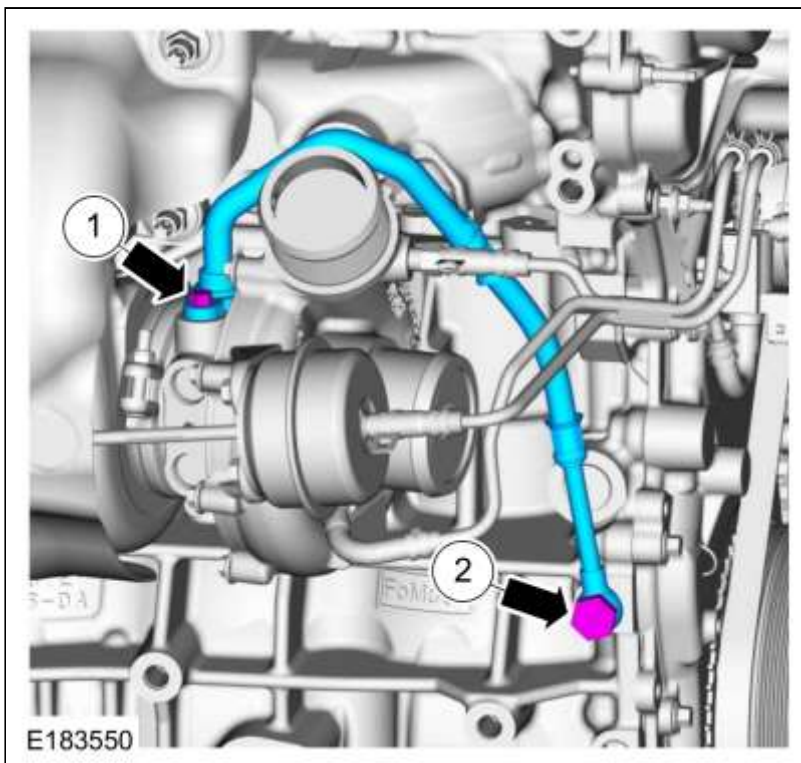

- 96.

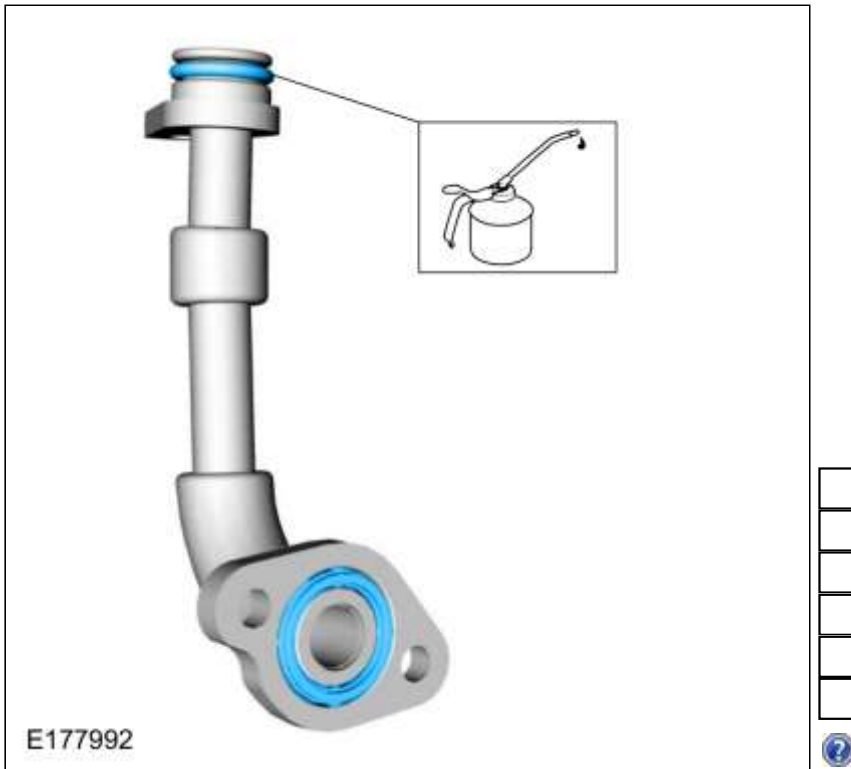

97. Koppel: 10 Nm

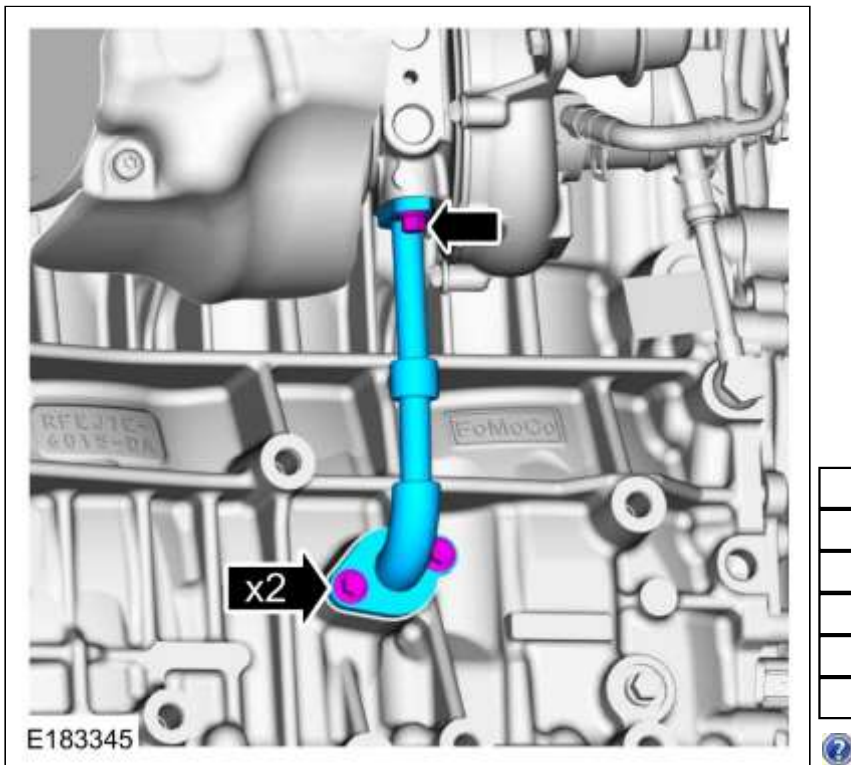

98.

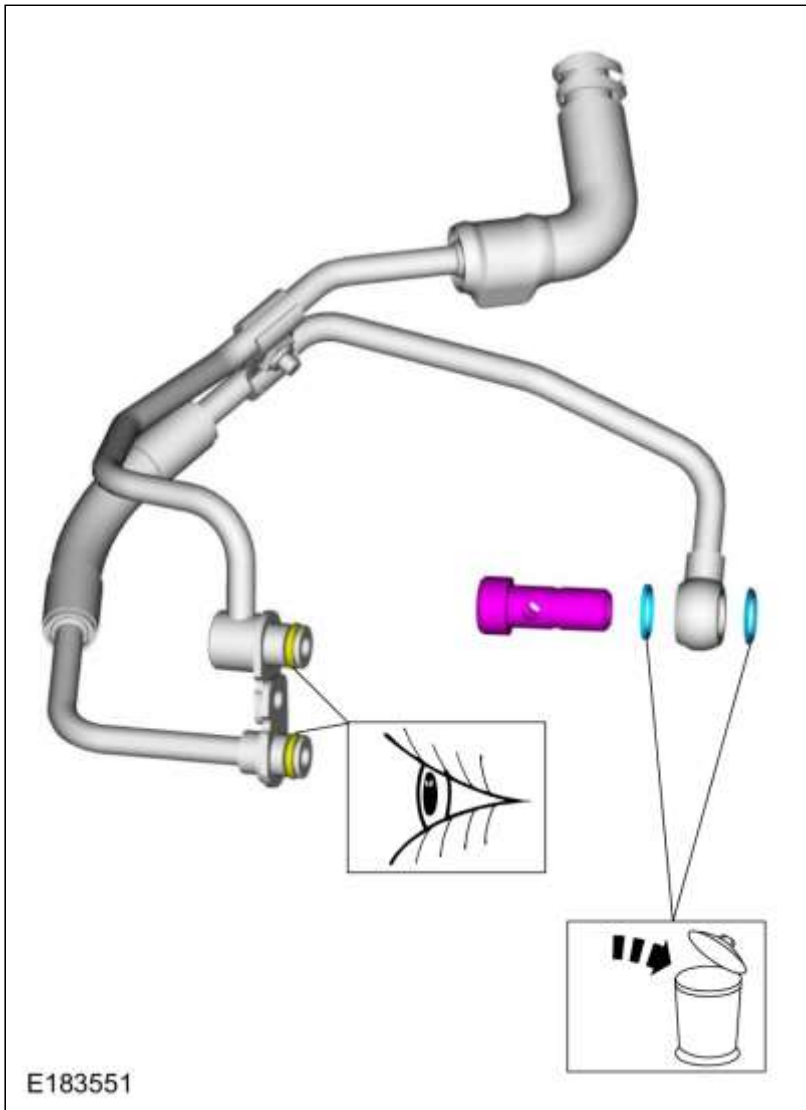

E183551

- 99. • *Materialen:* Koelmoeistof Super Plus Premium / FU7J-19544-xx (WSS-M97B44-D)
-

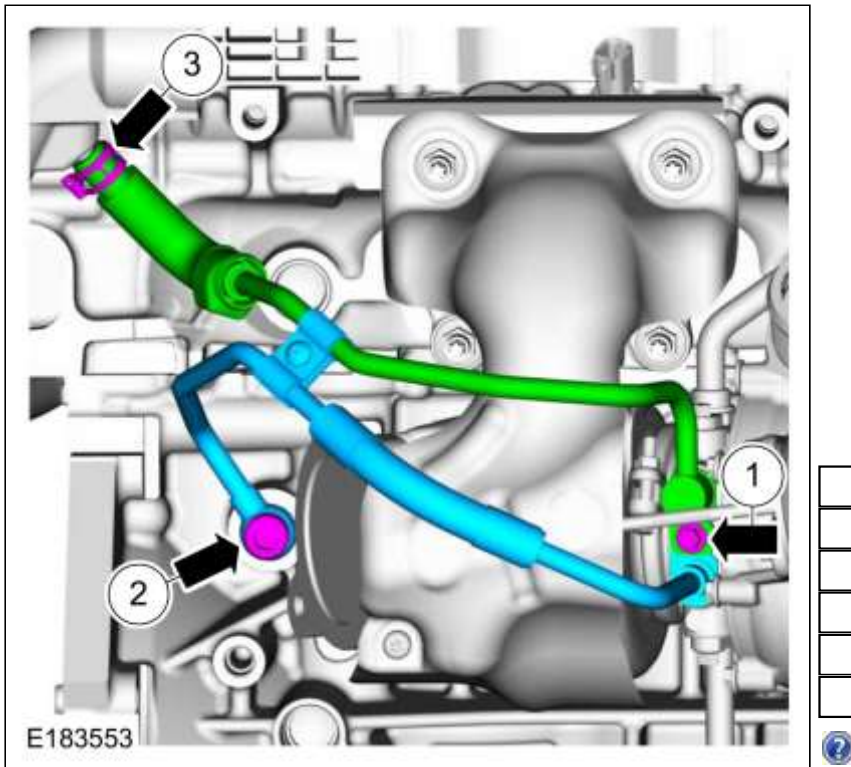

101. Algemene Uitrusting: Demontage-/montagegereedschap slangklemmen

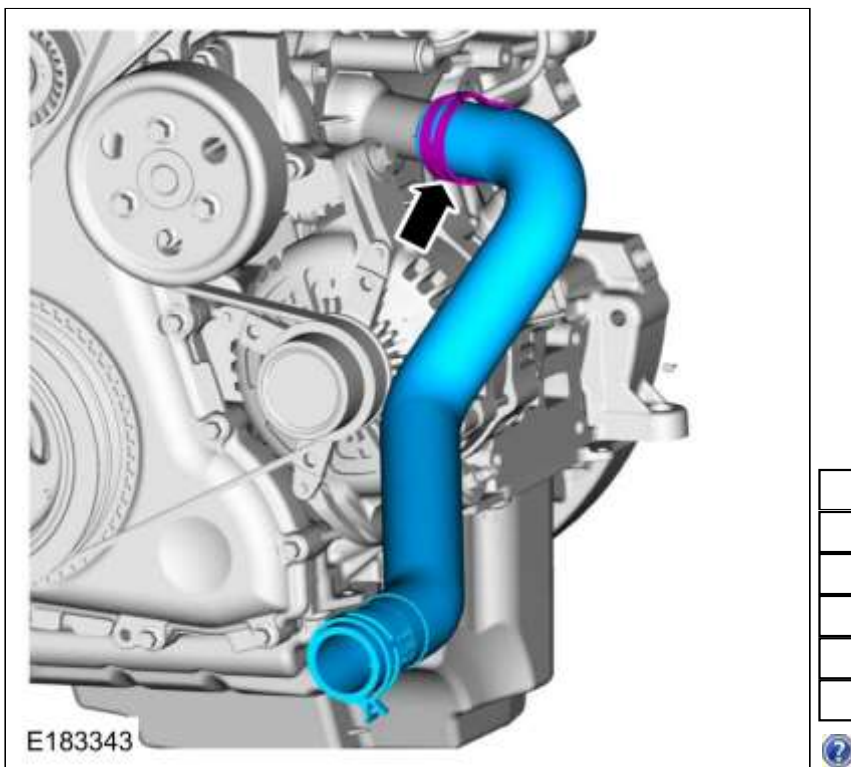

- 102.
- *Koppel:* 13 Nm
 - Algemene Uitrusting: Demontage-/montagegereedschap slangklemmen

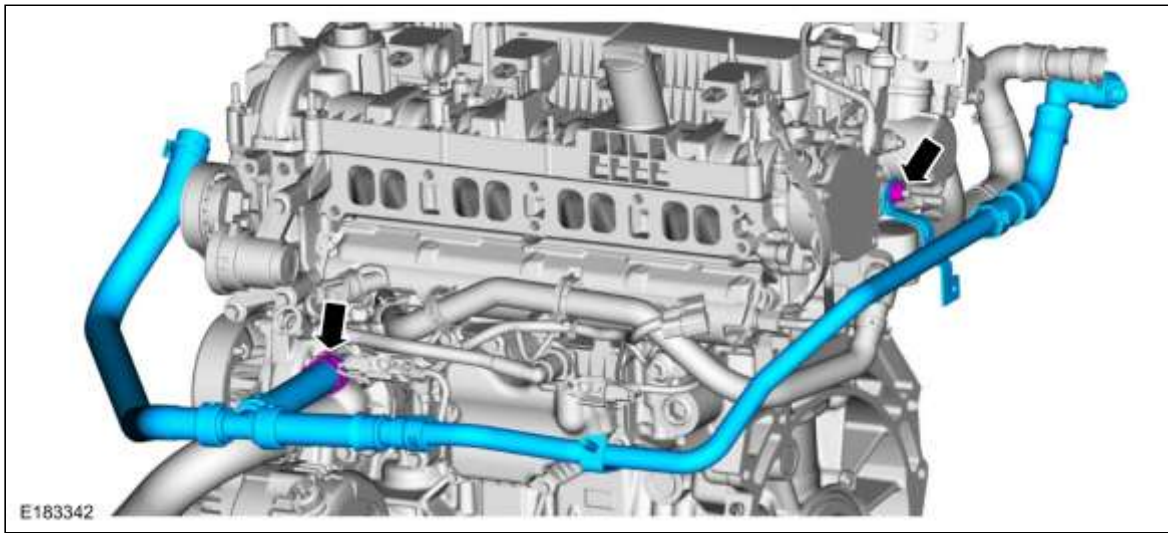

103.

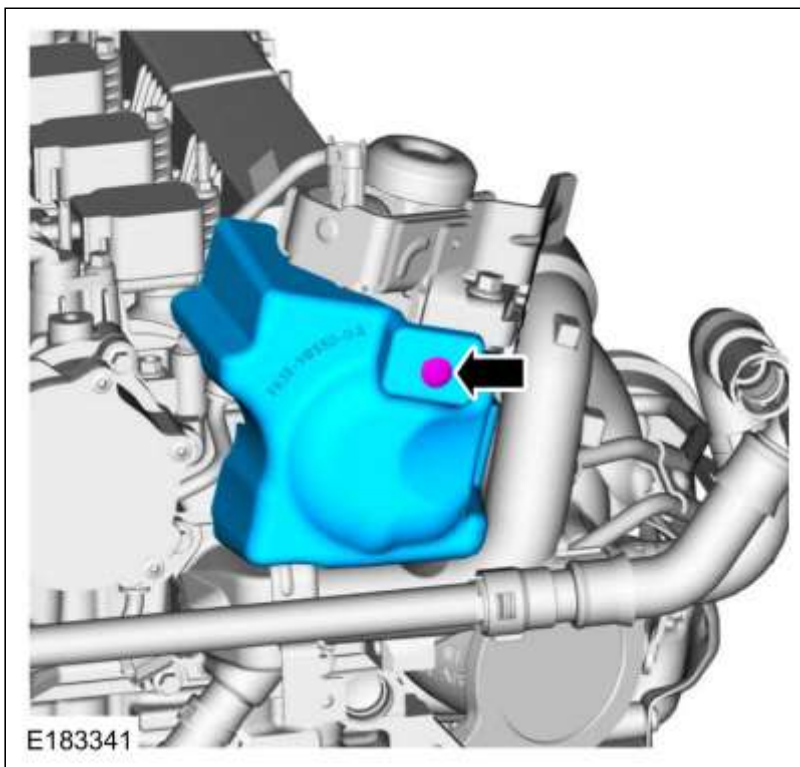

104.

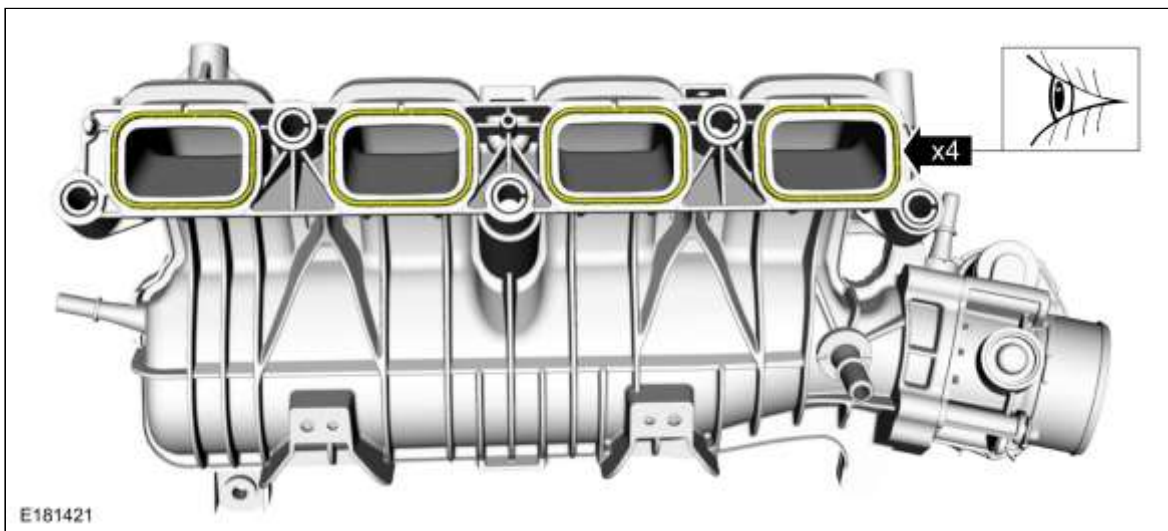

105.

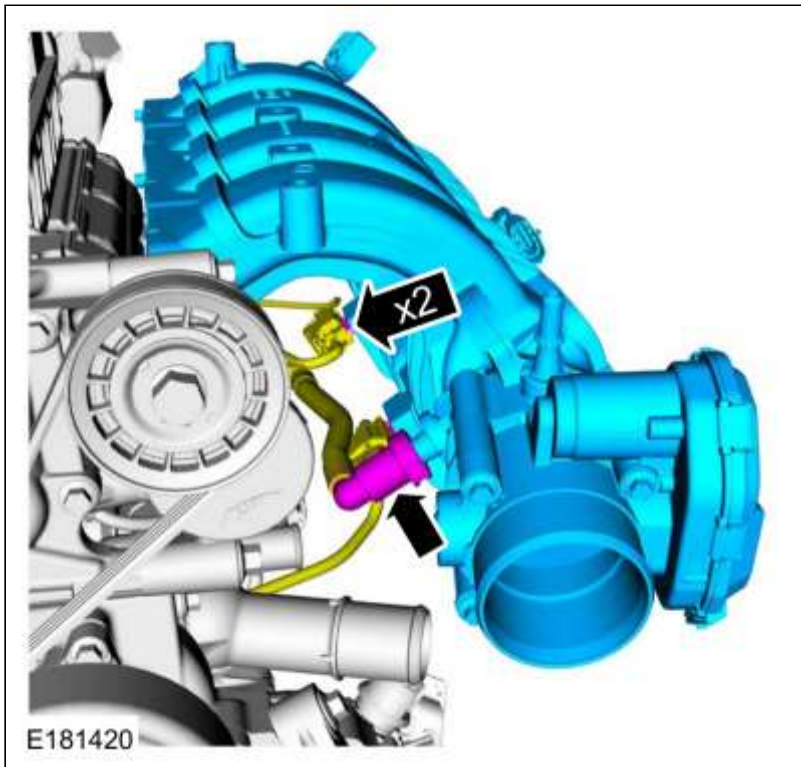

106. Koppel: 20 Nm

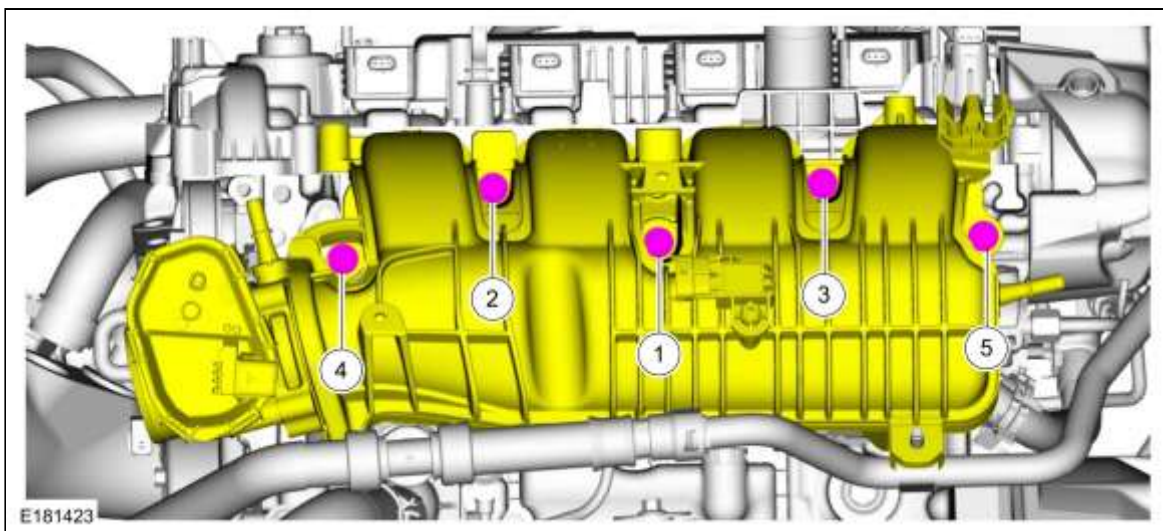

107. Koppel: 20 Nm

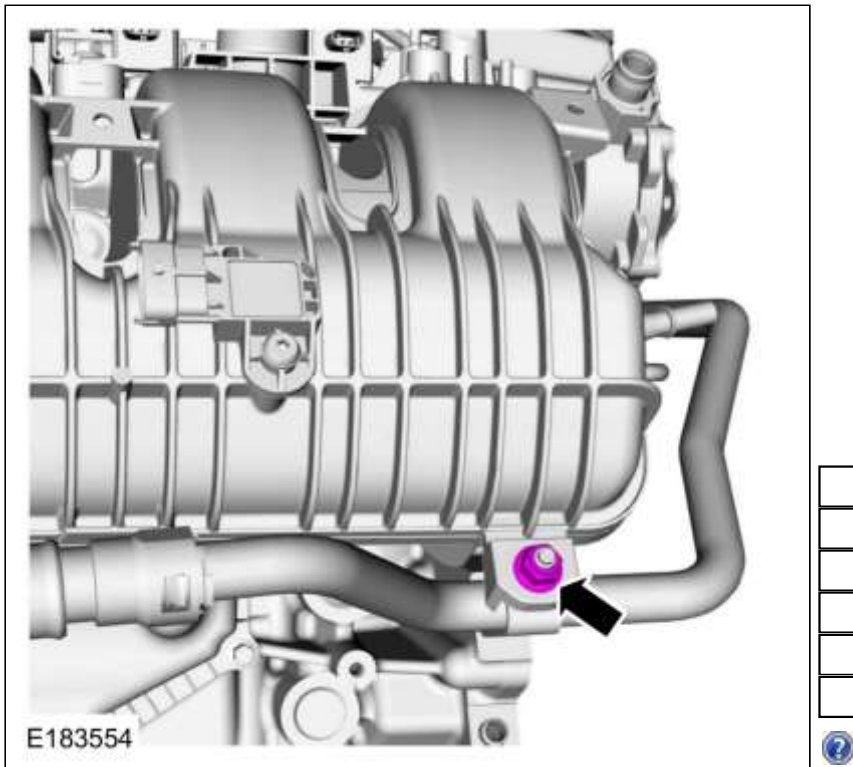

108.

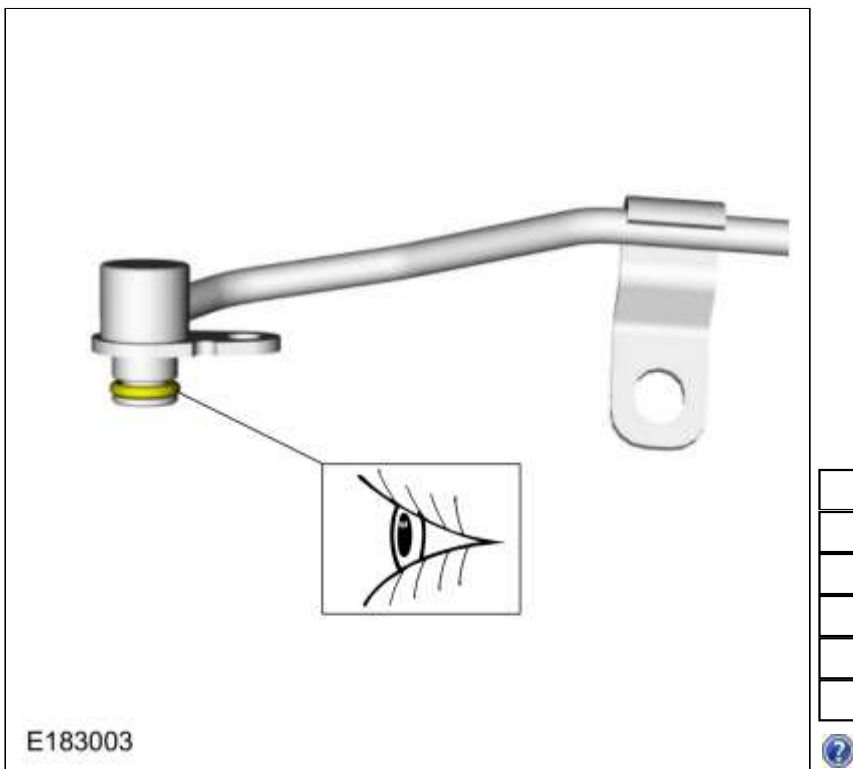

109. *Materialen:* Koelmoeistof Super Plus Premium / FU7J-19544-xx (WSS-M97B44-D)

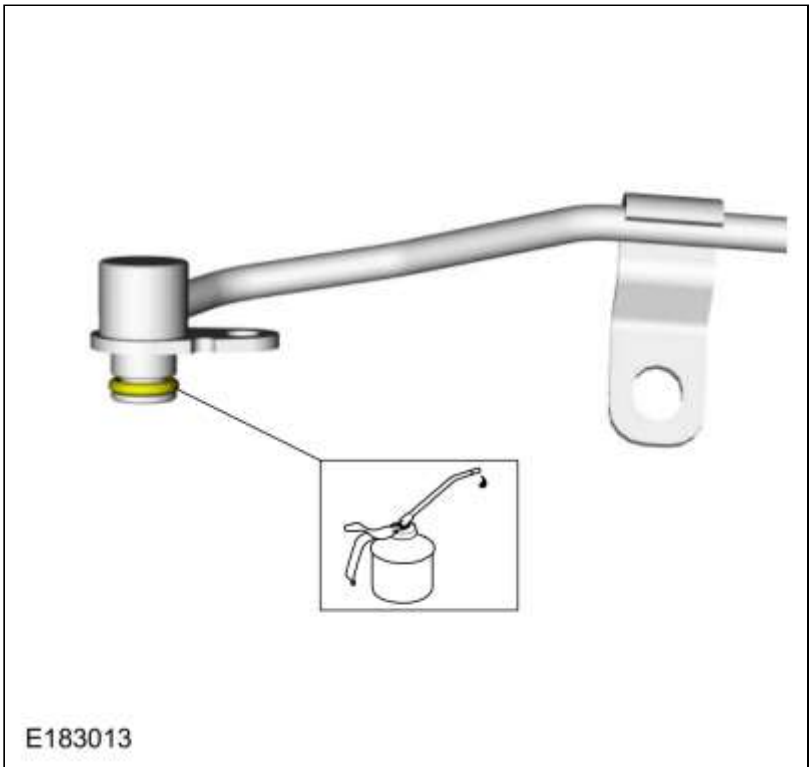

110. 1. Koppel: 11 Nm
2. Koppel: 30 Nm

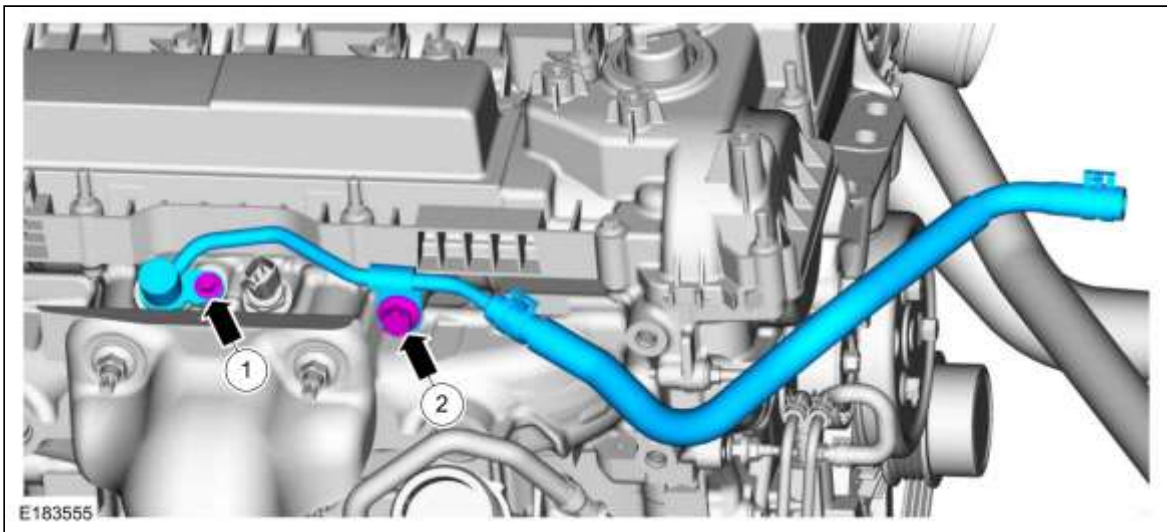

111. Koppel: 8 Nm

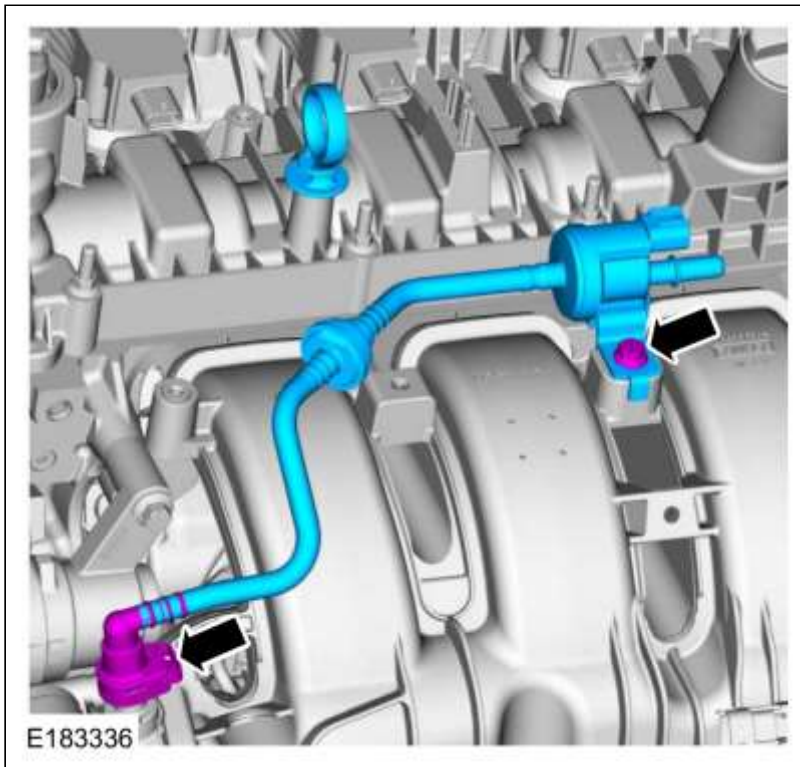

112.

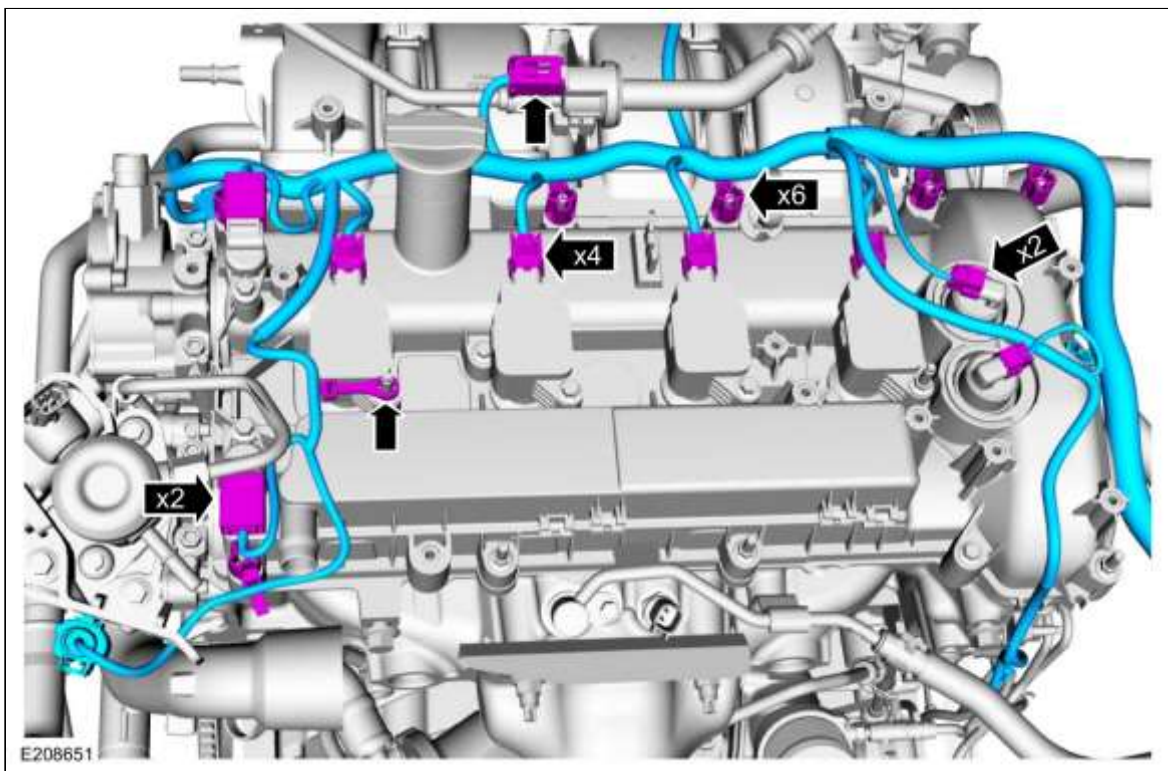

113.

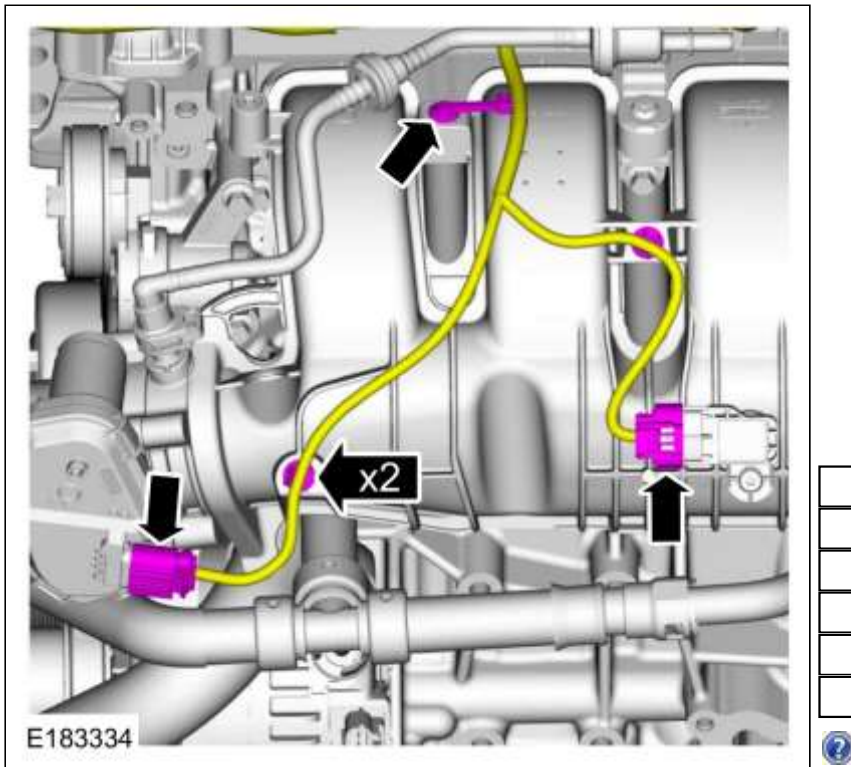

114.

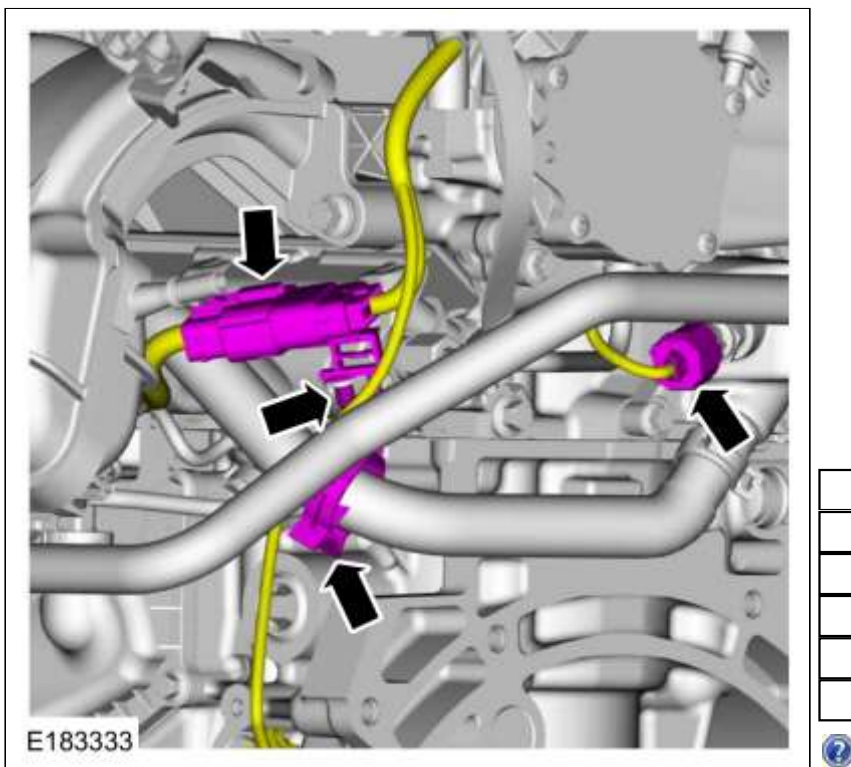

Automatische transmissie met 10 versnellingen - 10R80:

115.

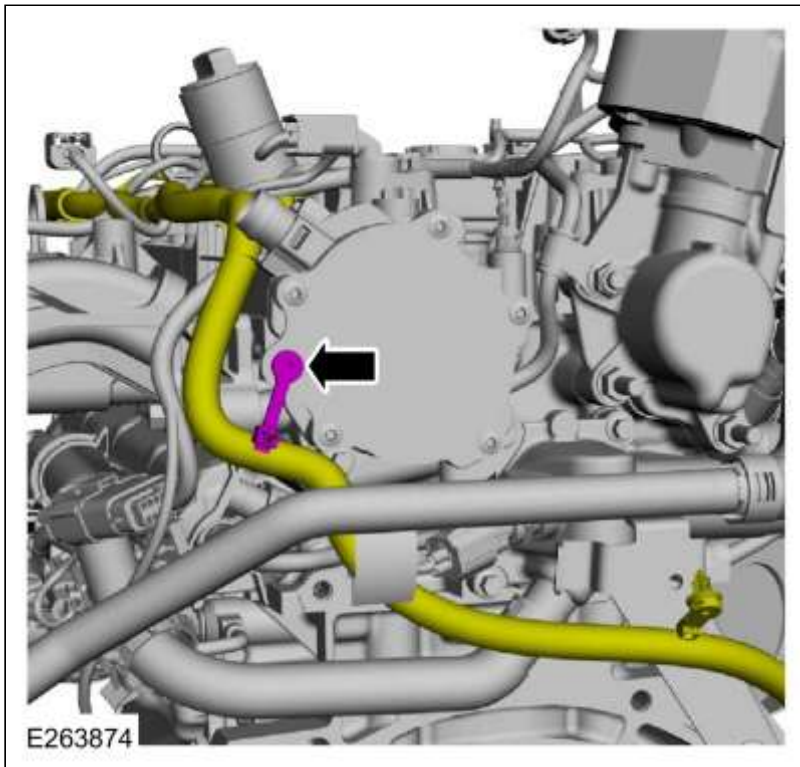

6-traps handgeschakelde versnellingsbak - MT82, Automatische transmissie met 10 versnellingen - 10R80:

116.

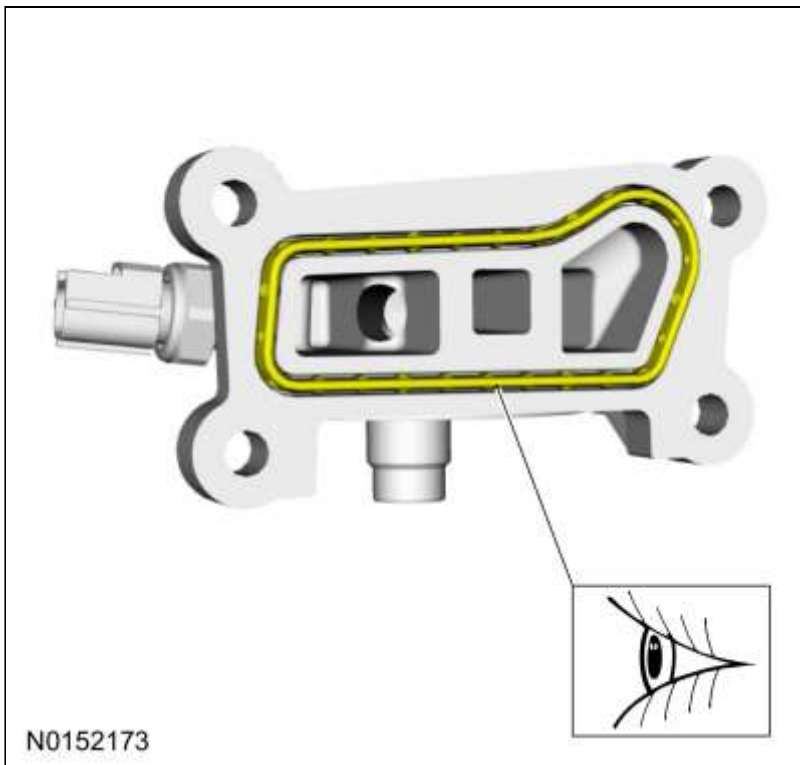

117. Koppel: 25 Nm

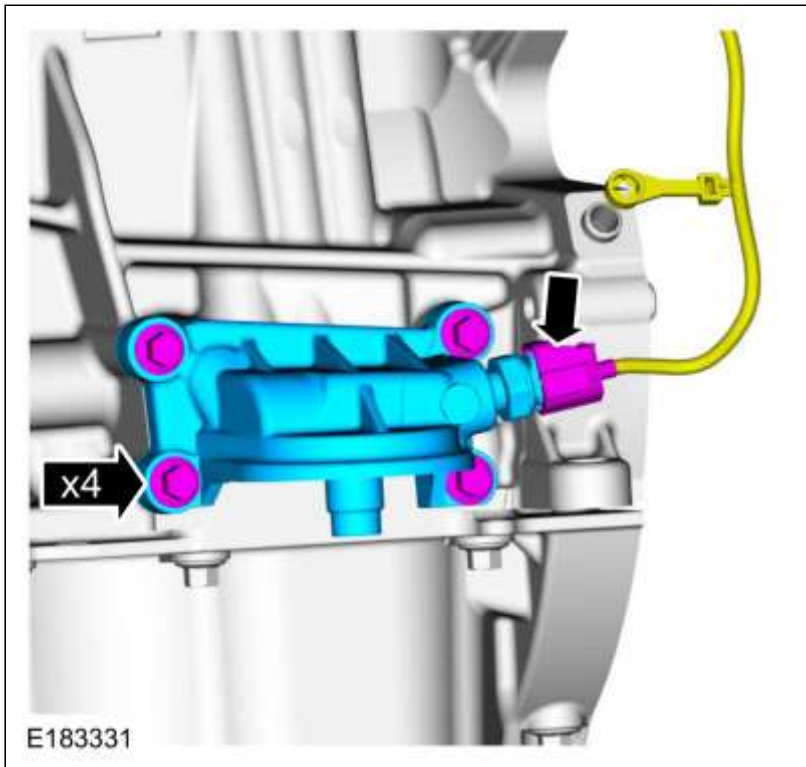

118.

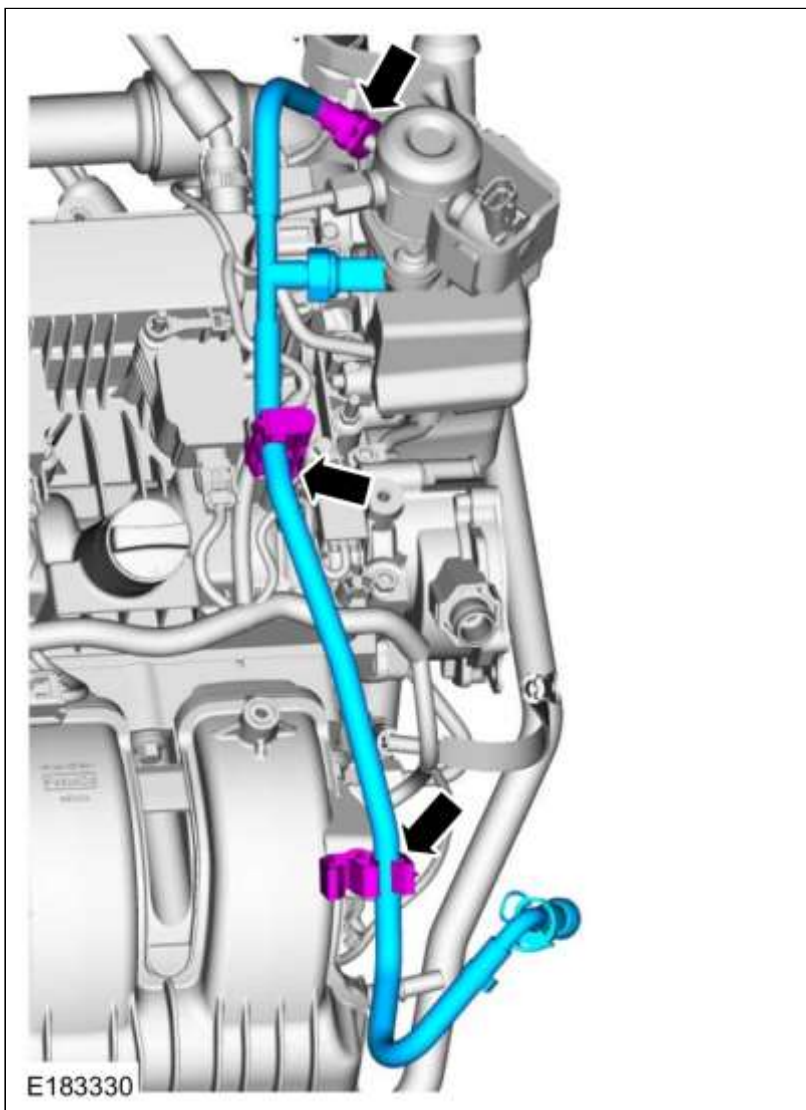

119.

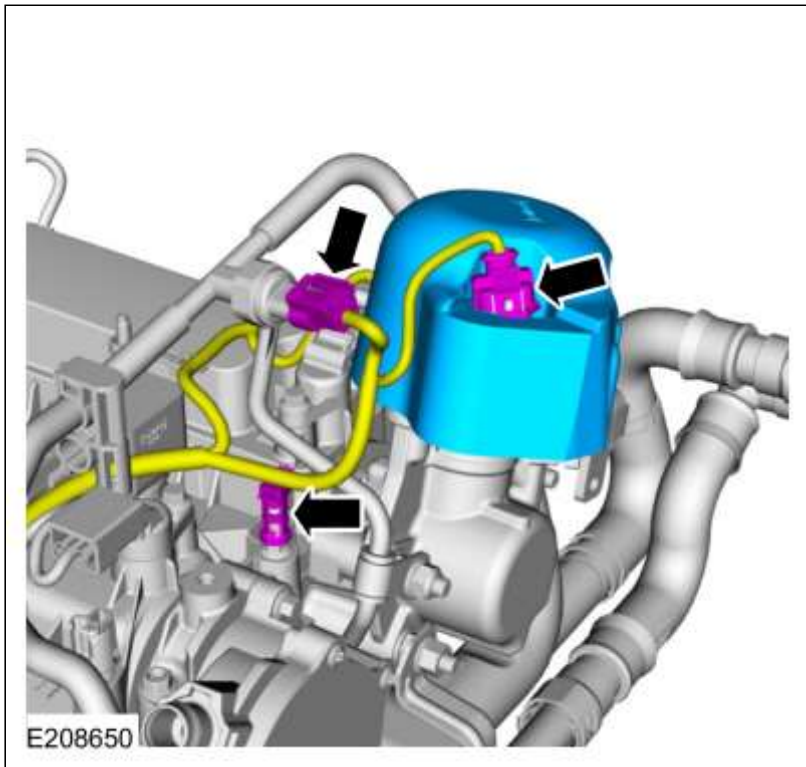

120.

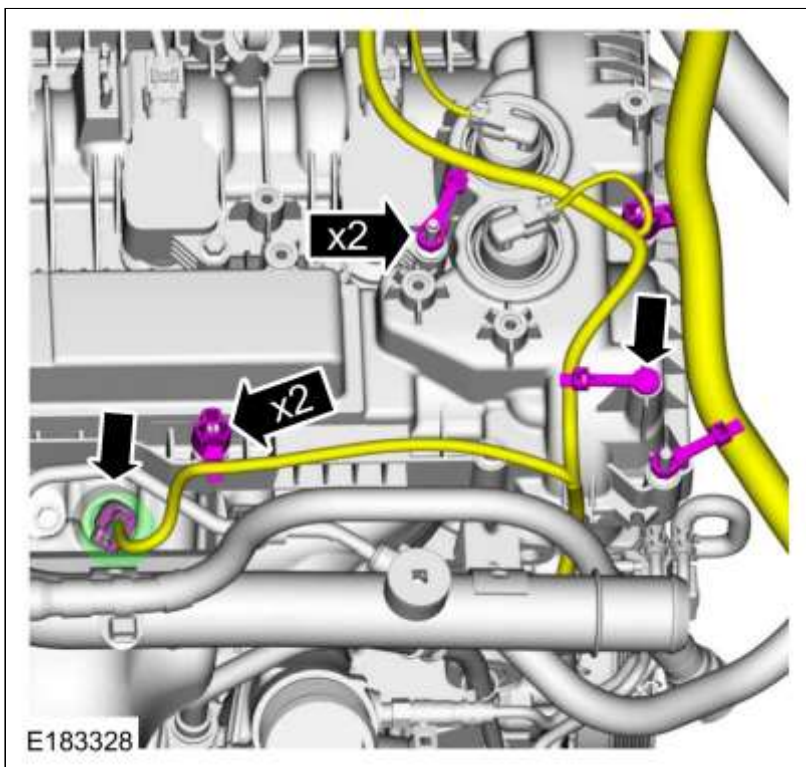

121. *Koppel:* 20 Nm

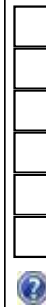
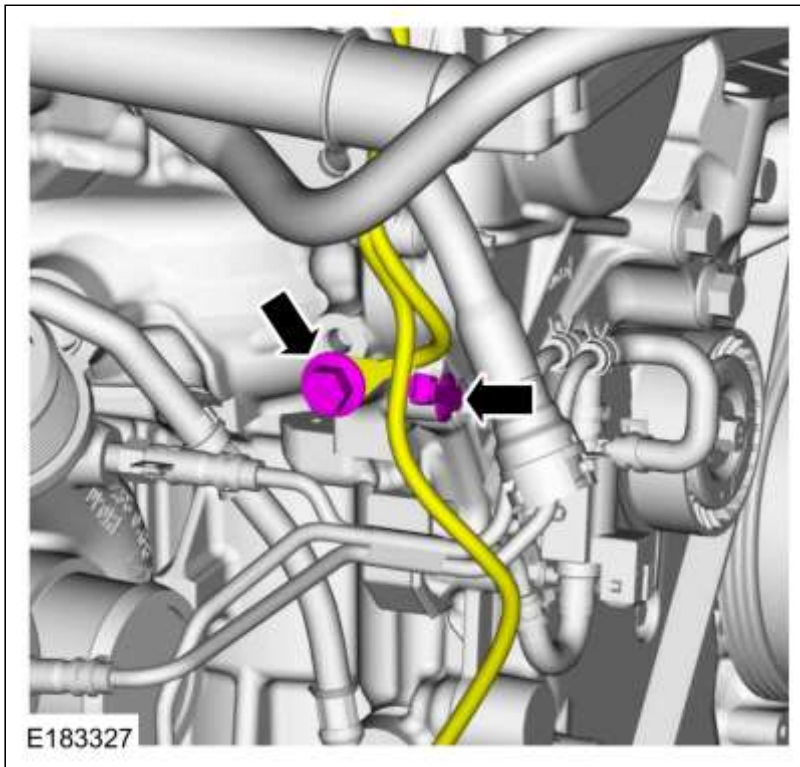

122.

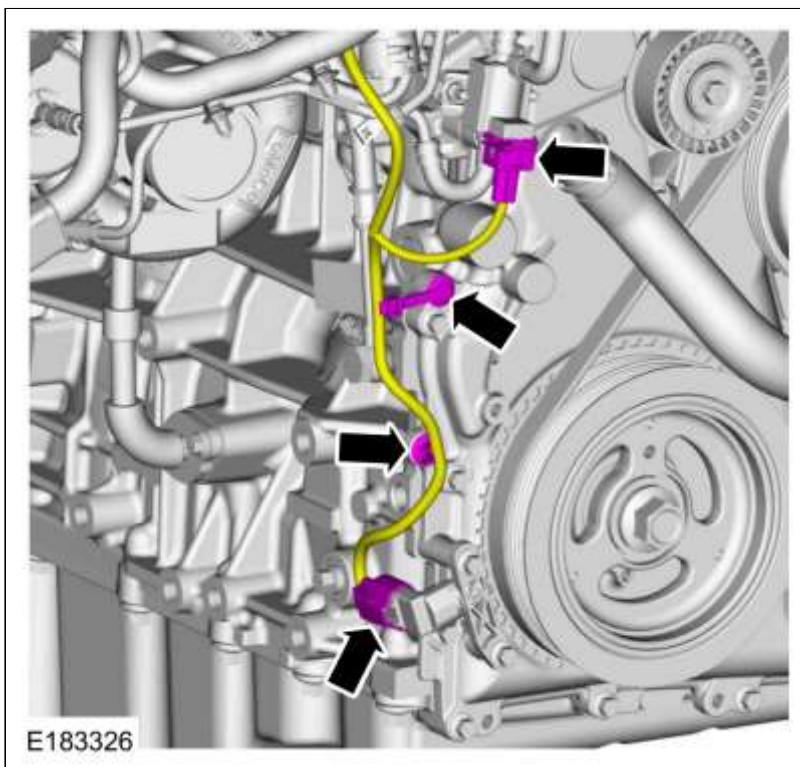

123. Speciaal gereedschap aanbrengen: 303-1626 Hijsogen, hoogspanningsaccu.

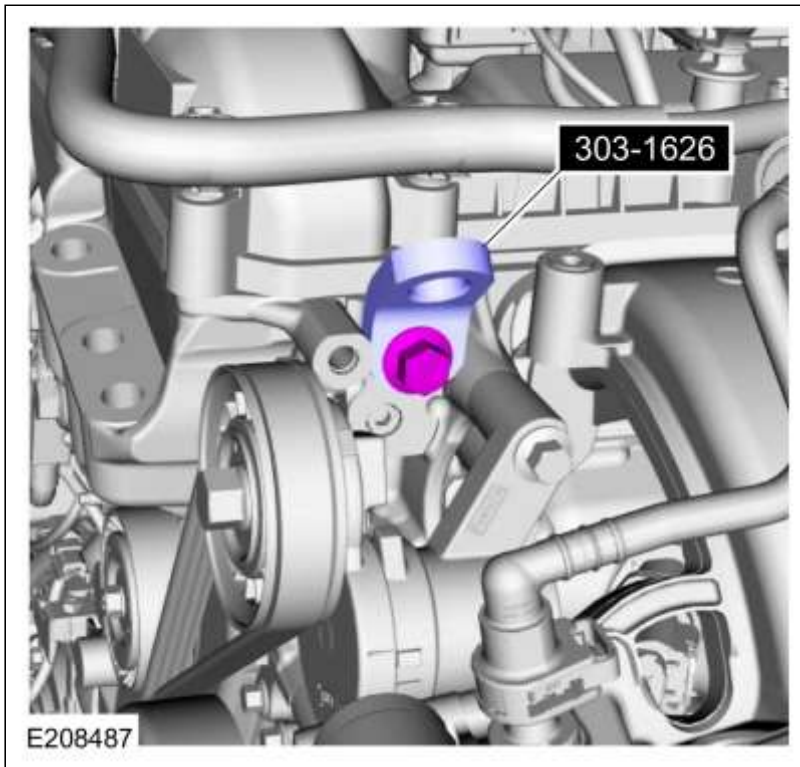

124. Speciaal gereedschap aanbrengen: 303-1626 Hijsogen, hoogspanningsaccu.

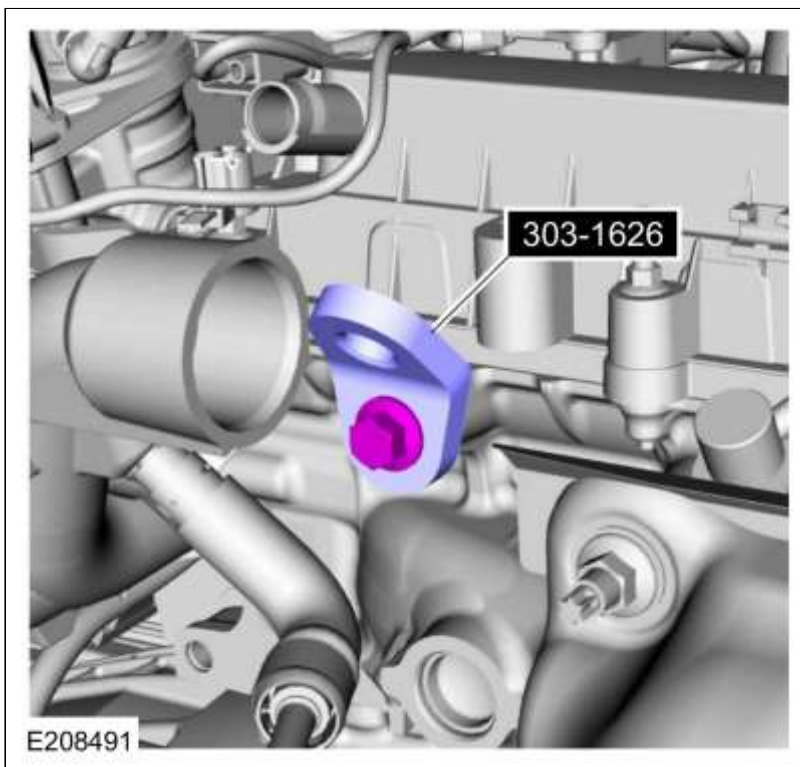

125. *Koppel*: 63 Nm

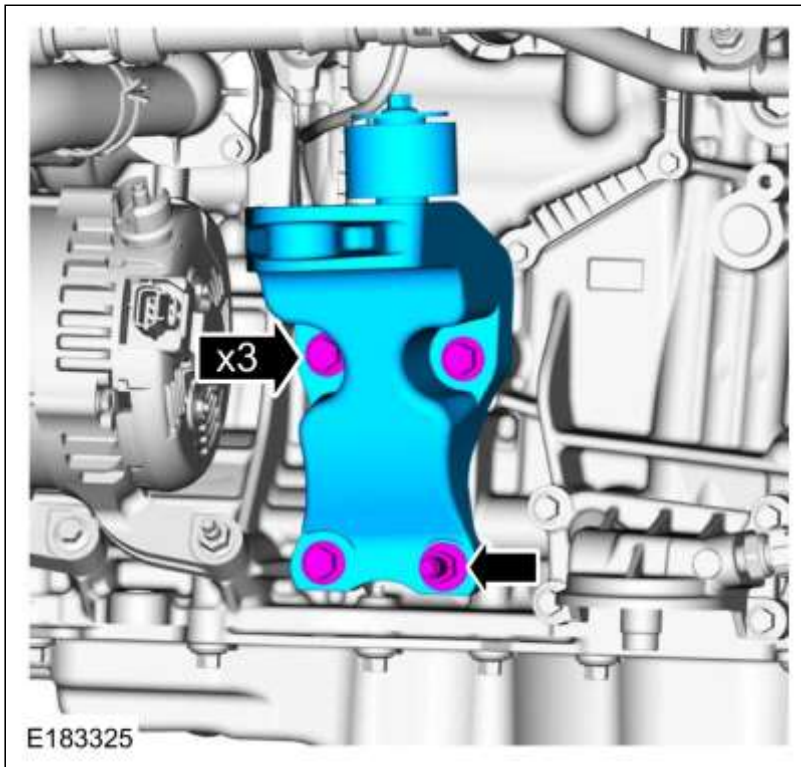

126. Koppel: 63 Nm

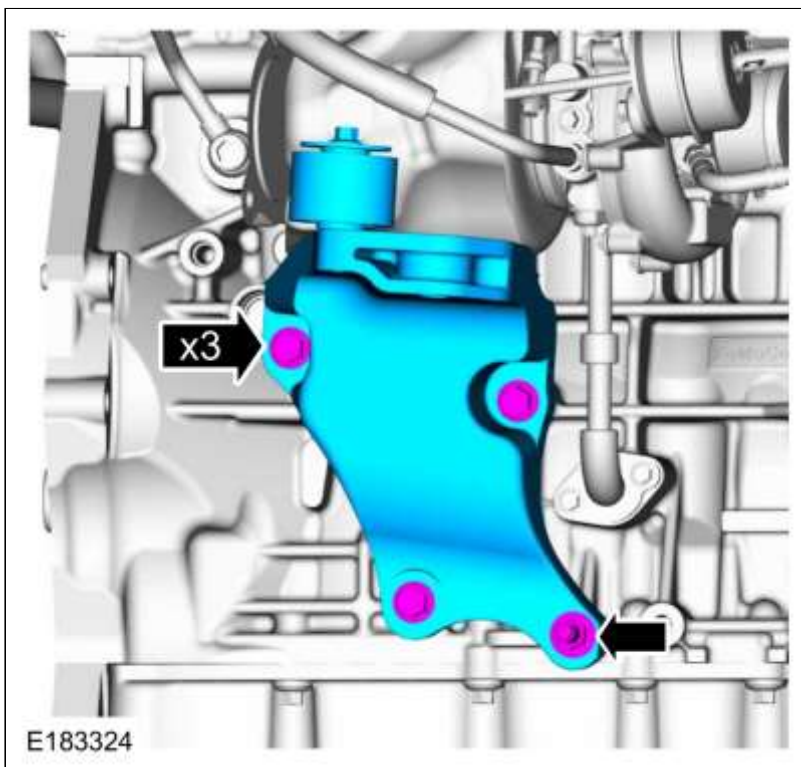

127. Koppel: 48 Nm

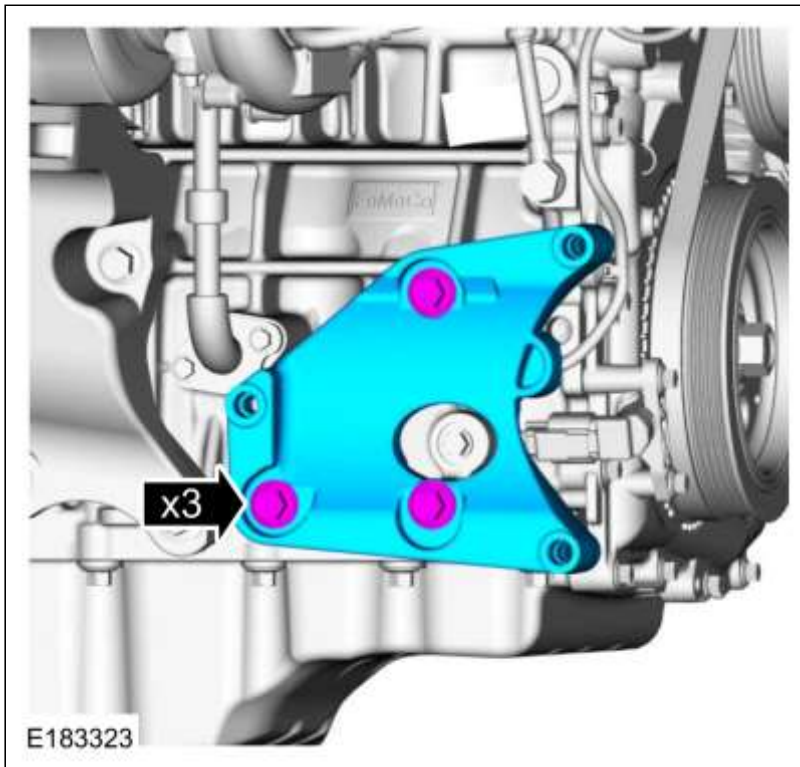

128. Algemene uitrusting aanbrengen: Vloerkraan
Algemene uitrusting aanbrengen: Hefbeugel

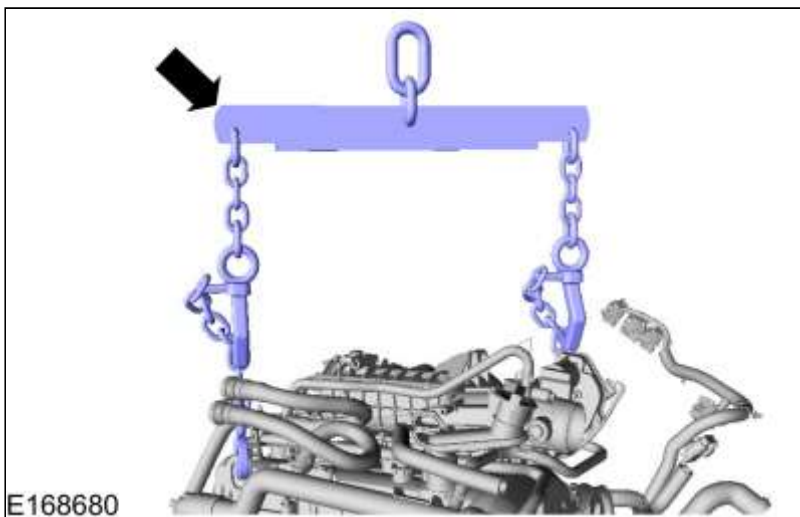

129. Aanbevolen gereedschap verwijderen: 303-435 Montagestandaard.

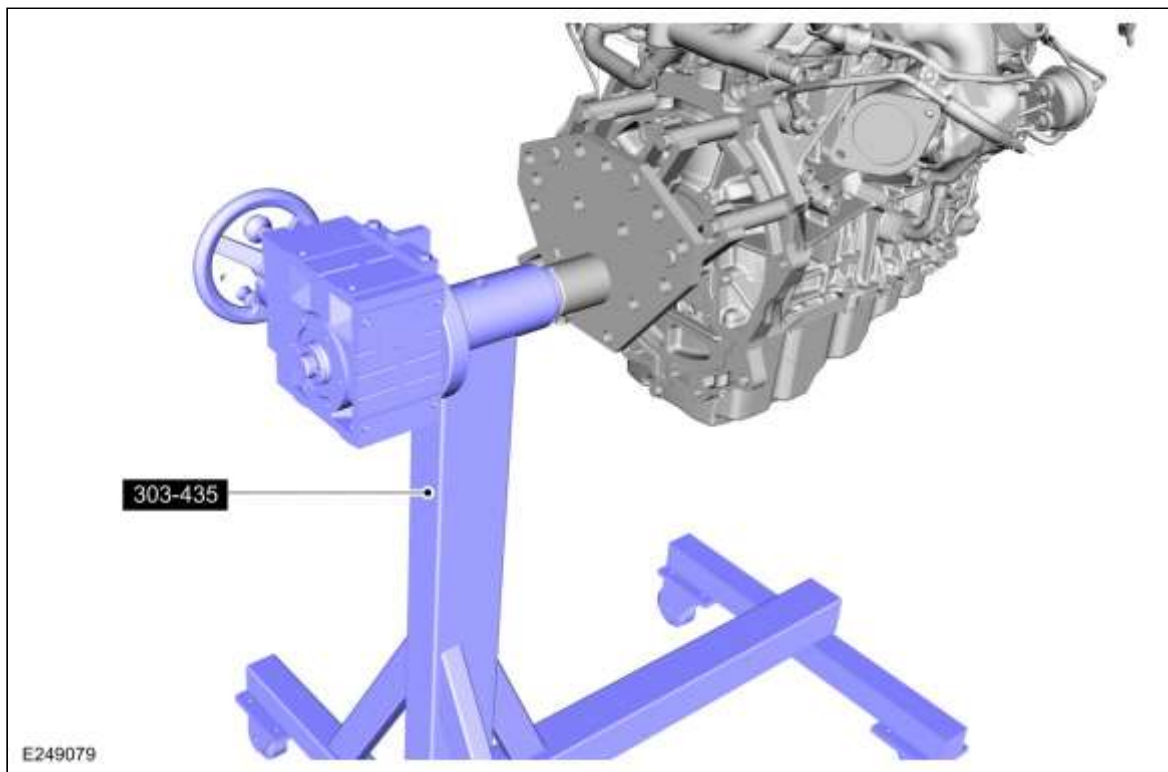

130. Aanbevolen gereedschap verwijderen: 303-1473 Mounting Plate, Engine.

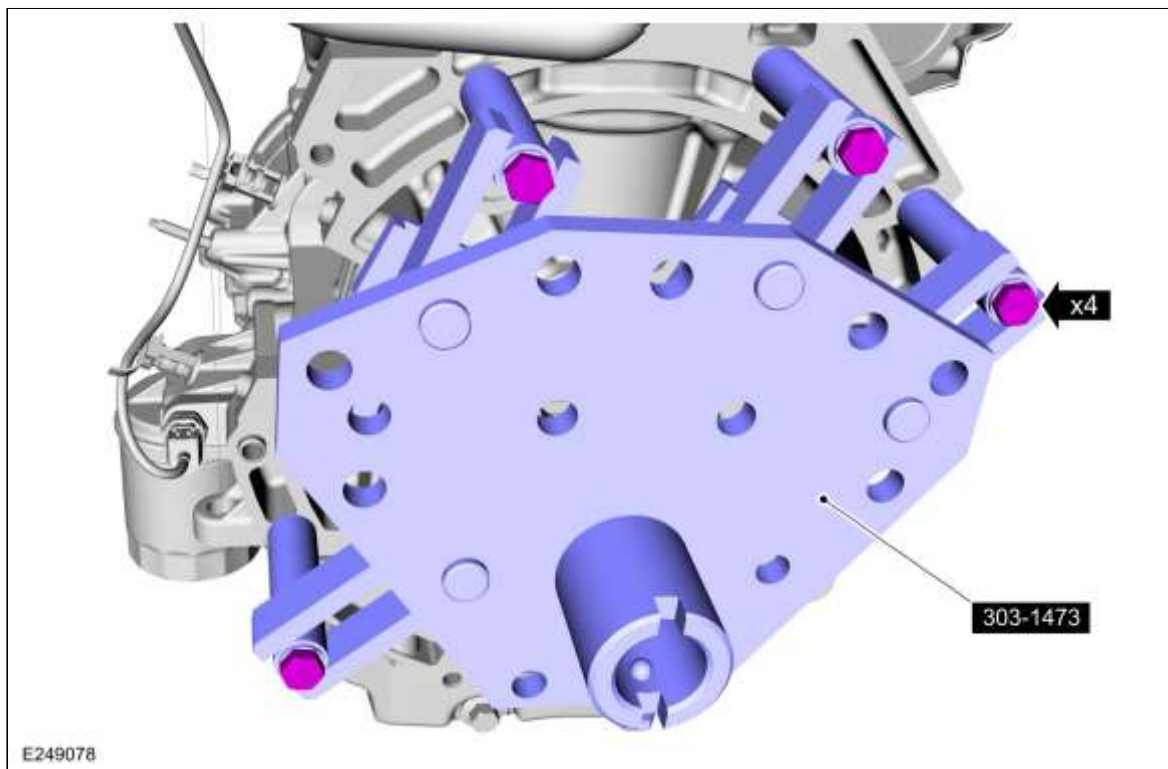

6-traps handgeschakelde versnellingsbak - MT82:

- 131.
- - Speciaal gereedschap aanbrengen: 303-254 Gereedschap om vliegwiel te vergrendelen.
 - *Koppel:*
 - Fase 1: 50 Nm
 - Fase 2: 80 Nm
 - Fase 3: 112 Nm

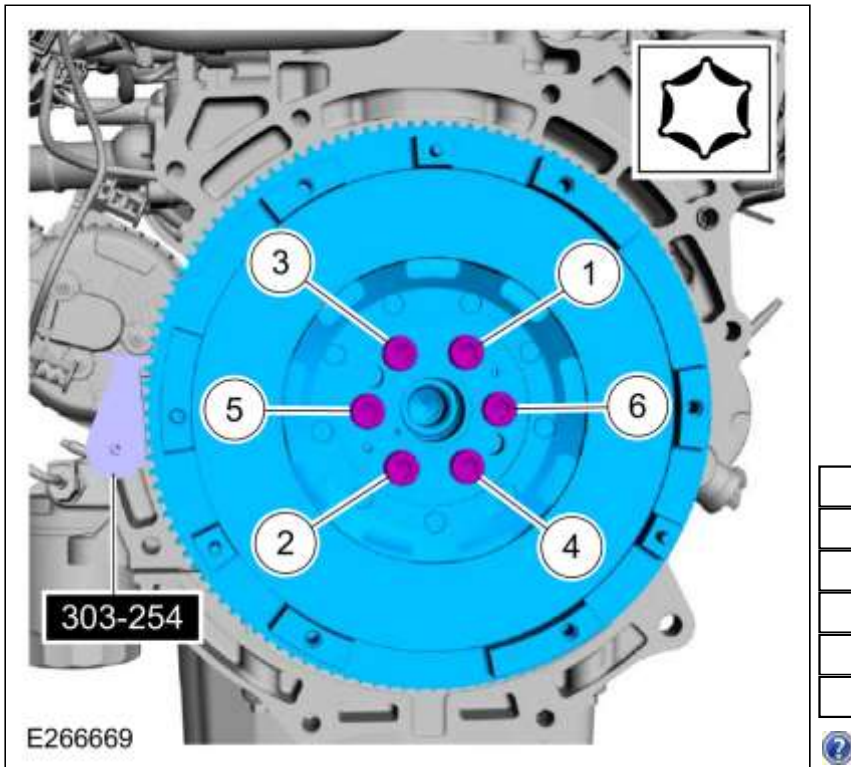

132. Algemene Uitrusting: Gereedschap uitlijning koppeling

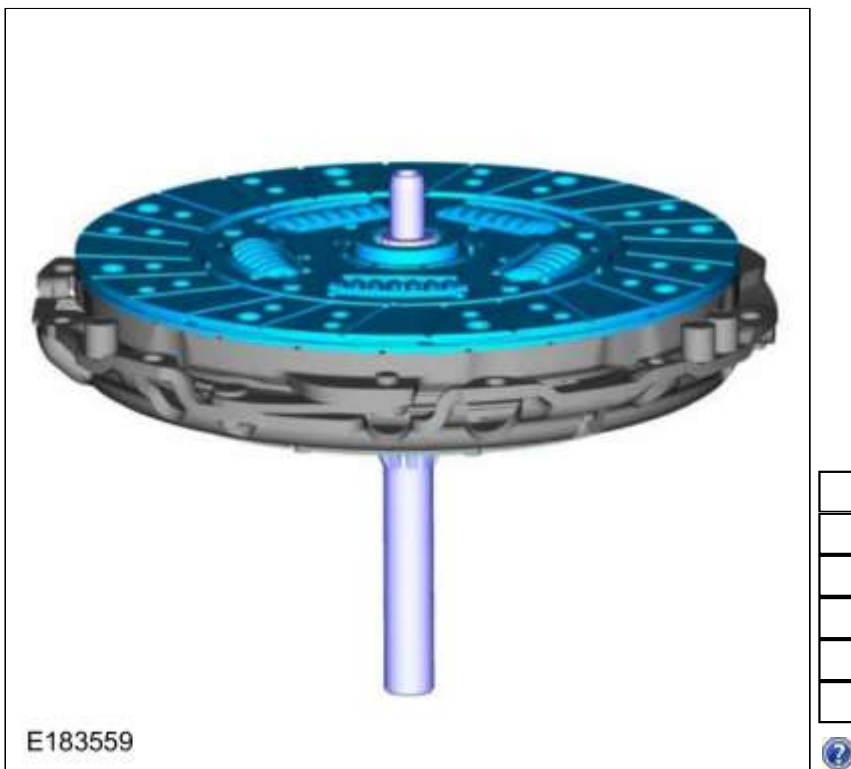

133. Algemene Uitrusting: Gereedschap uitlijning koppeling
Koppel: 35 Nm

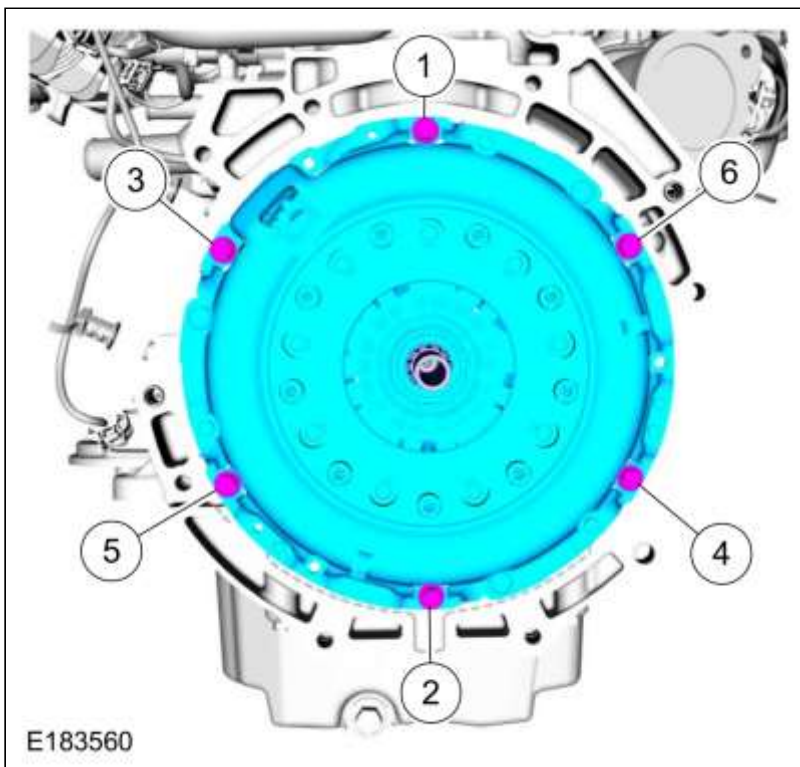

Automatische transmissie met 10 versnellingen - 10R80:

- 134.
- - Speciaal gereedschap aanbrengen: 303-254 Gereedschap om vliegwiel te vergrendelen.
 - *Koppel:*
 - Fase 1: 50 Nm
 - Fase 2: 80 Nm
 - Fase 3: 112 Nm

