

Kawasaki

Ninja ZX-6R



Motorcycle Service Manual

Quick Reference Guide

General Information	1
Fuel System	2
Cooling System	3
Engine Top End	4
Clutch	5
Engine Lubrication System	6
Engine Removal/Installation	7
Crankshaft/Transmission	8
Wheels/Tires	9
Final Drive	10
Brakes	11
Suspension	12
Steering	13
Frame	14
Electrical System	15
Appendix	16

This quick reference guide will assist you in locating a desired topic or procedure.

- Bend the pages back to match the black tab of the desired chapter number with the black tab on the edge at each table of contents page.
- Refer to the sectional table of contents for the exact pages to locate the specific topic required.



Kawasaki

Ninja ZX-6R

Motorcycle Service Manual

All rights reserved. No parts of this publication may be reproduced, stored in a retrieval system, or transmitted in any form or by any means, electronic mechanical photocopying, recording or otherwise, without the prior written permission of Quality Assurance Division/Consumer Products & Machinery Group/Kawasaki Heavy Industries, Ltd., Japan.

No liability can be accepted for any inaccuracies or omissions in this publication, although every possible care has been taken to make it as complete and accurate as possible.

The right is reserved to make changes at any time without prior notice and without incurring an obligation to make such changes to products manufactured previously. See your Motorcycle dealer for the latest information on product improvements incorporated after this publication.

All information contained in this publication is based on the latest product information available at the time of publication. Illustrations and photographs in this publication are intended for reference use only and may not depict actual model component parts.

LIST OF ABBREVIATIONS

A	ampere(s)	lb	pound(s)
ABDC	after bottom dead center	m	meter(s)
AC	alternating current	min	minute(s)
ATDC	after top dead center	N	newton(s)
BBDC	before bottom dead center	Pa	pascal(s)
BDC	bottom dead center	PS	horsepower
BTDC	before top dead center	psi	pound(s) per square inch
°C	degree(s) Celsius	r	revolution
DC	direct current	rpm	revolution(s) per minute
F	farad(s)	TDC	top dead center
°F	degree(s) Fahrenheit	TIR	total indicator reading
ft	foot, feet	V	volt(s)
g	gram(s)	W	watt(s)
h	hour(s)	Ω	ohm(s)
L	liter(s)		

Read OWNER'S MANUAL before operating.

EMISSION CONTROL INFORMATION

To protect the environment in which we all live, Kawasaki has incorporated crankcase emission (1) and exhaust emission (2) control systems in compliance with applicable regulations of the United States Environmental Protection Agency and California Air Resources Board. Additionally, Kawasaki has incorporated an evaporative emission control system (3) in compliance with applicable regulations of the California Air Resources Board on vehicles sold in California only.

1. Crankcase Emission Control System

This system eliminates the release of crankcase vapors into the atmosphere. Instead, the vapors are routed through an oil separator to the intake side of the engine. While the engine is operating, the vapors are drawn into combustion chamber, where they are burned along with the fuel and air supplied by the carburetion system.

2. Exhaust Emission Control System

This system reduces the amount of pollutants discharged into the atmosphere by the exhaust of this motorcycle. The fuel, ignition, and exhaust systems of this motorcycle have been carefully designed and constructed to ensure an efficient engine with low exhaust pollutant levels.

3. Evaporative Emission Control System

Vapors caused by fuel evaporation in the fuel system are not vented into the atmosphere. Instead, fuel vapors are routed into the running engine to be burned, or stored in a canister when the engine is stopped. Liquid fuel is caught by a vapor separator and returned to the fuel tank.

The Clean Air Act, which is the Federal law covering motor vehicle pollution, contains what is commonly referred to as the Act's "tampering provisions."

"Sec. 203(a) The following acts and the causing thereof are prohibited...

(3)(A) for any person to remove or render inoperative any device or element of design installed on or in a motor vehicle or motor vehicle engine in compliance with regulations under this title prior to its sale and delivery to the ultimate purchaser, or for any manufacturer or dealer knowingly to remove or render inoperative any such device or element of design after such sale and delivery to the ultimate purchaser.

(3)(B) for any person engaged in the business of repairing, servicing, selling, leasing, or trading motor vehicles or motor vehicle engines, or who operates a fleet of motor vehicles knowingly to remove or render inoperative any device or element of design installed on or in a motor vehicle or motor vehicle engine in compliance with regulations under this title following its sale and delivery to the ultimate purchaser..."

NOTE

○ *The phrase "remove or render inoperative any device or element of design" has been generally interpreted as follows:*

1. *Tampering does not include the temporary removal or rendering inoperative of devices or elements of design in order to perform maintenance.*
2. *Tampering could include:*
 - a. *Maladjustment of vehicle components such that the emission standards are exceeded.*
 - b. *Use of replacement parts or accessories which adversely affect the performance or durability of the motorcycle.*
 - c. *Addition of components or accessories that result in the vehicle exceeding the standards.*
 - d. *Permanently removing, disconnecting, or rendering inoperative any component or element of design of the emission control systems.*

WE RECOMMEND THAT ALL DEALERS OBSERVE THESE PROVISIONS OF FEDERAL LAW, THE VIOLATION OF WHICH IS PUNISHABLE BY CIVIL PENALTIES NOT EXCEEDING \$10,000 PER VIOLATION.

TAMPERING WITH NOISE CONTROL SYSTEM PROHIBITED

Federal law prohibits the following acts or the causing thereof: (1) The removal or rendering inoperative by any person other than for purposes of maintenance, repair, or replacement, of any device or element of design incorporated into any new vehicle for the purpose of noise control prior to its sale or delivery to the ultimate purchaser or while it is in use, or (2) the use of the vehicle after such device or element of design has been removed or rendered inoperative by any person.

Among those acts presumed to constitute tampering are the acts listed below:

- Replacement of the original exhaust system or muffler with a component not in compliance with Federal regulations.
- Removal of the muffler(s) or any internal portion of the muffler(s).
- Removal of the air box or air box cover.
- Modifications to the muffler(s) or air intake system by cutting, drilling, or other means if such modifications result in increased noise levels.

Foreword

This manual is designed primarily for use by trained mechanics in a properly equipped shop. However, it contains enough detail and basic information to make it useful to the owner who desires to perform his own basic maintenance and repair work. A basic knowledge of mechanics, the proper use of tools, and workshop procedures must be understood in order to carry out maintenance and repair satisfactorily. Whenever the owner has insufficient experience or doubts his ability to do the work, all adjustments, maintenance, and repair should be carried out only by qualified mechanics.

In order to perform the work efficiently and to avoid costly mistakes, read the text, thoroughly familiarize yourself with the procedures before starting work, and then do the work carefully in a clean area. Whenever special tools or equipment are specified, do not use makeshift tools or equipment. Precision measurements can only be made if the proper instruments are used, and the use of substitute tools may adversely affect safe operation.

For the duration of the warranty period, we recommend that all repairs and scheduled maintenance be performed in accordance with this service manual. Any owner maintenance or repair procedure not performed in accordance with this manual may void the warranty.

To get the longest life out of your vehicle:

- Follow the Periodic Maintenance Chart in the Service Manual.
- Be alert for problems and non-scheduled maintenance.
- Use proper tools and genuine Kawasaki Motorcycle parts. Special tools, gauges, and testers that are necessary when servicing Kawasaki motorcycles are introduced by the Service Manual. Genuine parts provided as spare parts are listed in the Parts Catalog.
- Follow the procedures in this manual carefully. Don't take shortcuts.
- Remember to keep complete records of maintenance and repair with dates and any new parts installed.

How to Use This Manual

In this manual, the product is divided into its major systems and these systems make up the manual's chapters.

The Quick Reference Guide shows you all of the product's system and assists in locating their chapters. Each chapter in turn has its own comprehensive Table of Contents.

For example, if you want ignition coil information, use the Quick Reference Guide to locate the Electrical System chapter. Then, use the Table of Contents on the first page of the chapter to find the ignition coil section.

Whenever you see these WARNING and CAUTION symbols, heed their instructions! Always follow safe operating and maintenance practices.

WARNING

This warning symbol identifies special instructions or procedures which, if not correctly followed, could result in personal injury, or loss of life.

CAUTION

This caution symbol identifies special instructions or procedures which, if not strictly observed, could result in damage to or destruction of equipment.

This manual contains four more symbols (in addition to WARNING and CAUTION) which will help you distinguish different types of information.

NOTE

○ *This note symbol indicates points of particular interest for more efficient and convenient operation.*

- Indicates a procedural step or work to be done.
- Indicates a procedural sub-step or how to do the work of the procedural step it follows. It also precedes the text of a NOTE.
- ★ Indicates a conditional step or what action to take based on the results of the test or inspection in the procedural step or sub-step it follows.

In most chapters an exploded view illustration of the system components follows the Table of Contents. In these illustrations you will find the instructions indicating which parts require specified tightening torque, oil, grease or a locking agent during assembly.

General Information

Table of Contents

Before Servicing	1-2
Model Identification.....	1-5
General Specifications.....	1-6
Periodic Maintenance Chart (United States and Canada Models).....	1-9
Periodic Maintenance Chart (Other than United States and Canada Models).....	1-11
Technical Information-KLEEN (KAWASAKI LOW EXHAUST EMISSION).....	1-13
Technical Information - Non-Contact Hall IC-Type Speed Sensor.....	1-22
Technical Information - Alternator Made from Rare Magnet.....	1-24
Torque and Locking Agent.....	1-25
Special Tools and Sealant	1-31
Cable, Wire, and Hose Routing.....	1-37
Cable, Wire and Hose Routing (ZX600-J4).....	1-47

1-2 GENERAL INFORMATION

Before Servicing

Before starting to perform an inspection service or carry out a disassembly and reassembly operation on a motorcycle, read the precautions given below. To facilitate actual operations, notes, illustrations, photographs, cautions, and detailed descriptions have been included in each chapter wherever necessary. This section explains the items that require particular attention during the removal and reinstallation or disassembly and reassembly of general parts.

Especially note the following:

(1) Dirt

Before removal and disassembly, clean the motorcycle. Any dirt entering the engine will shorten the life of the motorcycle. For the same reason, before installing a new part, clean off any dust or metal filings.

(2) Battery Ground

Disconnect the ground (–) cable from the battery before performing any disassembly operations on the motorcycle. This prevents the engine from accidentally turning over while work is being carried out, sparks from being generated while disconnecting the leads from electrical parts, as well as damage to the electrical parts themselves. For reinstallation, first connect the positive cable to the positive (+) terminal of the battery

(3) Installation, Assembly

Generally, installation or assembly is the reverse of removal or disassembly. However, if installation or assembly sequence is given in this Service Manual, follow it. Note parts locations and cable, wire, and hose routing during removal or disassembly so they can be installed or assembled in the same way. It is preferable to mark and record the locations and routing whenever possible.

(4) Tightening Sequence

When installing bolts, nuts, or screws for which a tightening sequence is given in this Service Manual, make sure to follow the sequence. When installing a part with several bolts, nuts, or screws, start them all in their holes and tighten them to a snug fit, thus ensuring that the part has been installed in its proper location. Then, tighten them to the specified torque in the tightening sequence and method indicated. If tightening sequence instructions are not given, tighten them evenly in a cross pattern. Conversely, to remove a part, first loosen all the bolts, nuts, or screws that are retaining the part a 1/4-turn before removing them.

(5) Torque

When torque values are given in this Service Manual, use them. Either too little or too much torque may lead to serious damage. Use a good quality, reliable torque wrench.

(6) Force

Common sense should dictate how much force is necessary in assembly and disassembly. If a part seems especially difficult to remove or install, stop and examine what may be causing the problem. Whenever tapping is necessary, tap lightly using a wooden or plastic-faced mallet. Use an impact driver for screws (particularly for the removing screws held by non-permanent locking agent) in order to avoid damaging the screw heads.

(7) Edges

Watch for sharp edges, as they could cause injury through careless handling, especially during major engine disassembly and assembly. Use a clean piece of thick cloth when lifting the engine or turning it over.

(8) High-Flash Point Solvent

A high-flash point solvent is recommended to reduce fire danger. A commercial solvent commonly available in North America is standard solvent (generic name). Always follow manufacturer and container directions regarding the use of any solvent.

(9) Gasket, O-Ring

Replace a gasket or an O-ring with a new part when disassembling. Remove any foreign matter from the mating surface of the gasket or O-ring to ensure a perfectly smooth surface to prevent oil or compression leaks.

(10) Liquid Gasket, Locking Agent

Clean and prepare surfaces where liquid gasket or non-permanent locking agent will be used. Apply them sparingly. Excessive amount may block engine oil passages and cause serious damage.

Before Servicing

(11) Press

When using a press or driver to install a part such as a wheel bearing, apply a small amount of oil to the area where the two parts come in contact to ensure a smooth fit.

(12) Ball Bearing and Needle Bearing

Do not remove a ball bearing or a needle bearing unless it is absolutely necessary. Replace any ball or needle bearings that were removed with new ones. Install bearings with the manufacturer and size marks facing out, applying pressure evenly with a suitable driver. Apply force only to the end of the race that contacts the press fit portion, and press it evenly over the base component.

(13) Oil Seal and Grease Seal

Replace any oil or grease seals that were removed with new ones, as removal generally damages seals. Oil or grease seals should be pressed into place using a suitable driver, applying a force uniformly to the end of seal until the face of the seal is even with the end of the hole, unless instructed otherwise. When pressing in an oil or grease seal which has manufacturer's marks, press it in with the marks facing out.

(14) Circlip, Retaining Ring, and Cotter Pin

When installing circlips and retaining rings, take care to compress or expand them only enough to install them and no more. Install the circlip with its chamfered side facing load side as well.

Replace any circlips, retaining rings, and cotter pins that were removed with new ones, as removal weakens and deforms them. If old ones are reused, they could become detached while the motorcycle is driven, leading to a major problem.

(15) Lubrication

Engine wear is generally at its maximum while the engine is warming up and before all the sliding surfaces have an adequate lubricative film. During assembly, make sure to apply oil to any sliding surface or bearing that has been cleaned. Old grease or dirty oil could have lost its lubricative quality and may contain foreign particles that act as abrasives; therefore, make sure to wipe it off and apply fresh grease or oil. Some oils and greases in particular should be used only in certain applications and may be harmful if used in an application for which they are not intended.

(16) Direction of Engine Rotation

To rotate the crankshaft manually, make sure to do so in the direction of positive rotation. Positive rotation is counterclockwise as viewed from the left side of the engine. To carry out proper adjustment, it is furthermore necessary to rotate the engine in the direction of positive rotation as well.

(17) Replacement Parts



When there is a replacement instruction, replace these parts with new ones every time they are removed.

Replacement parts will be damaged or lose their original function once they are removed. Therefore, always replace these parts with new ones every time they are removed. Although the previously mentioned gasket, O-ring, ball bearing, needle bearing, grease seal, oil seal, circlip, and cotter pin have not been so designated in their respective text, they are replacement parts.

(18) Electrical Leads

All the electrical leads are either one-color or two-color. A two-color lead is identified first by the primary color and then the stripe color. For example, a yellow lead with thin red stripes is referred to as a "yellow/red" lead; it would be a "red/yellow" lead if the colors were reversed. Unless instructed otherwise, electrical leads must be connected to leads of the same color.

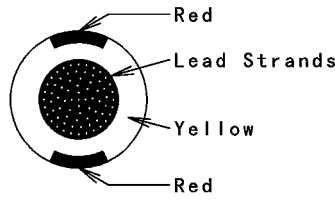
Two-Color Electrical

Lead (cross-section)	Color Indicated on the Lead	Color Indicated on the Wiring Diagram
	<p style="text-align: center;">Yellow/Red</p>	

1-4 GENERAL INFORMATION

Before Servicing

(19) Inspection

When parts have been disassembled, visually inspect these parts for the following conditions or other damage. If there is any doubt as to the condition of them, replace them with new ones.

Abrasion	Crack	Hardening	Warp
Bent	Dent	Scratch	Wear
Color change	Deterioration	Seizure	

(20) Specifications

Specification terms are defined as follows:

“Standards” show dimensions or performances which brand-new parts or systems have.

“Service Limits” indicate the usable limits. If the measurement shows excessive wear or deteriorated performance, replace the damaged parts.

Model Identification

ZX600-J1 Left Side View



ZX600-J1 Right Side View



1-6 GENERAL INFORMATION

General Specifications

Items	ZX600-J1, J2	ZX600-J3 ~
Dimensions		
Overall Length	2 030 mm (79.9 in.), (PN) 2 060 mm (81.1 in.)	←
Overall Width	730 mm (28.7 in.)	←
Overall Height	1 175 mm (46.3 in.)	←
Wheelbase	1 400 mm (55.1 in.)	←
Road Clearance	145 mm (5.70 in.)	←
Seat Height	820 mm (32.3 in.)	←
Dry Mass	171 kg (377 lb), (CAL) 173 kg (382 lb), (H) 172 kg (379 lb)	←
Curb Mass:		
Front	100 kg (221 lb)	←
Rear	96 kg (212 lb), (CAL) 98 kg (216 lb), (H) 97 kg (214 lb)	←
Fuel Tank Capacity	18 L (4.76 US gal)	←
Performance		
Minimum Turning Radius	3.2 m (10.5 ft)	←
Engine		
Type	4-stroke, DOHC, 4-cylinder	←
Cooling System	Liquid-cooled	←
Bore And Stroke	66 × 43.8 mm (2.60 × 1.72 in.)	←
Displacement	599 cm ³ (36.6 cu in.)	←
Compression Ratio	12.8	←
Maximum Horsepower	81.6 kW (111 PS) @12 500 r/min (rpm), (AU) 80.6 kW (109.6 PS) @12 500 r/min (rpm), (PR) 78.2 kW (106.3 PS) @12 500 r/min (rpm), (US) — — —	←
Maximum Torque	65.6 N·m (6.7 kgf·m, 48 ft·lb) @10 000 r/min (rpm), (AU) 64.6 N·m (6.6 kgf·m, 48 ft·lb) @10 000 r/min (rpm) (US) — — —	←
Carburetion System	Carburetors, Mikuni BDSR 36R × 4	←
Starting System	Electric starter	←
Ignition System	Battery and coil (transistorized)	←
Timing Advance	Electronically advanced(digital igniter)	←
Ignition Timing	From 12.5° BTDC @1 300 r/min (rpm) to 42.5° BTDC @5 000 r/min (rpm)	←
Spark Plug	NGK CR9E	←
Cylinder Numbering Method	Left to right, 1-2-3-4	←
Firing Order	1-2-4-3	←
Valve Timing:		
Inlet:		
Open	56° BTDC	←
Close	80° ABDC	←
Duration	316°	←

General Specifications

Items	ZX600-J1, J2	ZX600-J3 ~
Exhaust: Open Close Duration Lubrication System Engine Oil: Grade Viscosity Capacity	61° BBDC 33° ATDC 274° Forced lubrication (wet sump with cooler) API SE, SF or SG API SH, SJ with JASO MA (ZX600J1 ~ J4, J6F) API SH, SJ or SL with JASO MA (ZX600J7F ~) SAE10W-40, 10W-50, 20W-40, or 20W-50 4.0 L (4.23 US qt)	← ← ← ← ← ← ← ←
Drive Train Primary Reduction System: Type Reduction Ratio Clutch Type Transmission: Type Gear Ratios: 1st 2nd 3rd 4th 5th 6th Final Drive System: Type Reduction Ratio Overall Drive Ratio	Gear 2.022 (89/44) Wet multi disc 6-speed, constant mesh, return shift 2.923 (38/13) 2.062 (33/16) 1.631 (31/19) 1.380 (29/21) 1.217 (28/23) 1.083 (26/24) Chain drive 2.666 (40/15) 5.843 @Top gear	← ← ← ← ← ← ← ← ← ← ← ←
Frame Type Caster (Rake Angle) Trail Front Wheel: Tire Type Tire Size Rim Size Rear Wheel: Tire Type Tire Size Rim Size	Tubular, diamond 23.5° 95 mm (3.7 in.) Tubeless 120/65 ZR17 (56 W) J 17M/C × MT3.50 Tubeless 180/55 ZR17 (73 W) J 17M/C × MT5.50	← ← ← ← 120/65 ZR17 M/C (56 W) ← ← 180/55 ZR17 M/C (73 W) ←

1-8 GENERAL INFORMATION

General Specifications

Items	ZX600-J1, J2	ZX600-J3 ~
Front Suspension:		
Type	Telescopic fork	←
Wheel Travel	120 mm (4.7 in.)	←
Rear Suspension:		
Type	Swingarm (uni-trak)	←
Wheel Travel	135 mm (5.3 in.)	←
Brake Type:		
Front	Dual discs	←
Rear	Single disc	←
Electrical Equipment		
Battery	12 V 8 Ah	←
Headlight:		
Type	Semi-sealed beam	←
Bulb	12 V 60/55 W (quartz-halogen) × 2	←
Tail/Brake Light	12 V 5/21 W × 2	←
Alternator:		
Type	Three-phase AC	←
Rated Output	22 A/14 V @5 000 r/min (rpm)	←

Specifications are subject to change without notice, and may not apply to every country.

H: WVTA Approval Model with Honeycomb Catalytic Converter

PN: WVTA Approval Model with Pipe Catalytic Converter (Norway Model)

PR: WVTA Approval Model with Pipe Catalytic Converter (Restricted Power Model)

AU: Australia

CAL: California

US: United States

GENERAL INFORMATION 1-9

Periodic Maintenance Chart (United States and Canada Models)

The scheduled maintenance must be done in accordance with this chart to keep the motorcycle in good running condition. **The initial maintenance is vitally important and must not be neglected.**

OPERATION	FREQUENCY	Whichever comes first ↓ Every	* ODOMETER READING × 1 000 km (× 1 000 mile)						Re- marks	
			1 (0.6)	6 (4)	12 (7.5)	18 (12)	24 (15)	30 (20)		36 (24)
Spark plug - clean and gap †				•	•	•	•	•	•	
Valve clearance - Inspect †					•		•		•	
Air suction valve - Inspect †				•	•	•	•	•	•	
Air cleaner element and air vent filter - clean †#					•		•		•	
Throttle grip play - Inspect †			•		•		•		•	
Idle speed - Inspect †			•		•		•		•	
Carburetor synchronization - Inspect †					•		•		•	
Fuel hoses, Connections - Inspect †				•	•	•	•	•	•	
Engine oil - change #		6 months	•	•	•	•	•	•	•	
Oil filter - replace			•		•		•		•	
Evaporative emission control system (CAL) - Inspect †			•	•	•	•	•	•	•	
Drive chain wear - Inspect †#				•	•	•	•	•	•	
Brake pad wear - Inspect †#				•	•	•	•	•	•	
Brake light switch - Inspect †			•	•	•	•	•	•	•	
Steering - Inspect †			•	•	•	•	•	•	•	
Rear shock absorber oil leak - Inspect †					•		•		•	
Front fork oil leak - Inspect †					•		•		•	
Tire wear - Inspect †				•	•	•	•	•	•	
Swingarm pivot, Unit-trak linkage - lubricate					•		•		•	
General lubrication - perform					•		•		•	
Nut, bolts, and fasteners tightness - Inspect †			•		•		•		•	
Drive chain - lubricate #		600 km		•	•	•	•	•	•	
Drive chain slack - Inspect †#		1000 km	•	•	•	•	•	•	•	
Brake hoses, connections - Inspect †				•	•	•	•	•	•	
Brake fluid level - Inspect †		month	•	•	•	•	•	•	•	
Clutch adjust - Inspect †		month	•	•	•	•	•	•	•	
Radiator hoses, connections - Inspect †			•							
Brake fluid - change		2 years					•			
Brake master cylinder cup and dust cover - replace		4 years								
Coolant - change		2 years					•			
Caliper fluid seal and dust seal - replace		4 years								
Steering stem bearing - lubricate		2 years					•			

1-10 GENERAL INFORMATION

Periodic Maintenance Chart (United States and Canada Models)

OPERATION	FREQUENCY	Whichever comes first ↓ Every	* ODOMETER READING × 1 000 km (× 1 000 mile)							Re- marks
			1 (0.6)	6 (4)	12 (7.5)	18 (12)	24 (15)	30 (20)	36 (24)	
Coolant filter - clean		year								

#: Service more frequently when operating in severe conditions; dusty, wet, muddy, high speed, or frequent starting/stopping.

*: For higher odometer readings, repeat at the frequency interval established here.

†: Replace, add, adjust, clean, or torque if necessary.

CAL: California

1-12 GENERAL INFORMATION

Periodic Maintenance Chart (Other than United States and Canada Models)

#: Service more frequently when operating in severe conditions; dusty, wet, muddy, high speed, or frequent starting/stopping.

*: For higher odometer readings, repeat at the frequency interval established here.

†: Replace, add, adjust, clean, or torque if necessary.

Technical Information-KLEEN (KAWASAKI LOW EXHAUST EMISSION)

The ZX600J have catalytic converters.

The secondary air injection system [A] helps Kawasaki keep motorcycle exhaust gases below the established emission regulation limits. This system draws air into the exhaust ports, dilutes and burns harmful ingredients in the exhaust gas in order to reduce them. This allows the carburetor to be set at a reasonable setting position without adjusting it much leaner, so engine performance and actual riding performance are not spoiled.

But, under the trend that the emission regulation becomes more severe, Kawasaki has adopted two catalytic converters [B] in addition to the secondary air injection system. Moreover, a BDSR 36-type carburetor has been adopted because of its good balance between cost and performance. As a result, we can reduce the exhaust gas emission below the current standards without hurting the output performance and the actual riding feeling at all. The harmful ingredients in the exhaust gas are reduced considerably under running performance of emission regulation like LA4 or EC mode. As actual examples, carbon monoxide (CO) is reduced about 70%, hydrocarbons (HC) about 60%, nitrogen oxides (NOx) about 10%.

Moreover, in order to improve the reliability of the system, we install fuel cut valves [C] as a catalyst protection system.

Exhaust Gas after Purification

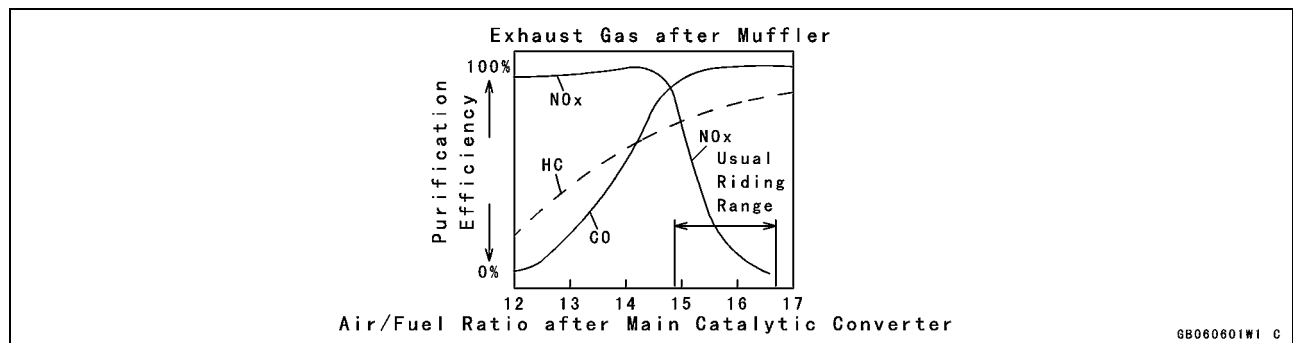

Kawasaki Low Exhaust Emission System

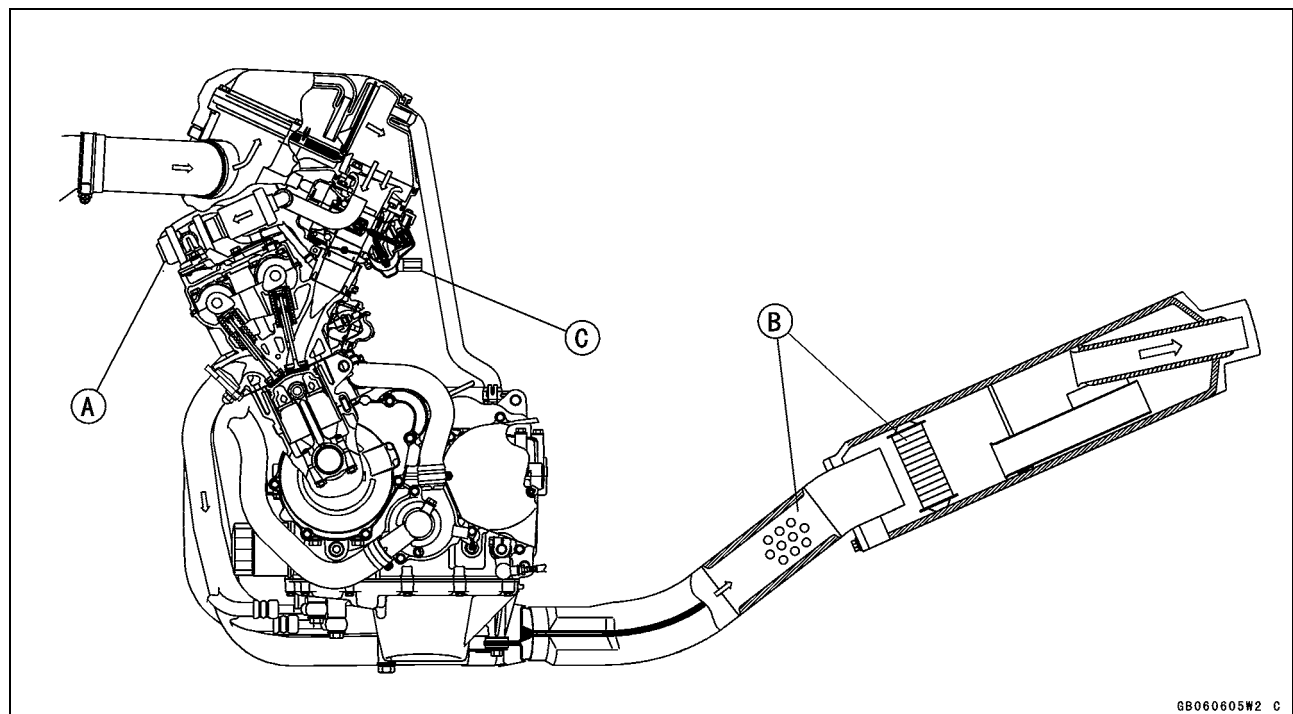

1-14 GENERAL INFORMATION

Technical Information-KLEEN (KAWASAKI LOW EXHAUST EMISSION)

1. Exhaust Purification System

The burned gas, which goes out from the combustion chamber, is injected with secondary air (adding necessary oxygen), and is cleaned up while passing through the small pre-catalytic converters in the joint pipe and the main catalytic converter in the silencer, and then goes out to the atmosphere.

Secondary Air Injection System

1) In order to oxidize CO, and HC by the catalysts, the proper amount of oxygen is necessary. As original combustion gas has little remaining oxygen, air is injected in the exhaust ports by the secondary air injection system in order to supply enough oxygen to the combustion gas to purify CO, and HC to a certain extent as well as prepare for activation of the catalysts. Since the carburetor is set at richer level [A], and air/fuel mixture (A/F) is about 11 ~ 14, NOx is at lower level from the beginning as shown in the figure. And, A/F becomes lean (about 13.5 ~ 15) after the combustion chambers owing to secondary air injection and combustion.

Exhaust Gas before Purification

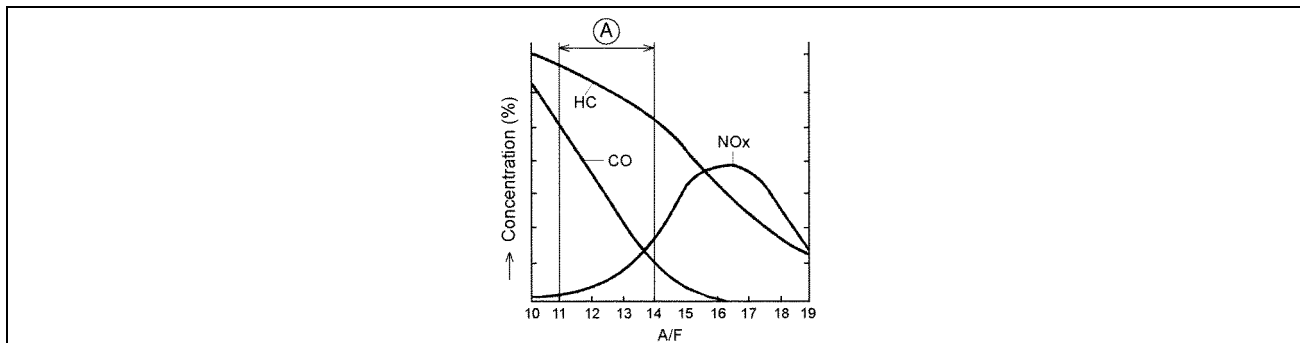

2) Precatalytic Converters [A]

A small-size three-way catalytic converter (pre-catalytic converter) is installed in the pipe ahead at the joint [B] of the silencer. A pre-catalytic converter is made of a punched metal pipe [C] of stainless steel, and its surface is covered with alumina upon which platinum and rhodium as catalysts are applied. Generally, the temperature of the exhaust gas must be higher than the activation temperature, so we set this pre-catalytic converter at the upper portion of the main catalytic converter where the temperature of exhaust gas is high. Accordingly, the pre-catalytic converter will be activated even under low load conditions. Activation of the pre-catalytic converter raises the exhaust gas temperature by the catalyst reaction, which helps the main catalytic converter operate more efficiently. The pre-catalytic converter purifies CO, HC, and NOx to a certain extent.

3) Main Catalytic Converters [D]

The converter is a three-way catalytic converter upon which platinum and rhodium are applied, and has a cylindrical metallic honeycomb structure [E] made by bending a corrugated sheet and a flat sheet of stainless steel into a spiral of increasing diameter. The main catalytic converter is installed in the first expansion chamber of the silencer. When the exhaust gas passes through the upper portion of the secondary air injection system, the pre-catalytic converter, and the inside of the honeycomb, the main catalytic converter works efficiently to reduce CO, HC, and NOx. So, we can keep it within regulation.

The honeycomb structure is convenient for the catalytic converter because it has a large surface area but small size to react effectively and has low exhaust resistance. In addition, its inherent strength helps resist vibration, and has simple structure welded directly on the silencer.

Technical Information-KLEEN (KAWASAKI LOW EXHAUST EMISSION)

Catalytic Converters

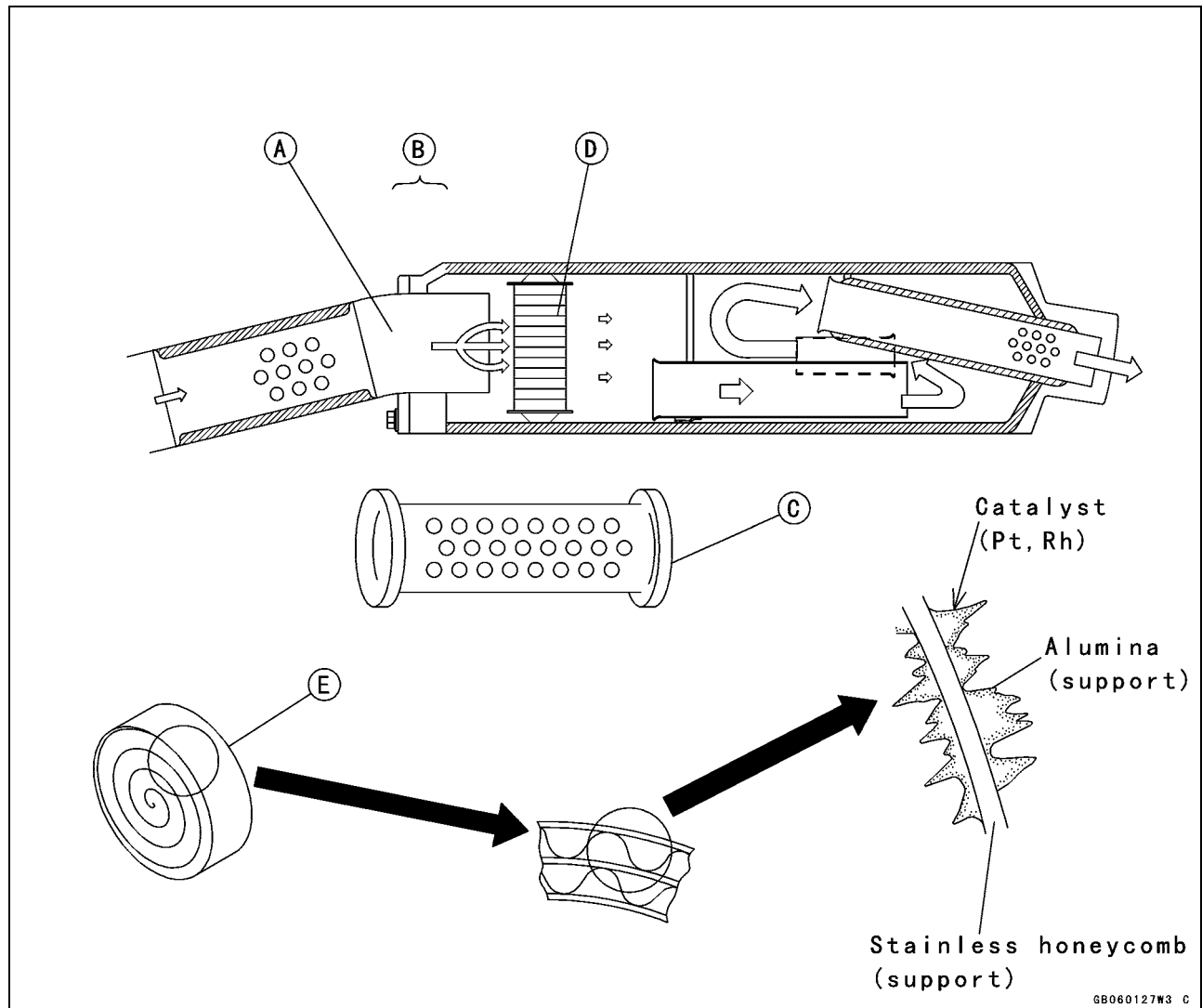

2. Catalyst Protection System

When excessive unburned gasoline flows more than the allowable amount into the exhaust gas during running, the temperature of the catalysts rises abnormally because the unburned gasoline reacts with heated catalysts (at the activation temperature or higher). In an excessive case, the problem such as melting-down occurs. Moreover, there is a possibility that the purification performance becomes poorer when it is cool (below the activation temperature). So, the fuel cut valve [A] as a catalyst protection system is installed on each carburetor float bowl [B]. It runs by the IC Igniter and opens and closes the fuel passage toward a main jet [C]. A catalyst protection system works in the following cases.

- 1) Prevention of unburned gasoline from flowing when overspeed limiter works.
The limiter has fuel cut-off and ignition cut-off operations.
- 2) Prevention of unburned gasoline from flowing when the engine stop switch is turned off during running.
When the engine stop switch is turned off while coasting the motorcycle, fuel is cut off. For example, fuel is cut off under the abnormal running condition that you go down the slope with the engine stop switch OFF.
- 3) Prevention of unburned gasoline from flowing when misfire occurs by a cutoff of a primary coil in a stick coil.
Fuel is cut off when an electric current of a primary coil becomes abnormal because of a cutoff of the primary coil when the engine is running.
- 4) Prevention of solenoid valve lock
If a driver always runs the engine under the red zone in the tachometer, the IC igniter doesn't operate overspeed limiter and the catalyst protection system doesn't have a chance to work. The

1-16 GENERAL INFORMATION

Technical Information-KLEEN (KAWASAKI LOW EXHAUST EMISSION)

old fuel may gum up the fuel cut valves which remain seated in the float bowls. To cope with, the IC igniter test-operates the fuel cut valves when starting the engine and prevents lock of the valves.

5) Usage of leaded gasoline is prohibited completely.

Leaded gasoline harms the purification efficiency of the catalyts.

The performance of the catalyst protection system is summed up as follows.

Fuel Cut Valve

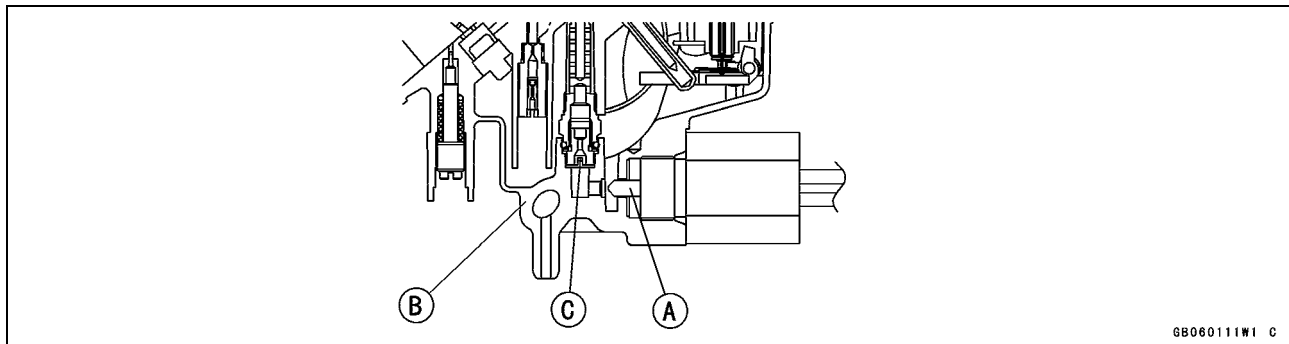

Performance of Catalyst Protection System

No	Running Condition	Ignition Switch	Engine Stop Switch	Protection System	Fuel Cutvalve	Remedy (Action)
1	Normal	ON	ON	OFF	OPEN	<ul style="list-style-type: none"> • Not necessary (Normal condition)
2	Overspeed performance	ON	ON	ON	CLOSE	<ul style="list-style-type: none"> • Not necessary
3	Abnormal (misfire) <ul style="list-style-type: none"> • Defects at the stick coil primary-side 	ON	ON	ON	CLOSE	<ul style="list-style-type: none"> • Inspect the connection at the primary-side of the stick coil.
4	Abnormal (misfire) <ul style="list-style-type: none"> • Defects at the stick coil secondary-side • Battery is dead. • Spark plug fouling • Defects of the pickup coil • Defects of the IC igniter • Defects of the carburetor 	ON	ON	OFF	OPEN	<ul style="list-style-type: none"> • Inspect the stick coil. • Charge the battery. • Clean the spark plug and adjust the gap. • Inspect and replace the pickup coil. • Inspect and replace the IC igniter. • Inspect and adjust the carburetor.
5	Abnormal (no spark) <ul style="list-style-type: none"> • Short of the engine stop switch 	ON	OFF	ON	CLOSE	<ul style="list-style-type: none"> • Inspect and repair the engine stop switch.
	<ul style="list-style-type: none"> • While coasting the motorcycle, do not turn the engine stop switch OFF. 					<ul style="list-style-type: none"> • Turn the engine stop switch ON, and run.

Technical Information-KLEEN (KAWASAKI LOW EXHAUST EMISSION)

No	Running Condition	Ignition Switch	Engine Stop Switch	Protection System	Fuel Cutvalve	Remedy (Action)
6	Abnormal (no spark) <ul style="list-style-type: none"> ● Short of the ignition switch ● While coasting the motorcycle, do not turn the ignition switch OFF. 	OFF	ON or OFF	OFF	OPEN	<ul style="list-style-type: none"> ● Inspect and replace the ignition switch. ● Turn the ignition switch and the engine stop switch ON, and run.

3. Maintenance

Special maintenance is not necessary except for the inspection of the air suction valve (which has been described in this manual).

1) Replacement of Muffler Assy

It is impossible to replace only catalytic converters because they are welded in the muffler. So, in the following case, the replacement of the muffler assy is also necessary.

- In case of using not-appointed fuel (leaded gasoline, etc.):
Purification efficiency decreases in a very short period because lead poisons the catalytic converters. Although the appearance of the converter and engine performance are not effected, the replacement of a muffler assy is necessary to secure the purification efficiency of exhaust gas.
- In case catalytic converters melt down by overheating:
Especially in the case that a lot of unburned gasoline flows into the catalytic converters under the extreme running condition far beyond common sense, there is a possibility that the catalysts overreact and that catalytic converters overheat severely. If they melt down, it causes poor engine performance, deterioration of emission noise level, and purification efficiency. So, the muffler assy must be replaced

2) Durability

It has the same durability as a conventional muffler.

3) Disposal to Waste

As any harmful toxic substance is not used especially, it can be disposed as usual industrial wastes. The body of the muffler is made of aluminum steel. The catalytic converter is also made of stainless steel which has alumina on its surface, and the main ingredients of catalysts are platinum and rhodium.

4. Handling Precautions

Catalyst protection system against mishandling is applied to a vehicle with catalysts. But, we prohibit depending on the system too much when running.

1) Use only unleaded gasoline:

Usage of leaded gasoline is prohibited completely. Only fuel and additives which are specified in the Owner's Manual can be used.

2) Use specified engine oil which is described in the Owner's Manual:

In case of some ingredients which give bad effects to the catalysts (such as phosphorus "P", lead "Pb", sulfur "S") are included, the purification efficiency decreases.

3) Coasting (such as cranking while going down a slope) is prohibited with the ignition system OFF:

The engine running without igniting causes a great flow of unburned gasoline and the decreasing of purification efficiency, and melting down of catalysts at the activation temperature or higher.

1-18 GENERAL INFORMATION

Technical Information-KLEEN (KAWASAKI LOW EXHAUST EMISSION)

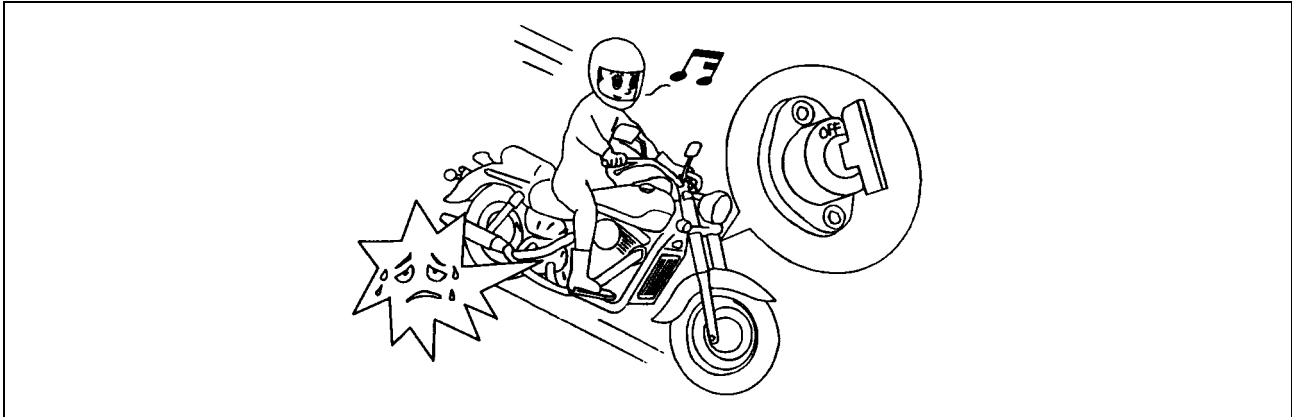

- When the ignition switch [A] is turned off, the fuel cut valves [B] do not work. So, avoid coasting with the ignition switch OFF.
- Do not run the engine nor coast the motorcycle under the misfire which occurs by defects such as a bad connection with the spark plug at the secondary wiring of the stick coil [C].
- Do not coast too much with the engine stop switch [D] OFF. Under the condition that the engine stop switch is turned off during running, the IC igniter [E] closes the fuel cut valves to shut off fuel.
- Do not run the engine nor coast the motorcycle too much under the condition that the primary wiring of the stick coil does not connect completely (misfire). Incomplete connection or cut-off of the primary coil makes the fuel cut valves start to cut fuel. In this case, from the standpoint to protect the catalyts, the fuel for all cylinders is cut off even if one cylinder has been affected.

Kawasaki Low Exhaust Emission System

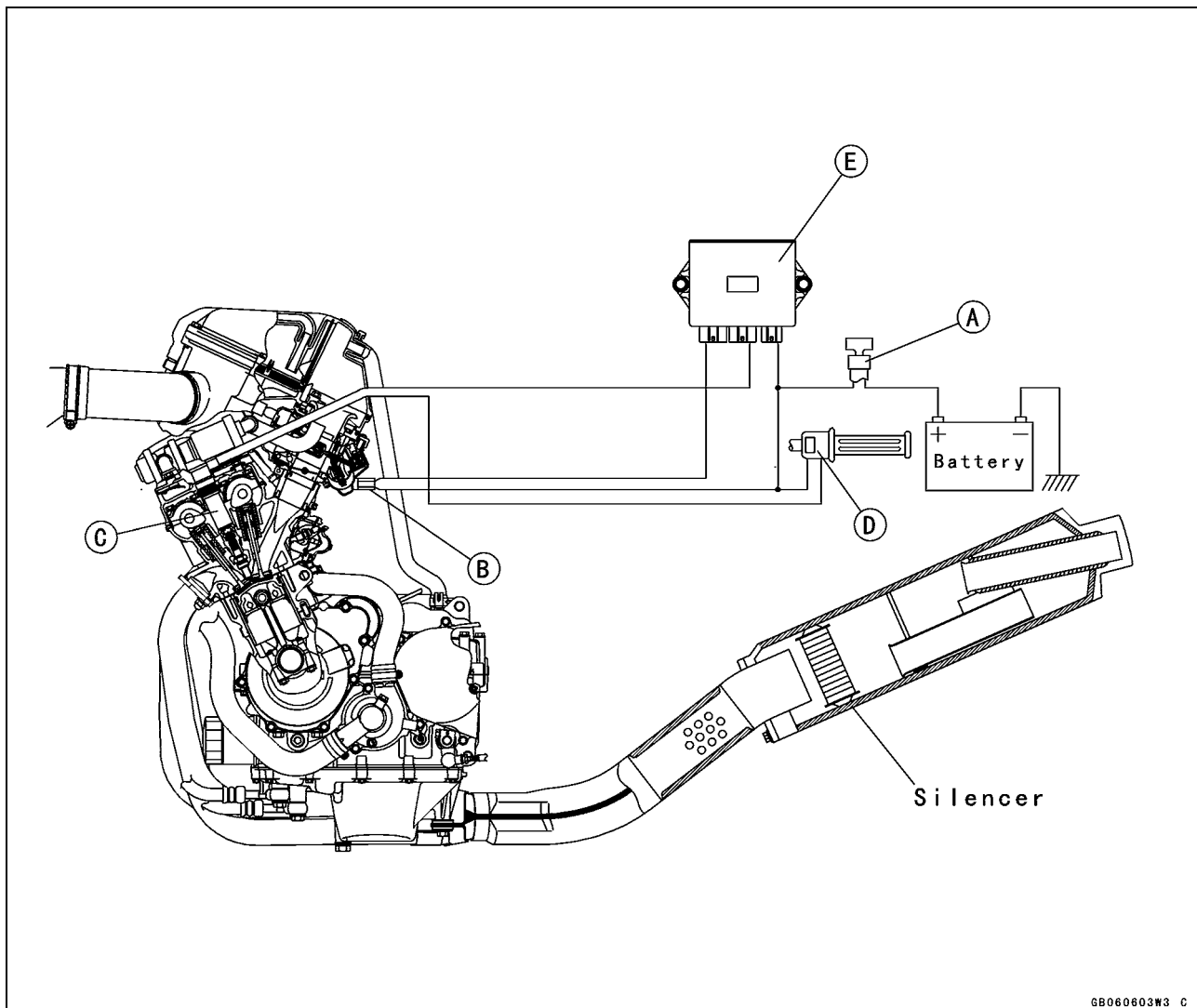

Technical Information-KLEEN (KAWASAKI LOW EXHAUST EMISSION)

- Do not run overspeed limiter too much from the standpoint to protect the engine. (Overspeed limiter has a protection system that applies ignition cut method and fuel cut method together. Conventional system applies fuel-on method.)
- Do not run the engine even if only one cylinder has a misfire or has unstable running. In this case, request the nearest service facility to correct it. If you have no choice but running by yourself, keep engine rpm as low as possible and try to finish running at the shortest period.
- When the battery is dead, do not push-start. Connect another full-charged battery with jumper cables, and start the engine.

5. Additional Information**1) Secondary Air Injection System**

The mechanism is simple and power loss is minimum because the system uses the vacuum pressure created by exhaust pulses.

The secondary injection air helps the fuel/air mixture burn more completely (Primary air means air which flows through the inlet pipe). As the exhaust valve opens, and the burned fuel passes the exhaust valve, a stream of fresh air is introduced through the air suction valve. This fresh air burns the unburned gas and converts the carbon monoxide (CO) and hydrocarbons (HC) into harmless carbon dioxide (CO₂) and water (H₂O).

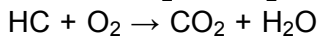
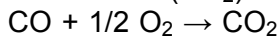

The secondary air injection system consists of a vacuum switch valve, and two air suction valves. Without using an air pump, the air suction valve can draw fresh air into the exhaust passage near the exhaust valves by vacuum that exhaust pulses generate.

Air Suction Valves

The air suction valves is a check valve which allows fresh air to flow only from the air cleaner via air hoses into the exhaust port and prevents return flow. Remove and inspect the air suction valves periodically (see Engine Top End chapter in this Service Manual). Also, remove and inspect the air suction valves whenever the idle speed is unstable, engine power is greatly reduced, or there are abnormal engine noises.

Vacuum Switch Valve

Although the vacuum switch valve usually permits secondary air flow, it closes when a high vacuum (low pressure) is developed at the inlet pipe during engine braking. This is to shut off secondary air flow and prevent explosions in the exhaust ports which might be caused by extra unburned fuel in the exhaust during deceleration. These explosions, or backfiring in the exhaust system could damage the air suction valves.

Regular inspection of the vacuum switch valve is not needed. If backfiring occurs frequently in the exhaust system during engine braking or if there are abnormal engine noises, check the vacuum switch valve as described in the text (see Engine Top End chapter in this Service Manual).

1-20 GENERAL INFORMATION

Technical Information-KLEEN (KAWASAKI LOW EXHAUST EMISSION)

Secondary Air Injection System

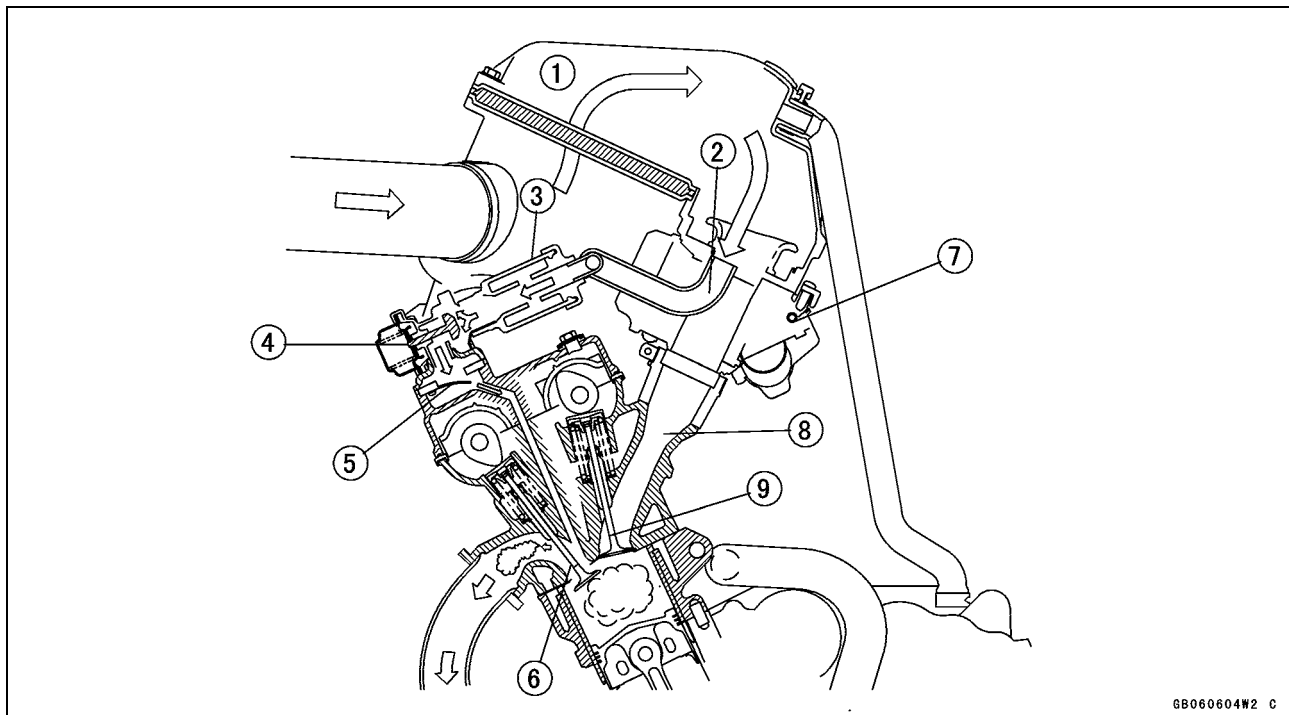

- | | |
|------------------------|------------------|
| 1. Air Cleaner Housing | 6. Exhaust Valve |
| 2. Air Hose | 7. Carburetors |
| 3. Inlet Silencer | 8. Inlet Pipe |
| 4. Vacuum Switch Valve | 9. Inlet Valve |
| 5. Air Suction Valve | |

2) Operation of Three-way Catalytic Converter

The three-way catalysts are used for the catalytic converters and the main catalytic converter. These converters can clean up carbon monoxide (CO), hydrocarbons (HC), and nitrogen oxides (NOx) at the same time.

CO and HC are oxidized (O is added) by platinum (Pt) and converted to harmless carbon dioxide gas (CO₂) and water (H₂O), and then the exhaust gas is cleaned up:

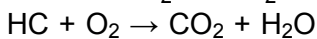
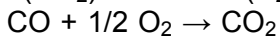

NOx is reduced (O is removed) by rhodium (Rh) and converted to harmless nitrogen (N₂) and oxygen (O₂), and the exhaust gas is cleaned up.

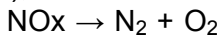

Main Catalytic Converter

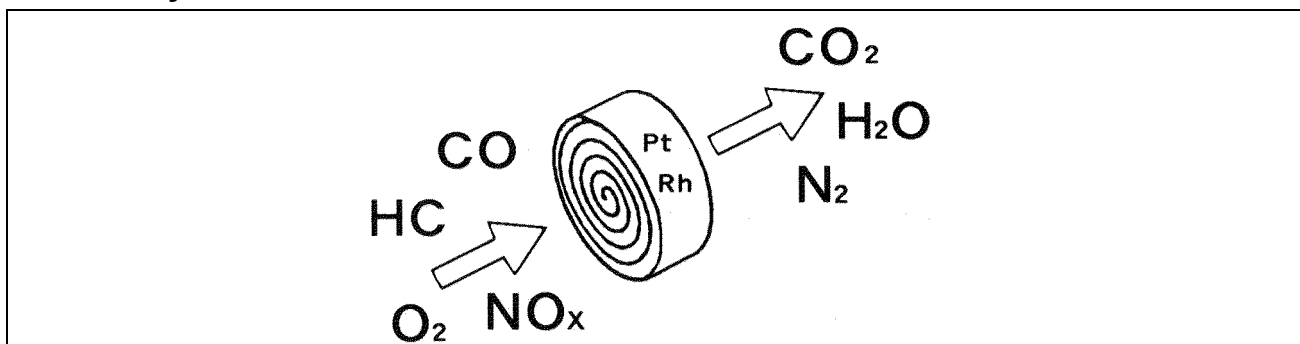

Technical Information-KLEEN (KAWASAKI LOW EXHAUST EMISSION)

3) Property of Catalyst

Most catalysts are powders of metal or of metallic compounds, and they increase the rate of a chemical reaction.

Catalysts are supposed to act in some way to loosen the bonds of the reacting substances. In other words, they lower the energy of activation, thus allowing the reaction to proceed more rapidly. To activate catalysts, the temperature of the exhaust gas must be higher than the activation temperature that is 220° ~ 230°C for new catalysts, and 270° ~ 280 °C for used catalysts (after 10 000 ~ 20 000 km ride).

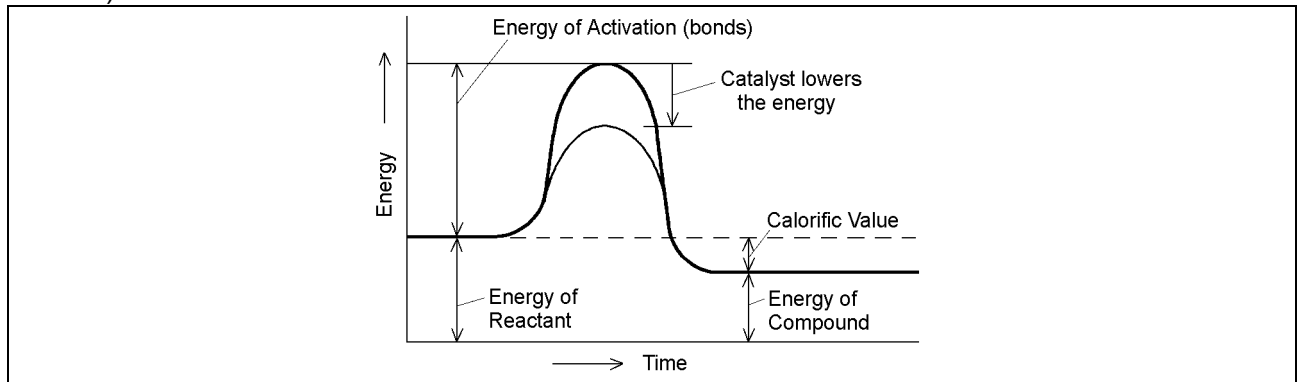

The catalyst itself undergoes no permanent chemical change, or can be recovered when the chemical reaction is completed. So, the muffler with built-in catalyst has the same durability as the conventional muffler.

The mechanism of catalytic action is supposed to be a surface phenomenon in which reactants are absorbed onto a small portion of the surface of the catalyst. The catalytic converter is made of stainless steel and the surface is applied by alumina (aluminum oxide Al_2O_3). The alumina adheres to the stainless steel wall and the catalyst adheres to the alumina very well. The alumina surface is not uniform and there are corners, edges, dislocations, and grain boundaries. Catalyst is applied on the alumina and this makes the catalyst surface rough. The rougher the surface is, the more actively the catalyst absorbs the reactants.

If various impurities like lead are absorbed, they block the small portion of the catalyst surface, preventing absorption of CO, HC, and NOx. This is the reason why leaded fuel poisons the catalyst without any break on the surface or generation of heat.

Catalysts are generally efficient in small quantities. A catalyst can catalyze the reaction of several thousand to a million times its weight in reactants. The three-way catalyst is a blend of platinum (Pt) and rhodium (Rh) which are expensive. But a converter uses only about 0.05 gram of Pt and 0.01 gram of Rh and a main catalytic converter uses only about 0.4 gram of Pt and 0.1 gram of Rh.

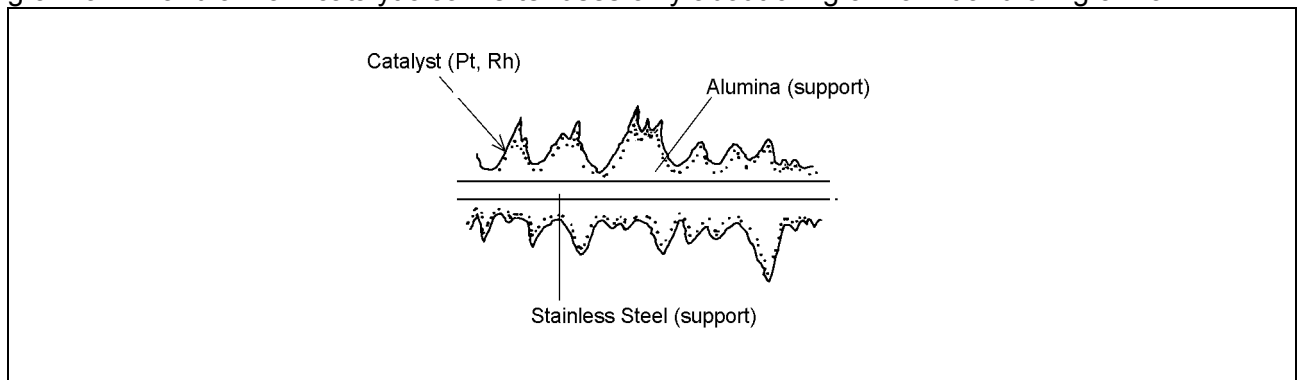

1-22 GENERAL INFORMATION

Technical Information - Non-Contact Hall IC-Type Speed Sensor

Details

The electronic combination meter unit, superior to the conventional type in weight and durability is installed on the ZX600-J. The hall IC-type speed sensor is installed on the ZX600-J together with it, which needs no cable and speedometer gears. Its construction and operation are described as follows;

Construction and Operation

- The speed sensor [A] consists of a magnet [B] and the Hall IC [C].

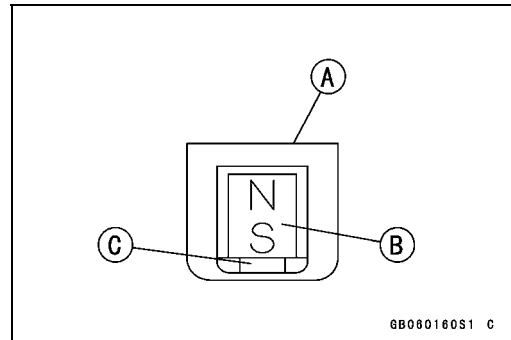

- The Hall IC consists of Hall element [A], the differential amplifier [B], the high pass filter [C], the comparator [D] and the output transistor [E].

Hall Element

The semi-conductors (e.g. CaAs, InAs, InSb) are called as mentioned above. The magnetic induction applied on the two (2) Hall elements will be converted into the voltage, and outputted.

Differential Amplifier

This can output the difference between output powers of the two (2) Hall elements.

High Pass Filter

Sensitivity of the two (2) Hall elements.

Surface magnetic induction of a magnet.

Relative positions of the Hall element, magnet, and detector gear.

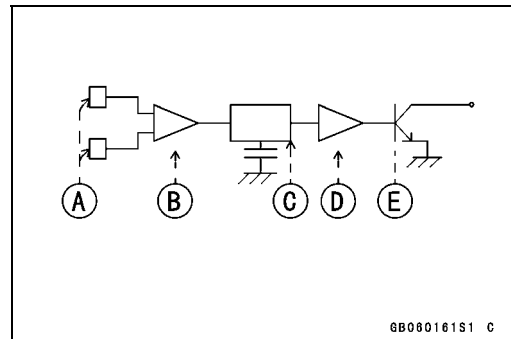

Able to cancel the DC off-set because of scattering of differential output.

Comparator & Output Transistor

Able to output the square wave in accordance with the magnetic induction alternation with the transistor turning on or off.

- The magnetic induction passing through the Hall element will be changed in accordance with the relative position of the sensor and the rotor nut [A] installed on the engine sprocket will be rotated.

amount of magnetic induction

when large [B]

when small [C]

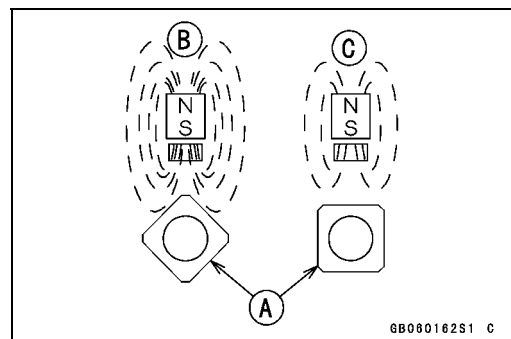

Technical Information - Non-Contact Hall IC-Type Speed Sensor

- In the internal system of the Hall IC, the switch is operated in accordance with the magnetic induction alternator. This makes the square wave equal to the pulse of the rotor nut output.

Amount of magnetic induction when large [A]

Amount of magnetic induction when small [B]

Operating point [C]

Returning point [D]

When high voltage [E]

When low voltage [F]

- The vehicle speed is indicated in the speedometer, altering the pulse of this square wave.

Speed Sensor Inspection

- Refer to the Electrical System chapter 15.

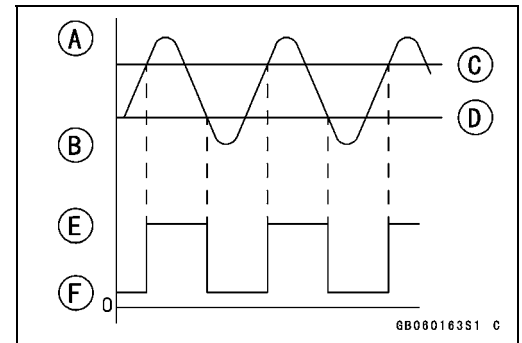

1-24 GENERAL INFORMATION

Technical Information - Alternator Made from Rare Magnet

Rare Magnet Material

Sintered metal made from mainly neodium (Nd), ferric magnet (Fe), and boron (B).

Main Characters

Rare magnet used and assembled in the alternator for the ZX600-J model has six (6) times higher performance than that of the traditional use ferrite magnet.

This allows the alternator to reduce its mass and weight to the large extent. In addition to above mentioned, there's no use to worry about the future lackage of rare magnetic resources such as samarium cobalt.

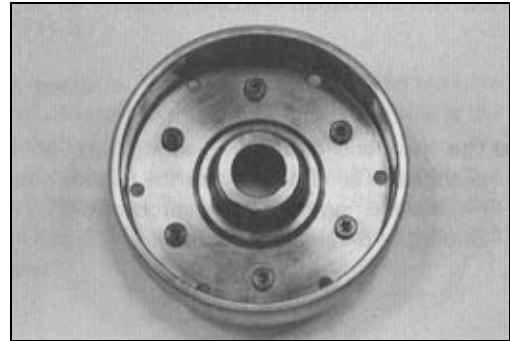

Torque and Locking Agent

The following tables list the tightening torque for the major fasteners requiring use of a non-permanent locking agent or liquid gasket.

Letters used in the "Remarks" column mean:

- L: Apply a non-permanent locking agent to the threads.
- LG: Apply grease to the threads.
- Lh: Left-hand threads.
- M: Apply molybdenum disulfide grease.
- O: Apply oil to the threads and seating surface.
- R: Replacement parts
- S: Tighten the fasteners following the specified sequence.
- SS: Apply silicone sealant.
- St: Stake the fasteners to prevent loosening.

Fastener	Torque			Remarks
	N·m	kgf·m	ft·lb	
Fuel System				
Vacuum Valve Drain Screw	1.0	0.10	9 in·lb	
Fuel Tap Bolts	4.9	0.50	43 in·lb	with black washer
Fuel Tap Bolts	2.5	0.25	22 in·lb	with white washer
Cooling System				
Water Hose Clamp Screws	2.0	0.20	17 in·lb	
Coolant By-pass Fitting	9.8	1.0	87 in·lb	L
Coolant Drain Plug (Water Pump)	9.8	1.0	87 in·lb	
Coolant Drain Plugs (Cylinder)	9.8	1.0	87 in·lb	
Radiator Fan Switch	18	1.8	13	
Water Temperature Sensor	7.8	0.80	69 in·lb	SS
Impeller Bolt	9.8	1.0	87 in·lb	
Water Pump Cover Bolts	12	1.2	104 in·lb	L
Thermostat Housing Cover Bolts	5.9	0.60	52 in·lb	
Water Hose Fitting Bolts	11	1.1	95 in·lb	
Engine Top End				
Spark Plugs	13	1.3	113 in·lb	
Air Suction Valve Cover Bolts	12	1.2	104 in·lb	L
Cylinder Head Cover Bolts	9.8	1.0	87 in·lb	
Camshaft Chain Tensioner Mounting Bolts	12	1.2	104 in·lb	
Camshaft Cap Bolts	12	1.2	104 in·lb	
Camshaft Chain Guide Bolts (Upper)	12	1.2	104 in·lb	
Cylinder Head Bolts:				
ϕ 10	49	5.0	36	S, O (Washer)
ϕ 6	12	1.2	104 in·lb	S
Cylinder Head Jacket Plugs (Right)	15	1.5	11	L
Cylinder Head Jacket Plugs (Upper, Left)	20	2.0	14.5	L
Engine Side Cover Bolts	12	1.2	104 in·lb	
Camshaft Chain Guide Bolt (Crankcase)	25	2.5	18	
Carburetor Holder Bolts	12	1.2	104 in·lb	

1-26 GENERAL INFORMATION

Torque and Locking Agent

Fastener	Torque			Remarks
	N·m	kgf·m	ft·lb	
Baffle Plate Bolts	9.8	1.0	87 in·lb	L
Muffler Body and Exhaust Pipe Connecting Nuts	45	4.5	33	
Exhaust Pipe Mounting Bolt	34	3.5	25	
Clutch				
Clutch Cover Bolts	12	1.2	104 in·lb	L (2, Front)
Clutch Cover Damper Bolts	5.9	0.60	52 in·lb	L
Clutch Spring Bolts	8.8	0.90	78 in·lb	
Clutch Hub Nut	137	14	101	R
Engine Lubrication System				
Oil Filler Plug	1.5 or Hand-Tight	0.15 or Hand-Tight	13 in·lb or Hand-Tight	
Engine Drain Plug	20	2.0	14.5	
Oil Filter (Cartridge type)	31	3.2	23	R, O
Oil Cooler Mounting Bolt	78	8.0	58	O
Oil Pan Bolts	9.8	1.0	87 in·lb	
Oil Pipe Holder Bolts	12	1.2	104 in·lb	L
Oil Pressure Relief Valve	15	1.5	11	L
Oil Pressure Switch	15	1.5	11	SS
Oil Pressure Switch Terminal Bolt	1.5	0.15	13 in·lb	
Impeller Bolt	9.8	1.0	87 in·lb	
Oil Passage Plug (Right)	15	1.5	11	
Oil Hose Banjo Bolts	25	2.5	18	
Engine Removal/Installation				
Engine Mounting Bolts and Nuts	44	4.5	33	
Engine Mounting Locknuts	49	5.0	36	
Engine Mounting Bracket Bolts	25	2.5	18	
Crankshaft/Transmission				
Breather Plate Bolts	9.8	1.0	87 in·lb	L
Breather Tube Bracket Bolts	12	1.2	104 in·lb	
Crankcase Bolts:				
ϕ 8	30	3.0	22	S
ϕ 7	20	2.0	14.5	S
ϕ 6, L38 (Front, 6)	18	1.8	13	S
ϕ 6	12	1.2	104 in·lb	S
Oil Passage Plug (Left)	20	2.0	14.5	L
Oil Passage Plug (Right)	15	1.5	11	
Connecting Rod Big End Nuts	in the text	←	←	←
Engine Ground Lead Terminal Bolt	9.8	1.0	87 in·lb	
Timing Rotor Bolt	44	4.5	33	
Oil Pressure Switch	15	1.5	11	SS
Gear Positioning Lever Bolt	12	1.2	104 in·lb	
Shift Shaft Return Spring Pin (Bolt)	28	2.9	21	L

Torque and Locking Agent

Fastener	Torque			Remarks
	N·m	kgf·m	ft·lb	
Neutral Switch	15	1.5	11	
Shift Drum Bearing Holder Bolt	12	1.2	104 in·lb	L
Shift Drum Bearing Holder Screw	4.9	0.5	43 in·lb	L
Shift Drum Cam Bolt	12	1.2	104 in·lb	L
Oil Pipe Holder Bolts	12	1.2	104 in·lb	L
Crankshaft Sensor Cover Bolts	12	1.2	104 in·lb	L (1)
Oil Nozzles	6.9	0.70	61 in·lb	L
Starter Motor Clutch Bolt	34	3.5	25	L
Wheels/Tires				
Front Axle Clamp Bolts	20	2.0	14.5	
Front Axle Nut	127	13	94	
Rear Axle Nut	127	13	94	
Final Drive				
Engine Sprocket Nut	127	13	94	O
Engine Sprocket Cover Bolts	12	1.2	104 in·lb	
Speed Sensor Mounting Bolt	6.9	0.70	61 in·lb	L
Rear Sprocket Nuts	59	6.0	43	
Rear Sprocket Studs	–	–	–	L
Brakes				
Bleed Valves	7.8	0.80	69 in·lb	
Brake Hose Banjo Bolts	25	2.5	18	
Brake Lever Pivot Bolt	1.0	0.10	9 in·lb	
Brake Lever Pivot Bolt Locknut	5.9	0.60	52 in·lb	
Front Brake Reservoir Cap Stopper Screw	1.5	0.15	13 in·lb	
Front Brake Reservoir Bracket Bolt	6.9	0.70	61 in·lb	
Front Brake Light Switch Screws	1.0	0.10	9 in·lb	
Front Master Cylinder Clamp Bolts				
ZX600J1 ~ J4, J6F	8.8	0.90	78 in·lb	S
ZX600J7F	11	1.1	97 in·lb	S
Front Brake Pad Spring Bolts	2.9	0.30	26 in·lb	
Front Caliper Mounting Bolts	34	3.5	25	
Front Caliper Assembly Bolts	21	2.1	15	
Brake Disc Mounting Bolts	27	2.8	20	L
Rear Caliper Mounting Bolts	25	2.5	18	
Rear Master Cylinder Mounting Bolts	25	2.5	18	
Rear Master Cylinder Push Rod Locknut	18	1.8	13	
Suspension				
Front Fork Clamp Bolts (Upper)	20	2.0	14.5	
Front Fork Clamp Bolts (Lower)	20	2.0	14.5	
Front Fork Top Plugs	23	2.3	16.5	
Piston Rod Nut	28	2.9	21	
Front Fork Bottom Allen Bolt	39	4.0	29	L
Front Axle Clamp Bolts	20	2.0	14.5	

1-28 GENERAL INFORMATION

Torque and Locking Agent

Fastener	Torque			Remarks
	N·m	kgf·m	ft·lb	
Rear Shock Absorber Nuts (Upper and Lower)	34	3.5	25	
Rear Shock Absorber Upper Bracket Nut	59	6.0	43	
Swingarm Pivot Shaft Nut	108	11	80	
Uni-Trak:				
Rocker Arm Nut	34	3.5	25	
Tie-Rod Nuts	59	6.0	43	
Steering				
Steering Stem Head Nut	49	5.0	36	
Steering Stem Locknut	4.9	0.5	43 in·lb	
Steering Stem Nut	15	1.5	11	
Handlebar Bolts	34	3.5	25	L
Handlebar Holder Bolts	25	2.5	18	
Handlebar Holder Position Bolts	9.8	1.0	87 in·lb	L
Handlebar Weight Screws	–	–	–	L
Handlebar Switch Housing Screws	3.5	0.35	30 in·lb	
Frame				
Footpeg Mounting Bolts	34	3.5	25	L
Side Stand Mounting Bolt	44	4.5	33	
Grab Rail Bolts	25	2.5	18	
Footpeg Bracket Mounting Bolts	25	2.5	18	
Side Stand Bracket Bolts	49	5.0	36	
Rear Frame Bolts and Nuts	44	4.5	33	
Rear Shock Absorber Upper Bracket Nut	59	6.0	43	
Electrical System				
Spark Plugs	13	1.3	113 in·lb	
Alternator Rotor Bolt	120	12	87	
Stator Coil Bolts	12	1.2	104 in·lb	L
Alternator Lead Holding Plate Bolts	6.9	0.70	61 in·lb	L
Engine Ground Lead Terminal Bolt	9.8	1.0	87 in·lb	
Alternator Cover Bolts	12	1.2	104 in·lb	
Crankshaft Sensor Coil Cover Bolts	12	1.2	104 in·lb	L (1)
Crankshaft Sensor Coil Bolts	5.9	0.60	52 in·lb	
Timing Rotor Bolt	44	4.5	33	
Starter Motor Mounting Bolts	12	1.2	104 in·lb	
Handlebar Switch Housing Screws	3.4	0.35	30 in·lb	
Radiator Fan Switch	18	1.8	13	
Water Temperature Sensor	7.8	0.80	69 in·lb	SS
Oil Pressure Switch	15	1.5	11	SS
Oil Pressure Switch Terminal Bolt	1.5	0.15	13 in·lb	
Neutral Switch	15	1.5	11	
Starter Lockout Switch Screws	1.0	0.10	9 in·lb	
Front Brake Light Switch Screws	1.0	0.10	9 in·lb	

GENERAL INFORMATION 1-29

Torque and Locking Agent

Fastener	Torque			Remarks
	N·m	kgf·m	ft·lb	
Throttle Sensor Mounting Screws	3.4	0.35	30 in·lb	
Side Stand Switch Bolt	8.8	0.90	78 in·lb	

1-30 GENERAL INFORMATION

Torque and Locking Agent

The table below, relating tightening torque to thread diameter, lists the basic torque for the bolts and nuts. Use this table for only the bolts and nuts which do not require a specific torque value. All of the values are for use with dry solvent-cleaned threads.

Basic Torque for General Fasteners

Threads dia. (mm)	Torque		
	N·m	kgf·m	ft·lb
5	3.4 ~ 4.9	0.35 ~ 0.50	30 ~ 43 in·lb
6	5.9 ~ 7.8	0.60 ~ 0.80	52 ~ 69 in·lb
8	14 ~ 19	1.4 ~ 1.9	10.0 ~ 13.5
10	25 ~ 34	2.6 ~ 3.5	19.0 ~ 25
12	44 ~ 61	4.5 ~ 6.2	33 ~ 45
14	73 ~ 98	7.4 ~ 10.0	54 ~ 72
16	115 ~ 155	11.5 ~ 16.0	83 ~ 115
18	165 ~ 225	17.0 ~ 23.0	125 ~ 165
20	225 ~ 325	23 ~ 33	165 ~ 240

Special Tools and Sealant

Bearing Puller:
57001-135

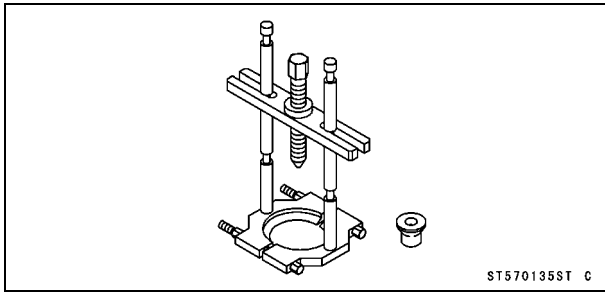

Valve Spring Compressor Assembly:
57001-241

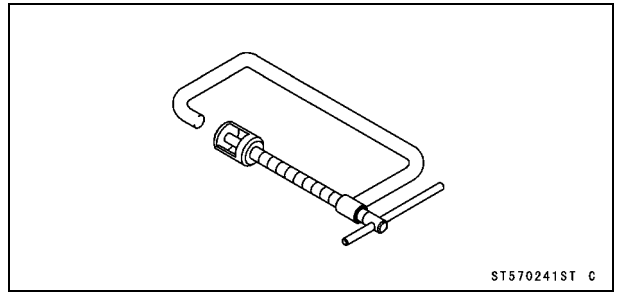

Inside Circlip Pliers:
57001-143

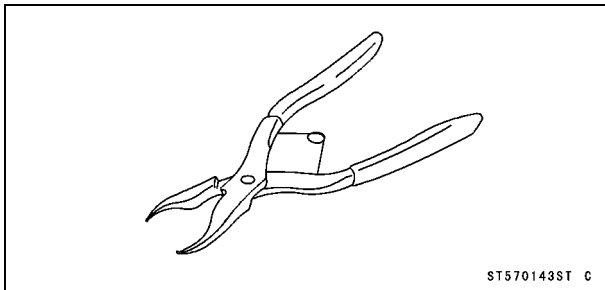

Bearing Puller Adapter:
57001-317

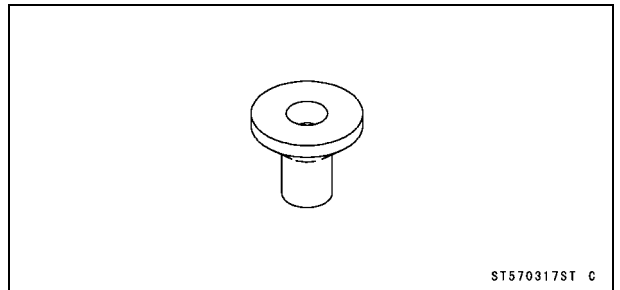

Outside Circlip Pliers:
57001-144

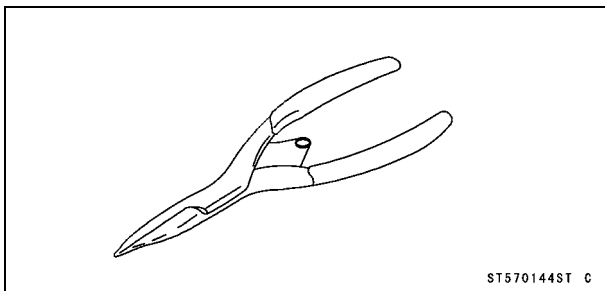

Piston Pin Puller Assembly:
57001-910

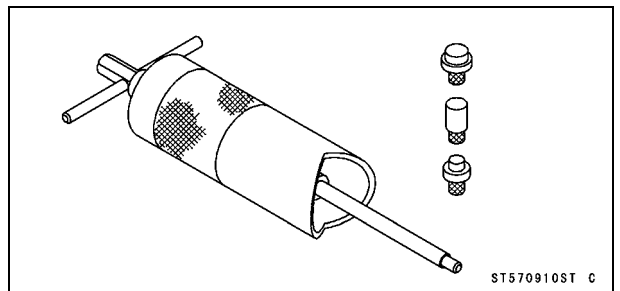

Oil Pressure Gauge, 10 kgf/cm²:
57001-164

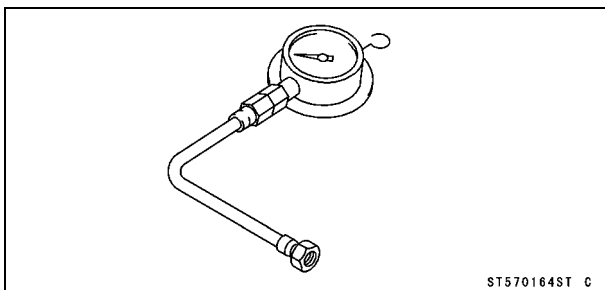

Fuel Level Gauge:
57001-1017

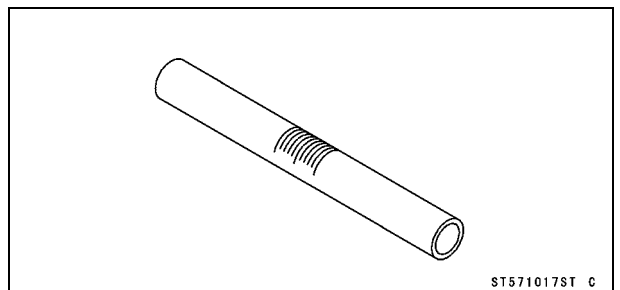

Compression Gauge, 20 kgf/cm²:
57001-221

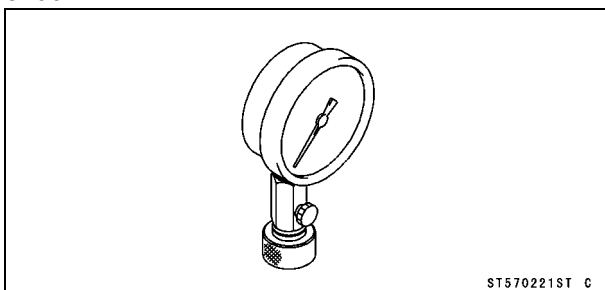

Oil Seal & Bearing Remover:
57001-1058

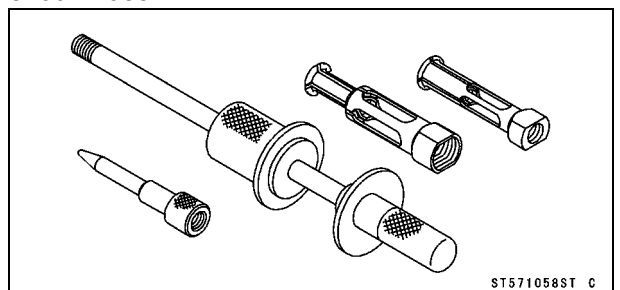

1-32 GENERAL INFORMATION

Special Tools and Sealant

Head Pipe Outer Race Press Shaft:

57001-1075

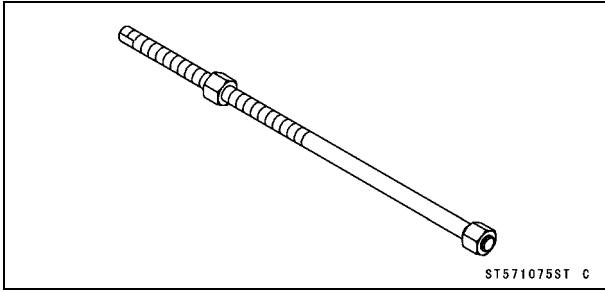

ST571075ST C

Valve Seat Cutter, 32° - ϕ 28:

57001-1119

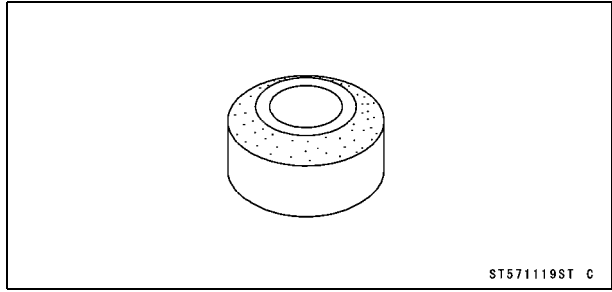

ST571119ST C

Steering Stem Nut Wrench:

57001-1100

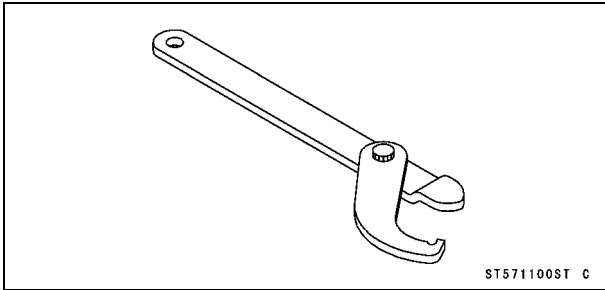

ST571100ST C

Valve Seat Cutter, 32° - ϕ 30:

57001-1120

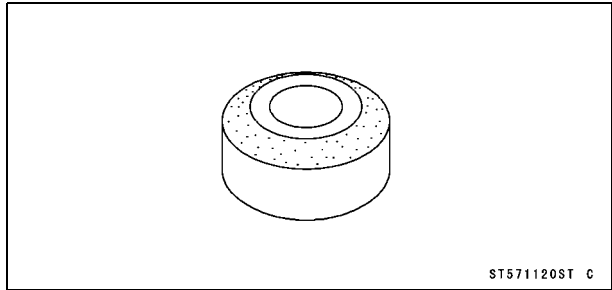

ST571120ST C

Hook Wrench R37.5, R42:

57001-1101

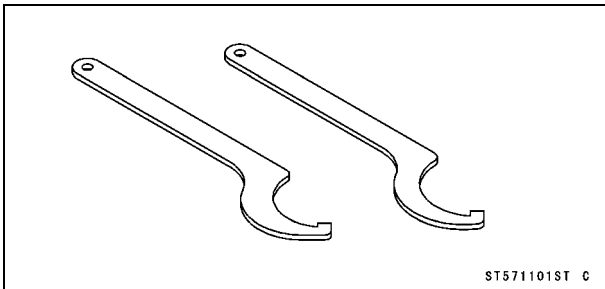

ST571101ST C

Valve Seat Cutter, 60° - ϕ 30:

57001-1123

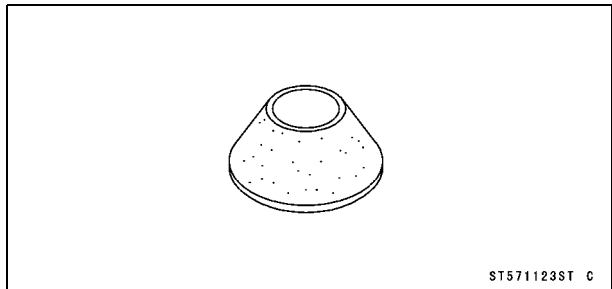

ST571123ST C

Valve Seat Cutter, 45° - ϕ 27.5:

57001-1114

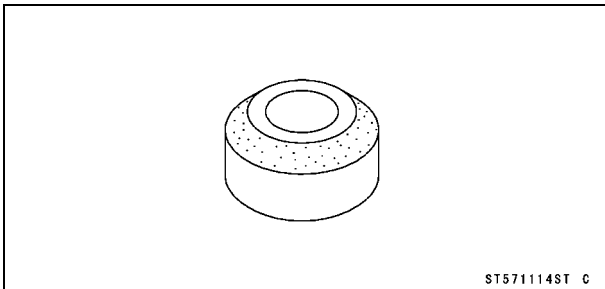

ST571114ST C

Valve Seat Cutter Holder Bar:

57001-1128

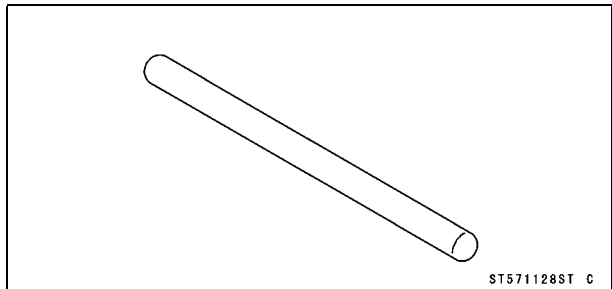

ST571128ST C

Valve Seat Cutter, 45° - ϕ 32:

57001-1115

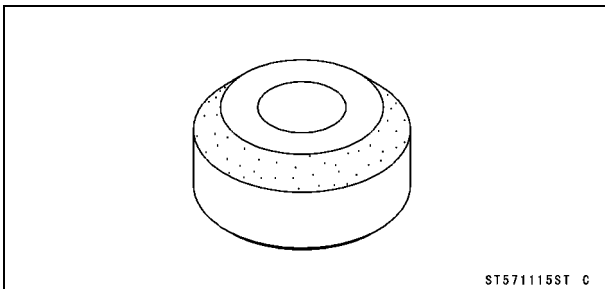

ST571115ST C

Bearing Driver Set:

57001-1129

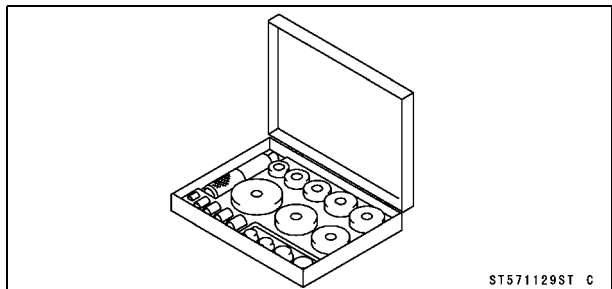

ST571129ST C

Special Tools and Sealant

Valve Spring Compressor Adapter, $\phi 20$:
57001-1154

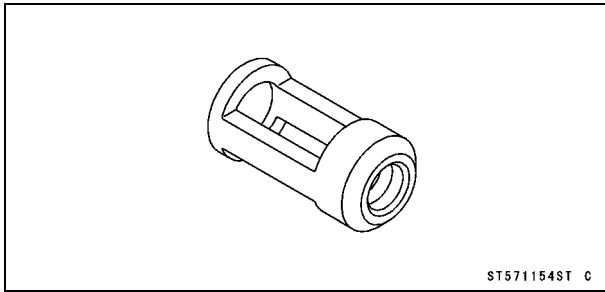

ST571154ST C

Pilot Screw Adjuster, A:
57001-1239

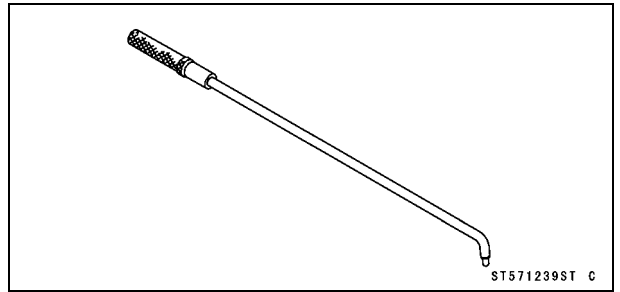

ST571239ST C

Valve Spring Compressor Adapter, $\phi 22$:
57001-1202

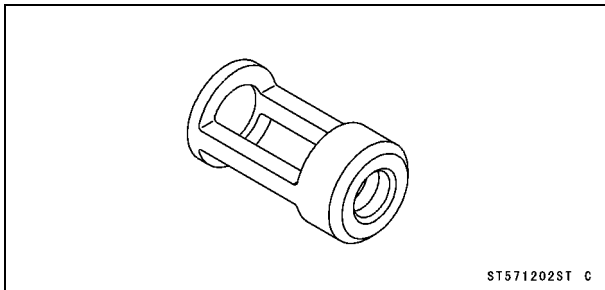

ST571202ST C

Clutch Holder:
57001-1243

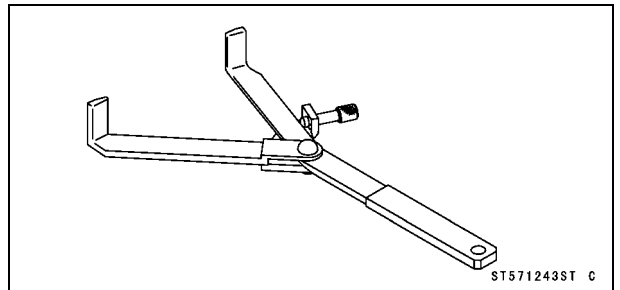

ST571243ST C

Fork Outer Tube Weight:
57001-1218

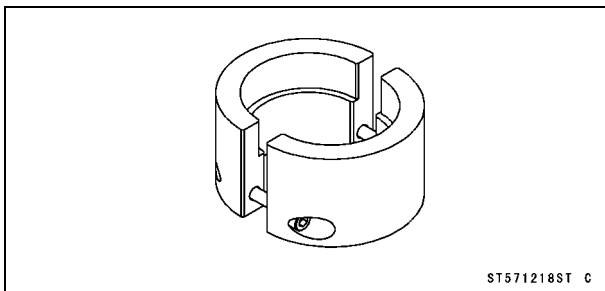

ST571218ST C

Oil Filter Wrench:
57001-1249

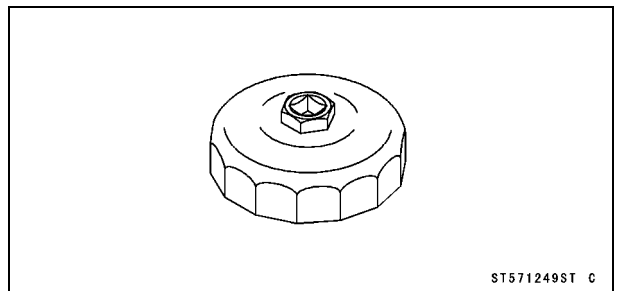

ST571249ST C

Front Fork Oil Seal Driver:
57001-1219

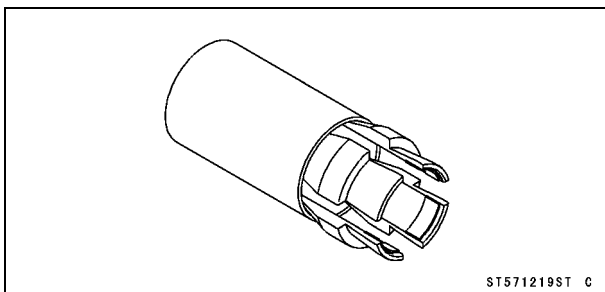

ST571219ST C

Spark Plug Wrench, Hex 16:
57001-1262

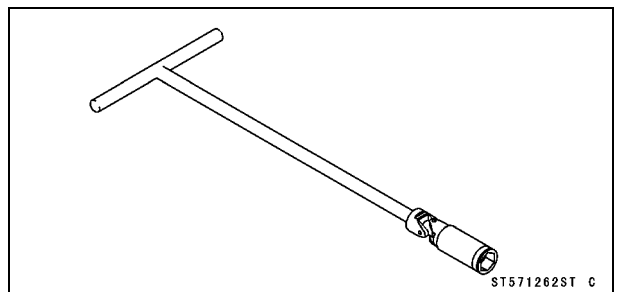

ST571262ST C

Jack:
57001-1238

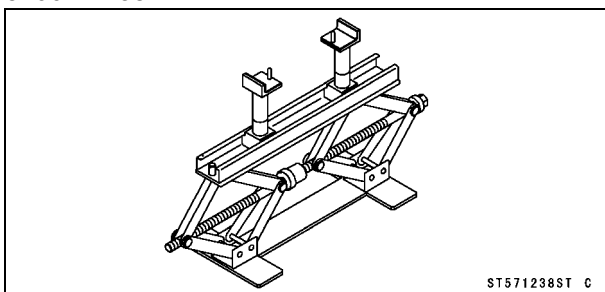

ST571238ST C

Carburetor Drain Plug Wrench, Hex 3:
57001-1269

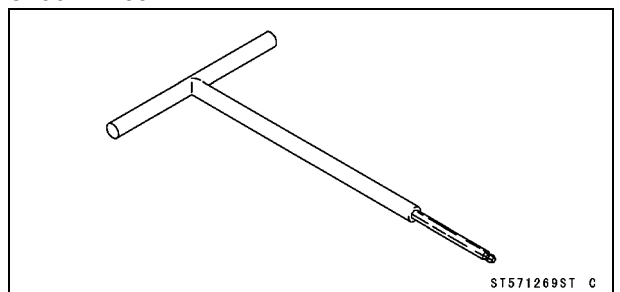

ST571269ST C

1-34 GENERAL INFORMATION

Special Tools and Sealant

Valve Guide Arbor, $\phi 4$:

57001-1273

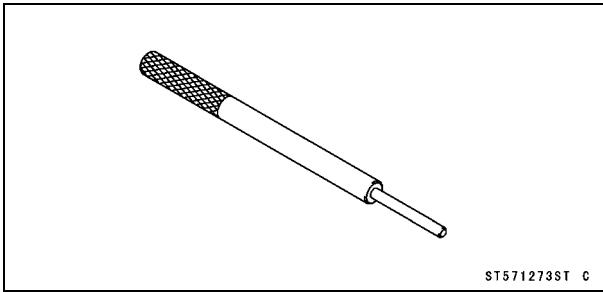

Fork Oil Level Gauge:

57001-1290

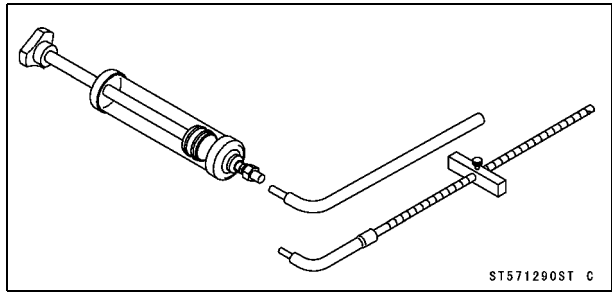

Valve Guide Reamer, $\phi 4$:

57001-1274

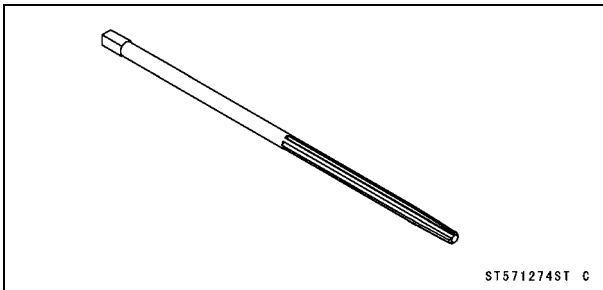

Flywheel Holder:

57001-1313

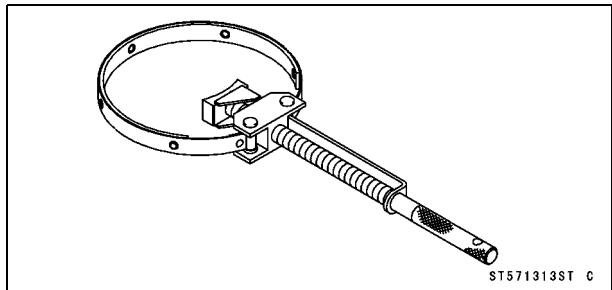

Valve Seat Cutter Holder, $\phi 4$:

57001-1275

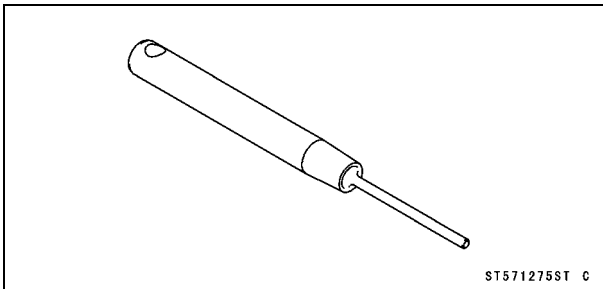

Compression Gauge Adapter, M10 × 1.0:

57001-1317

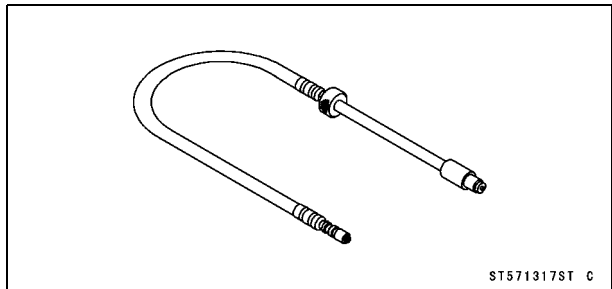

Oil Pressure Gauge Adapter, M18 × 1.5:

57001-1278

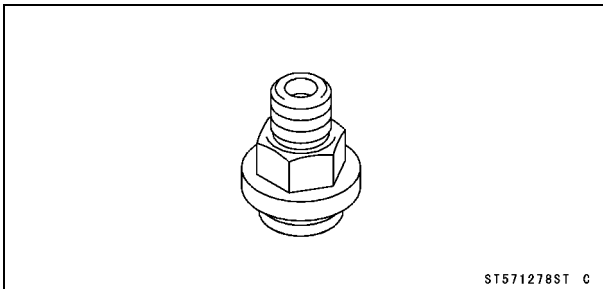

Valve Seat Cutter, 60° - $\phi 33$:

57001-1334

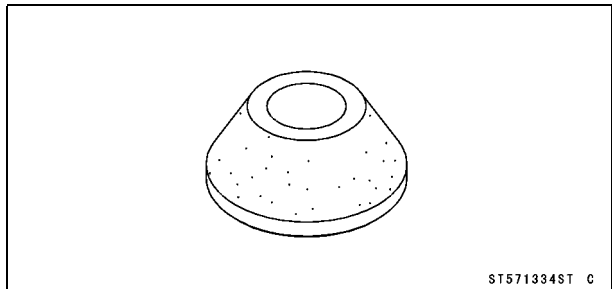

Fork Piston Rod Puller, M12 × 1.25:

57001-1289

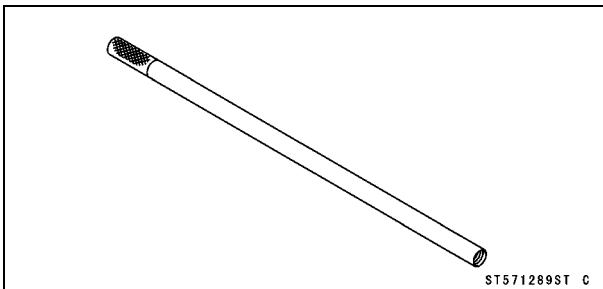

Steering Stem Bearing Driver, $\phi 42.5$:

57001-1344

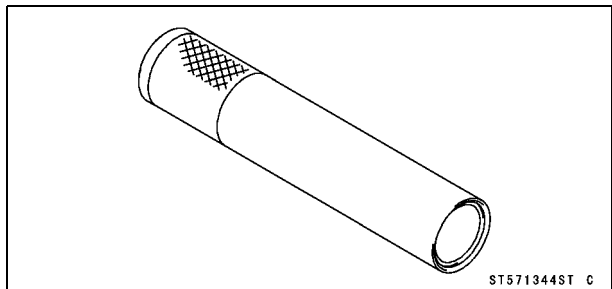

Special Tools and Sealant

Steering Stem Bearing Driver Adapter, $\phi 41.5$:
57001-1345

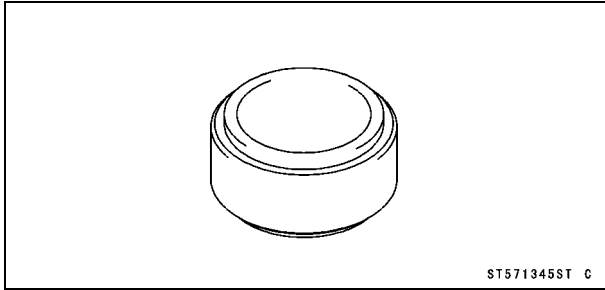

Fork Cylinder Holder, Hex 24 × □19.5:
57001-1406

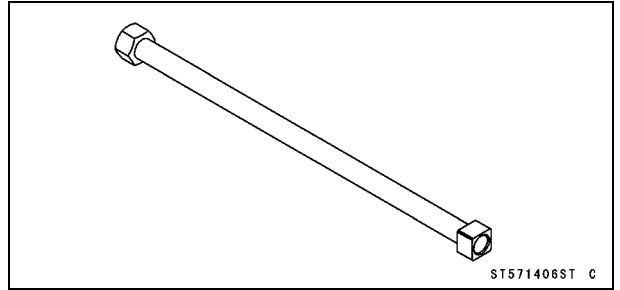

Bearing Remover Head, $\phi 25 \times \phi 28$:
57001-1346

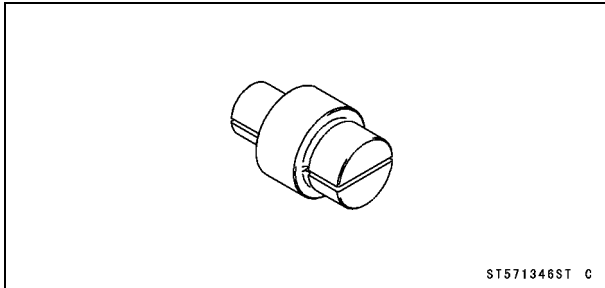

Peak Voltage Adapter:
57001-1415

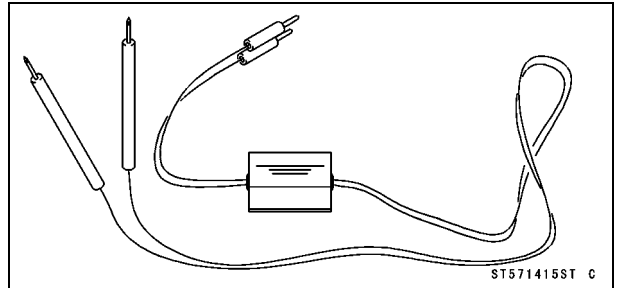

Bearing Remover Shaft, $\phi 13$:
57001-1377

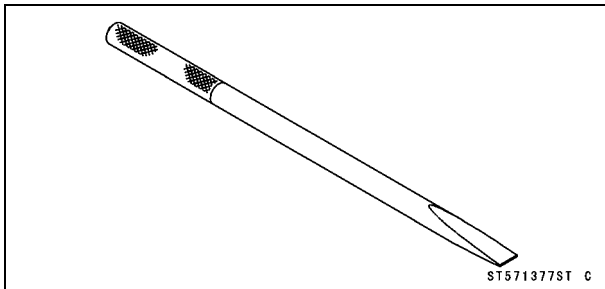

Head Pipe Outer Race Driver, $\phi 55$:
57001-1446

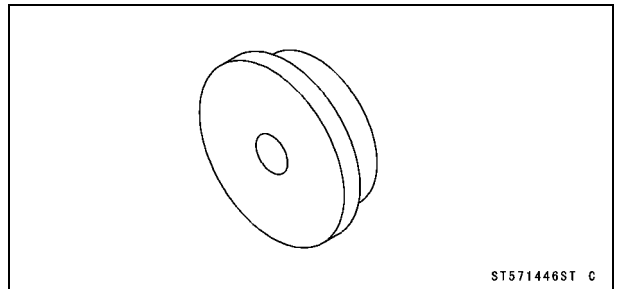

Hand Tester:
57001-1394

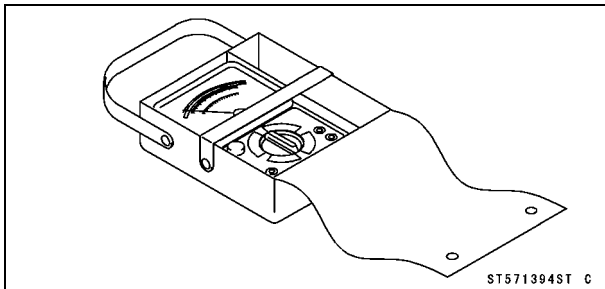

Head Pipe Outer Race Driver, $\phi 47$:
57001-1447

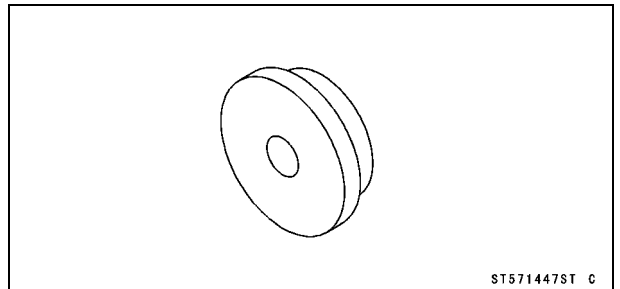

Flywheel Puller Assembly, M38 × 1.5/M35 × 1.5:
57001-1405

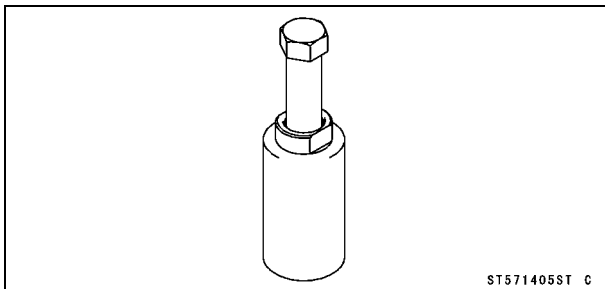

Lead Wire - Peak Voltage Adapter:
57001-1449

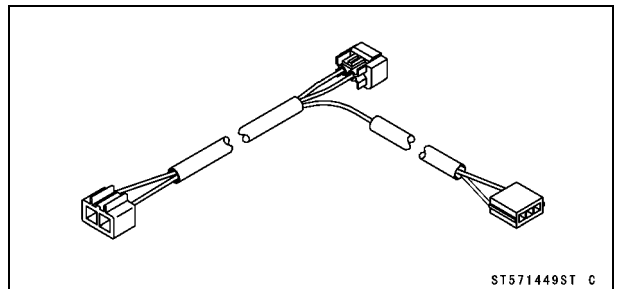

1-36 GENERAL INFORMATION

Special Tools and Sealant

Engine Mount Nut Wrench:

57001-1450

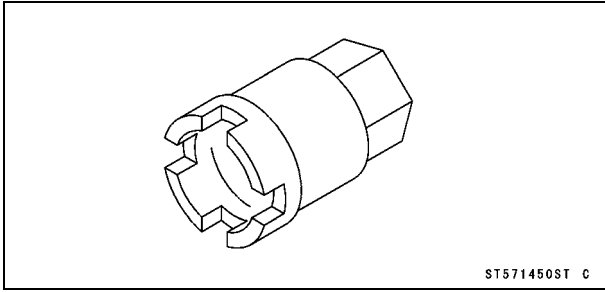

Flywheel & Pulley Holder:

57001-1605

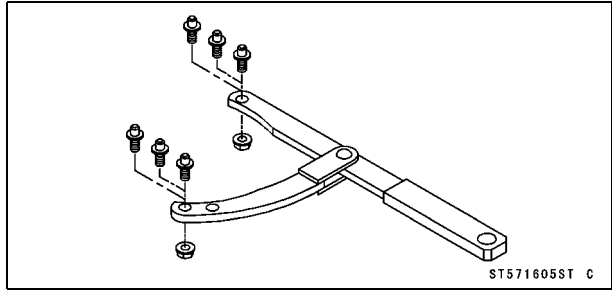

Needle Adapter Set:

57001-1457

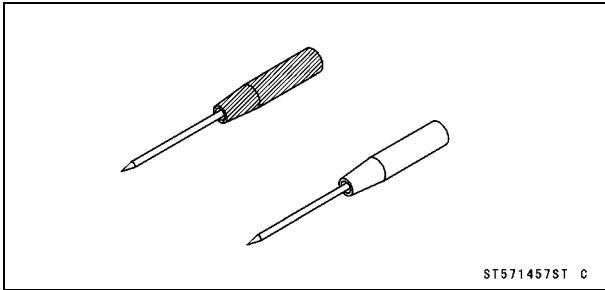

Kawasaki Bond (Silicone Sealant):

56019-120

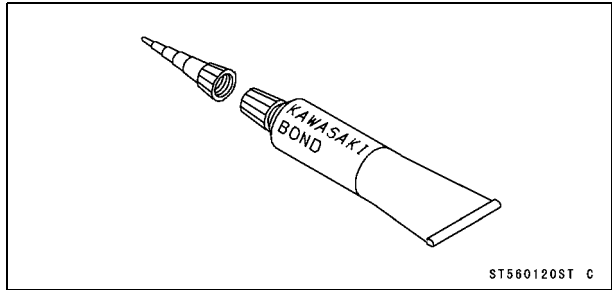

Throttle Sensor Setting Adapter:

57001-1521

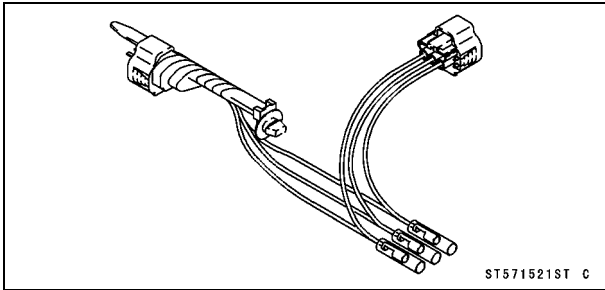

Kawasaki Bond (Liquid Gasket - Gray):

92104-1063

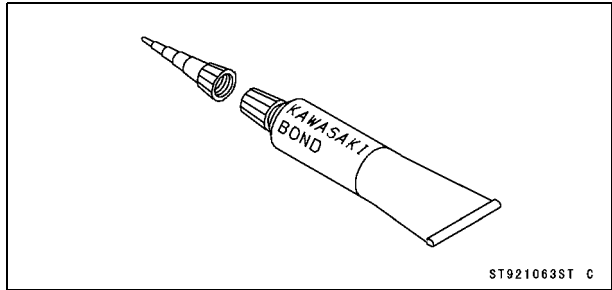

Cable, Wire, and Hose Routing

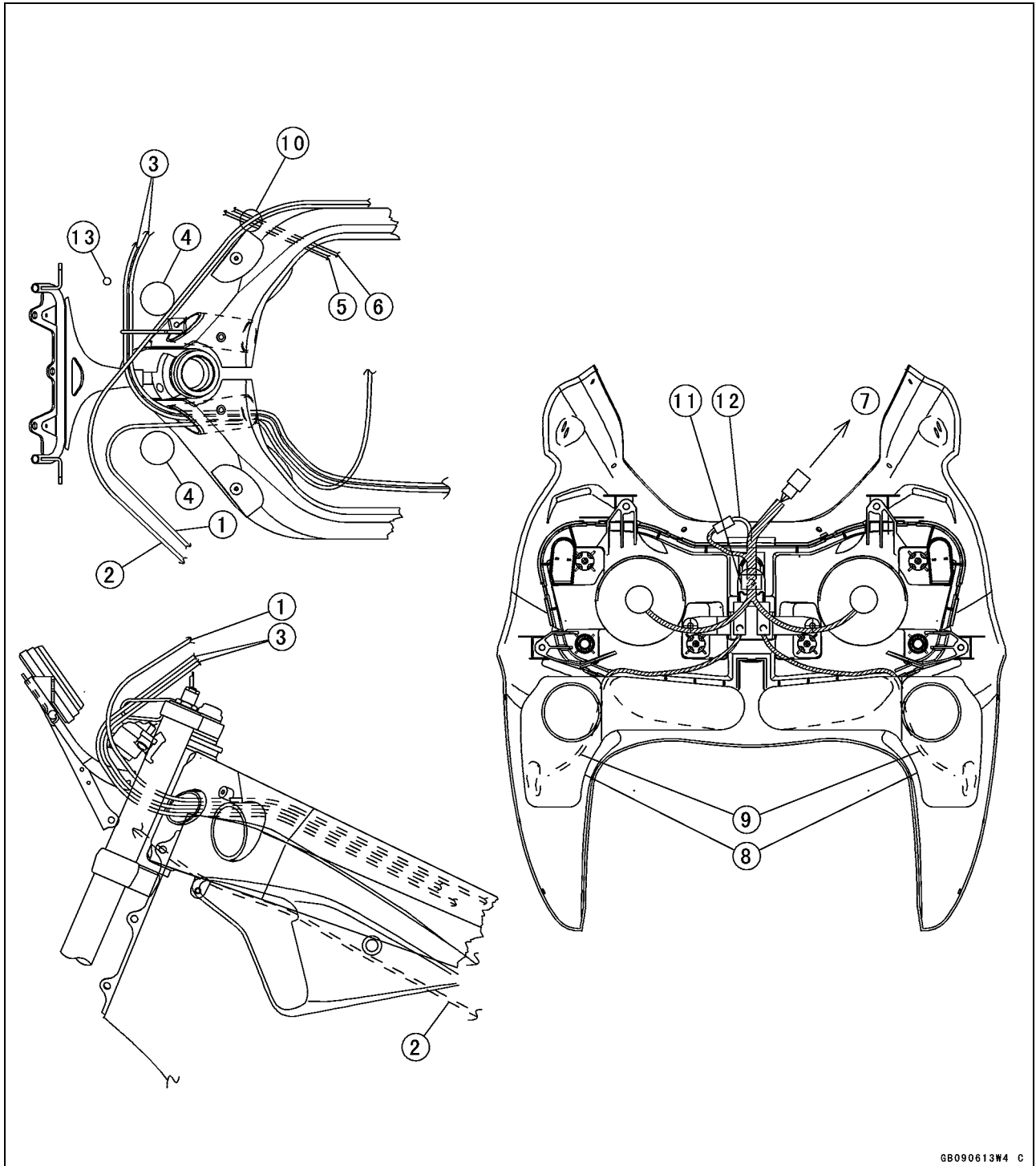

1. Choke Cable
2. Clutch Cable
3. Throttle Cables
4. Front Fork
5. Coolant Reserve Tank Hose
6. Coolant By-pass Hose
7. To Main Harness
8. Air Intake Duct
9. Turn Signal Light Lead
10. Run the clutch cable over the coolant hoses.
11. Clamp
12. City Light Lead
13. Brake Hose

1-38 GENERAL INFORMATION

Cable, Wire, and Hose Routing

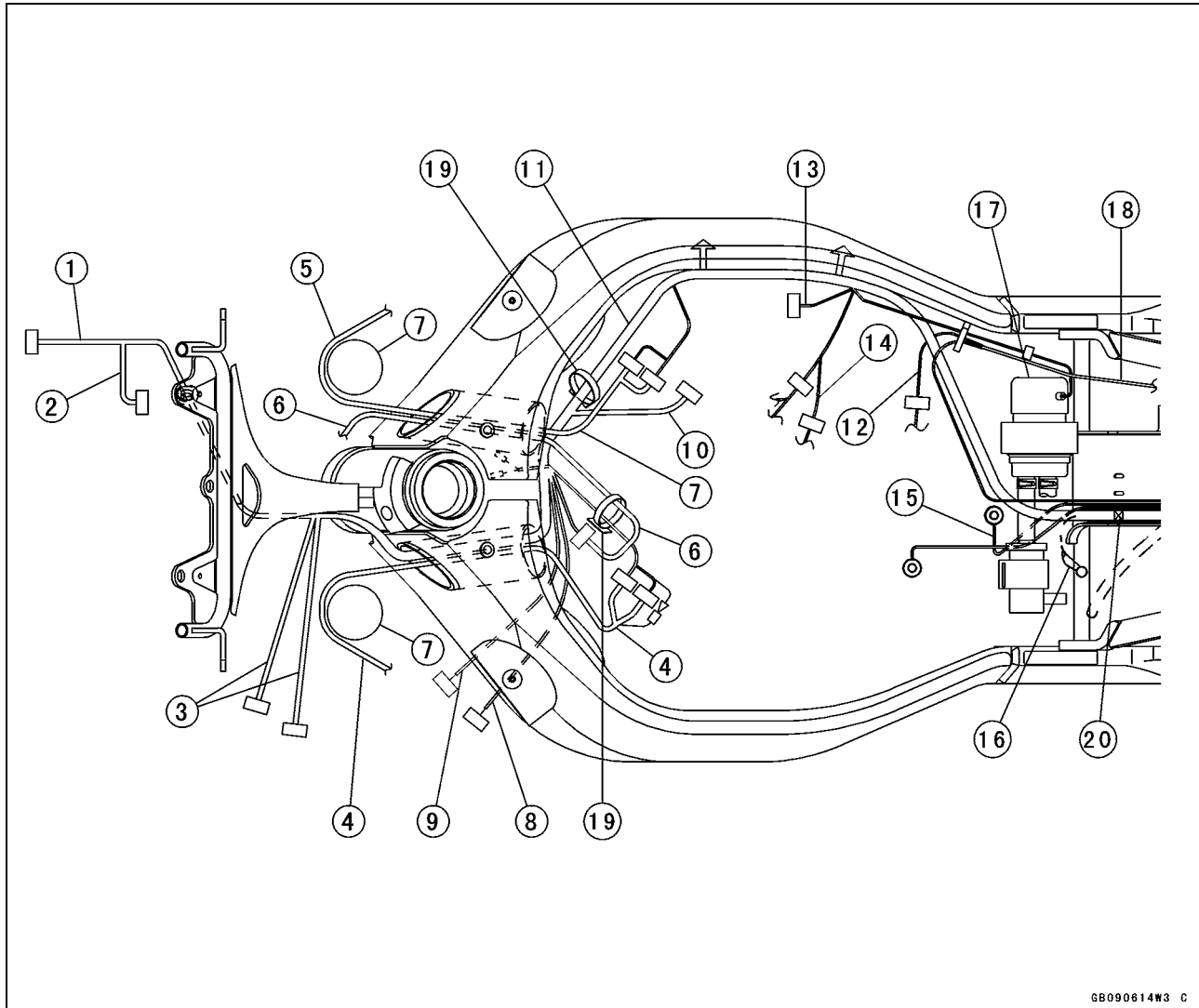

GB090614W3 C

1. Meter Lead
2. Headlight/Turn Signal Light Lead
3. Headlight Relay Lead
4. Left Handlebar Switch Lead
5. Right Handlebar Switch Lead
6. Ignition Switch Lead
7. Front Fork
8. Radiator Fan Motor Lead
9. Radiator Fan Switch Lead
10. Stick Coil Lead
11. Main Harness
12. Alternator Lead
13. Throttle Sensor Lead
14. Speed Sensor Lead
15. Engine Ground
16. Frame Ground
17. Fuel Pump
18. Regulator/Rectifier Lead
19. Clamp
20. Band (Main Harness, Battery Cable, Coolant Reserve Overflow Hose)

Cable, Wire, and Hose Routing

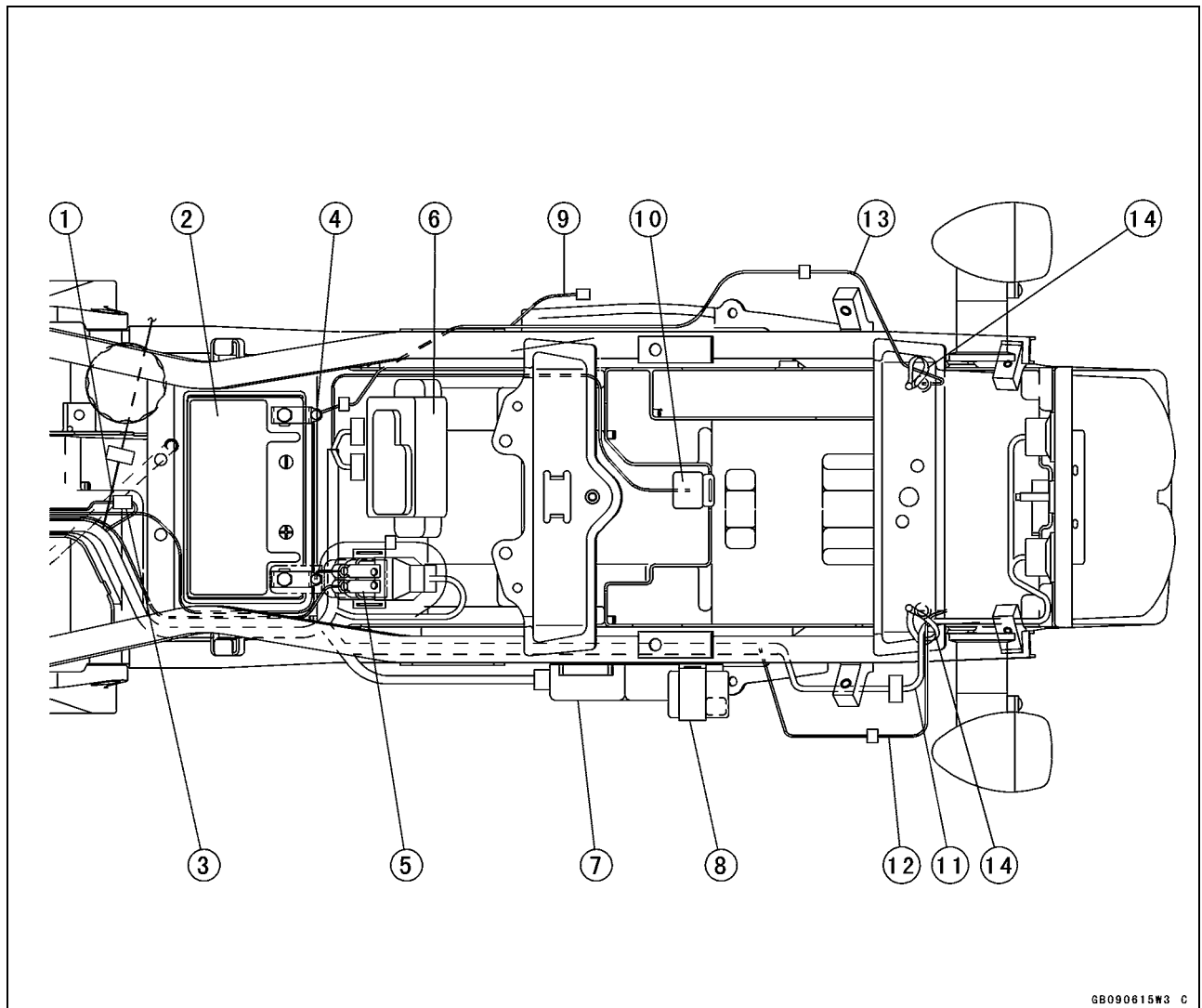

GB090615W3 C

1. Rear Brake Switch Lead
2. Battery
3. Alternator Lead Connector
4. Battery (-) Cable
5. Starter Relay
6. Junction Box
7. IC Igniter
8. Fuel Pump Relay
9. Headlight Fuse Lead
10. Turn Signal Relay
11. Tail/Brake Light Lead
12. Left Turn Signal Light Lead
13. Right Turn Signal Light Lead
14. Clamp

1-40 GENERAL INFORMATION

Cable, Wire, and Hose Routing

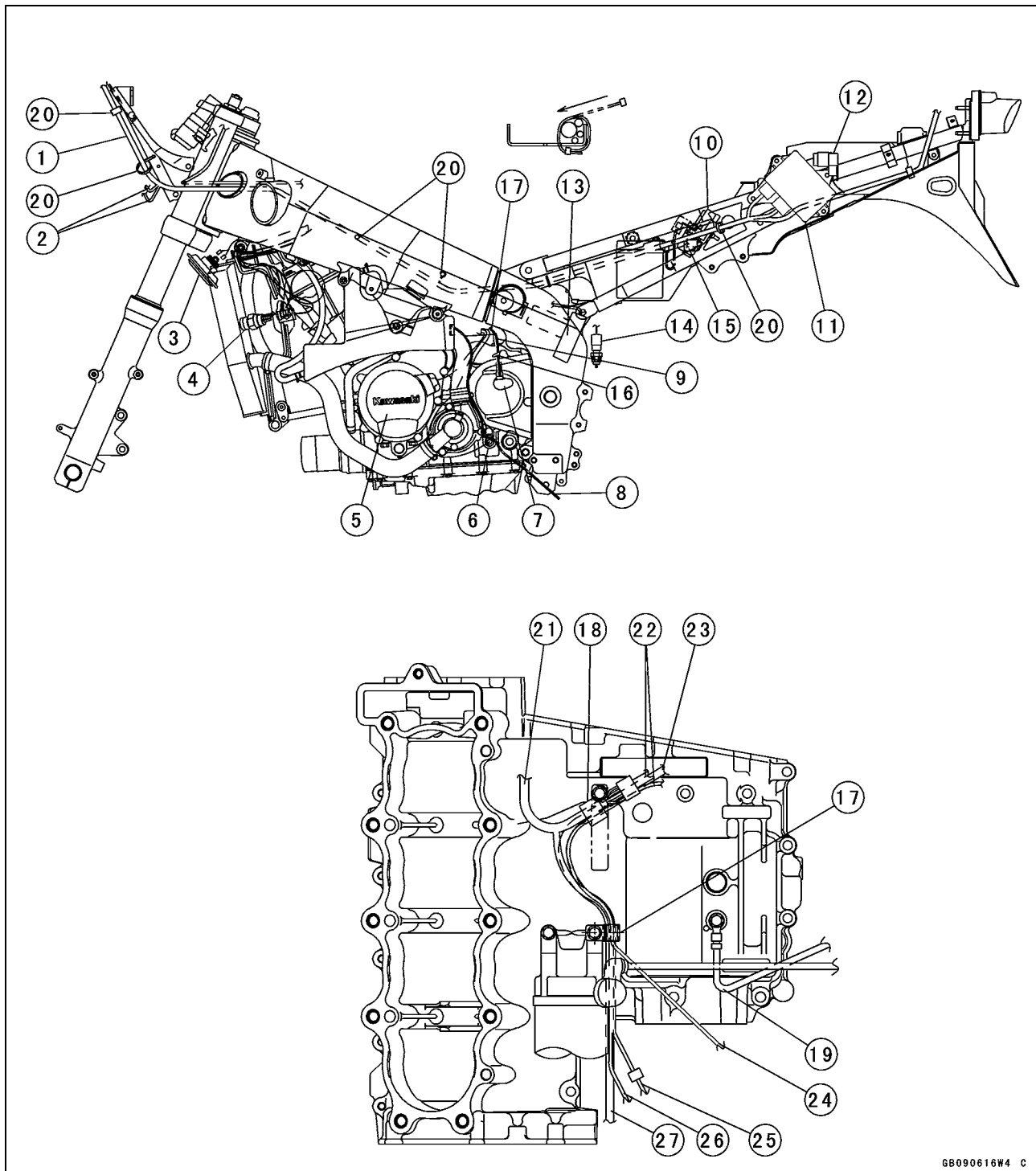

GB090616W4 C

- | | | |
|-------------------------------------|---|-----------------------------------|
| 1. Headlight/Turn Signal Light Lead | 12. Fuel Pump Relay | 19. Engine (Battery) Ground Cable |
| 2. Headlight Relay Lead | 13. Regulator/Rectifier | 20. Clamp |
| 3. Horn | 14. Rear Brake Light Switch | 21. Oil Pressure Switch Lead |
| 4. Radiator Fan Switch | 15. Starter Relay | 22. Main Harness |
| 5. Alternator | 16. Run the speed sensor lead under the clamp. | 23. Regulator/Rectifier Lead |
| 6. Neutral Switch | 17. Clamp (Speed Sensor Lead, Side Stand Switch Lead, Neutral Switch Lead, Alternator Lead) | 24. Speed Sensor Lead |
| 7. Speed Sensor | 18. Clamp (Main Harness, Regulator Lead, Oil Pressure Switch Lead) | 25. Side Stand Switch Lead |
| 8. Side Stand Switch Lead | | 26. Neutral Switch Lead |
| 9. Speed Sensor Lead | | 27. Alternator Lead |
| 10. Junction Box | | |
| 11. IC Igniter | | |

Cable, Wire, and Hose Routing

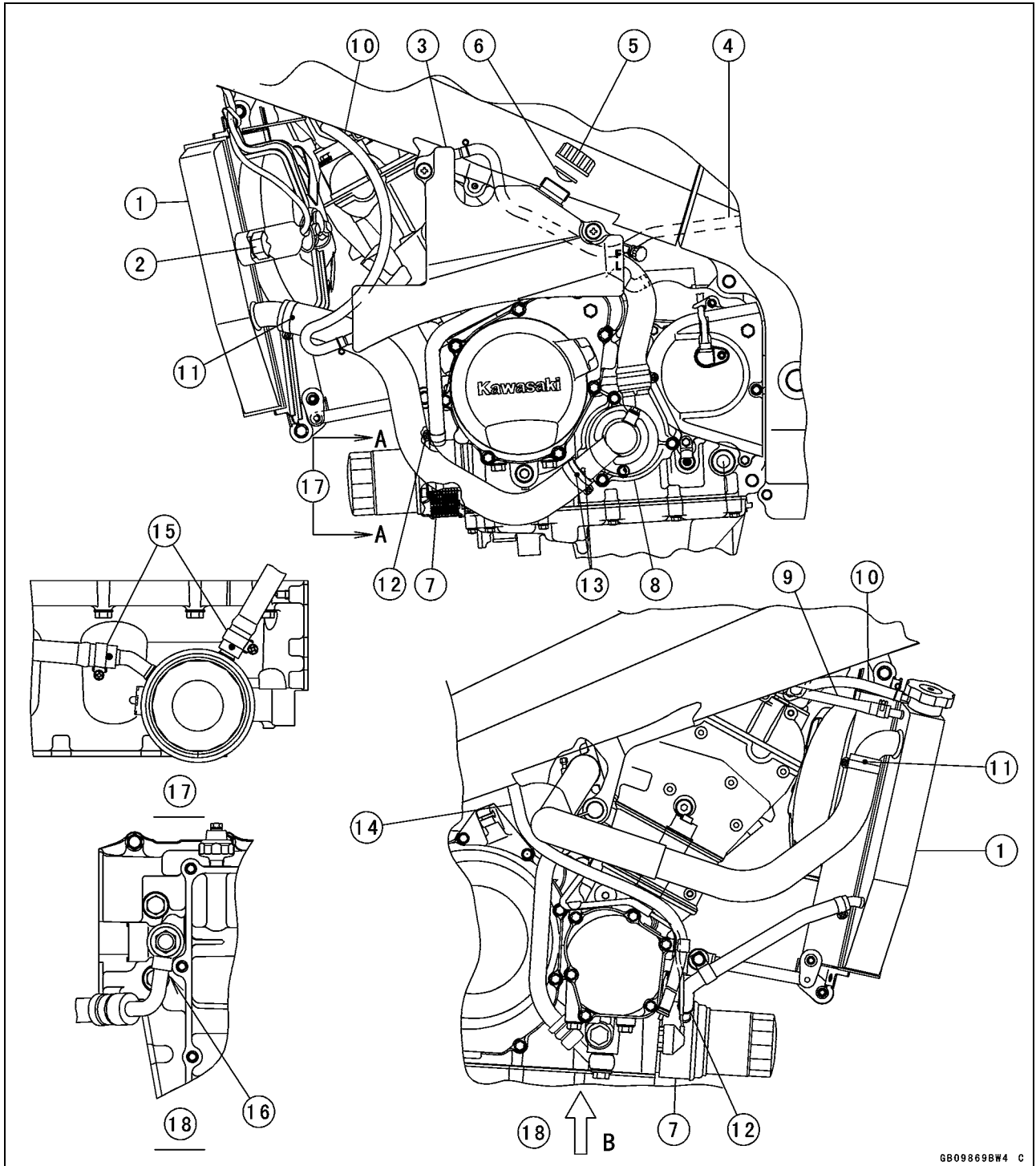

GB09869BW4 C

- | | |
|--|--|
| <ul style="list-style-type: none"> 1. Radiator 2. Radiator Fan Switch 3. Coolant Reserve Tank 4. Reserve Tank Overflow Hose 5. Reserve Tank Cap 6. Rubber Seal 7. Oil Cooler 8. Water Pump 9. Coolant By-pass Hose 10. Reserve Tank Hose | <ul style="list-style-type: none"> 11. Face the white mark outward. 12. Face the white mark forward. 13. Align the marks. 14. Drain Hose (California model only) 15. Install the clamps as shown. 16. The oil hose shall be installed to the lower crankcase so that the hose fitting contact to the case. 17. View from A-A. 18. View from B-B. |
|--|--|

1-42 GENERAL INFORMATION

Cable, Wire, and Hose Routing

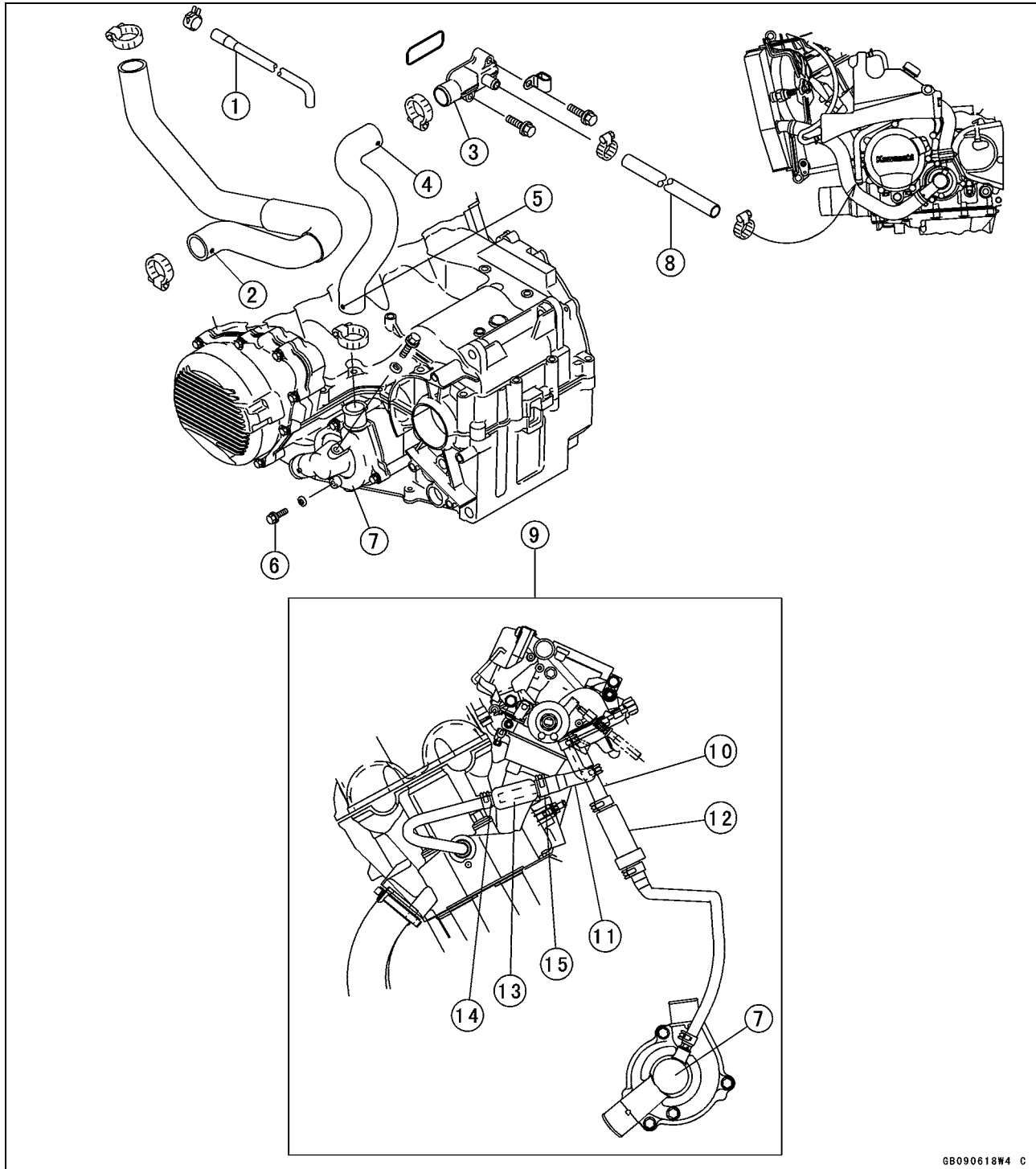

GB090618W4 C

- 1. Coolant By-pass Hose
 - 2. Align the mark on the hose with the projection on the thermostat cover.
 - 3. Cylinder Fitting
 - 4. Align the mark on the hose with the projection on the fitting.
 - 5. Align the mark on the hose with the projection on the water pump cover.
 - 6. Drain Plug
 - 7. Water Pump
 - 8. Oil Cooler Hose (Face the white mark forwards)
 - 9. Other than US, CA Models
 - 10. To #4 Carburetor
 - 11. To #1 Carburetor
 - 12. Coolant Valve
 - 13. Coolant Filter
 - 14. Thin Side
 - 15. Thick Side
- US: United States
CA: Canada

Cable, Wire, and Hose Routing

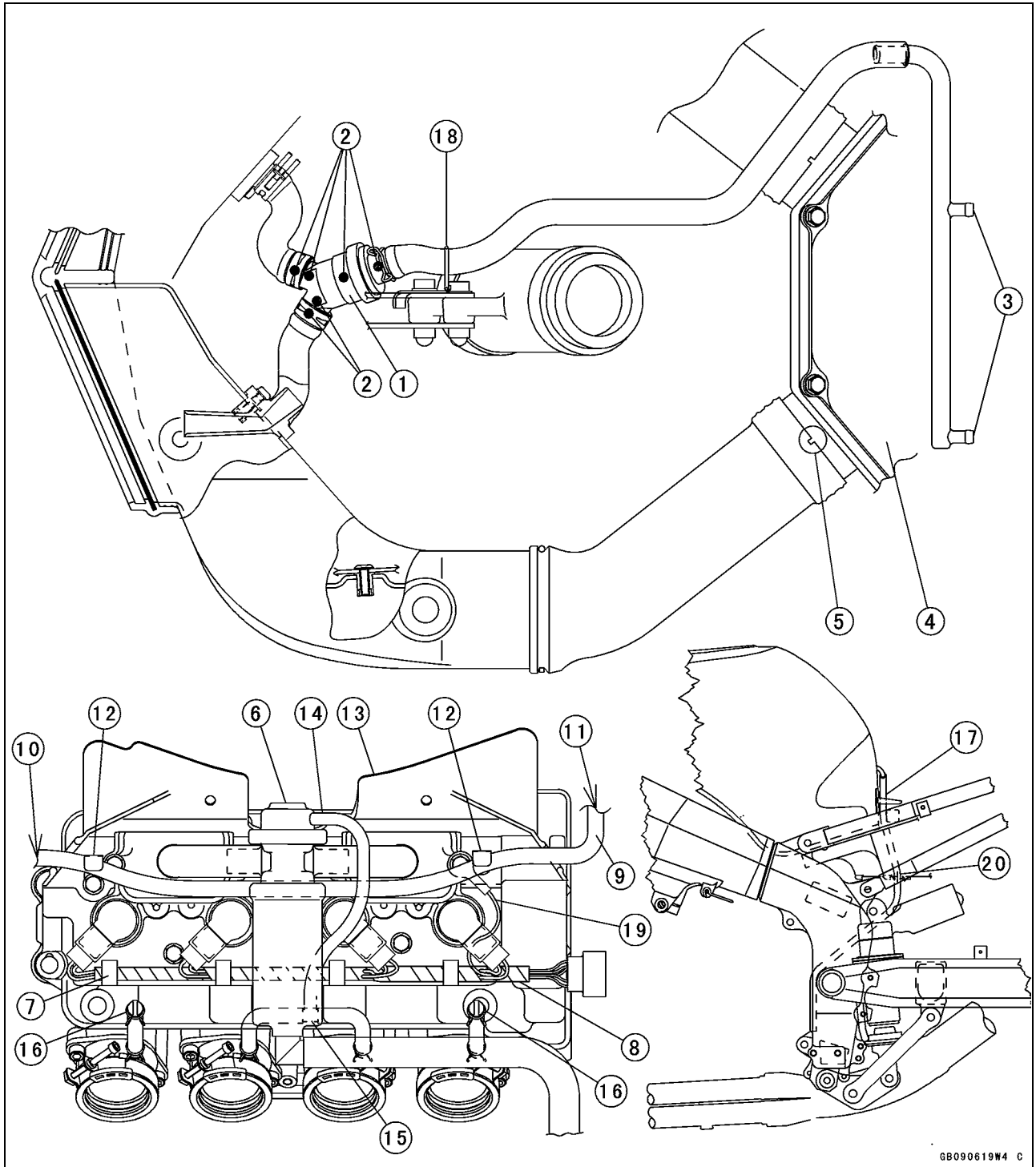

GB090619W4 C

- | | |
|---|---|
| <ol style="list-style-type: none"> 1. Air Vent Filter 2. Align the mark on the hose with the mark on the filter. 3. To Carburetors 4. Air Cleaner Housing 5. Fit the projection of the housing in the recess of the air duct. 6. Vacuum Switch Valve 7. Through the stick coil lead 8. Stick Coil Lead 9. Coolant Reserve Tank Hose 10. To Coolant Reserve Tank | <ol style="list-style-type: none"> 11. To Radiator 12. Install the clamps with the baffle plate. 13. Baffle Plate 14. Vacuum Hose 15. Vacuum Hose Fitting 16. Plug 17. Fuel Tank Drain Hose 18. Clamp (Air Vent Filter Hose) 19. Cylinder Head Cover Ground Lead 20. Run the hose through the hole of the fender. |
|---|---|

1-44 GENERAL INFORMATION

Cable, Wire, and Hose Routing

Front Brake System

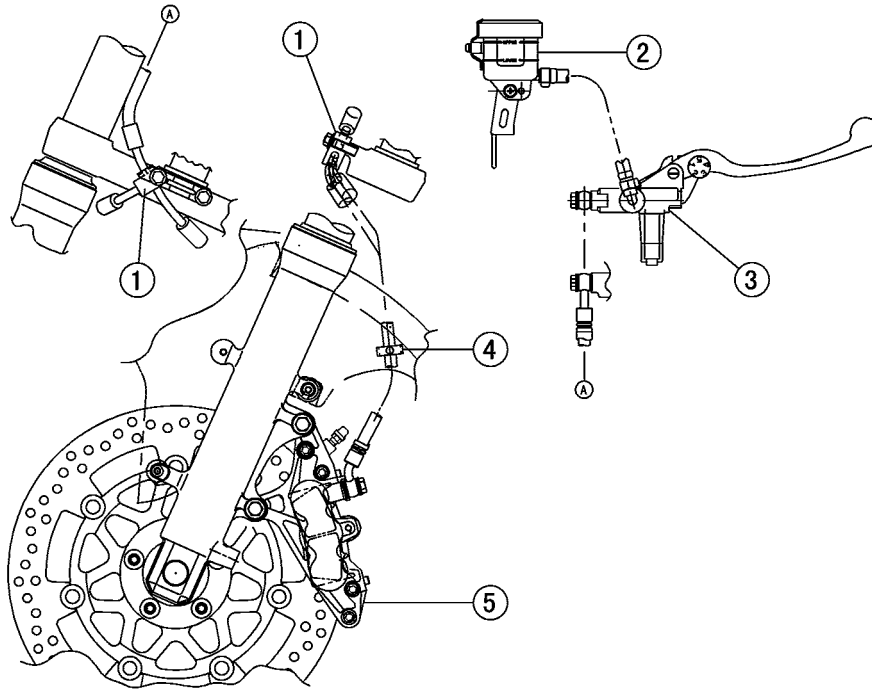

Rear Brake System

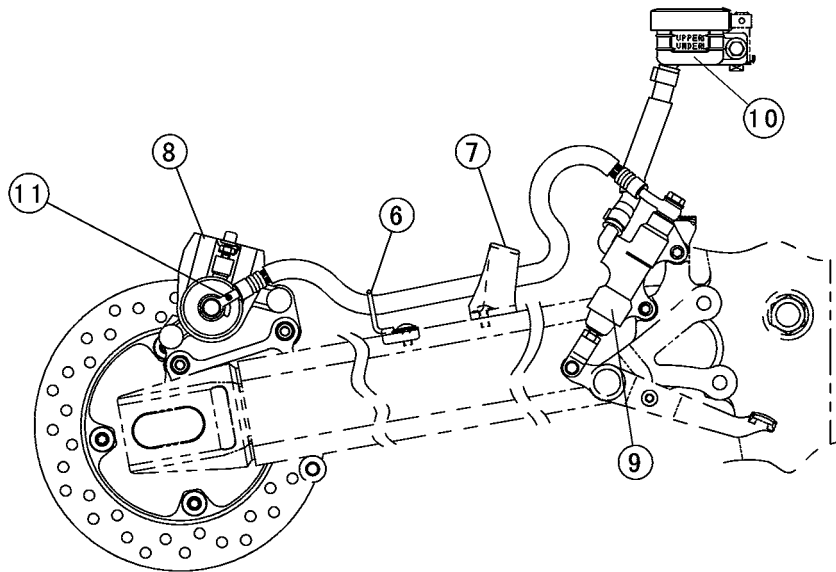

GB090620W4 C

1. Brake Hose Joint
2. Front Brake Reservoir
3. Front Brake Master Cylinder
4. Clamp (Installed to the front fender)
5. Front Brake Caliper
6. Clamp
7. Clamp
8. Rear Brake Caliper
9. Rear Brake Master Cylinder
10. Rear Brake Reservoir
11. The brake hose shall be installed so that the white mark on it faces to outside.

Cable, Wire, and Hose Routing

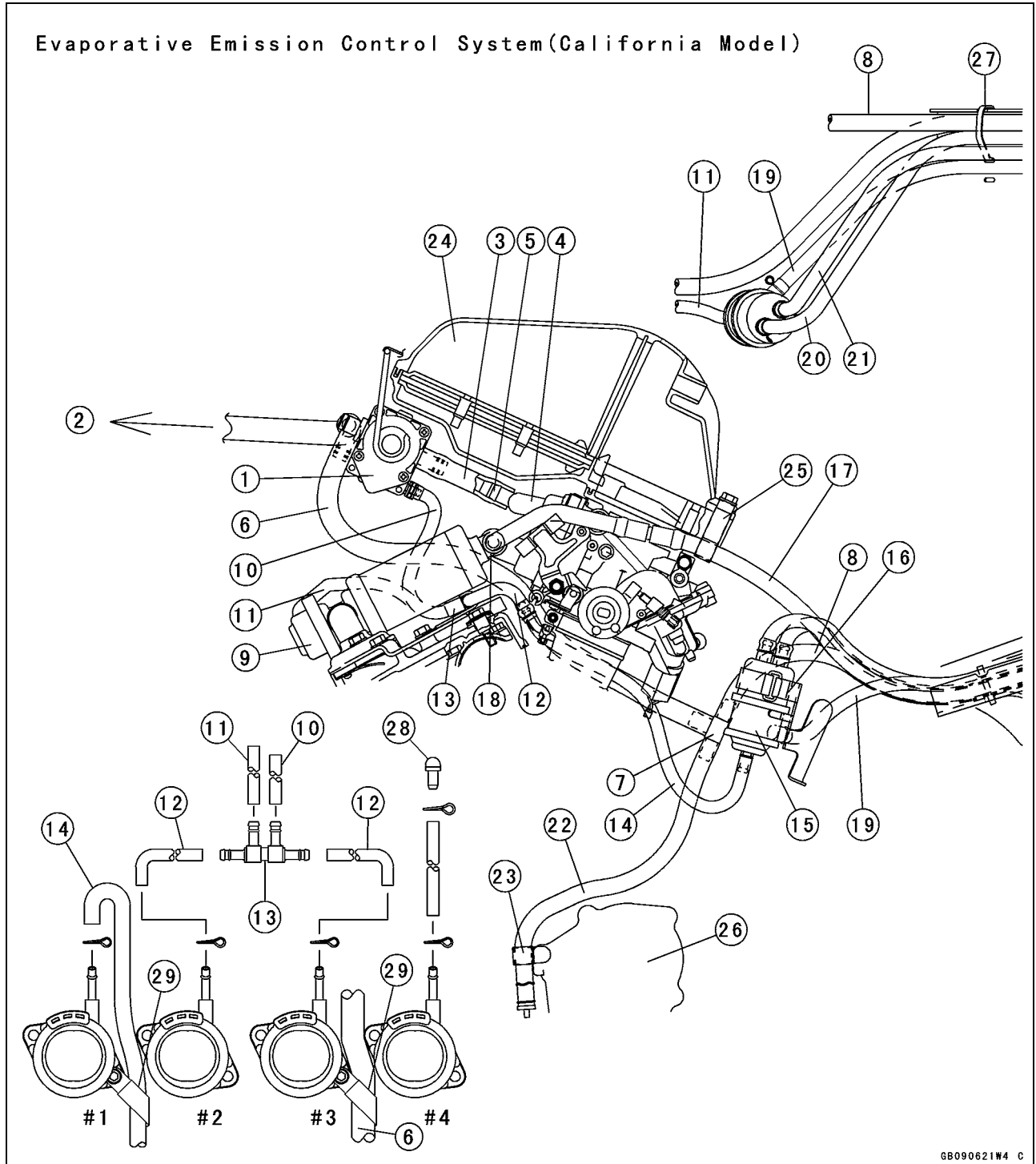

GB090621W4 C

- | | | |
|---|---|---------------------------------------|
| 1. Vacuum Valve | 12. Vacuum Hoses (To #2, #3 Carburetor Holder) | 20. Breather Hose (To Canister, Blue) |
| 2. To Air Vent Filter | 13. Fitting (4 Way) | 21. Breather Hose (To Fuel Tank) |
| 3. Carburetor Vent Hose | 14. Vacuum Hose (To #1 Carburetor Holder) | 22. Drain Hose |
| 4. Carburetor Vent Hoses | 15. Separator | 23. Clamp |
| 5. Fitting (3 Way) | 16. Band | 24. Air Cleaner |
| 6. Carburetor Vent Hose (To 3 Way Fitting) | 17. Purge Hose (3 Way Fitting to Canister, Green) | 25. Clamp |
| 7. Fitting | 18. Fitting (3 Way) | 26. Pickup Coil Cover |
| 8. Carburetor Vent Hose (To Canister, Yellow) | 19. Return Hose (To Fuel Tank) | 27. Clamp |
| 9. Vacuum Switch Valve | | 28. Plug |
| 10. Vacuum Hose | | 29. Clamp |
| 11. Vacuum Hose | | |

1-46 GENERAL INFORMATION

Cable, Wire, and Hose Routing

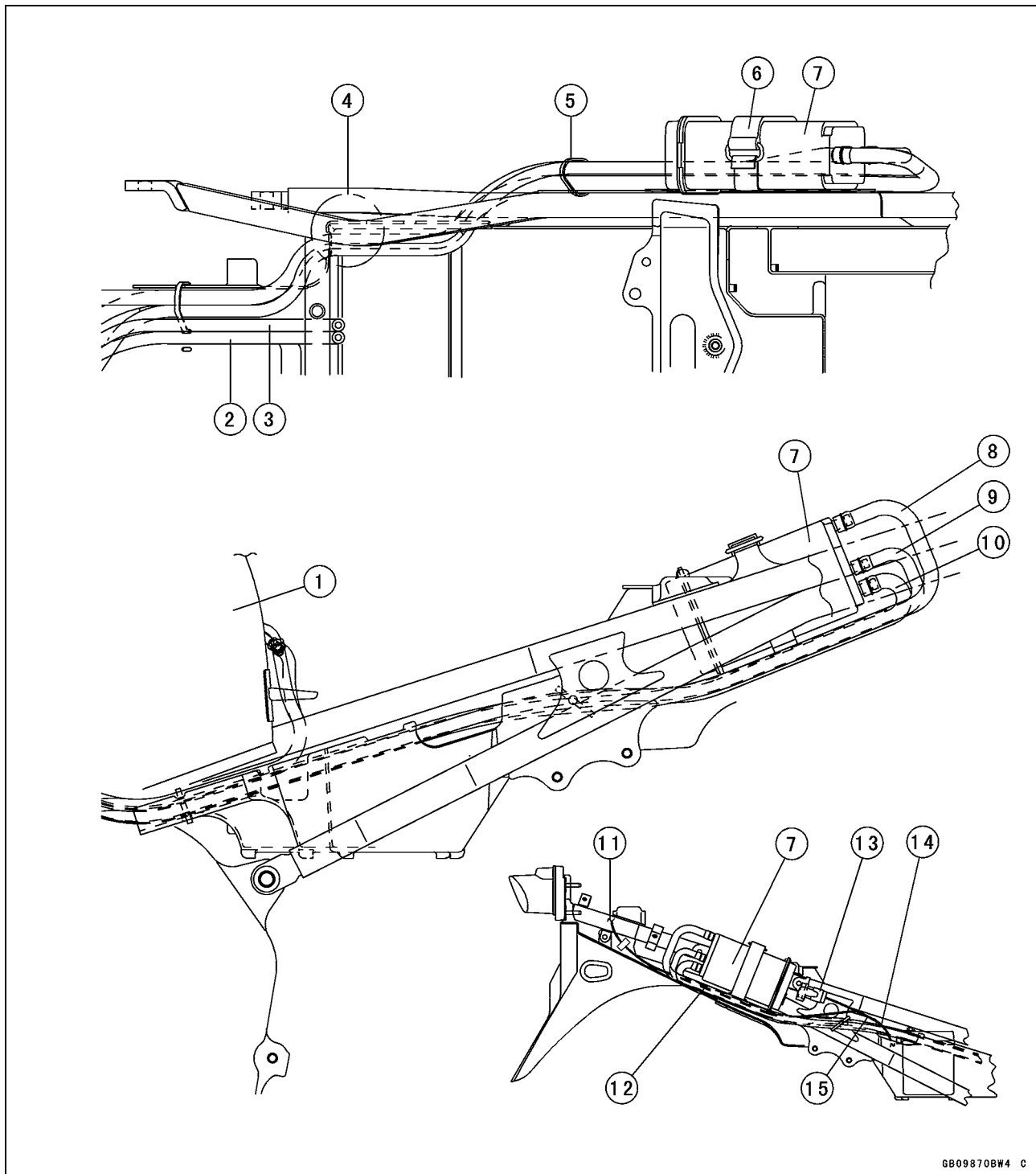

- 1. Fuel Tank
- 2. Return Hose (To Fuel Tank, Red)
- 3. Breather Hose (To Fuel Tank, Blue)
- 4. Through the cut portion of Rear Fender
- 5. Band
- 6. Band
- 7. Canister
- 8. Carburetor Vent Hose (Yellow)
- 9. Breather Hose (Blue)

- 10. Purge Hose (Green)
- 11. To Right Turn Signal Light
- 12. Canister
- 13. Headlight Fuse
- 14. Run the leads through the rear fender notch.
- 15. Run the leads over the canister hoses.
- 16. Run the turn signal lead inside of the canister hoses.

Cable, Wire and Hose Routing (ZX600-J4)

Evaporative Emission Control System (California Model)

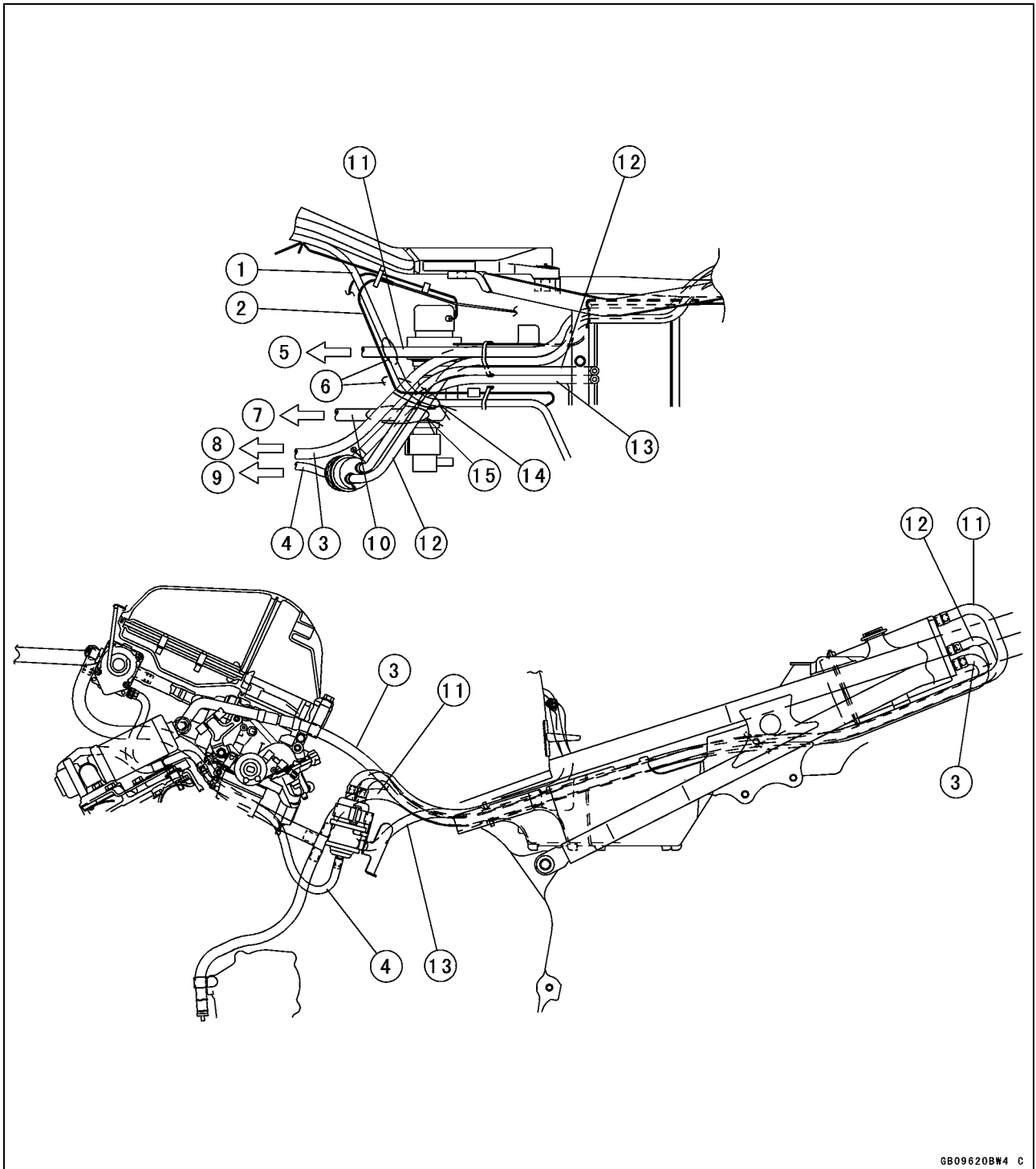

GB09620BW4 C

- | | |
|---|--|
| <ol style="list-style-type: none"> 1. Main Harness 2. Regulator/Rectifier Lead 3. Purge Hose (green) 4. Vacuum Hose (To #1 Carburetor Holder) 5. To Drain Plug 6. Run all the evaporative hoses over the main harness. 7. To Carburetor 8. To Vacuum Switch Valve 9. To #1 Carburetor Holder | <ol style="list-style-type: none"> 10. Fuel Hose 11. Carburetor Vent Hose (Yellow) 12. Breather Hose (Blue) (To Fuel Tank) 13. Return Hose (Red) (To Fuel Tank) 14. Run the red return hose under the regulator lead, and other hoses over the regulator lead. 15. Run the red return hose under the fuel hose, and other hoses over the fuel hoses. |
|---|--|

Fuel System

Table of Contents

Exploded View	2-2	Coolant Valve Inspection (Other than United States and Canada Models)	2-17
Specifications	2-5	Air Cleaner	2-18
Throttle Grip and Cables	2-6	Element Removal.....	2-18
Throttle Grip Play Inspection.....	2-6	Element Installation.....	2-18
Throttle Cable Installation	2-6	Element Cleaning and Inspection	2-18
Throttle Cable Lubrication and Inspection.....	2-6	Air Cleaner Housing Removal.....	2-19
Choke Cable.....	2-7	Air Cleaner Housing Installation..	2-19
Choke Cable Free Play Inspection.....	2-7	Air Vent Filter Cleaning	2-19
Choke Cable Free Play Adjustment	2-7	Fuel Tank	2-20
Choke Cable Installation	2-7	Fuel Tank Removal	2-20
Choke Cable Lubrication and Inspection.....	2-7	Fuel Tank Installation	2-20
Carburetors.....	2-8	Fuel Tank Inspection.....	2-21
Idle Speed Inspection	2-8	Fuel Tank Cleaning	2-21
Idle Speed Adjustment.....	2-8	Fuel Tap Removal.....	2-21
Synchronization Inspection	2-8	Fuel Tap Installation	2-22
Synchronization Adjustment	2-9	Fuel Tap Inspection.....	2-22
Service Fuel Level Inspection	2-9	Fuel Pump, Fuel Filter	2-23
Service Fuel Level Adjustment	2-10	Fuel Pump, Fuel Filter Removal ..	2-23
Fuel System Cleanliness Inspection.....	2-11	Fuel Pump, Fuel Filter Installation	2-23
Carburetor Removal.....	2-11	Fuel Pump Inspection	2-23
Carburetor Installation.....	2-12	Fuel Filter Inspection.....	2-23
Carburetor Disassembly	2-13	Evaporative Emission Control System (California Model Only).....	2-24
Carburetor Assembly	2-14	Parts Removal/Installation	2-24
Carburetor Separation	2-14	Hose Inspection	2-24
Carburetor Joining	2-14	Separator Inspection.....	2-24
Carburetor Cleaning.....	2-15	Separator Operation Test.....	2-25
Carburetor Inspection	2-15	Canister Inspection	2-25
Coolant Filter Cleaning (Other than United States and Canada Models)	2-17	Vacuum Valve Inspection.....	2-26

2-2 FUEL SYSTEM

Exploded View

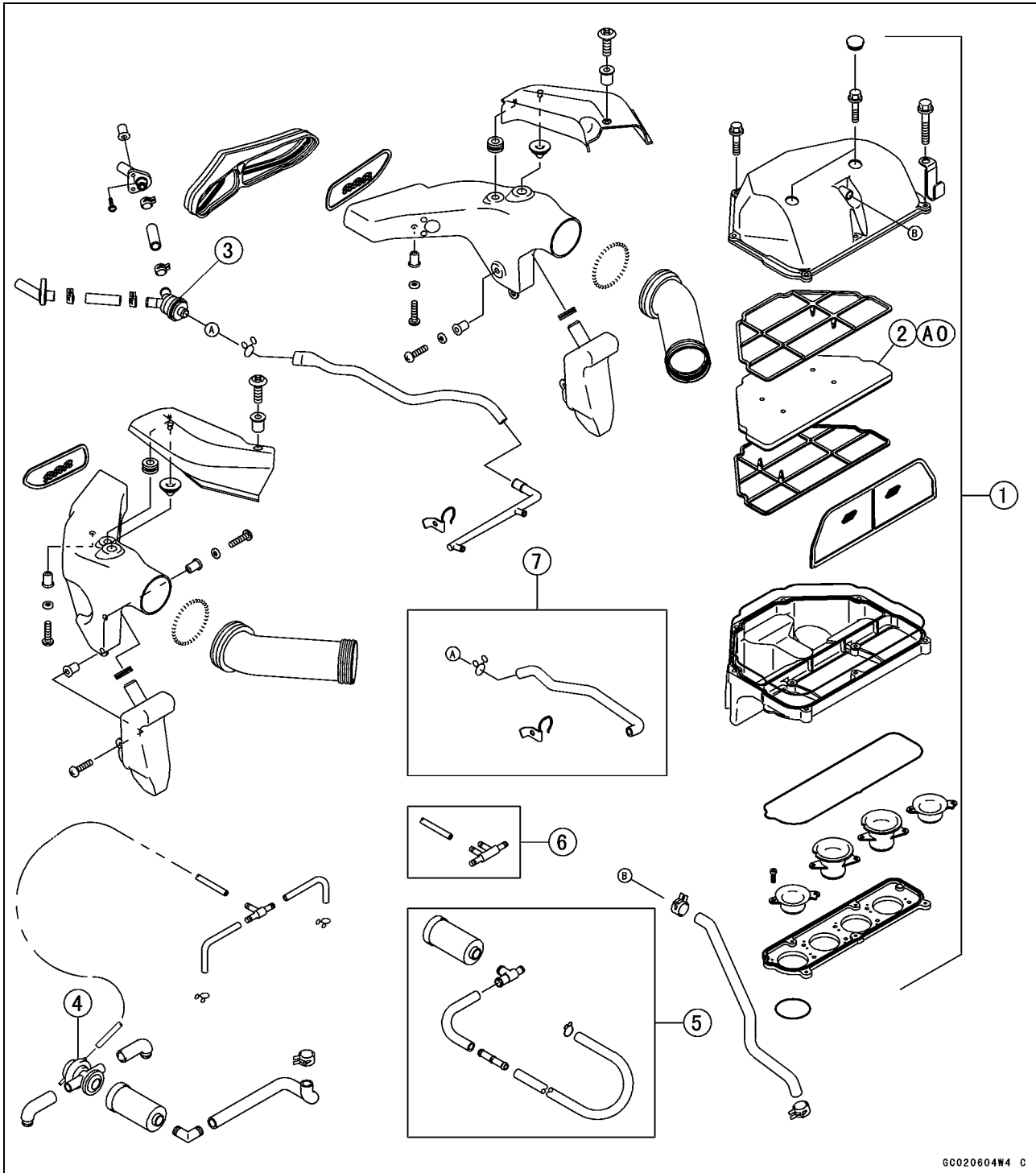

1. Air Cleaner Housing
 2. Air Cleaner Element
 3. Air Vent Filter
 4. Vacuum Switch Valve
 5. Silencer Assy (CAL Model)
 6. Vacuum Hose Assy (CAL Model)
 7. Carburetor Vent Hose (CAL Model)
- AO: Apply high quality form air filter oil.

CAL: California

Exploded View

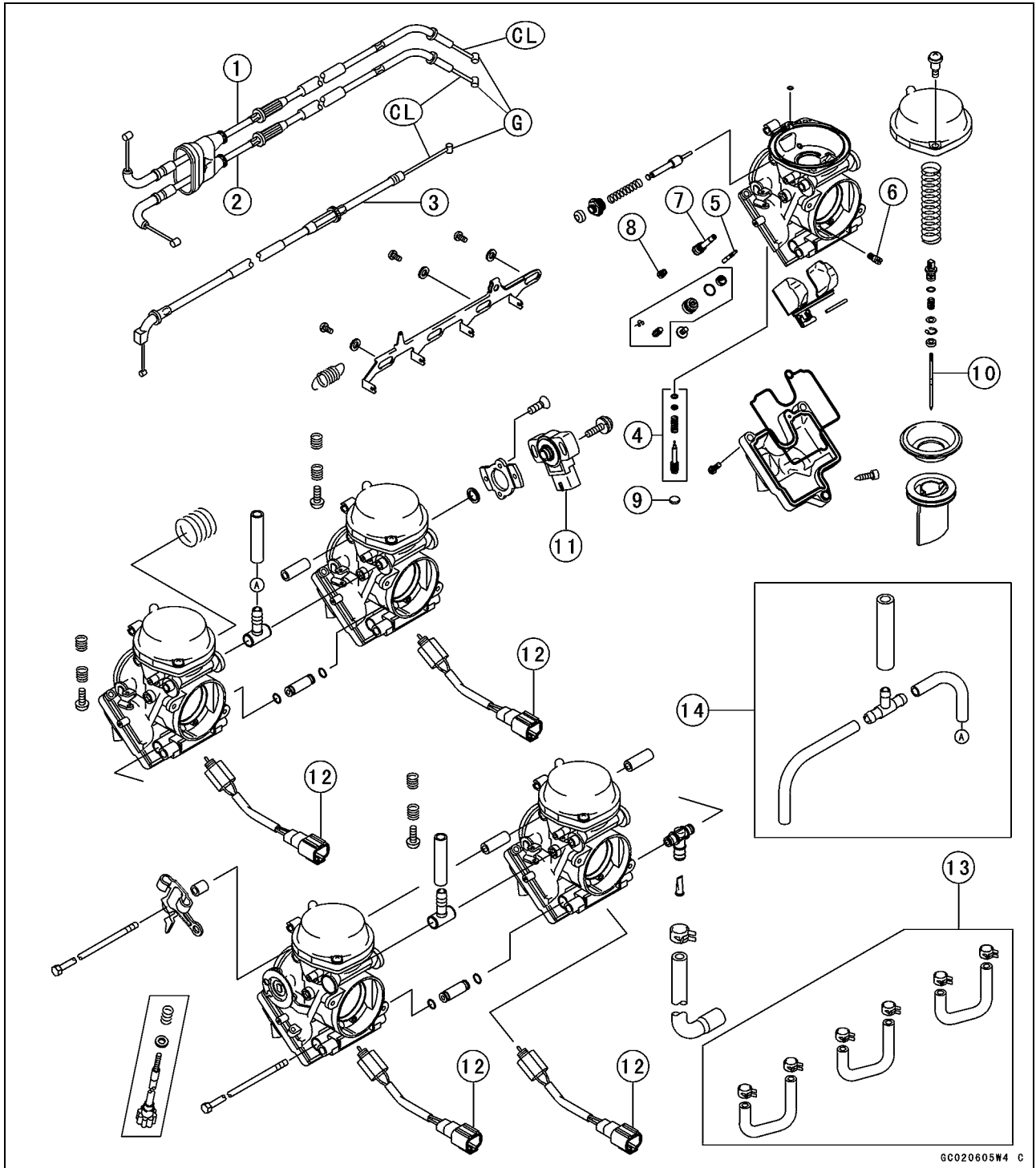

- 1. Throttle Cable (accelerator)
- 2. Throttle Cable (decelerator)
- 3. Choke Cable
- 4. Pilot Screw
- 5. Pilot (Slow) Jet
- 6. Pilot (Slow) Air Jet
- 7. Needle Jet Holder
- 8. Main Jet
- 9. Plug (US, CA Models)
- 10. Jet Needle

- 11. Throttle Sensor
 - 12. Fuel Cut Valve (CAL, H Models)
 - 13. Cooling Hose Assy (other than US, CA Models)
 - 14. Vent Hose Assy (CAL Model)
- CL: Apply cable lubricant.
 G: Apply grease.
 H: WVTA Approval Model with Honeycomb Catalytic Converter

CA: Canada
 CAL: California
 US: United States

2-4 FUEL SYSTEM

Exploded View

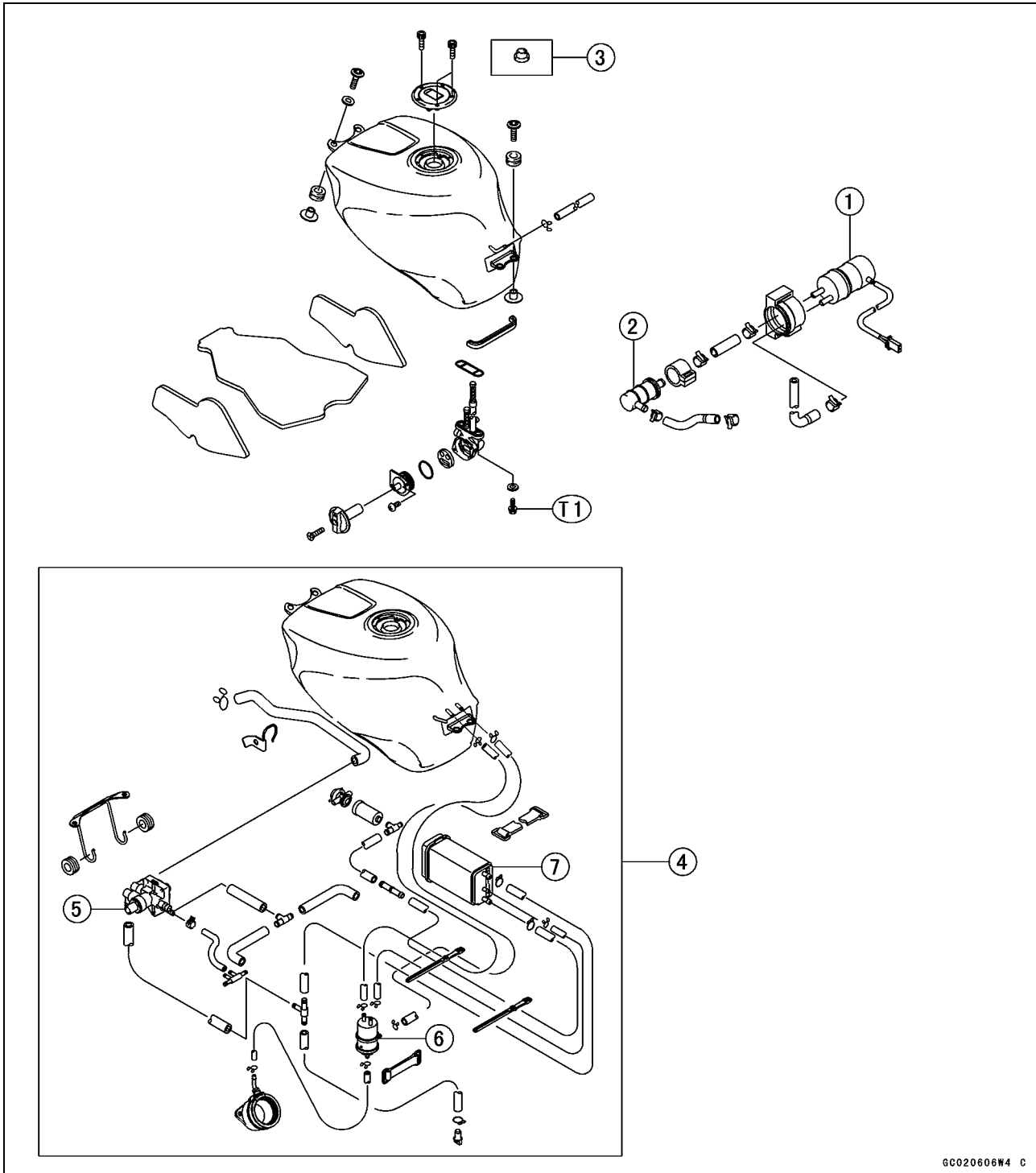

1. Fuel Pump
 2. Fuel Filter
 3. Seal (CAL Model)
 4. Evaporative Emission Control System (CAL Model)
 5. Vacuum Valve
 6. Separator
 7. Canister
- T1: 2.5 N·m (0.25 kg·m, 22 in·lb) (with white washer)
4.9 N·m (0.50 kg·m, 43 in·lb) (with black washer)

CAL: California

Specifications

Item	Standard
Throttle Grip And Cables Throttle Grip Free Play	2 ~ 3 mm (0.08 ~ 0.12 in.)
Choke Cable Free Play	2 ~ 3 mm (0.08 ~ 0.12 in.)
Carburetors Make, Type Main Jet Main Air Jet Jet Needle Pilot Jet (Slow Jet) Pilot Air Jet (Slow Air Jet) Pilot Screw (Turns Out) Starter Jet Idle Speed Carburetor Synchronization Vacuum Service Fuel Level Float Height	MIKUNI, BDSR-36 × 4 #1, 4: #155, #2, 3: #157.5 #45 5E110-54-1, (Other than US, CA) #1,4; 5E18-3, #2,3: 5E19-3 #12.5 #125 3 turns out #35 1300 ±50 r/min (rpm) Less than 2.7 kPa (2 cmHg) difference between any two carburetors 20.2 ±1 mm (0.80 ±0.04 in.) below the mark on the carburetor body 7 ±2 mm (0.28 ±0.08 in.)

CA: Canada
US: United States

- Special Tools - Carburetor Drain Plug Wrench, Hex 3: 57001-1269**
- Fuel Level Gauge: 57001-1017**
- Fork Oil Level Gauge: 57001-1290**
(as required)
- Pilot Screw Adjuster, A: 57001-1239**

2-6 FUEL SYSTEM

Throttle Grip and Cables

Throttle Grip Play Inspection

Throttle Grip Free Play Inspection

- Check the throttle grip free play [A].
- ★ If the free play is incorrect, adjust the throttle cable.

Throttle Grip Free Play

Standard: 2 ~ 3 mm (0.08 ~ 0.12 in.)

- Check that the throttle grip moves smoothly from full open to close, and the throttle closes quickly and completely in all steering positions by the return spring.
- ★ If the throttle grip does not return properly, check the throttle cable routing, grip free play, and cable damage. Then lubricate the throttle cable.
- Run the engine at the idle speed, and turn the handlebar all the way to the right and left to ensure that the idle speed does not change.
- ★ If the idle speed increase, check the throttle cable free play and the cable routing.

Throttle Grip Free Play Adjustment

- Loosen the locknuts [A], and screw both throttle cable adjusters in completely so as to give the throttle grip plenty of play.
- Turn out the decelerator cable adjuster [B] until there is no play when the throttle grip is completely closed.
- Tighten the locknut.
- ★ Turn the accelerator cable adjuster [C] until 2 ~ 3 mm (0.08 ~ 0.12 in.) of throttle grip play is obtained.
- Tighten the locknut.

Throttle Cable Installation

- Install the throttle cables in accordance with Cable, Wire, and Hose Routing section in the General Information chapter.
- Install the lower ends of the throttle cables in the cable bracket on the carburetor after installing the upper ends of the throttle cables in the grip.
- After installation, adjust each cable properly.

⚠ WARNING

Operation with incorrectly routed or improperly adjusted cables could result in an unsafe riding condition.

Throttle Cable Lubrication and Inspection

- Whenever the cables are removed, or in accordance with the Periodic Maintenance Chart, lubricate the throttle cables (see General Lubrication in the Appendix chapter).
- Apply a thin coating of grease to the cable upper ends.
- Use a commercially available pressure cable lubricator to lubricate the cables.
- With the cable disconnected at both ends, the cable should move freely in the cable housing.

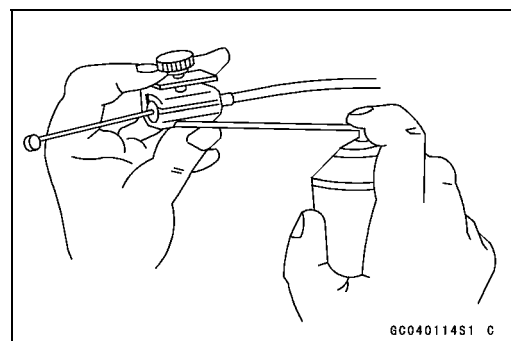
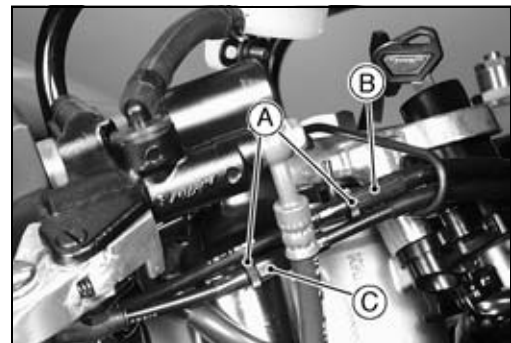
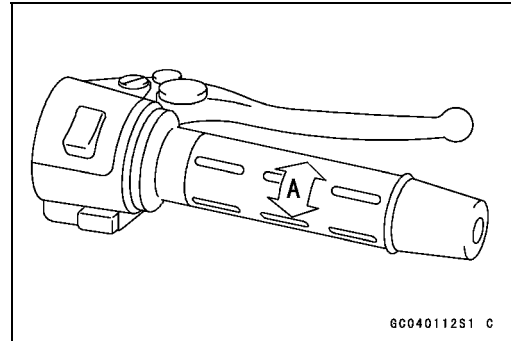

Choke Cable

Choke Cable Free Play Inspection

- Push the choke lever [A] all the way to the front.
- Check choke cable free play [B].
- Determine the amount of choke cable play at the choke lever. Pull the choke lever until the starter plunger lever [C] at the carburetor touches the starter plunger [D]; the amount of choke lever lower end travel is the amount of choke cable play.
- ★ If the free play is incorrect, adjust the choke cable.

Choke Cable Free Play

Standard: 2 ~ 3 mm (0.08 ~ 0.12 in.)

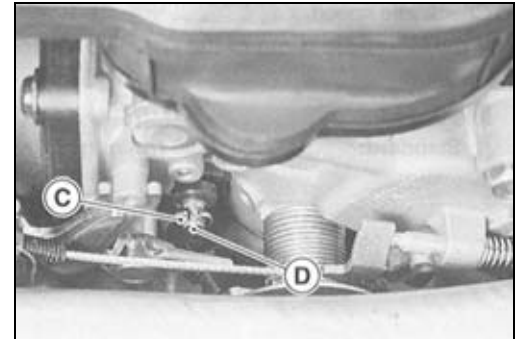
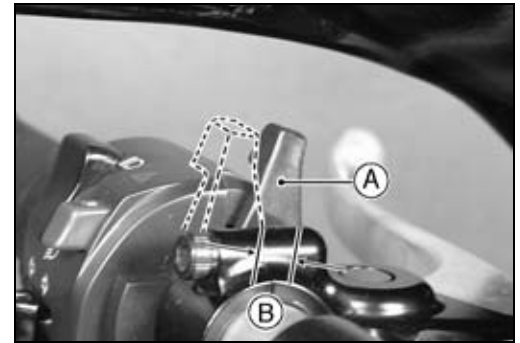

Choke Cable Free Play Adjustment

- Loosen the locknut [A], and turn the adjuster [B] until the cable has the proper amount of free play.
- Tighten the locknut securely.

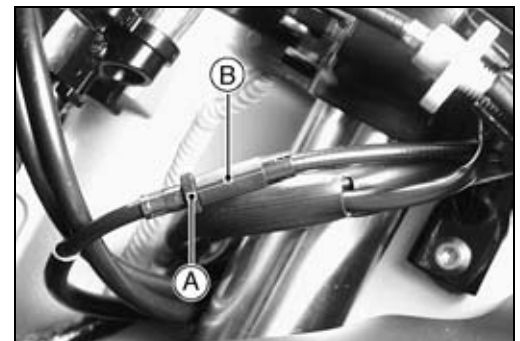

Choke Cable Installation

- Install the choke cable in accordance with the Cable, Wire, and Hose Routing section in the General Information chapter.
- After installation, adjust the cable properly.

⚠ WARNING

Operation with an incorrectly routed or improperly adjusted cable could result in an unsafe riding condition.

Choke Cable Lubrication and Inspection

- Whenever the cable is removed, or in accordance with the Periodic Maintenance Chart, lubricate the choke cable (see General Lubrication in the Appendix chapter).
- Apply a thin coating of grease to the cable upper end.
- Use a commercially available pressure cable lubricator to lubricate the cable.
- With the cable disconnected at both ends, the cable should move freely in the cable housing.

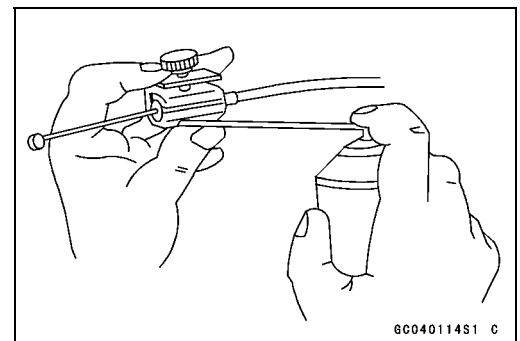

8C040114S1 C

2-8 FUEL SYSTEM

Carburetors

Idle Speed Inspection

- Start the engine and warm it up thoroughly.
- With the engine idling, turn the handlebar to both sides.
- ★ If handlebar movement changes the idle speed, the throttle cables may be improperly adjusted or incorrectly routed, or damaged. Be sure to correct any of these conditions before riding (see Cable, Wire, and Hose Routing section in the General Information chapter).

⚠ WARNING

Operation with improperly adjusted, incorrectly routed, or damaged cables could result in an unsafe riding condition.

- Check idle speed.
- ★ If the idle speed is out of the specified range, adjust it.

Idle Speed

Standard: 1 300 ±50 r/min (rpm)

Idle Speed Adjustment

- Start the engine and warm it up thoroughly.
- Turn the adjusting screw [A] until the idle speed is correct.
- Open and close the throttle a few times to make sure that the idle speed is within the specified range. Readjust if necessary.



Synchronization Inspection

- Start the engine and warm it up thoroughly.
- Check the idle speed (see Idle Speed Inspection).
- Remove the fuel tank and air cleaner housing (see Fuel Tank Removal and Air Cleaner Housing Removal).
- Supply fuel to the carburetors with an auxiliary fuel tank.
- For the models other than the California model, remove the #1, 4 carburetor vacuum hose plugs and #2, 3 carburetor vacuum hose fitting.
- Connect the suitable pipe joints [A] to the carburetor vacuum hoses [B] and vacuum gauge hoses [C].
- Install the air cleaner housing.
- Connect the vacuum gauge hoses to a vacuum gauge [A].
- Start the engine and let it idle to measure the carburetor intake vacuum.
- ★ If the vacuum is incorrect, adjust the synchronization.

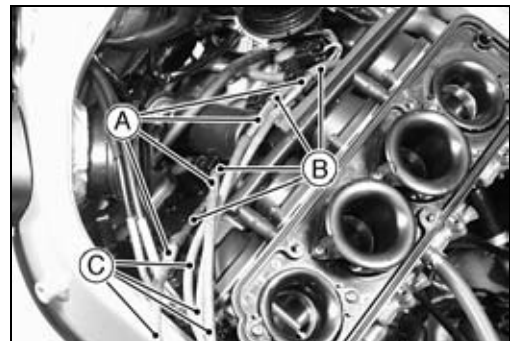

Carburetor Synchronization Vacuum

Standard: Less than 2.7 kPa (2 cmHg) difference between any two carburetors.

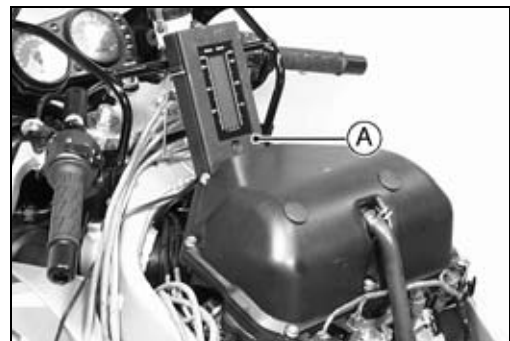

Carburetors

Synchronization Adjustment

- Turn the adjusting screw to synchronize the carburetors.
- Apply grease to the tip of the adjusting screw threads.
- First synchronize the left two and then the right two carburetors by means of the left and right adjusting screws [A, C]. Then synchronize the left two carburetors and the right two carburetors using the center adjusting screw [B].
- ★ If the carburetor synchronization cannot be obtained by using the adjusting screws, check for dirt or blockage, and then check the pilot screw settings.

Special Tool - Pilot Screw Adjuster, A: 57001-1239

- Check the carburetor synchronization again.

NOTE

○ Do not turn the pilot screws carelessly during carburetor synchronization. You may cause poor running at low engine speed.

- For the other than the California model, remove the carburetor vacuum hose plugs and carburetor vacuum hose fitting.
- Check the idle speed.

Service Fuel Level Inspection

⚠ WARNING

Gasoline is extremely flammable and can be explosive under certain conditions. Turn the ignition switch OFF. Do not smoke. Make sure the area is well-ventilated and free from any source of flame or sparks; this includes any appliance with a pilot light.

- Situate the motorcycle so that it is perpendicular to the ground.
- Remove the fuel tank (see Fuel Tank Removal).
- Prepare an auxiliary fuel tank and connect the fuel hose to the carburetors.
- Prepare a fuel hose.
- Connect the fuel level gauge [A] to the carburetor float bowl with the fuel hose.

Special Tool - Fuel Level Gauge: 57001-1017

- Hold the gauge vertically against the side of the carburetor body so that the "middle" line [B] is several millimeters higher than the mark [C] on the carburetor body.
- Feed fuel to the carburetor, then turn the carburetor drain plug [D] out a few turns.

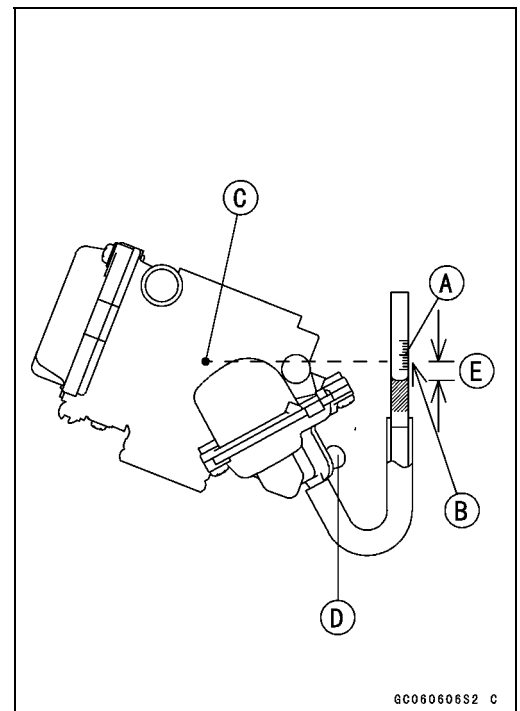
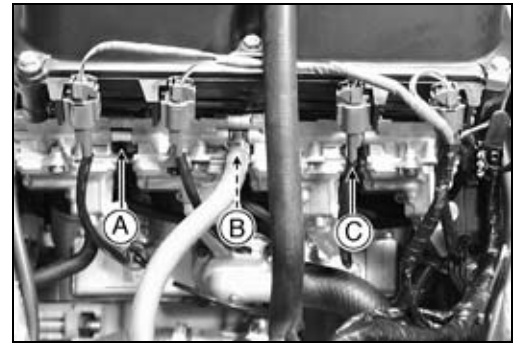

6C060606S2 C

2-10 FUEL SYSTEM

Carburetors

- Wait until the fuel level in the gauge settles.
- Keeping the gauge vertical, align the "middle" line with the mark.

NOTE

○Do not lower the "middle" line below the mark of the carburetor body. If the gauge is lowered and then raised again, the fuel level measured shows somewhat higher than the actual fuel level. If the gauge is lowered too far, dump the fuel into a suitable container and start the procedure over again.

- Read the fuel level [E] in the gauge and compare to the specification.
- Screw in the carburetor drain plug.
- Stop feeding and remove the fuel level gauge.
- ★ If the fuel level is incorrect, adjust it (see Service Fuel Level Adjustment).

Service Fuel Level (below the mark on the carburetor body)

Standard: 20.2 ±1 mm (0.80 ±0.04 in.)

Service Fuel Level Adjustment

⚠ WARNING

Gasoline is extremely flammable and can be explosive under certain conditions. Turn the ignition switch OFF. Do not smoke. Make sure the area is well-ventilated and free from any source of flame or sparks; this includes any appliance with a pilot light.

- Remove the carburetor, and drain the fuel into a suitable container.
- Remove the float bowl.
- Slide out the pivot pin [A] with a suitable tool [B], and remove the float [C] and float valve needle [D].
- Bend the tang [A] on the float arm very slightly to change the float height. Increasing the float height lowers the fuel level and decreasing the float height raises the fuel level.

Float Height

Standard: 7 ±2 mm (0.28 ±0.08 in.)

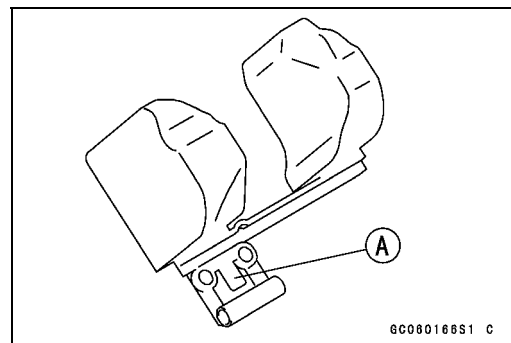
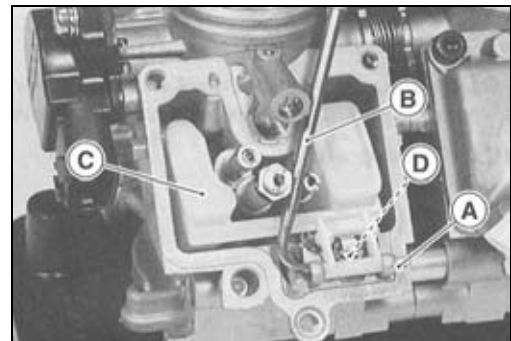
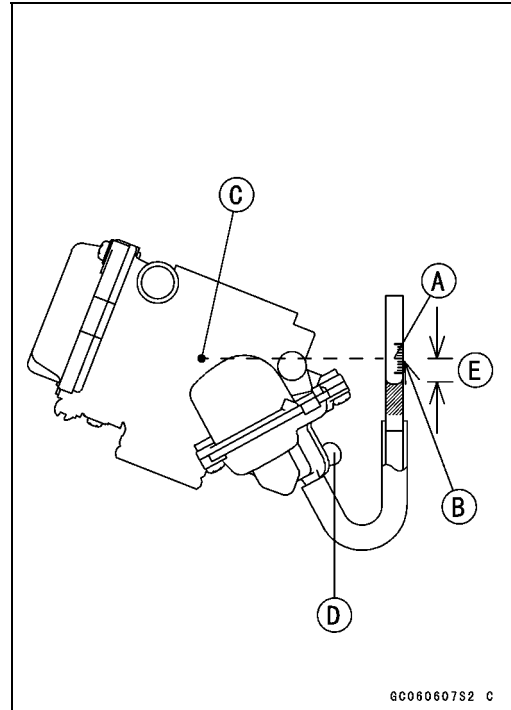

Carburetors

NOTE

○ Do not push the needle rod [A] in during the float height measurement [B].

- Assemble the carburetor, and recheck the fuel level.
- ★ If the fuel level cannot be adjusted by this method, the float or the float valve [C] is damaged.

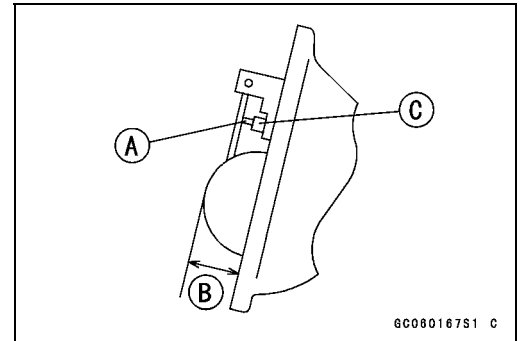

Fuel System Cleanliness Inspection

⚠ WARNING

Gasoline is extremely flammable and can be explosive under certain conditions. Turn the ignition switch OFF. Do not smoke. Make sure the area is well-ventilated and free from any source of flame or sparks; this includes any appliance with a pilot light.

- Remove the fuel tank (see Fuel Tank Removal)
- Connect a suitable hose [A] to the fitting at the bottom of each carburetor float bowl.
- Run the lower ends of the hoses into a suitable container.
- Turn out each drain plug [B] a few turns and drain the float bowls.

Special Tool - Carburetor Drain Plug Wrench, Hex 3: 57001-1269

- Check to see if water or dirt comes out.
- Tighten the drain plugs.
- ★ If any water or dirt appears during the above inspection, clean the fuel system (see Carburetor Cleaning and Fuel Tank Cleaning).

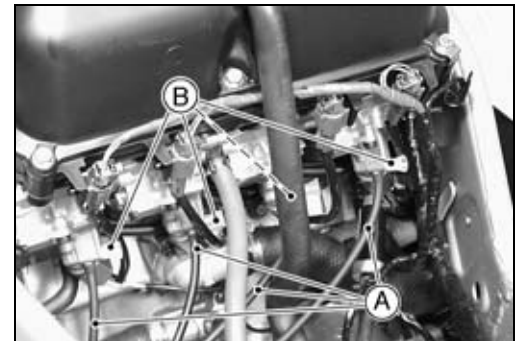

Carburetor Removal

⚠ WARNING

Gasoline is extremely flammable and can be explosive under certain conditions. Turn the ignition switch OFF. Do not smoke. Make sure the area is well-ventilated and free from any source of flame or sparks; this includes any appliance with a pilot light.

- Drain the coolant (For the other than US & CA models, see Cooling System chapter)
- Remove:
 - Seats (see Frame chapter)
 - Fuel Tank (see Fuel Tank Removal)
 - Air Cleaner Housing (see Air Cleaner Housing Removal)
 - Vent Hose
 - Fuel Hose
 - Coolant Hoses (For the other than US & CA Models)
 - Throttle Sensor Connector
 - Fuel Cut Valve Connectors (CAL and H Model)

2-12 FUEL SYSTEM

Carburetors

- Loosen the carburetor clamp screws [A], and remove the carburetors.
- Remove the throttle cable ends and choke cable.
- Stuff pieces of lint-free, clean cloth into the carburetor holders to keep dirt out of the engine.

⚠ WARNING

If dirt or dust is allowed to pass through into the carburetor, the throttle may become stuck, possibly causing an accident.

CAUTION

If dirt gets through into the engine, excessive engine wear and possibly engine damage will occur.

Carburetor Installation

- Route the cables, harness, and hoses correctly (see General Information chapter).
- Tighten the clamps for the carburetor holders at the position in the figure.

⚠ WARNING

Be sure to install the holder clamp screws in the direction shown. Or, the screws could come in contact with the throttle linkage resulting in unsafe riding condition.

- Check fuel leakage from the carburetors.

⚠ WARNING

Fuel spilled from the carburetors is hazardous.

- Adjust the following items if necessary.
 - Idle Speed
 - Carburetor Synchronization
 - Throttle Cables
 - Choke Cable

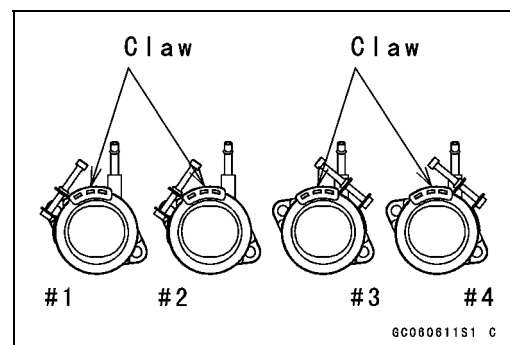

Carburetors

Carburetor Disassembly

- Remove the carburetors.

⚠ WARNING

Gasoline is extremely flammable and can be explosive under certain conditions. Turn the ignition switch OFF. Do not smoke. Make sure the area is well-ventilated and free from any source of flame or sparks; this includes any appliance with a pilot light.

NOTE

○ Carburetor can be disassembled in the joined state.

- For the US model, remove the pilot screw plug as follows: punch a hole in the plug and pry there with an awl or other suitable tool.
- Turn in the pilot screw and count the number of turns until it seats fully but not tightly, and then remove the screw. This is to set the screw to its original position when assembling.

CAUTION

During carburetor disassembly, be careful not to damage the diaphragm. Never use a sharp edge to remove the diaphragm.

- When removing the jet needle, pull straight out the holder [A] from the vacuum piston [B].

○ Remove:

- Holder [A]
- Spring [B]
- Washer [C]
- Jet Needle [D]

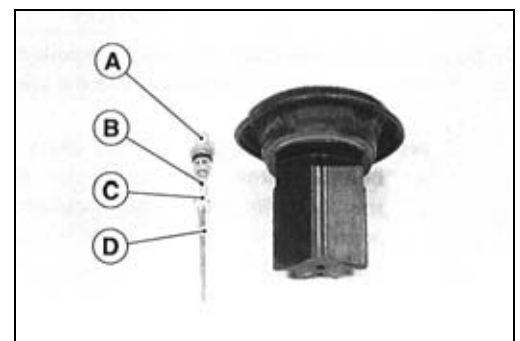
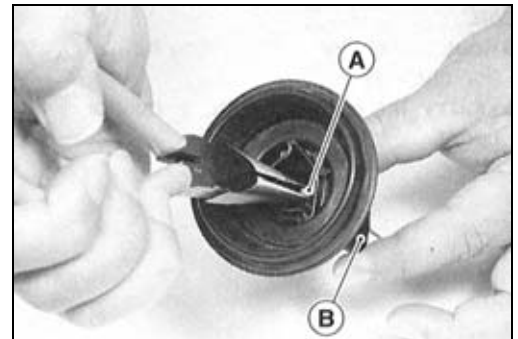

2-14 FUEL SYSTEM

Carburetors

Carburetor Assembly

- Turn in the pilot screw [A] fully but not tightly, and then back it out the same number of turns counted during disassembly.
- For the US model, install the pilot screw plug as follows: install a new plug [B] in the pilot screw hole of the carburetor body [C], and apply a small amount of a bonding agent [D] to the circumference of the plug to fix the plug.

CAUTION

Do not apply too much bonding agent to the plug or the pilot screw itself may be fixed.

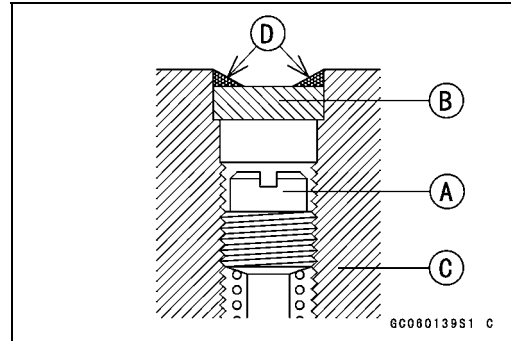

- Set the float height as specified (see Service Fuel Level Adjustment).
- After installing the upper chamber cover, check that the vacuum piston slides up and down smoothly without binding in the carburetor bore.

Carburetor Separation

- Remove the carburetor (see Carburetor Removal).
- Read the WARNING in the carburetor disassembly.
- Mark carburetor locations so that the carburetors can be installed in their original positions.

Carburetor Joining

- The center lines of the carburetor bores must be parallel both horizontally and vertically. If they are not, loosen the mounting screws and align the carburetors on a flat surface.
- Retighten the mounting screws.
- After installing the choke mechanism, check to see that the starter plunger lever slides right to left smoothly without abnormal friction.

CAUTION

Fuel mixture trouble could result if the starter plunger does not seat properly in its rest position after the choke lever is returned.

- Visually synchronize the throttle (butterfly) valves.
- Check to see that all throttle valves open and close smoothly without binding when turning the pulley.
- Visually check the clearance [A] between the throttle valve and the carburetor bore in each carburetor.
- ★ If there is a difference between any two carburetors, turn the balance adjusting screw [B] to obtain the same clearance.
- Install the carburetors (see Carburetor Installation).
- Adjust the synchronization (see Synchronization Adjustment).

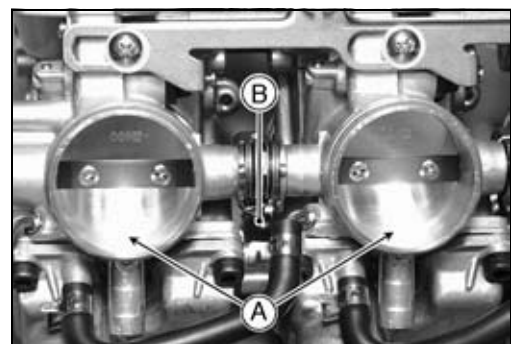

Carburetors

Carburetor Cleaning

⚠ WARNING

Clean the carburetors in a well-ventilated area, and take care that there is no sparks or flame anywhere near the working area; this includes any appliance with a pilot light. Because of the danger of highly flammable liquids, do not use gasoline or low flash-point solvents to clean the carburetors.

CAUTION

Do not use compressed air on an assembled carburetor, or the floats may be crushed by the pressure, and the vacuum piston diaphragms may be damaged.

Remove as many rubber or plastic parts from the carburetor as possible before cleaning the carburetor with a cleaning solution. This will prevent damage to or deterioration of the parts.

The carburetor body has plastic parts that cannot be removed. Do not use a strong carburetor cleaning solution which could attack these parts; instead, use a mild high flash-point cleaning solution safe for plastic parts.

Do not use wire or any other hard instrument to clean carburetor parts, especially jets, as they may be damaged.

- Disassemble the carburetor.
- Immerse all the metal parts in a carburetor cleaning solution.
- Rinse the parts in water.
- When the parts are clean, dry them with compressed air.
- Blow through the air and fuel passages with compressed air.
- Assemble the carburetor.

Carburetor Inspection

⚠ WARNING

Gasoline is extremely flammable and can be explosive under certain conditions. Turn the ignition switch OFF. Do not smoke. Make sure the area is well-ventilated and free from any source of flame or sparks; this includes any appliance with a pilot light.

- Remove the carburetors.
- Before disassembling the carburetors, check the fuel level (see Fuel Level Inspection).
- ★ If the fuel level is incorrect, inspect the rest of the carburetor before correcting it.

2-16 FUEL SYSTEM

Carburetors

- Slide the starter plunger lever to the left and release it to check that the starter plungers move smoothly and return by spring tension.
- ★ If the starter plungers do not work properly, replace the carburetors.
- Turn the throttle cable pulley to check that the throttle butterfly valves [A] move smoothly and return by spring tension.
- ★ If the throttle valves do not move smoothly, replace the carburetors.

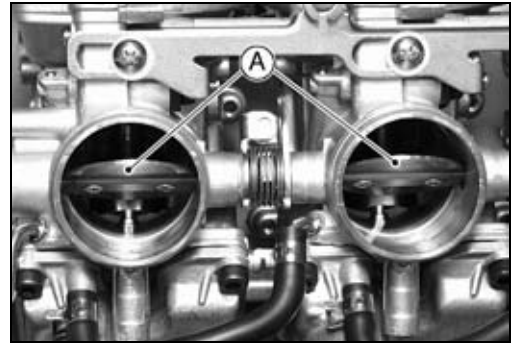

- Disassemble the carburetors.
- Clean the carburetors.
- Check that the O-rings on the float bowl and pilot screw and the diaphragm on the vacuum piston are in good condition.
- ★ If any of the O-rings or diaphragms are not in good condition, replace them.
- Check the plastic tip [A] of the float valve needle [B]. It should be smooth, without any grooves, scratches, or tears.
- ★ If the plastic tip is damaged [C], replace the needle.
- Push the rod [D] in the other end of the float valve needle, and then release it [E].
- ★ If the rod does not spring out, replace the needle.

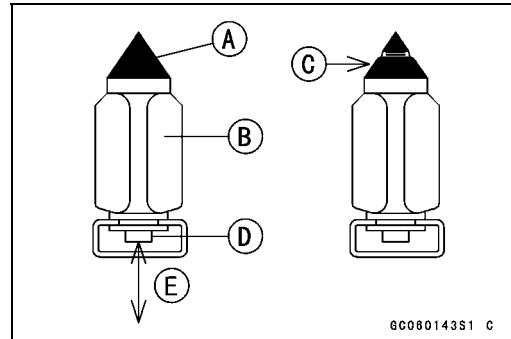

- Check the tapered portion [A] of the pilot screw [B] for wear or damage.
- ★ If the pilot screw is worn or damaged on the tapered portion, it will prevent the engine from idling smoothly. Replace it.

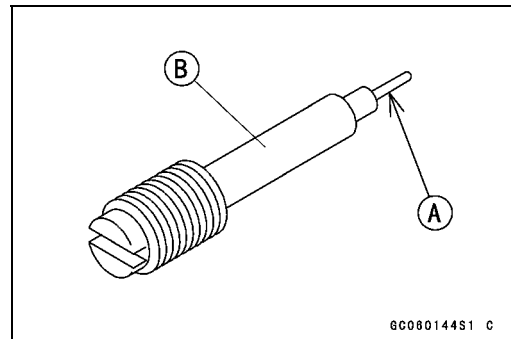

- Check that the vacuum piston [A] moves smoothly in the carburetor body. The surface of the piston must not be excessively worn.
- ★ If the vacuum piston does not move smoothly, or if it is very loose in carburetor body, replace the carburetor.

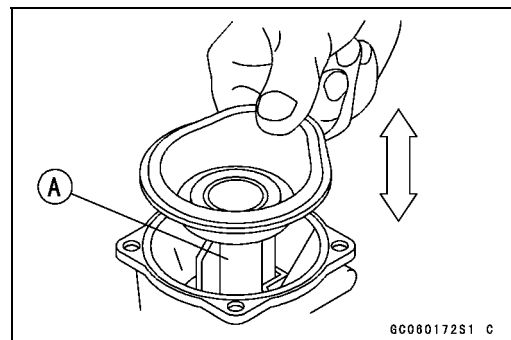

Carburetors

Coolant Filter Cleaning (Other than United States and Canada Models)

Before winter season starts, clean the filter of carburetor system.

- Remove the fuel tank (see Fuel Tank Removal).
- Drain the coolant (see Cooling System chapter).
- Remove the filter [A] from the cooling hoses [B] of carburetor system.
- Blow off dirt and sediment on the filter with compressed air.

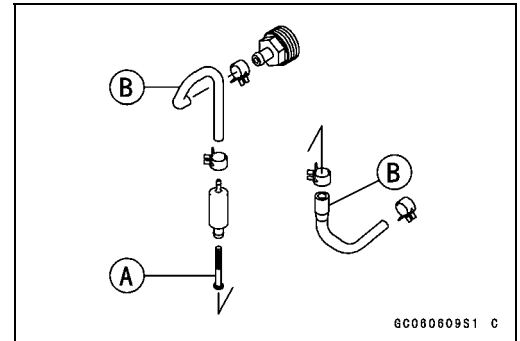

Coolant Valve Inspection (Other than United States and Canada Models)

- Drain the coolant (see Cooling System chapter).
- Remove the coolant valve on the engine left side.
- Inspect the coolant valve [A] at room temperature.
- ★ If the valve is closed, replace the valve with a new one.
- To check valve opening just blow through the valve.

Valve Closing Temperature (for reference)

Standard: 70°C (158°F) or more at 25 kPa (0.25 kg/cm², 3.6 psi)

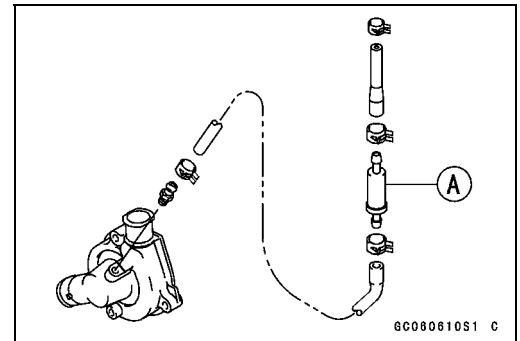

2-18 FUEL SYSTEM

Air Cleaner

Element Removal

- Remove:
 - Seats (see Frame chapter)
 - Fuel Tank (see Fuel Tank Removal)
 - Upper Housing Mounting Bolts [A]
 - Upper Housing [B]
- Remove the following parts as a unit.
 - Upper Plastic Holder [A]
 - Element [B]
 - Lower Plastic Holder [C]
- Put a clean, lint-free towel on the air cleaner housing to keep dirt or other foreign material from entering.

⚠ WARNING

If dirt or dust is allowed to pass through into the carburetors, the butterfly valves may become stuck, possibly causing an accident.

CAUTION

If dirt gets through into the engine, excessive engine wear and possibly engine damage will occur.

Element Installation

- Install the element unit [A] with the foam element side (gray) facing up.

Element Cleaning and Inspection

⚠ WARNING

Clean the element in a well-ventilated area, and make sure that there are no sparks or flame anywhere near the working area.

Because of the danger of highly flammable liquids, do not use gasoline or a low flash-point solvent to clean the element.

- Remove the air cleaner element [A] (see this chapter).
- Clean the element in a bath of high flash-point solvent, and then dry it with compressed air or by shaking it.
- After cleaning, saturate a clean, lint-free towel with SE, SF, or SG class SAE 30 oil and apply the oil to the element by tapping the element outside with the towel.
- Visually check the element for tears or breaks.
- ★ If the element has any tears or breaks, replace the element.

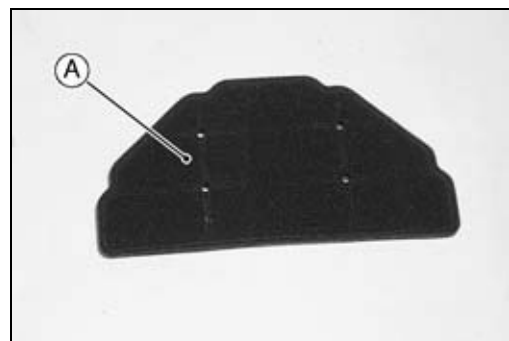
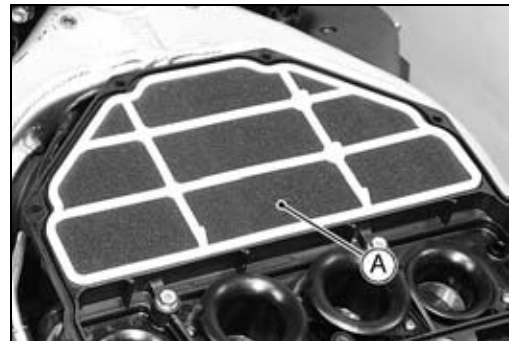
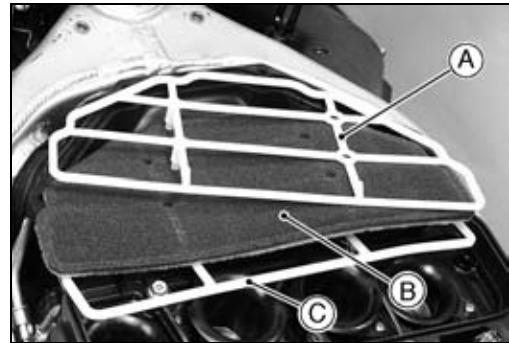
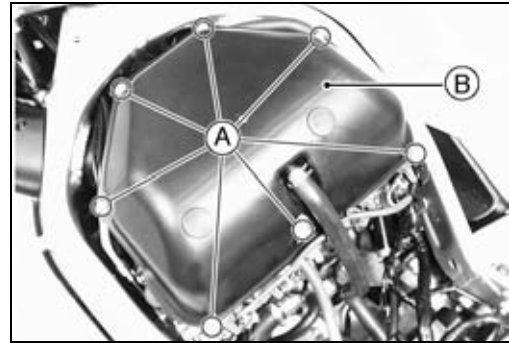

Air Cleaner

Air Cleaner Housing Removal

- Remove:
 - Seats (see Frame chapter)
 - Fuel Tank (see Fuel Tank Removal)
 - Engine Breather Hose [A]
 - Rubber Plugs [B]
 - Fuel Cut Valve Connectors [C] (California and H Models)

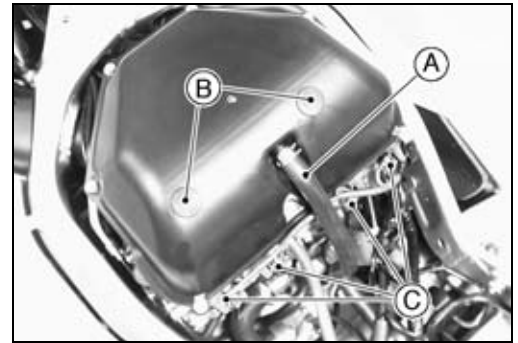

- Remove:
 - Air Cleaner Housing Mounting Bolts [A]
- Free the main harness from the clamp [B].
- Pull up the rear of the housing, and then remove it from the air ducts.

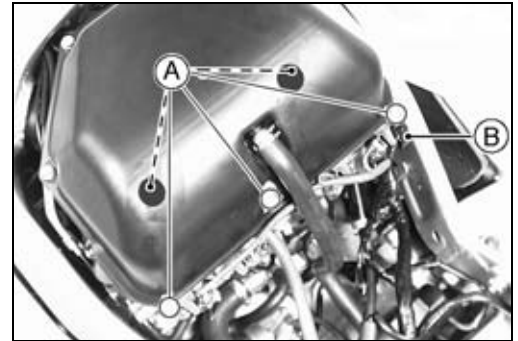

Air Cleaner Housing Installation

- Insert the housing into the air ducts [A] securely, and fit the projection [B] of the housing in the recess of the air ducts.
- Tighten:
 - Housing Mounting Bolts
- Be sure to fit the engine breather hose.
- Install the rubber plugs in place.

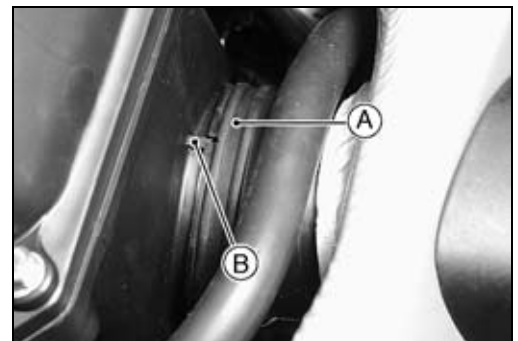

Air Vent Filter Cleaning

- Slide the clamps of air vent filter and remove the filter.
- Clean the filter by directing a stream of compressed air from clean side [A] to dirty side [B].

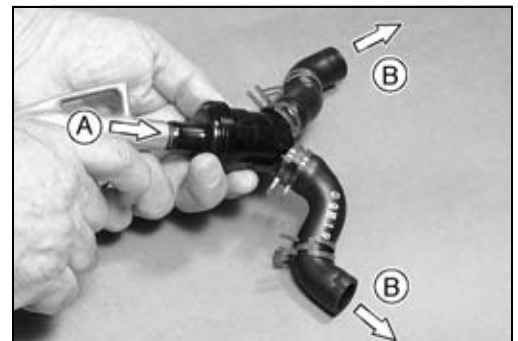

2-20 FUEL SYSTEM

Fuel Tank

Fuel Tank Removal

⚠ WARNING

Gasoline is extremely flammable and can be explosive under certain conditions. Turn the ignition switch OFF. Do not smoke. Make sure the area is well-ventilated and free from any source of flame or sparks; this includes any appliance with a pilot light.

CAUTION

For California model, if gasoline, solvent, water or any other liquid enters the canister, the canister's vapor absorbing capacity is greatly reduced. If the canister does become contaminated, replace it with a new one.

- Turn the fuel tap position lever [A] to the OFF position.
- Remove:
 - Seats (see Frame chapter)
 - Evaporative Emission Hoses (California model)
 - Fuel Filter Hose [B]
 - Fuel Tap Position Lever Screws [C]

- Remove:
 - Mounting Bolts [A]
 - Bracket [B]
- Pull the rear part of the fuel tank right side to clear the fuel tap, and then remove the fuel tank.

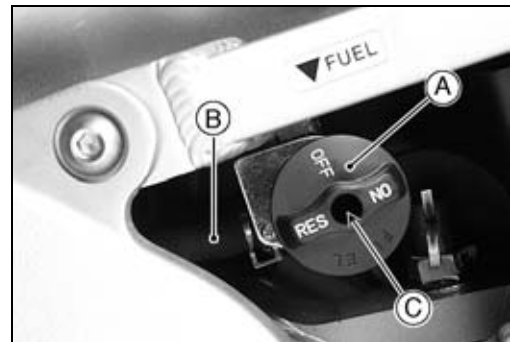

Fuel Tank Installation

- Read the WARNING mentioned in Fuel Tank removal.
- Route the hoses correctly (see General Information chapter).
- Be sure the hoses are clamped securely to prevent leaks. Check the rubber dampers.
- ★ If any damper is damaged or deteriorated, replace it.

Fuel Tank

Fuel Tank Inspection

- Remove the hose(s) from the fuel tank, and open the tank cap.
- Check to see if the water drain pipe [B] (also the breather pipe [C] for the California model) in the tank is not clogged. Check the tank cap breather also.
- ★ If they are clogged, remove the tank and drain it, and then blow the pipes free with compressed air.

CAUTION

Do not apply compressed air to the air vent holes [A] in the tank cap. This could cause damage and clogging of the labyrinth in the cap.

Fuel Tank Cleaning

⚠ WARNING

Clean the tank in a well-ventilated area, and take care that there are no sparks or flame anywhere near the working area. Because of the danger of highly flammable liquids, do not use gasoline or low flash-point solvents to clean the tank.

- Remove the fuel tank and drain it.
- Pour some high flash-point solvent into the fuel tank and shake the tank to remove dirt and fuel deposits.
- Pour high flash-point solvent through the tap in all lever positions.
- Pour the solvent out of the tank.
- Remove the fuel tap from the tank (see Fuel Tap Removal).
- Clean the fuel tap filter screens in a high flash-point solvent.
- Dry the tank and screens with compressed air.
- Install the tank filters in the tank.
- Install the fuel tank (see Fuel Tank Installation).

Fuel Tap Removal

- Remove the Fuel Tap Position Lever (see Fuel Tank Removal).
- Remove the fuel tank and drain it.
- Remove:
 - Bolts [A]
 - Flat Washers [B]
 - Fuel Tap [C]

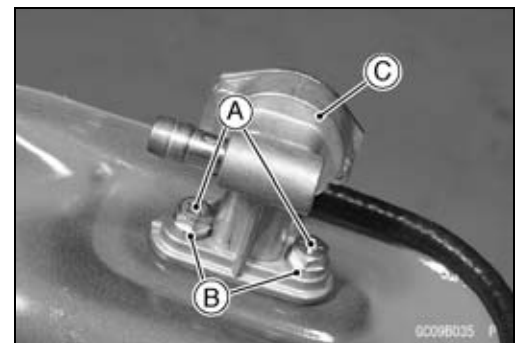
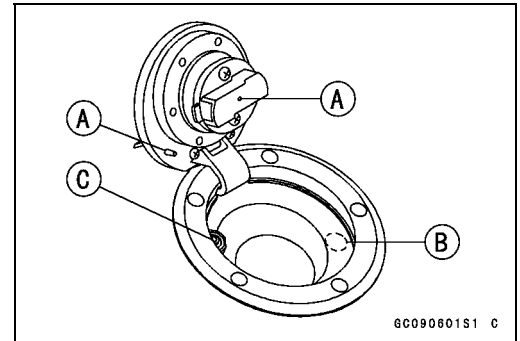

2-22 FUEL SYSTEM

Fuel Tank

Fuel Tap Installation

- Be sure the O-rings [A] is in good condition to prevent leaks.
- Be sure the flat washers [B] are in good condition to prevent leaks.
- Do not use steel washers in place of the flat washers, because they will not seal the bolts properly and fuel will leak.
- Be sure to clamp the fuel hoses to the tap to prevent leaks.

Torque - Fuel Tap Bolts (with white washer): 2.5 N·m (0.25 kg·m, 22 in·lb)

Fuel Tap Bolts (with black washer): 4.9 N·m (0.50 kg·m, 43 in·lb)

Fuel Tap Inspection

- Remove the fuel tap.
- Check the fuel tap filter screens [A] for any breaks or deterioration.
- ★ If the fuel tap screens have any breaks or are deteriorated, they may allow dirt to reach the carburetor, causing poor running. Replace the fuel tap.
- ★ If the fuel tap leaks, or allows fuel to flow when it is at OFF position, replace the damaged gasket [B] or O-ring [C].

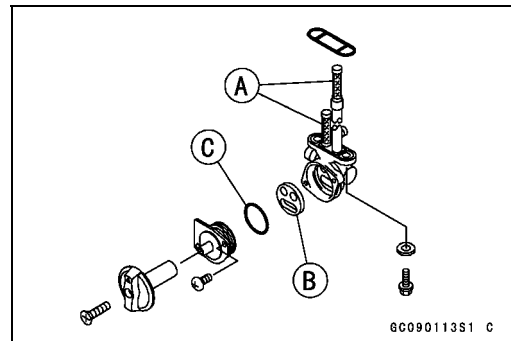
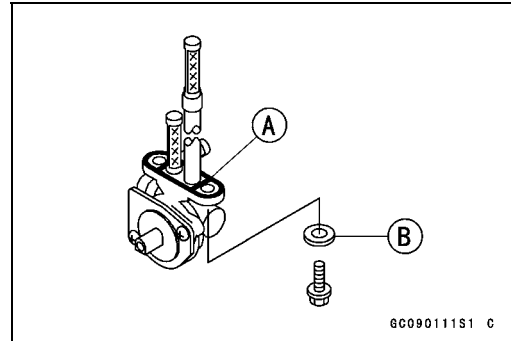

Fuel Pump, Fuel Filter

Fuel Pump, Fuel Filter Removal

⚠ WARNING

Gasoline is extremely flammable and can be explosive under certain conditions. Turn the ignition switch OFF. Do not smoke. Make sure the area is well-ventilated and free from any source of flame or sparks; this includes any appliance with a pilot light.

- Remove:
 - Seats (see Frame chapter)
 - Fuel Tank (see Fuel Tank Removal)
 - Fuel Hose [A]
 - Fuel Pump Lead Connector [B]
- Remove the fuel pump [C] and fuel filter [D].

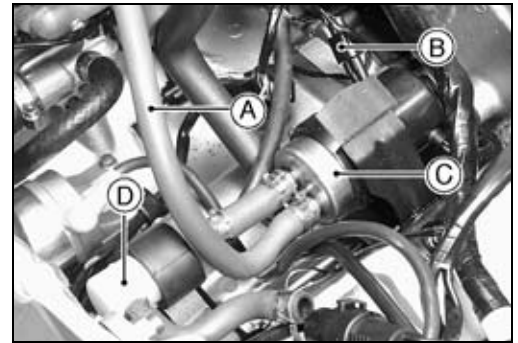

Fuel Pump, Fuel Filter Installation

- Install the fuel filter so that the arrow [A] on it shows the fuel flow from the fuel tank to the fuel pump.
- Connect the fuel hose [C] from the fuel filter to the pump fitting marked "INLET" [B].
- Be sure to route the hoses so that they will not be kinked or stretched.

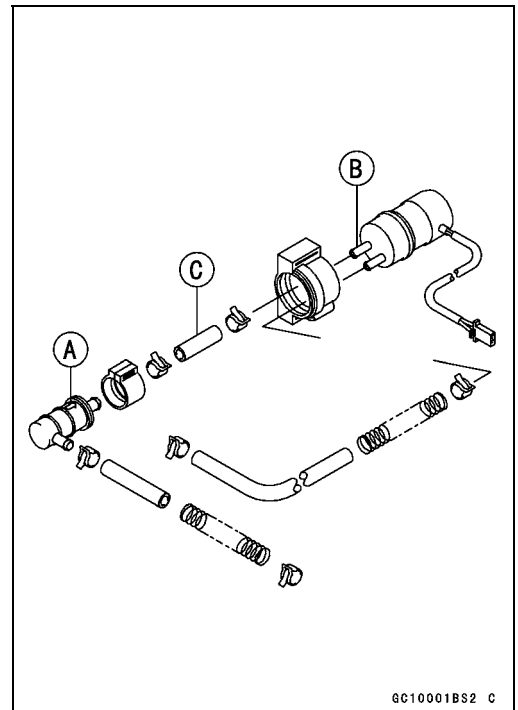

6G10001BS2 C

Fuel Pump Inspection

- Refer to the Electrical System chapter.

Fuel Filter Inspection

- Remove:
 - Seats (see Frame chapter)
 - Fuel Tank (see Fuel Tank Removal)
 - Band
- Visually inspect the fuel filter.
 - ★ If the filter is clear with no signs of dirt or other contamination, it is not necessary to replace it.
 - ★ If the filter is dark or looks dirty, replace it. Also, check the rest of the fuel system for contamination.

2-24 FUEL SYSTEM

Evaporative Emission Control System (California Model Only)

The Evaporative Emission Control System routes fuel vapors from the fuel system into the running engine or stores the vapors in a canister when the engine is stopped. Although no adjustments are required, a thorough visual inspection must be made at the intervals specified by the Periodic Maintenance Chart.

Parts Removal/Installation

⚠ WARNING

Gasoline is extremely flammable and can be explosive under certain conditions. Turn the ignition switch OFF. Do not smoke. Make sure the area is well-ventilated and free from any source of flame or sparks; this includes any appliance with a pilot light.

CAUTION

If gasoline, solvent, water or any other liquid enters the canister, the canister's vapor absorbing capacity is greatly reduced. If the canister does become contaminated, replace it with a new one.

- To prevent the gasoline from flowing into or out of the canister, hold the separator perpendicular to the ground.
- Connect the hoses according to the diagram of the system. Make sure they do not get pinched or kinked.
- Route hoses with a minimum of bending so that the air or vapor will not be obstructed.
- Be sure to plug the return hose to prevent fuel spilling before fuel tank removal.

⚠ WARNING

When removing the fuel tank, be careful not to spill the gasoline through the return hose. Spilled fuel is hazardous.

- ★ If liquid gasoline flows into the breather hose, remove the hose and blow it clean with compressed air.

Hose Inspection

- Check that the hoses are securely connected.
- Replace any kinked, deteriorated or damaged hoses.

Separator Inspection

- Remove the seats (see Frame chapter).
- Disconnect the hoses from the liquid/vapor separator, and remove the separator from the motorcycle.
- Visually inspect the separator for cracks and other damage.
- ★ If the separator has any cracks or is badly damaged, replace it with a new one.

Evaporative Emission Control System (California Model Only)

Separator Operation Test

⚠ WARNING

Gasoline is extremely flammable and can be explosive under certain conditions. Turn the ignition switch OFF. Do not smoke. Make sure the area is well-ventilated and free from any source of flame or sparks; this includes any appliance with a pilot light.

- Connect the hoses to the separator, and install the separator on the motorcycle.

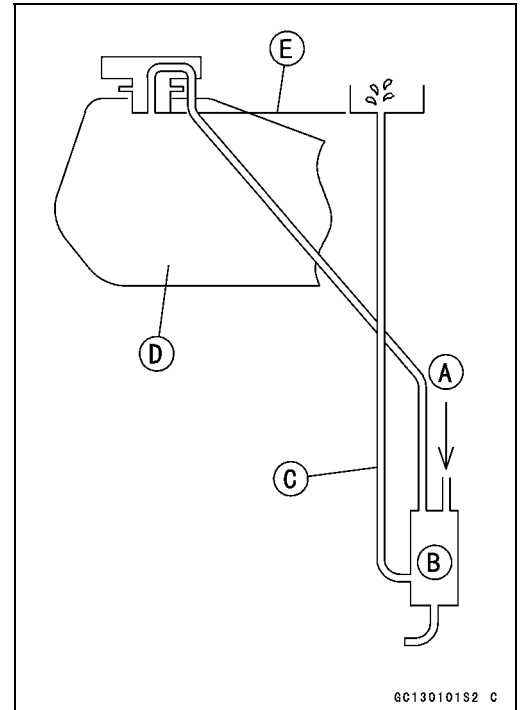

- Disconnect the breather hose from the separator, and inject about 20 mL of gasoline [A] into the separator [B] through the hose fitting.
- Disconnect the fuel return hose [C] from the fuel tank [D].
- Place the open end of the return hose into the container and hold it with the same level of the tank top [E].
- Start the engine, and let it idle.
- ★ If the gasoline in the separator comes out of the hose, the separator works well. If it does not, replace the separator with a new one.

Canister Inspection

- Remove the seats and seat cover (see Frame chapter).
- Remove the canister, and disconnect the hoses from the canister.
- Visually inspect the canister for cracks and other damage.
- ★ If the canister has any cracks or bad damage, replace it with a new one.

NOTE

○ The canister is designed to work well through the motorcycle's life without any maintenance if it is used under normal conditions.

2-26 FUEL SYSTEM

Evaporative Emission Control System (California Model Only)

Vacuum Valve Inspection

- Remove:
 - Air Cleaner Housing (see Air Cleaner Housing Removal)
 - Bracket [A] and Vacuum Valve [B]
 - Vacuum Valve Hoses [C]

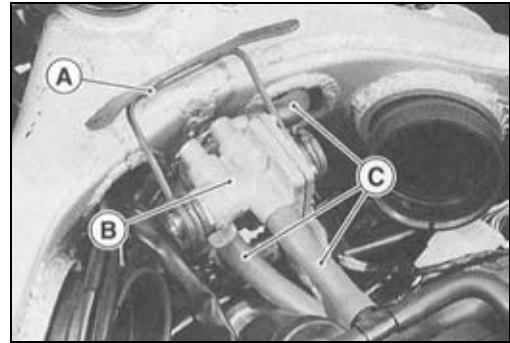

- Remove the drain screw [A] from the bottom of the chamber.

★ If any liquid accumulates in the chamber, drain it.

⚠ WARNING

The liquid may contain gasoline.

- Replace the O-ring [B] with a new one.
- After draining, install the drain screw with the O-ring.

Torque - Vacuum Valve Drain Screw: 1.0 N·m (0.10 kg·m, 9 in·lb)

- Using a vacuum gauge and fork oil level gauge, inspect the vacuum valve operation (see Vacuum Switch Valve Test in Engine Top End chapter).

Special Tool - Fork Oil Level Gauge: 57001-1290

○ When applying vacuum (1.5 cmHg) to the vacuum sensing fitting [A], air flows from pipe [B] to pipe [C], and vice versa.

○ When stopping applying vacuum, air flows from pipe [B] to pipe [D], and vice versa.

★ If the vacuum valve does not operate as described, replace it with a new one.

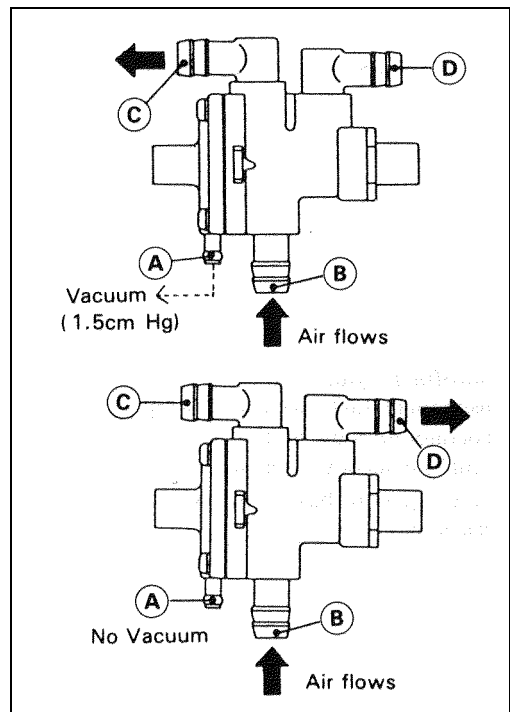
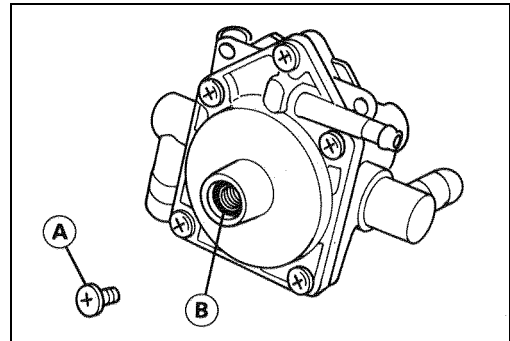

CAUTION

Do not use compressed air during the valve check, or the vacuum valve may be damaged.

Cooling System

Table of Contents

Exploded View	3-2
Specifications	3-3
Coolant Flow Chart.....	3-4
Coolant	3-6
Coolant Deterioration Inspection.....	3-6
Coolant Level Inspection.....	3-6
Coolant Draining	3-6
Coolant Filling	3-7
Pressure Testing	3-8
Cooling System Flushing	3-9
Coolant Filter Cleaning	3-9
Water Pump.....	3-10
Water Pump Removal	3-10
Water Pump Installation.....	3-10
Water Pump Inspection.....	3-10
Radiator, Radiator Fan	3-11
Radiator and Radiator Fan Removal	3-11
Radiator Inspection	3-12
Radiator Cap Inspection	3-12
Thermostat	3-13
Thermostat Removal.....	3-13
Thermostat Installation.....	3-13
Thermostat Inspection	3-13
Hose and Pipes	3-14
Hose Installation	3-14
Hose Inspection	3-14
Radiator Fan Switch, Water Temperature Sensor	3-15
Radiator Fan Switch, Water Temperature Sensor Removal	3-15
Radiator Fan Switch, Water Temperature Sensor Installation	3-15
Radiator Fan Switch, Water Temperature Sensor Inspection	3-15

3-2 COOLING SYSTEM

Exploded View

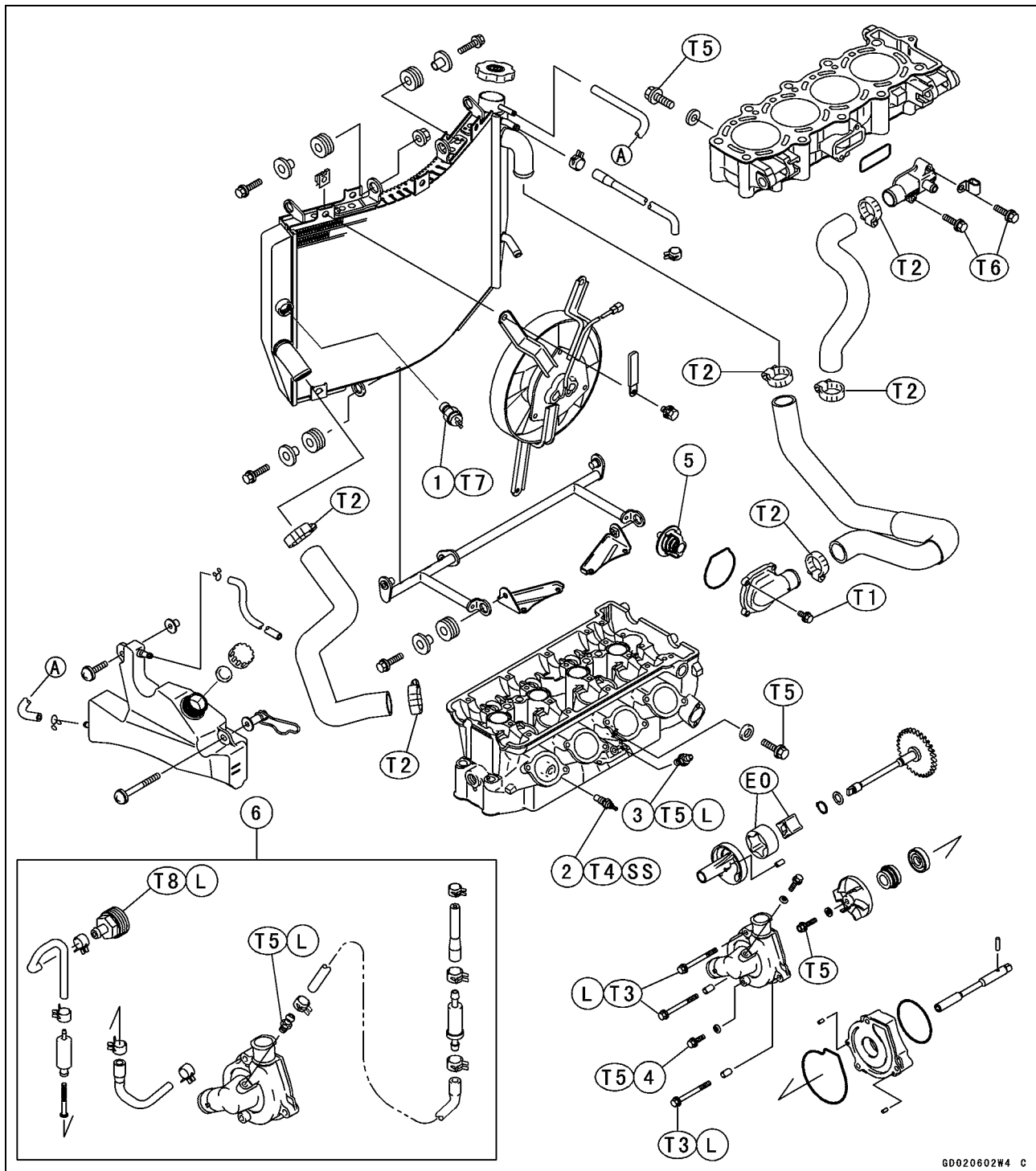

GD020602W4 C

- 1. Radiator Fan Switch
- 2. Water Temperature Sensor
- 3. Coolant By-pass Fitting
- 4. Drain Plug
- 5. Thermostat
- 6. Cooling Hose Assy (other than US, CA Models)

- T1: 5.9 N·m (0.60 kgf·m, 52 in·lb)
- T2: 2.0 N·m (0.20 kgf·m, 17 in·lb)

- T3: 12 N·m (1.2 kgf·m, 104 in·lb)
- T4: 7.8 N·m (0.80 kgf·m, 69 in·lb)
- T5: 9.8 N·m (1.0 kgf·m, 87 in·lb)
- T6: 11 N·m (1.1 kgf·m, 95 in·lb)
- T7: 18 N·m (1.8 kgf·m, 13 ft·lb)
- T8: 20 N·m (2.0 kgf·m, 14.5 ft·lb)
- E0: Apply engine oil.
- L: Apply a non-permanent locking agent.
- SS: Apply silicone sealant.

CA: Canada
 US: United States

Specifications

Item	Standard
Coolant provided when shipping Type Color Mixed ratio Freezing point Total amount	Permanent type of antifreeze (soft water and ethylene glycol plus corrosion and rust inhibitor chemicals for aluminum engines and radiators) Green Soft water 50%, coolant 50% -35°C (-31°F) 2.3 L (2.43 US qt) (reserve tank full level including radiator and engine)
Radiator cap Relief pressure:	93 ~ 123 kPa (0.95 ~ 1.25 kgf/cm ² , 14 ~ 18 psi)
Thermostat Valve opening temperature Valve full opening lift	58 ~ 62°C (136 ~ 144°F) 8 mm (0.32 in.) or more @75°C (167°F)

Sealant - Kawasaki Bond (Silicone Sealant): 56019-120

3-4 COOLING SYSTEM

Coolant Flow Chart

Permanent type antifreeze is used as a coolant to protect the cooling system from rust and corrosion. When the engine starts, the water pump turns and the coolant circulates.

The thermostat is a wax pellet type which opens or closes with coolant temperature changes. The thermostat continuously changes its valve opening to keep the coolant temperature at the proper level. When coolant temperature is below 55°C (131°F), the thermostat closes so that the coolant flow is restricted through the air bleeder hole, causing the engine to warm up more quickly. When coolant temperature is 58 ~ 62°C (136 ~ 144°F), the thermostat opens and the coolant flows.

When the coolant temperature goes up beyond 96 ~ 100°C (205 ~ 212°F), the radiator fan switch conducts to operate the radiator fan. The radiator fan draws air through the radiator core when there is not sufficient air flow such as at low speeds. This increases up the cooling action of the radiator. When the temperature is below 91°C (196°F), the fan switch opens and the radiator fan stops.

In this way, this system controls the engine temperature within narrow limits where the engine operates most efficiently even if the engine load varies.

The system is pressurized by the radiator cap to suppress boiling and the resultant air bubbles which can cause engine overheating. As the engine warms up, the coolant in the radiator and the water jacket expands. The excess coolant flows through the radiator cap and hose to the reserve tank to be stored there temporarily. Conversely, as the engine cools down, the coolant in the radiator and the water jacket contracts, and the stored coolant flows back to the radiator from the reserve tank.

The radiator cap has two valves. One is a pressure valve which holds the pressure in the system when the engine is running. When the pressure exceeds 93 ~ 123 kPa (0.95 ~ 1.25 kgf/m², 14 ~ 18 psi) the pressure valve opens and releases the pressure to the reserve tank. As soon as pressure escapes, the valve closes, and keeps the pressure at 93 ~ 123 kPa (0.95 ~ 1.25 kgf/m², 14 ~ 18 psi). When the engine cools down, another small valve (vacuum valve) in the cap opens. As the coolant cools, the coolant contracts to form a vacuum in the system. The vacuum valve opens and allows the coolant from the reserve tank to enter the radiator.

Coolant Flow Chart

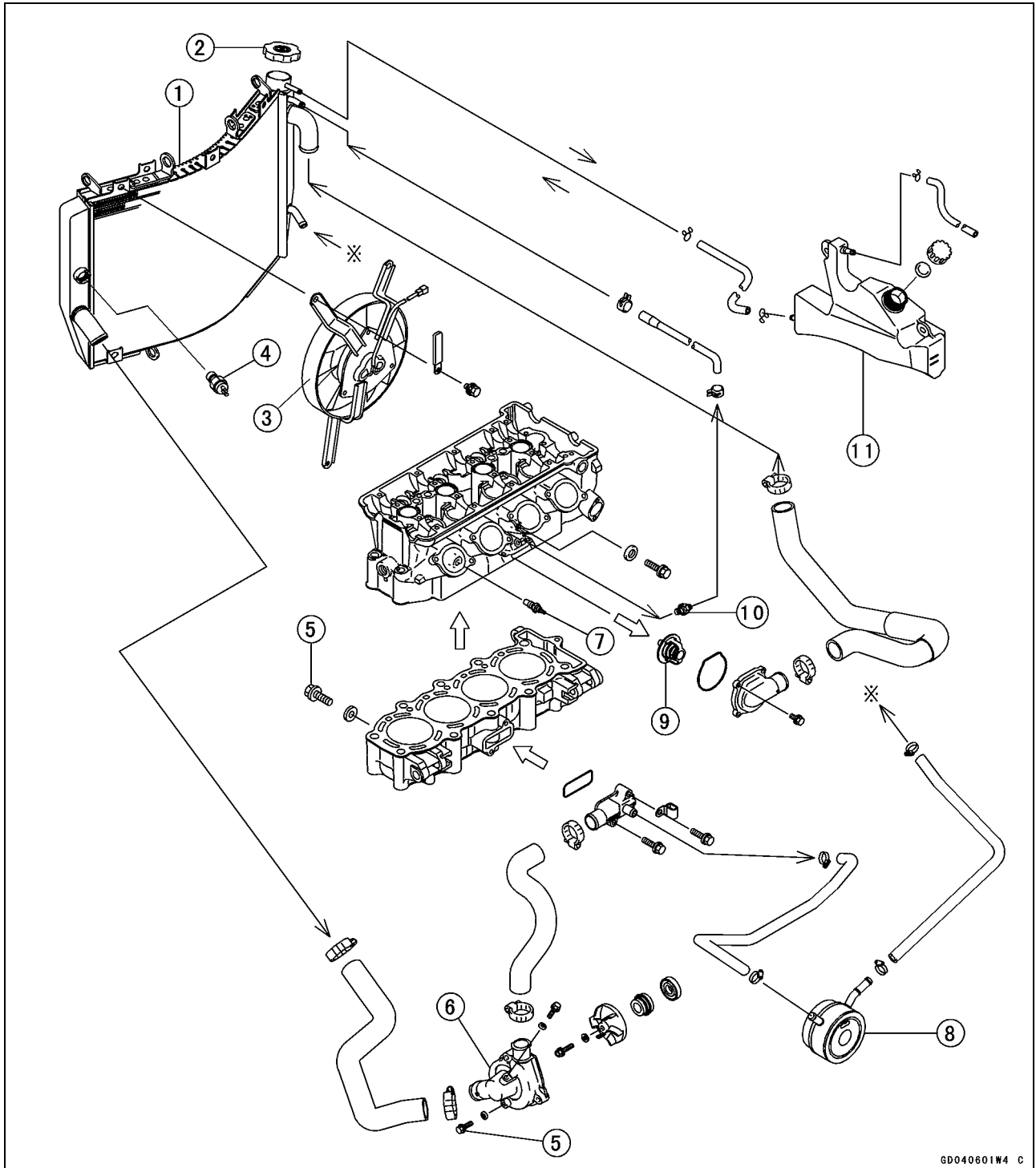

- | | |
|---|--|
| <ul style="list-style-type: none"> 1. Radiator 2. Radiator Cap 3. Radiator Fan 4. Fan Switch 9. Thermostat | <ul style="list-style-type: none"> 5. Drain Plug 6. Water Pump 7. Water Temperature Sensor 8. Oil Cooler |
|---|--|
10. By-pass Fitting
The fitting is installed to bleed the air.
11. Reserver Tank
When the engine is very hot, the pressure valve in the radiator cap allows air and vapor to escape into the reserve tank. When the engine cools down, the pressure drop draws the vacuum valve (another small valve) open, admitting coolant from the reserve tank into the radiator.

3-6 COOLING SYSTEM

Coolant

Coolant Deterioration Inspection

- Visually inspect the coolant in the reserve tank.
- ★ If whitish cotton-like wafts are observed, aluminum parts in the cooling system are corroded. If the coolant is brown, iron or steel parts are rusting. In either case, flush the cooling system.
- ★ If the coolant gives off an abnormal smell, check for a cooling system leak. It may be caused by exhaust gas leaking into the cooling system.

Coolant Level Inspection

NOTE

○ Check the level when the engine is cold (room or ambient temperature).

- Check the coolant level in the reserve tank with the motorcycle held perpendicular.
- ★ If the coolant level is lower than the low level line [A], add coolant to the full level line [B].

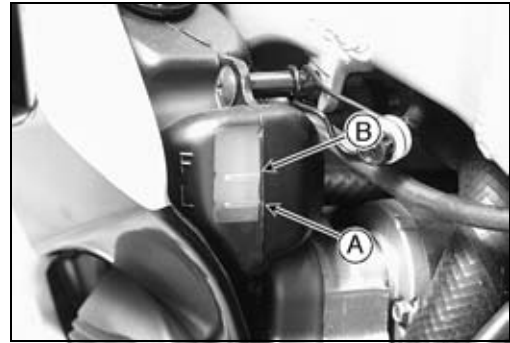

CAUTION

For refilling, add the specified mixture of coolant and soft water. Adding water alone dilutes the coolant and degrades its anticorrosion properties. The diluted coolant can attack the aluminum engine parts. In an emergency, soft water alone can be added. But the diluted coolant must be returned to the correct mixture ratio within a few days. If coolant must be added often, or the reservoir tank has run completely dry, there is probably leakage in the cooling system. Check the system for leaks.

Coolant Draining

⚠ WARNING

To avoid burns, do not remove the radiator cap or try to change the coolant when the engine is still hot. Wait until it cools down. Coolant on tires will make them slippery and can cause an accident and injury. Immediately wipe up or wash away any coolant that spills on the frame, engine, or other painted parts. Since coolant is harmful to the human body, do not use for drinking.

Coolant

- Remove:
Lower Fairing (see Frame chapter)
Radiator Cap [A]

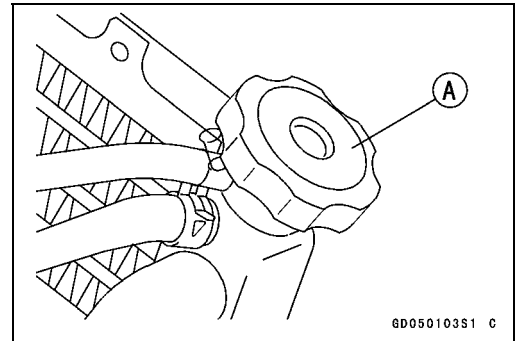

- Place a container under the drain plug [A] at the bottom of the water pump cover [B].
- Drain the coolant from the radiator and engine by removing the drain plug.

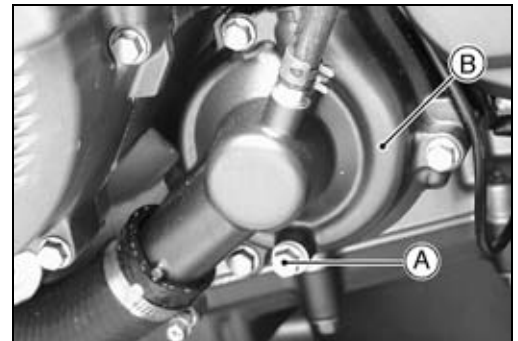

- Remove:
Lower Fairing (see Frame chapter)
Hose [A]
Mounting Screws [B] and Reserve Tank [C]
Collar and Idle Speed Adjusting Screw Bracket [D]
- Remove the cap [E] and pour the coolant into a container.

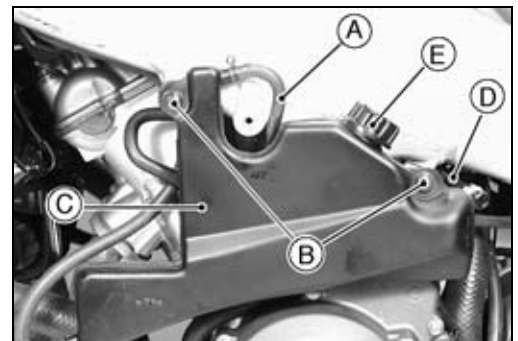

Coolant Filling

- Remove:
Lower Fairing (see Frame chapter)
- Tighten the drain plug.
Torque - Drain Plug: 9.8 N·m (1.0 kgf·m, 87 in·lb)
- Fill the radiator up to the radiator filler neck [A] with coolant, and install the radiator cap.

NOTE

○Pour in the coolant slowly so that it can expel the air from the engine and radiator.

- Fill the reserve tank up to the full level line with coolant, and install the cap.

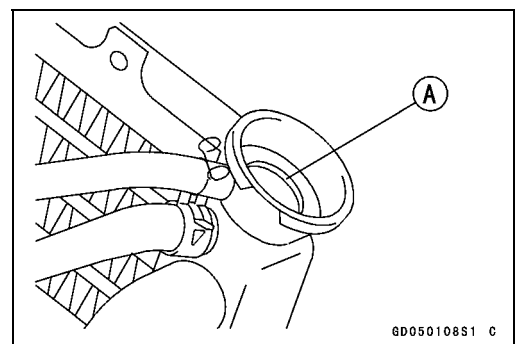

CAUTION

Soft or distilled water must be used with the antifreeze (see below for antifreeze) in the cooling system.

If hard water is used in the system, it causes scales accumulation in the water passages, and considerably reduces the efficiency of the cooling system.

3-8 COOLING SYSTEM

Coolant

Water and Coolant Mixture Ratio (Recommended)

Soft Water	:	50%
Coolant	:	50%
Freezing Point	:	-35°C (-31°F)
Total Amount	:	2.3 L (2.43 US qt)

NOTE

○ Choose a suitable mixture ratio by referring to the coolant manufacturer's directions.

- Bleed the air from the cooling system as follows.
- Start the engine with the radiator cap removed and run it until no more air bubbles [A] can be seen in the coolant.
- Tap the radiator hoses to force any air bubbles caught inside.
- Stop the engine and add coolant up to the radiator filler neck.
- Install the radiator cap.
- Start the engine, warm it up thoroughly until the radiator fan turns on and then stop the engine.
- Check the coolant level in the reserve tank after the engine cools down.
- ★ If the coolant level is lower than the low level line, add coolant to the full level line.

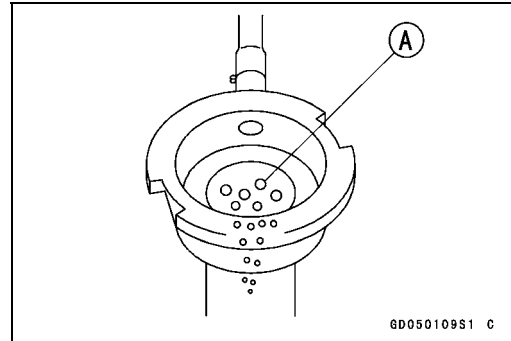

CAUTION

Do not add more coolant above the full level line.

Pressure Testing

- Remove:
 - Lower Fairing (see Frame chapter)
- Remove the radiator cap, and install a cooling system pressure tester [A] on the filler neck.

NOTE

○ Wet the cap sealing surfaces with water or coolant to prevent pressure leaks.

- Build up pressure in the system carefully until the pressure reaches 123 kPa (1.25 kgf/cm², 18 psi).

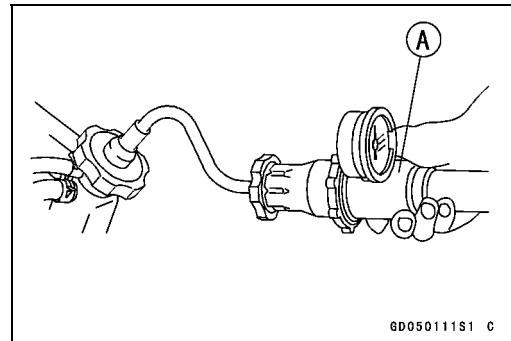

CAUTION

During pressure testing, do not exceed the pressure for which the system is designed. The maximum pressure is 123 kPa (1.25 kgf/cm², 18 psi).

- Watch the gauge for at least 6 seconds.
- ★ If the pressure holds steady, the system is all right.
- ★ If the pressure drops and no external source is found, check for internal leaks. Droplets in the engine oil indicate internal leakage. Check the cylinder head gasket and the water pump.
- Remove the pressure tester, replenish the coolant, and install the radiator cap.

Coolant

Cooling System Flushing

Over a period of time, the cooling system accumulates rust, scale, and lime in the water jacket and radiator. When this accumulation is suspected or observed, flush the cooling system. If this accumulation is not removed, it will clog up the water passage and considerably reduce the efficiency of the cooling system.

- Drain the cooling system (see Coolant Draining).
- Fill the cooling system with fresh water mixed with a flushing compound.

CAUTION
Do not use a flushing compound which is harmful to the aluminum engine and radiator. Carefully follow the instructions supplied by the manufacturer of the cleaning product.

- Warm up the engine, and run it at normal operating temperature for about ten minutes.
- Stop the engine, and drain the cooling system.
- Fill the system with fresh water.
- Warm up the engine and drain the system.
- Repeat the previous two steps once more.
- Fill the system with a permanent type coolant and bleed the air from the system (see Coolant Filling).

Coolant Filter Cleaning

Refer to the chapter of carburetor in Fuel System for the cleaning procedures.

3-10 COOLING SYSTEM

Water Pump

Water Pump Removal

- Refer to Oil Pump Removal in the Engine Lubrication System chapter.

Water Pump Installation

- Refer to Oil Pump Installation in the Engine Lubrication System chapter.

Water Pump Inspection

- Check the drainage outlet passage [A] at the bottom of the water pump body for coolant leaks.
- ★ If the mechanical seal is damaged, the coolant leaks through the seal and drains through the passage. Replace the water pump unit.

- Visually inspect the impeller [A].
- ★ If the surface is corroded, or if the blades are damaged, replace the water pump unit.

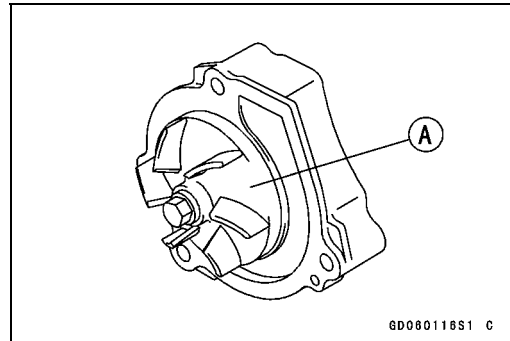

GD080116S1 C

Radiator, Radiator Fan

Radiator and Radiator Fan Removal

⚠ WARNING

The radiator fan is connected directly to the battery. The radiator fan may start even if the ignition switch is off. NEVER TOUCH THE RADIATOR FAN UNTIL THE RADIATOR FAN CONNECTOR IS DISCONNECTED. TOUCHING THE FAN BEFORE THE CONNECTOR IS DISCONNECTED COULD CAUSE INJURY FROM THE FAN BLADES.

- Remove:
 - Lower Fairings (see Frame chapter)
 - Coolant (see Coolant Draining)
 - Water Hoses [A]
 - Radiator Mounting Bolt [B]

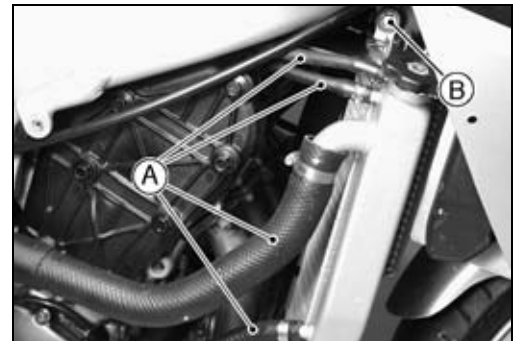

- Fan Switch Lead Connector [A]
- Water Hose [B]
- Radiator Mounting Bolts [C]
- Radiator Fan Lead Connector [D]
- Radiator

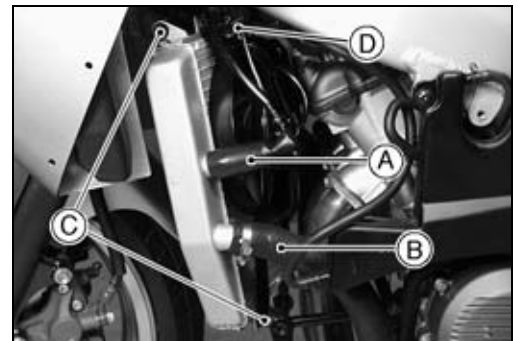

- Radiator Fan Mounting Bolts [A]
- Radiator Fan [B]

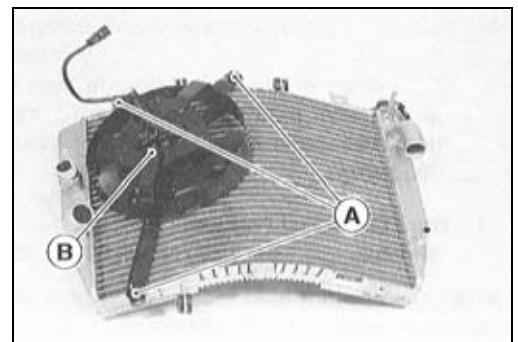

CAUTION

Do not touch the radiator core. This could damage the radiator fins, resulting in loss of cooling efficiency.

3-12 COOLING SYSTEM

Radiator, Radiator Fan

Radiator Inspection

- Check the radiator core.
- ★ If there are obstructions to air flow, remove them.
- ★ If the corrugated fins [A] are deformed, carefully straighten them.
- ★ If the air passages of the radiator core are blocked more than 20% by unremovable obstructions or irreparably deformed fins, replace the radiator with a new one.

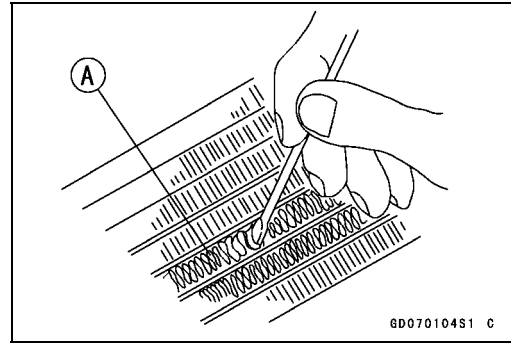

CAUTION

When cleaning the radiator with steam cleaner, be careful of the following to prevent radiator damage. Keep the steam gun [A] away more than 0.5 m (1.64 ft) [B] from the radiator core. Hold the steam gun perpendicular to the core surface. Run the steam gun following the core fin direction.

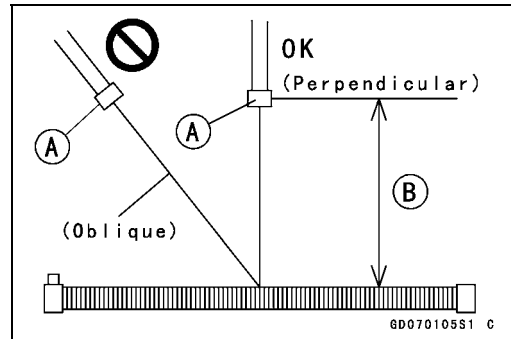

Radiator Cap Inspection

- Check the condition of the top [A] and bottom [B] valve seals and valve spring [C].
- ★ If any one of them shows visible damage, replace the cap with a new one.

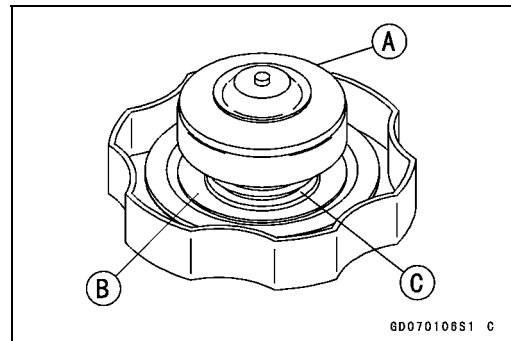

- Install the cap [A] on a cooling system pressure tester [B].

NOTE

○ Wet the cap sealing surfaces with water or coolant to prevent pressure leaks.

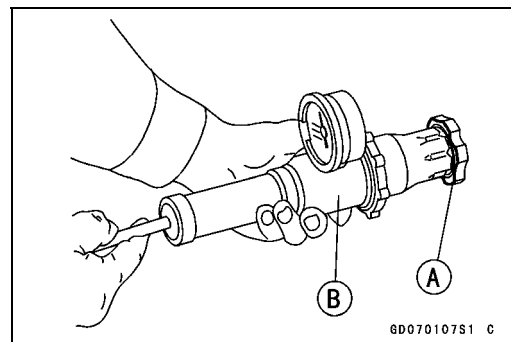

- Watching the pressure gauge, pump the pressure tester to build up the pressure until the relief valve opens: the gauge hand flicks downward. Stop pumping and measure leak time at once. The relief valve must open within the specified range in the table below and the gauge hand must remain within the same range at least 6 seconds.

Radiator Cap Relief Pressure

Standard: 93 ~ 123 kPa (0.95 ~ 1.25 kgf/cm², 14 ~ 18 psi)

- ★ If the cap cannot hold the specified pressure, or if it holds too much pressure, replace it with a new one.

Thermostat

Thermostat Removal

- Remove:
 - Coolant (see Coolant Draining)
 - Seats (see Frame chapter)
 - Fuel Tank (see Fuel System chapter)
 - Thermostat Housing Cover Bolts [A]
 - Thermostat Housing Cover [B]
 - Thermostat



Thermostat Installation

- Be sure to install the O-ring [A] on the housing cover.
- Tighten the housing cover bolts.
 - Torque - Thermostat Housing Cover Bolts: 5.9 N·m (0.60 kgf·m, 52 in·lb)**
- Fill the radiator with coolant.

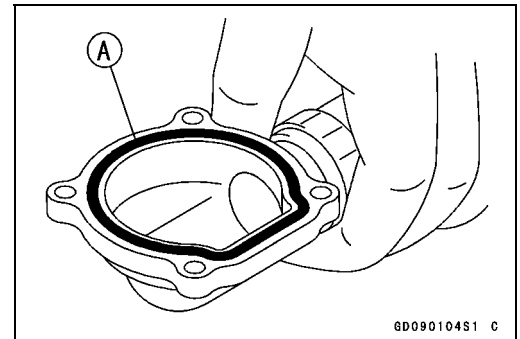

Thermostat Inspection

- Remove the thermostat, and inspect the thermostat valve [A] at room temperature.
- ★ If the valve is open, replace the thermostat with a new one.

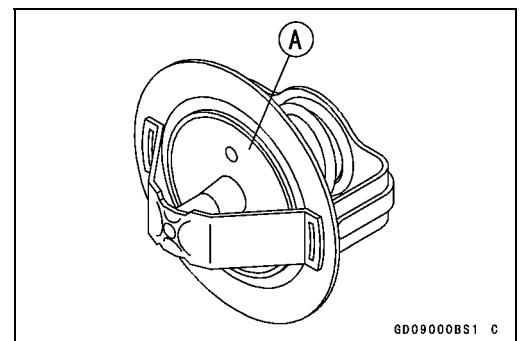

- To check valve opening temperature, suspend the thermostat [A] in a container of water and raise the temperature of the water.
- The thermostat must be completely submerged and must not touch the container sides or bottom. Suspend an accurate thermometer [B] in the water so that the heat sensitive portions [C] are located in almost the same depth. It must not touch the container, either.
- ★ If the measurement is out of the specified range, replace the thermostat with a new one.

Thermostat Valve Opening Temperature
 58 ~ 62°C (136 ~ 144°F)

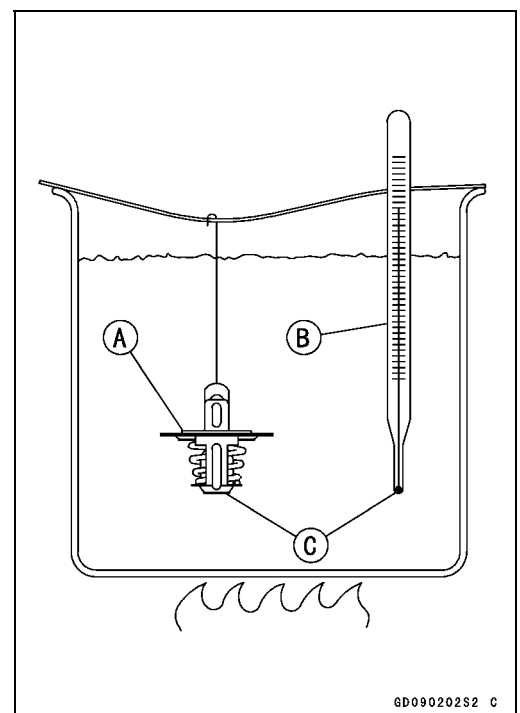

3-14 COOLING SYSTEM

Hose and Pipes

Hose Installation

- Install the hoses and pipes being careful to follow bending direction or diameter. Avoid sharp bending, kinking, flattening, or twisting.
- Install the clamps [A] as near as possible to the hose end to clear the raised rib or the fitting. This will prevent the hoses from working loose.
- The clamp screws should be positioned correctly to prevent the clamps from contacting anything.

Torque - Water Hose Clamp Screws: 2.0 N·m (0.20 kgf·m, 17 in·lb)

Hose Inspection

- Visually inspect the hoses for signs of deterioration. Squeeze the hoses. A hose should not be hard and brittle, nor should it be soft to swollen.
- Replace any damaged hoses.

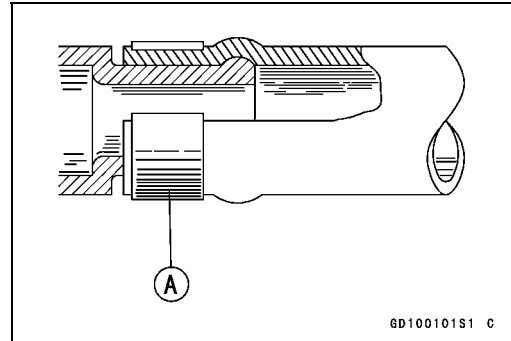

Radiator Fan Switch, Water Temperature Sensor

Radiator Fan Switch, Water Temperature Sensor Removal

CAUTION

The fan switch or the water temperature sensor should never be allowed to fall on a hard surface. Such a shock to their parts can damage them.

- Drain the coolant (see Coolant Draining).
- Remove:
 - Radiator Fan Switch Lead Connector [A]
 - Radiator Fan Switch [B]
- Seats (see Frame chapter)
- Fuel Tank (see Fuel System chapter)
- Water Temperature Sensor Lead Connector [A]
- Water Temperature Sensor [B]

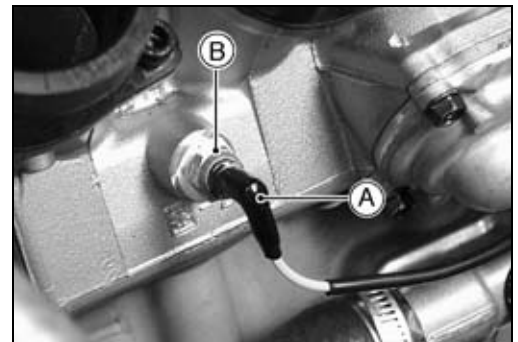
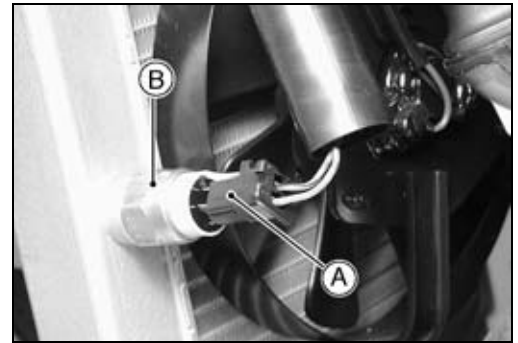

Radiator Fan Switch, Water Temperature Sensor Installation

- Apply silicone sealant to the threads of the water temperature sensor.
 - Sealant - Kawasaki Bond (Silicone Sealant): 56019-120**
- Tighten the fan switch and water temperature sensor.
 - Torque - Radiator Fan Switch: 18 N·m (1.8 kgf·m, 13 ft·lb)**
 - Water Temperature Sensor: 7.8 N·m (0.80 kgf·m, 69 in·lb)**
- Fill the coolant and bleed the air from cooling system (see Coolant Filling in the Cooling System chapter).

Radiator Fan Switch, Water Temperature Sensor Inspection

- Refer to the Electrical System chapter for these inspections.

Engine Top End

Table of Contents

Exploded View	4-2	Valve Clearance Inspection	4-19
Specifications	4-4	Valve Clearance Adjustment	4-20
Clean Air System	4-7	Valve Removal	4-23
Air Suction Valve Removal	4-7	Valve Installation	4-23
Air Suction Valve Installation	4-7	Valve Guide Removal	4-23
Air Suction Valve Inspection	4-7	Valve Guide Installation	4-24
Vacuum Switch Valve Removal ...	4-7	Valve-to-Guide Clearance	
Vacuum Switch Valve Installation	4-8	Measurement (Wobble	
Vacuum Switch Valve Test	4-8	Method)	4-24
Clean Air System Hose		Valve Seat Inspection	4-25
Inspection	4-8	Valve Seat Repair	4-25
Cylinder Head Cover	4-9	Cylinder, Pistons	4-30
Cylinder Head Cover Removal ...	4-9	Cylinder Removal	4-30
Cylinder Head Cover Installation .	4-10	Cylinder Installation	4-30
Camshaft Chain Tensioner	4-11	Piston Removal	4-30
Camshaft Chain Tensioner		Piston Installation	4-31
Removal	4-11	Cylinder Wear Inspection	4-32
Camshaft Chain Tensioner		Piston Wear Inspection	4-32
Installation	4-11	Piston Ring, Piston Ring Groove	
Camshaft, Camshaft Chain	4-12	Wear Inspection	4-32
Camshaft Removal	4-12	Piston Ring Groove Width	
Camshaft Installation	4-12	Inspection	4-33
Camshaft, Camshaft Cap Wear		Piston Ring Thickness Inspection	4-33
Inspection	4-14	Piston Ring End Gap Inspection ..	4-33
Camshaft Runout Inspection	4-14	Carburetor Holder	4-34
Cam Wear Inspection	4-14	Carburetor Holder Installation	4-34
Camshaft Chain Removal	4-15	Muffler	4-35
Cylinder Head	4-16	Muffler and Exhaust Pipe	
Cylinder Compression		Removal	4-35
Measurement	4-16	Muffler and Exhaust Pipe	
Cylinder Head Removal	4-17	Installation	4-35
Cylinder Head Installation	4-17	Muffler Body Removal	4-36
Cylinder Head Warp Inspection ...	4-18	Muffler Body Installation	4-36
Valves	4-19		

4-2 ENGINE TOP END

Exploded View

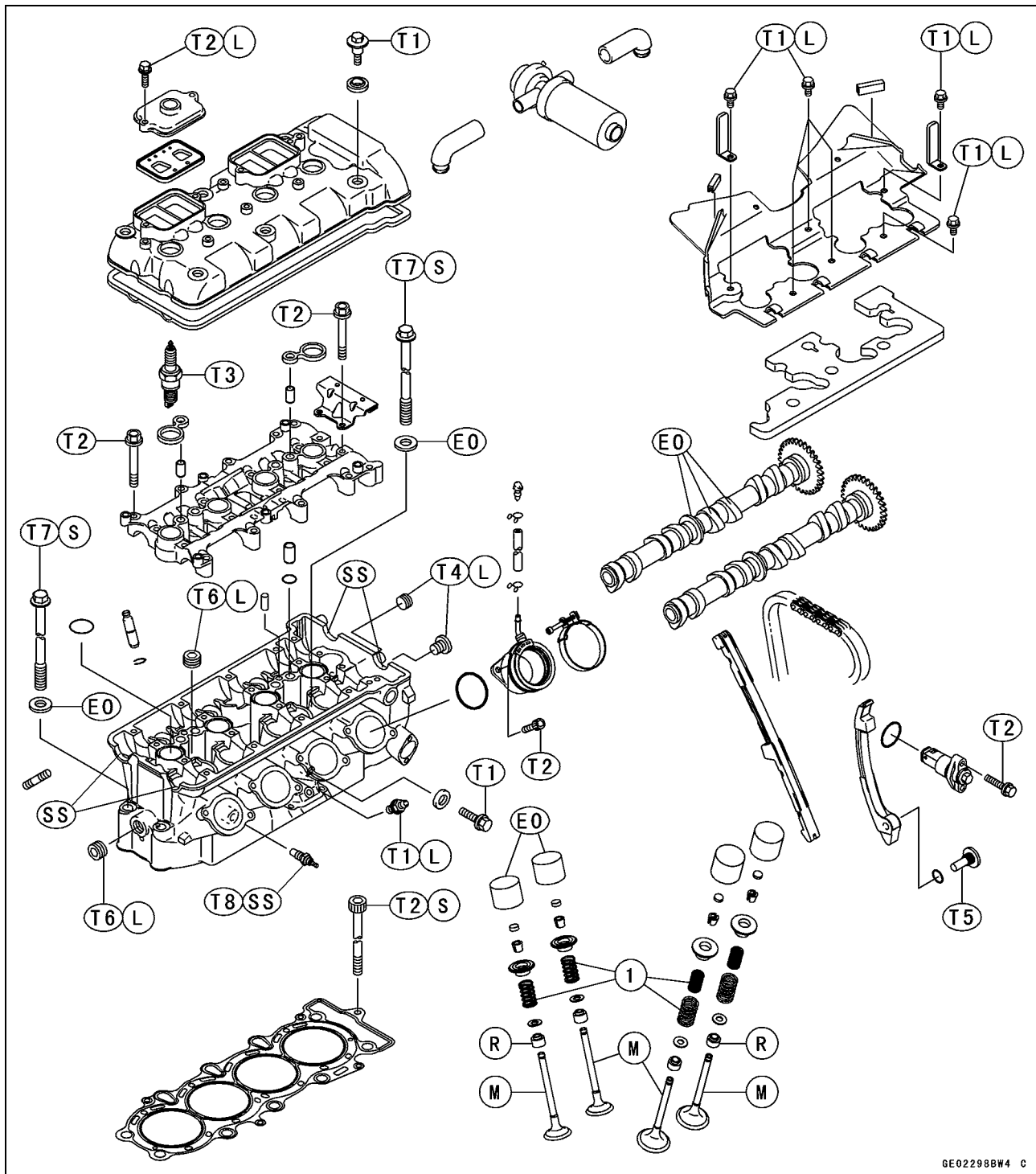

GE02298B#4 C

- 1. Closed coil end faces downward.
- T1: 9.8 N·m (1.0 kgf·m, 87 in·lb)
- T2: 12 N·m (1.2 kgf·m, 104 in·lb)
- T3: 13 N·m (1.3 kgf·m, 113 in·lb)
- T4: 15 N·m (1.5 kgf·m, 11 ft·lb)
- T5: 25 N·m (2.5 kgf·m, 18 ft·lb)
- T6: 20 N·m (2.0 kgf·m, 14.5 ft·lb)
- T7: 49 N·m (5.0 kgf·m, 36 ft·lb)

- T8: 7.8 N·m (0.80 kgf·m, 69 in·lb)
- E0: Apply engine oil.
- L: Apply a non-permanent locking agent.
- M: Apply molybdenum disulfide grease.
- R: Replacement Parts
- S: Follow the specific tightening sequence.
- SS: Apply silicone sealant.

Exploded View

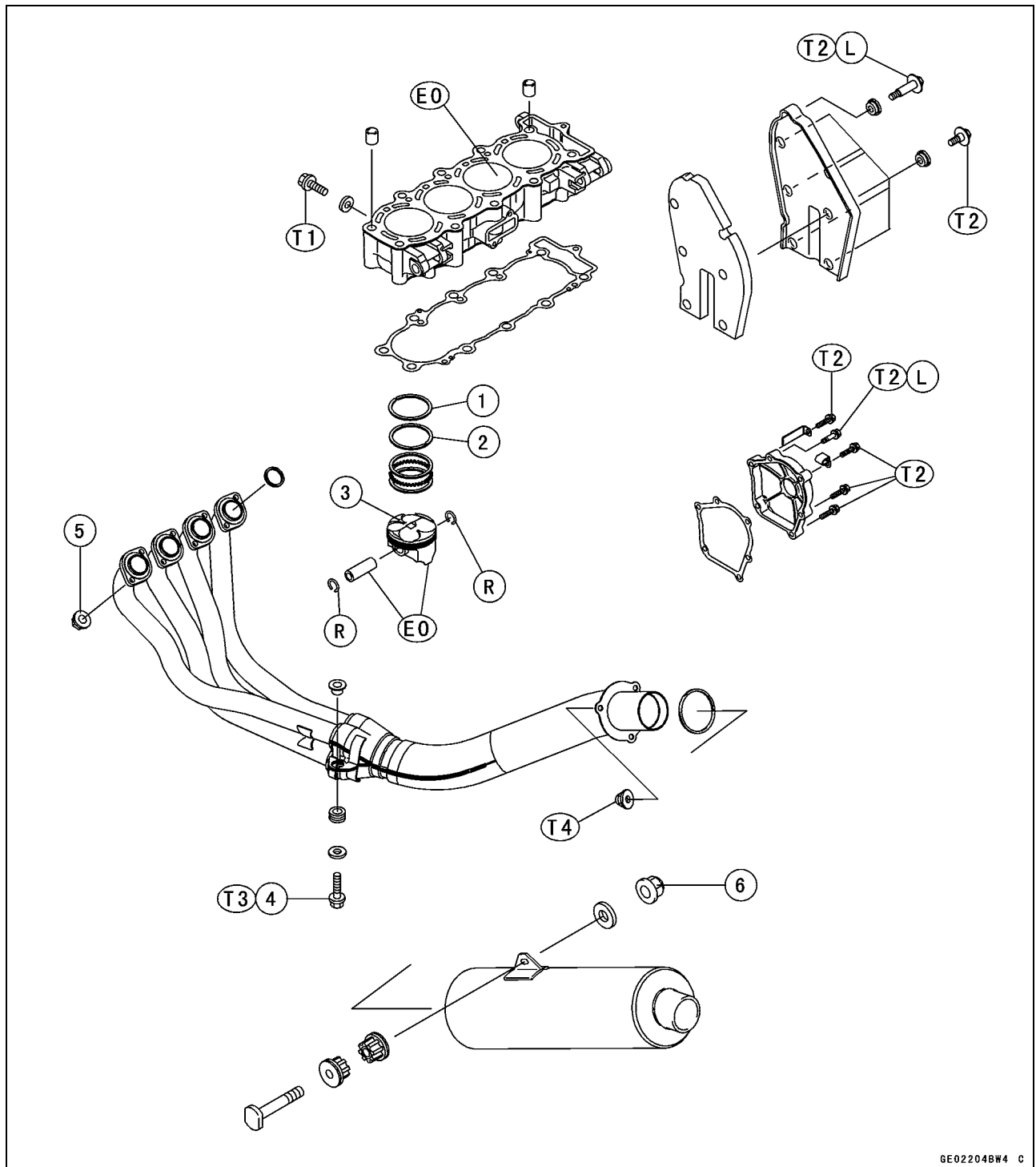

1. R marked side face up.
 2. RN marked side face up.
 3. A marking hollow facing forward.
 4. Exhaust Pipe Mounting Bolt
 5. Exhaust Pipe Holder Nuts
 6. Muffler Mounting Nut
- T1: 9.8 N·m (1.0 kgf·m, 87 in·lb)

- T2: 12 N·m (1.2 kgf·m, 104 in·lb)
 T3: 34 N·m (3.5 kgf·m, 25 ft·lb)
 T4: 45 N·m (4.5 kgf·m, 33 ft·lb)
 EO: Apply engine oil.
 L: Apply a non-permanent locking agent.
 R: Replacement Parts

4-4 ENGINE TOP END

Specifications

Item	Standard	Service Limit
Clean Air System		
Vacuum Switch Valve Closing Pressure	Open → Close 57 ~ 65 kPa (430 ~ 490 mmHg)	— — —
Camshafts		
Cam Height:		
Exhaust	34.345 ~ 34.453 mm (1.352 ~ 1.356 in.)	34.24 mm (1.348 in.)
Inlet	35.146 ~ 35.254 mm (1.384 ~ 1.388 in.)	35.04 mm (1.380 in.)
Camshaft Journal, Camshaft Cap Clearance	0.038 ~ 0.081 mm (0.0015 ~ 0.0032 in.)	0.17 mm (0.0067 in.)
Camshaft Journal Diameter	23.940 ~ 23.962 mm (0.9425 ~ 0.9434 in.)	23.91 mm (0.941 in.)
Camshaft Bearing Inside Diameter	24.000 ~ 24.021 mm (0.9449 ~ 0.9457 in.)	24.08 mm (0.948 in.)
Camshaft Runout	TIR 0.02 mm (0.0008 in.) or less	TIR 0.1 mm (0.004 in.)
Cylinder Head		
Cylinder Compression	(usable range) 950 ~ 1 450 kPa (9.7 ~ 14.8 kgf/cm ² , 138 ~ 210 psi) @350 r/min (rpm)	— — —
Cylinder Head Warp	— — —	0.05 mm (0.002 in.)
Valves		
Valve Clearance:		
Exhaust	0.22 ~ 0.31 mm (0.0087 ~ 0.0122 in.)	— — —
Inlet	0.11 ~ 0.19 mm (0.0043 ~ 0.0075 in.)	— — —
Valve Head Thickness:		
Exhaust	1.0 mm (0.04 in.)	0.6 mm (0.024 in.)
Inlet	0.5 mm (0.02 in.)	0.25 mm (0.010 in.)
Valve Stem Bend	TIR 0.01mm (0.0004 in.) or less	TIR 0.05 mm (0.002 in.)
Valve Stem Diameter:		
Exhaust	3.955 ~ 3.970 mm (0.1557 ~ 0.1563 in.)	3.94 mm (0.155 in.)
Inlet	3.975 ~ 3.990 mm (0.1565 ~ 0.1571 in.)	3.96 mm (0.156 in.)
Valve Guide Inside Diameter		
Exhaust	4.000 ~ 4.012 mm (0.1575 ~ 0.1580 in.)	4.08 mm (0.161 in.)
Inlet	4.000 ~ 4.012 mm (0.1575 ~ 0.1580 in.)	4.08 mm (0.161 in.)
Valve/Valve Guide Clearance (Wobble Method):		
Exhaust	0.10 ~ 0.18 mm (0.004 ~ 0.007 in.)	0.35 mm (0.014 in.)

Specifications

Item	Standard	Service Limit
Inlet	0.03 ~ 0.12 mm (0.0012 ~ 0.0047 in.)	0.29 mm (0.011 in.)
Valve Seat Cutting Angle	45°, 32°, 60°	— — —
Valve Seat Surface:		
Width:		
Exhaust	0.5 ~ 1.0 mm (0.02 ~ 0.04 in.)	— — —
Inlet	0.5 ~ 1.0 mm (0.02 ~ 0.04 in.)	— — —
Outside Diameter:		
Exhaust	22.1 ~ 22.3 mm (0.870 ~ 0.878 in.)	— — —
Inlet	26.4 ~ 26.6 mm (1.039 ~ 1.047 in.)	— — —
Valve Spring Free Length:		
Exhaust (Inner)	49.0 mm (1.93 in.)	47.6 mm (1.87 in.)
Inlet (Inner)	44.1 mm (1.44 in.)	42.6 mm (1.68 in.)
Inlet (Outer)	48.2 mm (1.90 in.)	46.6 mm (1.83 in.)
Cylinder, Piston		
Cylinder Inside Diameter	65.960 ~ 65.972 mm (2.5968 ~ 2.5973 in.)	66.06 mm (2.601 in.)
Piston Diameter	65.935 ~ 65.950 mm (2.5957 ~ 2.5965 in.)	65.78 mm (2.590 in.)
Piston/Cylinder Clearance:	0.010 ~ 0.037 mm (0.0004 ~ 0.0015 in.)	— — —
Piston Ring/Groove Clearance		
Top	0.05 ~ 0.09 mm (0.0020 ~ 0.0035 in.)	0.19 mm (0.0075 in.)
Second	0.03 ~ 0.07 mm (0.0012 ~ 0.0028 in.)	0.17 mm (0.0067 in.)
Piston Ring Groove Width:		
Top	0.84 ~ 0.86 mm (0.0331 ~ 0.0339 in.)	0.94 mm (0.037 in.)
Second	0.82 ~ 0.84 mm (0.0323 ~ 0.0331 in.)	0.92 mm (0.036 in.)
Piston Ring Thickness:		
Top	0.77 ~ 0.79 mm (0.0303 ~ 0.0311 in.)	0.70 mm (0.028 in.)
Second	0.77 ~ 0.79 mm (0.0303 ~ 0.0311 in.)	0.70 mm (0.028 in.)
Piston Ring End Gap:		
Top	0.15 ~ 0.30 mm (0.0059 ~ 0.0118 in.)	0.6 mm (0.024 in.)
Second	0.30 ~ 0.45 mm (0.0118 ~ 0.0177 in.)	0.8 mm (0.031 in.)

4-6 ENGINE TOP END

Specifications

- Special Tools - Compression Gauge, 20 kgf/cm²: 57001-221
 - Valve Spring Compressor Assembly: 57001-241
 - Piston Pin Puller Assembly: 57001-910
 - Valve Seat Cutter, 45° - ϕ 27.5: 57001-1114
 - Valve Seat Cutter, 45° - ϕ 32: 57001-1115
 - Valve Seat Cutter, 32° - ϕ 28: 57001-1119
 - Valve Seat Cutter, 32° - ϕ 30: 57001-1120
 - Valve Seat Cutter, 60° - ϕ 30: 57001-1123
 - Valve Seat Cutter Holder Bar: 57001-1128
 - Valve Spring Compressor Adapter, ϕ 20: 57001-1154
 - Valve Spring Compressor Adapter, ϕ 22: 57001-1202
 - Spark Plug Wrench, Hex 16: 57001-1262
 - Valve Guide Arbor, ϕ 4: 57001-1273
 - Valve Guide Reamer, ϕ 4: 57001-1274
 - Valve Seat Cutter Holder, ϕ 4: 57001-1275
 - Fork Oil Level Gauge: 57001-1290
 - Compression Gauge Adapter, M10 × 1.0: 57001-1317
 - Valve Seat Cutter, 60° - ϕ 33: 57001-1334
- Sealant - Kawasaki Bond (Silicone Sealant): 56019-120

Clean Air System

Air Suction Valve Removal

- Remove:
 - Seats (see Frame chapter)
 - Fuel Tank, Air Cleaner Housing (see Fuel System chapter)
- Separate the intake silencer [A] from the vacuum switch valve [B].
- Remove:
 - Vacuum Switch Valve with the Hoses
 - Air Suction Valve Cover Bolts [C]
 - Air Suction Valve Cover [D]
 - Air Suction Valve

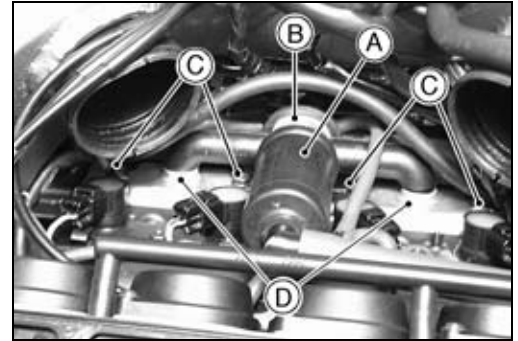

Air Suction Valve Installation

- Install the air suction valve so that its wider side [A] of the reed faces the rear.
- Apply a non-permanent locking agent to the threads of the air suction valve cover bolts, and tighten them with the specified torque.

Torque - Air Suction Valve Cover Bolts: 12 N·m (1.2 kgf·m, 104 in·lb)

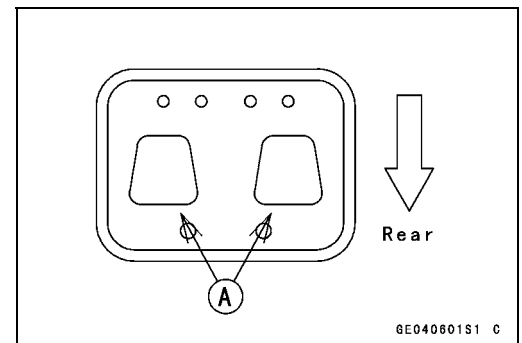

GE040601S1 C

Air Suction Valve Inspection

- Visually inspect the reeds [A] for cracks, folds, warps, heat damage, or other damage.
- ★ If there is any doubt as to the condition of the reed, replace the air suction valve as an assembly.
- Check the reed contact areas [B] of the valve holder for grooves, scratches, any signs of separation from the holder, or heat damage.
- ★ If there is any doubt as to the condition of the reed contact areas, replace the air suction valve as an assembly.
- If any carbon or other foreign particles have accumulated between the reed and the reed contact area, wash the valve assembly with a high flash-point solvent.

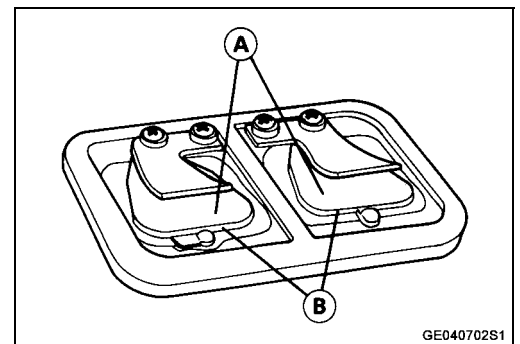

GE040702S1

CAUTION

Do not scrape off the deposits with a scraper as this could damage the rubber, requiring replacement of the suction valve assembly.

Vacuum Switch Valve Removal

- Remove the vacuum switch valve (see Air Suction Valve Removal).

4-8 ENGINE TOP END

Clean Air System

Vacuum Switch Valve Installation

- Install the vacuum switch valve so that the air hole [A] faces downwards.
- Route the hoses correctly (see General Information chapter).

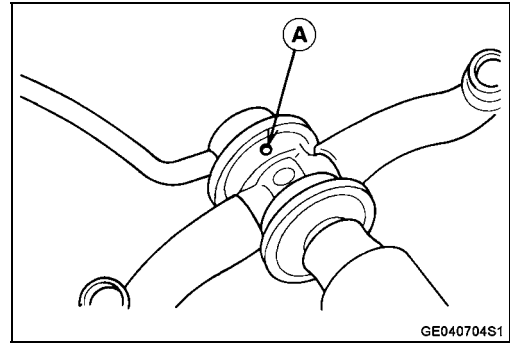

Vacuum Switch Valve Test

- Remove:
 - Fuel Tank, Air Cleaner Housing (see Fuel System chapter)
 - Vacuum Switch Valve
- Connect a vacuum gauge [A] and syringe [B] or fork oil level gauge to the vacuum hoses as shown.

Special Tool - Fork Oil Level Gauge: 57001-1290

Air Flow [C]

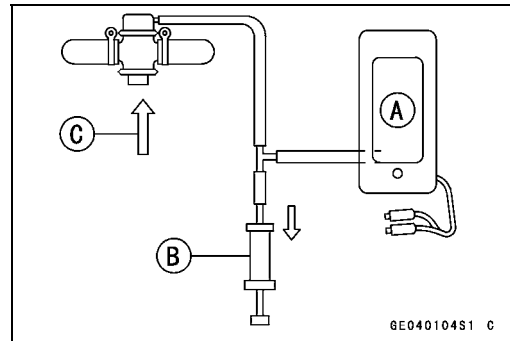

- Gradually raise the vacuum (lower the pressure) applied to the vacuum switch valve, and check the valve operation. When the vacuum is low, the vacuum switch valve should permit air to flow. When the vacuum raises to valve closing pressure, it should stop air flow.

Spring [A]

Diaphragm [B]

Valve [C]

Low Vacuum [D]

Secondary Air Flow [E]

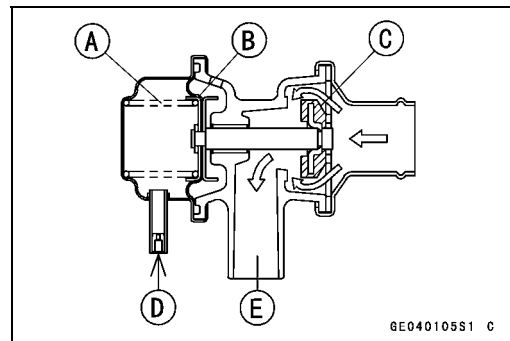

- ★ If the vacuum switch valve does not operate as described, replace it with a new one.

NOTE

○ To check air flow through the vacuum switch valve, just blow through the air cleaner hose.

Vacuum Switch Valve Closing Pressure (Open → Close)

Standard: 57 ~ 65 kPa (430 ~ 490 mmHg)

High Vacuum [A]

Secondary air cannot flow [B]

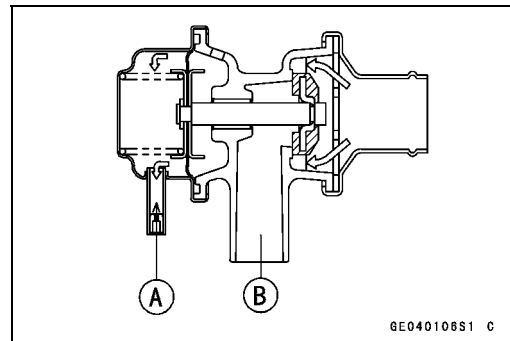

Clean Air System Hose Inspection

- Be certain that all the hoses are routed without being flattened or kinked, and are connected correctly to the air cleaner housing, vacuum switch valve, #1 and #4 carburetor holders and air suction valve covers.
- ★ If they are not, correct them. Replace them if they are damaged.

Cylinder Head Cover

Cylinder Head Cover Removal

- Remove:
 - Lower Fairing (see Frame chapter)
 - Coolant (drain, see Cooling System chapter) Other than US, CAL Models
 - Seats (see Frame chapter)
 - Fuel Tank, Air Cleaner Housing and Carburetor (see Fuel System chapter)
 - Vacuum Valve (California Model only)
 - Vacuum Switch Valve and Hoses
 - Stick Coil (see Electrical System)
 - Engine Side Cover [A] and Bolts [B]
- Turn the handlebar to left side.
- Remove:
 - Radiator Mount Bolts [A]
 - Radiator Bracket Bolts [B]
 - Radiator Bracket [C]
- Move the radiator toward the down [D] and put the suitable support [E] under the radiator.

CAUTION

Do not touch the radiator core. This could damage the radiator fins, resulting in loss of cooling efficiency.

- Remove:
 - Baffle Plate Bolts [A]
 - Baffle Plate [B]

NOTE

○ If the baffle plate cannot easily be removed, remove the air suction valve covers.

- Remove the cylinder head cover bolts [A].

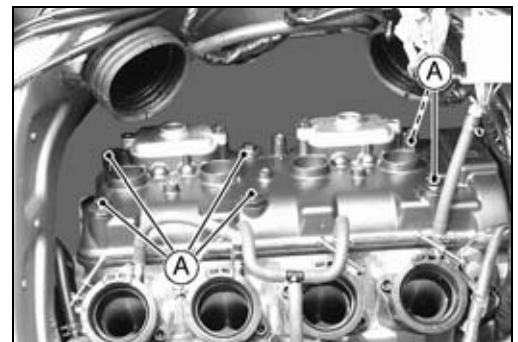
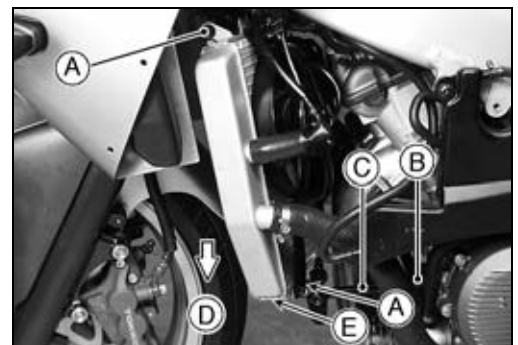
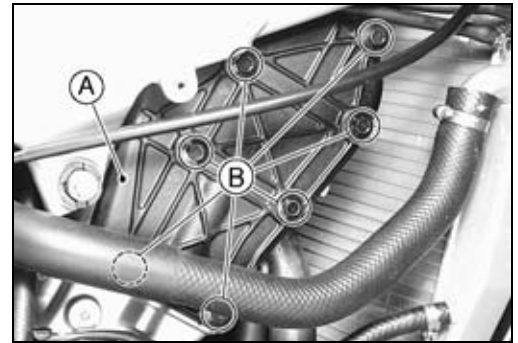

4-10 ENGINE TOP END

Cylinder Head Cover

- Remove the cylinder head cover [A].

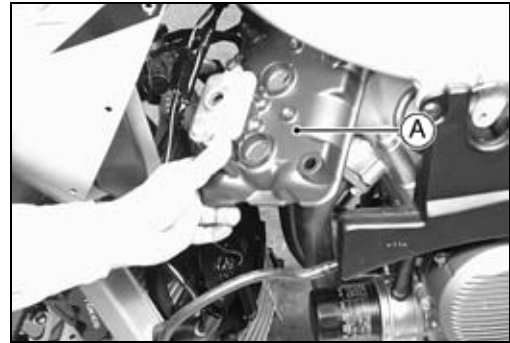

Cylinder Head Cover Installation

- Replace the head cover gasket with a new one if damaged.
- Apply silicone sealant to the cylinder head as shown [A].
Sealant - Kawasaki Bond (Silicone Sealant): 56019-120

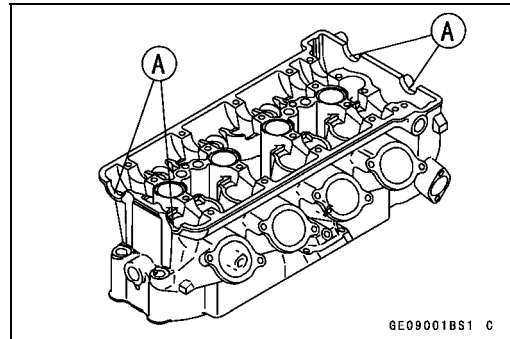

- Be sure to install the pins [A] and rubber gaskets [B].

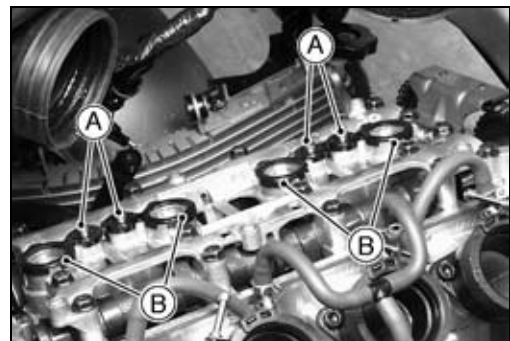

- Install the washer with the metal side [A] faces upward.
- Tighten:
Torque - Cylinder Head Cover Bolts: 9.8 N·m (1.0 kgf·m, 87 in·lb) [B]
Baffle Plate Bolts: 9.8 N·m (1.0 kgf·m, 87 in·lb)

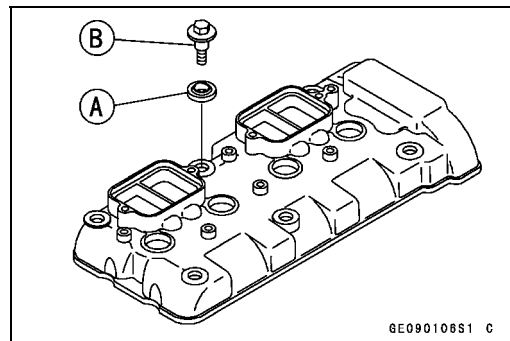

- Apply a non-permanent locking agent to the threads of the engine side cover bolt [A].
- Tighten:
Torque - Engine Side Cover Bolts: 12 N·m (1.2 kgf·m, 104 in·lb) [A] [B]

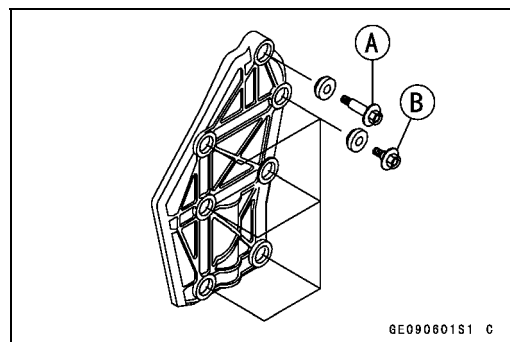

Camshaft Chain Tensioner

Camshaft Chain Tensioner Removal

CAUTION

This is a non-return type camshaft chain tensioner. The push rod does not return to its original position once it moves out to take up camshaft chain slack. Observe all the rules listed below:

Observe all the rules listed below:

When removing the tensioner, do not take out the mounting bolts only halfway. Retightening the mounting bolts from this position could damage the tensioner and the camshaft chain. Once the bolts are loosened, the tensioner must be removed and reset as described in "Camshaft Chain Tensioner Installation."

Do not turn over the crankshaft while the tensioner is removed. This could upset the camshaft chain timing, and damage the valves.

- Remove:
 - Seats (see Frame chapter)
 - Fuel Tank (see Fuel System chapter)
 - Cap Bolt [A]
 - Washer [B]
 - Spring [C]
 - Rod [D]
- Remove the mounting bolts [E] and take off the camshaft chain tensioner.

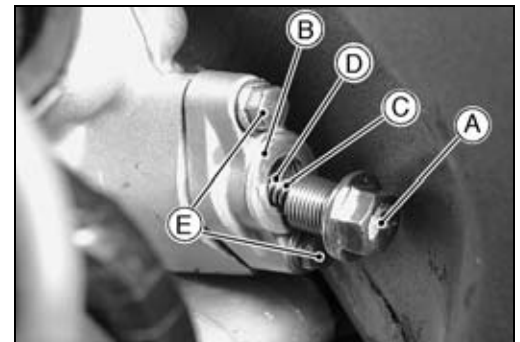

Camshaft Chain Tensioner Installation

- Release the stopper [A] and push the push rod [B] into the tensioner body [C].
- Insert the push rod so that the push rod teeth are leaved five notches.
- Install the tensioner body so that the stopper faces upward.

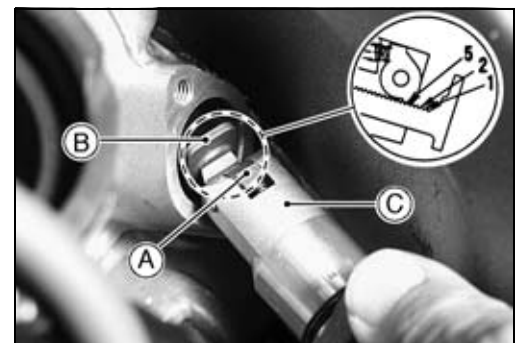

- Tighten:
 - Torque - Camshaft Chain Tensioner Mounting Bolts [B]: 12 N·m (1.2 kgf·m, 104 in·lb)**
- Install the spring and washer.
- Tighten the cap bolt [A].
- Turn the crankshaft 2 turns clockwise to allow the tensioner to expand and recheck the camshaft chain timing.

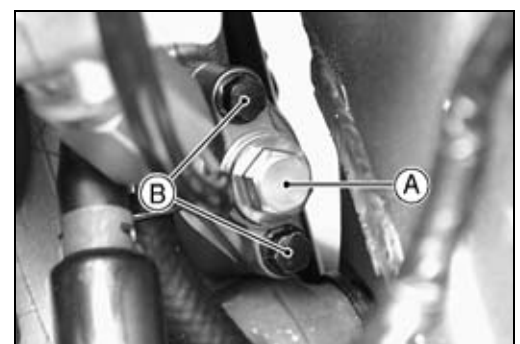

4-12 ENGINE TOP END

Camshaft, Camshaft Chain

Camshaft Removal

- Remove:
 - Cylinder Head Cover (see Cylinder Head Cover Removal)
 - Pickup Coil Cover
- Position the crankshaft at #1, 4 piston TDC.
 - [A] TDC mark for #1, 4 Pistons
 - [B] Timing Mark (crankcase halves mating surface)

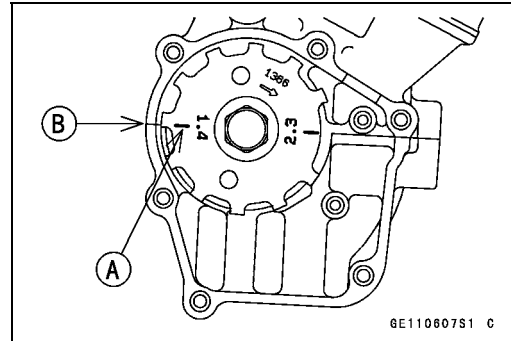

- Remove:
 - Camshaft Chain Tensioner (see Camshaft Chain Tensioner Removal)
 - Rubber Gaskets and Cylinder Head Cover Gasket
 - Camshaft Cap Bolts
 - Chain Guide [A]
 - Camshaft Cap [B]
 - Camshafts [C]
- Stuff a clean cloth into the chain tunnel to keep any parts from dropping into the crankcase.

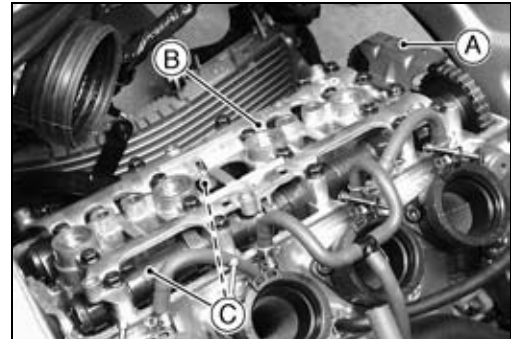

CAUTION

The crankshaft may be turned while the camshafts are removed. Always pull the chain taut while turning the crankshaft. This avoids kinking the chain on the lower (crankshaft) sprocket. A kinked chain could damage both the chain and the sprocket.

Camshaft Installation

- Be sure to install the following parts.
 - [A] O-rings
 - [B] Pins

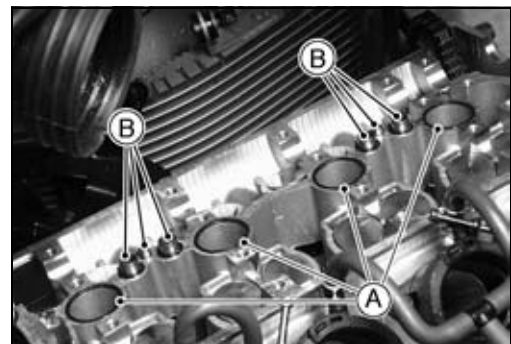

- Apply engine oil to all cam parts and journals.
- If a new camshaft is to be used, apply a thin coat of molybdenum disulfide grease to the cam surfaces.

NOTE

- The exhaust camshaft has a 117 EX mark [A] and the inlet camshaft has a 117 IN mark [B]. Be careful not to mix up these shafts.

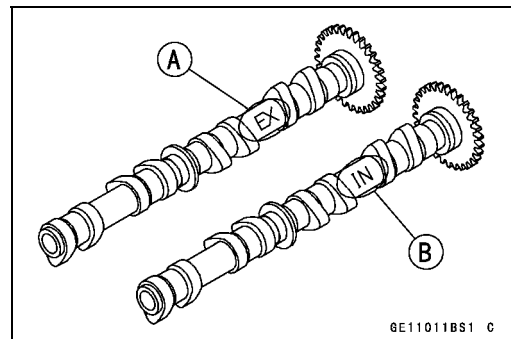

Camshaft, Camshaft Chain

- Position the crankshaft at #1, 4 piston TDC.
 - Pull the tension side (exhaust side) [A] of the chain taut to install the chain.
 - Engage the camshaft chain with the camshaft sprockets so that the timing marks on the sprockets are positioned as shown.
- The timing marks of #1, 4 must be aligned with the lower surface of crankcase of rear side [E].

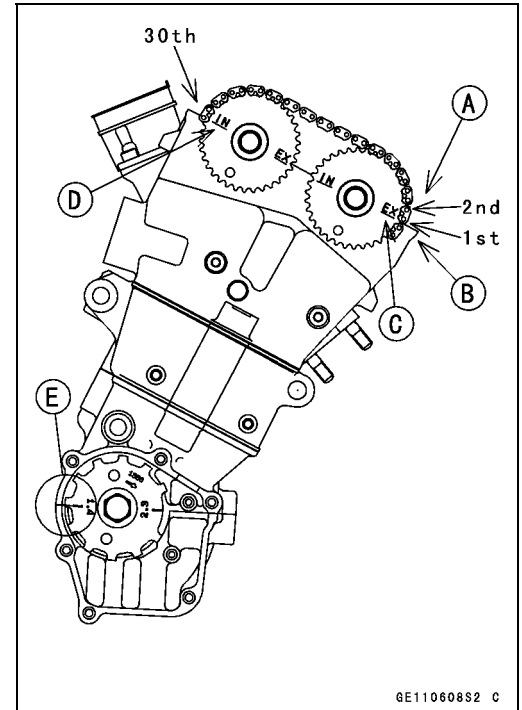

- The timing marks must be aligned with the cylinder head upper surface [B].
- [C] EX mark
[D] IN mark

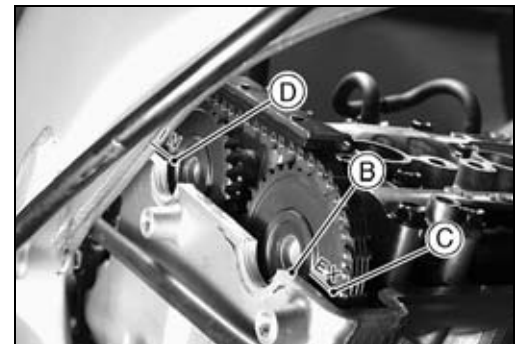

- Install the camshaft cap and chain guide.
- First tighten the camshaft cap and all chain guide bolts evenly to seat the camshaft in place, then tighten all bolts following the specified tightening sequence.

Torque - Camshaft Cap Bolts: 12 N·m (1.2 kgf·m, 104 in·lb)

Camshaft Chain Guide Bolts: 12 N·m (1.2 kgf·m, 104 in·lb)

- Tighten the camshaft chain tensioner (see Camshaft Chain Tensioner Installation).
- Install the cylinder head cover (see Cylinder Head Cover Installation).

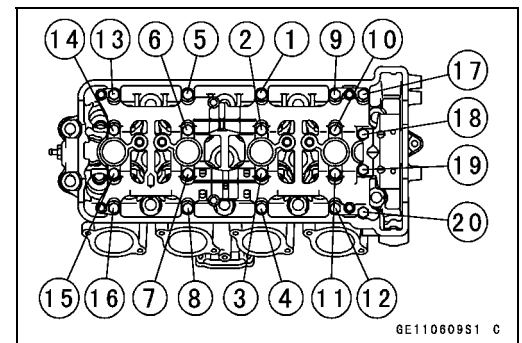

4-14 ENGINE TOP END

Camshaft, Camshaft Chain

Camshaft, Camshaft Cap Wear Inspection

- Cut strips of plastigage to journal width. Place a strip on each journal parallel to the camshaft installed in the correct position.
- Measure each clearance between the camshaft journal and the camshaft cap using plastigage (press gauge) [A].
- Tighten:

Torque - Camshaft Cap Bolts: 12 N·m (1.2 kgf·m, 104 in·lb)
Camshaft Chain Guide Bolts: 12 N·m (1.2 kgf·m, 104 in·lb)

NOTE

○ Do not turn the camshaft when the plastigage is between the journal and camshaft cap.

Camshaft Journal, Camshaft Cap Clearance

Standard: 0.038 ~ 0.081 mm (0.0015 ~ 0.0032 in.)

Service Limit: 0.17 mm (0.0067 in.)

- ★ If any clearance exceeds the service limit, measure the diameter of each camshaft journal with a micrometer.

Camshaft Journal Diameter

Standard: 23.940 ~ 23.962 mm (0.9425 ~ 0.9434 in.)

Service Limit: 23.91 mm (0.941 in.)

- ★ If the camshaft journal diameter is less than the service limit, replace the camshaft with a new one and measure the clearance again.
- ★ If the clearance still remains out of the limit, replace the cylinder head unit.

Camshaft Runout Inspection

- Remove the camshaft.
- Set the camshaft in a camshaft alignment jig or on V blocks.
- Measure runout with a dial gauge at the specified place as shown.
- ★ If the runout exceeds the service limit, replace the shaft.

Camshaft Runout

Standard: TIR 0.1 mm (0.004 in.)

Cam Wear Inspection

- Remove the camshaft.
- Measure the height [A] of each cam with a micrometer.
- ★ If the cams are worn down past the service limit, replace the camshaft.

Cam Height

Standard:

Exhaust 34.345 ~ 34.453 mm (1.352 ~ 1.356 in.)

Inlet 35.146 ~ 35.254 mm (1.384 ~ 1.388 in.)

Service Limit:

Exhaust 34.24 mm (1.348 in.)

Inlet 35.04 mm (1.380 in.)

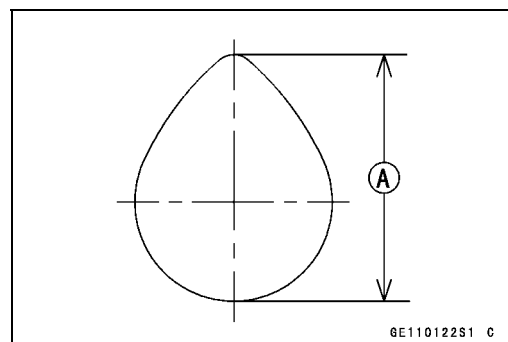
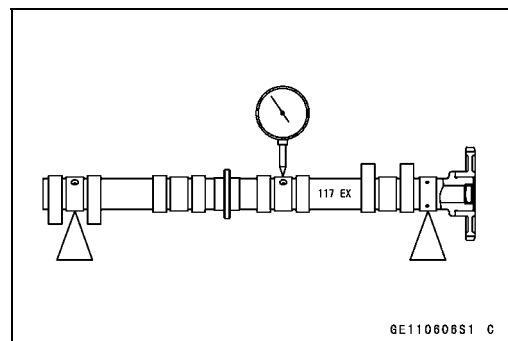
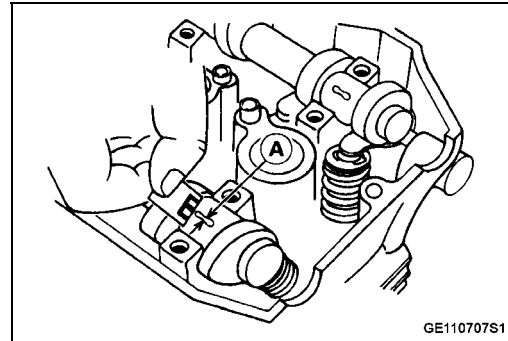

Camshaft, Camshaft Chain

Camshaft Chain Removal

- Split the crankcase (see Crankshaft/Transmission chapter).
- Remove the camshaft chain [A] from the crankshaft sprocket.

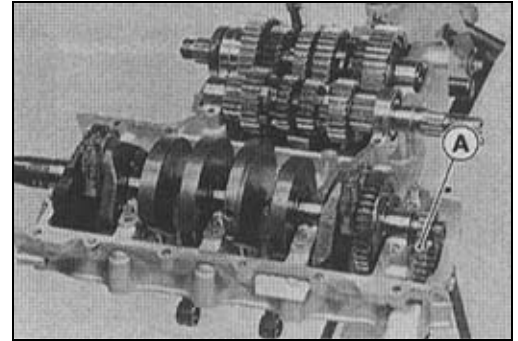

4-16 ENGINE TOP END

Cylinder Head

Cylinder Compression Measurement

NOTE

○ Use the battery which is fully charged.

- Warm up the engine thoroughly.
- Stop the engine.
- Remove:
 - Seats (see Frame chapter)
 - Fuel Tank (see Fuel System chapter)
 - Air Cleaner Housing (see Fuel System chapter)
 - Stick Coils
 - Spark Plugs

Special Tool - Spark Plug Wrench, Hex 16: 57001-1262

- Attach the compression gauge [A] and adapter [B] firmly into the spark plug hole.
- Using the starter motor, turn the engine over with the throttle fully open until the compression gauge stops rising; the compression is the highest reading obtainable.

Special Tool - Compression Gauge, 20 kgf/cm²: 57001-221
Compression Gauge Adapter, M10 × 1.0: 57001-1317

Cylinder Compression

Usable Range: 950 ~ 1450 kPa (9.7 ~ 14.8 kgf/cm², 138 ~ 210 psi) @350 r/min (rpm)

- Repeat the measurement for the other cylinders.
- Install the spark plugs and tighten them.

Torque - Spark Plugs: 13 N·m (1.3 kgf·m, 113 in·lb)

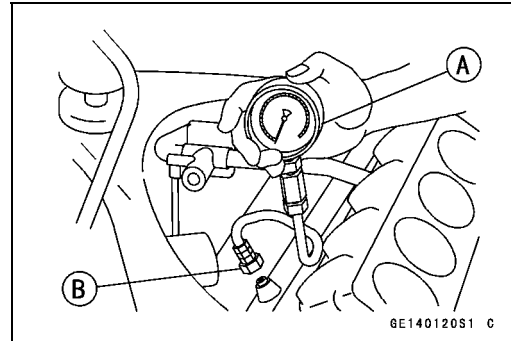

The following table should be consulted if the obtainable compression reading is not within the usable range.

Problem	Diagnosis	Remedy (Action)
Cylinder compression is higher than usable range	Carbon accumulation on piston and in combustion chamber possibly due to damaged valve stem oil seal and/or damaged piston oil rings (This may be indicated by white exhaust smoke).	Remove the carbon deposits and replace damaged parts if necessary.
	Incorrect cylinder head gasket thickness.	Replace the gasket with a standard part.
Cylinder compression is lower than usable range	Gas leakage around cylinder head	Replace damaged gasket and check cylinder head warp.
	Bad condition of valve seating	Repair if necessary.
	Incorrect valve clearance.	Adjust the valve clearance.
	Incorrect piston/cylinder clearance	Replace the piston and/or cylinder
	Piston seizure.	Inspect the cylinder and replace/repair the cylinder and/or piston as necessary.
	Bad condition of piston ring and/or piston ring grooves	Replace the piston and/or the piston rings.

Cylinder Head

Cylinder Head Removal

- Drain the coolant (see Cooling System chapter).
- Remove:
 - Cylinder Head Cover (see Cylinder Head Cover Removal)
 - Camshaft Chain Tensioner (see Camshaft Chain Tensioner Removal)
 - Camshafts (see Camshaft Removal)
 - Water Temperature Sensor Lead Connector [A]
 - Oil Hose Banjo Bolt [B]
- Remove the 6 mm cylinder head bolts [A], and then the 10 mm cylinder head bolts [B].
- Take off the cylinder head.

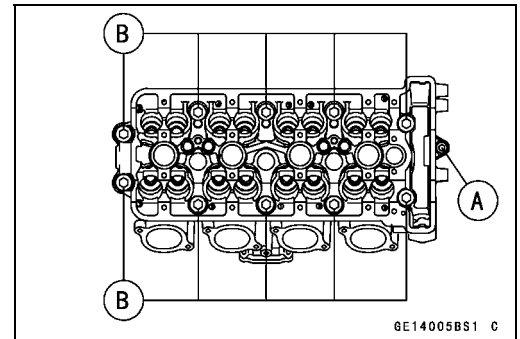

Cylinder Head Installation

NOTE

○The camshaft cap is machined with the cylinder head, so if a new cylinder head is installed, use the cap that is supplied with the new head.

- Install a new cylinder head gasket and knock pins.
- Apply engine oil to both sides [A] of the cylinder head bolt washers [B].
- Tighten the 10 mm cylinder head bolts following the tightening sequence [1 ~ 10].
 - Torque - Cylinder Head Bolts (10mm)**
 - First: 20 N·m (2.0 kgf·m, 14.5 ft·lb)
 - Final (Used Bolts): 49 N·m (5.0 kgf·m, 36 ft·lb)
- Tighten the 6 mm cylinder head bolts [11].
 - Torque - Cylinder Head Bolts (6 mm): 12 N·m (1.2 kgf·m, 104 in·lb)**
- Tighten the oil hose banjo bolt.
 - Torque - Oil Hose Banjo Bolt: 25 N·m (2.5 kgf·m, 18.0 ft·lb)**

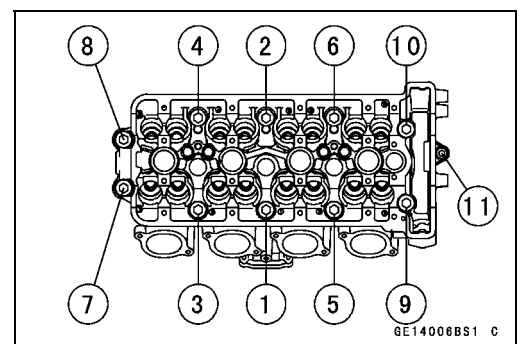
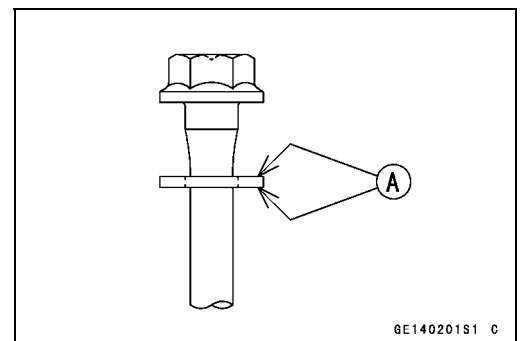

4-18 ENGINE TOP END

Cylinder Head

Cylinder Head Warp Inspection

- Lay a straightedge across the lower surface of the cylinder head at several positions.
- Use a thickness gauge [A] to measure the space between the straightedge [B] and the head.

Cylinder Head Warp

Standard: - - -

Service Limit: 0.05 mm (0.002 in.)

- ★ If the cylinder head is warped more than the service limit, replace it.
- ★ If the cylinder head is warped less than the service limit, repair the head by rubbing the lower surface on emery paper secured to a surface plate (first No. 200, then No. 400).

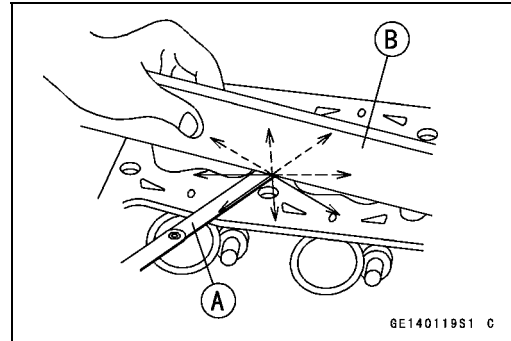

Valves

Valve Clearance Inspection

NOTE

○ Valve clearance must be checked and adjusted when the engine is cold (at room temperature).

- Remove:
 - Lower Fairings (see Frame chapter)
 - Crankshaft Sensor Cover
 - Cylinder Head Cover (see Cylinder Head Cover Removal)
- Position the crankshaft at 1,4 piston TDC.
 - TDC Mark [A] for #1, 4 Pistons
 - Timing Mark [B]

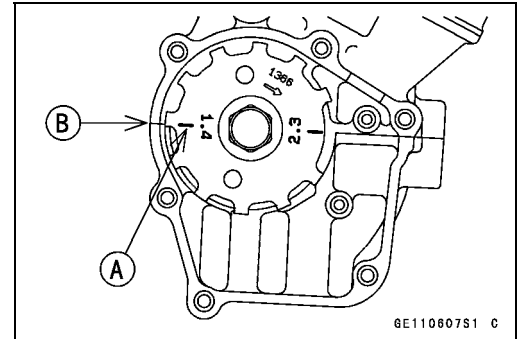

- Using a thickness gauge [A], measure the valve clearance between the cam and the valve lifter.

Valve Clearance

Standard:

IN	0.11 ~ 0.19 mm (0.0043 ~ 0.0075 in.)
EX	0.22 ~ 0.31 mm (0.0087 ~ 0.0122 in.)



- When positioning #4 piston TDC at the end of the compression stroke:

Inlet valve clearance of #2 and #4 cylinders
 Exhaust valve clearance of #3 and #4 cylinders
 Measuring Valve [A]

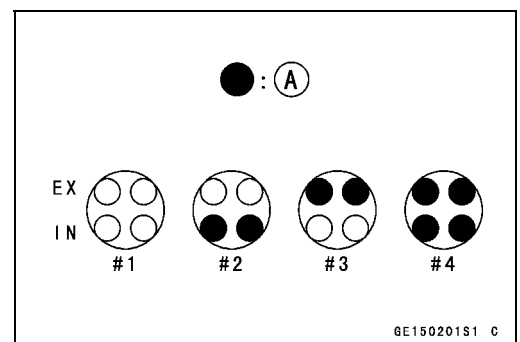

- When positioning #1 piston TDC at the end of the compression stroke:

Inlet valve clearance of #1 and #3 cylinders
 Exhaust valve clearance of #1 and #2 cylinders
 Measuring Valve [A]

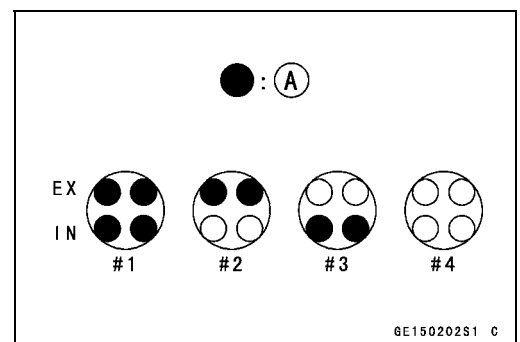

- ★ If the valve clearance is not within the specified range, first record the clearance, and then adjust it.

4-20 ENGINE TOP END

Valves

Valve Clearance Adjustment

- To change the valve clearance, remove the camshaft chain tensioner, camshafts and valve lifters. Replace the shim with one of a different thickness.

NOTE

○ *Mark and record the valve lifter and shim locations so they can be reinstalled in their original positions.*

○ *If there is no clearance, select a shim which is several sizes smaller and then measure the clearance.*

- To select a new shim which brings the valve clearance within the specified range, refer to the Valve Clearance Adjustment Charts.
- Apply a thin coat of molybdenum disulfide grease to the valve lifters.
- Install the camshafts. Be sure to time the camshafts properly (see Camshaft Installation).
- Remeasure any valve clearance that was adjusted. Readjust if necessary.

CAUTION
Do not put shim stock under the shim. This may cause the shim to pop out at high rpm, causing extensive engine damage.
Do not grind the shim. This may cause it to fracture, causing extensive engine damage.

Valves

VALVE CLEARANCE ADJUSTMENT CHART INLET VALVE

		PRESENT SHIM																				
												Example										
PART No. (92180 -)		1014	1016	1018	1020	1022	1024	1028	1028	1030	1032	1034	1036	1038	1040	1042	1044	1046	1048	1050	1052	1054
MARK		50	55	60	65	70	75	80	85	90	95	00	05	10	15	20	25	30	35	40	45	50
THICKNESS (mm)		2.50	2.55	2.60	2.65	2.70	2.75	2.80	2.85	2.90	2.95	3.00	3.05	3.10	3.15	3.20	3.25	3.30	3.35	3.40	3.45	3.50
VALVE CLEARANCE MEASUREMENT	Example	0.00 ~ 0.05																				
	0.06 ~ 0.10																					
	0.11 ~ 0.19																					
	0.20 ~ 0.24																					
	0.25 ~ 0.29																					
	0.30 ~ 0.34																					
	0.35 ~ 0.39																					
	0.40 ~ 0.44																					
	0.45 ~ 0.49																					
	0.50 ~ 0.54																					
	0.55 ~ 0.59																					
	0.60 ~ 0.64																					
	0.65 ~ 0.69																					
	0.70 ~ 0.74																					
	0.75 ~ 0.79																					
	0.80 ~ 0.84																					
0.85 ~ 0.89																						
0.90 ~ 0.94																						
0.95 ~ 0.99																						
1.00 ~ 1.04																						
1.05 ~ 1.09																						
1.10 ~ 1.14																						
1.15 ~ 1.19																						

1. Measure the clearance (when engine is cold).
2. Check present shim size.
3. Match clearance in vertical column with present shim size in horizontal column.
4. Install the shim specified where the lines intersect. This shim will give the proper clearance.

Example: Present shim is **3.05 mm (0.120 in.)**.
 Measured clearance is **0.35 mm (0.014 in.)**.
 Replace **3.05 mm (0.120 in.)** shim with **3.25 mm (0.128 in.)** shim.
5. Remeasure the valve clearance and readjust if necessary.

4-22 ENGINE TOP END

Valves

VALVE CLEARANCE ADJUSTMENT CHART EXHAUST VALVE

		PRESENT SHIM																		Example			
PART No. (92180 -)		1014	1018	1018	1020	1022	1024	1026	1028	1030	1032	1034	1036	1038	1040	1042	1044	1046	1048	1050	1052	1054	
MARK		50	55	60	65	70	75	80	85	90	95	00	05	10	15	20	25	30	35	40	45	50	
THICKNESS (mm)		2.50	2.55	2.60	2.65	2.70	2.75	2.80	2.85	2.90	2.95	3.00	3.05	3.10	3.15	3.20	3.25	3.30	3.35	3.40	3.45	3.50	
VALVE CLEARANCE MEASUREMENT	Example 0.00 ~ 0.02	SPECIFIED CLEARANCE/NO CHANGE REQUIRED																					
	0.03 ~ 0.06						2.50	2.55	2.60	2.65	2.70	2.75	2.80	2.85	2.90	2.95	3.00	3.05	3.10	3.15	3.20	3.25	
	0.07 ~ 0.11				2.50	2.55	2.60	2.65	2.70	2.75	2.80	2.85	2.90	2.95	3.00	3.05	3.10	3.15	3.20	3.25	3.30	3.35	
	0.12 ~ 0.16			2.50	2.55	2.60	2.65	2.70	2.75	2.80	2.85	2.90	2.95	3.00	3.05	3.10	3.15	3.20	3.25	3.30	3.35	3.40	
	0.17 ~ 0.21		2.50	2.55	2.60	2.65	2.70	2.75	2.80	2.85	2.90	2.95	3.00	3.05	3.10	3.15	3.20	3.25	3.30	3.35	3.40	3.45	
	0.22 ~ 0.31																						
	0.32 ~ 0.36	2.55	2.60	2.65	2.70	2.75	2.80	2.85	2.90	2.95	3.00	3.05	3.10	3.15	3.20	3.25	3.30	3.35	3.40	3.45	3.50		
	0.37 ~ 0.41	2.60	2.65	2.70	2.75	2.80	2.85	2.90	2.95	3.00	3.05	3.10	3.15	3.20	3.25	3.30	3.35	3.40	3.45	3.50			
	0.42 ~ 0.46	2.65	2.70	2.75	2.80	2.85	2.90	2.95	3.00	3.05	3.10	3.15	3.20	3.25	3.30	3.35	3.40	3.45	3.50				
	0.47 ~ 0.51	2.70	2.75	2.80	2.85	2.90	2.95	3.00	3.05	3.10	3.15	3.20	3.25	3.30	3.35	3.40	3.45	3.50					
	0.52 ~ 0.56	2.75	2.80	2.85	2.90	2.95	3.00	3.05	3.10	3.15	3.20	3.25	3.30	3.35	3.40	3.45	3.50						
	0.57 ~ 0.61	2.80	2.85	2.90	2.95	3.00	3.05	3.10	3.15	3.20	3.25	3.30	3.35	3.40	3.45	3.50							
	0.62 ~ 0.66	2.85	2.90	2.95	3.00	3.05	3.10	3.15	3.20	3.25	3.30	3.35	3.40	3.45	3.50								
	0.67 ~ 0.71	2.90	2.95	3.00	3.05	3.10	3.15	3.20	3.25	3.30	3.35	3.40	3.45	3.50									
	0.72 ~ 0.76	2.95	3.00	3.05	3.10	3.15	3.20	3.25	3.30	3.35	3.40	3.45	3.50										
	0.77 ~ 0.81	3.00	3.05	3.10	3.15	3.20	3.25	3.30	3.35	3.40	3.45	3.50											
	0.82 ~ 0.86	3.05	3.10	3.15	3.20	3.25	3.30	3.35	3.40	3.45	3.50												
	0.87 ~ 0.91	3.10	3.15	3.20	3.25	3.30	3.35	3.40	3.45	3.50													
	0.92 ~ 0.96	3.15	3.20	3.25	3.30	3.35	3.40	3.45	3.50														
	0.97 ~ 1.01	3.20	3.25	3.30	3.35	3.40	3.45	3.50															
1.02 ~ 1.06	3.25	3.30	3.35	3.40	3.45	3.50																	
1.07 ~ 1.11	3.30	3.35	3.40	3.45	3.50																		
1.12 ~ 1.16	3.35	3.40	3.45	3.50																			
1.17 ~ 1.21	3.40	3.45	3.50																				
1.22 ~ 1.26	3.45	3.50																					
1.27 ~ 1.31	3.50																						

1. Measure the clearance (when engine is cold).
2. Check present shim size.
3. Match clearance in vertical column with present shim size in horizontal column.
4. Install the shim specified where the lines intersect. This shim will give the proper clearance.

Example: Present shim is **3.10 mm (0.122 in.)**.
 Measured clearance is **0.40 mm (0.016 in.)**.
 Replace **3.10 mm (0.122 in.)** shim with **3.2 mm (0.126 in.)** shim.
5. Remeasure the valve clearance and readjust if necessary.

Valves

Valve Removal

- Remove the cylinder head (see Cylinder Head Removal).
- Remove the valve lifter and shim.
- Mark and record the valve lifter and shim locations so they can be installed in their original positions.
- Using the valve spring compressor assembly, remove the valve.

Special Tools - Valve Spring Compressor Assembly: 57001-241 [A]

Valve Spring Compressor Adapter, ϕ 22: 57001-1202 [B]

Valve Spring Compressor Adapter, ϕ 20: 57001-1154

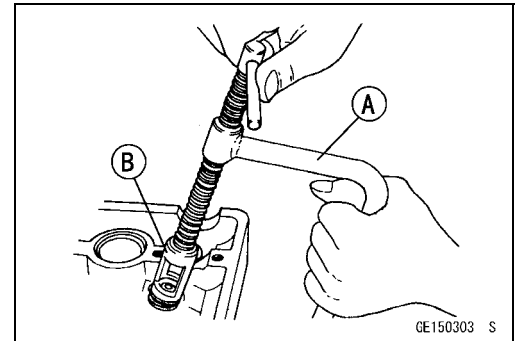

Valve Installation

- Replace the oil seal with a new one.
- Apply a thin coat of molybdenum disulfide grease to the valve stem before valve installation.
- Install the springs so that the closed coil end faces downwards.

[B] Valve Stem

[C] Oil Seal

[D] Spring Seat

[E] Closed Coil End

[F] Exhaust Valve Springs

[G] Retainer

[H] Split Keepers

- Dual springs [A] are used for the inlet valve.

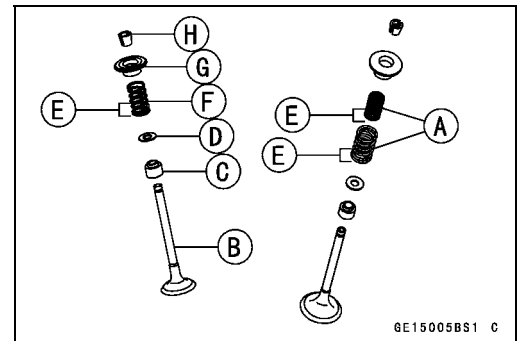

Valve Guide Removal

- Remove:
 - Valve (see Valve Removal)
 - Oil Seal
 - Spring Seat
- Heat the area around the valve guide to 120 ~ 150°C (248 ~ 302 °F), and hammer lightly on the valve guide arbor [A] to remove the guide from the top of the head.

CAUTION

Do not heat the cylinder head with a torch. This will warp the cylinder head. Soak the cylinder head in oil and heat the oil.

Special Tool - Valve Guide Arbor, ϕ 4: 57001-1273

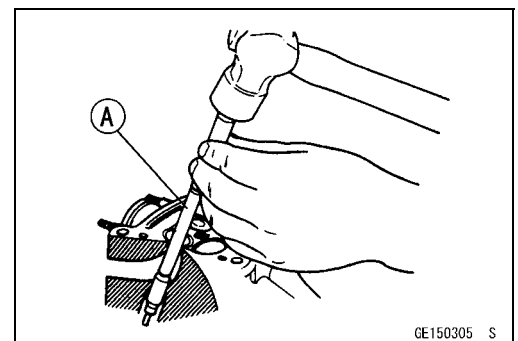

4-24 ENGINE TOP END

Valves

Valve Guide Installation

- Apply oil to the valve guide outer surface before installation.
- Heat the area around the valve guide hole to about 120 ~ 150 °C (248 ~ 302 °F).
- Drive the valve guide in from the top of the head using the valve guide arbor. The flange stops the guide from going in too far.

Special Tool - Valve Guide Arbor, $\phi 4$: 57001-1273

- Wait until the cylinder head cools down and then ream the valve guide with the valve guide reamer [A] even if the old guide is reused.
- Turn the reamer in a clockwise direction until the reamer turns freely in the guide. Never turn the reamer counter-clockwise or it will be dulled.
- Once the guides are reamed they must be cleaned thoroughly.

Special Tool - Valve Guide Reamer, $\phi 4$: 57001-1274

Valve-to-Guide Clearance Measurement (Wobble Method)

If a small bore gauge is not available, inspect the valve guide wear by measuring the valve to valve guide clearance with the wobble method as indicated below.

- Insert a new valve [A] into the guide [B] and set a dial gauge against the stem perpendicular to it as close as possible to the cylinder head mating surface.
- Move the stem back and forth [C] to measure valve/valve guide clearance.
- Repeat the measurement in a direction at a right angle to the first.
- ★ If the reading exceeds the service limit, replace the guide.

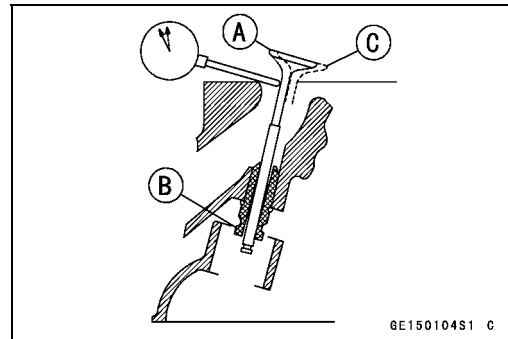
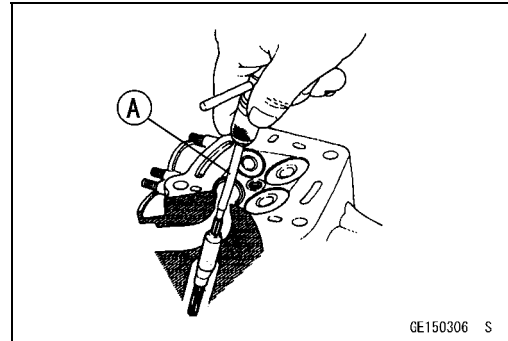

NOTE

- The reading is not actual valve/valve guide clearance because the measuring point is above the guide.

Valve/Valve Guide Clearance (Wobble Method)

Standard:

Inlet	0.03 ~ 0.12 mm (0.0012 ~ 0.0047 in.)
Exhaust	0.10 ~ 0.18 mm (0.004 ~ 0.007 in.)

Service Limit:

Inlet	0.29 mm (0.011 in.)
Exhaust	0.35 mm (0.014 in.)

Valves

Valve Seat Inspection

- Remove the valve (see Valve Removal).
- Check the valve seating surface [A] between the valve [B] and valve seat [C].
- Measure the outside diameter [D] of the seating pattern on the valve seat.
- ★ If the outside diameter is too large or too small, repair the seat (see Seat Repair).

Valve Seating Surface Outside Diameter

Standard:

Inlet	26.4 ~ 26.6 mm (1.039 ~ 1.047 in.)
Exhaust	22.1 ~ 22.3 mm (0.870 ~ 0.878 in.)

- Measure the seat width [E] of the portion where there is no build-up carbon (white portion) of the valve seat with a vernier caliper.

Good [F]

- ★ If the width is too wide [G], too narrow [H] or uneven [J], repair the seat (see Valve Seat Repair).

Valve Seating Surface Width

Standard:

Inlet, Exhaust	0.5 ~ 1.0 mm (0.02 ~ 0.04 in.)
----------------	--------------------------------

Valve Seat Repair

- Repair the valve seat with the valve seat cutters [A].

Special Tool - Valve Seat Cutter Holder, $\phi 4$: 57001-1275

[B]

Valve Seat Cutter Holder Bar: 57001-1128

[C]

[For Inlet Valve Seat]

Valve Seat Cutter, 45° - $\phi 27.5$: 57001-1114

Valve Seat Cutter, 32° - $\phi 28$: 57001-1119

Valve Seat Cutter, 60° - $\phi 30$: 57001-1123

[For Exhaust Valve Seat]

Valve Seat Cutter, 45° - $\phi 32$: 57001-1115

Valve Seat Cutter, 32° - $\phi 30$: 57001-1120

Valve Seat Cutter, 60° - $\phi 33$: 57001-1334

- ★ If the manufacturer's instructions are not available, use the following procedure.

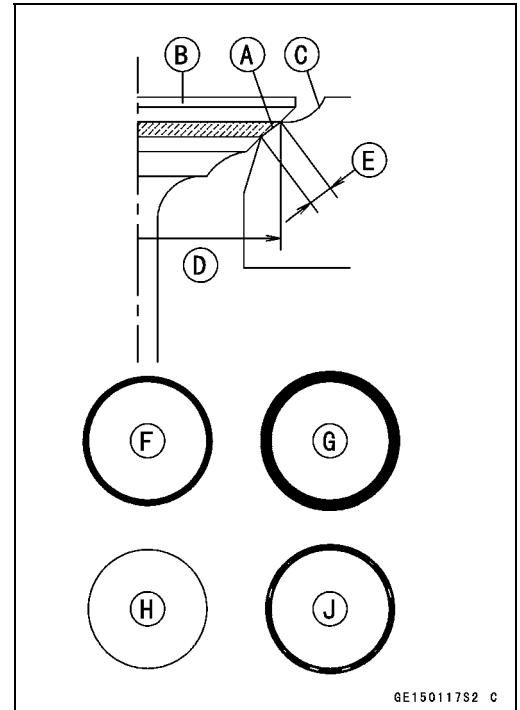

GE150117S2 C

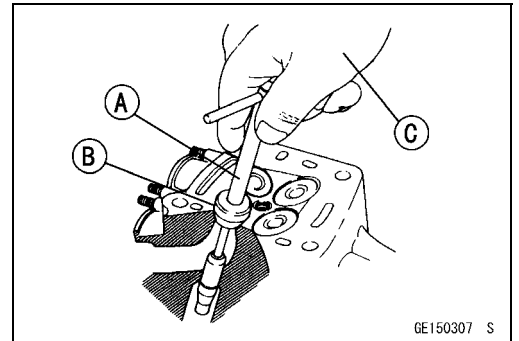

GE150307 S

4-26 ENGINE TOP END

Valves

Seat Cutter Operation Care

1. This valve seat cutter is developed to grind the valve for repair. Therefore the cutter must not be used for other purposes than seat repair.
2. Do not drop or shock the valve seat cutter, or the diamond particles may fall off.
3. Do not fail to apply engine oil to the valve seat cutter before grinding the seat surface. Also wash off ground particles sticking to the cutter with washing oil.

NOTE

○Do not use a wire brush to remove the metal particles from the cutter. It will take off the diamond particles.

4. Setting the valve seat cutter holder in position, operate the cutter in one hand. Do not apply too much force to the diamond portion.

NOTE

○Prior to grinding, apply engine oil to the cutter and during the operation, wash off any ground particles sticking to the cutter with washing oil.

5. After use, wash it with washing oil and apply thin layer of engine oil before storing.

Marks Stamped on the Cutter

The marks stamped on the back of the cutter [A] represent the following.

- 60° Cutter angle [B]
- 37.5φ Outer diameter of cutter [C]

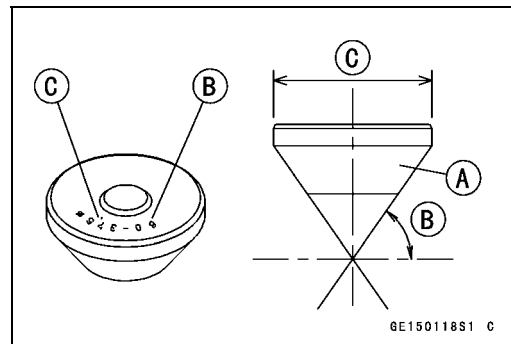

Operating Procedures

- Clean the seat area carefully.
- Coat the seat with machinist's dye.
- Fit a 45° cutter into the holder and slide it into the valve guide.
- Press down lightly on the handle and turn it right or left. Grind the seating surface only until it is smooth.

CAUTION

Do not grind the seat too much. Overgrinding will reduce valve clearance by sinking the valve into the head. If the valve sinks too far into the head, it will be impossible to adjust the clearance, and the cylinder head must be replaced.

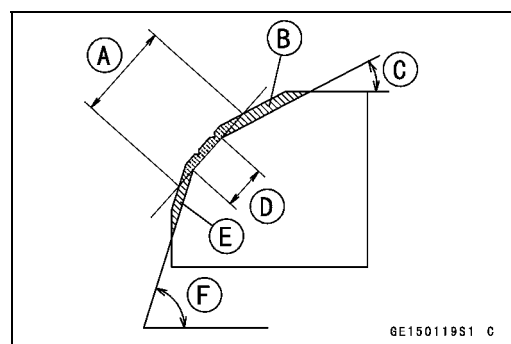

- Widened Width [A] of engagement by machining with 45° cutter
- Ground Volume [B] by 32° cutter
- 32° [C]
- Correct Width [D]
- Ground Volume [E] by 60° cutter
- 60° [F]

Valves

- Measure the outside diameter of the seating surface with a vernier caliper.
- ★ If the outside diameter of the seating surface is too small, repeat the 45° grind [A] until the diameter is within the specified range.

Original Seating Surface [B]

NOTE

- Remove all pittings or flaws from 45° ground surface.
- After grinding with 45° cutter, apply thin coat of machinist's dye to seating surface. This makes seating surface distinct and 32° and 60° grinding operation easier.
- When the valve guide is replaced, be sure to grind with 45° cutter for centering and good contact.

- ★ If the outside diameter of the seating surface is too large, make the 32° grind described below.
- ★ If the outside diameter [A] of the seating surface is within the specified range, measure the seat width as described below.
- Grind the seat at a 32° angle [B] until the seat outside diameter is within the specified range.
- To make the 32° grind, fit a 32° cutter into the holder, and slide it into the valve guide.
- Turn the holder one turn at a time while pressing down very lightly. Check the seat after each turn.

CAUTION

The 32° cutter removes material very quickly. Check the seat outside diameter frequently to prevent overgrinding.

- After making the 32° grind, return to the seat outside diameter measurement step above.
 - To measure the seat width, use a vernier caliper to measure the width of the 45° angle portion of the seat at several places around the seat.
 - ★ If the seat width is too narrow, repeat the 45° grind until the seat is slightly too wide, and then return to the seat outside diameter measurement step above.
 - ★ If the seat width is too wide, make the 60° [A] grind described below.
 - ★ If the seat width is within the specified range, lap the valve to the seat as described below.
 - Grind the seat at a 60° angle until the seat width is within the specified range.
 - To make the 60° grind, fit 60° cutter into the holder, and slide it into the valve guide.
 - Turn the holder, while pressing down lightly.
 - After making the 60° grind, return to the seat width measurement step above.
- Correct Width [B]

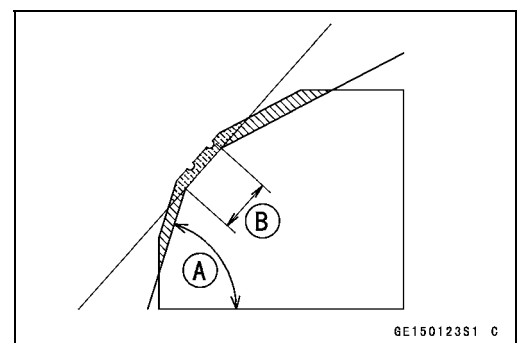
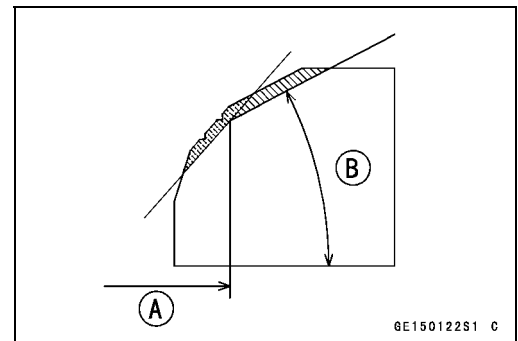
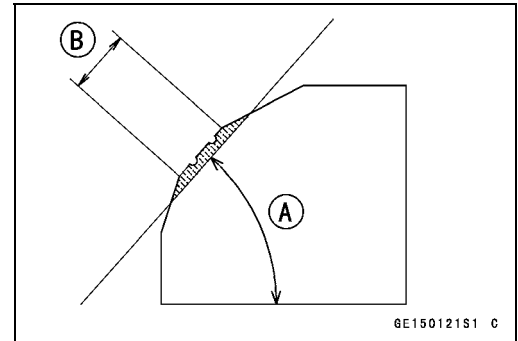

4-28 ENGINE TOP END

Valves

- Lap the valve to the seat, once the seat width and outside diameter are within the ranges specified above.
- Put a little coarse grinding compound on the face of the valve in a number of places around the valve head.
- Spin the valve against the seat until the grinding compound produces a smooth, matched surface on both the seat and the valve.
- Repeat the process with a fine grinding compound.
 - [A] Lapper
 - [B] Valve Seat
 - [C] Valve
- The seating area should be marked about in the middle of the valve face.
- ★ If the seat area is not in the right place on the valve, check to be sure the valve is the correct part. If it is, it may have been refaced too much; replace it.
- Be sure to remove all grinding compound before assembly.
- When the engine is assembled, be sure to adjust the valve clearance (see Valve Clearance Adjustment).

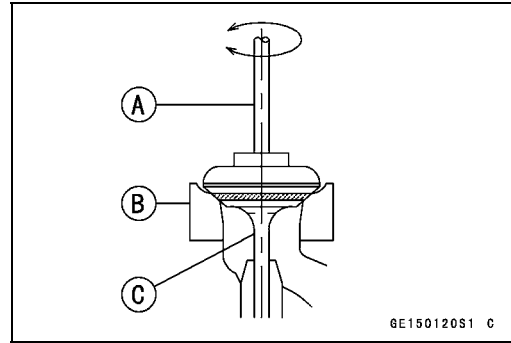

Valves

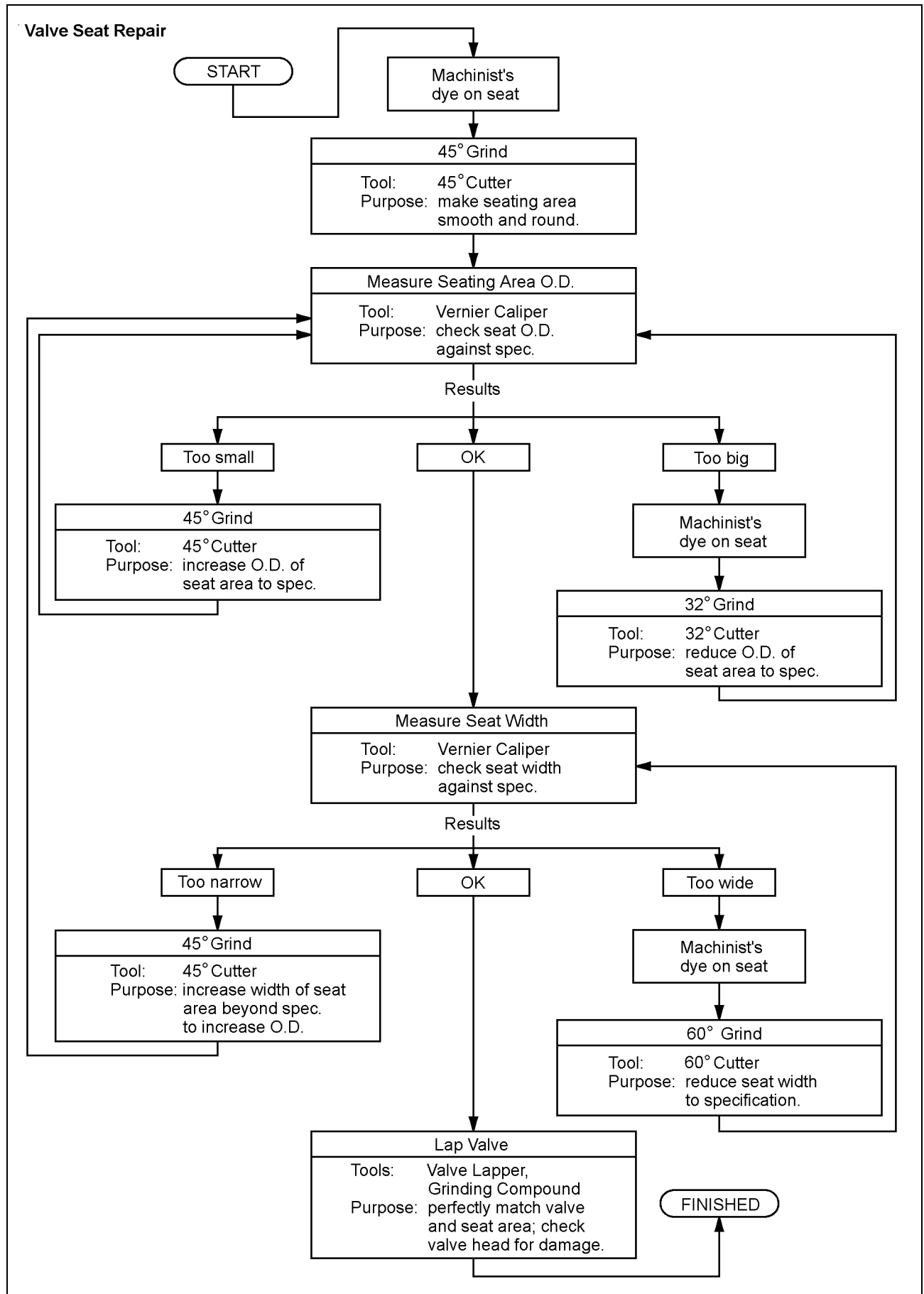

4-30 ENGINE TOP END

Cylinder, Pistons

Cylinder Removal

- Remove:
 - Engine (see Engine Removal/Installation chapter)
 - Cylinder Head (see Cylinder Head Removal)
 - Water Hoses [A]
 - Rear Camshaft Chain Guide and Bolt
- Remove the cylinder.

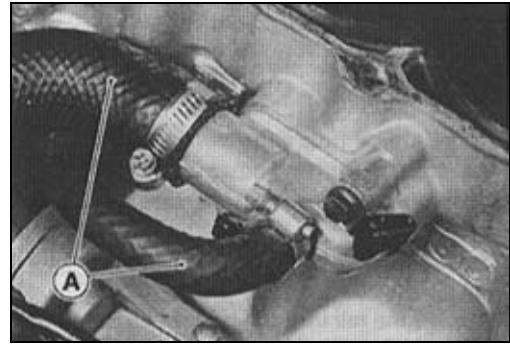

Cylinder Installation

NOTE

○ If a new cylinder is used, use new piston ring.

- Install the pins [A] and new cylinder gasket.
 - Apply engine oil to the cylinder bore.
 - Prepare two auxiliary head bolts with their head cut.
 - Install the two bolts [B] diagonally in the crankcase.
-
- The piston ring openings must be positioned as shown in the figure. The openings of the oil ring steel rails must be about 30-40° of angle from the opening of the top ring.
 - [A] Top Ring
 - [B] Second Ring
 - [C] Oil Ring Steel Rails
 - [D] Oil Ring Expander
 - [E] Hollow
-
- Position the crankshaft so that all the piston heads are almost level.
 - Install the cylinder block [A].
 - Auxiliary Head Bolts [B]
 - Pistons [C]
 - Insert the piston rings with your thumbs.

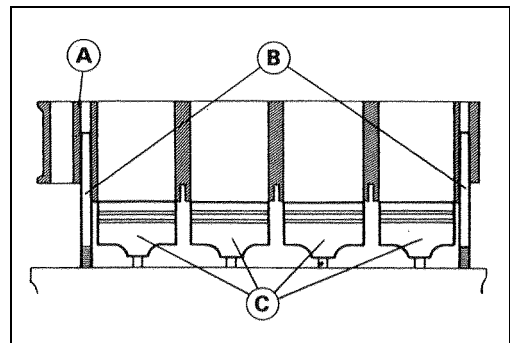
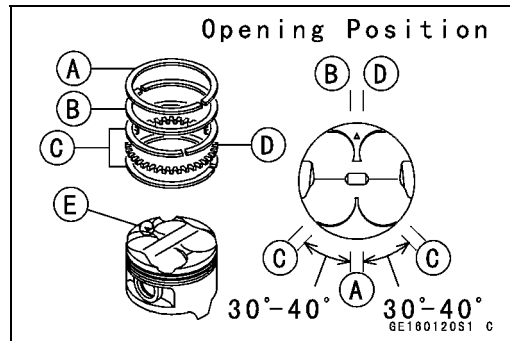
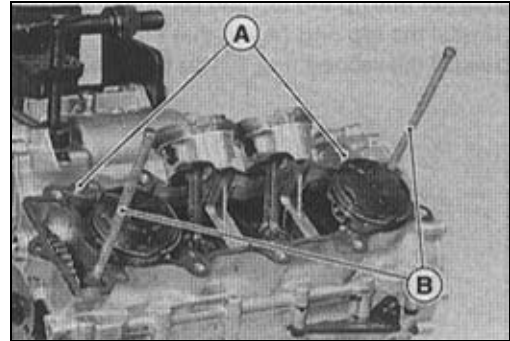

Piston Removal

- Remove the cylinder (see Cylinder Removal).
- Place a clean cloth under the pistons and remove the piston pin snap ring [A] from the outside of each piston.



Cylinder, Pistons

- Remove the piston pins.

Special Tool - Piston Pin Puller Assembly: 57001-910 [A]

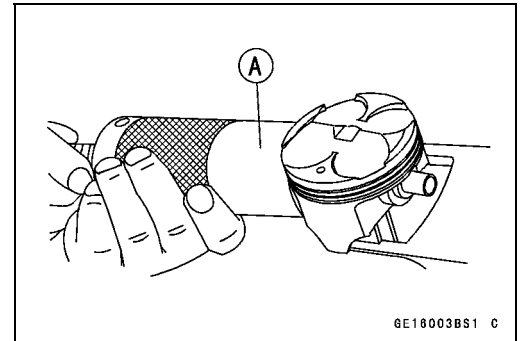

- Carefully spread the ring opening with your thumbs and then push up on the opposite side of the ring [A] to remove it.
- Remove the 3-piece oil ring with your thumbs in the same manner.

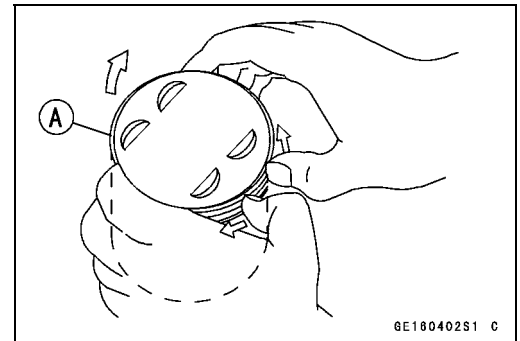

Piston Installation

NOTE

○If a new piston is used, use new piston ring.

- Install the piston with its marking hollow facing forward.
 - Fit a new piston pin snap ring into the side of the piston so that the ring opening [A] does not coincide with the slit [B] of the piston pin hole.
- When installing the piston pin snap ring, compress it only enough to install it and no more.

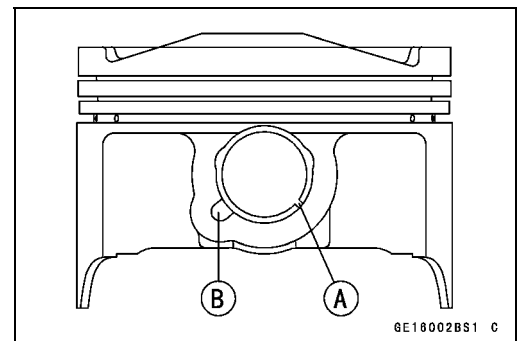

CAUTION

**Do not reuse snap rings, as removal weakens and deforms them.
They could fall out and score the cylinder wall.**

- Install the oil ring expander [A] in the bottom piston ring groove so the ends [B] butt together.
 - Install the oil ring steel rails, one above the expander and one below it.
- Spread the rail with your thumbs, but only enough to fit the rail over the piston.
- Release the rail into the bottom piston ring groove.

NOTE

○The oil ring rails have no "top" or "bottom".

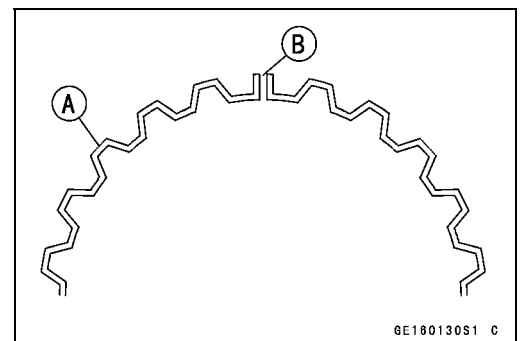

4-32 ENGINE TOP END

Cylinder, Pistons

- Do not mix up the top and second ring.
- Install the top ring [A] so that the "R" mark [B] faces up.
- Install the second ring [C] so that the "RN" mark [D] faces up.

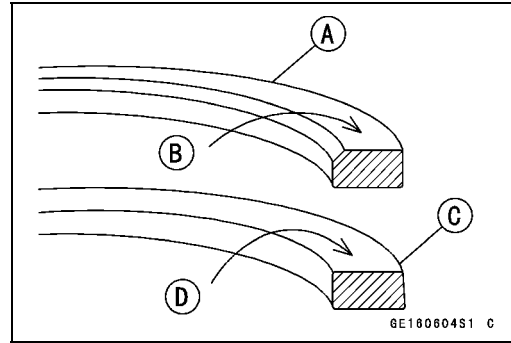

Cylinder Wear Inspection

- Since there is a difference in cylinder wear in different directions, take a side-to-side and a front-to-back measurement at each of the two locations (total of four measurements) shown in the figure.
- ★ If any of the cylinder inside diameter measurements exceeds the service limit, replace the cylinder.
 - [A] 10 mm (0.39 in.)
 - [B] 60 mm (2.36 in.)

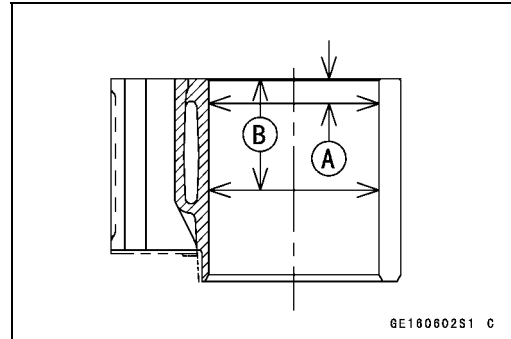

Cylinder Inside Diameter

Standard: 65.960 ~ 65.972 mm (2.5968 ~ 2.5973 in.)
Service Limit: 66.06 mm (2.601 in.)

Piston Wear Inspection

- Measure the outside diameter [A] of each piston 5 mm (0.20 in.) [B] up from the bottom of the piston at a right angle to the direction of the piston pin.
- ★ If the measurement is under service limit, replace the piston.

Piston Diameter

Standard: 65.935 ~ 65.950 mm (2.5957 ~ 2.5965 in.)
Service Limit: 65.78 mm (2.590 in.)

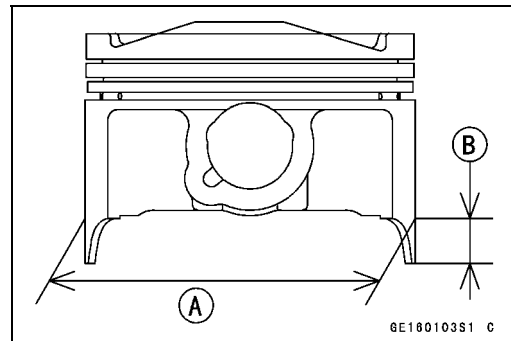

Piston Ring, Piston Ring Groove Wear Inspection

- Check for uneven groove wear by inspecting the ring seating.
- ★ The rings should fit perfectly parallel to groove surfaces. If not, replace the piston and all the piston rings.
- With the piston rings in their grooves, make several measurements with a thickness gauge [A] to determine piston ring/groove clearance.

Piston Ring/Groove Clearance

Standard:

Top	0.05 ~ 0.09 mm (0.0020 ~ 0.0035 in.)
Second	0.03 ~ 0.07 mm (0.0012 ~ 0.0028 in.)

Service Limit:

Top	0.19 mm (0.0075 in.)
Second	0.17 mm (0.0067 in.)

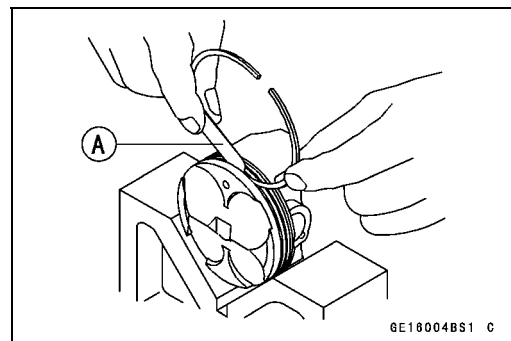

Cylinder, Pistons

Piston Ring Groove Width Inspection

- Measure the piston ring groove width.
- Use a vernier caliper at several points around the piston.

Piston Ring/Groove Width

Standard:

Top	0.84 ~ 0.86 mm (0.0331 ~ 0.0339 in.)
Second	0.82 ~ 0.84 mm (0.0323 ~ 0.0331 in.)

Service Limit:

Top	0.94 mm (0.037 in.)
Second	0.92 mm (0.036 in.)

- ★ If the width of any of the two grooves is wider than the service limit at any point, replace the piston.

Piston Ring Thickness Inspection

- Measure the piston ring thickness.
- Use the micrometer to measure at several points around the ring.

Piston Ring Thickness

Standard:

Top	0.77 ~ 0.79 mm (0.0303 ~ 0.0311 in.)
Second	0.77 ~ 0.79 mm (0.0303 ~ 0.0311 in.)

Service Limit:

Top	0.70 mm (0.028 in.)
Second	0.70 mm (0.028 in.)

- ★ If any of the measurements is less than the service limit on either of the rings, replace all the rings.

NOTE

- When using new rings in a used piston, check for uneven groove wear. The rings should fit perfectly parallel to the groove sides. If not, replace the piston.

Piston Ring End Gap Inspection

- Place the piston ring [A] inside the cylinder, using the piston to locate the ring squarely in place. Set it close to the bottom of the cylinder, where cylinder wear is low.
- Measure the gap [B] between the ends of the ring with a thickness gauge.

Piston Ring End Gap

Standard:

Top	0.15 ~ 0.3 mm (0.0059 ~ 0.0118 in.)
Second	0.30 ~ 0.45 mm (0.0118 ~ 0.0177 in.)

Service Limit:

Top	0.6 mm (0.024 in.)
Second	0.8 mm (0.031 in.)

- ★ If the end gap of either ring is greater than the service limit, replace all the rings.

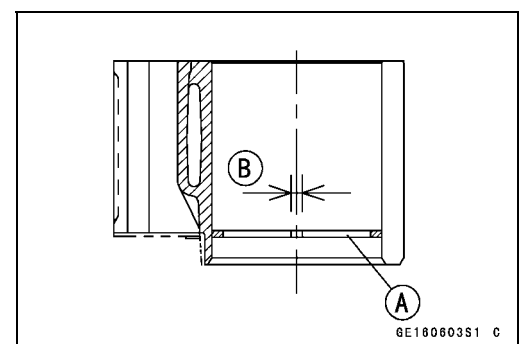

4-34 ENGINE TOP END

Carburetor Holder

Carburetor Holder Installation

- Be sure to install the O-rings [A].
- Tighten the carburetor holder bolts [B].
- Tighten the #1,3 right carburetor holder bolts with clamp [C] (use of clamps for California Model only).

Torque - Carburetor Holder Bolts: 12 N·m (1.2 kgf·m, 104 in·lb)

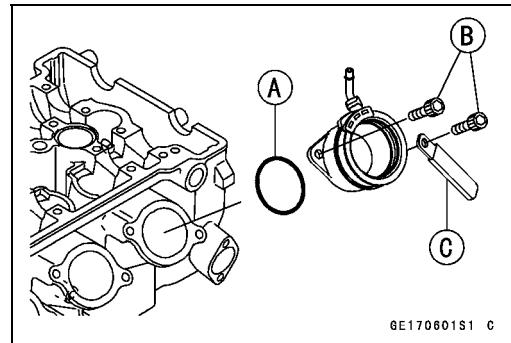

Muffler

⚠ WARNING

To avoid a serious burn, do not remove the mufflers when the engine is still hot. Wait until the mufflers cool down.

Muffler and Exhaust Pipe Removal

- Remove:
 - Lower Fairings (see Frame chapter)
 - Exhaust Pipe Mounting Bolt [A]

- Remove the muffler mounting nut [A].

- Remove the radiator mount bolt [A].
- Loosen the radiator bolts [B].
- Move the bottom of the radiator toward the front [C], and then tighten the radiator bolts [B].
- Remove:
 - Exhaust Pipe Holder Nuts [D]
- Pull the muffler mounting bolt and remove the muffler assembly.
- When removing the exhaust pipe holder, don't hit the radiator.

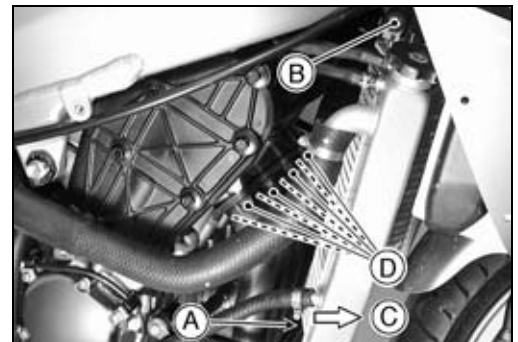
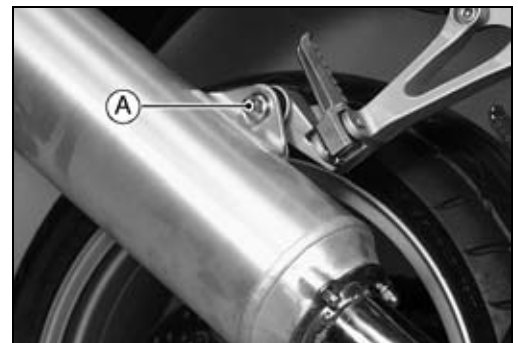

Muffler and Exhaust Pipe Installation

- Replace the exhaust pipe holder gaskets with new ones.
- Thoroughly warm up the engine, wait until the engine cools down, and retighten all the bolts and nuts.
- Tighten the exhaust pipe holder nuts.
- Tighten:
 - Torque - Exhaust Pipe Mounting Bolt: 34 N·m (3.5 kgf·m, 25 ft·lb)**

4-36 ENGINE TOP END

Muffler

Muffler Body Removal

- Remove:
 - Exhaust Pipe Connecting Nuts [A]
 - Muffler Mounting Bolt, Nut [B] and Washer
- Pull the muffler body [C] backward.

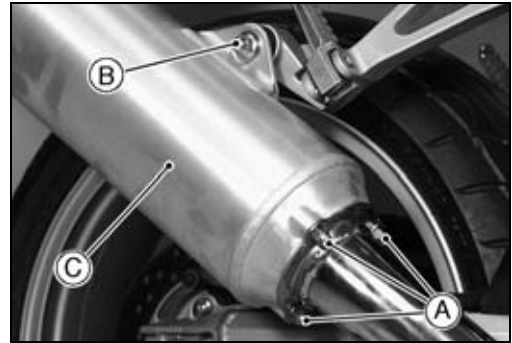

Muffler Body Installation

- Replacing the muffler body gasket with new one.
- Tighten:
 - Torque - Muffler Body and Exhaust Pipe Connecting Nuts:**
45 N·m (4.5 kgf·m, 33 ft·lb)
- Thoroughly warm up the engine, wait until the engine cools down, and retighten all the bolts and nuts.

Clutch

Table of Contents

Exploded View	5-2
Specifications	5-3
Clutch Lever and Cable	5-4
Clutch Lever Free Play Inspection	5-4
Clutch Lever Free Play Adjustment	5-4
Clutch Cable Removal	5-5
Clutch Cable Installation	5-5
Clutch Cable Lubrication	5-5
Clutch Lever Installation	5-5
Clutch Cover	5-6
Clutch Cover Removal	5-6
Clutch Cover Installation	5-6
Clutch Release Shaft Removal	5-6
Clutch Release Shaft Installation	5-6
Clutch	5-7
Clutch Removal	5-7
Clutch Installation	5-7
Clutch Plate Assembly Inspection	5-9
Clutch Plate Assembly Adjustment	5-10
Clutch Plate Wear, Damage Inspection	5-10
Clutch Plate Warp Inspection	5-10
Clutch Spring Free Length Measurement	5-11

Specifications

Item	Standard	Service Limit
Clutch Lever Free Play	2 ~ 3 mm (0.08 ~ 0.12 in.)	- - -
Clutch		
Friction Plate Thickness	2.72 ~ 2.88 mm (0.107 ~ 0.113 in.)	2.2 mm (0.087 in.)
Friction and Steel Plate Warp	0.2 mm (0.008 in.) or less	0.3 mm (0.012 in.)
Clutch Spring Free Length	82.1 mm (3.23 in.)	78.0 mm (3.07 in.)
Clutch Plate Assembly Length	37.7 ~ 38.3 mm (1.48 ~ 1.51 in.)	- - -

Special Tool - Clutch Holder: 57001-1243

Sealant - Kawasaki Bond (Silicone Sealant): 56019-120

5-4 CLUTCH

Clutch Lever and Cable

Clutch Lever Free Play Inspection

- Pull the clutch lever just enough to take up the free play [A].
- Measure the gap between the lever and the lever holder.
- ★ If the gap is too wide, the clutch may not release fully. If the gap is too narrow, the clutch may not engage fully. In either case, adjust it.

Clutch Lever Free Play

Standard: 2 ~ 3 mm (0.08 ~ 0.12 in.)

Clutch Lever Free Play Adjustment

⚠ WARNING

To avoid a serious burn, never touch the engine or exhaust pipe during clutch adjustment.

- Turn the adjuster [A] so that 5 ~ 6 mm (0.20 ~ 0.24 in.) [B] of threads are visible.
- Slide the dust cover [A] at the clutch cable lower end out of place.
- Loosen both adjusting nuts [B] at the clutch cover as far as they will go.
- Pull the clutch outer cable [C] tight and tighten the adjusting nuts against the bracket [D].
- Slip the rubber dust cover back onto place.
- Turn the adjuster at the clutch lever until the free play is correct.
- Push the release lever [A] toward the front of the motorcycle until it becomes hard to turn.
- At this time, the release lever should have the proper angle shown.
- ★ If the angle is wrong, check the clutch and release parts for wear.

⚠ WARNING

Be sure that the outer cable end at the clutch lever is fully seated in the adjuster at the clutch lever, or it could slip into place later, creating enough cable play to prevent clutch disengagement.

- After the adjustment, start the engine and check that the clutch does not slip and that it releases properly.

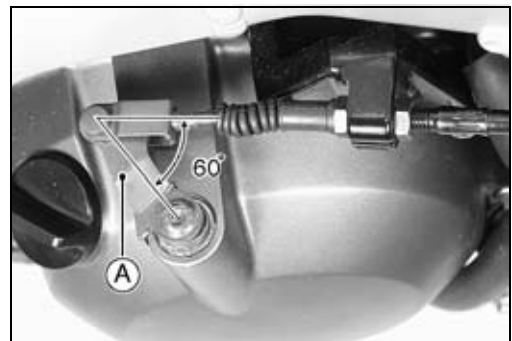
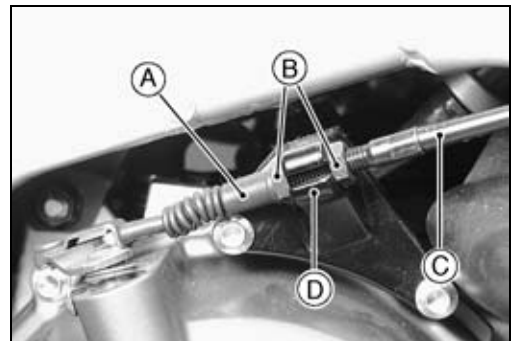

Clutch Lever and Cable

Clutch Cable Removal

- Remove the right lower fairing (see frame chapter).
- Slide the dust cover at the clutch cable lower end out of place.
- Loosen the nuts, and slide the lower end of the clutch cable to give the cable plenty of play.
- Screw in the adjuster.
- Line up the slots [A] in the clutch lever, and adjuster [B], and then free the cable from the lever.
- Free the clutch inner cable tip from the clutch release lever.
- Push the release lever toward the front of the motorcycle and tape the release lever to the clutch cover to prevent the release shaft from falling out.
- Pull the clutch cable out of the frame.



Clutch Cable Installation

- Run the clutch cable correctly (see General Information chapter).
- Adjust the clutch cable (see Lever Free Play Adjustment).

Clutch Cable Lubrication

Whenever the clutch cable is removed, lubricate the clutch cable as follows.

- Apply a thin coating of grease to the cable upper and lower ends.
- Lubricate the cable with a penetrating rust inhibitor.

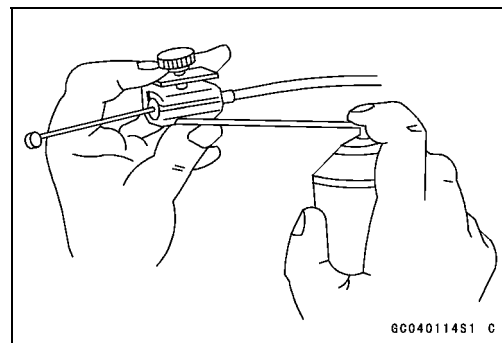

Clutch Lever Installation

- Install the clutch lever so that the mating surface [A] of the switch housing is aligned with the mating surface [B] of the clutch lever clamp.

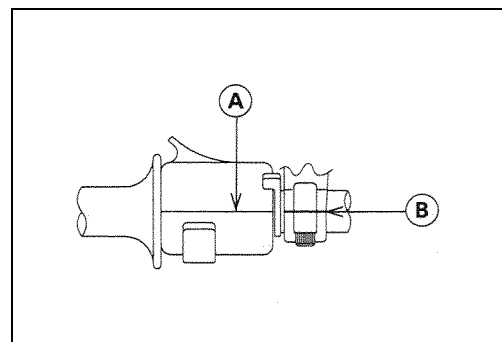

5-6 CLUTCH

Clutch Cover

Clutch Cover Removal

- Remove:
 - Engine Oil (drain, see Engine Lubrication System chapter)
 - Right Lower Fairing (see Frame chapter)
 - Oil Hose
 - Clutch Cable Lower End [A]
 - Clutch Cover Mounting Bolts [B]
- Turn the release lever [A] toward the rear as shown, and remove the clutch cover [B].
[C] about 90°

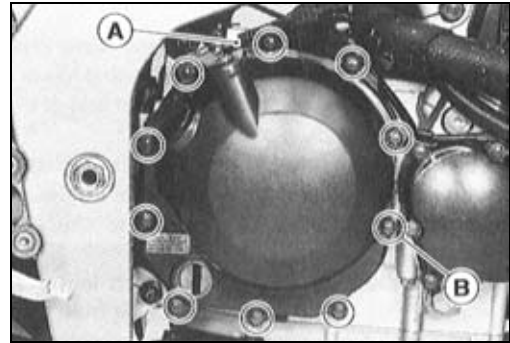

Clutch Cover Installation

- Apply silicone sealant to the area [A] where the mating surface of the crankcase touches the clutch cover gasket.
Sealant - Kawasaki Bond (Silicone Sealant): 56019-120
- Replace the cover gasket with a new one.
- Apply a non-permanent locking agent to the threads of the two clutch cover bolts [B].
- Tighten the cover bolts.
Torque - Clutch Cover Bolts: 12 N·m (1.2 kgf·m, 104 in·lb)

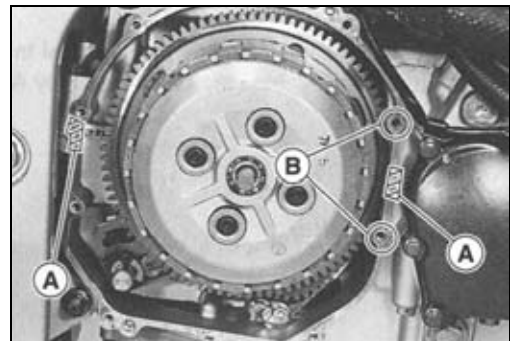

Clutch Release Shaft Removal

CAUTION

Do not remove the clutch release lever and shaft assembly unless it is absolutely necessary. If removed, the oil seal replacement may be required.

- Remove the clutch cover (see Clutch Cover Removal).
- Pull the lever and shaft assembly out of the clutch cover.

Clutch Release Shaft Installation

- Apply high-temperature grease to the oil seal lips on the upper ridge of the clutch cover.
- Apply molybdenum disulfide grease to the clutch release shaft.
- Insert the clutch release shaft straight into the upper hole of the clutch cover.

CAUTION

When inserting the clutch release shaft, be careful not to remove the spring of the oil seal.

Clutch

Clutch Removal

- Remove:
 - Engine Oil (drain, see Engine Lubrication System chapter)
 - Right Lower Fairing (see Frame chapter)
 - Clutch Cover (see Clutch Cover Removal)
 - Clutch Spring Bolts [A]
 - Clutch Springs
 - Clutch Spring Plate [B] (with thrust bearing and pusher [C], spring and washer)

Friction Plates, Steel Plates
 Spring, Spring Seat
 Clutch Hub Nut [A]

- Holding the clutch hub [B], remove the nut.

Special Tool - Clutch Holder: 57001-1243 [C]

- Remove:
 - Clutch Hub

- Using the two 4 mm screws [A], pull out the sleeve [B], needle bearing [C] and clutch housing [D].
- Remove the spacer.

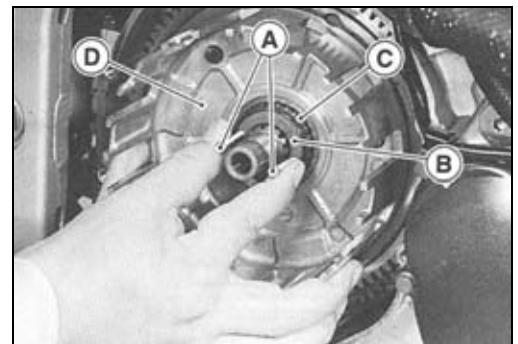
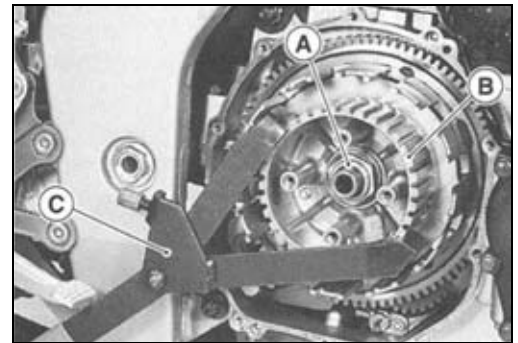
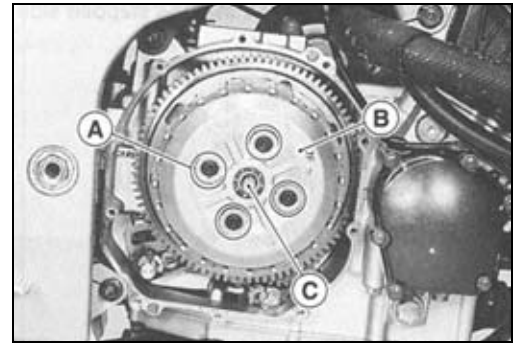

Clutch Installation

- Inspect the clutch plate assembly length (see Clutch Plate Assembly Inspection).
- Install the following parts on the drive shaft.
 - [A] Spacer
 - [B] Sleeve
 - [C] Needle Bearing
 - [D] Clutch Housing
 - [E] Spacer
 - [F] Clutch Hub
 - [G] Washer
 - [H] Nut

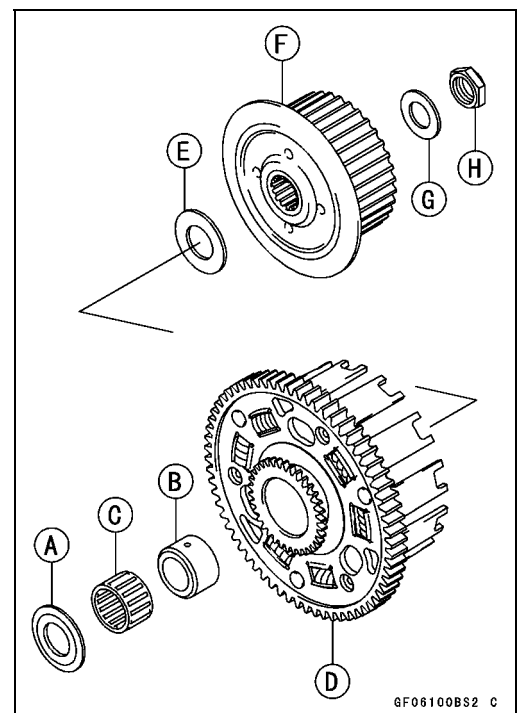

5-8 CLUTCH

Clutch

- Install the spacer [A] so that the stepped side [B] faces inward.

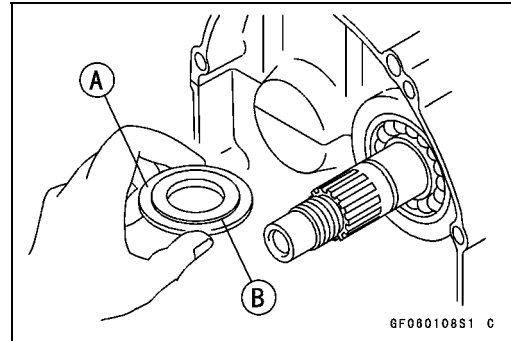

- Install the washer [A] so that the OUT SIDE mark faces outward.



- Replace the clutch hub nut with a new one.
- Holding the clutch hub, tighten the clutch hub nut.
Special Tool - Clutch Holder: 57001-1243
Torque - Clutch Hub Nut: 137 N·m (14 kgf·m, 101 ft·lb)

- Install the spring seat [A] and spring [B] as shown.
[C] Clutch Hub

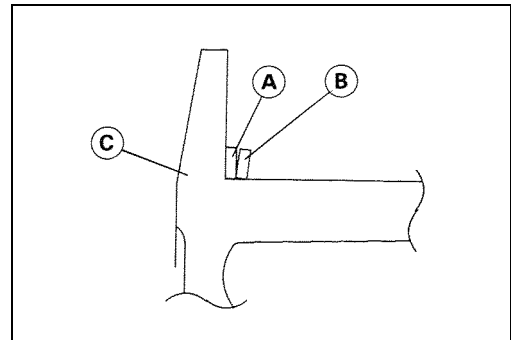

- Install the friction plates and steel plates, starting with a friction plate and alternating them.

CAUTION

If new dry friction plates and steel plates are installed, apply engine oil to the surfaces of each plate to avoid clutch plate seizure.

- Install the last friction plate [A] fitting the tangs in the grooves in the housing as shown.

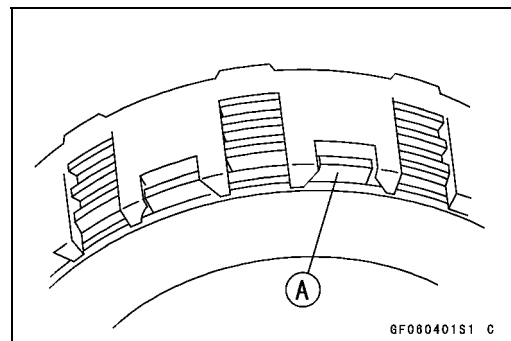

Clutch

- Apply molybdenum disulfide grease to the pusher end [A] and install the bearing [B], pusher [C] spring [D] and washer [E] in the clutch spring plate [F].

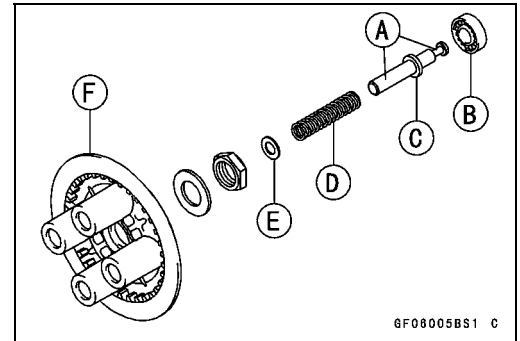

- Install the clutch spring plate and spring, and tighten the clutch spring bolts.

Torque - Clutch Spring Bolts: 8.8 N·m (0.90 kgf·m, 78 in·lb)

- Install the clutch cover (see Clutch Cover Installation).

Clutch Plate Assembly Inspection

- Inspect the friction plate thickness (see Clutch Plate, Wear, Damage Inspection).
- Measure the length [A] of the clutch plate assembly as shown.

○Assemble:

- Clutch Hub [B]
- Spring Seat [C]
- Spring [D]
- Friction Plate [E]
- Steel Plate [F]
- Spring Plate [G]
- Springs [H]
- Spring Holders [I]
- Spring Bolts [J]

○Tighten:

Torque - Clutch Spring Bolts: 8.8 N·m (0.90 kgf·m, 78 in·lb)

Clutch Plate Assembly

Standard: 37.7 ~ 38.3 mm (1.48 ~ 1.51 in.)

- ★ If the length is not within the specified range, adjust the length (see Clutch Plate Assembly Adjustment).

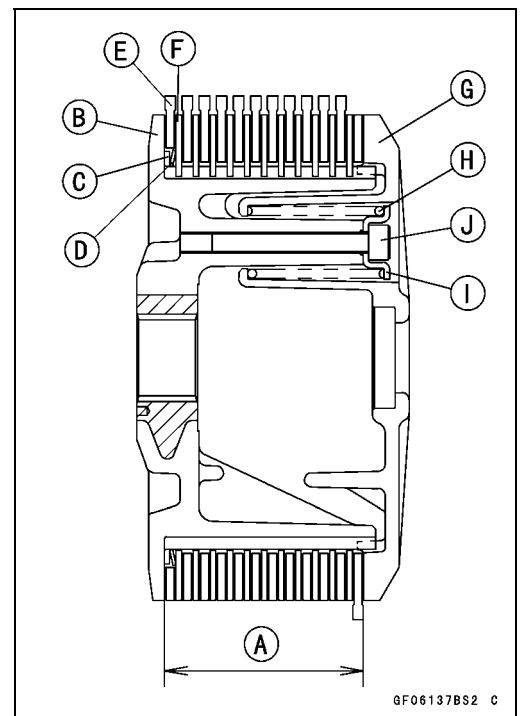

5-10 CLUTCH

Clutch

Clutch Plate Assembly Adjustment

- Inspect the clutch plate assembly length, and then replace the steel plate(s) which brings the length within the specified range.
- Remove:
 - Spring Bolts
 - Spring Holders
 - Springs
 - Spring Plate
- Replace the following steel plate(s).

Part No.	Thickness
13089-1126	1.4 mm (0.055 in.)
13089-013	1.6 mm (0.063 in.) (STD)
13089-1073	2.0 mm (0.08 in.)

NOTE

○ Do not use the steel plate of 1.4 mm and 2.0 mm thickness at the same time.

- Install the removed parts, and inspect the clutch plate assembly length.
- Tighten:
 - Torque - Clutch Spring Bolts: 8.8 N·m (0.90 kgf·m, 78 in·lb)**

Clutch Plate Wear, Damage Inspection

- Visually inspect the friction and steel plates for signs of seizure, overheating (discoloration), or uneven wear.
- Measure the thickness of each friction plate [A] at several points.
- ★ If any plates show signs of damage, or if they have worn past the service limit, replace them with new ones.

Friction Plate Thickness

Standard: 2.72 ~ 2.88 mm (0.107 ~ 0.113 in.)

Service Limit: 2.2 mm (0.087 in.)

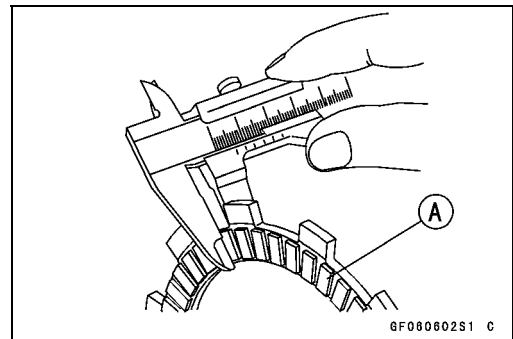

Clutch Plate Warp Inspection

- Place each friction plate or steel plate on a surface plate and measure the gap between the surface plate [A] and each friction plate or steel plate [B] with a thickness gauge [C]. The gap is the amount of friction or steel plate warp.
- ★ If any plate is warped over the service limit, replace it with a new one.

Friction and Steel Plate Warp

Standard: 0.2 mm (0.008 in.) or less

Service Limit: 0.3 mm (0.012 in.)

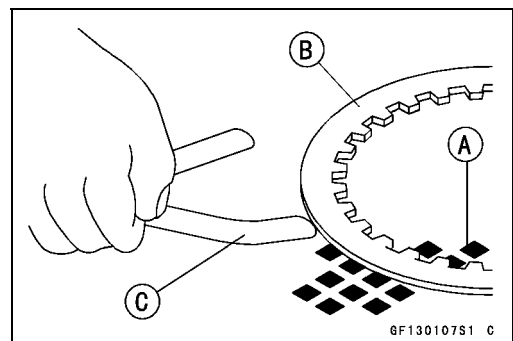

Clutch

Clutch Spring Free Length Measurement

- Measure the free length of the clutch springs [A].
- ★ If any spring is shorter than the service limit, it must be replaced.

Clutch Spring Free Length

Standard: 82.1 mm (3.23 in.)

Service Limit: 78.0 mm (3.07 in.)

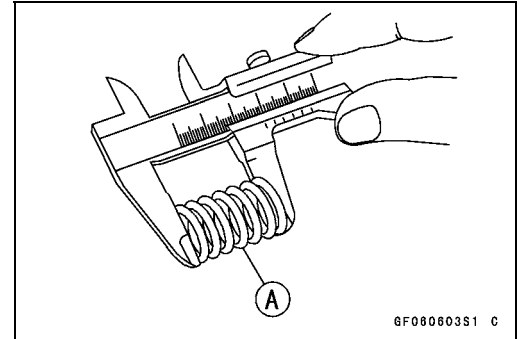

6F080603S1 C

Engine Lubrication System

Table of Contents

Exploded View	6-2
Engine Oil Flow Chart.....	6-3
Specifications	6-4
Engine Oil and Oil Filter.....	6-5
Oil Level Inspection.....	6-5
Engine Oil Change.....	6-5
Oil Filter Change	6-6
Oil Pan.....	6-7
Oil Pan Removal	6-7
Oil Pan Installation	6-7
Oil Pressure Relief Valve.....	6-8
Oil Pressure Relief Valve Removal	6-8
Oil Pressure Relief Valve Installation	6-8
Oil Pressure Relief Valve Inspection.....	6-8
Oil Pump.....	6-9
Oil Pump Removal	6-9
Oil Pump Installation	6-9
Oil Pump Drive Gear Removal.....	6-10
Oil Pump Drive Gear Installation.....	6-10
Oil Cooler.....	6-11
Oil Cooler Removal	6-11
Oil Cooler Installation.....	6-11
Oil Pressure Measurement.....	6-12
Oil Pressure Measurement	6-12
Oil Pressure Switch	6-13
Oil Pressure Switch Removal	6-13
Oil Pressure Switch Installation	6-13

6-2 ENGINE LUBRICATION SYSTEM

Exploded View

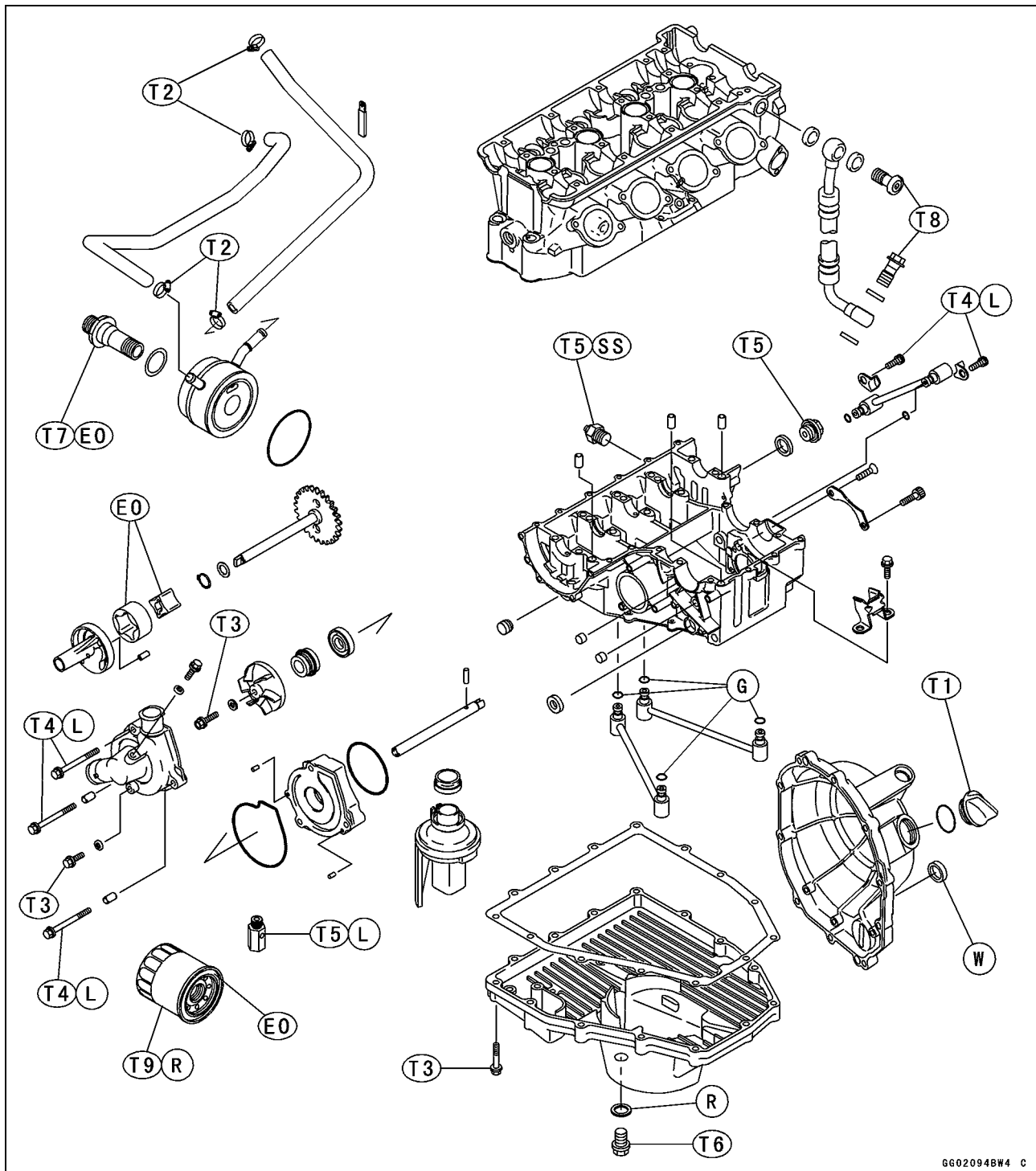

GG02094B#4 C

- T1: 1.5 N·m (0.15 kgf·m, 13 in·lb) or Hand-Tight
- T2: 2.0 N·m (0.20 kgf·m, 17 in·lb)
- T3: 9.8 N·m (1.0 kgf·m, 87 in·lb)
- T4: 12 N·m (1.2 kgf·m, 104 in·lb)
- T5: 15 N·m (1.5 kgf·m, 11 ft·lb)
- T6: 20 N·m (2.0 kgf·m, 14.5 ft·lb)
- T7: 78 N·m (8.0 kgf·m, 58 ft·lb)

- T8: 25 N·m (2.5 kgf·m, 18 ft·lb)
- T9: 31 N·m (3.2 kgf·m, 23 ft·lb)
- EO: Apply engine oil.
- G: Apply grease.
- L: Apply a non-permanent locking agent
- R: Replacement Parts
- SS: Apply silicone sealant.
- W: Apply water.

Engine Oil Flow Chart

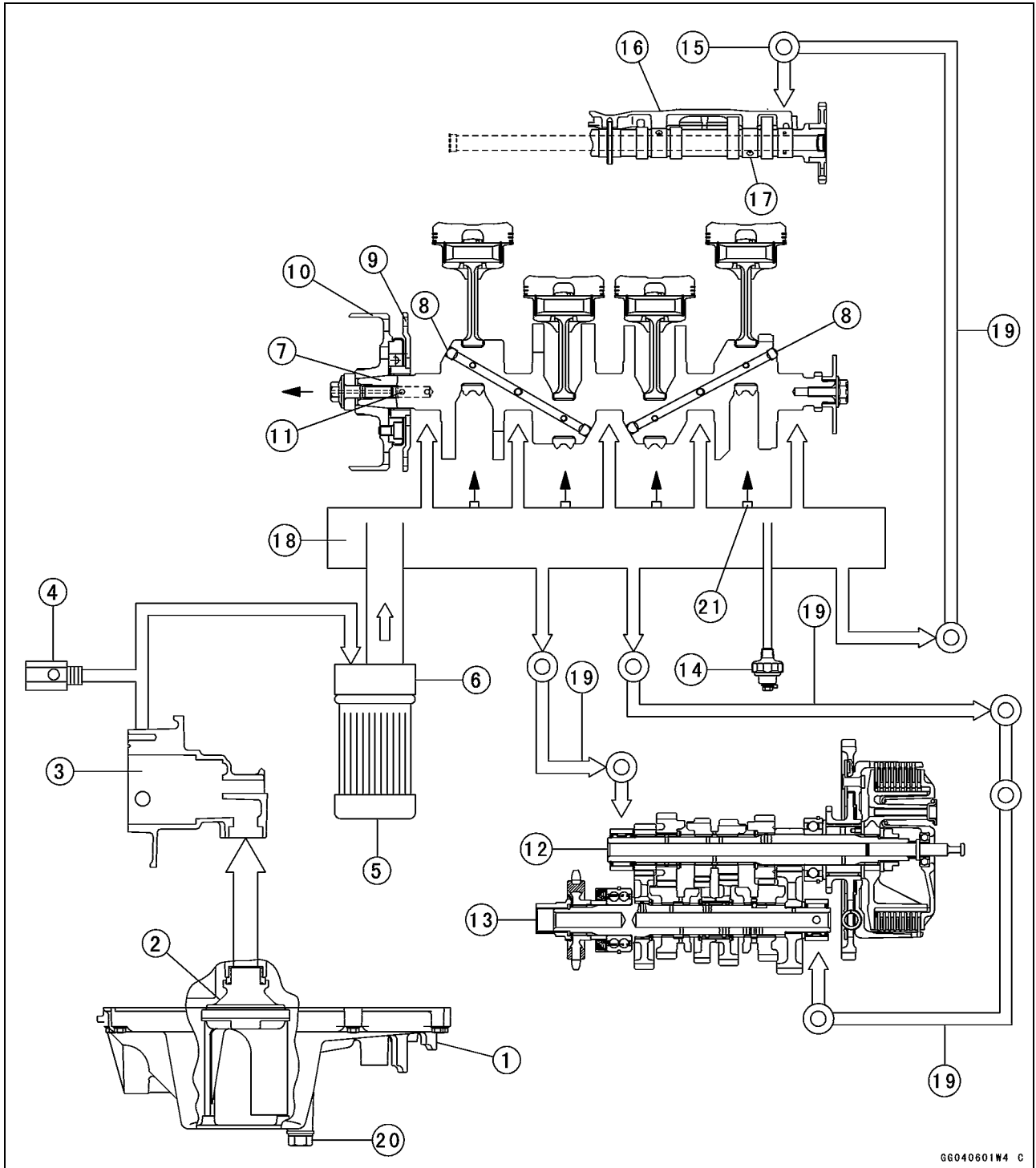

GG040601W4 C

- | | |
|-------------------------------------|-------------------------|
| 1. Oil Pan | 12. Drive Shaft |
| 2. Oil Screen | 13. Output Shaft |
| 3. Oil Pump | 14. Oil Pressure Switch |
| 4. Oil Pressure Relief Valve | 15. Cylinder Head |
| 5. Oil Filter | 16. Camshaft Cap |
| 6. Oil Cooler | 17. Camshaft |
| 7. Crankshaft | 18. Oil Passage |
| 8. To Connecting Rod Journals | 19. Oil Pipe |
| 9. Starter Clutch Gear | 20. Oil Drain Plug |
| 10. Alternator Rotor | 21. Oil Nozzles |
| 11. Starter Clutch Oil Passage Hole | |

6-4 ENGINE LUBRICATION SYSTEM

Specifications

Item	Standard	
Engine Oil Grade Viscosity Capacity Level	ZX600-J1 ~ J2	ZX600-J3 ~
	API SE, SF or SG	←
	API SH, SJ or SL with JASO MA	←
	SAE 10W-40, 10W-50, 20W-40, or 20W-50	SAE10W-40
	3.4 L (3.6 US qt) (when filter is not removed)	←
	3.6 L (3.8 US qt) (when filter is removed)	←
Oil Pressure Measurement Oil pressure @4 000 r/min (rpm), oil temperature 90°C (194°F)	4.0 L (4.2 US qt) (when engine is completely dry)	←
	Between upper and lower level lines	←
	120 ~ 180 kPa (1.2 ~ 1.8 kgf/cm ² , 17 ~ 26 psi)	

Special Tools - Outside Circlip Pliers: 57001-144

Oil Pressure Gauge, 10 kgf/cm²: 57001-164

Oil Filter Wrench: 57001-1249

Oil Pressure Gauge Adapter, M18 × 1.5: 57001-1278

Sealant - Kawasaki Bond (Silicone Sealant): 56019-120

Engine Oil and Oil Filter

⚠ WARNING

Motorcycle operation with insufficient, deteriorated, or contaminated engine oil will cause accelerated wear and may result in engine or transmission seizure, accident, and injury.

Oil Level Inspection

- Check that the engine oil level is between the upper [A] and lower [B] levels in the gauge.

NOTE

- Situate the motorcycle so that it is perpendicular to the ground.
- If the motorcycle has just been used, wait several minutes for all the oil to drain down.
- If the oil has just been changed, start the engine and run it for several minutes at idle speed. This fills the oil filter with oil. Stop the engine, then wait several minutes until the oil settles.

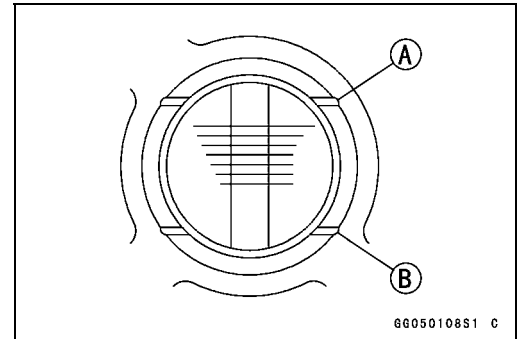

CAUTION

Racing the engine before the oil reaches every part can cause engine seizure. If the engine oil gets extremely low or if the oil pump or oil passages clog up or otherwise do not function properly, the oil pressure warning light will light. If this light stays on when the engine is running above idle speed, stop the engine immediately and find the cause.

Engine Oil Change

- Situate the motorcycle so that it is vertical after warming up the engine.
- Remove the engine drain plug [A] to drain the oil.
- The oil in the oil filter can be drained by removing the filter (see Oil Filter Change).
- ★ Replace the drain plug gasket [B] with a new one if it is damaged.
- Tighten the drain plug.
 - Torque - Engine Drain Plug: 20 N·m (2.0 kgf·m, 14.5 ft·lb)
- Pour in the specified type and amount of oil.

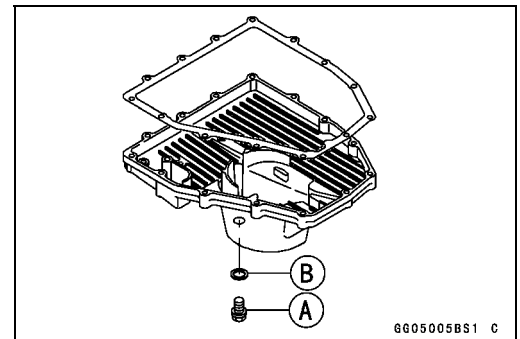

Engine Oil

	ZX600-J1 ~ J2	ZX600-J3 ~
Grade:	API SE, SF or SG API SH, SJ or SL with JASO MA	←
Viscosity:	SAE 10W40, 10W50, 20W40, or 20W50	SAE 10W40
Amount:	3.4 L (3.6 US qt) (when filter is not removed)	←
	3.6 L (3.8 US qt) (when filter is removed)	←
	4.0 L (4.2 US qt) (when engine is completely dry)	←

6-6 ENGINE LUBRICATION SYSTEM

Engine Oil and Oil Filter

NOTE

○Although 10W-40 engine oil is the recommended oil for most conditions, the oil viscosity may need to be changed to accommodate atmospheric conditions in your riding area.

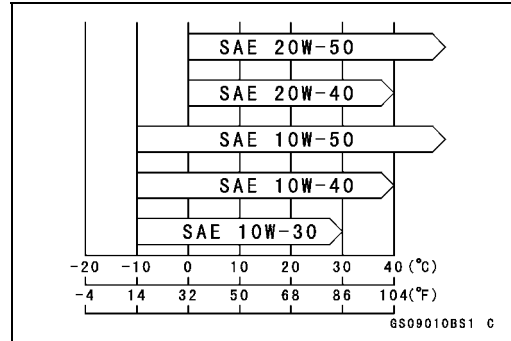

Oil Filter Change

- Drain the engine oil (see Engine Oil Change).
- Remove:
 - Left Lower Fairing (see Frame chapter)
- Remove the oil filter [A] with the oil filter wrench [B].

Special Tool - Oil Filter Wrench: 57001-1249



- Replace the filter with a new one.
- Apply engine oil to the gasket [A] before installation.
- Tighten the filter with the oil filter wrench.

Torque - Oil Filter: 31 N·m (3.2 kgf·m, 23 ft·lb)

NOTE

○Hand tightening of the oil filter can not be allowed since it does not reach to this tightening torque.

- Pour in the specified type and amount of oil (see Engine Oil Change).

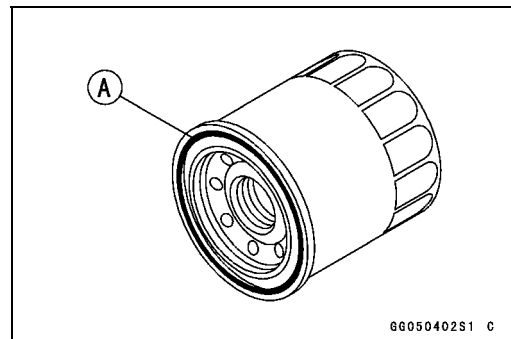

GG050402S1 C

Oil Pan

Oil Pan Removal

- Remove:
 - Engine Oil (drain, see Engine Oil Change)
 - Muffler (see Engine Top End chapter)
 - Oil Pan Bolts [A]
 - Oil Pan [B]

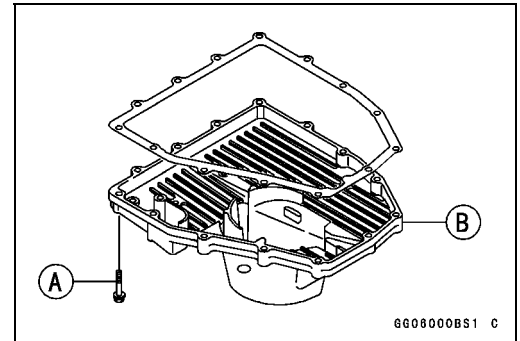

Oil Pan Installation

- Clean the oil screen [A].
- Install the oil screen so that the crankcase rib [B] fits the slot [C] of the oil screen.

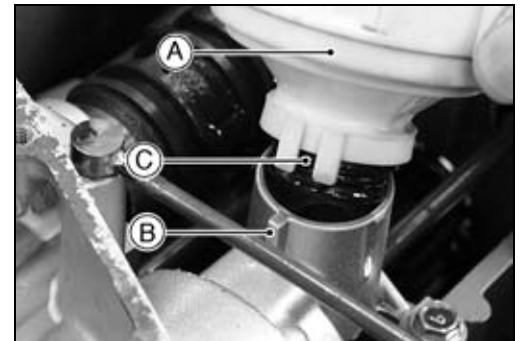

- Apply grease to the O-rings on the oil pipes [A].
- ★ If the relief valve was removed, install it.
- Apply a non-permanent locking agent to the threads of the relief valve [B], and tighten it.

Torque - Oil Pressure Relief Valve: 15 N·m (1.5 kgf·m, 11 ft·lb)

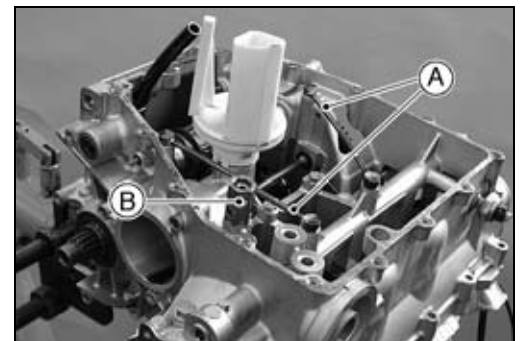

CAUTION

Do not apply too much non-permanent locking agent to the threads. This may block the oil passage.

- Replace the oil pan gasket with a new one.
- Tighten:
 - Torque - Oil Pan Bolts: 9.8 N·m (1.0 kgf·m, 87 in·lb)**

6-8 ENGINE LUBRICATION SYSTEM

Oil Pressure Relief Valve

Oil Pressure Relief Valve Removal

- See the Oil Pan Removal.

Oil Pressure Relief Valve Installation

- See the Oil Pan Installation.

Oil Pressure Relief Valve Inspection

- Check to see if the valve [A] slides smoothly when pushing it in with a wooden or other soft rod, and see if it comes back to its seat by spring [B] pressure.

NOTE

○ *Inspect the valve in its assembled state. Disassembly and assembly may change the valve performance.*

- ★ If any rough spots are found during above inspection, wash the valve clean with a high-flash point solvent and blow out any foreign particles that may be in the valve with compressed air.

⚠ WARNING

Clean the relief valve in a well-ventilated area, and take care that there is no spark or flame anywhere near the working area. Because of the danger of highly flammable liquids, do not use gasoline or low-flash point solvent.

- ★ If cleaning does not solve the problem, replace the relief valve as an assembly. The relief valve is precision made with no allowance for replacement of individual parts.

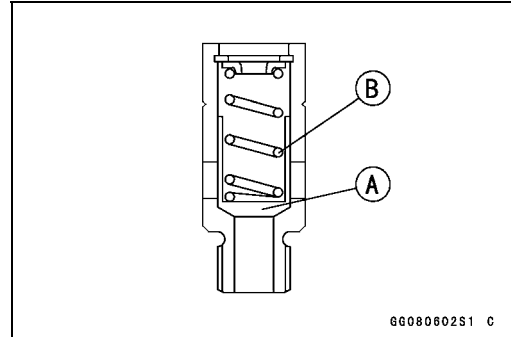

Oil Pump

Oil Pump Removal

- Drain:
 - Coolant (see Cooling System chapter)
 - Engine Oil (see Engine Oil Change)
- Remove:
 - Water Hoses [A]
 - Bolts [B] and Water Pump Cover [C]

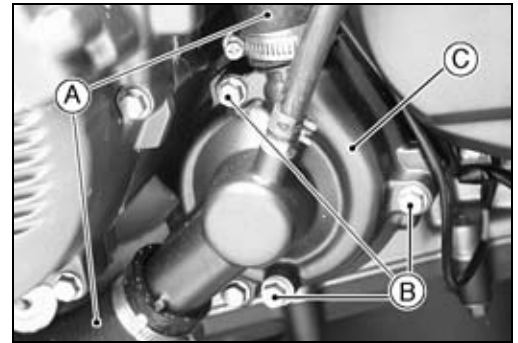

Impeller Bolt [A]
Impeller [B]

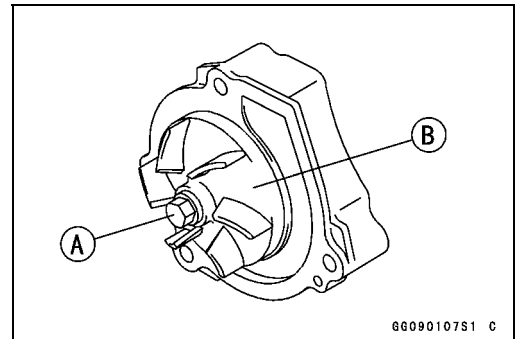

6G090107S1 C

Water Pump Body [A]
Oil Pump Cover [B]
Oil (Water) Pump Shaft [C]
Outer Rotor [D] and Inner Rotor

NOTE

- The oil (water) pump assembly can easily be removed by installing water pump cover bolt [E] into the oil (water) pump shaft and pulling them.

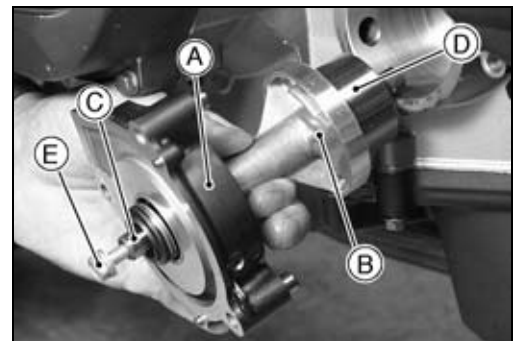

Oil Pump Installation

- Install the outer rotor [A] in to the crankcase.
- Install the pin [B], inner rotor [C] and oil (water) pump shaft [D].
- Turn the pump shaft so that the slot [E] in its shaft fits onto the projection [F] of the pump drive gear shaft.

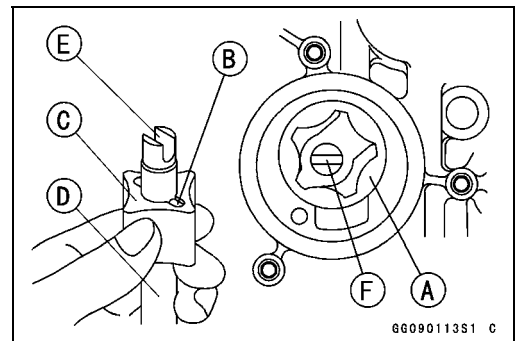

6G090113S1 C

- Fit the pin [A] of the oil pump cover [B] into the hole [C] in the crankcase.

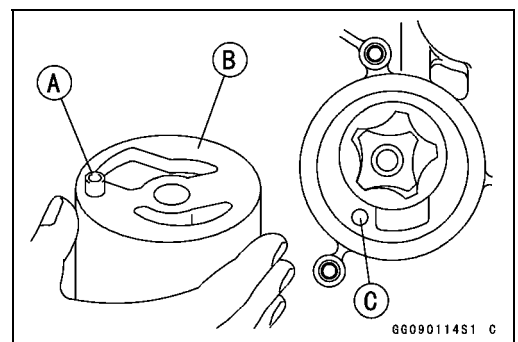

6G090114S1 C

6-10 ENGINE LUBRICATION SYSTEM

Oil Pump

- Install:
 - Pins [A]
 - Water Pump Body [B]

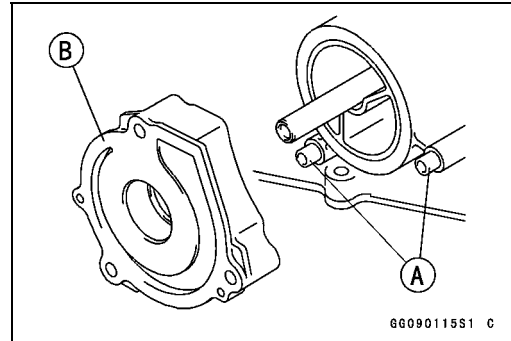

- Tighten:
 - Impeller [A] and Bolt [B]
- Torque - Impeller Bolt: 9.8 N·m (1.0 kgf·m, 87 in·lb)
- Install:
 - Pins [C]
 - Water Pump Cover [D]
- Apply a non-permanent locking agent to the threads of the water pump cover bolts, and tighten them.
- Torque - Water Pump Cover Bolts: 12 N·m (1.2 kgf·m, 104 in·lb)

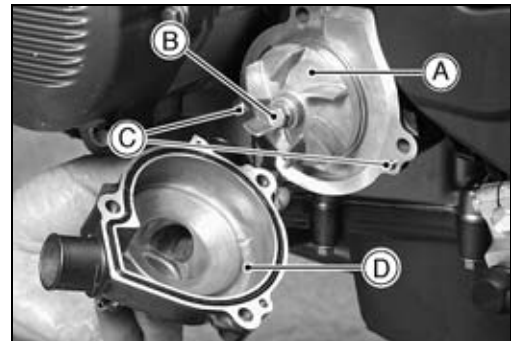

Oil Pump Drive Gear Removal

- Remove:
 - Clutch (see Clutch chapter)
 - Oil Pan (see Oil Pan Removal)
 - Circlip [A] and Washer [B]
- Special Tool - Outside Circlip Pliers: 57001-144
- Oil Pump Drive Gear [C]

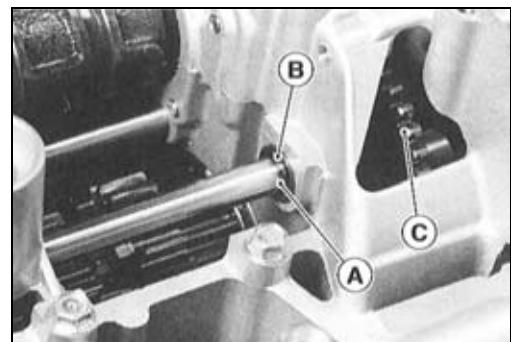

Oil Pump Drive Gear Installation

- Install the circlip [A] into the groove [B] of the oil pump drive gear shaft.
- Special Tool - Outside Circlip Pliers: 57001-144

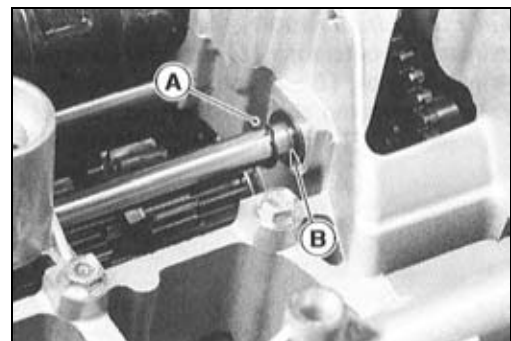

Oil Cooler

Oil Cooler Removal

- Remove:
 - Lower Fairing (see Frame chapter)
- Drain:
 - Engine Oil (see Engine Oil Change)
 - Coolant (see Cooling System chapter)
- Remove the oil filter.
- Remove the oil cooler hoses [A] from the oil cooler.
- Unscrew the oil cooler bolt [B] from the crankcase, and remove the oil cooler [C].

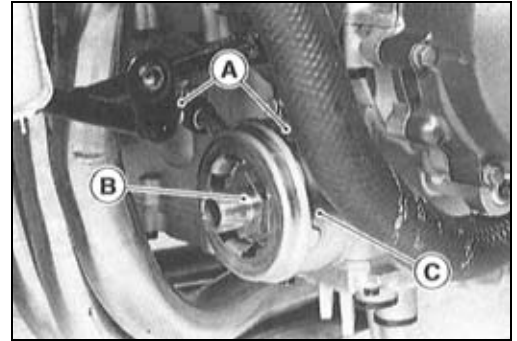

Oil Cooler Installation

- Apply grease to the O-ring [A] before installation.
- Apply engine oil to the oil cooler bolt, and install the oil cooler with the bolt.

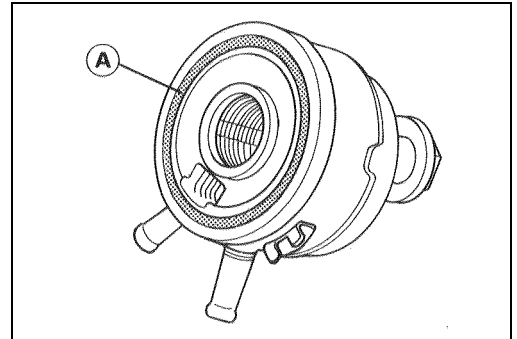

- Install the oil cooler so that the crankcase rib [A] fits the slot [B] of the oil cooler.
- Tighten:
 - Torque - Oil Cooler Mounting Bolt: 78 N·m (8.0 kgf·m, 58 ft·lb)**
- Pour:
 - Engine Oil (see Engine Oil Change)
 - Coolant (see Cooling System chapter)

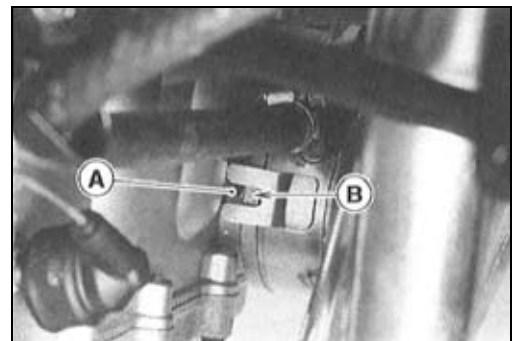

6-12 ENGINE LUBRICATION SYSTEM

Oil Pressure Measurement

Oil Pressure Measurement

- Remove the lower fairing (see Frame chapter).
- Remove the oil passage plug, and attach the gauge [A] and adapter [B] to the plug hole.

Special Tools - Oil Pressure Gauge, 10 kgf/cm²: 57001-164
Oil Pressure Gauge Adapter, M18 × 1.5:
57001-1278

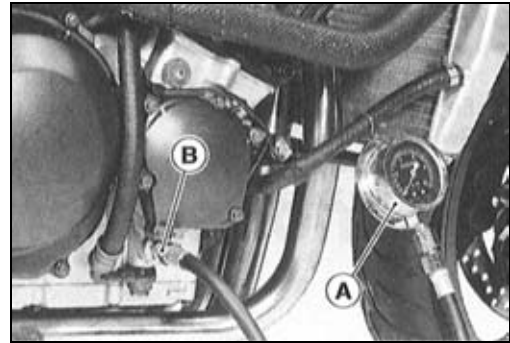

- Start the engine and warm up the engine.
- Run the engine at the specified speed, and read the oil pressure gauge.
- ★ If the oil pressure is much lower than the standard, check the oil pump, oil pump relief valve, and/or crankshaft bearing insert wear immediately.
- ★ If the reading is much higher than the standard, check the oil passaged for clogging.

Oil Pressure

Standard: 120 ~ 180 kPa (1.2 ~ 1.8 kgf/cm², 17 ~ 26 psi)
@4 000 r/min (rpm), oil temp. 90°C (194 °F)

- Stop the engine.
- Remove the oil pressure gauge and adapter.

⚠ WARNING

Take care against burns form hot engine oil that will drain through the oil passage when the gauge adapter is removed.

- Install the oil passage plug and tighten it.
Torque - Oil Passage Plug (Right): 15 N·m (1.5 kgf·m, 11 ft·lb)

Oil Pressure Switch

Oil Pressure Switch Removal

- Remove:
 - Right Lower Fairing (see Frame chapter)
 - Engine Oil (drain, see Engine Oil Change)
 - Switch Cover [A]
 - Switch Terminal [B]
 - Oil Pressure Switch [C]

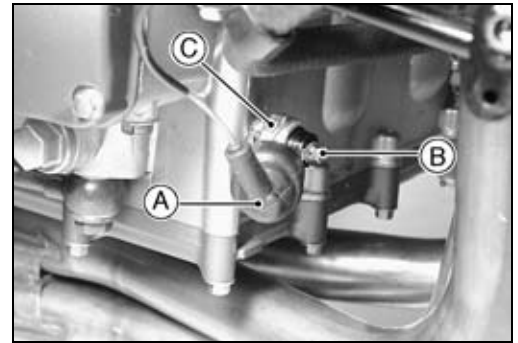

Oil Pressure Switch Installation

- Apply silicone sealant to the threads of the oil pressure switch and tighten it.
 - Sealant - Kawasaki Bond (Silicone Sealant): 56019-120**
 - Torque - Oil Pressure Switch: 15 N·m (1.5 kgf·m, 11 ft·lb)**
- Tighten:
 - Torque - Oil Pressure Switch Terminal Bolt: 1.5 N·m (0.15 kgf·m, 13 in·lb)**
- Apply grease to the terminal.

Engine Removal/Installation

Table of Contents

Exploded View	7-2
Specifications	7-3
Engine Removal/Installation	7-4
Engine Removal.....	7-4
Engine Installation.....	7-5

7-2 ENGINE REMOVAL/INSTALLATION

Exploded View

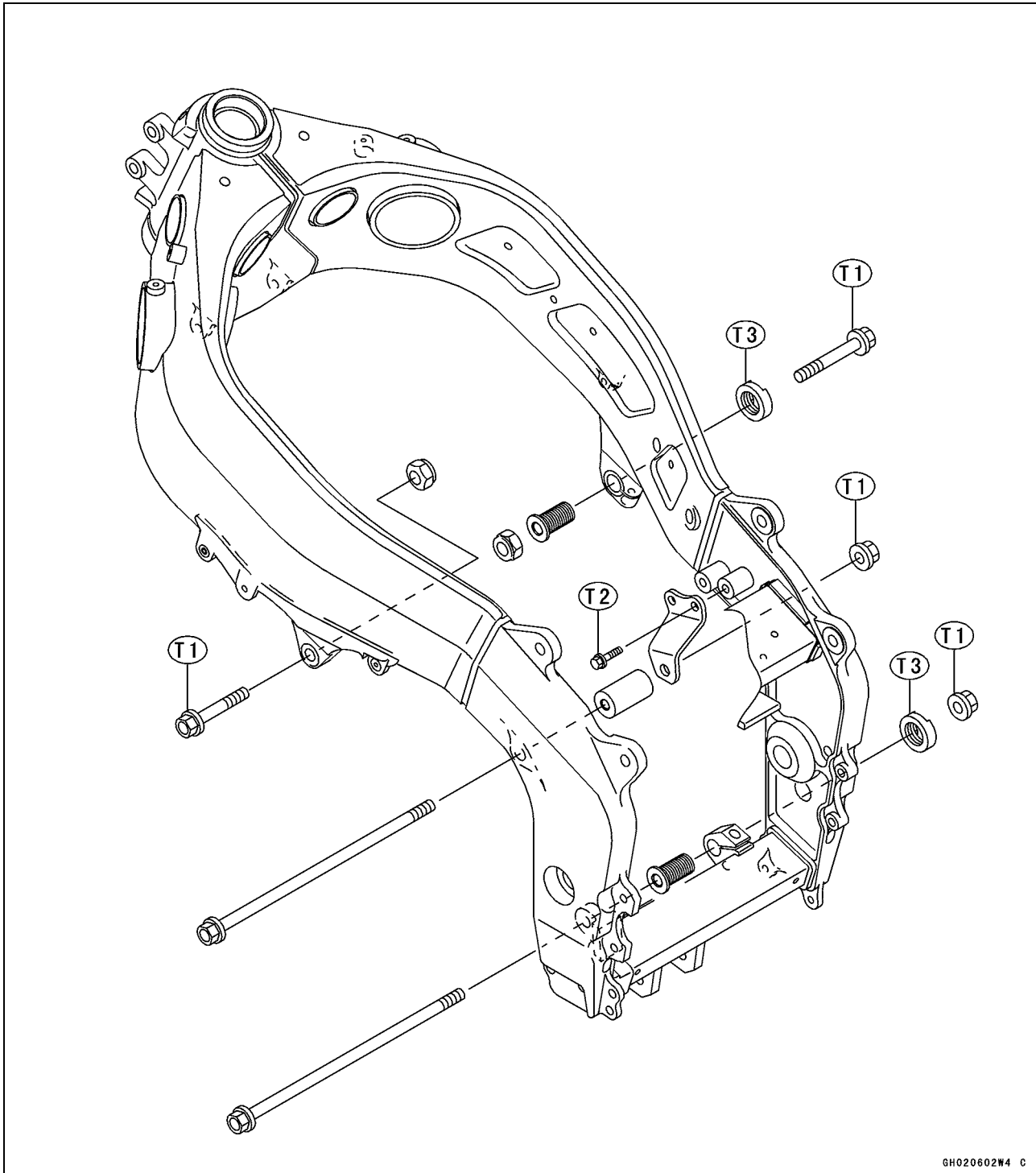

T1: 44 N·m (4.5 kgf·m, 33 ft·lb)

T2: 25 N·m (2.5 kgf·m, 18 ft·lb)

T3: 49 N·m (5.0 kgf·m, 36 ft·lb)

Specifications

Special Tool - Jack: 57001-1238

Engine Mount Nut Wrench: 57001-1450

7-4 ENGINE REMOVAL/INSTALLATION

Engine Removal/Installation

Engine Removal

- Squeeze the brake lever slowly and hold it with a band [A].

⚠ WARNING

Be sure to hold the front brake when removing the engine, or the motorcycle may fall over. It could cause an accident and injury.

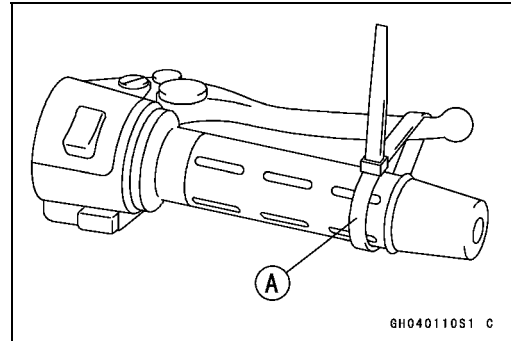

CAUTION

Be sure to hold the front brake when removing the engine, or the motorcycle may fall over. The engine or the motorcycle could be damaged.

- Drain:
 - Engine Oil (see Engine Lubrication System chapter)
 - Coolant (see Cooling System chapter)
 - Remove:
 - Lower Fairings (see Frame chapter)
 - Fuel Tank (see Fuel System chapter)
 - Air Cleaner Housing (see Fuel System chapter)
 - Carburetors (see Fuel System chapter)
 - Baffle Plate on the Cylinder Head Cover
- Radiator [A]
Clutch Cable Lower End [B]
Muffler [C]

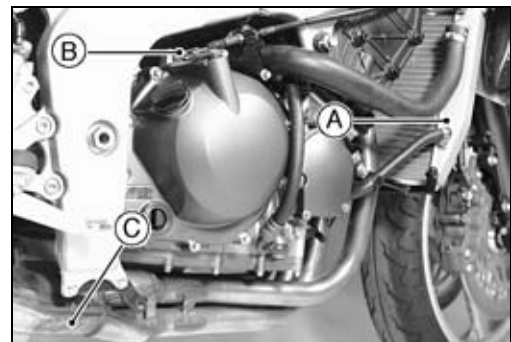

- Shift Lever [A]
Reserve Tank [B]
Speed Sensor [C]
Engine Sprocket (see Final Drive chapter)

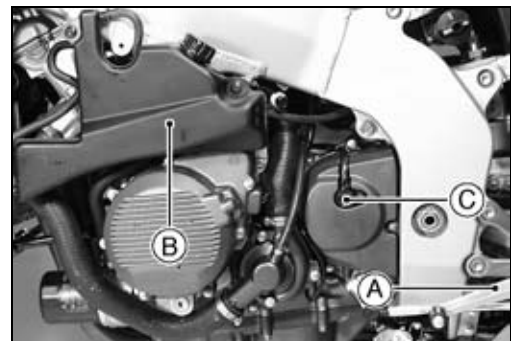

Engine Removal/Installation

- Pull off the connectors from the engine and free the wiring from the clamps.
 - Crankshaft Sensor Lead Connector [A]
 - Battery Ground Cable [B]
 - Starter Motor Cable [C]
 - Alternator Lead Connector [D]
 - Side Stand Switch Lead Connector [E]
 - Speed Sensor Connector [F]

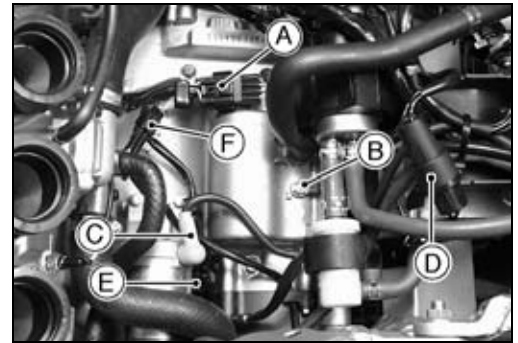

- Stick Coil Harness Connector [A]
- Support the rear part of the frame on the jack.
 - **Special Tool - Jack: 57001-1238**



- Support the engine with a suitable stand [A].
- Remove the engine mounting bolts and nuts [B].
- Loosen the locknuts and adjusting bolts [C].
 - **Special Tool - Engine Mount Nut Wrench: 57001-1450**
- Remove the drive chain from the output shaft.
- Using the stand, take out the engine.

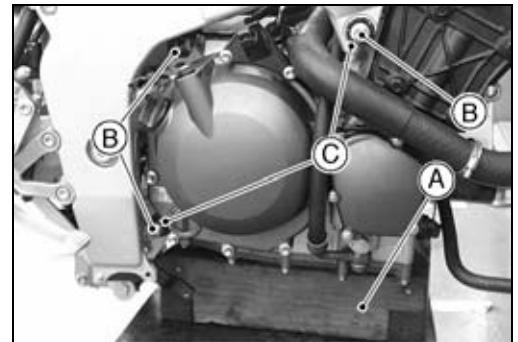

Engine Installation

- Before engine installation loosen the engine bracket bolts [A].
- Support the engine with a suitable stand.
- Hang the drive chain over the output shaft just before moving the engine into its final position in the frame.
- Screw the adjusting bolts [H], [J] into the frame.
- Insert the lower mounting bolt [B].
- Insert the upper mounting bolts [C], [G].
- Set the collar [D] and insert the middle mounting bolts [E].

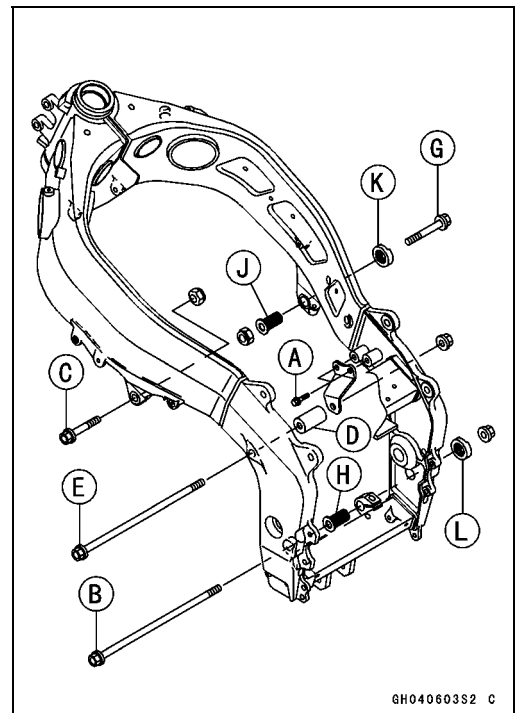

7-6 ENGINE REMOVAL/INSTALLATION

Engine Removal/Installation

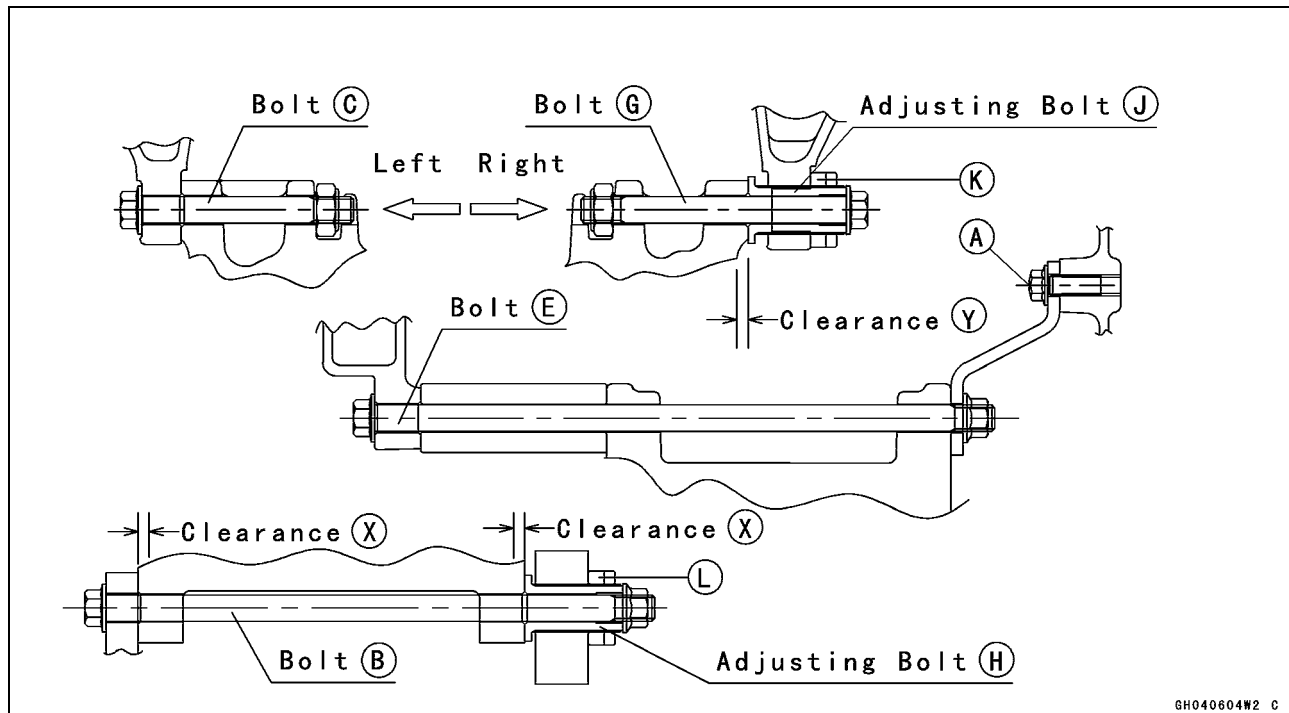

- Turn the adjusting bolt [H] until the clearance [X] between the crankcase and frame come to zero mm.
- Tighten the bracket bolts [A].

Torque - Engine Bracket Bolts: 25 N·m (2.5 kgf·m, 18 ft·lb)

- Tighten the engine mounting bolts [C], [B], [E] and locknut [L] with specified torque.

Torque - Engine Mounting Bolts: 44 N·m (4.5 kgf·m, 33 ft·lb)
Engine Mounting Locknuts: 49 N·m (5.0 kgf·m, 36 ft·lb)

Special Tool - Engine Mount Nut Wrench: 57001-1450

- Pull out the engine mounting bolt [G] temporarily, and turn the adjusting bolt [J] until the clearance [Y] between the adjusting bolt and cylinder come to zero mm.
- Insert the bolt [G] into engine mounting hole, and tighten the bolt and locknut [K] with specified torque

Torque - Engine Mounting Bolts: 44 N·m (4.5 kgf·m, 33 ft·lb)
Engine Mounting Locknuts: 49 N·m (5.0 kgf·m, 36 ft·lb)

Special Tool - Engine Mount Nut Wrench: 57001-1450

- Run the leads, cables and hoses correctly (see Cable, Wire and Hose Routing section in the General Information chapter).
- Install the removed parts (see appropriate chapters).
- Adjust:
 - Throttle Cables (see Fuel System chapter)
 - Choke Cable (see Fuel System chapter)
 - Clutch Cable (see Clutch chapter)
 - Drive Chain (see Final drive chapter)
- Fill the engine with engine oil (see Engine Lubrication System chapter).
- Fill the engine with coolant and bleed the air from the cooling system (see Cooling System chapter).

Crankshaft/Transmission

Table of Contents

Exploded View	8-2	Starter Motor Clutch Inspection ...	8-17
Specifications	8-4	Starter Motor Clutch Disassembly	8-17
Crankcase Splitting.....	8-6	Starter Motor Clutch Assembly	8-17
Crankcase Splitting	8-6	Transmission	8-18
Crankcase Assembly	8-7	Shift Pedal Removal	8-18
Crankshaft and Connecting Rods.....	8-9	Shift Pedal Installation	8-18
Crankshaft Removal	8-9	External Shift Mechanism	
Crankshaft Installation	8-9	Removal.....	8-18
Connecting Rod Removal.....	8-9	External Shift Mechanism	
Connecting Rod Installation.....	8-9	Installation.....	8-18
Crankshaft/Connecting Rod		External Shift Mechanism	
Cleaning	8-12	Inspection.....	8-19
Connecting Rod Bend Inspection	8-12	Transmission Shaft Removal	8-19
Connecting Rod Twist Inspection.	8-13	Transmission Shaft Installation ...	8-19
Connecting Rod Big End Side		Transmission Shaft Disassembly .	8-20
Clearance Inspecton	8-13	Transmission Shaft Assembly.....	8-20
Connecting Rod Big End		Shift Drum and Fork Removal.....	8-21
Bearing Insert/Crankpin Wear		Shift Drum and Fork Installation...	8-22
Inspection.....	8-13	Shift Drum Disassembly.....	8-22
Crankshaft Side Clearance		Shift Drum Assembly	8-22
Inspection.....	8-15	Shift Fork Bending Inspection	8-22
Crankshaft Runout Inspection.....	8-15	Shift Fork/Gear Groove Wear	
Crankshaft Main Bearing		Inspection.....	8-23
Insert/Journal Wear Inspection .	8-15	Shift Fork Guide Pin/Drum	
Starter Motor Clutch	8-17	Groove Wear Inspection	8-23
Starter Motor Clutch		Gear Dog and Gear Dog Hole	
Removal/Installation.....	8-17	Damage Inspection	8-23

8-2 CRANKSHAFT/TRANSMISSION

Exploded View

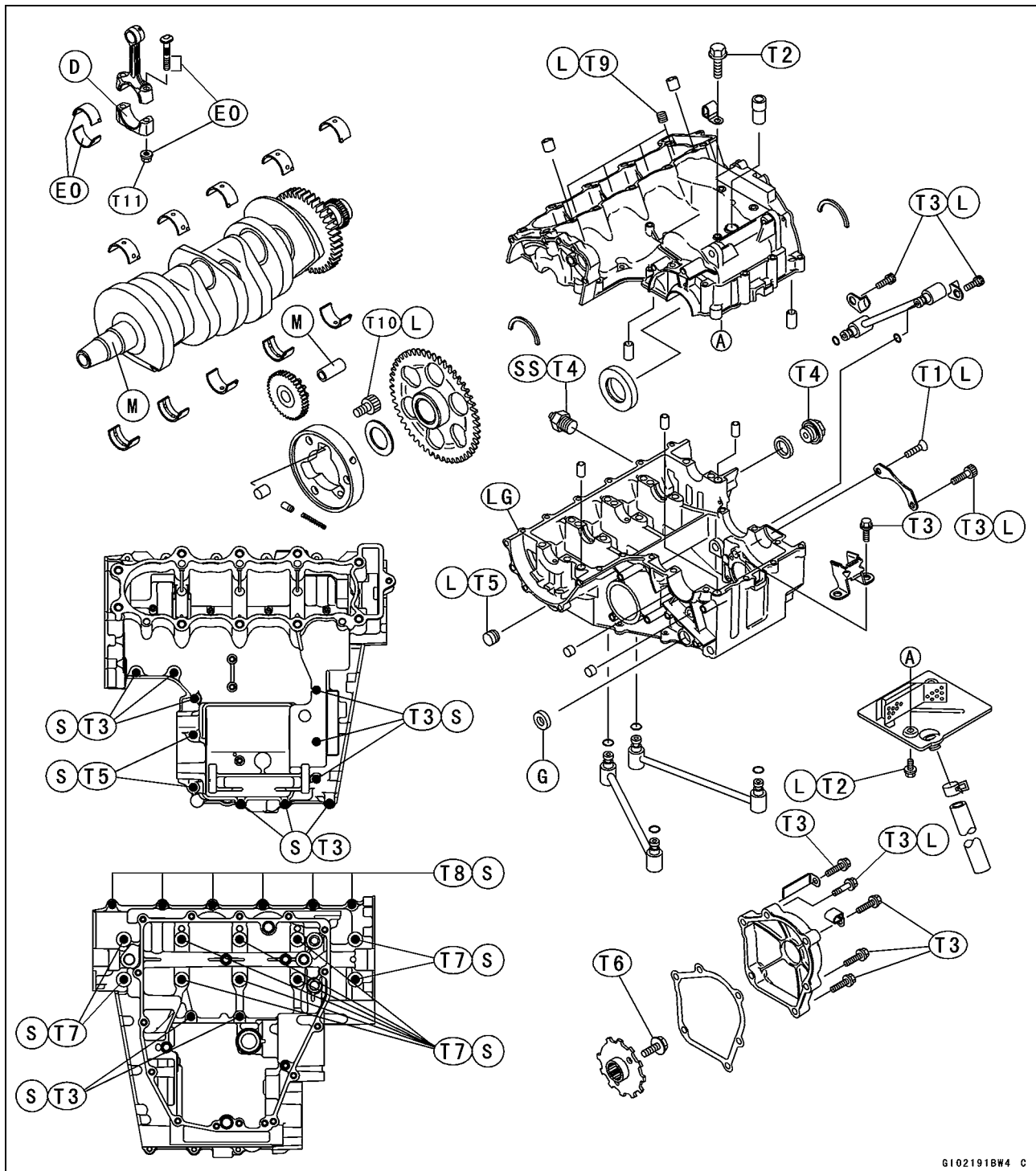

G102191B#4 C

- T1: 4.9 N·m (0.5 kgf·m, 43 in·lb)
- T2: 9.8 N·m (1.0 kgf·m, 87 in·lb)
- T3: 12 N·m (1.2 kgf·m, 104 in·lb)
- T4: 15 N·m (1.5 kgf·m, 11 ft·lb)
- T5: 20 N·m (2.0 kgf·m, 14.5 ft·lb)
- T6: 44 N·m (4.5 kgf·m, 33 ft·lb)
- T7: 30 N·m (3.0 kgf·m, 22 ft·lb)
- T8: 18 N·m (1.8 kgf·m, 13 ft·lb)
- T9: 6.9 N·m (0.70 kgf·m, 61 in·lb)
- T10: 34 N·m (3.5 kgf·m, 25 ft·lb)

- T11: See the text.
- D: Do not apply any grease or oil.
- EO: Apply engine oil.
- G: Apply grease.
- L: Apply a non-permanent locking agent.
- LG: Apply silicone sealant (92104-1063).
- M: Apply molybdenum disulfide grease.
- S: Tighten the fasteners following the specified sequence.
- SS: Apply silicone sealant (56019-120).

Exploded View

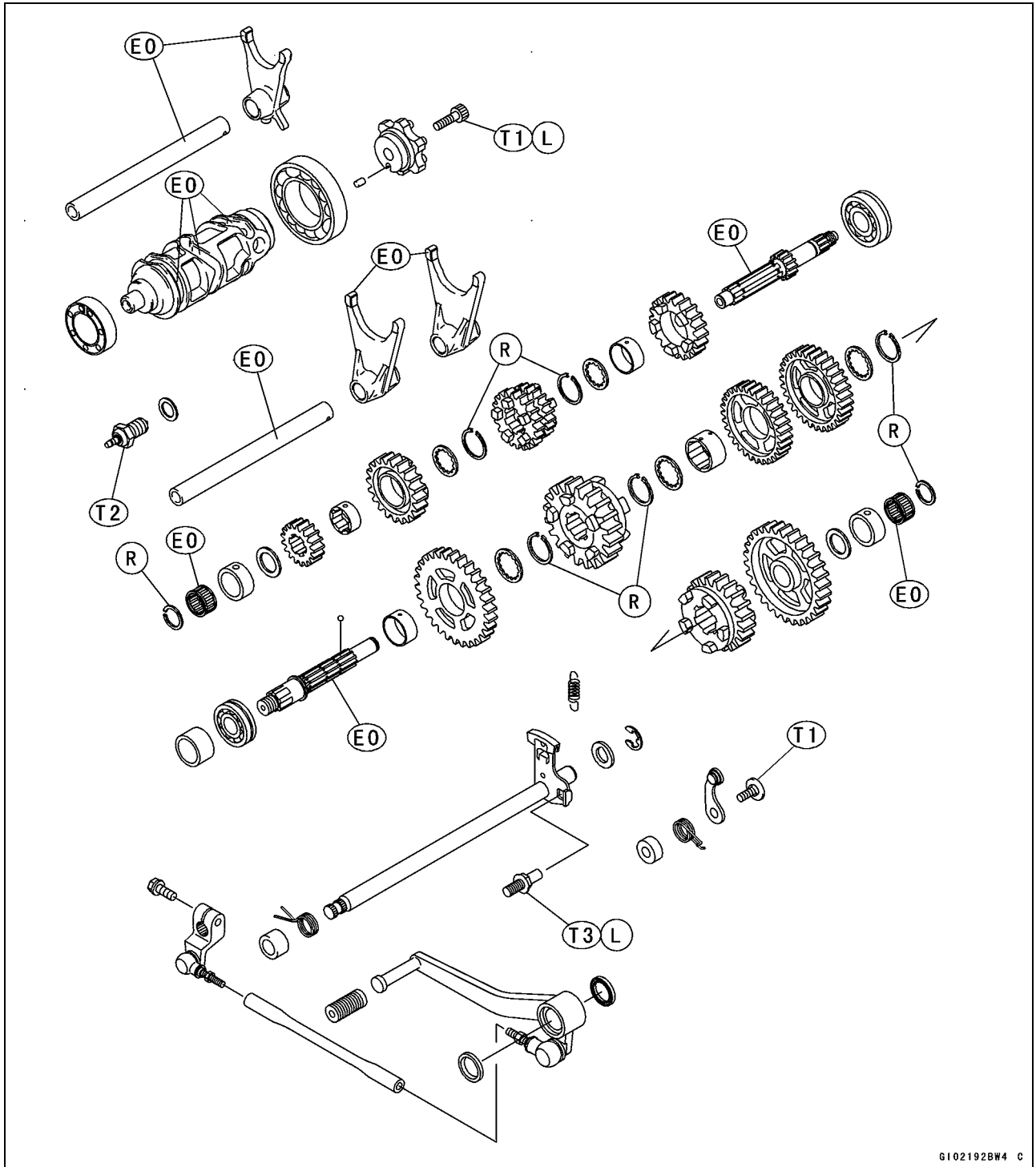

G102192BW4 C

T1: 12 N·m (1.2 kgf·m, 104 in·lb)

T2: 15 N·m (1.5 kgf·m, 11 ft·lb)

T3: 28 N·m (2.9 kgf·m, 21 ft·lb)

EO: Apply engine oil.

L: Apply a non-permanent locking agent.

R: Replacement Parts

8-4 CRANKSHAFT/TRANSMISSION

Specifications

Item	Standard	Service Limit
Crankshaft, Connecting Rods		
Connecting Rod Big End Side Clearance	0.13 ~ 0.33 mm (0.0051 ~ 0.0130 in.)	0.5 mm (0.020 in.)
Connecting Rod Big End Bearing Insert/Crankpin Clearance	0.031 ~ 0.059 mm (0.0012 ~ 0.0023 in.)	0.10 mm (0.004 in.)
Crankpin Diameter:	29.984 ~ 30.000 mm (1.1805 ~ 1.1811 in.)	29.97 mm (1.180 in.)
Marking:		
None	29.984 ~ 29.994 mm (1.1805 ~ 1.1809 in.)	---
○	29.995 ~ 30.000 mm (1.1809 ~ 1.1811 in.)	---
Connecting Rod Big End Bore Diameter:	33.000 ~ 33.016 mm (1.2992 ~ 1.2998 in.)	---
Marking:		
None	33.000 ~ 33.008 mm (1.2992 ~ 1.2995 in.)	---
○	33.009 ~ 33.016 mm (1.2996 ~ 1.2998 in.)	---
Connecting Rod Big End Bearing Insert Thickness:		
Pink	1.475 ~ 1.480 mm (0.0581 ~ 0.0583 in.)	---
Brown	1.480 ~ 1.485 mm (0.0583 ~ 0.0585 in.)	---
Black	1.485 ~ 1.490 mm (0.0585 ~ 0.0587 in.)	---

Connecting rod big end bearing insert selection:

Con-rod Big End Bore Diameter Marking	Crankpin Diameter Marking	Bearing Insert	
		Size Color	Part Number
None	○	Pink	92028-1880
None	None	Brown	92028-1879
○	○		
○	None	Black	92028-1878

Crankshaft Side Clearance	0.05 ~ 0.20 mm (0.002 ~ 0.008 in.)	0.40 mm (0.016 in.)
Crankshaft Runout	TIR 0.02 (0.0008 in.) mm or less	TIR 0.05 mm (0.002 in.)
Crankshaft Main Bearing Insert/journal Clearance	0.014 ~ 0.038 mm (0.0006 ~ 0.0015 in.)	0.07 mm (0.0028 in.)
Crankshaft Main Journal Diameter:	29.984 ~ 30.000 mm (1.1805 ~ 1.1811 in.)	29.96 mm (1.1795 in.)

Specifications

Item	Standard	Service Limit
Marking:		
None	29.984 ~ 29.994 mm (1.1805 ~ 1.1809 in.)	- - -
1	29.995 ~ 30.000 mm (1.1809 ~ 1.1811 in.)	- - -
Crankcase Main Bearing Bore Diameter:	33.000 ~ 33.016 mm (1.2992 ~ 1.2998 in.)	- - -
Marking:		
○	33.000 ~ 33.008 mm (1.2992 ~ 1.2995 in.)	- - -
None	33.009 ~ 33.016 mm (1.2996 ~ 1.2998 in.)	- - -
Crankshaft Main Bearing Insert Thickness:		
Brown	1.491 ~ 1.495 mm (0.0587 ~ 0.0589 in.)	- - -
Black	1.495 ~ 1.499 mm (0.0589 ~ 0.0590 in.)	- - -
Blue	1.499 ~ 1.503 mm (0.0590 ~ 0.0592 in.)	- - -

Crankshaft main bearing insert selection:

Crankcase Main Bearing Bore Diameter Marking	Crankshaft Main Journal Diameter Marking	Bearing Insert*		
		Size Color	Part Number	Journal Nos.
○	1	Brown	92028-1883	3, 5
			92028-1886	1, 2, 4
None	1	Black	92028-1882	3, 5
○	None		92028-1885	1, 2, 4
None	None	Blue	92028-1881	3, 5
			92028-1884	1, 2, 4

*The bearing inserts for Nos. 1, 2 and 4 journals have an oil groove, respectively.

Item	Standard	Service Limit
Transmission		
Shift Fork Ear Thickness	5.9 ~ 6.0 mm (0.2323 ~ 0.2362 in.)	5.8 mm (0.228 in.)
Gear Groove Width	6.05 ~ 6.15 mm (0.2382 ~ 0.2421 in.)	6.25 mm (0.246 in.)
Shift Fork Guide Pin Diameter	5.9 ~ 6.0 mm (0.2323 ~ 0.2362 in.)	5.8 mm (0.228 in.)
Shift Drum Groove Width	6.05 ~ 6.20 mm (0.2382 ~ 0.2441 in.)	6.3 mm (0.248 in.)

Special Tool - Bearing Puller: 57001-135
Outside Circlip Pliers: 57001-144
Bearing Puller Adapter: 57001-317
Flywheel & Pulley Holder: 57001-1605

Sealant - Kawasaki Bond (Silicone Sealant): 56019-120
Kawasaki Bond (Silicone Sealant): 92104-1063

8-6 CRANKSHAFT/TRANSMISSION

Crankcase Splitting

Crankcase Splitting

- Remove the engine (see Engine Removal/Installation chapter).
- Set the engine on a clean surface and hold the engine steady while parts are being removed.
- Remove:
 - Crankshaft Sensor (see Electrical System chapter)
 - Oil Hose (Cylinder Head ~ Lower Crankcase)
 - Clutch (see Clutch chapter)
 - External Shift Mechanism (see External Shift Mechanism Removal)
 - Starter Motor (see Electrical System chapter)
 - Oil Pump (see Engine Lubrication System chapter)
 - Alternator Rotor (see Electrical System chapter)
 - Oil Filter (see Engine Lubrication System chapter)
 - Oil Cooler (see Engine Lubrication System chapter)
- ★ If the crankshaft is to be removed, remove the pistons (see Engine Top End chapter).
- Hold the timing rotor [A] steady with the holder [B], and remove the timing rotor bolt [C] and the rotor.
Special Tool - Flywheel & Pulley Holder: 57001-1605

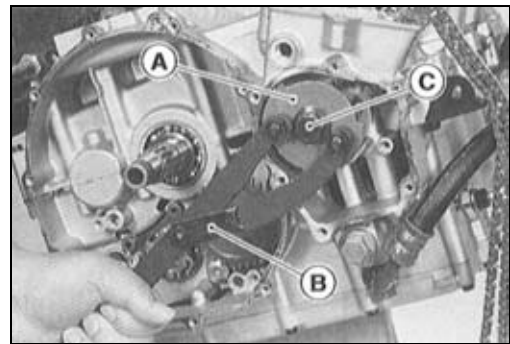

- Remove the upper crankcase bolts.
 - First loosen the 6 mm bolts.
 - 7 mm Bolts [A]
 - 6 mm Bolts [B]

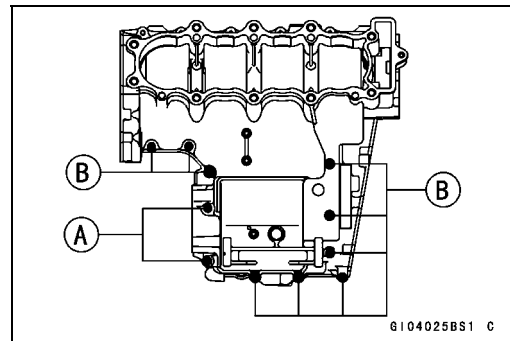

- Remove the oil pan, oil screen and oil pipes (see Engine Lubrication System chapter).
- Remove the lower crankcase bolts and brackets.
 - First loosen the 6 mm bolts.
 - 6 mm Bolts [A]
 - 8 mm Bolts [B]
- Tap lightly around the crankcase mating surface with a plastic mallet, and split the crankcase. Take care not to damage the crankcase.

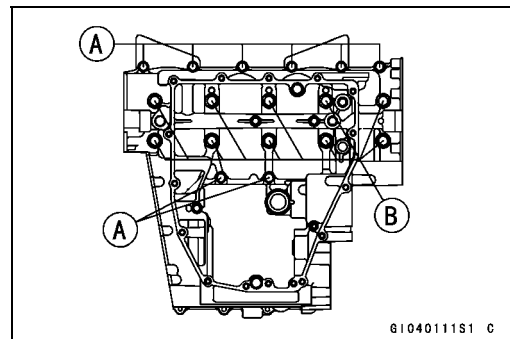

Crankcase Splitting

Crankcase Assembly

NOTE

○The upper and lower crankcase halves are machined at the factory in the assembled state, so the crankcase halves must be replaced as a set.

- With a high-flash point solvent, clean off the mating surfaces of the crankcases halves and wipe dry.
- Using compressed air, blow out the oil passages in the crankcase halves.

- Apply silicone sealant to the breather plate mating surface [A] 1 to 1.5 mm (0.04 ~ 0.06 in.) thick, wait until sealant dries, and then install the breather plate [B].

Sealant - Kawasaki Bond (Silicone Sealant): 92104-1063

- Apply a non-permanent locking agent to the threads and tighten the bolts [C].

Torque - Breather Plate Bolts: 9.8 N·m (1.0 kgf·m, 87 in·lb)

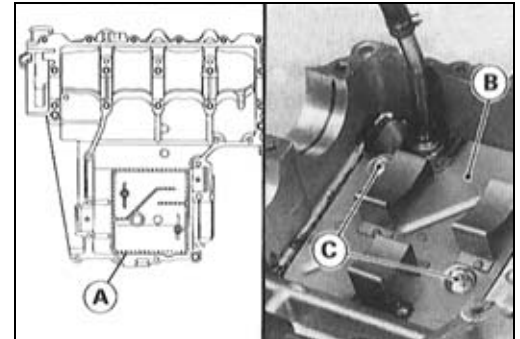

- Install:
 - Crankshaft and Connecting Rods
 - Camshaft Chain [A]
 - Transmission Shaft and Gears
 - Dowel Pins [B]
 - Shift Drum
 - Shift Forks and Shift Rods
- Before fitting the lower case on the upper case, check the following.
 - Be sure to hang the camshaft chain on the crankshaft.
 - Check to see that the shift drum and transmission gears are in the neutral position.

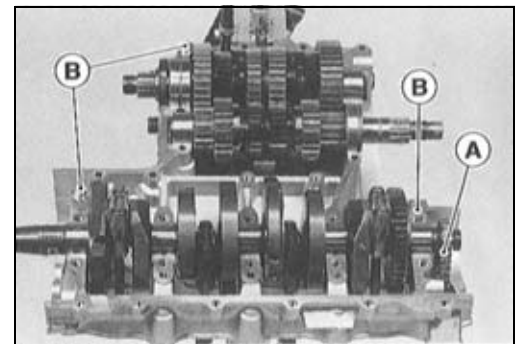

- Apply silicon sealant [A] to the mating surface of the lower crankcase half.

Sealant - Kawasaki Bond (Silicone Sealant): 92104-1063

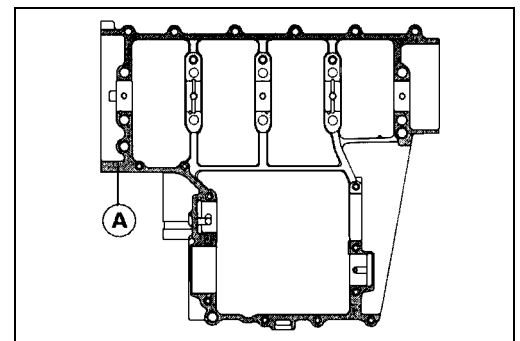

CAUTION

Do not apply silicone sealant around the crankshaft main bearing inserts, and oil passage holes.

8-8 CRANKSHAFT/TRANSMISSION

Crankcase Splitting

- Tighten the lower crankcase bolts, using the following steps.
- Following the sequence numbers on the lower crankcase half, tighten the 8 mm bolts [1 ~ 10].

Torque - Crankcase 8 mm Bolts: 30 N·m (3.0 kgf·m, 22 ft·lb)

- Install the brackets [A] and tighten the 6 mm bolts [B].

Torque - Crankcase (L38 mm) 6 mm Bolts: 18 N·m (1.8 kgf·m, 13 ft·lb)

- Tighten the 6 mm bolts [C].

Torque - Crankcase 6 mm Bolts: 12 N·m (1.2 kgf·m, 104 in·lb)

- Tighten the upper crankcase bolts, in the order listed.

Torque - Crankcase 7 mm Bolts [A]: 20 N·m (2.0 kgf·m, 14.5 ft·lb)

Crankcase 6 mm Bolts [B]: 12 N·m (1.2 kgf·m, 104 in·lb)

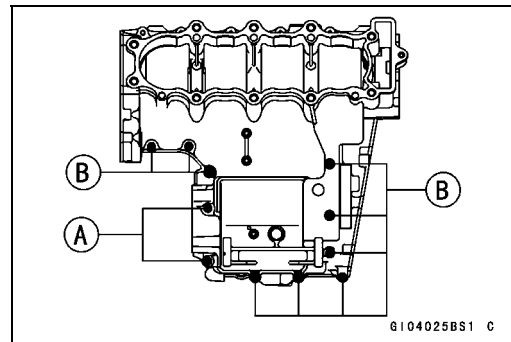
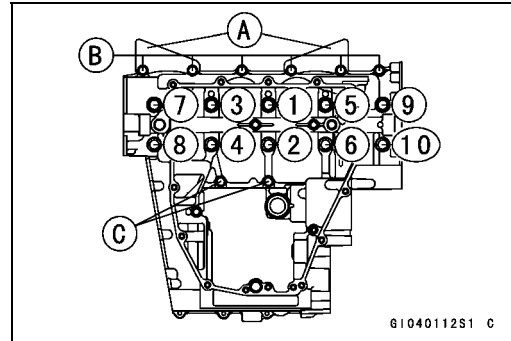

- After tightening all crankcase bolts, check the following items.
- Crankshaft and transmission shafts turn freely.
- While spinning the output shaft, gears shift smoothly from the 1st to 6th gear, and 6th to 1st.
- When the output shaft stays still, the gear can not be shifted to 2nd gear or other higher gear positions.

Crankshaft and Connecting Rods

Crankshaft Removal

- Split the crankcase (see Crankcase Splitting).
- Remove the crankshaft.

Crankshaft Installation

CAUTION

If the crankshaft, bearing inserts, or crankcase halves are replaced with new ones, select the bearing inserts and check clearance with a plastigage (press gauge) before assembling engine to be sure the correct bearing inserts are installed.

- Apply engine oil to the crankshaft main bearing inserts.
- Install the crankshaft with the camshaft chain [A] hanging on it.

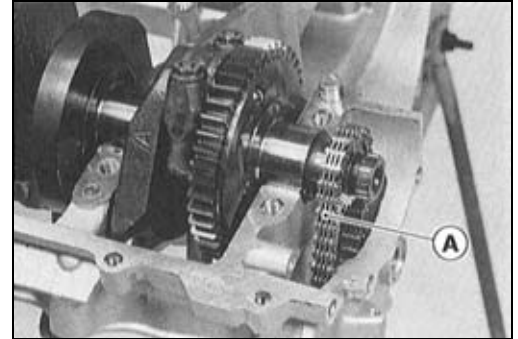

Connecting Rod Removal

- Split the crankcase (see Crankcase Splitting).
- Remove the connecting rod nuts.
- Remove the crankshaft.

NOTE

○Mark and record the locations of the connecting rods and their big end caps so that they can be reassembled in their original positions.

- Remove the connecting rods from the crankshaft.

CAUTION

Discard the connecting rod bolts. To prevent damage to the crankpin surfaces, do not allow the connecting rod bolts to bump against the crankpins.

Connecting Rod Installation

CAUTION

To minimize vibration, the connecting rods should have the same weight mark.

- Big End Cap [A]
- Connecting Rod [B]
- Weight Mark, Alphabet [C]
- Diameter Mark (Around Weight Mark) [D]: "○" or no mark

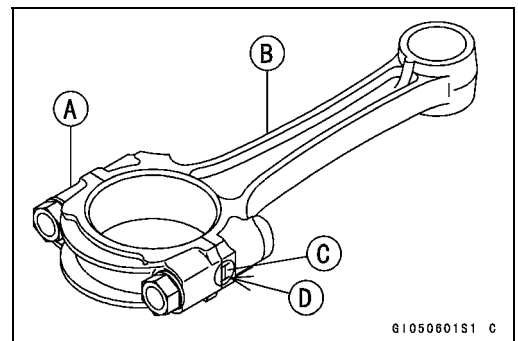

8-10 CRANKSHAFT/TRANSMISSION

Crankshaft and Connecting Rods

CAUTION

If the connecting rods, big end bearing inserts, or crankshaft are replaced with new ones, select the bearing insert and check clearance with a plasti-gage (press gauge) before assembling engine to be sure the correct bearing inserts are installed.

CAUTION

The connecting rod bolts are designed to stretch when tightened. Never reuse them.

- Replace the connecting rod big end bolts and nuts with new ones.
- Apply engine oil to the inner surface of upper and lower bearing inserts [A].
- Apply a small amount of the engine oil to the threads [B] and seating surface [C] of the connecting rod nuts.

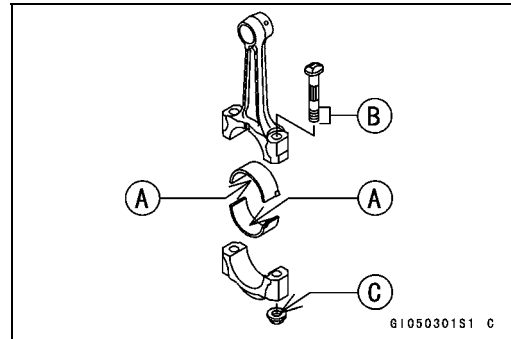

- The connecting rod big end is bolted using the “plastic region fastening method”.
- This method precisely achieves the needed clamping force without exceeding it unnecessarily, allowing the use of thinner, lighter bolts further decreasing connecting rod weight.
- There are two types of the plastic region fastening. One is a bolt length measurement method and other is a tightening torque method. Observe one of the following two, but the bolt length measurement method is preferable because this is a more reliable way to tighten the big end nuts.

(1) Bolt Length Measurement Method

- Be sure to clean the bolts, nuts, and connecting rods thoroughly with high-flash point solvent, because the new connecting rods, bolts, and nuts are treated with an anti-rust solution.

⚠ WARNING

Clean the bolts, nuts, and connecting rods in a well-ventilated area, and take care that there is no spark or flame anywhere near the working area. This includes any appliance with a pilot light. Because of the danger of highly flammable liquids, do not use gasoline or low-flash point solvents to clean them.

CAUTION

Immediately dry the bolts and nuts with compressed air after cleaning.
Clean and dry the bolts and nuts completely.

Crankshaft and Connecting Rods

- Install new bolts in reused connecting rods.
- Dent both bolt head and bolt tip with a punch as shown.
- Before tightening, use a point micrometer to measure the length of new connecting rod bolts and record the values to find the bolt stretch.

Connecting Rod [A]
 Dent here with a punch [B]
 Nuts [C]
 Fit micrometer pins into dents [D]

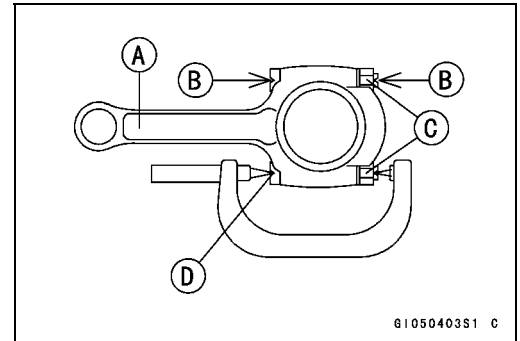

- Tighten the big end nuts until the bolt elongation reaches the length specified in the table.
- Check the length of the connecting rod bolts.
- ★ If the stretch is more than the usable range, the bolt has stretched too much. An overlongated bolt may break in use.

$$\text{Bolt Length after tightening} - \text{Bolt Length before tightening} = \text{Stretch}$$

Usable Range of Connecting Rod Bolt Stretch **0.30 ~ 0.40 mm (0.012 ~ 0.016 in.) (ZX600-J1 ~ J3)**

Usable Range of Connecting Rod Bolt Stretch **0.18 ~ 0.28 mm (0.007 ~ 0.011 in.) (ZX600-J4 ~)**

(2) Tightening Torque Method

- If you don't have a point micrometer, you may tighten the nuts using the "Tightening Torque Method".
- Be sure to clean the bolts, nuts, and connecting rods thoroughly with high-flash point solvent, because the new connecting rods, bolts, and nuts are treated with an anti-rust solution.

⚠ WARNING

Clean the bolts, nuts, and connecting rods in a well-ventilated area, and take care that there is no spark or flame anywhere near the working area. This includes any appliance with a pilot light. Because of the danger of highly flammable liquids, do not use gasoline or low-flash point solvents to clean them.

CAUTION

**Immediately dry the bolts and nuts with compressed air after cleaning.
 Clean and dry the bolts and nuts completely.**

8-12 CRANKSHAFT/TRANSMISSION

Crankshaft and Connecting Rods

- Apply a small amount of engine oil to the threads [A] and seating surface [B] of the connecting rod nuts.

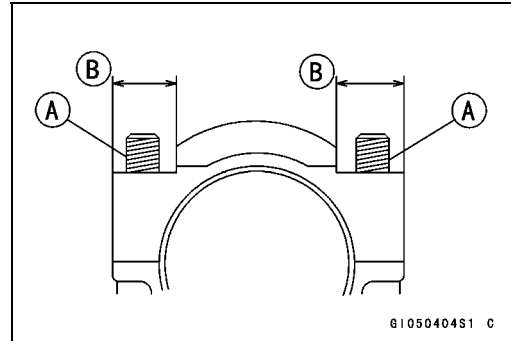

- First, tighten the nuts to the specified torque.
- Next, tighten the nuts **160°** more.
- Mark [A] the connecting rod big end caps and nuts so that nuts can be turned 160° [B] properly.

Torque + Angle-

15 N·m (1.5 kgf·m, 11 ft·lb) + 160° (ZX600-J1 ~ J3)

Torque + Angle-

15 N·m (1.5 kgf·m, 11 ft·lb) + 120° (ZX600-J4 ~)

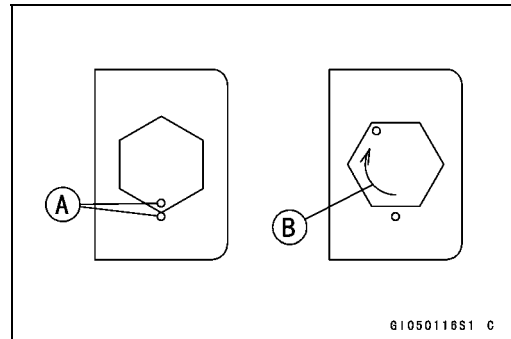

CAUTION

Since the friction force of the mating surface and thread portion of new nuts is different from that of used ones, the nut tightening torque should be changed as specified in the above table. Be careful not to overtighten the nuts.

Crankshaft/Connecting Rod Cleaning

- After removing the connecting rods from the crankshaft, clean them with a high-flash point solvent.
- Blow the crankshaft oil passages with compressed air to remove any foreign particles or residue that may have accumulated in the passages.

Connecting Rod Bend Inspection

- Remove the connecting rod big end bearing insets, and reinstall the connecting rod big end cap.
- Select an arbor [A] of the same diameter as the connecting rod big end, and insert the arbor through the connecting rod big end.
- Select an arbor of the same diameter as the piston pin and at least 100 mm (3.94 in.) long, and insert the arbor [B] through the connecting rod small end.
- On a surface plate, set the big-end arbor on V block [C].
- With the connecting rod held vertically, use a height gauge to measure the difference in the height of the arbor above the surface plate over a 100 mm (3.94 in.) length to determine the amount of connecting rod bend.
- ★ If connecting rod bend exceeds the service limit, the connecting rod must be replaced.

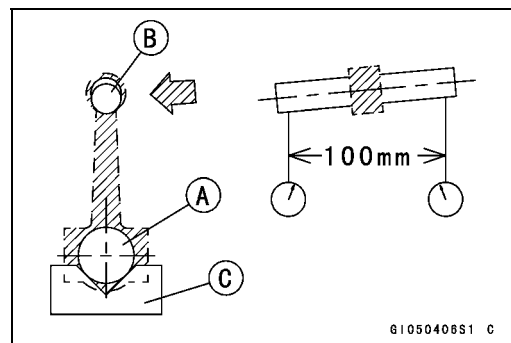

Connecting Rod Bend

Service Limit: TIR 0.2/100 mm (0.008/3.94 in.)

Crankshaft and Connecting Rods

Connecting Rod Twist Inspection

- With the big-end arbor [A] still on V block [C], hold the connecting rod horizontally and measure the amount that the arbor [B] varies from being paralleled with the surface plate over a 100 mm (3.94 in.) length of the arbor to determine the amount of connecting rod twist.
- ★ If connecting rod twist exceeds the service limit, the connecting rod must be replaced.

Connecting Rod Twist

Service Limit: TIR 0.2/100 mm (0.008/3.94 in.)

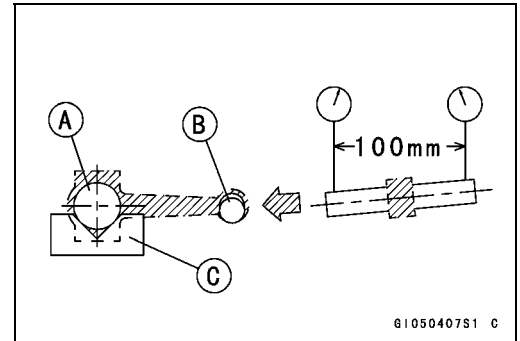

Connecting Rod Big End Side Clearance Inspection

- Measure connecting rod big end side clearance [A].
- Insert a thickness gauge [B] between the big end and either crank web to determine clearance.

Connecting Rod Big End Side Clearance

Standard: 0.13 ~ 0.33 mm (0.0051 ~ 0.0130 in.)

Service Limit: 0.5 mm (0.020 in.)

- ★ If the clearance exceeds the service limit, replace the connecting rod with new one and then check clearance again. If clearance is too large after connecting rod replacement, the crankshaft also must be replaced.

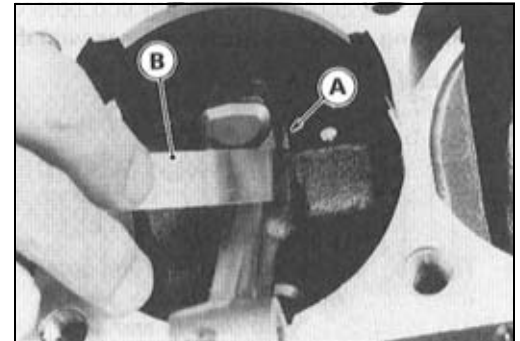

Connecting Rod Big End Bearing Insert/Crankpin Wear Inspection

- Measure the bearing insert/crankpin [B] clearance with plastigage [A].
- Tighten the big end nuts to the specified torque (see Connecting Rod Installation).

NOTE

- Do not move the connecting rod and crankshaft during clearance measurement.

Connecting Rod Big End Bearing Insert/Crankpin Clearance

Standard: 0.031 ~ 0.059 mm (0.0012 ~ 0.0023 in.)

Service Limit: 0.10 mm (0.004 in.)

- ★ If clearance is within the standard, no bearing replacement is required.
- ★ If clearance is between 0.060 mm (0.0024 in.) and the service limit [0.10 mm (0.004 in.)], replace the bearing inserts [A] with inserts painted black [B]. Check insert/crankpin clearance with the plastigage. The clearance may exceed the standard slightly, but it must not be less than the minimum in order to avoid bearing seizure.
- ★ If the clearance exceeds the service limit, measure the diameter of the crankpins.

Crankpin Diameter

Standard: 29.984 ~ 30.000 mm (1.1805 ~ 1.1811 in.)

Service Limit: 29.97 mm (1.180 in.)

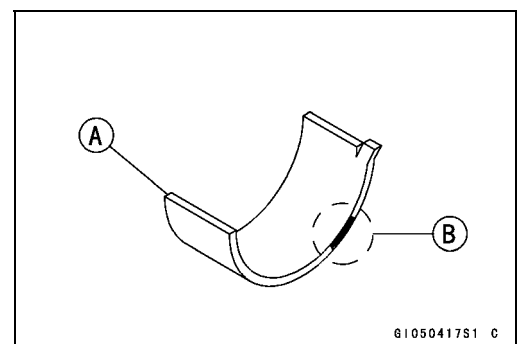
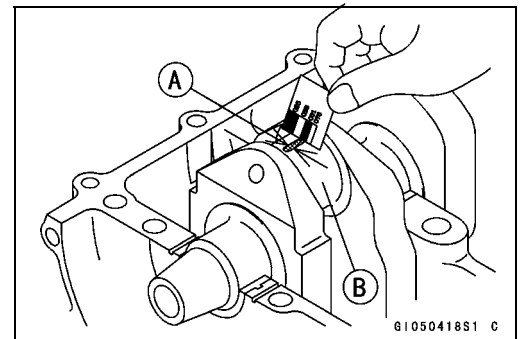

8-14 CRANKSHAFT/TRANSMISSION

Crankshaft and Connecting Rods

- ★ If any crankpin has worn past the service limit, replace the crankshaft with a new one.
- ★ If the measured crankpin diameters are not less than the service limit, but do not coincide with the original diameter markings on the crankshaft, make new marks on it.

Crankpin Diameter Marks

- None 29.984 ~ 29.994 mm (1.1805 ~ 1.1809 in.)
- 29.995 ~ 30.000 mm (1.1809 ~ 1.1811 in.)

△: Crankpin Diameter Marks, "○" mark or no mark.

- Measure the connecting rod big end bore diameter, and mark each connecting rod big end in accordance with the bore diameter.
- Tighten the big end nuts to the specified torque (see Connecting Rod Installation).

NOTE

○ The mark already on the big end should almost coincide with the measurement because of little wear.

Connecting Rod Big End Bore Diameter Marks

- None 33.000 mm ~ 33.008 mm (1.2992 ~ 1.2995 in.)
- 33.009 ~ 33.016 mm (1.2996 ~ 1.2998 in.)

Big End Cap [A]

Connecting Rod [B]

Weight Mark, Alphabet [C]

Diameter Mark (Around Weight Mark) [D]: "○" or no mark

- Select the proper bearing insert [A] in accordance with the combination of the connecting rod and crankshaft coding. Size Color [B]

Con-rod Big End Bore Diameter Marking	Crankpin Diameter Marking	Bearing Insert	
		Size Color	Part Number
None	○	Pink	92028-1880
None	None	Brown	92028-1879
○	○		
○	None	Black	92028-1878

- Install the new inserts in the connecting rod and check insert/crankpin clearance with the plastigage.

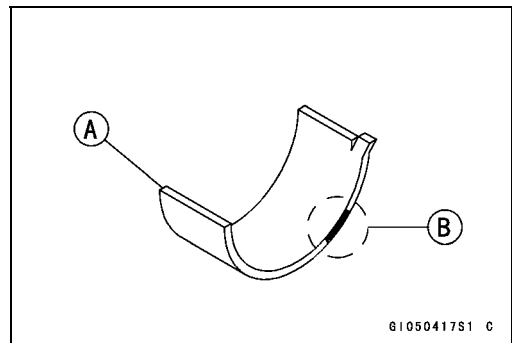
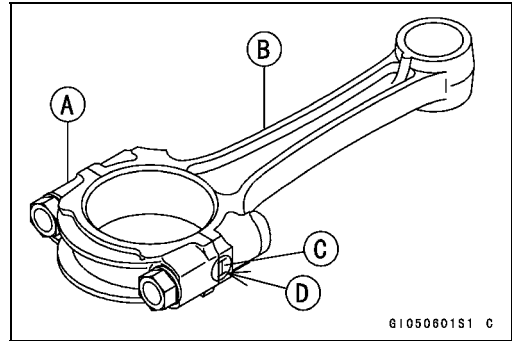
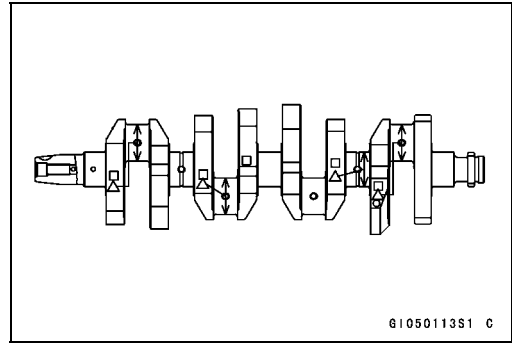

Crankshaft and Connecting Rods

Crankshaft Side Clearance Inspection

- Insert a thickness gauge [A] between the crankcase main bearing and the crank web at the No. 2 journal [B] to determine clearance.
- ★ If the clearance exceeds the service limit, replace the crankcase halves as a set.

NOTE

- The upper and lower crankcase halves are machined at the factory in the assembled state, so the crankcase halves must be replaced as a set.

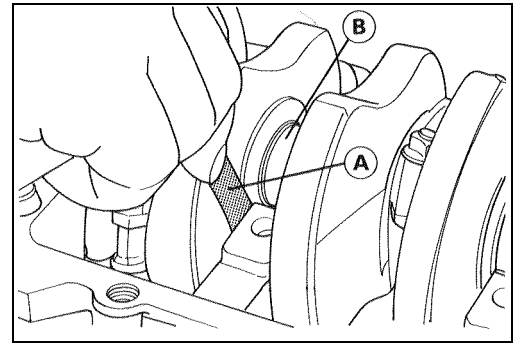

Crankshaft Side Clearance

- Standard:** 0.05 ~ 0.20 mm (0.002 ~ 0.008 in.)
- Service Limit:** 0.40 mm (0.016 in.)

Crankshaft Runout Inspection

- Measure the crankshaft runout.
- ★ If the measurement exceeds the service limit, replace the crankshaft.

Crankshaft Runout

- Standard:** TIR 0.02 mm (0.0008 in.) or less
- Service Limit:** TIR 0.05 mm (0.002 in.)

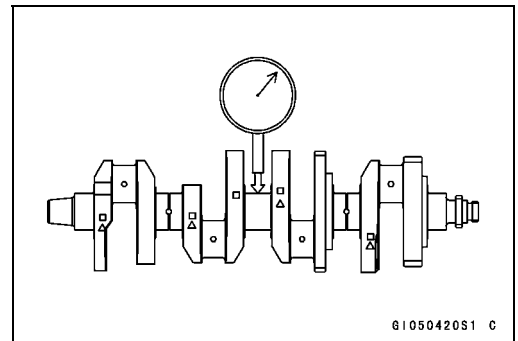

Crankshaft Main Bearing Insert/Journal Wear Inspection

- Using a plastigage (press gauge) [A], measure the bearing insert/journal [B] clearance.

NOTE

- Tighten the crankcase bolts to the specified torque (see Crankcase Assembly).
- Do not turn the crankshaft during clearance measurement.
- Journal clearance less than 0.025 mm (0.001 in.) can not be measured by plastigage, however, using genuine parts maintains the minimum standard clearance.

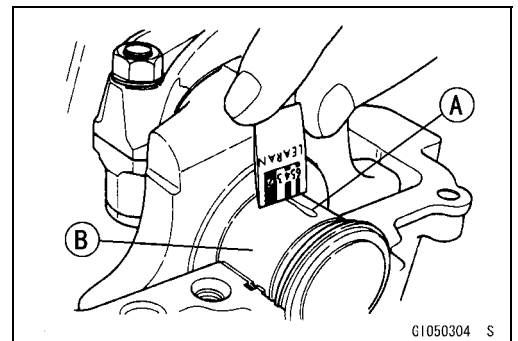

Crankshaft Main Bearing Insert/Journal Clearance

- Standard:** 0.014 ~ 0.038 mm (0.0006 ~ 0.0015 in.)
- Service Limit:** 0.07 mm (0.0028 in.)

- ★ If clearance is within the standard, no bearing replacement is required.
- ★ If clearance is between 0.039 mm (0.0015 in.) and the service limit (0.07 mm (0.003 in.)), replace the bearing inserts with inserts [A] painted blue [B]. Check insert/journal clearance with the plastigage. The clearance may exceed the standard slightly, but it must not be less than the minimum in order to avoid bearing seizure.
- ★ If clearance exceeds the service limit, measure the diameter of the crankshaft main journal.

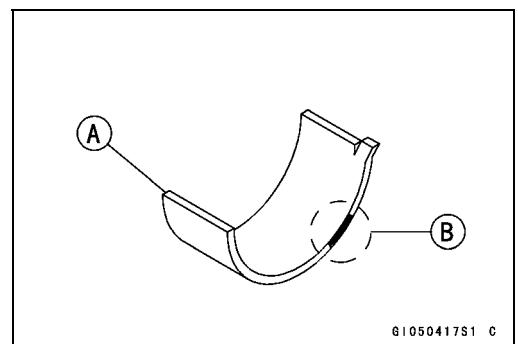

8-16 CRANKSHAFT/TRANSMISSION

Crankshaft and Connecting Rods

Crankshaft Main Journal Diameter

Standard: 29.984 ~ 30.000 mm (1.1805 ~ 1.1811 in.)

Service Limit: 29.96 mm (1.1795 in.)

- ★ If any journal has worn past the service limit, replace the crankshaft with a new one.
- ★ If the measured journal diameters are not less than the service limit, but do not coincide with the original diameter markings on the crankshaft, make new marks on it.

Crankshaft Main Journal Diameter Marks

None 29.984 ~ 29.994 mm (1.1805 ~ 1.1809 in.)

1 29.995 ~ 30.000 mm (1.1809 ~ 1.1811 in.)

□: Crankshaft Main Journal Diameter Marks, “1” mark or no mark.

- Measure the main bearing bore diameter, and mark the upper crankcase half in accordance with the bore diameter.

○: Crankcase Main Bearing Bore Diameter Marks, “○” mark or no mark.

NOTE

- Tighten the crankcase bolts to the specified torque (see Crankcase Assembly).
- The mark already on the upper crankcase half should almost coincide with the measurement.

Crankcase Main Bearing Bore Diameter Marks

○ 33.000 ~ 33.008 mm (1.2992 ~ 1.2995 in.)

None 33.009 ~ 33.016 mm (1.2996 ~ 1.2998 in.)

- Select the proper bearing insert [A] in accordance with the combination of the crankcase and crankshaft coding.
Size Color [B]

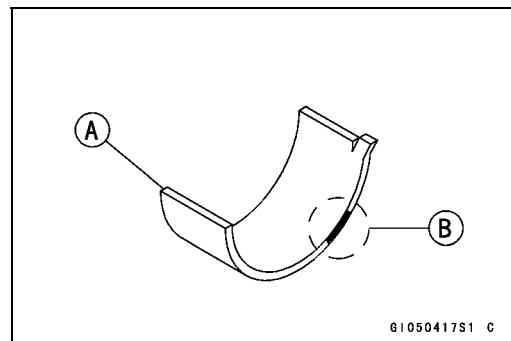
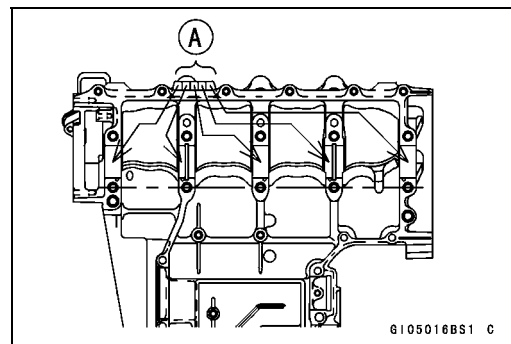
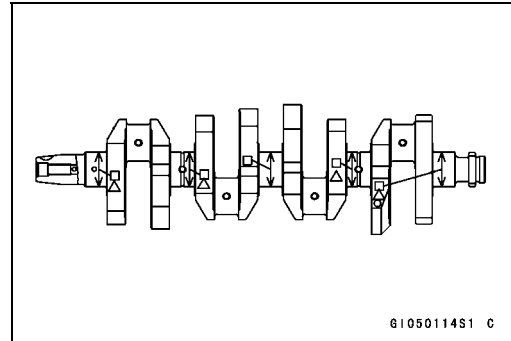

Crankcase Main Bearing Bore Diameter Marking	Crankshaft Main Journal Diameter Marking	Bearing Insert*		
		Size Color	Part Number	Journal Nos.
○	1	Brown	92028-1883	3, 5
			92028-1886	1, 2, 4
None	1	Black	92028-1882	3, 5
○	None		92028-1885	1, 2, 4
None	None	Blue	92028-1881	3, 5
			92028-1884	1, 2, 4

*The bearing inserts for Nos. 1, 2 and 4 journals have an oil groove, respectively.

- Install the new inserts in the crankcase halves and check insert/journal clearance with the plastigage.

Starter Motor Clutch

Starter Motor Clutch Removal/Installation

- Refer to the Alternator Rotor Removal and Installation in the Electrical System chapter.

Starter Motor Clutch Inspection

- Remove:
 - Alternator Cover (see Electrical System chapter)
 - Starter Idle Gear
- Turn the starter motor clutch gear [a] by hand. The starter motor clutch gear should turn clockwise [B] freely, but should not turn counterclockwise [C].
- ★ If the starter motor clutch does not operate as it should or if it makes noise, go to the next step.
- Disassemble the starter motor clutch, and visually inspect the clutch parts.
- ★ If there is any worn or damaged part, replace it.

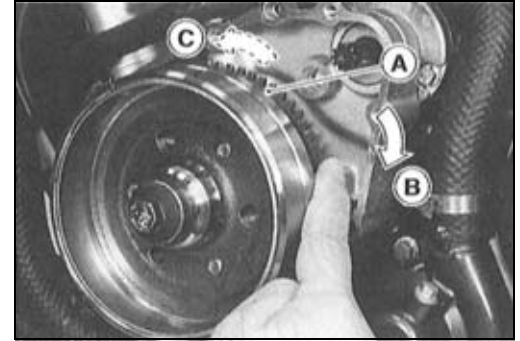

NOTE

○ Examine the starter motor clutch gear as well. Replace it if it is worn or damaged.

Starter Motor Clutch Disassembly

- Remove:
 - Alternator Rotor (see Electrical System chapter)
 - Starter Motor Clutch Bolts [A] and Starter Motor Clutch [B]



Starter Motor Clutch Assembly

- Apply a non-permanent locking agent to the threads of the starter motor clutch bolts and tighten them.
- Torque - Starter Motor Clutch Bolts: 34 N·m (3.5 kgf·m, 25 ft·lb)**

8-18 CRANKSHAFT/TRANSMISSION

Transmission

Shift Pedal Removal

- Mark the position of the shift lever on the shift shaft so that it can be installed later in the same position.
- Remove the shift lever and shift pedal.

Shift Pedal Installation

- Install the shift pedal [A] so that the distance between the center of the shift pedal and the center line of the shift rod [B] is about 3 mm by loosening the front and rear locknuts [C] and turning the rod.

NOTE

○The locknut next to the groove [D] of the rod has left-hand threads.

★If necessary, adjust the pedal position from the standard position to suit you as follows.

- Loosen the front and rear rod locknuts.
- Turn the rod to adjust the pedal position.
- Tighten the locknuts securely.

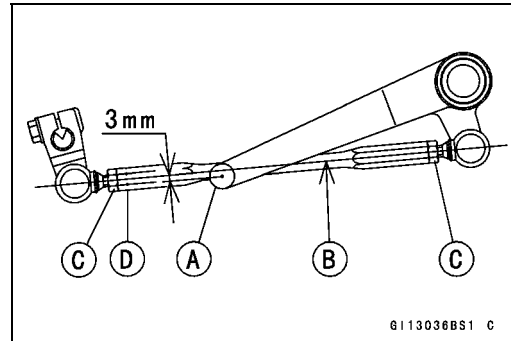

External Shift Mechanism Removal

- Remove:
 - Engine Oil (drain, see Engine Lubrication System chapter)
 - Shift Pedal (see Shift Pedal Removal)
 - Clutch (see Clutch chapter)
 - Bolts [A], Oil Pipe Holders [B], Oil Pipe [C] and O-ring

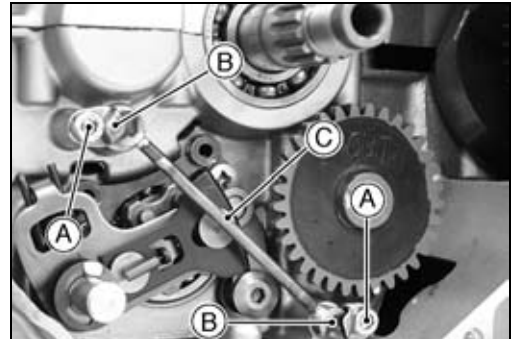

- Remove:
 - Shift Shaft [A]
 - Bolt [B]
 - Gear Positioning Lever [C] and Spring

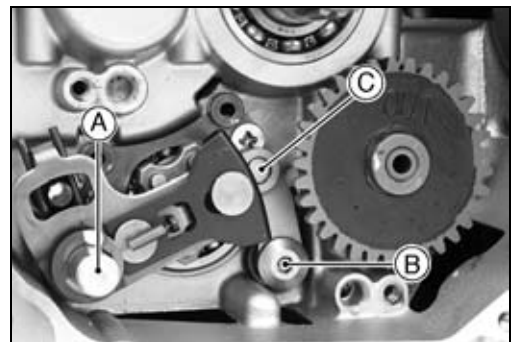

External Shift Mechanism Installation

- Apply a locking agent to the thread of the gear positioning lever mounting bolt.
- Install the gear positioning lever [A] as shown, and tighten the bolt.
 - Springs [B]
 - Collar [C]
 - Bolt [D]

Torque - Gear Positioning Lever Bolt: 12 N·m (1.2 kgf·m, 104 in·lb)

- Apply a locking agent to the thread of oil pipe holder bolt.
- Tighten the oil pipe holder bolts.

Torque - Oil Pipe Holder Bolts: 12 N·m (1.2 kgf·m, 104 in·lb)

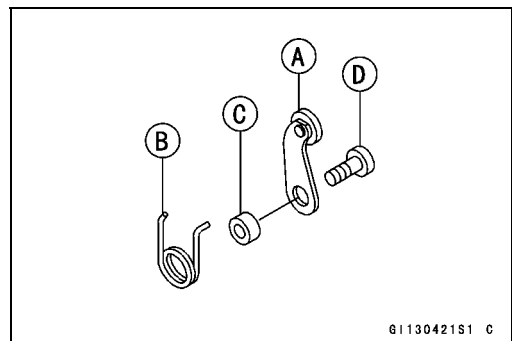

Transmission

External Shift Mechanism Inspection

- Examine the shift shaft [A] for any damage.
- ★ If the shaft is bent, straighten or replace it.
- ★ If the serration are damaged, replace the shaft.
- ★ If the springs [B] [C] are damaged in any way, replace them.
- ★ If the shift mechanism arm [D] is damaged in any way, replace the arm.

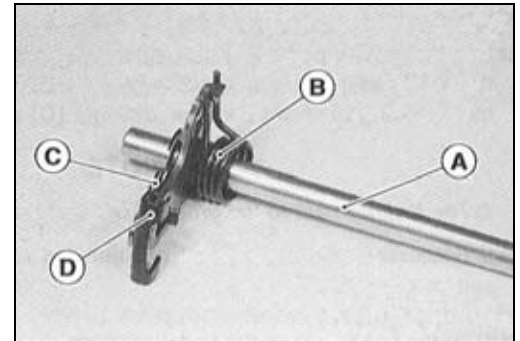

- Check the return spring pin [A] is not loose.
- ★ If it is loose, unscrew it, apply a non-permanent locking agent to the threads, and tighten it.

Torque - Shift Shaft Return Spring Pin: 28 N·m (2.9 kgf·m, 21 ft·lb)

- Check the gear positioning lever [B] and it's spring for breaks or distortion.
- ★ If the lever or spring are damaged in any way, replace them.
- Visually inspect the shift drum cam [C].
- ★ If they are badly worn or if they show any damage, replace it.

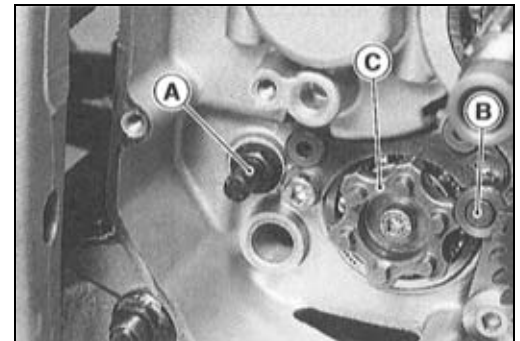

Transmission Shaft Removal

- Split the crankcase (see Crankcase Splitting).
- Remove the drive shaft [A] and output shaft [B].

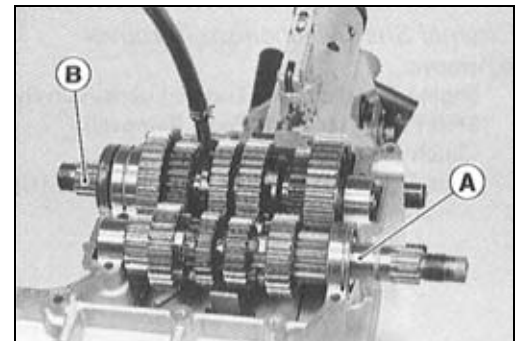

Transmission Shaft Installation

- Check to see that the set pins [A] and set rings [B] are in place.

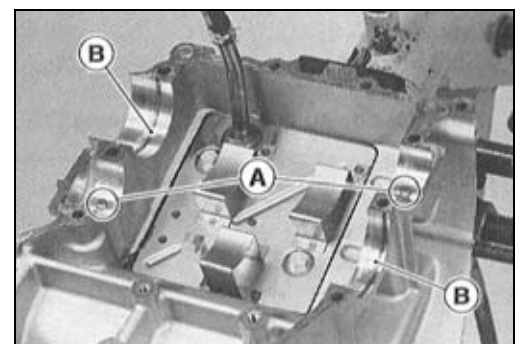

8-20 CRANKSHAFT/TRANSMISSION

Transmission

- Install the drive shaft and output shaft into the upper crankcase half.
- Apply engine oil to the sliding surfaces of the gears and bearings.
- The bearing set pins and rings must match properly with the holes or grooves in the bearing outer races. When they are properly matched, there is no clearance between the crankcase and the bearing outer races [A].

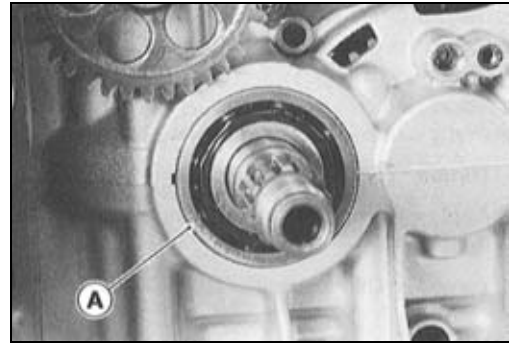

Transmission Shaft Disassembly

- Remove the transmission shafts (see Transmission Shaft Removal).
- Remove the circlips, disassemble the transmission shafts.

Special Tool - Outside Circlip Pliers: 57001-144

- The 5th gear [A] on the output shaft has three steel balls assembled into it for the positive neutral finder mechanism. Remove the 5th gear.
- Set the output shaft in a vertical position holding the 3rd gear [B].
- Spin the 5th gear quickly [C] and pull it off upward.

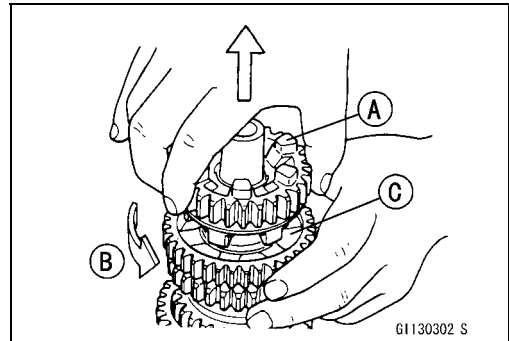

- Remove the ball bearing [A] from each shafts.

Special Tools - Bearing Puller: 57001-135 [B]

Bearing Puller Adapter: 57001-317 [C]

- Discard the bearing.

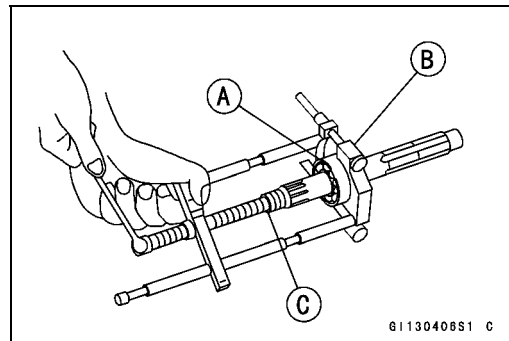

Transmission Shaft Assembly

- Install the ball bearing on the drive shaft with the groove toward the clutch side.
- Install the gear bushing [A] on the shafts with their oil holes [B] aligned.

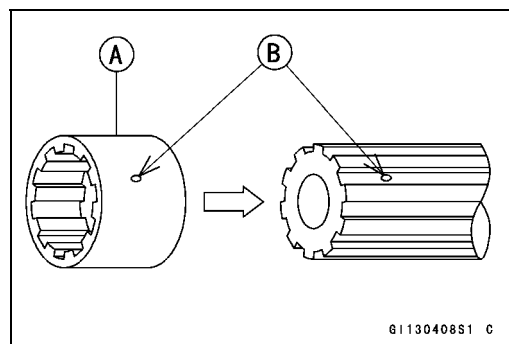

Transmission

- The drive shaft gears can be recognized by size: the gear with the smallest diameter is 1st gear, and the largest one is 6th gear. Be sure that all parts are put back in the correct sequence and all circlips and washers are properly in place.
- Install the 3rd/4th gear onto the drive shaft with their holes aligned.
- The output shaft gears can be recognized by size: the gear with the largest diameter is 1st gear, and the smallest one is 6th gear. Be sure that all parts are put back in the correct sequence and all circlips and washers are properly in place.
- Install the 5th and 6th gears onto the output shaft with their holes aligned.
- Fit the steel balls into the 5th gear holes in the output shaft as shown.
View A - A' (see CRANKSHAFT/TRANSMISSION 8-24)
[A] Gear (5th)
[B] Shaft
[C] Steel Balls

CAUTION
Do not apply grease to the steel balls to hold them in place. This will cause the positive neutral finder mechanism to malfunction.

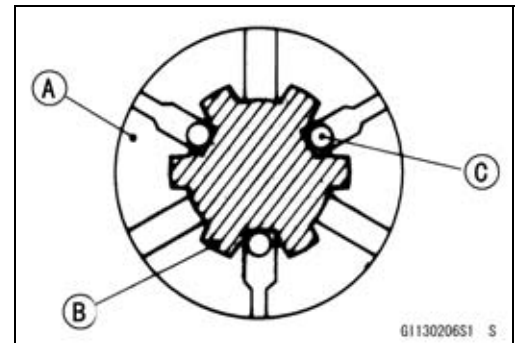

- Check the ball-locking effect that the 5th gear does not come out of the output shaft when moving it up and down by hand.

- Replace any circlip that were removed with new ones.
- Install the circlips [A] so that opening [B] is aligned with a spline groove [C].
- Check that each gear spins or slides freely on the transmission shafts without binding after assembly.

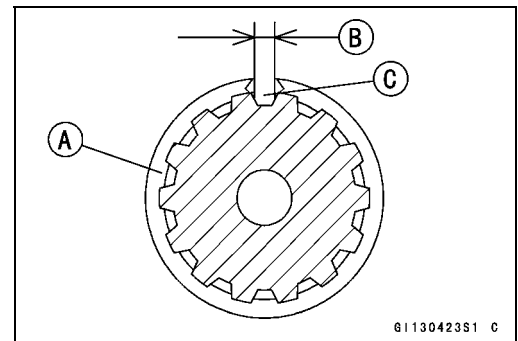

Shift Drum and Fork Removal

- Remove:
 - Clutch (see Clutch chapter)
 - Oil Pan (see Engine Lubrication System chapter)
 - External Shift Mechanism (see External Shift Mechanism Removal)
 - Gear Positioning Lever
 - Bolt [A] and Screw [B]
 - Shift Drum Bearing Holder [C]
- Pull out the shift rods [D], and take off the shift forks.
- Pull out the shift drum [E].

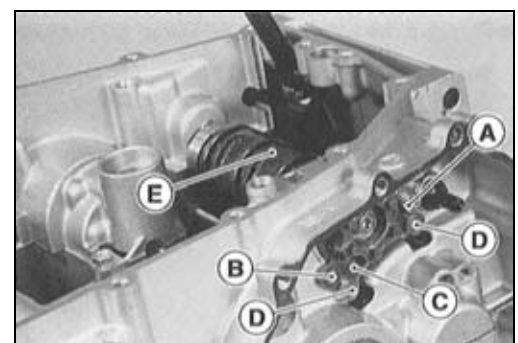

8-22 CRANKSHAFT/TRANSMISSION

Transmission

Shift Drum and Fork Installation

- Set the transmission gears in the neutral position.
- Install the shift drum so that the punch mark [A] on it faces oil pan side.

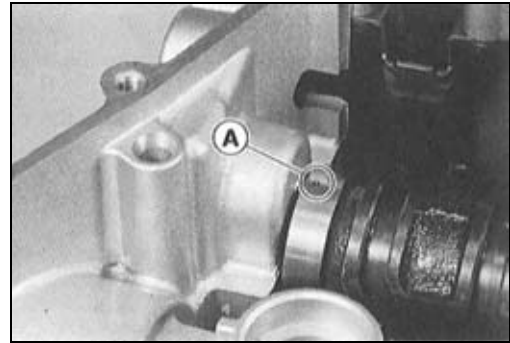

- Install the forks as shown.
- Position the one with shortest ears [A] on the drive shaft and place the pin in the center groove in the shift drum [B].
- The two forks [C] on the output shaft are identical.
- Install the shift rods [D], noting the groove position. The rods are identical.
- Apply a non-permanent locking agent to the threads of the shift drum bearing holder screw, and tighten it and bolt.

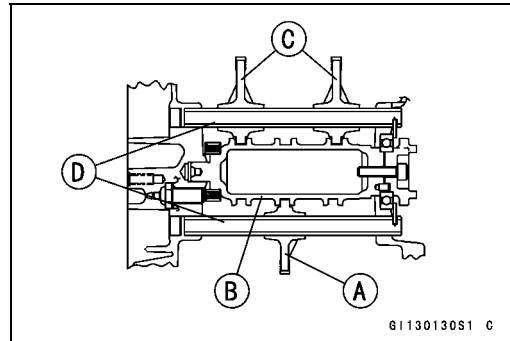

G1130130S1 C

Torque - Shift Drum Bearing Holder Bolt: 12 N·m (1.2 kgf·m, 104 in·lb)

Shift Drum Bearing Holder Screw: 4.9 N·m (0.5 kgf·m, 43 in·lb)

Shift Drum Disassembly

- Remove the shift drum (see Shift Drum and Fork Removal).
- While holding the shift drum with a vise, remove the shift drum cam holder bolt.

[A] Shift Drum Cam Holder Bolt
[B] Dowel Pin

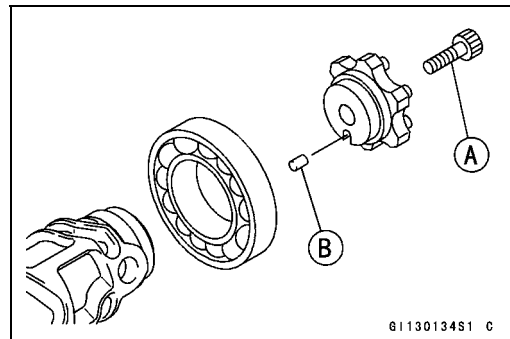

G1130134S1 C

Shift Drum Assembly

- Be sure to install the dowel pin.
- Apply a non-permanent locking agent to the threads of the shift drum cam holder bolt, and tighten it.

Torque - Shift Drum Cam Holder Bolt: 12 N·m (1.2 kgf·m, 104 in·lb)

Shift Fork Bending Inspection

- Visually inspect the shift forks, and replace any fork that is bent. A bent fork could cause difficulty in shifting, or allow the transmission to jump out of gear when under power. 90° [A]

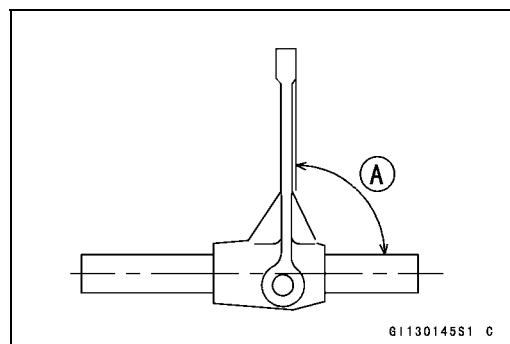

G1130145S1 C

Transmission

Shift Fork/Gear Groove Wear Inspection

- Measure the thickness of the shift fork ears [A], and measure the width [B] of the gear grooves.
- ★ If the thickness of a shift fork ear is less than the service limit, the shift fork must be replaced.

Shift Fork Ear Thickness

Standard: 5.9 ~ 6.0 mm (0.2323 ~ 0.2362 in.)

Service Limit: 5.8 mm (0.228 in.)

- ★ If the gear groove is worn over the service limit, the gear must be replaced.

Gear Groove Width

Standard: 6.05 ~ 6.15 mm (0.2382 ~ 0.2421 in.)

Service Limit: 6.25 mm (0.246 in.)

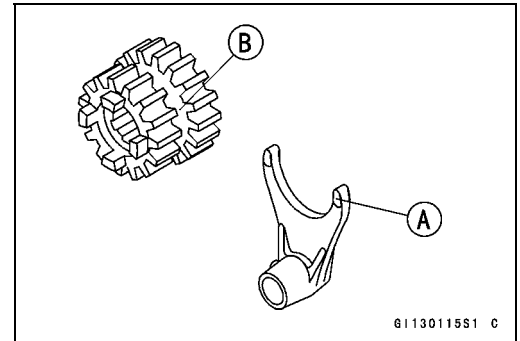

Shift Fork Guide Pin/Drum Groove Wear Inspection

- Measure the diameter of each shift fork guide pin [A], and measure the width [B] of each shift drum groove.
- ★ If the guide pin on any shift fork is less than the service limit, the fork must be replaced.

Shift Fork Guide Pin Diameter

Standard: 5.9 ~ 6.0 mm (0.2323 ~ 0.2362 in.)

Service Limit: 5.8 mm (0.228 in.)

- ★ If any shift drum groove is worn over the service limit, the drum must be replaced.

Shift Drum Groove Width

Standard: 6.05 ~ 6.20 mm (0.2382 ~ 0.2441 in.)

Service Limit: 6.30 mm (0.248 in.)

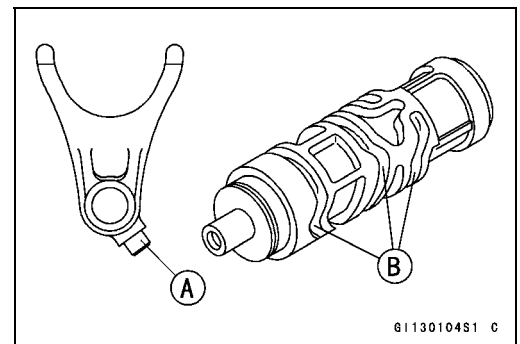

Gear Dog and Gear Dog Hole Damage Inspection

- Visually inspect the gear dogs [A] and gear dog holes [B].
- ★ Replace any damaged gears or gears with excessively worn dogs or dog holes.

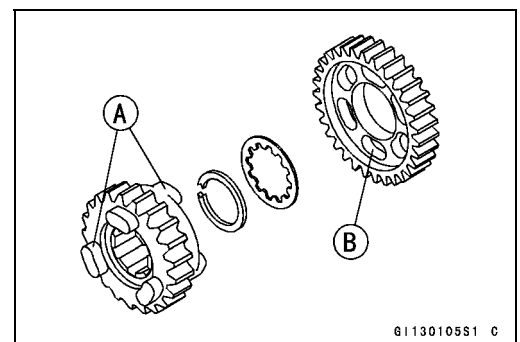

8-24 CRANKSHAFT/TRANSMISSION

Transmission

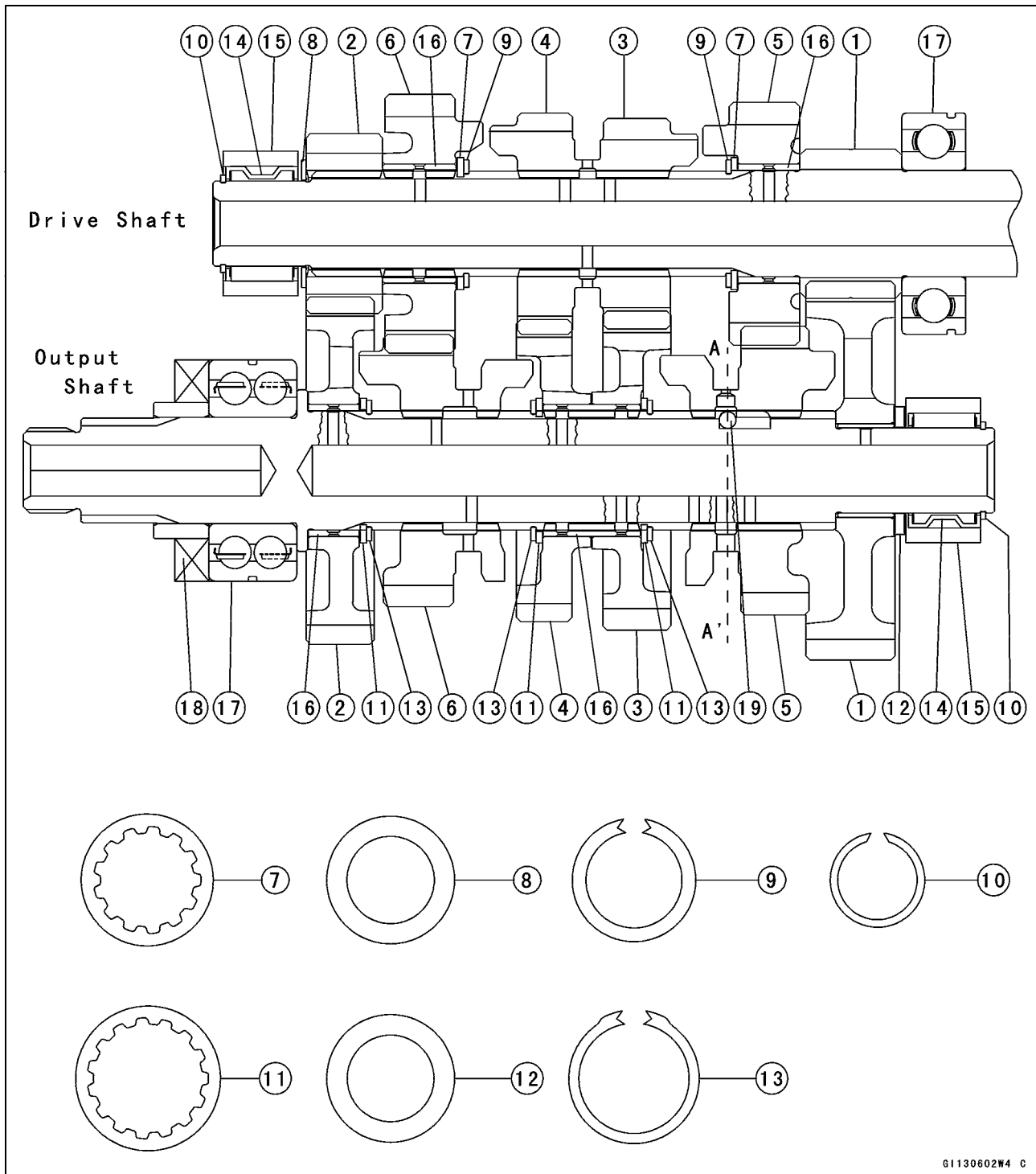

G1130602W4 C

- | | |
|-------------------------|------------------------|
| 1. 1st Gear | 11. Toothed Washer |
| 2. 2nd Gear | 12. Thrust Washer |
| 3. 3rd Gear | 13. Circlip |
| 4. 4th Gear | 14. Needle Bearing |
| 5. 5th Gear | 15. Bearing Outer Race |
| 6. 6th (Top) Gear | 16. Bushing |
| 7. Toothed Washer | 17. Ball Bearing |
| 8. Thrust Washer (Thin) | 18. Oil Seal |
| 9. Circlip | 19. Steel Ball |
| 10. Circlip | |

Wheels/Tires

Table of Contents

Exploded View	9-2
Specifications	9-3
Wheels (Rims)	9-4
Front Wheel Removal	9-4
Front Wheel Installation	9-4
Rear Wheel Removal	9-5
Rear Wheel Installation	9-6
Wheel Inspection	9-7
Axle Inspection	9-7
Balance Inspection	9-7
Balance Adjustment	9-8
Balance Weight Removal	9-8
Balance Weight Installation	9-8
Tires	9-11
Air Pressure Inspection/Adjustment	9-11
Tire Inspection	9-11
Tire Removal	9-12
Tire Installation	9-12
Tire Repair	9-14
Hub Bearing	9-15
Hub Bearing Removal	9-15
Hub Bearing Installation	9-15
Hub Bearing Inspection	9-16
Hub Bearing Lubrication	9-16

9-2 WHEELS/TIRES

Exploded View

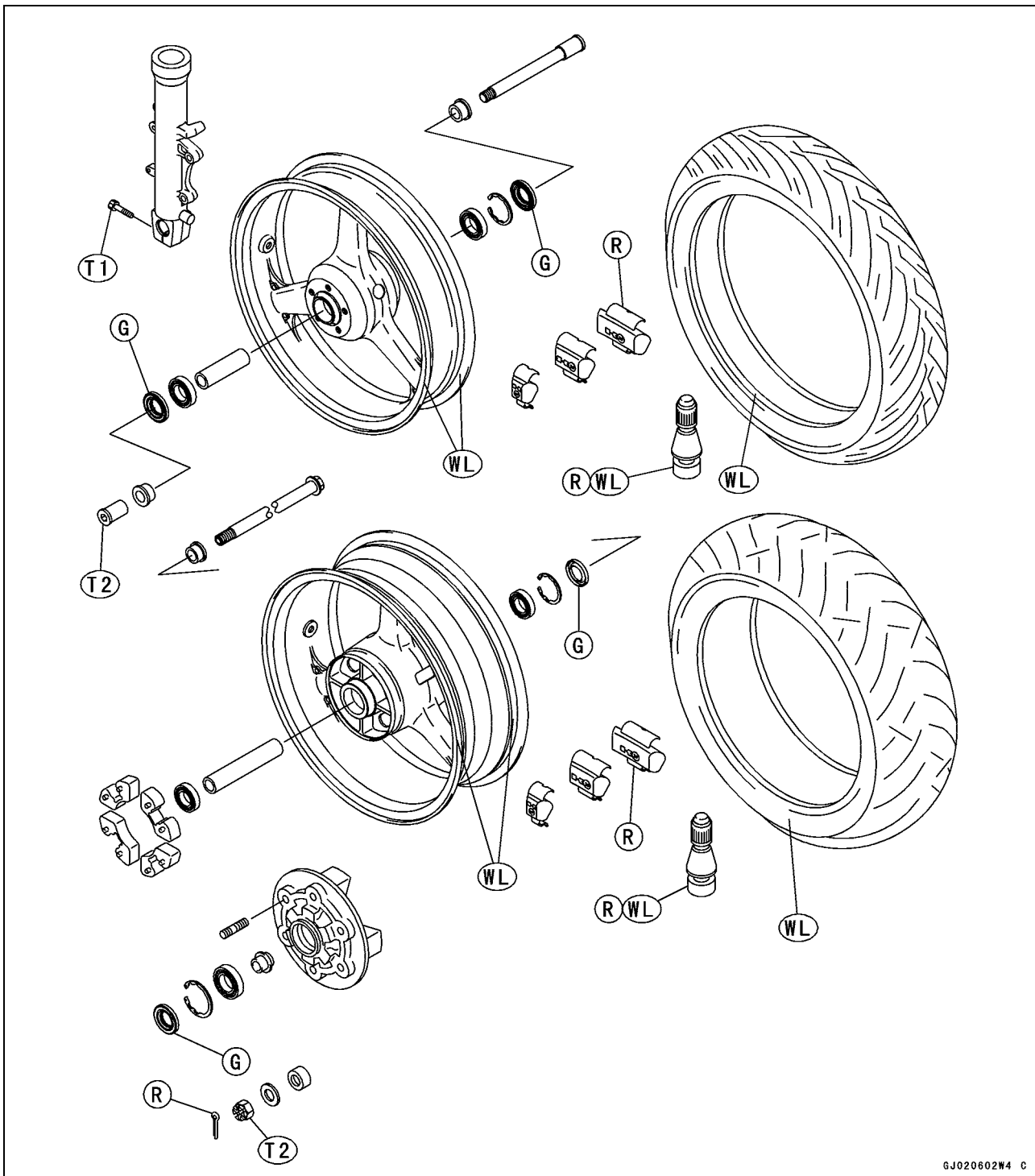

GJ020602W4 C

T1: 20 N·m (2.0 kgf·m, 14.5 ft·lb)

T2: 127 N·m (13 kgf·m, 94 ft·lb)

G: Apply grease.

R: Replacement Parts

WL: Apply soap and water solution or rubber lubricant.

Specifications

Item	Standard	Service Limit
Wheels (Rims)		
Rim Size:		
Front	J17M/C × MT3.50	---
Rear	J17 × MT5.50	---
Rim runout:		
Axial	TIR 0.5 mm (0.020 in.) or less	TIR 1 mm (0.040 in.)
Radial	TIR 0.8 mm (0.031 in.) or less	TIR 1 mm (0.040 in.)
Axle runout/100 mm (3.9 in.)	0.05 mm (0.002 in.) or less	0.2 mm (0.008 in.)
Wheel balance	10 g (0.35 oz) or less	---
Balance weights	10 g (0.35 oz), 20 g (0.70 oz), 30 g (1.05 oz)	---
Tires		
Air pressure: (when cold)		
Front	Up to 182 kg (401 lb) load: 250 kPa (2.5 kgf/cm ² 36 psi)	---
Rear	Up to 182 kg (401 lb) load: 290 kPa (2.9 kgf/cm ² , 41 psi)	---
Tread depth:		
Front	DUNLOP: 4.0 mm (0.16 in.) MICHELIN: 3.8 mm (0.15 in.)	1 mm (0.04 in.) (DE) 1.6 mm (0.06 in.)
Rear	DUNLOP: 5.4 mm (0.21 in.) MICHELIN: 5.6 mm (0.22 in.)	Up to 130 km/h (80 mph): 2 mm (0.08 in.) Over 130 km/h (80 mph): 3 mm (0.12 in.)
Standard tires:	Make, Type	Size
Front	DUNLOP, D207F MICHELIN Pilot SPORT M BRIDGESTONE, BATTLAX BT010F RADIAL PIRELLI, MTR21 Corsa METZELER, MEZ3 Front Racing	120/65 ZR17 (56 W) (ZX600-J1 ~ J2) 120/65 ZR17 M/C (56 W) (ZX600-J3 ~)
Rear	DUNLOP, D207T MICHELIN Pilot SPORT M BRIDGESTONE, BATTLAX BT010R RADIAL G PIRELLI, MTR22 Corsa METZELER, MEZ3 Racing	180/55 ZR17 (73 W) (ZX600-J1 ~ J2) 180/55 ZR17 M/C (73 W) (ZX600-J3 ~)

DE: Germany

Special Tools - Jack: 57001-1238

Inside Circlip Pliers: 57001-143

Bearing Driver Set: 57001-1129

Bearing Remover Shaft, ϕ 13: 57001-1377

Bearing Remover Head, ϕ 25 × ϕ 28: 57001-1346

⚠ WARNING

Use the same manufacturer's tires on both front and rear wheels.

9-4 WHEELS/TIRES

Wheels (Rims)

Front Wheel Removal

- Remove:
 - Lower Fairing (see Frame chapter)
 - Brake Caliper Mounting Bolts [A]

- Loosen:
 - Right Side Axle Clamp Bolts [A]
 - Axle [B]

- Raise the front wheel off the ground.
 - Special Tool - Jack: 57001-1238**
- Pull out the axle to the right and drop the front wheel out of the forks.

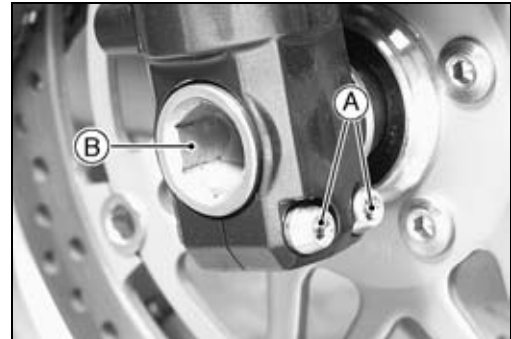
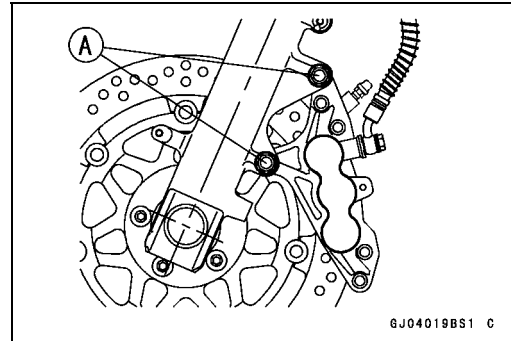

CAUTION
Do not lay the wheel down on one of the discs. This can damage or warp the disc. Place blocks under the wheel so that the disc does not touch the ground.

Front Wheel Installation

NOTE

○The direction of the wheel rotation [A] is shown by an arrow [B] on the wheel spoke.

- Check the wheel rotation mark on the front wheel and install it.
- Fit the collars on the both sides of the hub.
- Tighten the axle nut.

Torque - Front Axle Nut: 127 N·m (13 kg·m, 94 ft·lb)

- Before tightening the clamp bolts on the right front fork leg, pump the front fork up and down 4 or 5 times to all on the right front fork leg to seat on the front axle.

NOTE

○Put a block in front of the front wheel to stop moving.

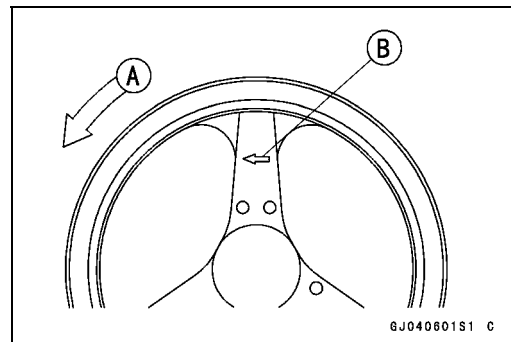

Wheels (Rims)

- Tighten the axle clamp bolts [A] on the right fork leg first.
Torque - Front Axle Clamp Bolts: 20 N·m (2.0 kg·m, 14.5 ft·lb)
- Check the clearance [B] between the right fork leg [D] and collar [C] with the thickness gauge.
Standard: 1.5 mm (0.06 in.)
Usable range: 0.5 ~ 2.8 mm (0.02 ~ 0.11 in.)
- ★ If the clearance is out of this range, remove the front wheel again and check the axle, wheel hub and other related parts for damage.
- Tighten the axle clamp bolts on the left fork leg.
Torque - Front Axle Clamp Bolts: 20 N·m (2.0 kg·m, 14.5 ft·lb)
- Install the front brake calipers (see Brakes chapter).
- Check the front brake effectiveness (see Brakes chapter).

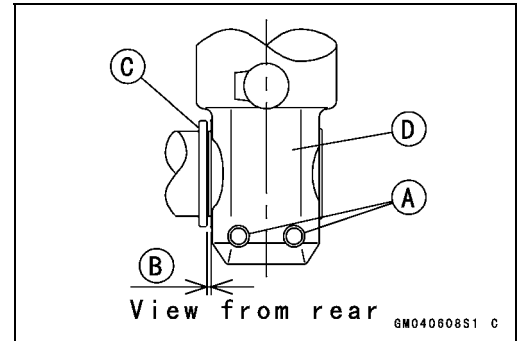

⚠ WARNING

Do not attempt to drive the motorcycle until a full brake lever is obtained by pumping the brake lever until the pads are against the disc. The brake will not function on the first application of the lever if this is not done.

Rear Wheel Removal

- Remove the lower fairings (see Frame chapter).
 - Using the jack [A], raise the rear wheel off the ground.
 - Adjust the length of the jack legs [B], situate the motorcycle so that it is perpendicular to the ground.
- Special Tool - Jack: 57001-1238**

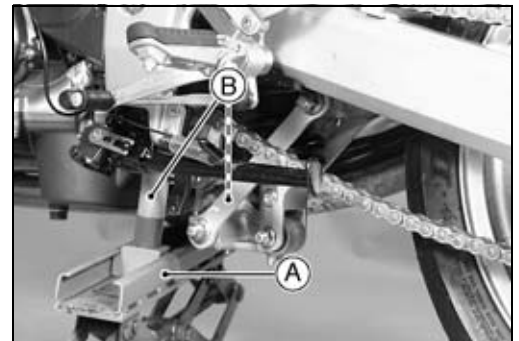

- Remove:
 Cotter Pin [A]
 Axle Nut [B]
 Axle [C]

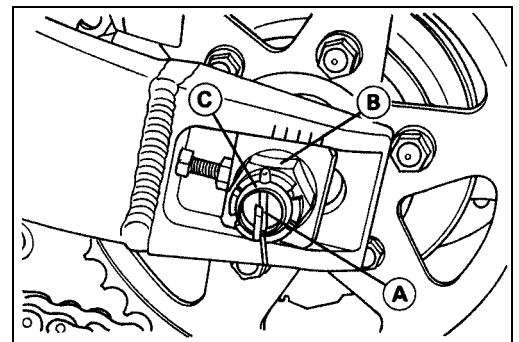

9-6 WHEELS/TIRES

Wheels (Rims)

- Remove the rear caliper.
- Remove the chain cover.
- Remove the drive chain [A] from the rear sprocket toward the left.
- Move the rear wheel back and remove it.

CAUTION

Do not lay the wheel on the ground with the disc facing down. This can damage or warp the disc. Place blocks under the wheel so that the disc does not touch the ground.

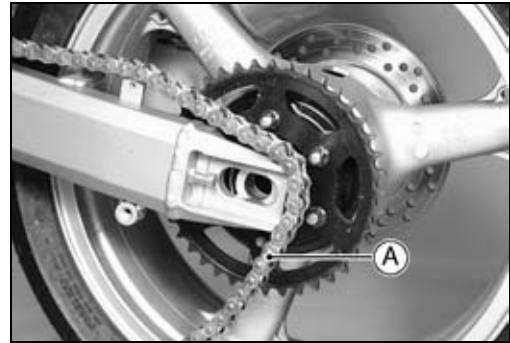

Rear Wheel Installation

- Engage the drive chain with the rear sprocket.
- Install the caliper bracket [A] onto the swingarm stop [B].
- Insert the axle from the right side of the wheel, and tighten the axle nut.

Torque - Rear Axle Nut: 127 N·m (13 kg·m, 94 ft·lb)

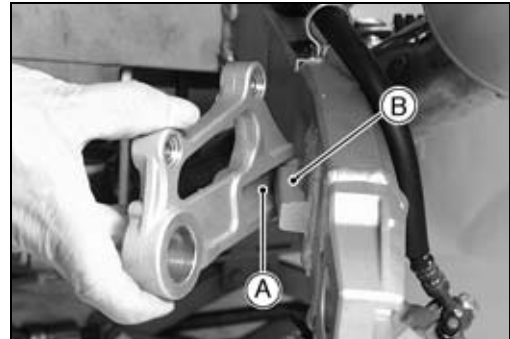

- Install a new cotter pin.

NOTE

- When inserting the cotter pin, if the slots in the nut do not align with the cotter pin hole in the axle, tighten the nut clockwise [B] up to next alignment.
- It should be within 30 degree.
- Loosen once and tighten again when the slot goes past the nearest hole.

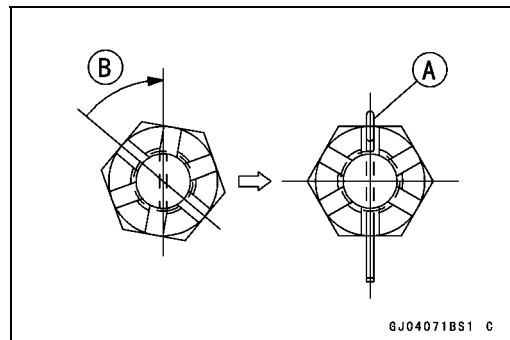

- Bend the cotter pin [A] over the nut.
- Adjust the drive chain slack after installation (see Final Drive chapter).
- Install the rear caliper and the chain cover.
- Check the rear brake effectiveness.

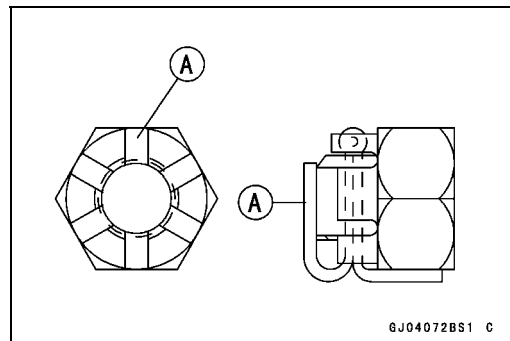

⚠ WARNING

Do not attempt to drive the motorcycle until a full brake pedal is obtained by pumping the brake pedal until the pads are against the disc. The brake will not function on the first application of the pedal if this is not done.

Wheels (Rims)

Wheel Inspection

- Raise the front/rear wheel off the ground.
- Special Tool - Jack: 57001-1238**
- Spin the wheel lightly, and check for roughness or binding.
- ★ If roughness or binding is found, replace the hub bearings.
- Inspect the wheel for small cracks, dents, bending, or warp.
- ★ If there is any damage to the wheel, replace the wheel.
- Measure the rim runout, radial [B] and axial [A], with a dial gauge with tire installed.
- ★ If the rim runout exceeds the service limit, check the hub bearings.
- ★ If the problem is not due to the bearings, replace the wheel.

Rim Runout (with tire installed)

Standard:

Axial	TIR 0.5 mm (0.02 in.) or less
Radial	TIR 0.8 mm (0.03 in.) or less

Service Limit:

Axial	TIR 1 mm (0.04 in.)
Radial	TIR 1 mm (0.04 in.)

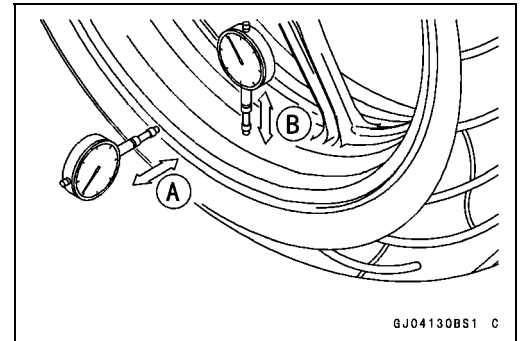

⚠ WARNING

Never attempt to repair a damaged wheel. If there is any damage besides wheel bearings, the wheel must be replaced to insure safe operational condition.

Axle Inspection

- Visually inspect the front and rear axle for damages.
- ★ If the axle is damaged or bent, replace it.
- Place the axle in V blocks that are 100 mm (3.94 in.) [A] apart, and set a dial gauge [B] on the axle at a point halfway between the blocks. Turn [C] the axle to measure the runout. The difference between the highest and lowest dial readings is the amount of runout.
- ★ If axle runout exceeds the service limit, replace the axle.

Axle Runout/100 mm (3.94 in.)

Standard:	0.05 mm (0.002 in.) or less
Service Limit:	0.2 mm (0.08 in.)

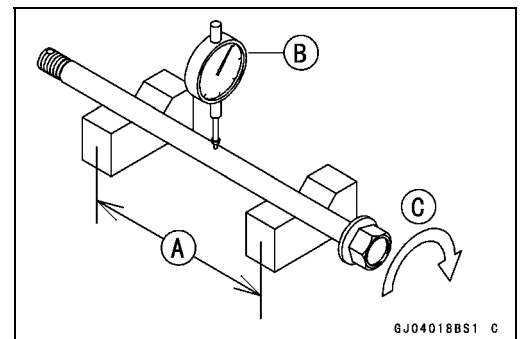

Balance Inspection

- Remove the wheel.
- Support the wheel so that it can be spun freely.
- Spin the wheel lightly, and mark [A] the wheel at the top when the wheel stops.
- Repeat this procedure several times. If the wheel stops of its own accord in various positions, it is well balanced.
- ★ If the wheel always stops in one position, adjust the wheel balance.

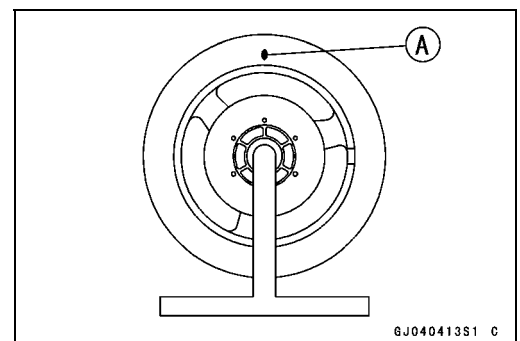

9-8 WHEELS/TIRES

Wheels (Rims)

Balance Adjustment

- If the wheel always stops in one position, provisionally attach a balance weight [A] on the rim at the marking using adhesive tape.
- Rotate the wheel 1/4 turn [B], and see whether or not the wheel stops in this position. If it does, the correct balance weight is being used.
- ★ If the wheel rotates and the weight goes up, replace the weight with the next heavier size. If the wheel rotates and the weight goes down, replace the weight with the next lighter size. Repeat these steps until the wheel remains at rest after being rotated 1/4 turn.
- Rotate the wheel another 1/4 turn and then another 1/4 turn to see if the wheel is correctly balanced.
- Repeat the entire procedure as many times as necessary to achieve correct wheel balance.
- Permanently install the balance weight.

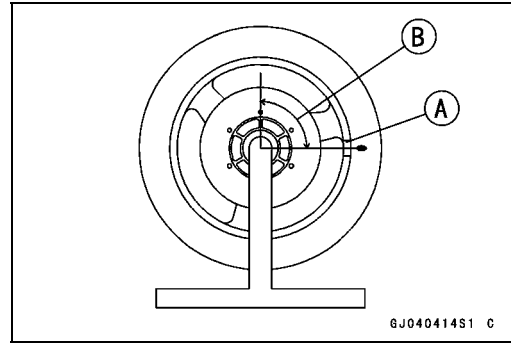

Balance Weight Removal

When the tire is not on the rim.

- Push [A] the blade portion toward the outside with a regular tip screw driver, and slip the weight off the rim flange.
- Discard the used balance weight.

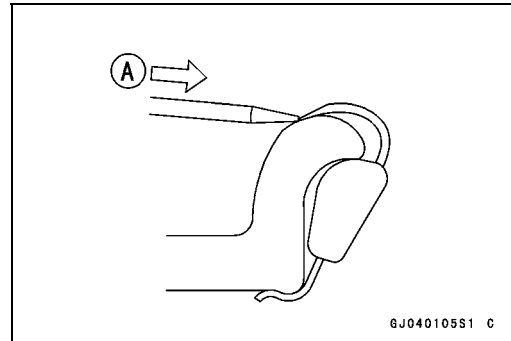

When the tire is on the rim.

- Pry [A] the balance weight off the rim flange using a regular tip screw driver as shown in the figure.
- Insert a tip of the screw driver between the tire bead [B] and weight blade [C] until the end of the tip reaches the end of the weight blade.
- Push the driver grip toward the tire so that the balance weight slips off the rim flange.
- Discard the used balance weight.

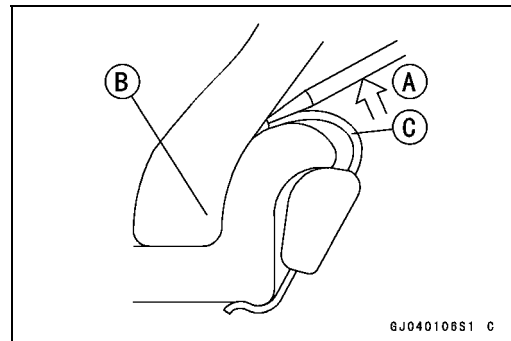

Balance Weight Installation

- Check if the weight portion has any play on the blade and clip.
- ★ If it does, discard it.

⚠ WARNING

If the balance weight has any play on the rim flange, the blade and/or clip have been stretched. Replace the loose balance weight. Do not reuse used balance weight. Unbalanced wheels can create an unsafe riding condition.

Wheels (Rims)

- Lubricate the balance weight blade, tire bead, and rim flange with a soap and water solution or rubber lubricant. This helps the balance weight slip onto the rim flange.

CAUTION

Never lubricate with engine oil or petroleum distillates because they will deteriorate the tire.

- When required total weight exceeds 20 g, install balance weight at both sides of rim flange as shown.

Required Total Weight	Weight Selection	
	One Side [A]	Other Side [B]
20 g	10 g	10 g
30 g	20 g	10 g
40 g	20 g	20 g
50 g	30 g	20 g
60 g	30 g	30 g
70 g	20 g + 20 g	30 g
80 g	20 g + 20 g	20 g + 20 g
90 g	20 g + 30 g	20 g + 20 g

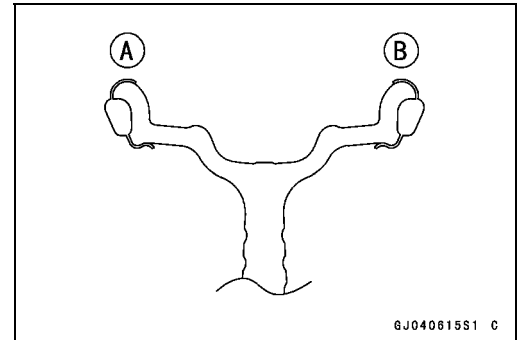

Balance Weight

Part Number	Weight (grams)
41075-1014	10 (0.35 oz)
41075-1015	20 (0.70 oz)
41075-1016	30 (1.05 oz)

NOTE

- Balance weights are available from Kawasaki dealers in 10, 20, and 30 gram sizes. An imbalance of less than 10 grams will not usually affect running stability.
- Do not use four or more balance weight (more than 90 gram). If the wheel requires an excess balance weight, disassemble the wheel to find the cause.

- Install the balance weight on the rim.
 - Slip the weight on the rim flange by pushing or lightly hammering the weight in the direction shown in the figure.
 - Push or Hammer [A]
 - Rim Flange [B]
 - Tire Bead [C]
 - Blade [D]

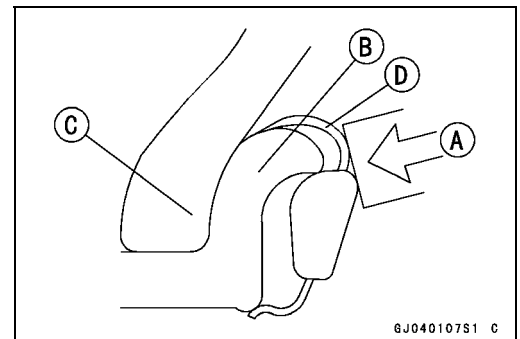

9-10 WHEELS/TIRES

Wheels (Rims)

○ Check that the blade [A] and weight [B] seat fully on the rim flange [C], and that the clip [D] is hooked over the rim ridge [E] and reaches rim flat portion.

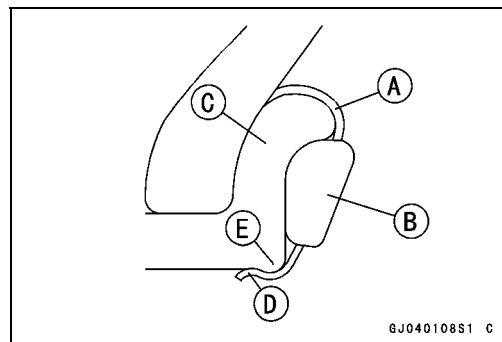

Tires

Air Pressure Inspection/Adjustment

- Measure the tire air pressure with an air pressure gauge [A] when the tires are cold (that is, when the motorcycle has not been ridden more than a mile during the past 3 hours).
- ★ Adjust the tire air pressure according to the specifications if necessary.

Air Pressure (when cold)

Front	Up to 182 kg (401 lb)	250 kPa (2.5 kgf/cm ² , 36 psi)
Rear	Up to 182 kg (401 lb)	290 kPa (2.9 kgf/cm ² , 41 psi)

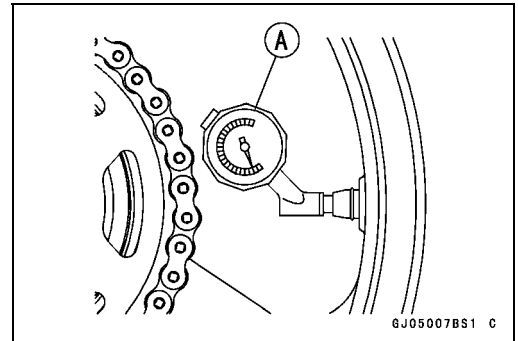

Tire Inspection

As the tire tread wears down, the tire becomes more susceptible to puncture and failure. An accepted estimate is that 90% of all tire failures occur during the last 10% of tread life (90% worn). So it is false economy and unsafe to use the tires until they are bald.

- Visually inspect the tire for cracks [A] and cuts [B], replacing the tire in case of damage. Swelling or high spots indicate internal damage, requiring tire replacement.
- Remove any imbedded stones [D], nail [C] or other foreign particles from the tread.

Wear Indicator [E]

- Measure the tread depth at the center of the tread with a depth gauge [A]. Since the tire may wear unevenly, take measurement at several places.
- ★ If any measurement is less than the service limit, replace the tire.

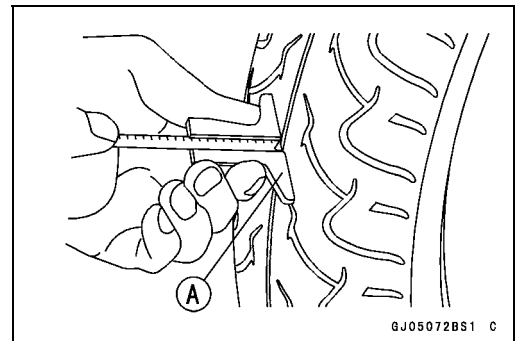
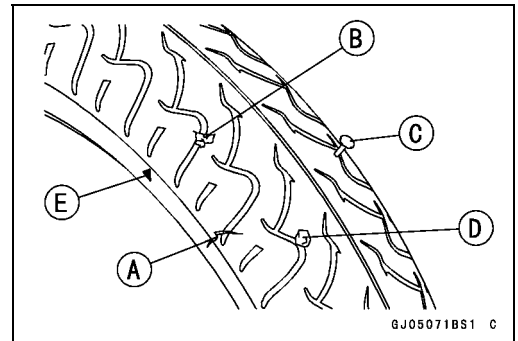

Tread Depth

Standard:

- Front 4.0 mm (0.16 in.) (DUNLOP),
 3.8 mm (0.15 in.) (MICHELIN)
- Rear 5.4 mm (0.21 in.) (DUNLOP)
 5.6 mm (0.22 in.) (MICHELIN)

Service Limit:

- Front 1 mm (0.04 in.), (DE) 1.6 mm (0.06 in.)
- Rear 2 mm (0.08 in.) (Up to 130 km/h (80 mph))
 3 mm (0.12 in.) (Over 130 km/h (80 mph))

⚠ WARNING

To ensure safe handling and stability, use only the recommended standard tires for replacement, inflated to the standard pressure.

9-12 WHEELS/TIRES

Tires

NOTE

- *Most countries may have their own regulations a minimum tire tread depth: be sure to follow them.*
- *Check and balance the wheel when a tire is replaced with a new one.*

Tire Removal

- Remove:
 - Wheel (see Front, Rear Wheels Removal)
 - Disc(s)
 - Valve Core (let out the air)
- To maintain wheel balance, mark the air valve position on the tire with chalk so that the tire can be reinstalled in the same position.
 - Chalk Mark or Yellow Mark [A]
 - Air Valve [B]
 - Align [C]
- Lubricate the tire beads and rim flanges on both sides with a soap and water solution or rubber lubricant. This helps the tire beads slip off the rim flanges.

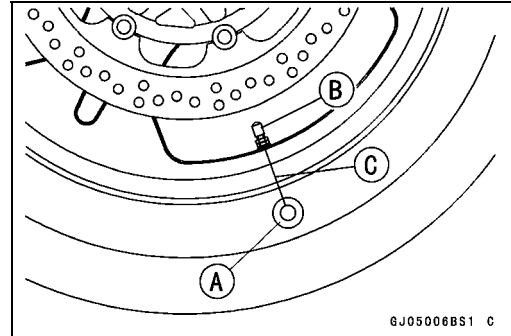

CAUTION

Never lubricate with engine oil or petroleum distillates because they will deteriorate the tire.

- Remove the tire from the rim using a suitable commercially available tire changer.

NOTE

- *The tires cannot be removed with hand tools because they fit the rims too tightly.*

Tire Installation

⚠ WARNING

Use the same manufacturer's on both front and rear wheels.

- Inspect the rim and tire, and replace them if necessary.
- Clean the sealing surfaces of the rim and tire, and smooth the sealing surfaces of the rim with a fine emery cloth if necessary.
- Remove the air valve and discard it.

CAUTION

Replace the air valve whenever the tire is replaced. Do not reuse the air valve.

Tires

- Install a new valve in the rim.
- Remove the valve cap, lubricate the stem seal [A] with a soap and water solution or rubber lubricant, and pull [B] the air valve [A] through the rim from the inside out until it snaps into place.

CAUTION

Do not use engine oil or petroleum distillates to lubricate the stem because they will deteriorate the rubber.

- The air valve is shown in the figure.

- [A] Valve Cap
- [B] Valve Core
- [C] Stem Seal
- [D] Valve Stem
- [E] Valve Seat
- [F] Valve Opened

- Apply a soap and water solution, or rubber lubricant to the rim flange and tire beads.
- Check the tire rotation mark on the front and rear tires and install them on the rim accordingly.
Tire Rotation Mark [A]
Rotating Direction [B]

- Position the tire on the rim so that the air valve [A] is at the tire balance mark [B] (the chalk mark made during removal, or the yellow paint mark on a new tire).
- Install the tire bead over the rim flange using a suitable commercially available tire changer.
- Lubricate the tire beads and rim flanges with a soap and water solution or rubber lubricant to help seat the tire beads in the sealing surfaces of the rim while inflating the tire.
- Center the rim in the tire beads, and inflate the tire with compressed air until the tire beads seat in the sealing surfaces.

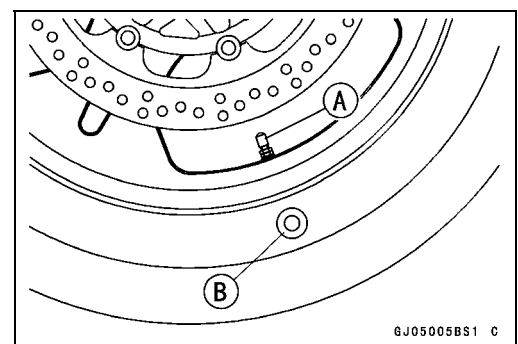
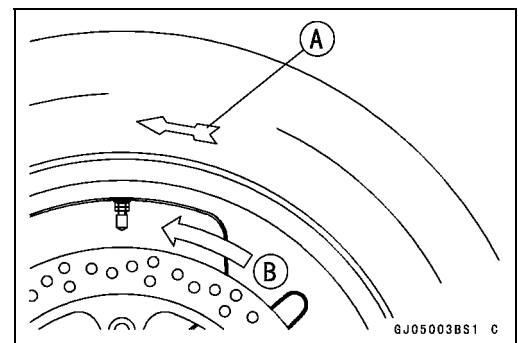
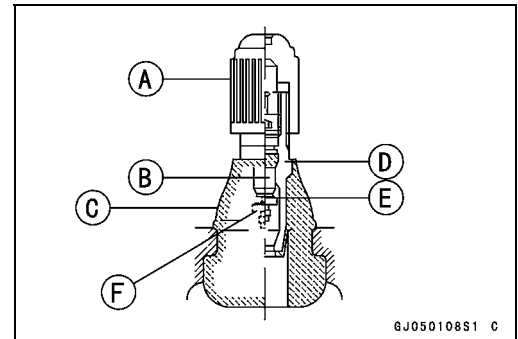
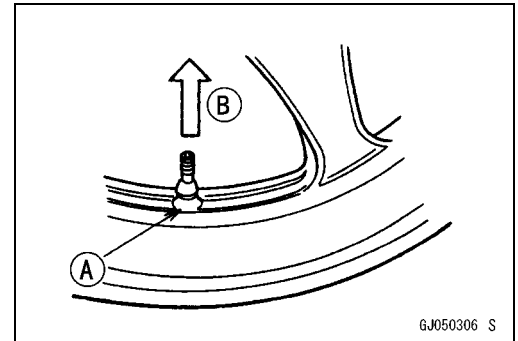

⚠ WARNING

Be sure to install the valve core whenever inflating the tire, and do not inflate the tire to more than 400 kPa (4.0 kg/cm², 57 psi). Overinflation can explode the tire with possibility of injury and loss of life.

9-14 WHEELS/TIRES

Tires

- Check to see that the rim lines [A] on both sides of the tire sidewalls are parallel with the rim flanges.
- ★ If the rim flanges and tire sidewall rim lines are not parallel, remove the valve core.
- Lubricate the rim flanges and tire beads.
- Install the valve core and inflate the tire again.
- After the tire beads seat in the rim flanges, check for air leakage.
- Inflate the tire slightly above standard inflation.
- Use a soap and water solution or submerge the tire, and check for bubbles that would indicate leakage.
- Adjust the air pressure to the specified pressure (see Tire Inspection).
- Install the brake disc(s) so that the marked side faces out (see Brakes chapter).
- Adjust the wheel balance.

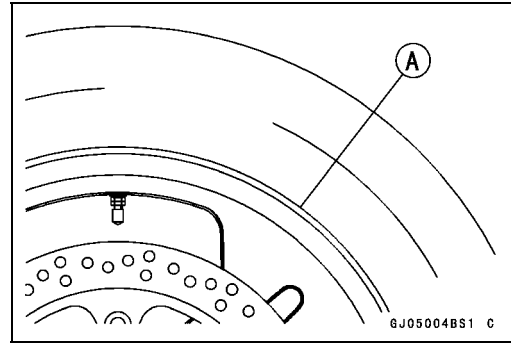

Tire Repair

Currently two types of repair for tubeless tires have come into wide use. One type is called a temporary (external) repair which can be carried out without removing the tire from the rim, and the other type is called permanent (internal) repair which requires tire removal. It is generally understood that higher running durability is obtained by permanent (internal) repairs than by temporary (external) ones. Also, permanent (internal) repairs have the advantage of permitting a thorough examination for secondary damage not visible from external inspection of the tire. For these reasons, Kawasaki does not recommend temporary (external) repair. Only appropriate permanent (internal) repairs are recommended. Repair methods may vary slightly from make to make. Follow the repair methods indicated by the manufacturer of the repair tools and materials so that safe results can be obtained.

Hub Bearing

Hub Bearing Removal

- Remove the wheel, and take out the following.
 - Collars
 - Coupling (out of rear hub)
 - Grease Seals
 - Circlips [A]

Special Tool - Inside Circlip Pliers: 57001-143 [B]

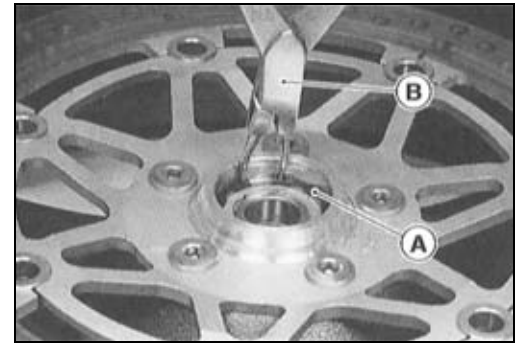

- Use the bearing remover to remove the hub bearing [A].

CAUTION

Do not lay the wheel on the ground with the disc facing down. This can damage or warp the disc. Place blocks under the wheel so that the disc does not touch the ground.

Special Tools - Bearing Remover Shaft, $\phi 13$: 57001-1377 [B]

Bearing Remover Head, $\phi 25 \times \phi 28$: 57001-1346 [C]

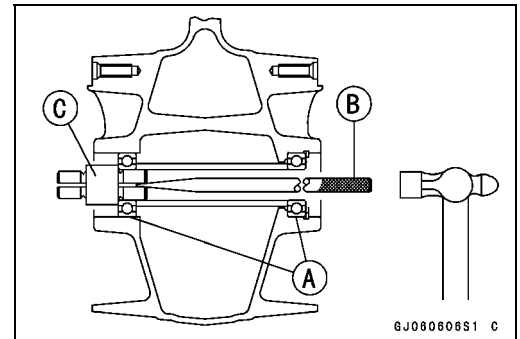

Hub Bearing Installation

- Before installing the wheel bearings, blow any dirt or foreign particles out of the hub with compressed air to prevent contamination of the bearings.
- Replace the bearings with new ones.

NOTE

○ Install the bearings so that the marked side faces out.

- Install the bearings by using the bearing driver set which does not contact the bearing inner race.
- Press in each right the bearing [A] until they are bottomed.

Special Tool - Bearing Driver Set: 57001-1129 [B]

- Replace the circlips with new ones.

Special Tool - Inside Circlip Pliers: 57001-143

- Replace the grease seals with new ones.
- Press in the grease seals [A] so that the seal surface is flush [B] with the end of the hole.
- Apply high temperature grease to the grease seal lips.

Special Tool - Bearing Driver Set: 57001-1129 [C]

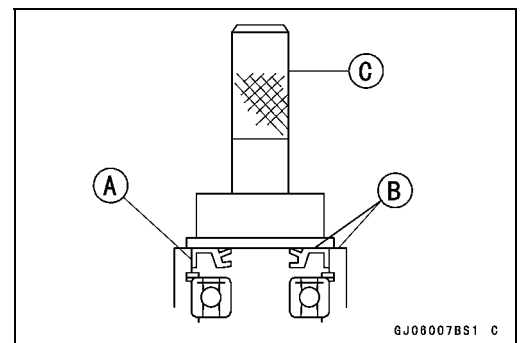
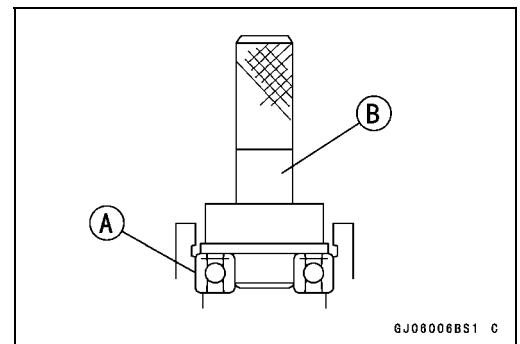

9-16 WHEELS/TIRES

Hub Bearing

Hub Bearing Inspection

Since the hub bearings are made to extremely close tolerances, the clearance can not normally be measured.

NOTE

○Do not remove any bearings for inspection. If any bearings are removed, they will need to be replaced with new ones.

- Turn each bearing in the hub back and forth [A] while checking for plays, roughness, or binding.
- ★ If bearing play, roughness, or binding is found, replace the bearing.
- Examine the bearing seal [B] for tears or leakage.
- ★ If the seal is torn or is leaking, replace the bearing.

Hub Bearing Lubrication

NOTE

○Since the hub bearings are packed with grease and sealed, lubrication is not required.

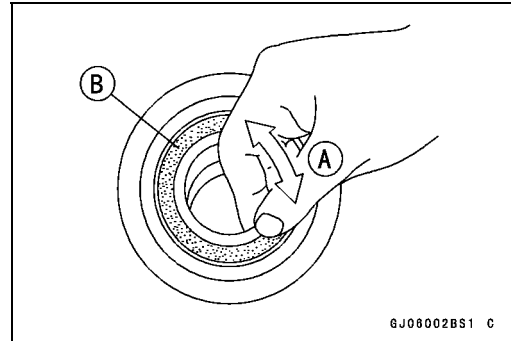

Final Drive

Table of Contents

Exploded View	10-2
Specifications	10-3
Drive Chain.....	10-4
Drive Chain Slack Inspection.....	10-4
Drive Chain Slack Adjustment	10-4
Wheel Alignment Inspection/Adjustment	10-4
Drive Chain Wear Inspection	10-5
Drive Chain Lubrication.....	10-5
Drive Chain Removal.....	10-6
Drive Chain Installation.....	10-6
Drive Chain Replacement (ZX600-J4 ~ (US), ZX600J6F ~ (CA)).....	10-7
Sprocket, Coupling	10-10
Engine Sprocket Removal	10-10
Engine Sprocket Installation	10-10
Rear Sprocket Removal.....	10-11
Rear Sprocket Installation.....	10-11
Coupling Installation.....	10-11
Coupling Bearing Removal	10-11
Coupling Bearing Installation	10-12
Coupling Bearing Inspection.....	10-12
Coupling Bearing Lubrication.....	10-12
Coupling Damper Inspection.....	10-12
Sprocket Wear Inspection.....	10-13
Rear Sprocket Warp Inspection	10-13

10-2 FINAL DRIVE

Exploded View

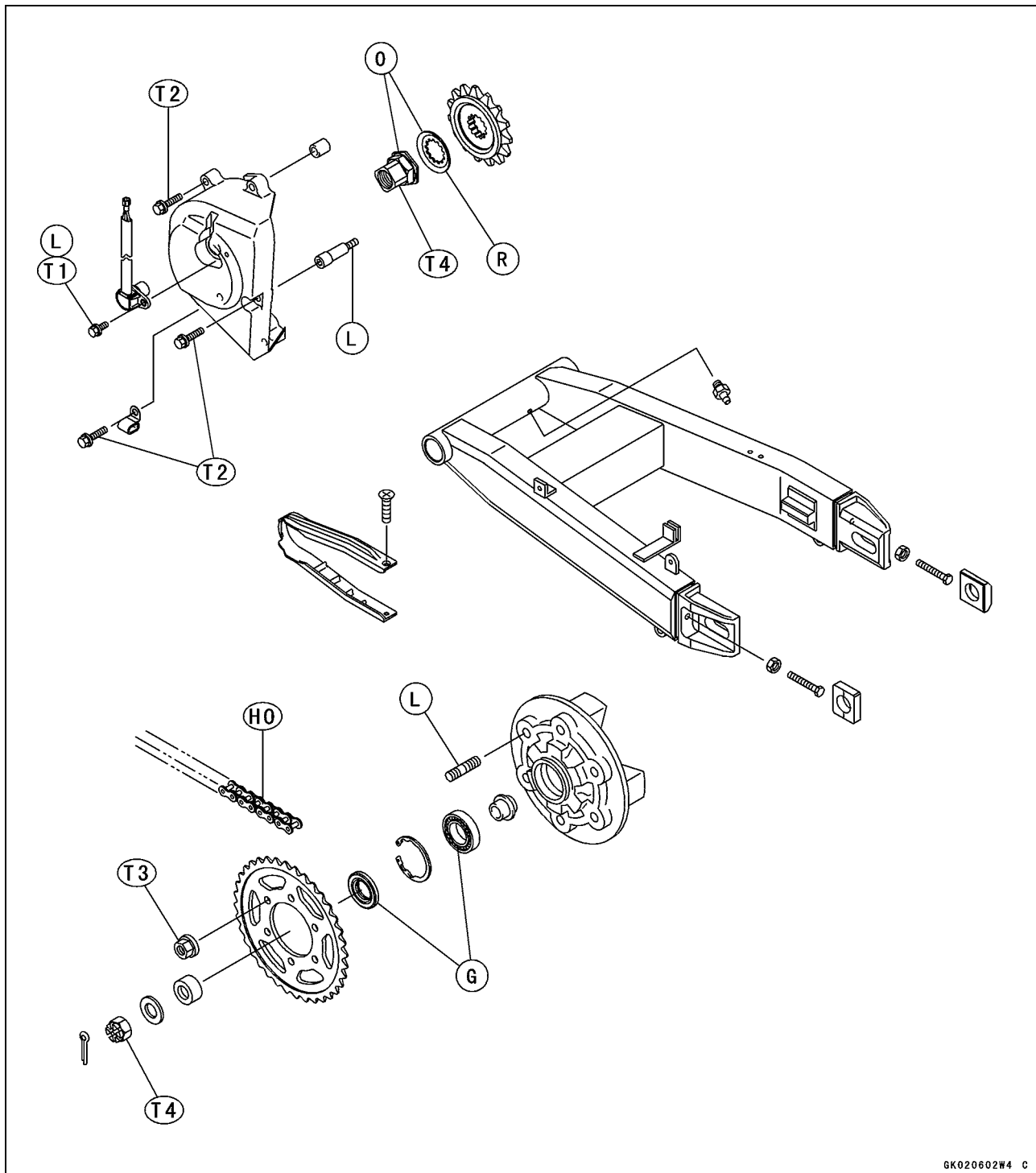

T1: 6.9 N·m (0.7 kgf·m, 61 in·lb)

T2: 12 N·m (1.2 kgf·m, 104 in·lb)

T3: 59 N·m (6.0 kgf·m, 43 ft·lb)

T4: 127 N·m (13.0 kgf·m, 94 ft·lb)

G: Apply grease.

HO: Apply heavy oil.

L: Apply a non-permanent locking agent.

O: Apply oil.

R: Replacement Parts

Specifications

Item	Standard	Service Limit
Drive Chain		
Chain Slack	30 ~ 35 mm (1.18 ~ 1.38 in.)	
20-Link Length	317.5 ~ 318.2 mm (12.50 ~ 12.53 in.)	323 mm (12.72 in.)
Standard Chain:		
Make	ENUMA	---
Type	EK525MVXL, Endless (ZX600-J1 ~ J3)	---
	EK525UVXL2, Endless (ZX600-J4 ~) (US)	
	EK525UVXL2, Endless (ZX600-J6F ~) (CA)	
Link	108 links	---
Sprockets		
Rear Sprocket Warp	0.4 mm (0.016 in.) or less	0.5 mm (0.020 in.)

US: United States Model

CA: Canada Model

Special Tools - Inside Circlip Pliers: 57001-143

Bearing Driver Set: 57001-1129

Jack: 57001-1238

10-4 FINAL DRIVE

Drive Chain

Drive Chain Slack Inspection

NOTE

- Check the slack with the motorcycle setting on its side stand.
- Clean the chain if it is dirty, and lubricate it if it appears dry.
- Check the wheel alignment (see Wheel Alignment Inspection).
- Rotate the rear wheel to find the position where the chain is tightest.
- Measure the vertical movement (chain slack) [A] midway between the sprockets.
- ★ If the chain slack exceeds the standard, adjust it.

Chain Slack

Standard: 30 ~ 35 mm (1.18 ~ 1.38 in.)

Drive Chain Slack Adjustment

- Remove the cotter pin [A], and loosen the axle nut [B].
- Loosen the both chain adjuster locknuts [C].
- ★ If the chain is too loose, turn out the left and right chain adjuster [D] evenly.
- ★ If the chain is too tight, turn in the left and right chain adjusters evenly, and kick the wheel forward.
- Turn both chain adjusters evenly until the drive chain has the correct amount of slack. To keep the chain and wheel properly aligned, the notch [E] on the left wheel alignment indicator [F] should align with the same swingarm mark or position [G] that the right indicator notch aligns with.

⚠ WARNING

Misalignment of the wheel will result in abnormal wear and may result in an unsafe riding condition.

- Tighten both chain adjuster locknuts securely.
- Tighten the axle nut.

Torque - Rear Axle Nut: 108 N·m (11 kgf·m, 80 ft·lb)

- Turn the wheel, measure the chain slack again at the tightest position, and readjust if necessary.
- Insert a new cotter pin and spread its ends.

Wheel Alignment Inspection/Adjustment

- Check that the notch [A] on the left alignment indicator [B] aligns with the same swingarm mark or position [C] that the right alignment indicator notch aligns with.
- ★ If they do not, adjust the chain slack and align the wheel alignment (see Slack Adjustment).

NOTE

- Wheel alignment can be also checked using the straightedge or string method.

⚠ WARNING

Misalignment of the wheel will result in abnormal wear, and may result in an unsafe riding condition.

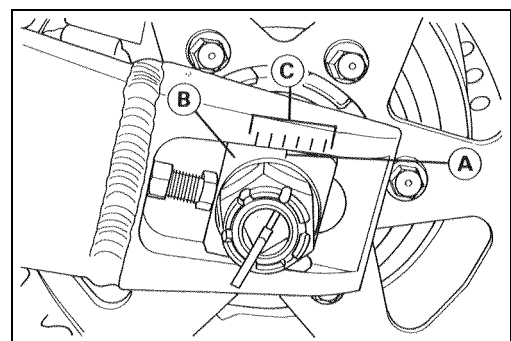
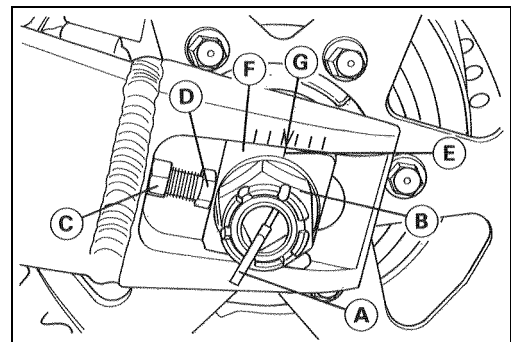
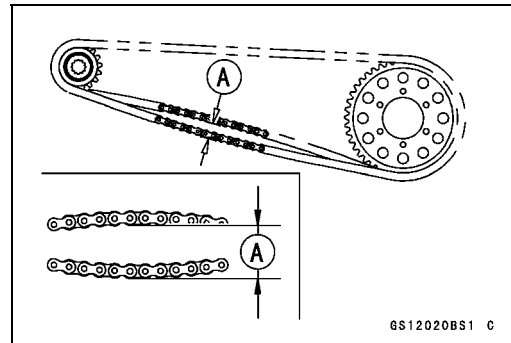

Drive Chain

Drive Chain Wear Inspection

- Remove:
 - Chain Cover
- Rotate the rear wheel to inspect the drive chain for damaged rollers, and loose pins and links.
- ★ If there is any irregularity, replace the drive chain.
- ★ Lubricate the drive chain if it appears dry.
- Stretch the chain taut by hanging a 98 N (10 kg, 20 lb) weight [A] on the chain.
- Measure the length of 20 links [B] on the straight part [C] of the chain from the pin center of the 1st pin to the pin center of the 21st pin. Since the chain may wear unevenly, take measurements at several places.
- ★ If any measurements exceed the service limit, replace the chain. Also, replace the front and rear sprockets when the drive chain is replaced.

Drive Chain 20-link Length

Standard: 317.5 ~ 318.2 mm (12.50 ~ 12.53 in.)

Service Limit: 323 mm (12.72 in.)

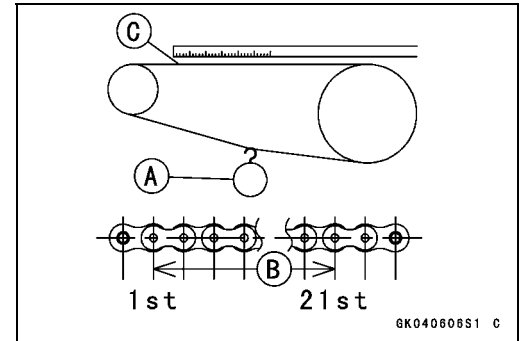

⚠ WARNING

If the drive chain wear exceeds the service limit, replace the chain or an unsafe riding condition may result. A chain that breaks or jumps off the sprockets could snag on the engine sprocket or lock the rear wheel, severely damaging the motorcycle and causing it to go out of control. For safety, use only the standard chain.

Standard Chain

Make: ENUMA

Type: EX525MVXL, Endless (ZX600-J1 ~ J3)

EX525UVXL2 (ZX600-J4 ~ (US), ZX600J6F ~ (CA))

Link: 108 Links

Drive Chain Lubrication

- If a special lubricant is not available, a heavy oil such as SAE 90 is preferred to a lighter oil because it will stay on the chain longer and provide better lubrication.
- If the chain appears especially dirty, clean it before lubrication.

CAUTION

The O-rings between the side plates seal in the lubricant between the pin and the bushing. To avoid damaging the O-rings and resultant loss of lubricant, observe the following rules.

Use only kerosene or diesel oil for cleaning an O-ring drive chain.

Any other cleaning solution such as gasoline or trichloroethylene will cause deterioration and swelling of the O-ring.

Immediately blow the chain dry with compressed air after cleaning.

Complete cleaning and drying the chain within 10 minutes.

10-6 FINAL DRIVE

Drive Chain

- Apply oil to the sides of the rollers so that oil will penetrate to the rollers and bushings. Apply the oil to the O-rings so that the O-rings will be coated with oil.
- Wipe off any excess oil.
 - Oil Applied Areas [A]
 - O-ring [B]

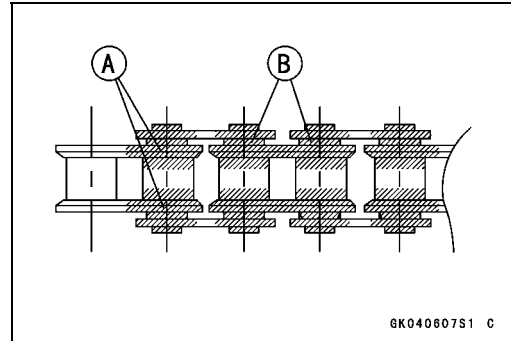

Drive Chain Removal

- Remove:
 - Chain Cover Screws [A]
 - Chain Cover [B]
 - Rear Wheel (see Wheels/Tires chapter)
 - Swingarm (see Suspension chapter)
 - Engine Sprocket Cover (see this chapter)
- Disengage the drive chain [A] from the engine sprocket [B], and take it off the chassis.

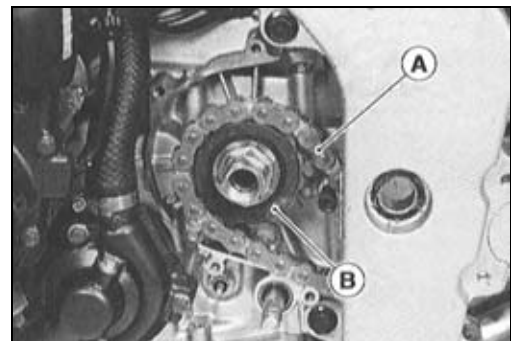
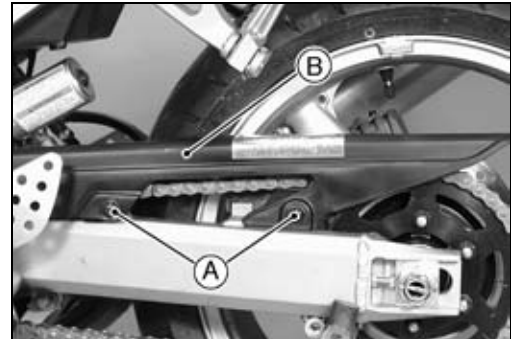

Drive Chain Installation

- Engage the drive chain to the engine sprocket.
- Install:
 - Swingarm (see Suspension chapter)
 - Rear Wheel (see Wheels/Tires chapter)
 - Engine Sprocket Cover
 - Chain Cover
- Fit the flap [A] into the slot [B] in the swingarm.
- Adjust the chain slack after installing the chain (see Slack Adjustment).

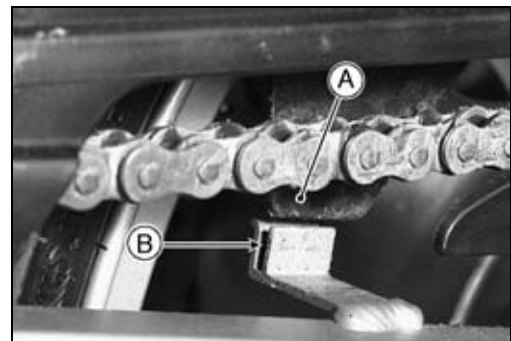

Drive Chain

Drive Chain Replacement (ZX600-J4 ~ (US),
ZX600J6F ~ (CA))

CAUTION

For safety, if the drive chain shall be replaced, re-
place it using a recommended tool.

Recommended Tool - Type: EK JOINT Tool #50
Brand: ENUMA CHAIN

Body [A]
Handlebar [B]
Cutting and Rivetting Pin [C]
For Cutting [D]
For Rivetting [E]
Plate Holder (A) [F]
Plate Holder (B) [G]
Gauge [H]

Drive Chain Specifications

Type: EX525UVXL2, Endless

Link: 108 Links (KLJ)

- Remove:
Chain Cover (see Drive Chain Removal)
Engine Sprocket Cover (see Engine Sprocket Removal)
- Grind [A] the pin head to make it flat.
- Set the cutting and rivetting pin [B] as shown.

- Screw the pin holder until it touches the link pin.
- Be sure that the cutting pin hits center of the link pin.

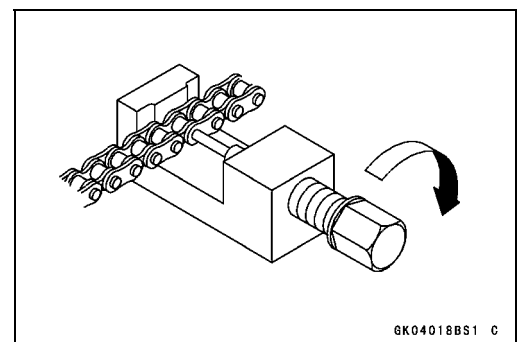
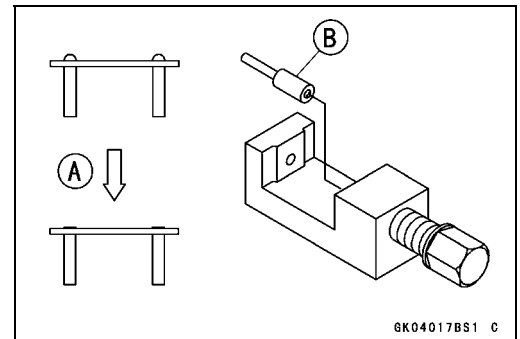
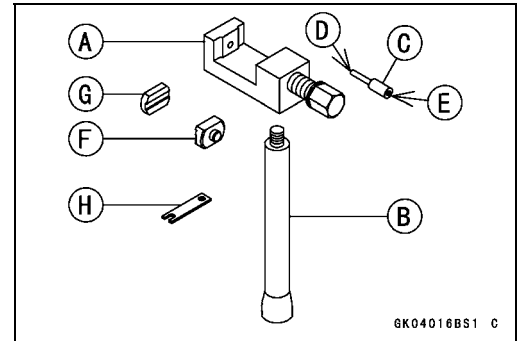

10-8 FINAL DRIVE

Drive Chain

- Screw the handlebar [A] into the body.
- Turn the pin holder with the wrench [B] clockwise to extract the link pin.

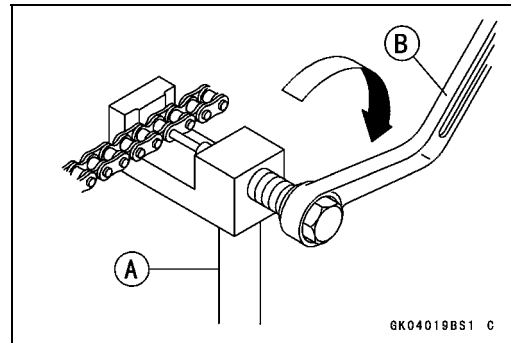

- Replace the link pin, link plate and grease seals.
- Apply grease to the link pins [A] and grease the seals [B] [C].
- Engage the drive chain on the engine and rear sprockets.
- Insert the link pins in the drive chain ends.
- Install the grease seals [C].
- Install the link plate [D] so that the mark faces out.
- Push the link plate by hand or plier to fix it.
- Be sure to set the grease seals correctly.

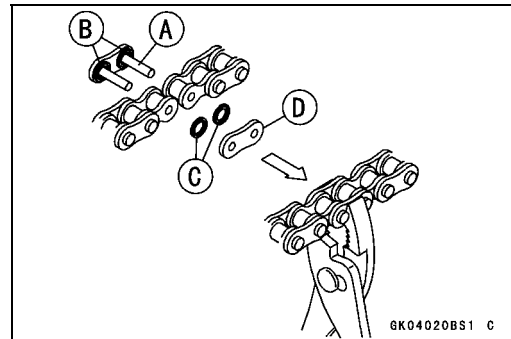

- Set the plate holder (A) [A] and plate holder (B) [B] on the body.

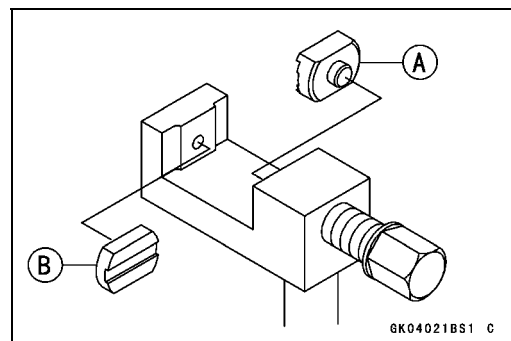

- Fit the plate holder (A) to the link plate.
- Turn the pin holder by hand until the plate holder (B) touches the other link plate.

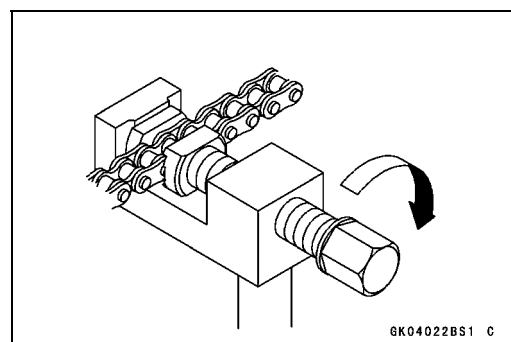

- Turn the pin holder by a wrench clockwise until two pins of link come into groove of the plate holder (A).
- Take off the plate holder.

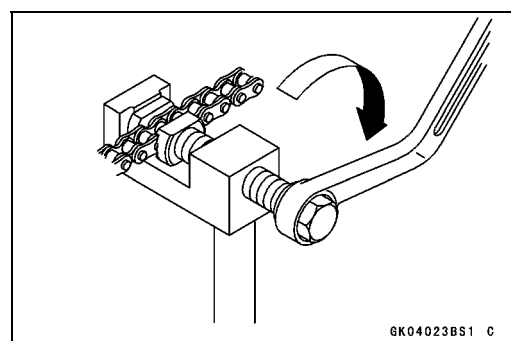

Drive Chain

- Set the plate holder (B) [A] and the cutting and rivetting pin [B] as shown.

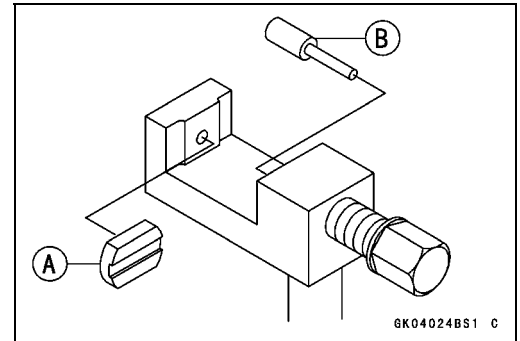

- Turn the pin holder until the rivetting pin touches the link pin.

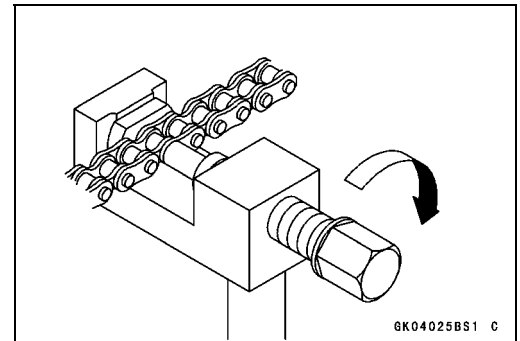

- Turn the wrench clockwise until the tip of rivetting pin contact with the link pin.
- Rivet it.
- Repeat the same procedure for the other link pin.

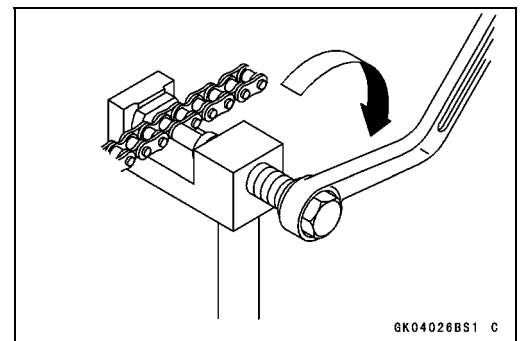

- After staking, check the staked area of the link pin for cracks.
- Measure the outside diameter [A] of the link pin and link plates width [B].

Link Pin Outside Diameter

Standard: 5.6 ~ 6.0 mm (0.22 ~ 0.24 in.)

Link Plates Outside Width

Standard: 19.85 ~ 20.00 mm (0.78 ~ 0.79 in.)

- ★ If the reading exceeds the specified length, cut and rejoin the chain again.

- Check:
 - Movement of the Rollers
- Adjust the drive chain slack after installing the chain.

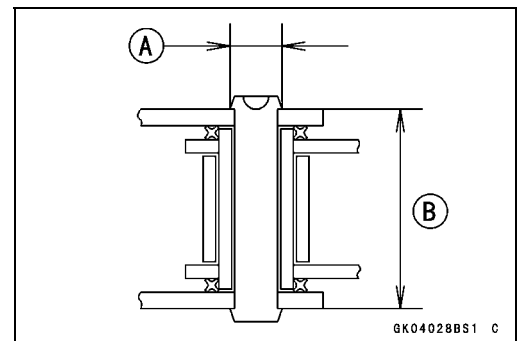

10-10 FINAL DRIVE

Sprocket, Coupling

Engine Sprocket Removal

- Remove:
 - Speed Sensor Bolt [A]
 - Speed Sensor [B]
 - Engine Sprocket Cover Bolts [C]
 - Engine Sprocket Cover [D]

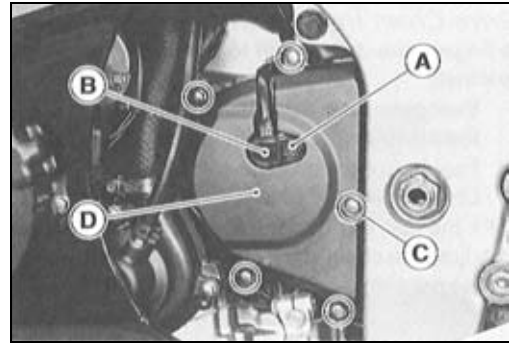

- Flatten out the bended washer [A].
- Remove the engine sprocket nut [B] and washer.

NOTE

○When loosening the engine sprocket nut, hold the rear brake on.

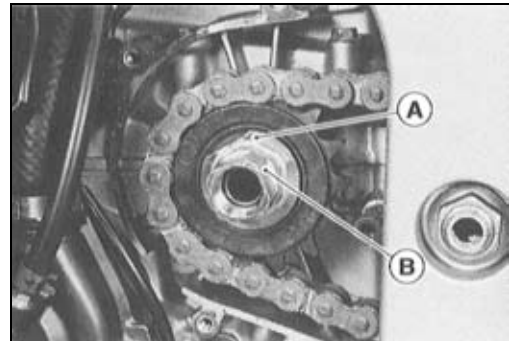

- Using the jack, raise the rear wheel off the ground.
Special Tool - Jack: 57001-1238
- Loosen the drive chain (see Slack Adjustment).
- Remove the drive chain from the rear sprocket toward the right.
- Disengage the drive chain [A] from the engine sprocket [B].
- Pull the engine sprocket off the output shaft [C].

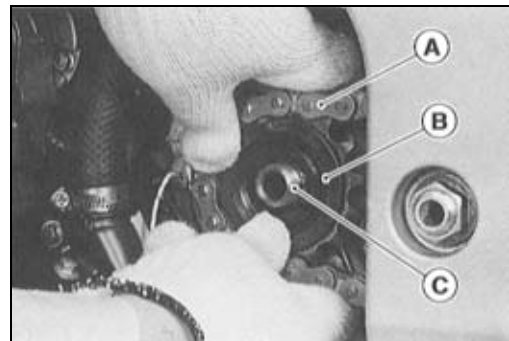

Engine Sprocket Installation

- Replace the sprocket washer and axle cotter pin.
- Install the engine sprocket onto the shaft so that the mark side [A] faces outwards.
- Apply oil to the threads of the output shaft and the seating surface of the engine sprocket nut.
- After torquing the engine sprocket nut, bend the one side of the washer over the nut.

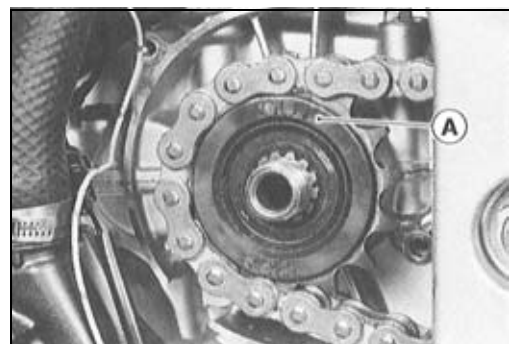

NOTE

○Tighten the nut while applying the rear brake.

Torque - Engine Sprocket Nut: 127 N·m (13 kgf·m, 94 ft·lb)

- Adjust the drive chain slack after installing the sprocket (see Slack Adjustment).
- Install the engine sprocket cover, and tighten the bolts.

Torque - Engine Sprocket Cover Bolts: 12 N·m (1.2 kgf·m, 104 in·lb)

- Apply a non-permanent locking agent to the threads of the speed sensor bolt, and tighten it.

Torque - Speed Sensor Bolt: 6.9 N·m (0.70 kgf·m, 61 in·lb)

Sprocket, Coupling

Rear Sprocket Removal

- Remove the rear wheel (see Wheels/Tires chapter).

CAUTION

Do not lay the wheel on the ground with the disc facing down. This can damage or warp the disc. Place blocks under the wheel so that the disc does not touch the ground.

- Remove the rear sprocket nuts [A].
- Remove the rear sprocket [B].

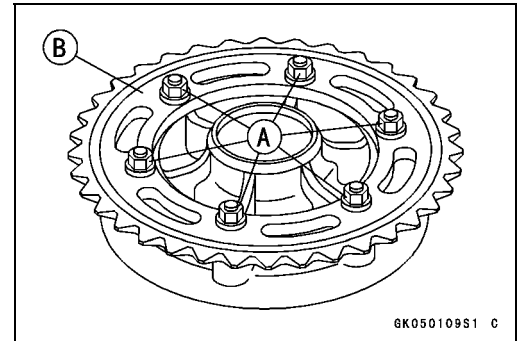

Rear Sprocket Installation

- Install the sprocket facing the tooth number marking [A] outward.
 - Tighten the rear sprocket nuts.
- Torque - Rear Sprocket Nut: 59 N·m (6.0 kgf·m, 43 ft·lb)**
- Install the rear wheel (see Wheels/ Tires chapter).

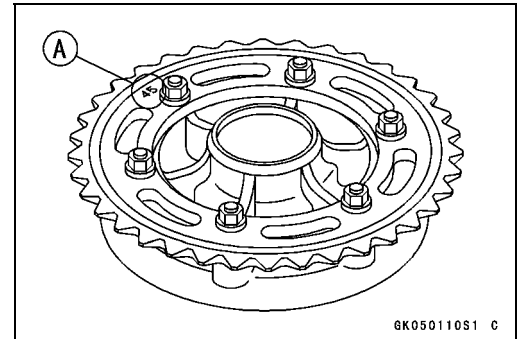

Coupling Installation

- Grease the following and install the coupling.
 - Coupling Grease Seal [A]
 - Coupling Internal Surface [B]

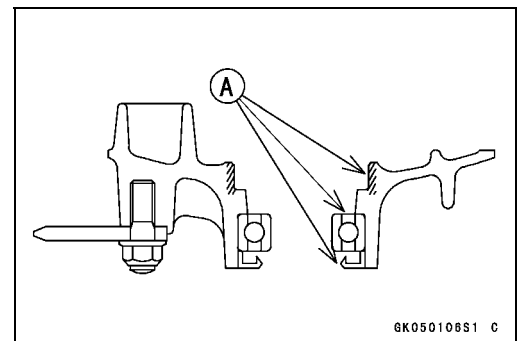

Coupling Bearing Removal

- Remove:
 - Coupling
 - Grease Seal
 - Circlip [A]
- Special Tool - Inside Circlip Pliers: 57001-143 [B]**

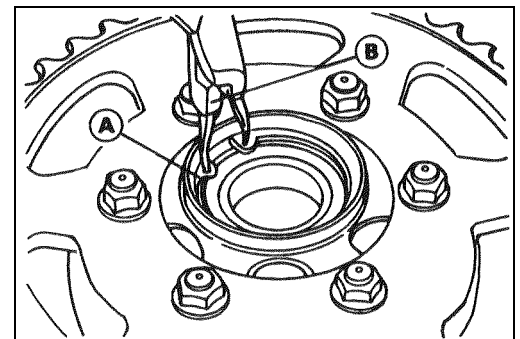

- Remove the bearing [A] by tapping from the wheel side.
- Special Tool - Bearing Driver Set: 57001-1129 [B]**

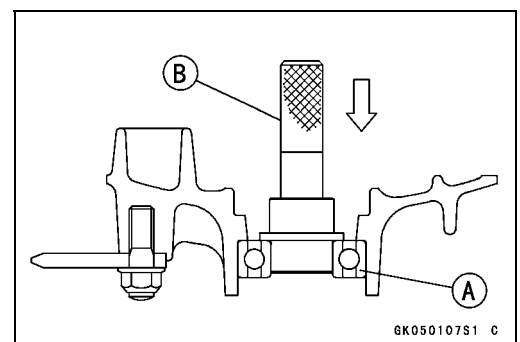

10-12 FINAL DRIVE

Sprocket, Coupling

Coupling Bearing Installation

- Replace the bearing with a new one.
- Press in the bearing [A] until it is bottomed.
Special Tool - Bearing Driver Set: 57001-1129 [B]
- Pack the bearing with high temperature grease.
- Replace the circlip with a new one.
Special Tool - Inside Circlip Pliers: 57001-143

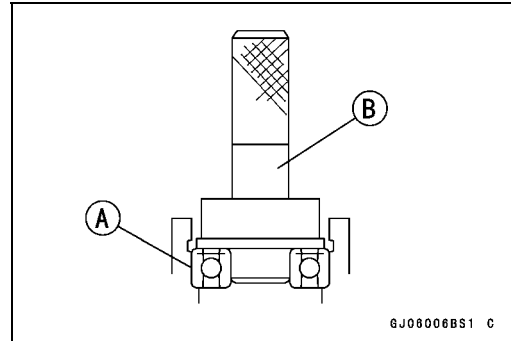

- Replace the grease seal with a new one.
- Press in the grease seal so that the seal surface is flush with the end of the hole.
- Apply high temperature grease to the grease seal lips.
Special Tool - Bearing Driver Set: 57001-1129

Coupling Bearing Inspection

Since the coupling bearing is made to extremely close tolerances, the clearance can not normally be measured.

NOTE

○ It is not necessary to remove the coupling bearing for inspection. If the bearing is removed, it will need to be replaced with a new one.

- Turn the bearing in the coupling back and forth [A] while checking for plays, roughness, or binding.
- ★ If bearing play, roughness, or binding is found, replace the bearing.
- Examine the bearing seal [B] for tears or leakage.
- ★ If the seal is torn or is leaking, replace the bearing.

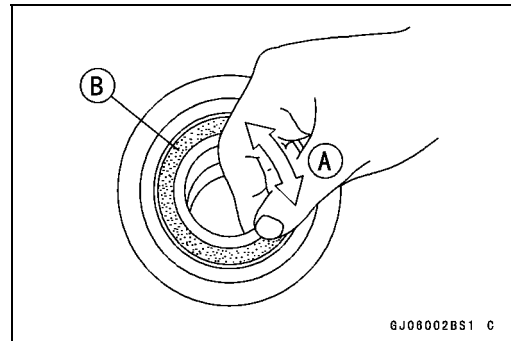

Coupling Bearing Lubrication

- Pack the bearing with good quality bearing grease. Turn the bearing around by hand a few times to make sure the grease is distributed uniformly inside the bearing.

Coupling Damper Inspection

- Remove the rear wheel coupling, and inspect the rubber dampers [A].
- Replace the damper if it appears damaged or deteriorated.

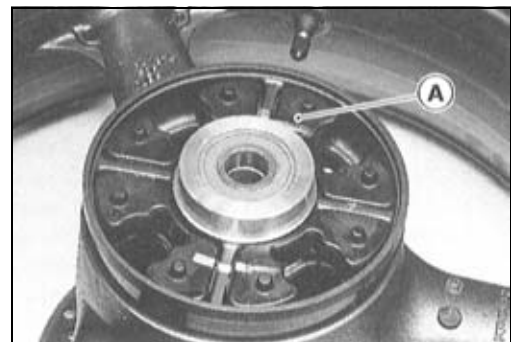

Sprocket, Coupling

Sprocket Wear Inspection

- Visually inspect the engine and rear sprocket teeth for wear and damage.
- ★ If the teeth are worn as illustrated, replace the sprocket, and inspect the drive chain wear (see Drive Chain Wear Inspection).
 - [A] Worn Tooth (Engine Sprocket)
 - [B] Worn Tooth (Rear Sprocket)
 - [C] Direction of Rotation

NOTE

- If a sprocket requires replacement, the chain is probably worn also.
- When replacing a sprocket, inspect the chain.

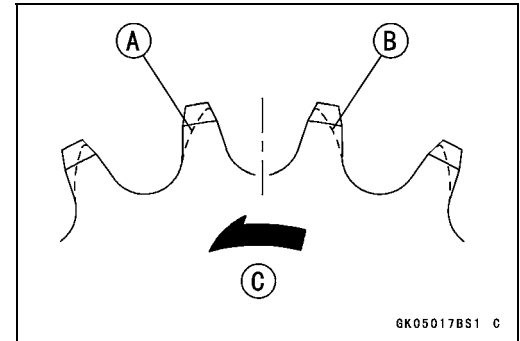

Rear Sprocket Warp Inspection

- Raise the rear wheel off the ground (see Wheels/Tires chapter) so that it will turn freely.
- Set a dial gauge [A] against the rear sprocket [B] near the teeth as shown, and rotate [C] the rear wheel to measure the sprocket runout (warp). The difference between the highest and lowest dial gauge readings is the amount of runout (warp).
- ★ If the runout exceeds the service limit, replace the rear sprocket.

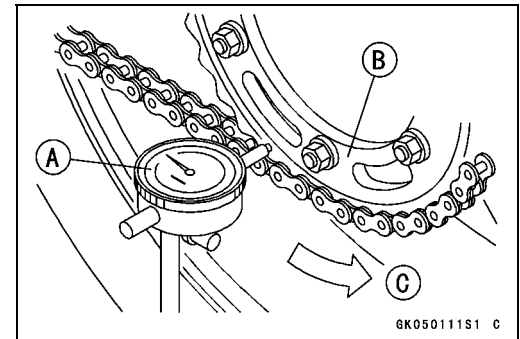

Rear Sprocket Warp

- Standard:** 0.4 mm (0.016 in.) or less
- Service Limit:** 0.5 mm (0.020 in.)

Brakes

Table of Contents

Exploded View	11-2	Rear Brake Pad Installation	11-12
Specifications	11-4	Brake Pad Wear Inspection	11-12
Brake Pedal	11-5	Master Cylinder	11-13
Brake Lever Position Adjustment.	11-5	Front Master Cylinder Removal ...	11-13
Brake Pedal Position Inspection .	11-5	Front Master Cylinder Installation	11-13
Brake Pedal Position Adjustment	11-5	Rear Master Cylinder Removal....	11-13
Calipers	11-6	Rear Master Cylinder Installation.	11-14
Front Caliper Removal	11-6	Front Master Cylinder	
Rear Caliper Removal.....	11-6	Disassembly.....	11-14
Caliper Installation	11-6	Rear Master Cylinder	
Front Caliper Disassembly.....	11-7	Disassembly.....	11-14
Front Caliper Assembly.....	11-8	Master Cylinder Assembly	11-15
Rear Caliper Disassembly	11-8	Master Cylinder Inspection (Visual	
Rear Caliper Assembly	11-9	Inspection).....	11-15
Caliper Fluid Seal Damage		Brake Disc	11-17
Inspection.....	11-10	Brake Disc Removal	11-17
Caliper Dust Seal/Rubber Boot		Brake Disc Installation	11-17
Damage Inspection	11-10	Brake Disc Wear Inspection.....	11-17
Caliper Piston and Cylinder		Brake Disc Warp Inspection.....	11-17
Damage Insepction	11-10	Brake Fluid	11-18
Caliper Holder Shaft Wear		Level Inspection	11-18
Inspection.....	11-10	Brake Fluid Change	11-18
Brake Pads.....	11-11	Bleeding the Brake Line.....	11-19
Front Brake Pad Removal.....	11-11	Brake Hose.....	11-22
Front Brake Pad Installation.....	11-11	Brake Hose Removal/Installation.	11-22
Rear Brake Pad Removal	11-11	Brake Hose Inspection.....	11-22

11-2 BRAKES

Exploded View

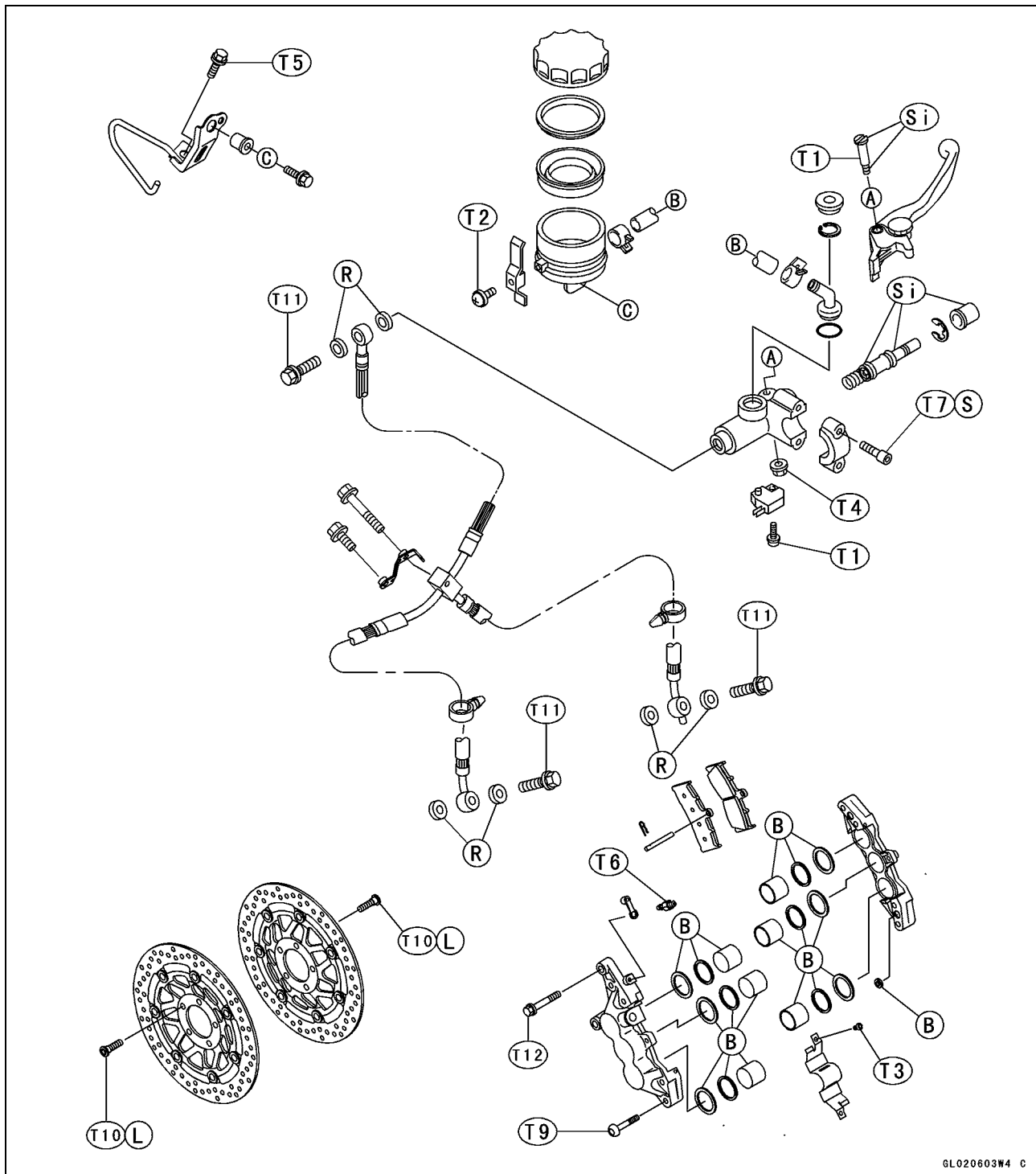

GL020603W4 C

- 1. Brake Rod Joint Cotter Pin
- 2. Brake Pedal Bolt
- T1: 1.0 N·m (0.10 kgf·m, 9 in·lb)
- T2: 1.5 N·m (0.15 kgf·m, 13 in·lb)
- T3: 2.9 N·m (0.30 kgf·m, 26 in·lb)
- T4: 5.9 N·m (0.60 kgf·m, 52 in·lb)
- T5: 6.9 N·m (0.70 kgf·m, 61 in·lb)
- T6: 7.8 N·m (0.80 kgf·m, 69 in·lb)
- T7: 8.8 N·m (0.90 kgf·m, 78 in·lb) (ZX600J1 ~ J4, J6F)
- 11 N·m (1.1 kgf·m, 97 in·lb) (ZX600J7F)

- T8: 18 N·m (1.8 kgf·m, 13 ft·lb)
- T9: 21 N·m (2.1 kgf·m, 15 ft·lb)
- T10: 27 N·m (2.8 kgf·m, 20 ft·lb)
- T11: 25 N·m (2.5 kgf·m, 18 ft·lb)
- T12: 34 N·m (3.5 kgf·m, 25 ft·lb)
- B: Apply brake fluid.
- G: Apply grease.
- L: Apply a non-permanent locking agent.
- R: Replacement Parts
- S: Follow the specific tightening sequence.
- Si: Apply silicone grease (ex. PBC grease).

Exploded View

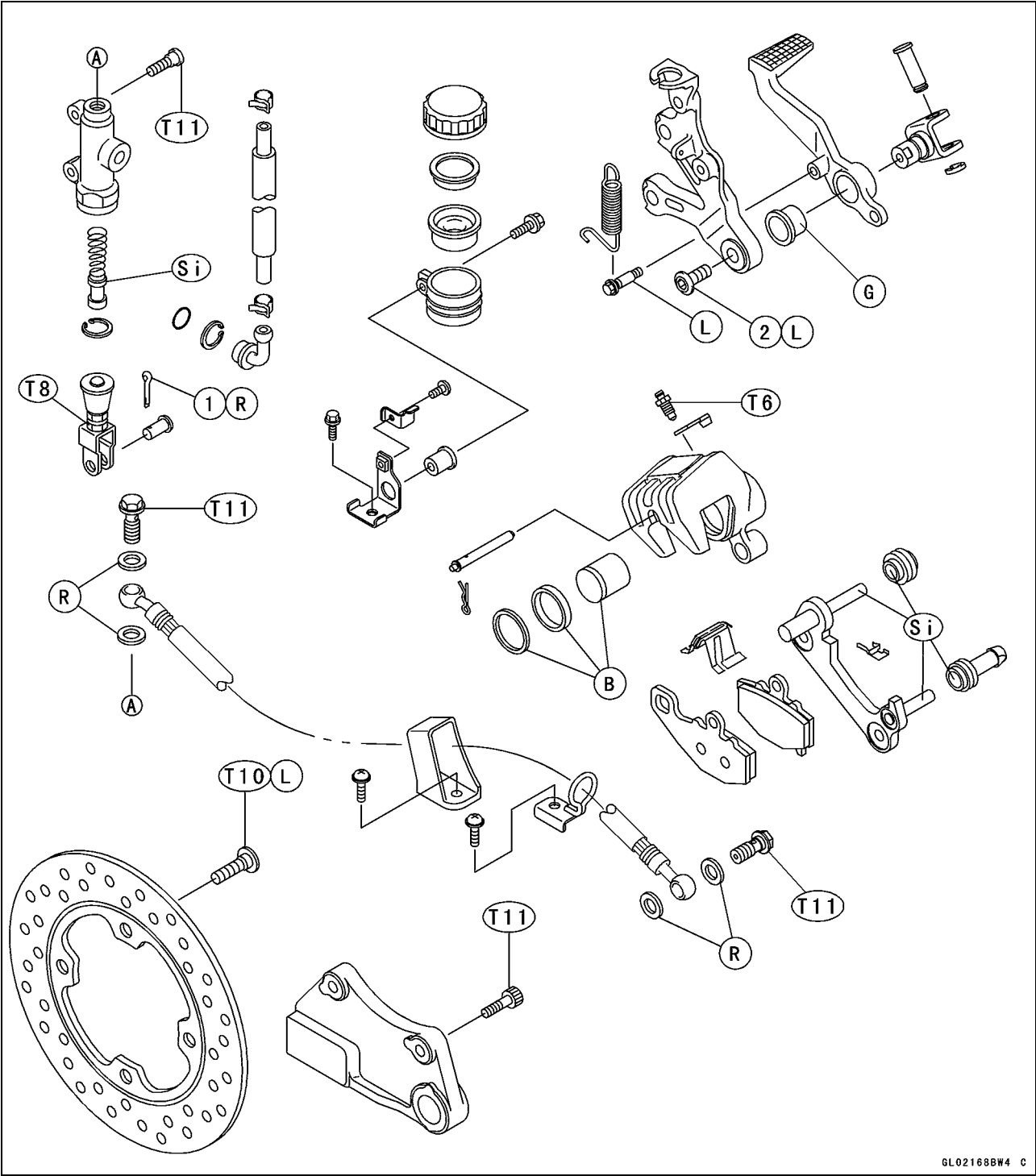

11-4 BRAKES

Specifications

Item	Standard	Service Limit
Brake Lever, Brake Pedal		
Brake Lever Position	5-way adjustable (to suit rider)	— — —
Brake Lever Free Play	Non-adjustable	— — —
Pedal Free Play	Non-adjustable	— — —
Pedal Position	About 57 mm (2.24 in.) below footpeg top	— — —
Brake Fluid		
Grade	DOT4	— — —
Brake Pads		
Lining Thickness:		
Front	4 mm (0.16 in.)	1 mm (0.04 in.)
Rear	5 mm (0.20 in.)	1 mm (0.04 in.)
Brake Discs		
Thickness:		
Front	4.8 ~ 5.1 mm (0.189 ~ 0.201 in.)	4.5 mm (0.177 in.)
Rear	4.8 ~ 5.2 mm (0.189 ~ 0.205 in.)	4.5 mm (0.177 in.)
Runout	0.15 mm (0.006 in.) or less	0.3 mm (0.012 in.)

Special Tools - Inside Circlip Pliers: 57001-143

Jack: 57001-1238

Brake Pedal

Brake Lever Position Adjustment

The brake lever adjuster has 5 positions so that the brake lever position can be adjusted to suit the operator's hand.

- Push the lever forward and turn the adjuster [A] to align the number with the arrow mark [B] on the lever holder.
- The distance from the grip to the lever is minimum at number 5 and maximum at number 1.

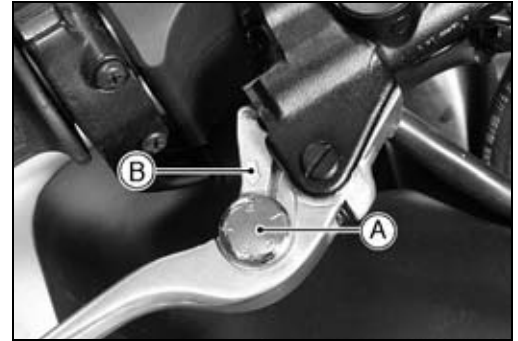

Brake Pedal Position Inspection

- Check that the brake pedal [A] is in the correct position. [B] Footpeg

Pedal Position

Standard: About 57 mm (2.24 in.) [C] below top of footpeg

- ★ If it is incorrect, adjust the brake pedal position.

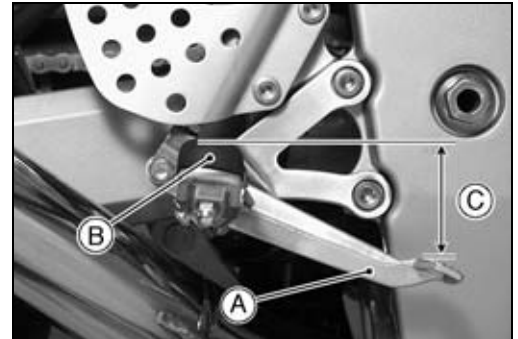

Brake Pedal Position Adjustment

NOTE

○ Usually it is not necessary to adjust the pedal position, but always adjust it when push rod locknut has been loosened.

- Remove the rear master cylinder cover [B], and then tighten the master cylinder bolts [A] only.



- Loosen the locknut [A] and turn the push rod with the hex head [B] to achieve the correct pedal position.
- ★ If the length [C] shown is 65 ± 1 mm (2.56 ± 0.04 in.), the pedal position will be within the standard range.
- Tighten:

Torque - Rear Master Cylinder Push Rod Locknut: 18 N·m (1.8 kgf·m, 13 ft·lb)

- Check the brake light switch operation (see Electrical System chapter).

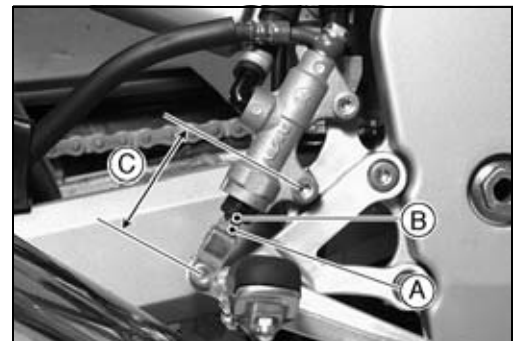

11-6 BRAKES

Calipers

Front Caliper Removal

- Loosen the banjo bolt [A] at the brake hose lower end, and tighten it loosely.
- Unscrew the caliper mounting bolts [B], and detach the caliper [C] from the disc.

CAUTION

Do not loosen the caliper assembly bolts [D]. Take out only the caliper mounting bolts for caliper removal. Loosening the caliper assembly bolts will cause brake fluid leakage.

- Unscrew the banjo bolt and remove the brake hose [E] from the caliper (see Brake Hose Removal/Installation).

CAUTION

Immediately wash away any brake fluid that spills.

NOTE

○If the caliper is to be disassembled after removal and if compressed air is not available, disassemble the caliper before the brake hose is removed (see Front Caliper Disassembly).

Rear Caliper Removal

- Loosen the banjo bolt [A] at the brake hose lower end, and tighten it loosely.
- Unscrew the caliper mounting bolts [B], and detach the caliper [C] from the disc.
- Unscrew the banjo bolt and remove the brake hose [D] from the caliper (see Brake Hose Removal/Installation).

CAUTION

Immediately wash away any brake fluid that spills.

NOTE

○If the caliper is to be disassembled after removal and if compressed air is not available, disassemble the caliper before the brake hose is removed (see Rear Caliper Disassembly).

Caliper Installation

- Install the caliper and brake hose lower end.
- Replace the washers on each side of hose fitting with new ones.
- Tighten:

Torque - Front Caliper Mounting Bolts: 34 N·m (3.5 kgf·m, 25 ft·lb)

Rear Caliper Mounting Bolts: 25 N·m (2.5 kgf·m, 18 ft·lb)

Brake Hose Banjo Bolts: 25 N·m (2.5 kgf·m, 18 ft·lb)

- Check the fluid level in the brake reservoirs.
- Bleed the brake line (see Bleeding the Brake Line).
- Check the brake for good braking power, no brake drag, and no fluid leakage.

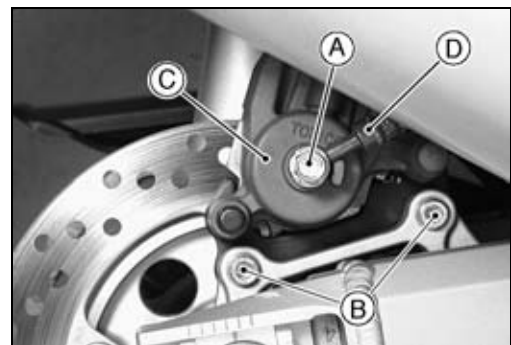
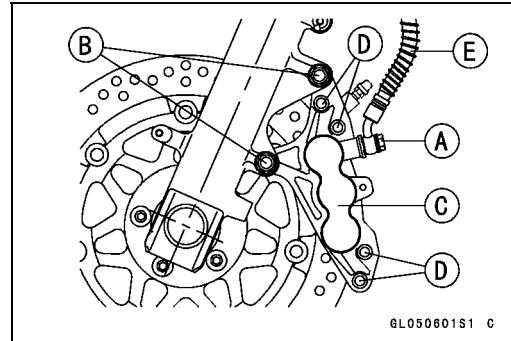

Calipers

⚠ WARNING

Do not attempt to drive the motorcycle until a full brake lever or pedal is obtained by pumping the brake lever or pedal until the pads are against the disc. The brakes will not function on the first application of the lever or pedal if this is not done.

Front Caliper Disassembly

- Loosen the front caliper assembly bolt [A] and banjo bolt [B], and tighten them loosely.
- Remove:
 - Front Caliper [C] (see Caliper Removal)
 - Brake Pads
 - Front Caliper Assembly Bolts
 - O-rings

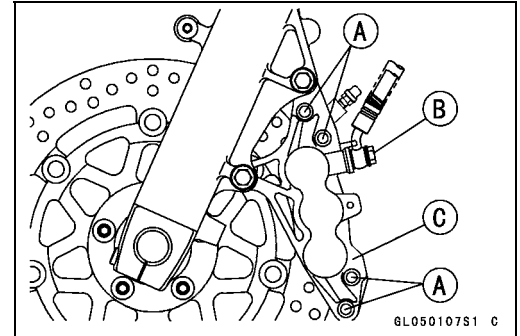

- Using compressed air, remove the pistons. One way to remove the pistons is as follows.
 - Install a rubber gasket [A] and a wooden board [B] more than 10 mm thick on the caliper half, and fasten them together with a suitable bolt and nut as shown. Leave one of the oil passages [C] open.
 - Lightly apply compressed air [D] to the oil passage until the pistons hit the rubber gasket. Block the hose joint opening [E] during this operation if the caliper half has the opening.
 - [F] Bolt and Nut
 - [G] Oil Passage sealed by Rubber Gasket.
 - [H] Push down.

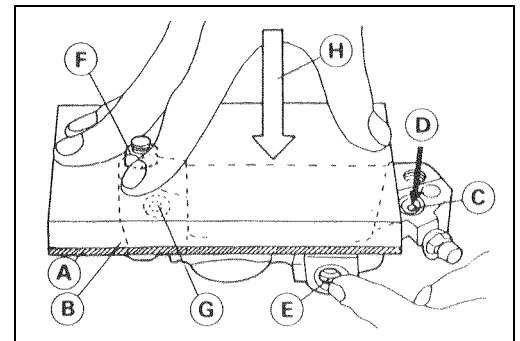
**⚠ WARNING**

To avoid serious injury, never place your fingers or palm in front of the piston. If you apply compressed air into the caliper, the piston may crush your hand or fingers.

- Pull out the pistons by hand.
- Remove the dust seals [A] and fluid seals [B].
- Remove the bleed valve [C] and rubber cap [D].
- Repeat the previous step to remove the pistons from the other side of the caliper body.

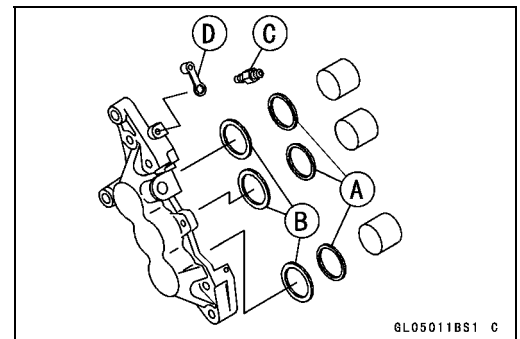
**NOTE**

- If compressed air is not available, do as follows for both calipers coincidentally, with the brake hose connected to the caliper.
- Prepare a container for brake fluid, and perform the work above it.
- Remove the spring and pads (see Front Brake Pad Removal).
- Pump the brake lever until the pistons come out of the cylinders, and then disassemble the caliper.

11-8 BRAKES

Calipers

Front Caliper Assembly

- Clean the caliper parts except for the pads.

CAUTION

For cleaning the parts, use only disc brake fluid, isopropyl alcohol, or ethyl alcohol.

- Install the bleed valve and rubber cap.
- Tighten:
 - Torque - Bleed Valve: 7.8 N·m (0.80 kgf·m, 69 in·lb)**
- Replace the fluid seals [A] with new ones.
 - Apply brake fluid to the fluid seals, and install them into the cylinders by hand.
- Replace the dust seals [B] with new ones if they are damaged.
 - Apply brake fluid to the dust seals, and install them into the cylinders by hand.

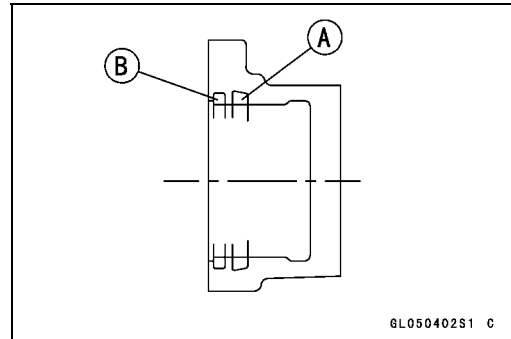

- Replace the O-rings [A] if they are damaged.
- Apply brake fluid to the outside of the pistons, and push them into each cylinder by hand.
- Be sure to install the O-rings.
- Tighten the caliper assembly bolts.

Torque - Front Caliper Assembly Bolts: 21 N·m (2.1 kgf·m, 15 ft·lb)

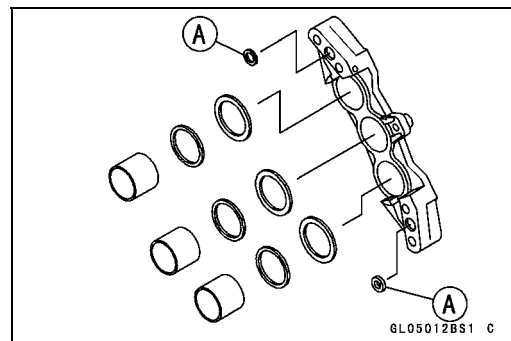

- Install the pads (see Front Brake Pad Installation).
- Wipe up any spilled brake fluid on the caliper with wet cloth.

Rear Caliper Disassembly

- Remove the rear caliper.
- Remove the pads and anti-rattle spring (see Rear Brake Pad Removal).
- Using compressed air, remove the piston.
 - Cover the caliper opening with a clean, heavy cloth [A].
 - Remove the piston by lightly applying compressed air [B] to where the brake line fits into the caliper.

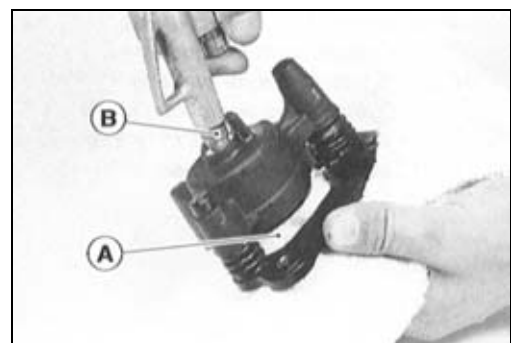

⚠ WARNING

To avoid serious injury, never place your fingers or palm inside the caliper opening. If you apply compressed air into the caliper, the piston may crush your hand or fingers.

- Remove the dust seal and fluid seal.
- Remove the bleed valve and rubber cap.

Calipers

NOTE

- If compressed air is not available, do as follows with the brake hose connected to the caliper.
- Prepare a container for brake fluid, and perform the work above it.
- Remove the pads and spring (see Rear Brake Pad Removal).
- Pump the brake pedal to remove the caliper piston.

Rear Caliper Assembly

- Clean the caliper parts except for the pads.

CAUTION

For cleaning the parts, use only disc brake fluid, isopropyl alcohol, or ethyl alcohol.

- Install the bleed valve and rubber cap.
- Tighten:
Torque - Bleed Valve: 7.8 N·m (0.80 kgf·m, 69 in·lb)

- Replace the fluid seal [A] with a new one.
- Apply brake fluid to the fluid seal, and install it into the cylinder by hand.
- Replace the dust seal [B] with a new one if it is damaged.
- Apply brake fluid to the dust seal, and install it into the cylinder by hand.

- Apply brake fluid to the outside of the piston, and push it into the cylinder by hand.
- Replace the shaft rubber boot [A] and dust cover [B] if they are damaged.
- Apply a thin coat of PBC (Poly Butyl Cuprysil) grease to the caliper holder shafts [C] and holder holes [D] (PBC is a special high temperature, water-resistance grease).

- Install the anti-rattle spring [A] in the caliper as shown.
- Install the pads (see Rear Brake Pad Installation).
- Wipe up any spilled brake fluid on the caliper with wet cloth.

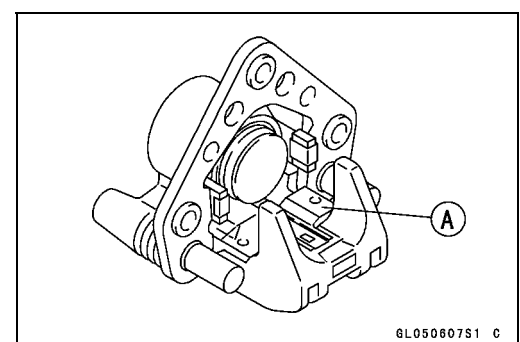
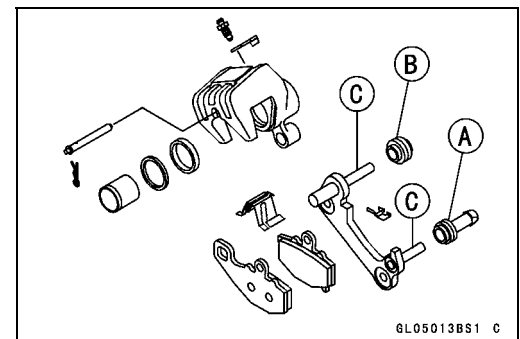
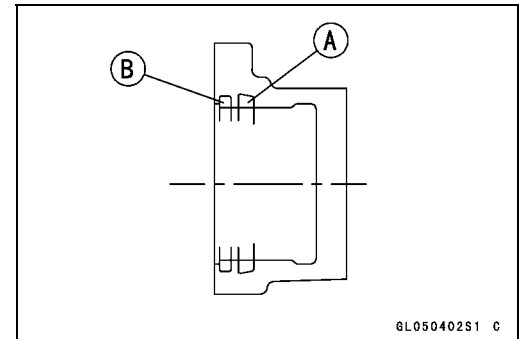

11-10 BRAKES

Calipers

Caliper Fluid Seal Damage Inspection

The fluid seals [A] around the piston maintain the proper pad/disc clearance. If the seals are not satisfactory, pad wear will increase, and constant pad drag on the disc will raise brake and brake fluid temperature.

- Replace the fluid seals under any of the following conditions: (a) fluid leakage around the pad; (b) brakes over-heat (c) there is a large difference in inner and outer pad wear; (d) the seal is stuck to the piston.
- ★ If the fluid seal is replaced, replace the dust seal as well. Also, replace all seals every other time the pads are changed.

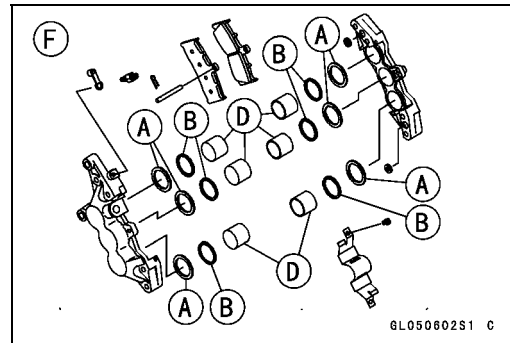

Caliper Dust Seal/Rubber Boot Damage Inspection

- Check that the dust seals [B] and rubber boot [C] are not cracked, worn, swollen, or otherwise damaged.
- If they show any damage, remove the caliper bracket and replace them.

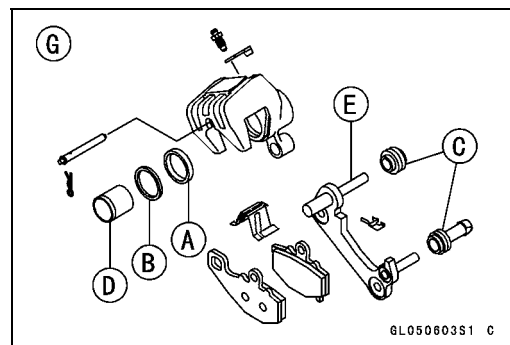

Caliper Piston and Cylinder Damage Inspection

- Visually inspect the piston [D] and cylinder surfaces.
 - ★ Replace the caliper if the cylinder and piston are badly scored or rusty.
- Front Caliper [F]
Rear Caliper [G]

Caliper Holder Shaft Wear Inspection

The caliper body must slide smoothly on the caliper holder shafts [E]. If the body does not slide smoothly, one pad will wear more than the other, pad wear will increase, and constant drag on the disc will raise brake and brake fluid temperature.

- Check to see that the caliper holder shafts are not badly worn or stepped, and that the rubber boots are not damaged.
- ★ If the rubber boot is damaged, replace the rubber boot. To replace the rubber boot, remove the pads and the caliper bracket.
- ★ If the caliper holder shaft is damaged, replace the caliper bracket.

Brake Pads

Front Brake Pad Removal

- Remove:
 - Pad Spring Bolts [A]
 - Pad Spring [B]

Clip [A]
 Pad Pin [B]
 Brake Pads [C]

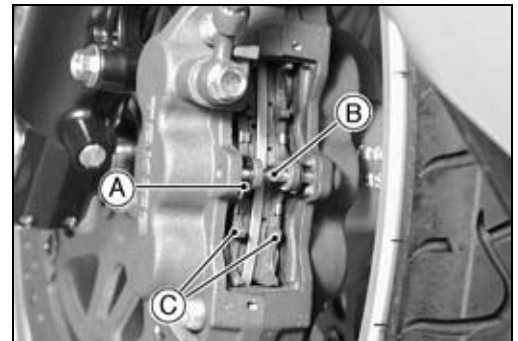
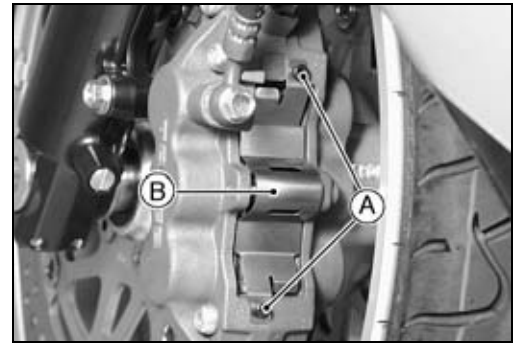

Front Brake Pad Installation

- Push the caliper pistons in by hand as far as they will go.
- Install the brake pads.
- Install the pad pin and clip. The clip must be "outside" of the pads.
- Install the pad spring and tighten the pad spring bolts.

Torque - Front Brake Pad Spring Bolts: 2.9 N·m (0.30 kgf·m, 26 in·lb)

⚠ WARNING

Do not attempt to drive the motorcycle until a full brake lever is obtained by pumping the brake lever until the pads are against the disc. The brake will not function on the first application of the lever if this is not done.

Rear Brake Pad Removal

- Remove the caliper with the hose installed.
- Remove:
 - Clip [A]
 - Pad Pin [B]
 - Brake Pads [C]

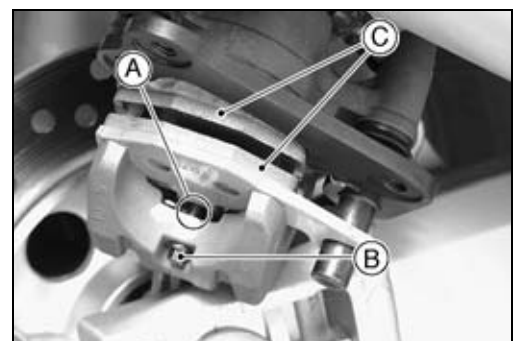

11-12 BRAKES

Brake Pads

Rear Brake Pad Installation

- Push the caliper piston in by hand as far as it will go.
- Install the anti-rattle spring in place.
- Install the brake pads.
- Install the pad pin and clip. The clip must be "outside" of the pads.
- Install the caliper (see Caliper Installation).

⚠ WARNING

Do not attempt to drive the motorcycle until a full brake pedal is obtained by pumping the brake pedal until the pads are against the disc. The brake will not function on the first application of the pedal if this is not done.

Brake Pad Wear Inspection

- Check the lining thickness [A] of the pads in each caliper.
- ★ If the lining thickness of either pad is less than the service limit [B], replace both pads in the caliper as a set.

Pad Lining Thickness

Standard:

Front	4 mm (0.16 in.)
Rear	5 mm (0.20 in.)
Service Limit:	1 mm (0.04 in.)

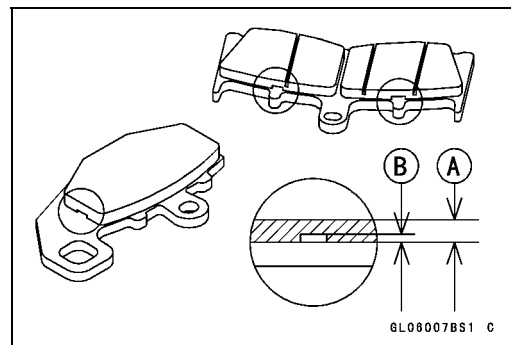

Master Cylinder

Front Master Cylinder Removal

- Loosen the reservoir bracket bolts [A].



- Disconnect the front brake light switch connectors.
- Remove the banjo bolt [A] to disconnect the brake hose from the master cylinder (see Brake Hose Removal/Installation).
- Unscrew the clamp bolts [B], and take off the master cylinder [C] as an assembly with the reservoir, brake lever, and brake switch installed.

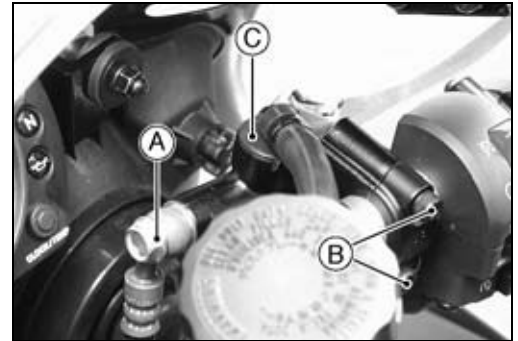

CAUTION

Immediately wash away any brake fluid that spills.

Front Master Cylinder Installation

- Set the front master cylinder to match its mating surface [A] to the punch mark [B] of the handlebar.
- The master cylinder clamp must be installed with the arrow mark [C] upward.
- Tighten the upper clamp bolt first, and then the lower clamp bolt. There will be a gap at the lower part of the clamp after tightening.

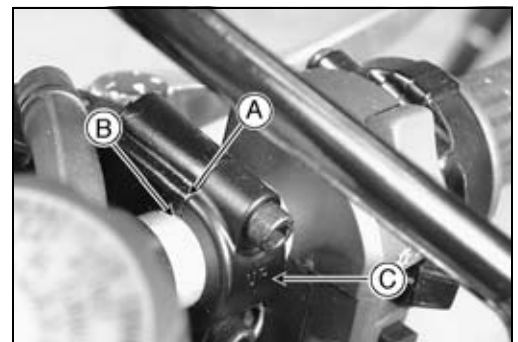

Torque - Front Master Cylinder Clamp Bolts:

8.8 N·m (0.90 kgf·m, 78 in·lb) (ZX600J1 ~ J4, J6F)

11 N·m (1.1 kgf·m, 97 in·lb) (ZX600J7F)

- Replace the washers that are on each side of the hose fitting with new ones.
- Tighten:

Torque - Brake Hose Banjo Bolts: 25 N·m (2.5 kgf·m, 18 ft·lb)

- Bleed the brake line (see Bleeding the Brake Line).
- Check the brake for good braking power, no brake drag, and no fluid leakage.

Rear Master Cylinder Removal

- Unscrew the brake hose banjo bolt [A] on the master cylinder (see Brake Hose Removal/Installation).
- Pull off the reservoir hose lower end [B], and drain the brake fluid into a container.
- Remove the cotter pin [C] and joint pin [D].

NOTE

○Pull off the joint pin while pressing down the brake pedal.

- Unscrew the master cylinder mounting bolts [E], and take off the master cylinder [F] and master cylinder cover [G].

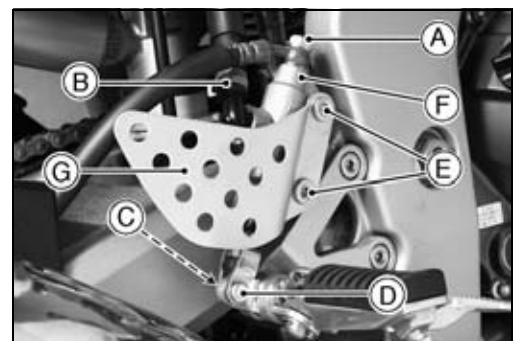

11-14 BRAKES

Master Cylinder

Rear Master Cylinder Installation

- Replace the cotter pin with a new one.
- Replace the washers that are on each side of hose fitting with new ones.
- Tighten:
 - Torque - Rear Master Cylinder Mounting Bolts: 25 N·m (2.5 kgf·m, 18 ft·lb)**
 - Brake Hose Banjo Bolts: 25 N·m (2.5 kgf·m, 18 ft·lb)**
- Bleed the brake line (see Bleeding the Brake Line).
- Check the brake for good braking power, no brake drag, and no fluid leakage.

Front Master Cylinder Disassembly

- Remove the front master cylinder (see Front Master Cylinder Removal).
- Remove the reservoir cap and diaphragm, and pour the brake fluid into a container.
- Unscrew the locknut and pivot bolt, and remove the brake lever.
- Pull the dust cover out of place, and remove the circlip.
 - Special Tool - Inside Circlip Pliers: 57001-143**
- Pull out the piston [A], secondary cup [B], primary cup [C], and return spring [D].

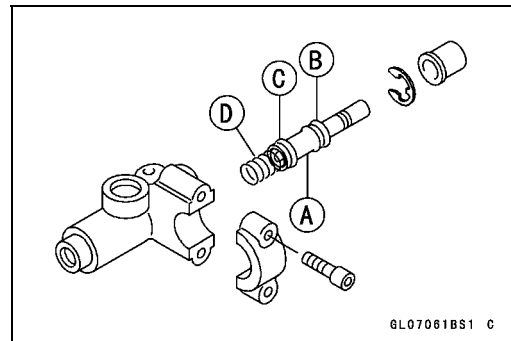

CAUTION

Do not remove the secondary cup from the piston since removal will damage it.

Rear Master Cylinder Disassembly

NOTE

○Do not remove the push rod clevis for master cylinder disassembly since removal requires brake pedal position adjustment.

- Remove the rear master cylinder (see Rear Master Cylinder Removal).
- Slide the dust cover on the push rod out of place, and remove the circlip.
- Special Tool - Inside Circlip Pliers: 57001-143**
- Pull out the push rod with the piston stop.
- Take off the piston [A], secondary cup [B], primary cup [C], and return spring [D].

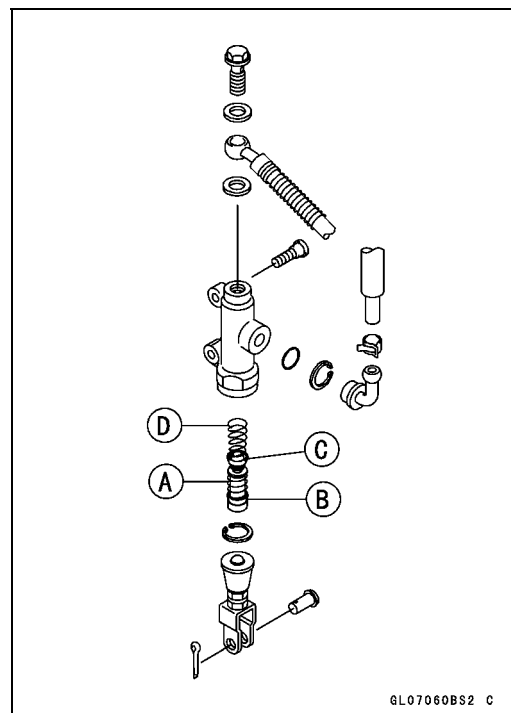

CAUTION

Do not remove the secondary cup from the piston since removal will damage it.

Master Cylinder

Master Cylinder Assembly

- Before assembly, clean all parts including the master cylinder with brake fluid or alcohol.

CAUTION

Except for the disc pads and disc, use only disc brake fluid, isopropyl alcohol, or ethyl alcohol for cleaning brake parts. Do not use any other fluid for cleaning these parts, Gasoline, engine oil, or any other petroleum distillate will cause deterioration of the rubber parts. Oil spilled on any part will be difficult to wash off completely, and will eventually deteriorate the rubber used in the disc brake.

- Apply brake fluid to the removed parts and to the inner wall of the cylinder.
- Take care not to scratch the piston or the inner wall of the cylinder.
- Apply silicone grease (ex. PBC grease)
 - Brake Lever Pivot Bolt
 - Brake Lever Pivot Contact
 - Push Rod Contact (Rear)
 - Dust Covers
- Tighten:
 - Torque - Brake Lever Pivot Bolt: 1.0 N·m (0.10 kgf·m, 9 in·lb)
 - Brake Lever Pivot Bolt Locknut: 5.9 N·m (0.60 kgf·m, 52 in·lb)

Master Cylinder Inspection (Visual Inspection)

- Disassemble the front and rear master cylinders.
 - Check that there are no scratches, rust or pitting on the inner wall [A] of each master cylinder and on the outside of each piston [B].
 - ★ If a master cylinder or piston shows any damage, replace them.
 - Inspect the primary cup [C] and secondary cup [D].
 - ★ If a cup is worn, damaged softened (rotted), or swollen, the piston assembly should be replaced to renew the cups.
 - ★ If fluid leakage is noted at the brake lever, the piston assembly should be replaced to renew the cups.
- Front Master Cylinder [J]

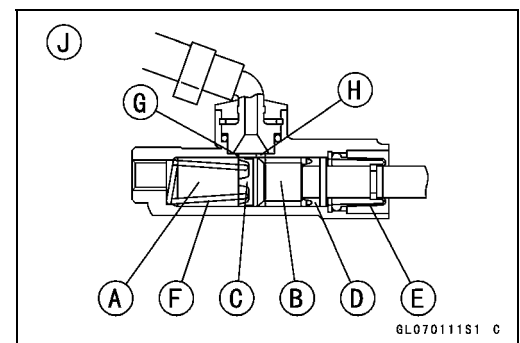

11-16 BRAKES

Master Cylinder

- Check the dust covers [E] for damage.
- ★ If they are damaged, replace them.
- Check the piston return spring [F] for any damage.
- ★ If the springs are damaged, replace them.
- Check that relief port [G] and supply port [H] are not plugged.
- ★ If the relief port becomes plugged, the brake pads will drag on the disc. Blow the ports clean with compressed air.

Rear Master Cylinder [K]

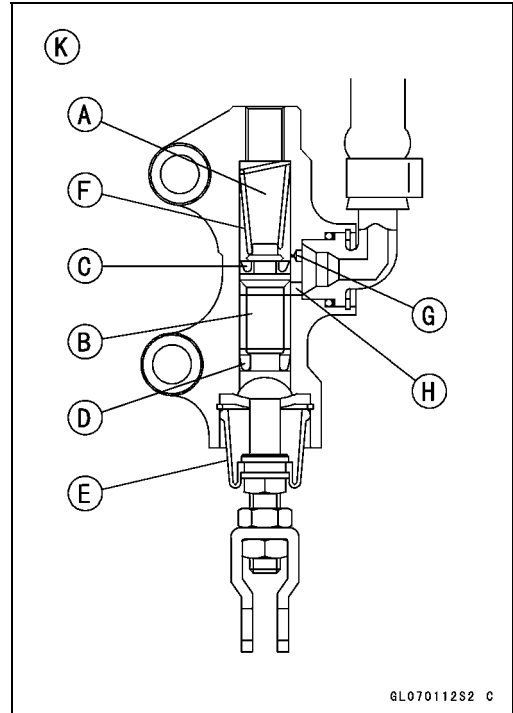

Brake Disc

Brake Disc Removal

- Remove the wheel (see Wheels/Tires chapter).
- Unscrew the mounting bolts, and take off the disc.

Brake Disc Installation

- Install the brake disc on the wheel so that the marked side [A] faces out.
- Apply a non-permanent locking agent to the threads of the rear brake disc mounting bolts [B].
- Tighten:

Torque - Brake Disc Mounting Bolts: 27 N·m (2.8 kgf·m, 20 ft·lb)

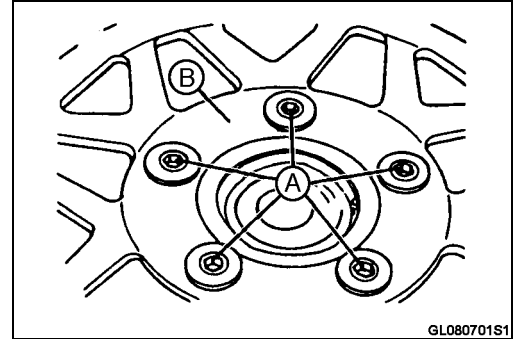

Brake Disc Wear Inspection

- Measure the thickness of each disc [A] at the point where it has worn the most.
 - ★ If the disc has worn past the service limit, replace it.
- [B] Measuring Area

Front Disc Thickness

Standard: 4.8 ~ 5.1 mm (0.189 ~ 0.201 in.)

Service Limit: 4.5 mm (0.177 in.)

Rear Disc Thickness

Standard: 4.8 ~ 5.2 mm (0.189 ~ 0.205 in.)

Service Limit: 4.5 mm (0.177 in.)

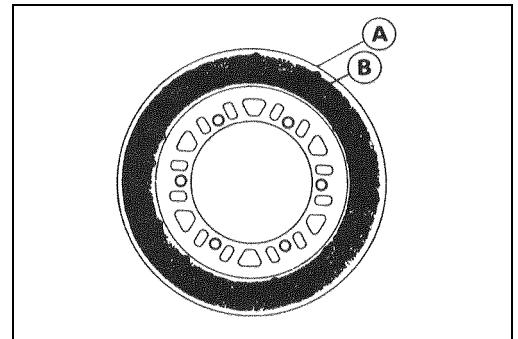

Brake Disc Warp Inspection

- Jack up the motorcycle so that the wheel is off the ground (see Wheels/Tires chapter).

Special Tool - Jack: 57001-1238

- For front disc inspection, turn the handlebar fully to one side.

- Set up a dial gauge against the disc [A] as shown and measure disc runout, while turning [B] the wheel by hand.

- ★ If runout exceeds the service limit, replace the disc.

Disc Runout

Standard: 0.15 mm 0.006 in.) or less

Service Limit: 0.3 mm (0.012 in.)

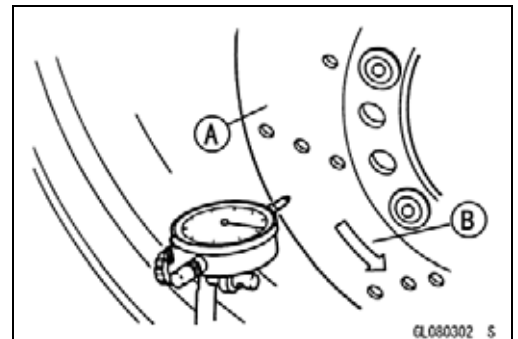

11-18 BRAKES

Brake Fluid

Level Inspection

- Check that the brake fluid level in the front brake reservoir [A] is above the lower level line [B].

NOTE

○ Hold the reservoir horizontal by turning the handlebar when checking brake fluid level.

- ★ If the fluid level is lower than the lower level line, fill the reservoir to the upper level line [C].

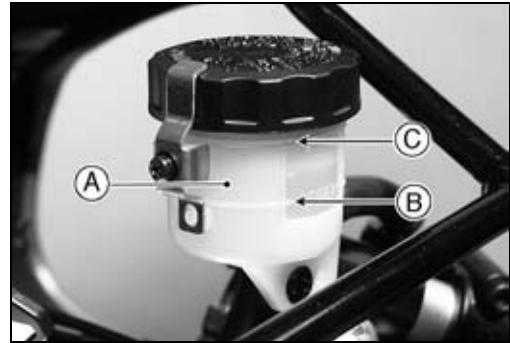

- Check that the brake fluid level in the rear brake reservoir [A] is above the lower level [B].

- ★ If the fluid level is lower than the lower level line, remove the fuel tank and fill the reservoir to the upper level line [C].

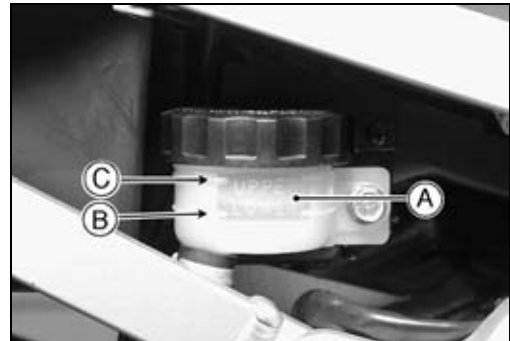

⚠ WARNING

Change the brake fluid in the brake line completely if the brake fluid must be refilled but the type and brand of the brake fluid that is already in the reservoir are unidentified. After changing the fluid, use only the same type and brand of fluid thereafter.

Recommended Disc Brake Fluid

Grade: DOT4

NOTE

- Follow the procedure shown below to install the front/rear brake fluid reservoir cap correctly.
- First, tighten the front/rear brake fluid reservoir cap [B] clockwise [C] by hand until slight resistance is felt indicating that the cap is seated on the reservoir body, then tighten the cap an additional 1/6 [D] while holding the brake fluid reservoir body [A].

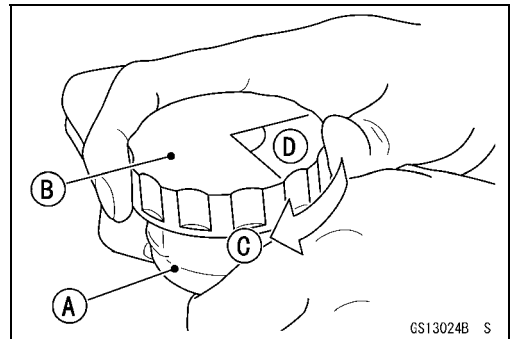

Brake Fluid Change

NOTE

- The procedure to change the front brake fluid is as follows. Changing the rear brake fluid is the same as for the front brake.

Brake Fluid

- Level the brake fluid reservoir.
- Remove the reservoir cap.
- Remove the rubber cap from the bleed valve [A] on the caliper.
- Attach a clear plastic hose [B] to the bleed valve, and run the other end of the hose into a container.
- Fill the reservoir with fresh specified brake fluid.

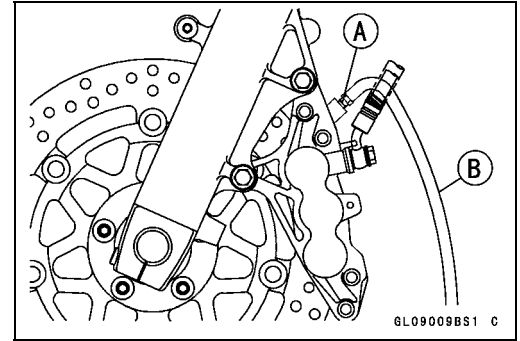

- Change the brake fluid.
- Repeat this operation until fresh brake fluid comes out from the plastic hose or the color of the fluid changes.
1. Open the bleed valve [A].
 2. Apply the brake and hold it [B].
 3. Close the bleed valve [C].
 4. Release the brake [D].

NOTE

○ *The fluid level must be checked often during the changing operation and replenished with fresh brake fluid. If the fluid in the reservoir runs out any time during the changing operation, the brakes will need to be bled since air will have entered the brake line.*

○ *Front Brake: Repeat the above steps for the other caliper.*

- Remove the clear plastic hose.
- Install the reservoir cap.
- Tighten:

Torque - Front Brake Reservoir Cap Stopper Screw: 1.5 N·m (0.15 kgf·m, 13 in·lb)

- Tighten the bleed valve, and install the rubber cap.
- After changing the fluid, check the brake for good braking power, no brake drag, and no fluid leakage.

Torque - Bleed Valve: 7.8 N·m (0.80 kgf·m, 69 in·lb)

★ If necessary, bleed the air from the lines.

Bleeding the Brake Line

The brake fluid has a very low compression coefficient so that almost all the movement of the brake lever or pedal is transmitted directly to the caliper for braking action. Air, however, is easily compressed. When air enters the brake lines, brake lever or pedal movement will be partially used in compressing the air. This will make the lever or pedal feel spongy, and there will be a loss in braking power.

⚠ WARNING

Be sure to bleed the air from the brake line whenever brake lever or pedal action feels soft or spongy after the brake fluid is changed, or whenever a brake line fitting has been loosened for any reason.

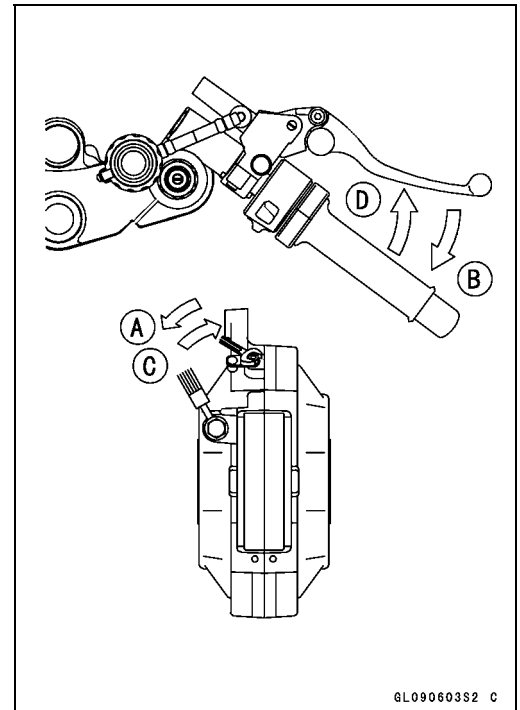

11-20 BRAKES

Brake Fluid

NOTE

○ *The procedure to bleed the front brake line is as follows. Bleeding the rear brake line is the same as for the front brake.*

- Remove the reservoir cap, and fill the reservoir with fresh brake fluid to the upper level line in the reservoir.
- With the reservoir cap off, slowly pump the brake lever several times until no air bubbles can be seen rising up through the fluid from the holes at the bottom of the reservoir.
- Bleed the air completely from the master cylinder by this operation.
- Install the reservoir cap.
- Remove the rubber cap from the bleed valve on the caliper.
- Attach a clear plastic hose to the bleed valve, and run the other end of the hose into a container.
- Bleed the brake line and the caliper.
- Repeat this operation until no more air can be seen coming out into the plastic hose.
 1. Pump the brake lever until it becomes hard, and apply the brake and hold it [A].
 2. Quickly open and close [B] the bleed valve while holding the brake applied.
 3. Release the brake [C].

NOTE

○ *The fluid level must be checked often during the bleeding operation and replenished with fresh brake fluid as necessary. If the fluid in the reservoir runs completely out any time during bleeding, the bleeding operation must be done over again from the beginning since air will have entered the line.*

○ *Tap the brake hose lightly from the caliper to the reservoir for more complete bleeding.*

○ *Front Brake: Repeat the above steps for the other caliper.*

- Remove the clear plastic hose.
- Tighten:
 - Torque - Front Brake Reservoir Cap Stopper Screw: 1.5 N·m (0.15 kgf·m, 13 in·lb)**
- Tighten the bleed valve, and install the rubber cap.
 - Torque - Bleed Valve: 7.8 N·m (0.80 kgf·m, 69 in·lb)**
- Check the fluid level.
- After bleeding is done, check the brake for good braking power, no brake drag, and no fluid leakage.

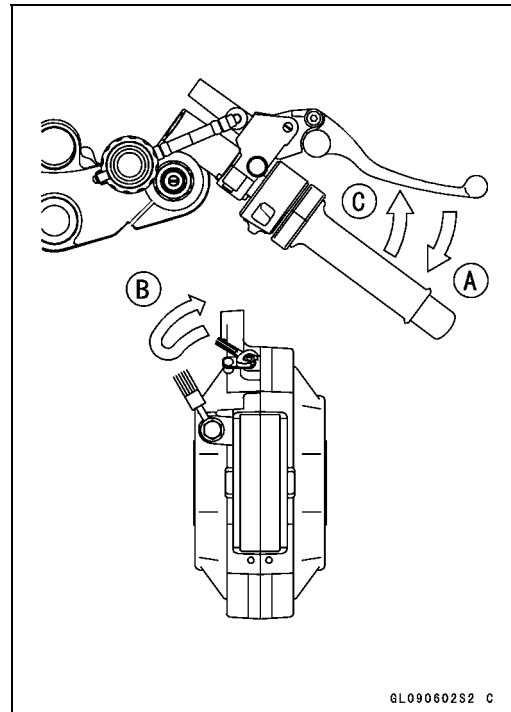

Brake Fluid

⚠ WARNING

When working with the disc brake, observe the precautions listed below.

1. Never reuse old brake fluid.
2. Do not use fluid from a container that has been left unsealed or that has been open for a long time.
3. Do not mix two types and brands of fluid for use in the brake. This lowers the brake fluid boiling point and could cause the brake to be ineffective. It may also cause the rubber brake parts to deteriorate.
4. Don't leave the reservoir cap off for any length of time to avoid moisture contamination of the fluid.
5. Don't change the fluid in the rain or when a strong wind is blowing.
6. Except for the disc pads and disc, use only disc brake fluid, isopropyl alcohol, or ethyl alcohol for cleaning brake parts. Do not use any other fluid for cleaning these parts. Gasoline, engine oil, or any other petroleum distillate will cause deterioration of the rubber parts. Oil spilled on any part will be difficult to wash off completely and will eventually deteriorate the rubber used in the disc brake.
7. When handling the disc pads or disc, be careful that no disc brake fluid or any oil gets on them. Clean off any fluid or oil that inadvertently gets on the pads or disc with a high-flash point solvent. Do not use one which will leave an oily residue. Replace the pads with new ones if they cannot be cleaned satisfactorily.
8. Brake fluid quickly ruins painted surfaces; any spilled fluid should be completely wiped up immediately.
9. If any of the brake line fittings or the bleed valve is opened at any time, the **AIR MUST BE BLED FROM THE BRAKE LINE.**

11-22 BRAKES

Brake Hose

Brake Hose Removal/Installation

CAUTION
Brake fluid quickly ruins painted or plastic surfaces; any spilled fluid should be completely wiped up immediately with wet cloth.

- When removing the brake hose, take care not to spill the brake fluid on the painted or plastic parts.
- When removing the brake hose, temporarily secure the end of the brake hose to some high place to keep fluid loss to a minimum.
- There are washers on each side of the brake hose fitting. Replace them with new ones when installing.
- When installing the hoses, avoid sharp bending, kinking, flattening or twisting, and route the hoses according to Cable, Wire, and Hose Routing section in General Information chapter.
- Tighten:
Torque - Brake Hose Banjo Bolts: 25 N·m (2.5 kgf·m, 18 ft·lb)
- Bleed the brake line after installing the brake hose (see Bleeding the Brake Line).

Brake Hose Inspection

- The high pressure inside the brake line can cause fluid to leak or the hose to burst if the line is not properly maintained. Bend and twist the rubber hose while examining it.
- ★ Replace it if any cracks or bulges are noticed.

Suspension

Table of Contents

Exploded View	12-2
Specifications	12-4
Front Fork.....	12-6
Rebound Damping Force Adjustment.....	12-6
Compression Damping Force Adjustment	12-6
Spring Preload Adjustment	12-7
Front Fork Removal (each fork leg)	12-8
Front Fork Installation	12-8
Fork Oil Change.....	12-8
Front Fork Disassembly	12-11
Front Fork Assembly.....	12-12
Inner Tube, Outer Tube Inspection	12-13
Dust Seal Inspection	12-14
Spring Tension	12-14
Rear Shock Absorber	12-15
Rebound Damping Force Adjustment.....	12-15
Compression Damping Force Adjustment	12-15
Spring Preload Adjustment	12-16
Rear Shock Absorber Removal	12-16
Rear Shock Absorber Installation	12-17
Rear Shock Absorber Inspection	12-17
Rear Shock Absorber Scrapping	12-17
Swingarm.....	12-18
Swingarm Removal.....	12-18
Swingarm Installation.....	12-18
Swingarm Bearing Removal	12-18
Swingarm Bearing Installation	12-18
Swingarm Bearing, Sleeve Inspection	12-19
Swingarm Lubrication	12-19
Tie-Rod, Rocker Arm.....	12-20
Tie-Rod Removal	12-20
Tie-Rod Installation	12-20
Rocker Arm Removal.....	12-20
Rocker Arm Installation.....	12-20
Rocker Arm/Tie-Rod Bearing, Sleeve Inspection	12-21
Rocker Arm/Tie-Rod Lubrication.....	12-21

12-2 SUSPENSION

Exploded View

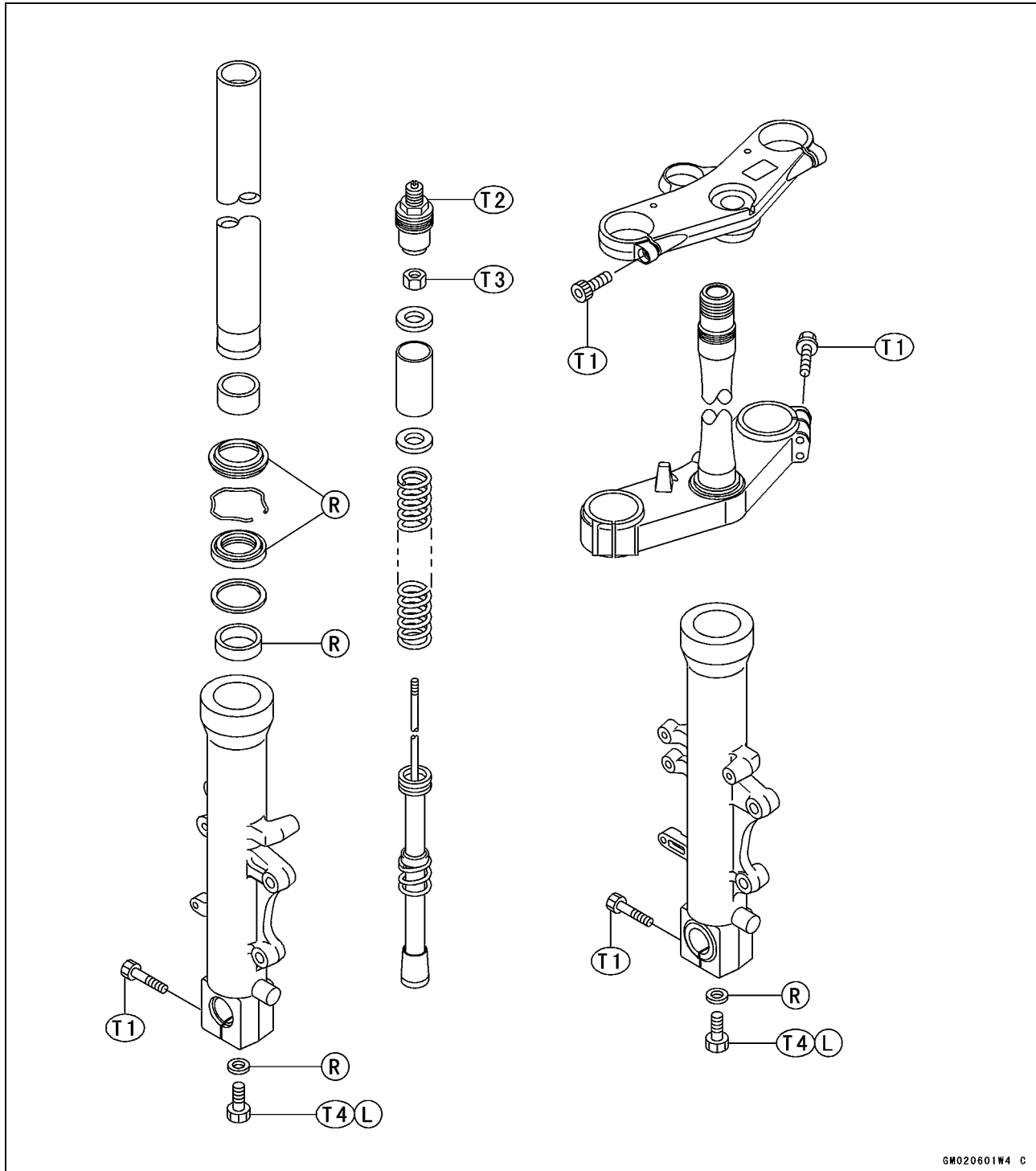

- T1: 20 N·m (2.0 kgf·m, 14.5 ft·lb)
- T2: 23 N·m (2.3 kgf·m, 16.5 ft·lb)
- T3: 28 N·m (2.9 kgf·m, 21 ft·lb)
- T4: 39 N·m (4.0 kgf·m, 29 ft·lb)
- L: Apply a non-permanent locking agent.
- R: Replacement Parts

Exploded View

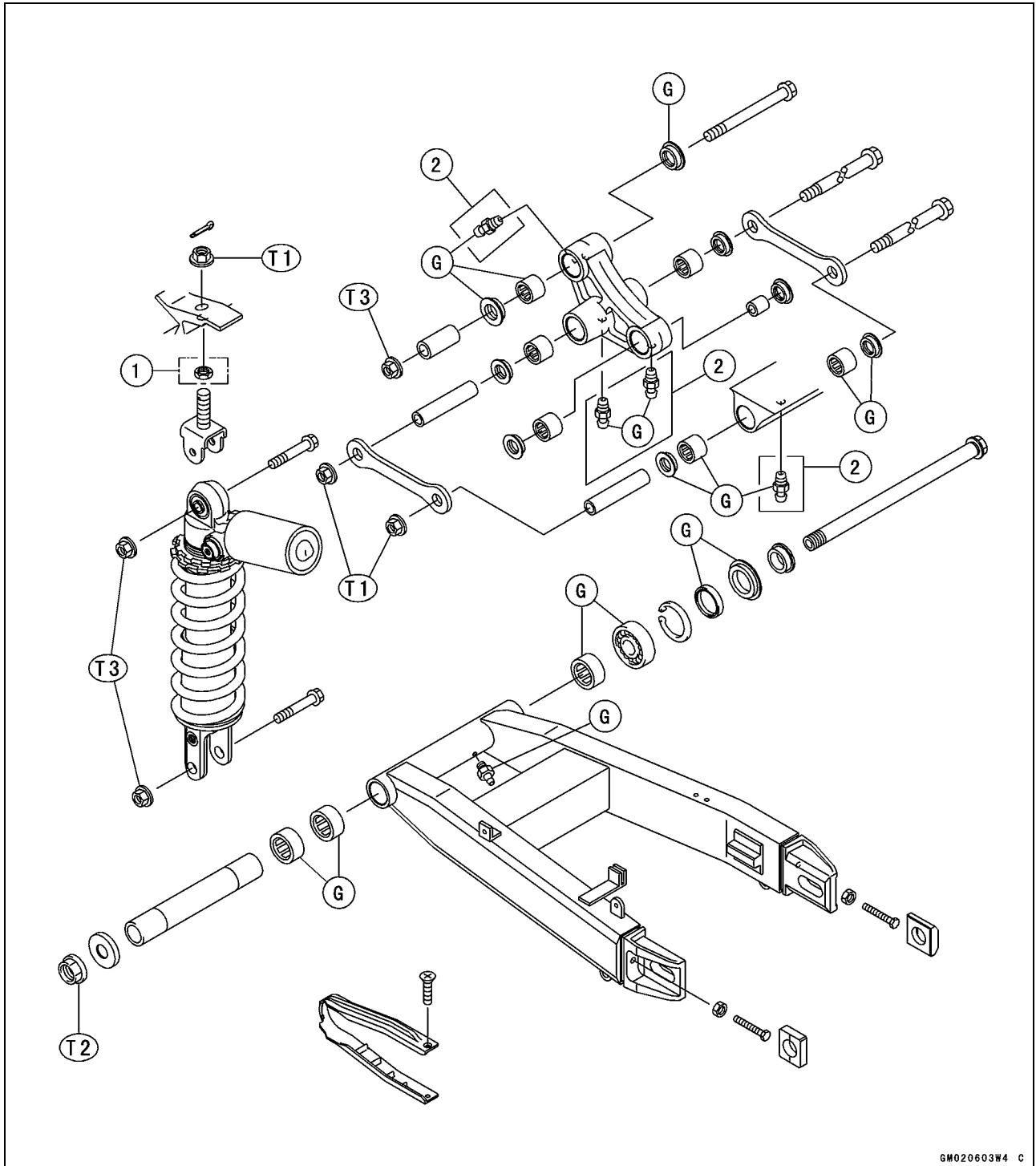

GM020603W4 C

T1: 59 N·m (6.0 kgf·m, 43 ft·lb)

T2: 108 N·m (11 kgf·m, 80 ft·lb)

T3: 34 N·m (3.5 kgf·m, 25 ft·lb)

G: Apply or add grease.

1. Nut (ZX600-J1 Model)

Washer (ZX600-J2 ~ Model)

2. Grease Nipple (ZX600-J1 ~ J3 Models)

12-4 SUSPENSION

Specifications

Item	Standard
Front Fork (Per One Unit)	
Fork Inner Tube Diameter	φ46 mm (1.81 in.)
Air Pressure	Atmospheric pressure (Non-adjustable)
Rebound Damper Setting	7th click from the first click of the fully clockwise position (ZX600-J1 ~ J3) (Usable Range: 1 ←→ 12 clicks) 1 1/2 turns out from fully clockwise position (ZX600-J4 ~ (US), ZX600J6F ~ (CA)) (Usable Range: fully clockwise position ~ 3 turns out)
Compression Damper Setting	9th click from the first click of the fully clockwise position (ZX600-J1 ~ J3) (Usable Range: 1 ←→ 12 clicks) 2 turns out from fully clockwise position (ZX600-J4 ~ (US), ZX600J6F ~ (CA)) (Usable Range: fully clockwise position ~ 3 turns out)
Fork Spring Preload Setting	Adjuster protrusion is 14 mm (0.55 in.) (Usable Range: 5 ~ 20 mm (0.20 ~ 0.79 in.))
Fork Oil Viscosity	KHL34 (KAYABA G10) or equivalent
Fork Oil Capacity	537 ±4 mL (18.2 ±0.1 US oz) (completely dry) (ZX600-J1 ~ J3) 541 ±4 mL (18.3 ±0.1 US oz) (completely dry) (ZX600-J4 ~ (US), ZX600J6F ~ (CA)) approx. 455 mL (15.4 US oz) (when changing oil) (ZX600-J1 ~ J3) approx. 459 mL (15.5 US oz) (when changing oil) (ZX600-J4 ~ (US), ZX600J6F ~ (CA))
Fork Oil Level	Fully compressed, without fork spring, below from inner tube top 116 ±2 mm (4.57 ±0.08 in.) (ZX600-J1 ~ J3) Fully compressed, without fork spring, below from inner tube top 113 ±2 mm (4.45 ±0.08 in.) (ZX600-J4 ~ (US), ZX600J6F ~ (CA))
Fork Spring Free Length	234.6 mm (9.24 in.) (Service limit 230 mm (9.06 in.))
Rear Shock Absorber	
Rebound Damper Set	10th click from the first click of the fully clockwise position (ZX600-J1 ~ J3) (Usable Range: 1 ←→ 18 clicks) 2 1/2 turns out from fully clockwise position (ZX600-J4 ~ (US), ZX600J6F ~ (CA)) (Usable Range: fully clockwise position ~ 5 turns out)
Compression Damper Set	10th click from the first click of the fully clockwise position (ZX600-J1 ~ J3) (Usable Range: 1 ←→ 20 clicks) 2 1/2 turns out from fully clockwise position (ZX600-J4 ~ (US), ZX600J6F ~ (CA)) (Usable Range: fully clockwise position ~ 4 1/2 turns out)

Specifications

Item	Standard
Spring Preload Setting Position	
Standard	Spring length 180 mm (7.09 in.)
Usable Range	Spring length 182 mm (7.17 in.) to 170 mm (6.69 in.) (weaker to stronger)
Gas Pressure	980 kPa (10 kg/cm ² , 142 psi, Non-adjustable)

CA: Canada Model

US: United States Model

- Special Tools - Fork Piston Rod Puller, M12 × 1.25: 57001-1289**
Fork Oil Level Gauge: 57001-1290
Fork Outer Tube Weight: 57001-1218
Fork Cylinder Holder, Hex 24 × □19.5: 57001-1406
Front Fork Oil Seal Driver: 57001-1219
Hook Wrench: 57001-1101
Oil Seal & Bearing Remover: 57001-1058
Bearing Driver Set: 57001-1129
Inside Circlip Pliers: 57001-143
Jack: 57001-1238

12-6 SUSPENSION

Front Fork

Rebound Damping Force Adjustment

ZX600-J1 ~ J3

- To adjust the rebound damping force, turn the rebound damping adjuster [A] until you feel a click.
- The standard adjuster setting for the average-build rider of 68 kg (150 lb) with no passenger and no accessories is the **7th click** from the 1st click of the fully clockwise position.

ZX600-J4 ~ (US), ZX600J6F ~ (CA)

- To adjust the rebound damping force, turn the rebound damping adjuster [A] up to the specified turns.
- The standard adjuster setting for the average-build rider of 68 kg (150 lb) and with no passenger and accessories is 1 1/2 turns out from fully clockwise position.



⚠ WARNING

If both adjusters are not adjusted equally, handling may be impaired and a hazardous condition may result.

- The damping force can be left soft for average riding. But it should be adjusted harder for high speed riding or riding with a passenger. If the damping feels too soft or too stiff, adjust it in accordance with the following table.

Rebound Damping Force Adjustment

Adjuster Position	Damping Force	Setting	Load	Road	Speed
A	Weak	Soft	Light	Good	Low
↑	↑	↑	↑	↑	↑
↓	↓	↓	↓	↓	↓
B	Strong	Hard	Heavy	Bad	High

- A: 12 clicks (ZX600-J1 ~ J3)
3 turns out (ZX600-J4 ~ (US), ZX600J6F ~ (CA))
- B: 1 click (ZX600-J1 ~ J3)
Fully clockwise position (ZX600-J4 ~ (US), ZX600J6F ~ (CA))

Compression Damping Force Adjustment

ZX600-J1 ~ J3

- To adjust the compression damping force, turn the compression damping adjuster [A] until you feel a click.
- The standard adjuster setting for the average-build rider of 68 kg (150 lb) with no passenger and no accessories is the **9th click** from the 1st click of the fully clockwise position.

ZX600-J4 ~ (US), ZX600J6F ~ (CA)

- To adjust the compression damping force, turn the rebound damping adjuster [A] up to the specified turns.
- The standard adjuster setting for the average-build rider of 68 kg (150 lb) and with no passenger and accessories is 2 turns out from fully clockwise position.

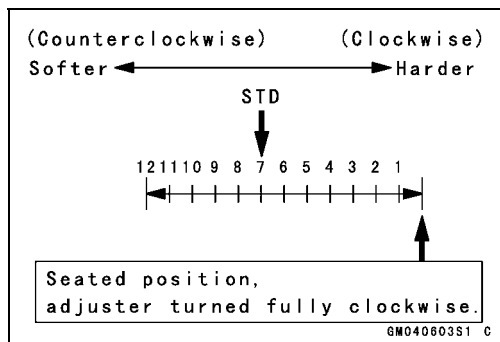
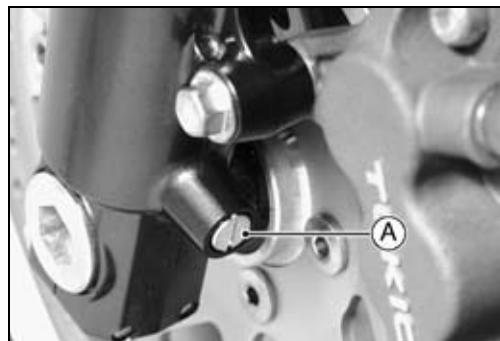

⚠ WARNING

If both adjusters are not adjusted equally, handling may be impaired and a hazardous condition may result.

Front Fork

○The damping force can be left soft for average riding. But it should be adjusted harder for high speed riding or riding with a passenger. If the damping feels too soft or too stiff, adjust it in accordance with the following table.

Compression Damping Force Adjustment

Adjuster Position	Damping Force	Setting	Load	Road	Speed
A	Weak	Soft	Light	Good	Low
↑	↑	↑	↑	↑	↑
↓	↓	↓	↓	↓	↓
B	Strong	Hard	Heavy	Bad	High

- A: 12 clicks (ZX600-J1 ~ J3)
3 turns out (ZX600-J4 ~ (US), ZX600J6F ~ (CA))
- B: 1 click (ZX600-J1 ~ J3)
Fully clockwise position (ZX600-J4 ~ (US), ZX600J6F ~ (CA))

Spring Preload Adjustment

- Turn the spring preload adjuster [A] to change spring preload setting.
- The standard adjuster setting for the average-build rider of 68 kg (150 lb) with no passenger and no accessories is the 14 mm [B] from top as shown.

Adjuster Protrusion (from top)

- Standard: 14 mm (0.55 in.)
- Usable Range: 5 ~ 20 mm (0.20 ~ 0.79 in.)

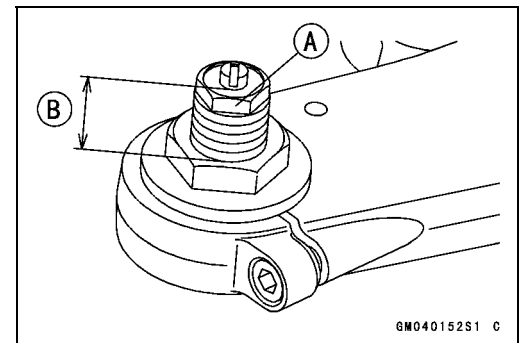
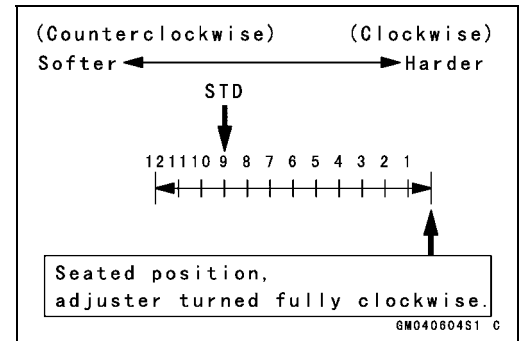

⚠ WARNING

If both adjusters are not adjusted equally, handling may be impaired and a hazardous condition may result.

○The spring preload can be left soft for average riding. But it should be adjusted harder for high speed riding or riding with a passenger. If the spring action feels too soft or too stiff, adjust it in accordance with the following table.

Spring Action

Adjuster Position	Damping Force	Setting	Load	Road	Speed
20 mm	Weak	Soft	Light	Good	Low
↑	↑	↑	↑	↑	↑
↓	↓	↓	↓	↓	↓
5mm	Strong	Hard	Heavy	Bad	High

12-8 SUSPENSION

Front Fork

Front Fork Removal (each fork leg)

- Remove:
 - Lower and Upper Fairings (see Frame chapter)
 - Front Wheel (see Wheels/Tires chapter)
 - Front Fender (see Frame chapter)
- ★ Loosen the handlebar holder bolt [A], upper fork clamp bolt [B] and fork top plug [C] beforehand if the fork leg is to be disassembled.

NOTE

○ Loosen the top plug after loosening the handlebar holder bolt and upper fork clamp bolt.

- Loosen the handlebar holder bolt [A], upper fork clamp bolt [B] and lower fork clamp bolts [C].
- With a twisting motion, work the fork leg down and out.

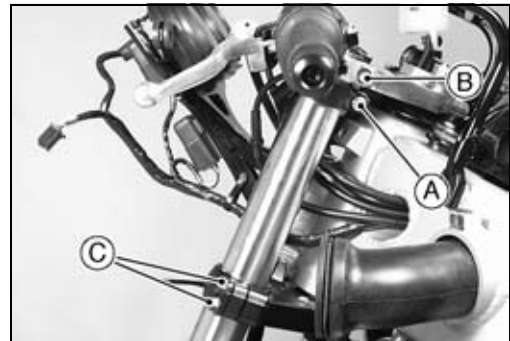

Front Fork Installation

- Install the fork so that the top end [A] of the inner tube is flush with the upper surface [B] of the steering stem head.
- Tighten:
 - Torque - Front Fork Clamp Bolts (Lower): 20 N·m (2.0 kgf·m, 14.5 ft·lb)**
 - Front Fork Top Plugs: 23 N·m (2.3 kgf·m, 16.5 ft·lb)**

NOTE

○ Tighten the top plug before tightening the handlebar holder bolt and upper fork clamp bolt.

- Tighten:
 - Torque - Handlebar Holder Bolts: 25 N·m (2.5 kgf·m, 18 ft·lb)**
 - Front Fork Clamp Bolts (Upper): 20 N·m (2.0 kgf·m, 14.5 ft·lb)**
- Adjust the spring preload and the damping force.

Fork Oil Change

- Remove the front fork (see Front Fork Removal).
- Turn the spring preload adjuster [A] counterclockwise until the fully position.
- Unscrew the top plug [B] out of the inner tube.

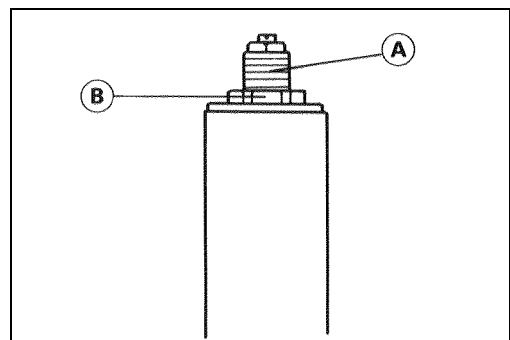
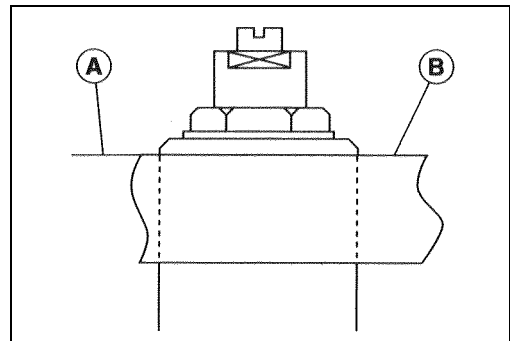

Front Fork

- Holding the piston rod nut [A] with a wrench [B], remove the fork top plug from the piston rod.

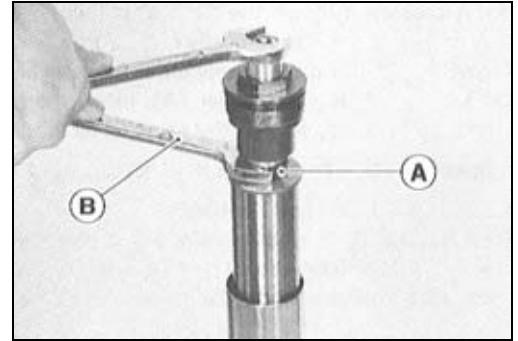

- Remove:
Rebound Damping Adjuster Rod [A]
Washer [B]
Spacer [C]

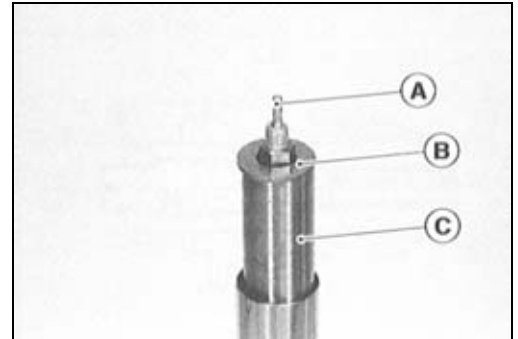

Washer [A]
Fork Spring [B]

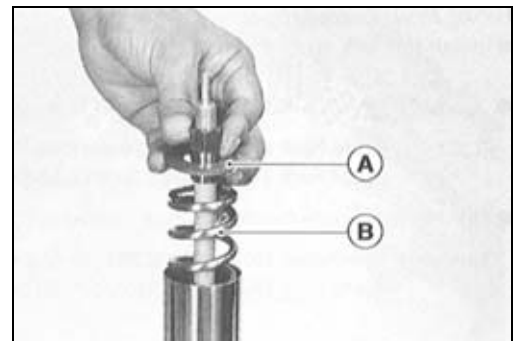

- Drain the fork oil into a suitable container.
- Pump the piston rod [B] up and down at least ten times to expel the oil from the fork.

Special Tool - Fork Piston Rod Puller, M12 × 1.25: 57001-1289 [A]

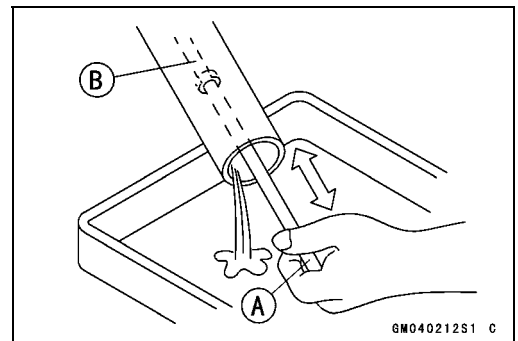

12-10 SUSPENSION

Front Fork

- Hold the fork tube upright, press the inner tube and the piston rod all the way down.
- Pour in the type and amount of fork oil specified.

Fork Oil

Viscosity: KHL34 (KAYABA G10) or equivalent

Amount (per side)

When changing oil: approx. 455 mL (15.4 US oz)
(ZX600-J1 ~ J3)

approx. 459 mL (15.5 US oz)
(ZX600-J4 ~ (US), ZX600J6F ~ (CA))

After disassembly and completely dry: 537 ±4 mL (18.2 ±0.1 US oz)
(ZX600-J1 ~ J3)

541 ±4 mL (18.3 ±0.1 US oz)
(ZX600-J4 ~ (US), ZX600J6F ~ (CA))

★ If necessary, measure the oil level as follows.

- Hold the outer tube vertically in a vise.
- Pump the inner tube several times to expel air bubbles.
- Using the piston rod puller [A], move the piston rod [B] up and down more than ten times in order to expel all the air from the fork oil.

Special Tool - Fork Piston Rod Puller, M12 × 1.25: 57001-1289

- Wait until the oil level settles.
- With the fork fully compressed and the piston rod fully pushed in, insert a tape measure or rod into the inner tube, and measure the distance from the top of the inner tube to the oil.

Oil Level (fully compressed, without spring)

Standard: 116 ±2 mm (4.57 ±0.08 in.) (from the top of the inner tube) (ZX600-J1 ~ J3)

113 ±2 mm (4.45 ±0.08 in.) (from the top of the inner tube) (ZX600-J4 ~ (US), ZX600J6F ~ (CA))

NOTE

- Fork oil level may also be measured using the fork oil level gauge.

Special Tool - Fork Oil Level Gauge: 57001-1290 [A]

- With the fork fully compressed and without fork spring, insert the gauge tube into the inner tube [B] and position the stopper across the top end of the inner tube.
- Set the gauge stopper [C] so that its lower side shows the oil level distance specified [D].
- Pull the handle slowly to pump out the excess oil until the oil no longer comes out.
- ★ If no oil is pumped out, there is insufficient oil in the inner tube. Pour in enough oil, then pump out the excess oil as shown above.

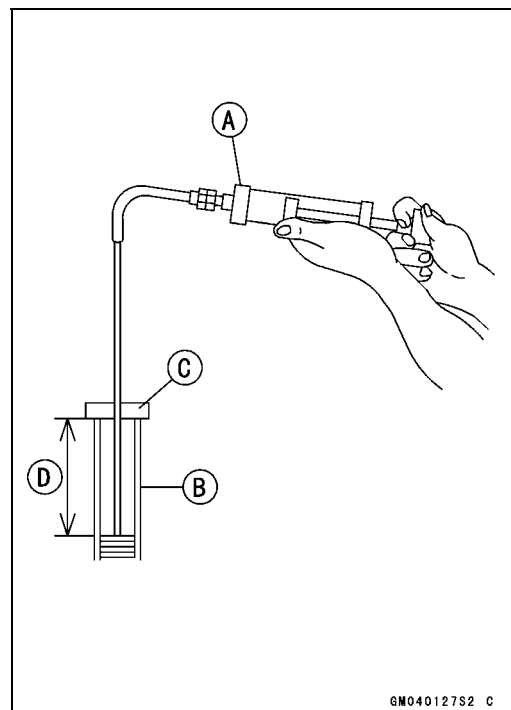
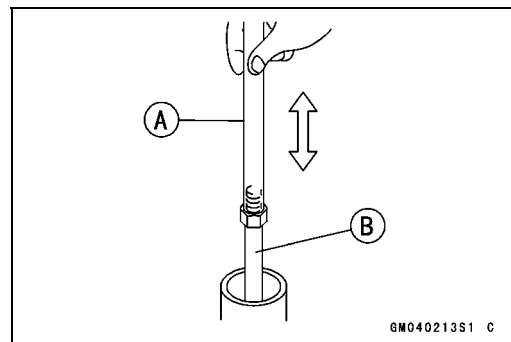

Front Fork

- Pull the piston rod [A] up above the inner tube top.
- Screw the rod nut [B] on to the piston rod with the chamfered side down.
- Check that the visible thread length is at least 11 mm (0.43 in.) [D].

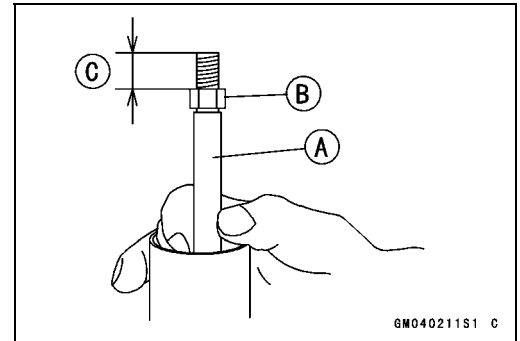

- Insert the rebound damping adjuster rod into the piston rod.
- Screw the fork piston rod puller onto the end of the rod.
Special Tool - Fork Piston Rod Puller, M12 × 1.25: 57001-1289

- Install the fork spring with the smaller end facing downward.
- Install:
 - Washer
 - Spacer
 - Washer

- Check the O-ring [A] on the top plug and replace it with a new one if damaged.
- Screw in the damper adjuster [B] of the top plug so that the distance between the adjuster bottom and the spring adjuster [C] end is 25 mm (0.98 in.) [D].

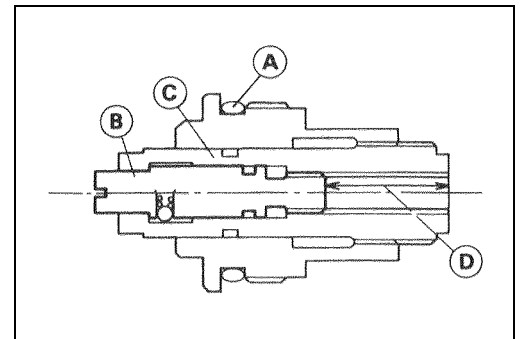

- Holding the top plug [A] with a wrench, tighten the piston rod nut [B] against the top plug.
Torque - Piston Rod Nut: 28 N·m (2.9 kgf·m, 21 ft·lb)
- Raise the outer tube and screw the top plug into it.
- Install the front fork (see Front Fork Installation).

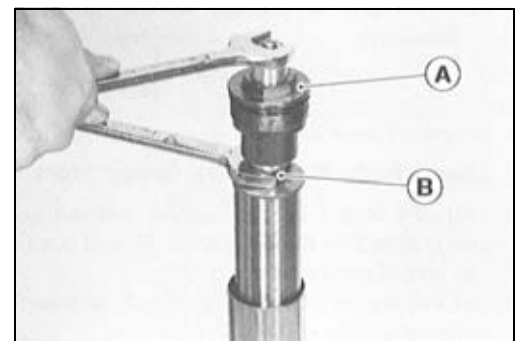

Front Fork Disassembly

- Remove the front fork (see Front Fork Removal).
- Drain the fork oil (see Fork Oil Change).
- Hold the front fork in a vise [A].
- Stop the cylinder [B] from turning by using the fork cylinder holder [C].

Special Tool - Fork Cylinder Holder, Hex 24 × □19.5: 57001-1406

- Unscrew the Allen bolt [D], then take the bolt and gasket out of the bottom of the inner tube.

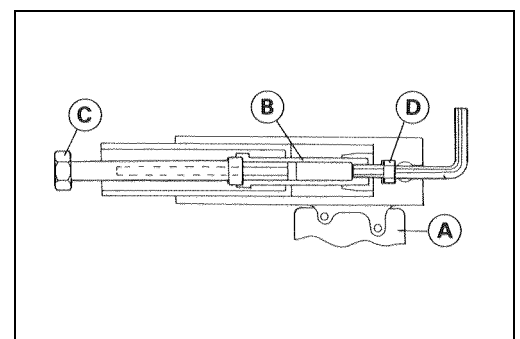

12-12 SUSPENSION

Front Fork

- Take the cylinder unit [A].
- Do not disassemble the cylinder unit.

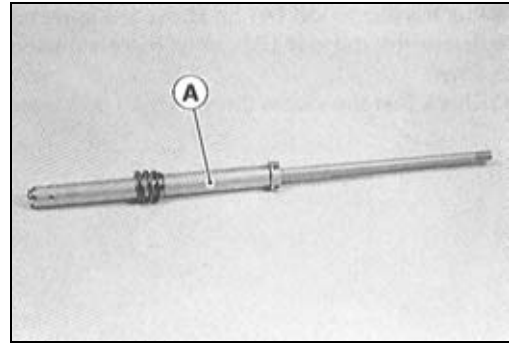

- Separate the inner tube from the outer tube as follows.
- Slide up the dust seal [A].
- Remove the retaining ring [B] from the outer tube.

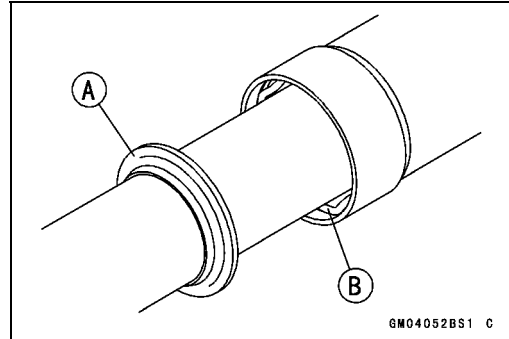

- Grasp the inner tube and stroke the outer tube up and down several times. The shock to the fork seal separates the inner tube from the outer tube.

★ If the tubes are tight, use a fork outer tube weight [A].

Special Tool - Fork Outer Tube Weight: 57001-1218

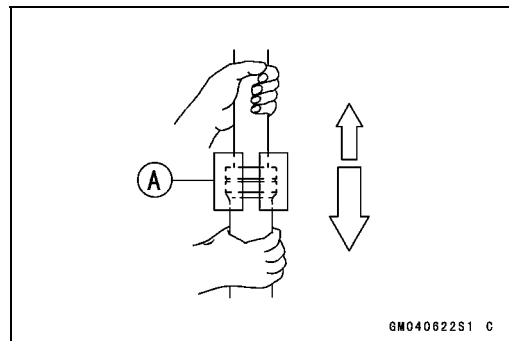

- Remove the inner tube guide bushing [A], outer tube guide bushing [B], washer [C], oil seal [D] from the inner tube.
- Remove the cylinder base from the bottom of the outer tube.

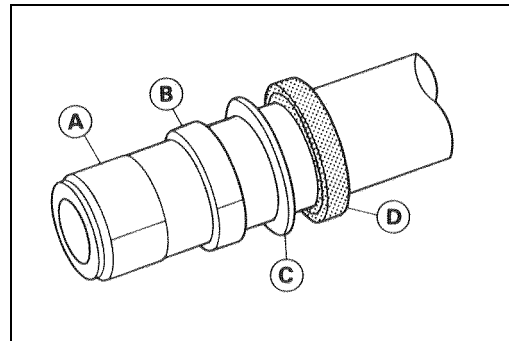

Front Fork Assembly

- Replace the following parts with new one.
 - Oil Seal
 - Guide Bushings
 - Bottom Allen Bolt Gasket
- Install the following parts onto the inner tube.
 - Dust Seal
 - Retaining Ring
 - Oil Seal
 - Washer
 - Outer Tube Guide Bushing
 - Inner Tube Guide Bushing

Front Fork

- Insert the cylinder unit [A] into the inner tube [B].
- Install the cylinder base [C] on the cylinder unit.
- Insert the inner tube, cylinder unit, cylinder base as set into the outer tube [D].
- Replace the bottom Allen bolt gasket with a new one.
- Stop the cylinder from turning by using the fork cylinder holder.

Special Tool - Fork Cylinder Holder, Hex 24 × □19.5: 57001-1406

- Apply a non-permanent locking agent to the Allen bolt and tighten it.

Torque - Front Fork Bottom Allen Bolt: 39 N·m (4.0 kgf·m, 29 ft·lb)

- Fit the new outer guide bushing [A] into the outer tube.

NOTE

○When assembling the new outer tube guide bushing, hold the used guide bushing [B] against the new bushing and tap the used guide bushing with the fork oil seal driver [C] until it stops.

Special Tool - Front Fork Oil Seal Driver: 57001-1219

- After installing the washer, install the oil seal by using the fork oil seal driver.
- Install the retaining ring and dust seal by hand.
- Pour in the specified type of oil (see Fork Oil Change).

Inner Tube, Outer Tube Inspection

- Visually inspect the inner tube, and repair any damage.
- Nick or rust damage can sometimes be repaired by using a wet-stone to remove sharp edges or raised areas which cause seal damage.
- ★ If the damage is not repairable, replace the inner tube. Since damage to the inner tube damages the oil seal, replace the oil seal whenever the inner tube is repaired or replaced.

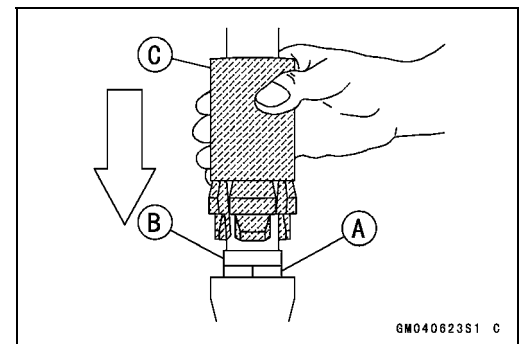
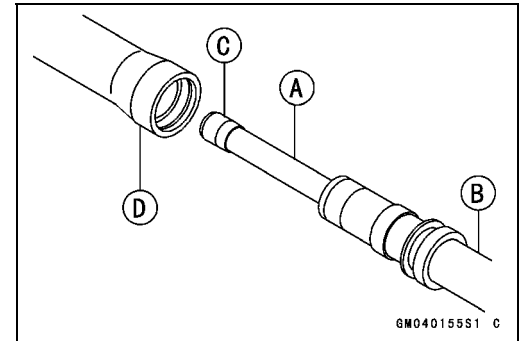

CAUTION

If the inner tube is badly bent or creased, replace it. Excessive bending, followed by subsequent straightening, can weaken the inner tube.

- Temporarily assemble the inner and outer tubes, and pump them back and forth manually to check for smooth operation.
- If you feel binding or catching, the inner and outer tubes must be replaced.

⚠ WARNING

A straightened inner or outer fork tube may fall in use, possibly causing an accident. Replace a badly bent or damaged inner or outer tube and inspect the other tube carefully before reusing it.

12-14 SUSPENSION

Front Fork

Dust Seal Inspection

- Inspect the dust seal [A] for any signs of deterioration or damage.
- ★ Replace it if necessary.

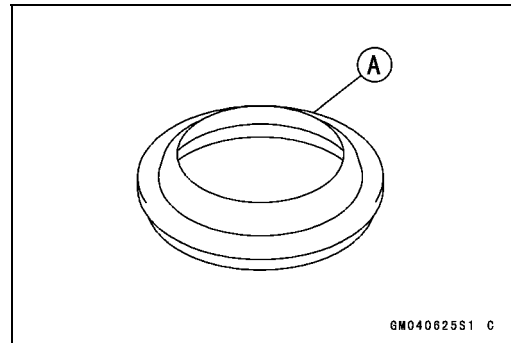

Spring Tension

- Since a spring becomes shorter as it weakens, check its free length [A] to determine its condition.
- ★ If the spring of either fork leg is shorter than the service limit, it must be replaced. If the length of a replacement spring and that of the remaining spring vary greatly, the remaining spring should also be replaced in order to keep the fork legs balanced for motorcycle stability.

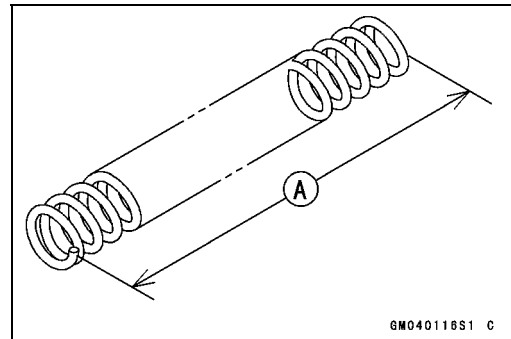

Fork Spring Free Length

Standard: 234.6 mm (9.24 in.)

Service Limit: 230 mm (9.06 in.)

Rear Shock Absorber

Rebound Damping Force Adjustment

ZX600-J1 ~ J3

- To adjust the rebound damping force, turn the lower damping adjuster [A] to the desired position, until you feel a click.
- The standard adjuster setting for an average-build rider of 68 kg (150 lb) with no passenger and no accessories is the **10th click** from the 1st click of the fully clockwise position.

ZX600-J4 ~ (US), ZX600J6F ~ (CA)

- To adjust the rebound damping force, turn the lower damping adjuster [A] to the desired position up to the specified turns.
- The standard adjuster setting for an average-build rider of 68 kg (150 lb) and with no passenger and no accessories is 2 1/2 turns out from fully clockwise position.

Rebound Damping Force Adjustment

Adjuster Position	Damping Force	Setting	Load	Road	Speed
A	Weak	Soft	Light	Good	Low
↑	↑	↑	↑	↑	↑
↓	↓	↓	↓	↓	↓
B	Strong	Hard	Heavy	Bad	High

- A: 18 clicks (ZX600-J1 ~ J3)
4 1/2 turns out (ZX600-J4 ~ (US), ZX600J6F ~ (CA))
- B: 1 click (ZX600-J1 ~ J3)
Fully clockwise position (ZX600-J4 ~ (US), ZX600J6F ~ (CA))

Compression Damping Force Adjustment

ZX600-J1 ~ J3

- To adjust the compression damping force, turn the upper damping adjuster [A] to the desired position until you feel a click.
- The standard adjuster setting for the average-build rider of 68 kg (150 lb) with no passenger and no accessories is the **10th click** from the 1st click of the fully clockwise position.

ZX600-J4 ~ (US), ZX600J6F ~ (CA)

- To adjust the compression damping force, turn the upper damping adjuster [A] to the desired position up to the specified turns.
- The standard adjuster setting for an average-build rider of 68 kg (150 lb) and with no passenger and no accessories is 2 1/2 turns out from fully clockwise position.

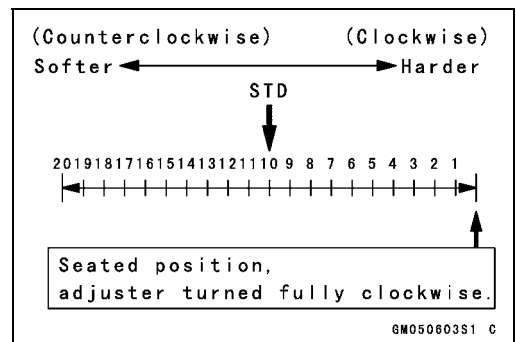
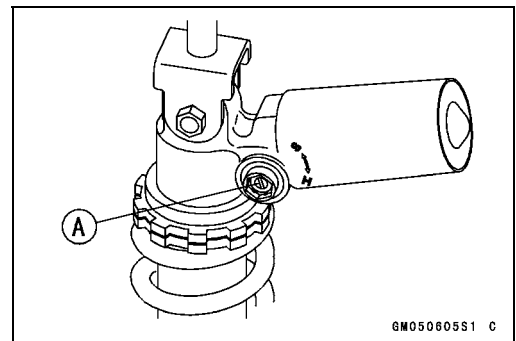
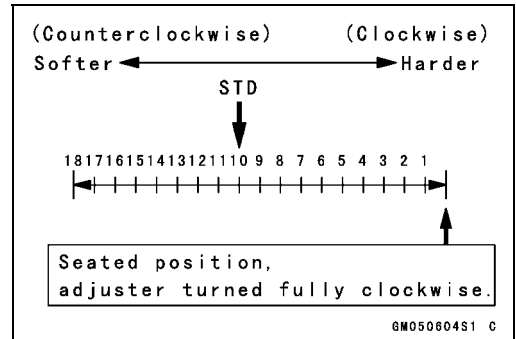
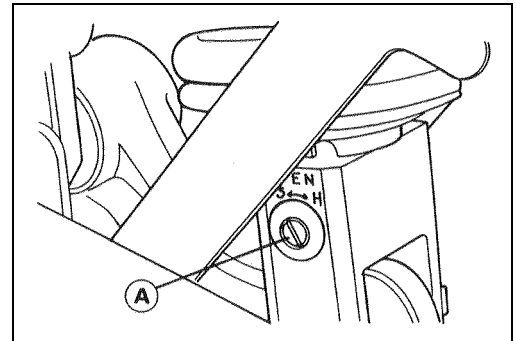

12-16 SUSPENSION

Rear Shock Absorber

Compression Damping Force Adjustment

Adjuster Position	Damping Force	Setting	Load	Road	Speed
A	Weak	Soft	Light	Good	Low
↑	↑	↑	↑	↑	↑
↓	↓	↓	↓	↓	↓
B	Strong	Hard	Heavy	Bad	High

A: 20 clicks (ZX600-J1 ~ J3)

5 turns out (ZX600-J4 ~ (US), ZX600J6F ~ (CA))

B: 1 click (ZX600-J1 ~ J3)

Fully clockwise position (ZX600-J4 ~ (US), ZX600J6F ~ (CA))

Spring Preload Adjustment

- Remove the rear shock absorber from the frame (see Rear Shock Absorber Removal).
- Loosen the locknut and turn out the adjusting nut to free the spring.

Special Tool - Hook Wrench: 57001-1101

- To adjust the spring preload, turn in the adjusting nut [A] to the desired position and tighten the locknut [B].
- [C] Spring Length

Spring Preload Setting

Standard: Spring length 180 mm (7.09 in.)

Usable Range: Spring length 182 mm (7.17 in.) to 170 mm (6.69 in.)

- The standard adjusting nut setting for an average-build rider of 68 kg (150 lb) with no passenger and no accessories is 180 mm (7.09 in.) spring length.

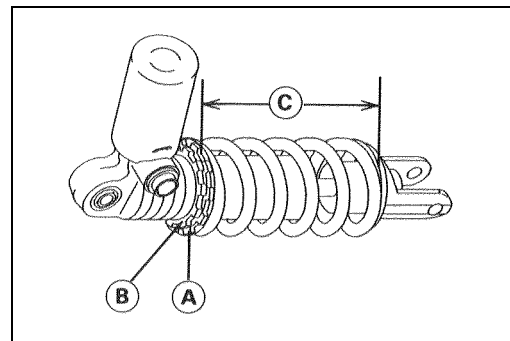

Spring Adjustment

Adjuster Position	Damping Force	Setting	Load	Road	Speed
182 mm (7.17 in.)	Weak	Soft	Light	Good	Low
↑	↑	↑	↑	↑	↑
↓	↓	↓	↓	↓	↓
170 mm (6.69 in.)	Strong	Hard	Heavy	Bad	High

Rear Shock Absorber Removal

- Remove the lower fairings (see Frame chapter).
- Using the jack, raise the rear wheel off the ground.

Special Tool - Jack: 57001-1238

- Squeeze the brake lever slowly and it with a band [A].

⚠ WARNING

Be sure to hold the front brake when removing the shock absorber, or the motorcycle may fall over. It could cause an accident and injury.

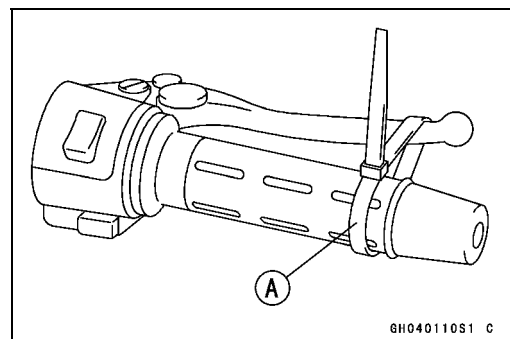

6H040110S1 C

Rear Shock Absorber

- Remove:
 - Lower Shock Absorber Bolt [A]
 - Upper Tie-Rod Bolt [B]

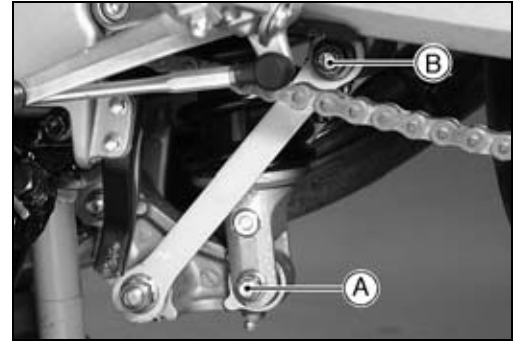

- Remove:
 - Upper Shock Absorber Nut [A]
 - Upper Shock Absorber Bolt [B]
- Remove the shock absorber forward the ground.

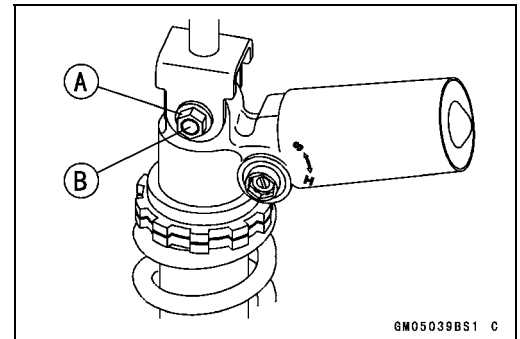

Rear Shock Absorber Installation

- Pack the rocker arm needle bearings with grease.
- Tighten:
 - Torque - Rear Shock Absorber Nuts: 34 N·m (3.5 kgf·m, 25 ft·lb)
 - Tie-Rod Nuts: 59 N·m (6.0 kgf·m, 43 ft·lb)

Rear Shock Absorber Inspection

- Remove the rear shock absorber.
- Visually inspect the following items.
 - Smooth Stroke
 - Oil Leakage
 - Crack or Dent
- ★ If there is any damage to the rear shock absorber, replace it.
- Visually inspect the rubber bushing.
- ★ If it show any signs of damage, replace it.

Rear Shock Absorber Scrapping

⚠ WARNING

Since the reservoir tank of the rear shock absorber contains nitrogen gas, do not incinerate the reservoir tank without first releasing the gas or it may explode.

- Remove the valve cap [A] and release the nitrogen gas completely from the gas reservoir.
- Remove the valve.

⚠ WARNING

Since the high pressure gas is dangerous, do not point the valve toward your face or body.

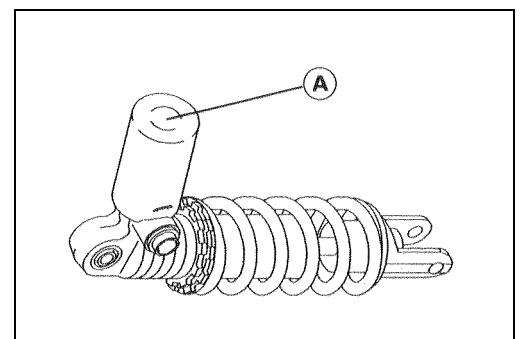

12-18 SUSPENSION

Swingarm

Swingarm Removal

- Remove:
 - Rear Wheel (see Wheels/Tires chapter)
 - Chain Cover (see Final Drive chapter)
 - Brake Hose Clamp [A]
 - Lower Shock Absorber Nut and Bolt [B]
 - Upper Tie-Rod Nut and Bolt [C]
 - Swingarm Pivot Nut [D]
- Pull off the pivot shaft and remove the swingarm.

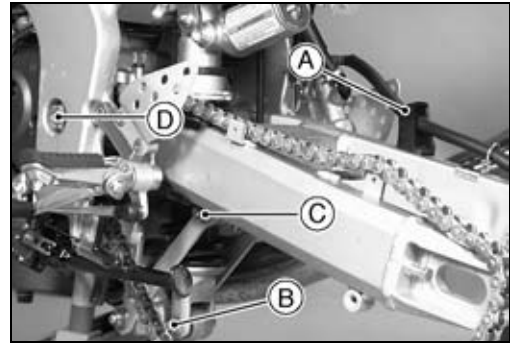

Swingarm Installation

- Apply plenty of grease to the ball bearing, needle bearings and grease seals, and add plenty grease to the grease nipple.
- Install the collars [A] and cap [B].
- Insert the pivot shaft into the frame from the right side.
- Tighten:
 - Torque - Swingarm Pivot Nut: 108 N·m (11 kgf·m, 80 ft·lb)

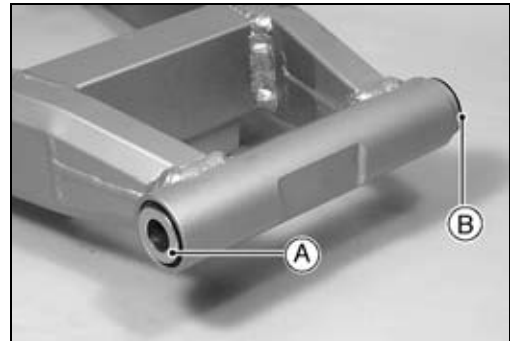

Swingarm Bearing Removal

- Remove:
 - Swingarm
 - Collars [A]
 - Cap [B]
 - Grease Seals [C]
 - Sleeve [D]
 - Circlip (right side) [E]
- Special Tool - Inside Circlip Pliers: 57001-143

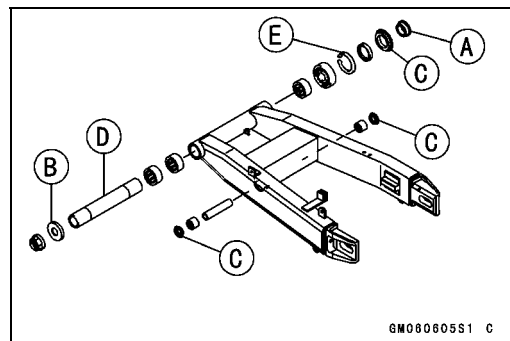

- Remove the ball bearing and needle bearings.
 - Special Tool - Oil Seal & Bearing Remover: 57001-1058 [A]

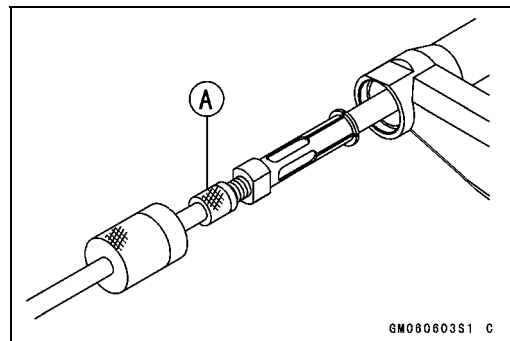

Swingarm Bearing Installation

- Apply plenty of grease to the ball bearing and needle bearings.
- Install the needle bearings so that the manufacturer's marks faces in.
- Install the ball bearing so that the manufacturer's marks faces out.
- Special Tool - Bearing Driver Set: 57001-1129 [A]

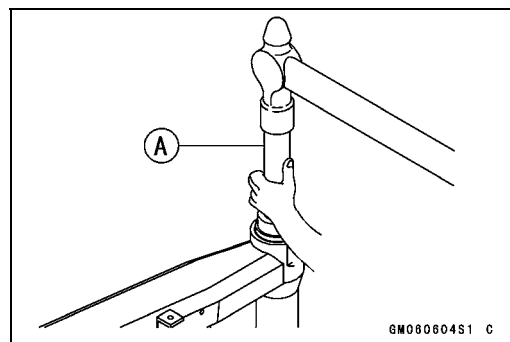

Swingarm

Swingarm Bearing, Sleeve Inspection

CAUTION

Do not remove the bearings for inspection. Remove may damage them.

- Check the ball bearing.
- Since the ball bearing is made to extremely close tolerances, the wear must be judged by feel rather than measurement.
- Turn [A] the bearing in the swingarm back and forth while checking for plays, roughness, or binding.
- ★ If bearing play, roughness, or binding is found, replace the bearing.
- The rollers in a needle bearing normally wear very little, and wear is difficult to measure. Instead of measuring, inspect the bearing in the swingarm for abrasion, color change, or other damage.
- ★ If there is any doubt as to the condition of any of the needle bearings or sleeve, replace the sleeve, and needle bearings as a set.

Swingarm Lubrication

- Apply grease to the inner surfaces of the needle bearings in accordance with the Periodic Maintenance Chart.
- Apply a thin coat of grease to the lips of the grease seals.

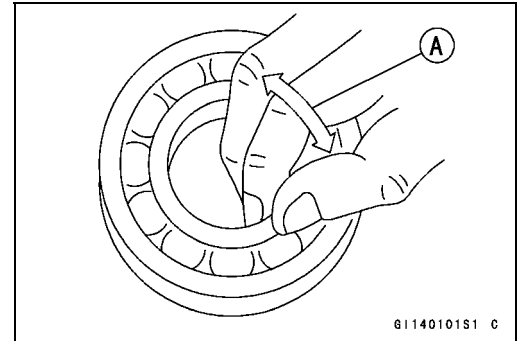

12-20 SUSPENSION

Tie-Rod, Rocker Arm

Tie-Rod Removal

- Remove:
 - Upper and Lower Fairings (see Frame chapter)
 - Radiator (see Cooling System chapter)
 - Muffler (see Engine Top End chapter)
- Squeeze the brake lever slowly and hold it with a band [A].

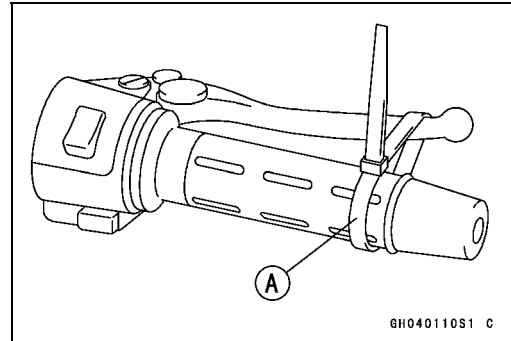

- Using the jack, raise the rear wheel off the ground.

Special Tool - Jack: 57001-1238

- Remove:
 - Upper Tie-Rod Bolt and Nut [A]
 - Lower Tie-Rod Bolt and Nut [B]
 - Tie-Rods [C]

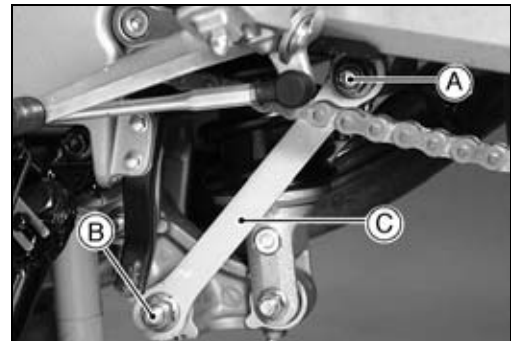

Tie-Rod Installation

- Apply grease to the inside of the needle bearings and grease seals.
- Install the tie-rods so that the chamfered side faces the bolts and nuts.
- Tighten:
 - Torque - Tie-Rod Nuts: 59 N·m (6.0 kgf·m, 43 ft·lb)**

Rocker Arm Removal

- Remove:
 - Upper and Lower Fairings (see Frame chapter)
 - Radiator (see Cooling System chapter)
 - Muffler (see Engine Top End chapter)
 - Squeeze the brake lever slowly and hold it with a band.
 - Using the jack, raise the rear wheel off the ground.
- Special Tool - Jack: 57001-1238**
- Remove:
 - Lower Rear Shock Absorber Bolt and Nut [A]
 - Lower Tie-Rod Bolt and Nut [B]
 - Rocker Arm Bolt and Nut [C]
 - Rocker Arm [D]

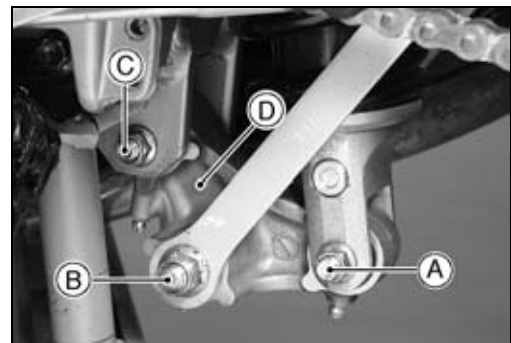

Rocker Arm Installation

- Apply grease to the inside of the needle bearings grease seals.
- Add grease to the grease nipple (ZX600-J1 ~ J3).
- Tighten:
 - Torque - Rocker Arm Nut: 34 N·m (3.5 kgf·m, 25 ft·lb)**
 - Tie-Rod Nut: 59 N·m (6.0 kgf·m, 43 ft·lb)**
 - Rear Shock Absorber Nut: 34 N·m (3.5 kgf·m, 25 ft·lb)**

Tie-Rod, Rocker Arm

*Rocker Arm/Tie-Rod Bearing, Sleeve Inspection***CAUTION**

Do not remove the bearings for inspection. Remove may damage them.

- Visually inspect the swingarm sleeves and needle bearings.
- The rollers in a needle bearing normally wear very little, and wear is difficult to measure. Instead of measuring, inspect the bearing for abrasion, color change, or other damage.
- ★ If there is any doubt as to the condition of any of the needle bearings or sleeve, replace the sleeve, and needle bearings as a set.

Rocker Arm/Tie-Rod Lubrication

- Apply grease to the inner surfaces of the needle bearings in accordance with the Periodic Maintenance Chart.
- Apply a thin coat of grease to the lips of the grease seals.

Steering

Table of Contents

Exploded View	13-2
Specifications	13-3
Steering	13-4
Steering Inspection	13-4
Steering Adjustment.....	13-4
Steering Stem.....	13-5
Steering Stem, Stem Bearing Removal	13-5
Steering Stem, Stem Bearing Installation	13-5
Steering Stem Bearing Lubrication	13-7
Steering Stem Warp Inspection	13-7
Handlebar	13-8
Handlebar Removal	13-8
Handlebar Installation	13-8
Handlebar Holder Removal.....	13-8
Handlebar Holder Installation.....	13-9

13-2 STEERING

Exploded View

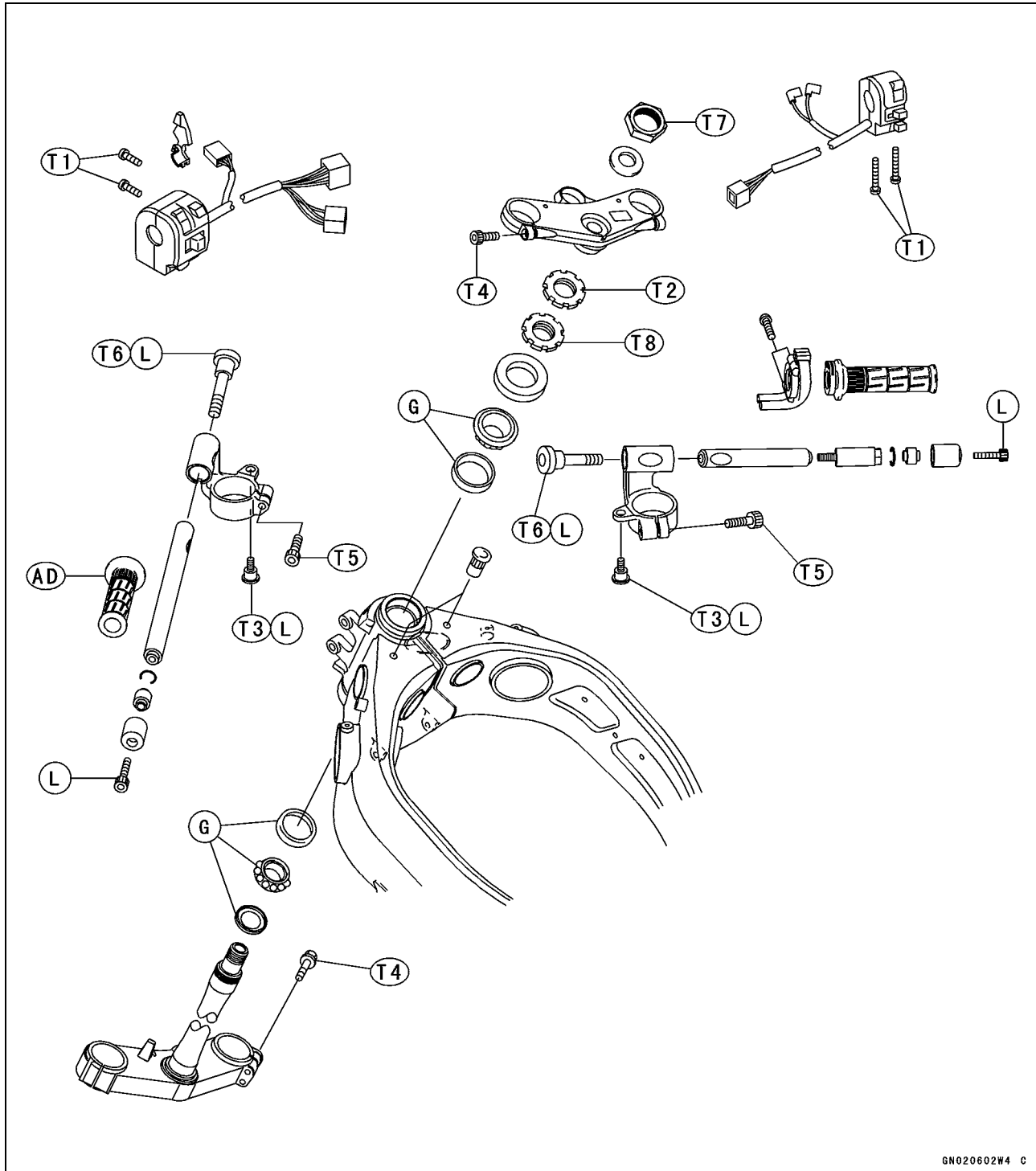

GN020602W4 C

T1: 3.5 N·m (0.35 kgf·m, 30 in·lb)

T2: 4.9 N·m (0.5 kgf·m, 36 in·lb)

T3: 9.8 N·m (1.0 kgf·m, 87 in·lb)

T4: 20 N·m (2.0 kgf·m, 14.5 ft·lb)

T5: 25 N·m (2.5 kgf·m, 18 ft·lb)

T6: 34 N·m (3.5 kgf·m, 25 ft·lb)

T7: 49 N·m (5.0 kgf·m, 36 ft·lb)

T8: 15 N·m (1.5 kgf·m, 11 ft·lb)

AD: Apply adhesive.

G: Apply grease.

L: Apply a non-permanent locking agent.

Specifications

Special Tools - Steering Stem Nut Wrench: 57001-1100
Head Pipe Outer Race Press Shaft: 57001-1075
Head Pipe Outer Race Driver, ϕ 55: 57001-1446
Head Pipe Outer Race Driver, ϕ 47: 57001-1447
Steering Stem Bearing Driver, ϕ 42.5: 57001-1344
Steering Stem Bearing Driver Adapter, ϕ 41.5: 57001-1345
Jack: 57001-1238

13-4 STEERING

Steering

Steering Inspection

- Lift the front wheel off the ground using the jack.
 - Special Tool - Jack: 57001-1238**
- With the front wheel pointing straight ahead, alternately tap each end of the handlebar. The front wheel should swing fully left and right from the force of gravity until the fork hits the stop.
- ★ If the wheel binds or catches before the stop, the steering is too tight.
- Feel for steering looseness by pushing and pulling the forks.
- ★ If you feel looseness, the steering is too loose.

NOTE

- The cables and wiring will have some effect on the motion of the fork which must be taken into account.
- Be sure the wires and cables are properly routed.
- The bearings must be in good condition and properly lubricated in order for any test to be valid.

Steering Adjustment

- Remove:
 - Upper fairing (see Frame chapter)
 - Fuel Tank (see Fuel System chapter)
 - Rear View Mirror Bracket
- Loosen:
 - Lower Fork Clamp Bolts (both sides)
 - Stem Head Nut [A]
- Adjust the steering.
 - Special Tool - Steering Stem Nut Wrench: 57001-1100 [B]**
- ★ If the steering is too tight, loosen the stem nut a fraction of a turn.
- ★ If the steering is too loose, tighten the stem nut a fraction of a turn.

NOTE

- Turn the stem nut 1/8 turn at a time maximum.
- Tighten:
 - Torque - Steering Stem Head Nut: 49 N·m (5.0 kgf·m, 36 ft·lb)**
 - Front Fork Clamp Bolts (Lower): 20 N·m (2.0 kgf·m, 14.5 ft·lb)**
- Check the steering again.
- ★ If the steering is still too tight or too loose, repeat the adjustment.

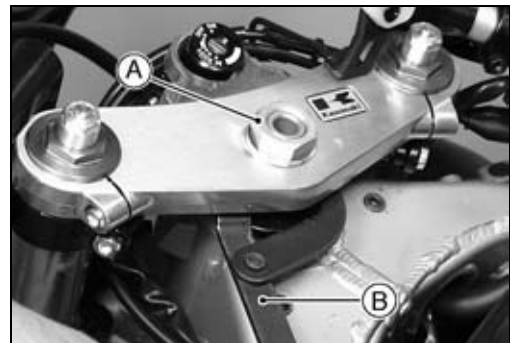

Steering Stem

Steering Stem, Stem Bearing Removal

- Remove:
 - Fairings (see Frame chapter)
 - Fuel Tank (see Fuel System chapter)
 - Rear View Mirror Bracket
 - Brake Hose Joint Bolt [A] and Bracket Bolt [A]
 - Front Wheel (see Wheels/Tires chapter)
 - Front Fork (see Suspension chapter)
 - Steering Stem Head Nut and Washer
 - Steering Stem Head and Handlebars
- Pushing up the stem base, and remove the steering stem lock nut [A], steering stem nut [B], stem cap [C], then remove the steering stem [D].

Special Tool - Steering Stem Nut Wrench: 57001-1100

- Remove the upper ball bearing inner race.

- To remove the bearing outer races [A] pressed into the head pipe [B], insert a bar [C] into the recesses [D] of head pipe and applying it to both recess alternately hammer it to drive the race out.

NOTE

If either steering stem bearing is damaged, it is recommended that both the upper and lower bearings (including outer races) should be replaced with new ones.

- Remove the lower bearing inner race (with its grease seal) which is pressed onto the steering stem with a suitable commercially available bearing puller.

Steering Stem, Stem Bearing Installation

- Replace the bearing outer races with new ones.
- Apply grease to the outer races, and drive them into the head pipe at the same time.

- Special Tools - Head Pipe Outer Race Press Shaft: 57001-1075 [A]**
Head Pipe Outer Race Driver, ϕ 55: 57001-1446 [B]
Head Pipe Outer Race Driver, ϕ 47: 57001-1447 [C]

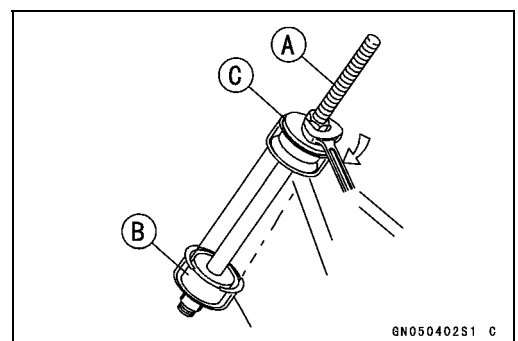
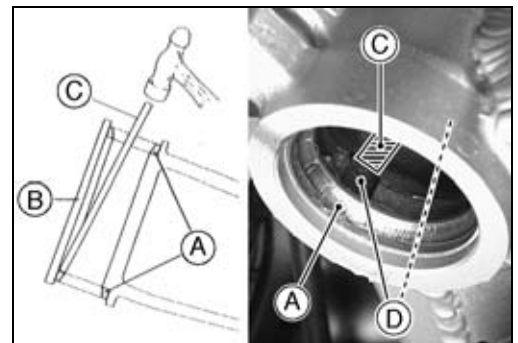
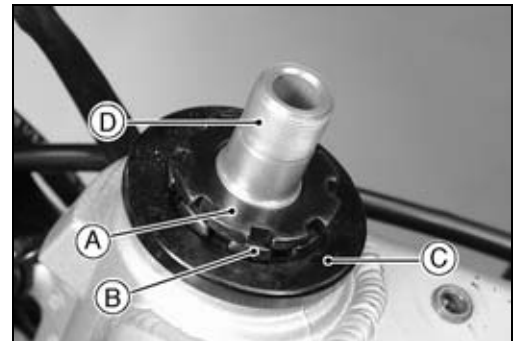

6N050402S1 C

13-6 STEERING

Steering Stem

- Replace the bearing inner races with new ones.
- Install the oil seal [D] on the steering stem, and drive the lower ball bearing inner race [A] applied the grease onto the stem.

Special Tools - Steering Stem Bearing Driver, $\phi 42.5$: 57001-1344 [B]

Steering Stem Bearing Driver Adapter, $\phi 41.5$: 57001-1345 [C]

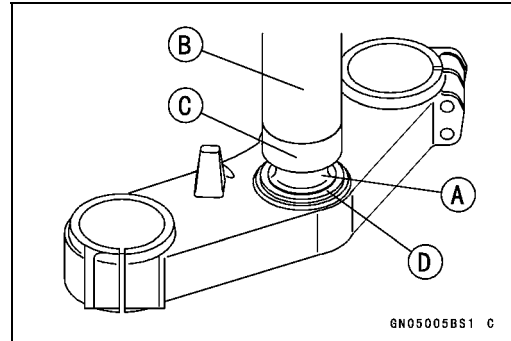

- Install the lower ball bearing [A] onto the stem.
- Apply grease to the upper ball bearing [B] and inner race [C].
- Install the stem through the head pipe and install the ball bearing and inner race on it.

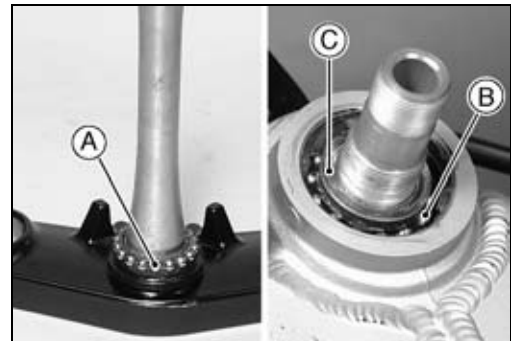

- Install stem cap [A] and steering stem nut [B] and hand tighten it and steering stem lock nut [C].
- Install the stem head.
- Install the washer [D], and tighten the stem head nut [E] lightly.

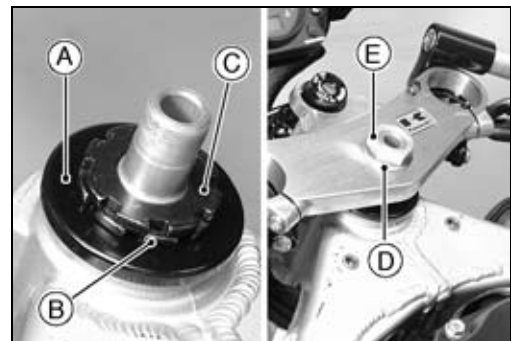

- Settle the bearings in place as follows:
 - Tighten the steering stem nut with 15 N·m (1.5 kgf·m, 11 ft·lb) of torque first, and loosen it a fraction of a turn until it turns lightly. (To tighten the stem nut to the specified torque, hook the wrench on the stem nut, and pull the wrench at the hole by 84 N (8.3 kg) [B] force in the direction shown.) Afterward tighten it again with specified torque using a special tool [A].
 - Tighten the steering stem lock nut with specified torque using a special tool [A].
 - Check that there is no play and the steering stem turns smoothly without rattles. If not, the steering stem bearing may be damaged.
 - Again back out the stem lock nut a fraction of turn until it turns lightly.
- Turn the stem lock nut lightly clockwise until it just becomes hard to turn. Do not overtighten, or the steering will be too tight.

Special Tool - Steering Stem Nut Wrench: 57001-1100 [A]

Torque - Steering Stem Nut: 15 N·m (1.5 kgf·m, 11 ft·lb)

Steering Stem Lock Nut: 4.9 N·m (0.5 kgf·m, 43 in·lb)

- Install the front fork (see Suspension chapter).

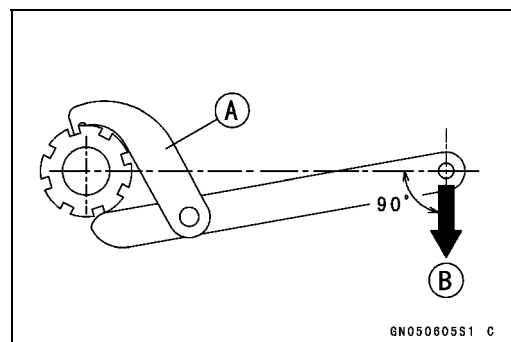

Steering Stem

NOTE

○Tighten the fork upper clamp bolts first, next the stem head nut, last the fork lower clamp bolts.

Torque - Steering Stem Head Nut: 49 N·m (5.0 kgf·m, 36 ft·lb)

Front Fork Clamp Bolts (Upper): 20 N·m (2.0 kgf·m, 14.5 ft·lb)

Front Fork Clamp Bolts (Lower): 20 N·m (2.0 kgf·m, 14.5 ft·lb)

⚠ WARNING

Do not impede the handlebar turning by routing the cables, harnesses and hoses improperly (see General Information chapter).

Steering Stem Bearing Lubrication

- Remove the steering stem.
- Using a high flash-point solvent, wash the upper and lower ball bearings in the cages, and wipe the upper and lower outer races, which are press-fitted into the frame head pipe, clean off grease and dirt.
- Visually check the outer races and the ball bearings.
- ★ Replace the bearing assemblies if they show wear or damage.
- Pack the upper and lower ball bearings [A] in the cages with grease, and apply a light coat of grease to the upper and lower outer races.
- Install the steering stem, and adjust the steering.

Steering Stem Warp Inspection

- Whenever the steering stem is removed, or if the steering can not be adjusted for smooth action, check the steering stem for straightness.
- ★ If the steering stem [A] is bent, replace the steering stem.

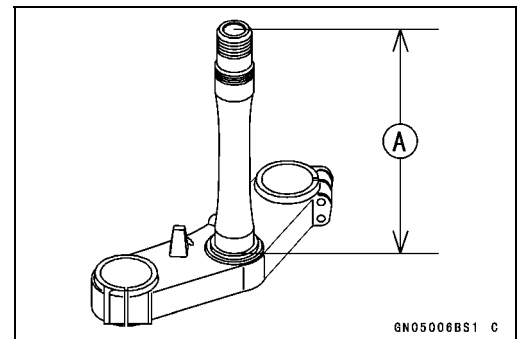
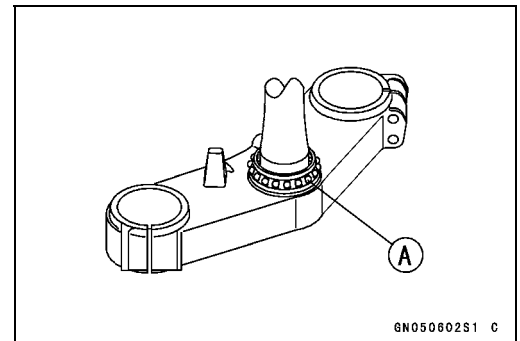

13-8 STEERING

Handlebar

Handlebar Removal

- Remove:
 - Screws [A] and Windshield [B]

- Remove:
 - Clutch Lever Assembly
 - Left Handlebar Switch Housing
 - Front Brake Master Cylinder
 - Right Handlebar Switch Housing
 - Throttle Case and Grip
- Remove the handlebar bolts [A], and then pull out the handlebars [B].

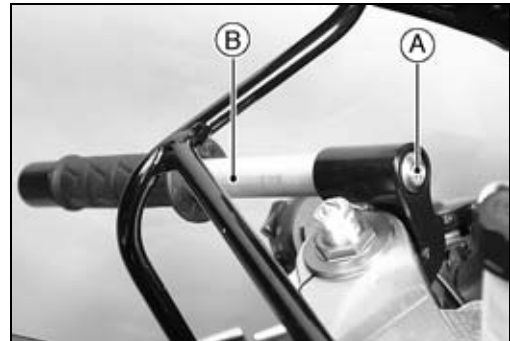
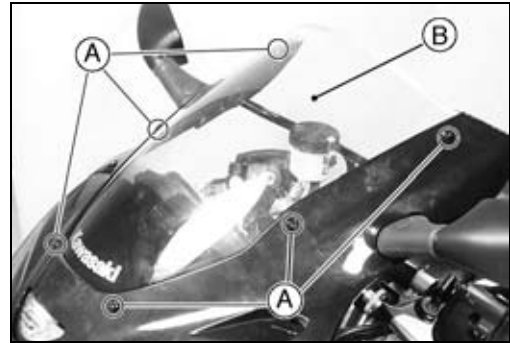

Handlebar Installation

- Fit the pin [A] of the handlebar in the handlebar holder recess [B].
- Apply a non-permanent locking agent to the threads of handlebar bolts, and tighten the bolts.
- **Torque - Handlebar Bolts: 34 N·m (3.5 kgf·m, 25 ft·lb)**
- Install the removed parts (see appropriate chapters).

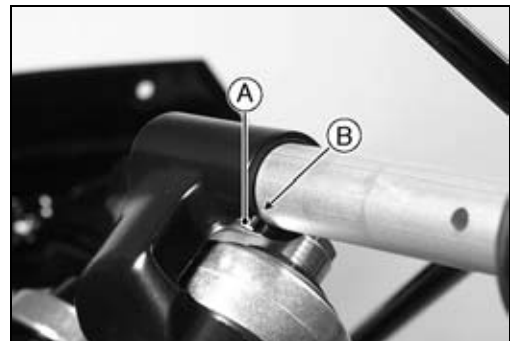

Handlebar Holder Removal

- Raise the front wheel off the ground.
 - Loosen the handlebar holder bolts [A] and upper fork clamp bolts [B].
 - Remove stem head nut [C] and steering stem head [D].
-
- Remove handlebar holder position bolts [A] and handlebar holders [B].

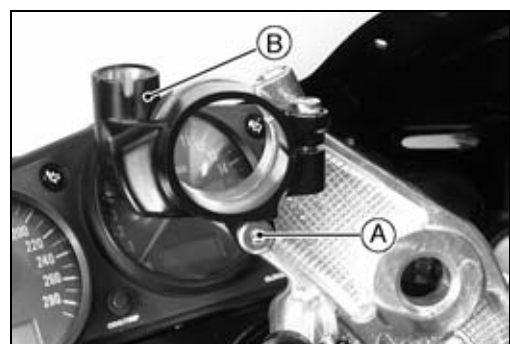
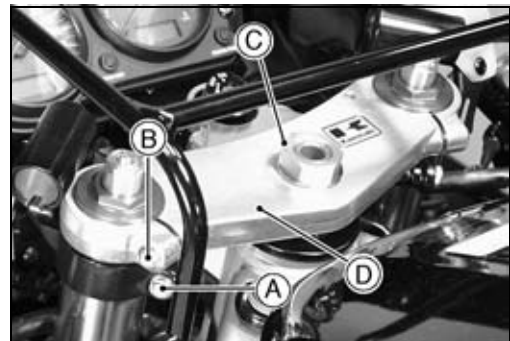

Handlebar

Handlebar Holder Installation

- Apply a non-permanent locking agent to the thread of handlebar position bolts and tighten them.

Torque - Handlebar Holder Position Bolts: 9.8 N·m (1.0 kgf·m, 87 in·lb)

- Install the remove parts (see appropriate chapters).
- Tighten:

Torque - Steering Stem Head Nut: 49 N·m (5.0 kgf·m, 36 ft·lb)

Handlebar Holder Bolts: 25 N·m (2.5 kgf·m, 18 ft·lb)

Upper Fork Clamp Bolts: 20 N·m (2.0 kgf·m, 14.5 ft·lb)

Frame

Table of Contents

Exploded View	14-2
Seats	14-5
Rear Seat Removal.....	14-5
Rear Seat Installation.....	14-5
Front Seat Removal	14-5
Front Seat Installation	14-5
Fairings.....	14-6
Lower Fairing Removal	14-6
Inner (Upper) Fairing Removal	14-6
Inner (Lower) Fairing Removal	14-6
Upper Fairing Removal	14-6
Seat Covers.....	14-8
Seat Cover Removal.....	14-8
Seat Cover Installation.....	14-8
Fenders	14-9
Front Fender Removal	14-9
Rear Fender Removal.....	14-9
Frame	14-10
Rear Frame Removal.....	14-10
Rear Frame Installation.....	14-10
Frame Inspection	14-10

14-2 FRAME

Exploded View

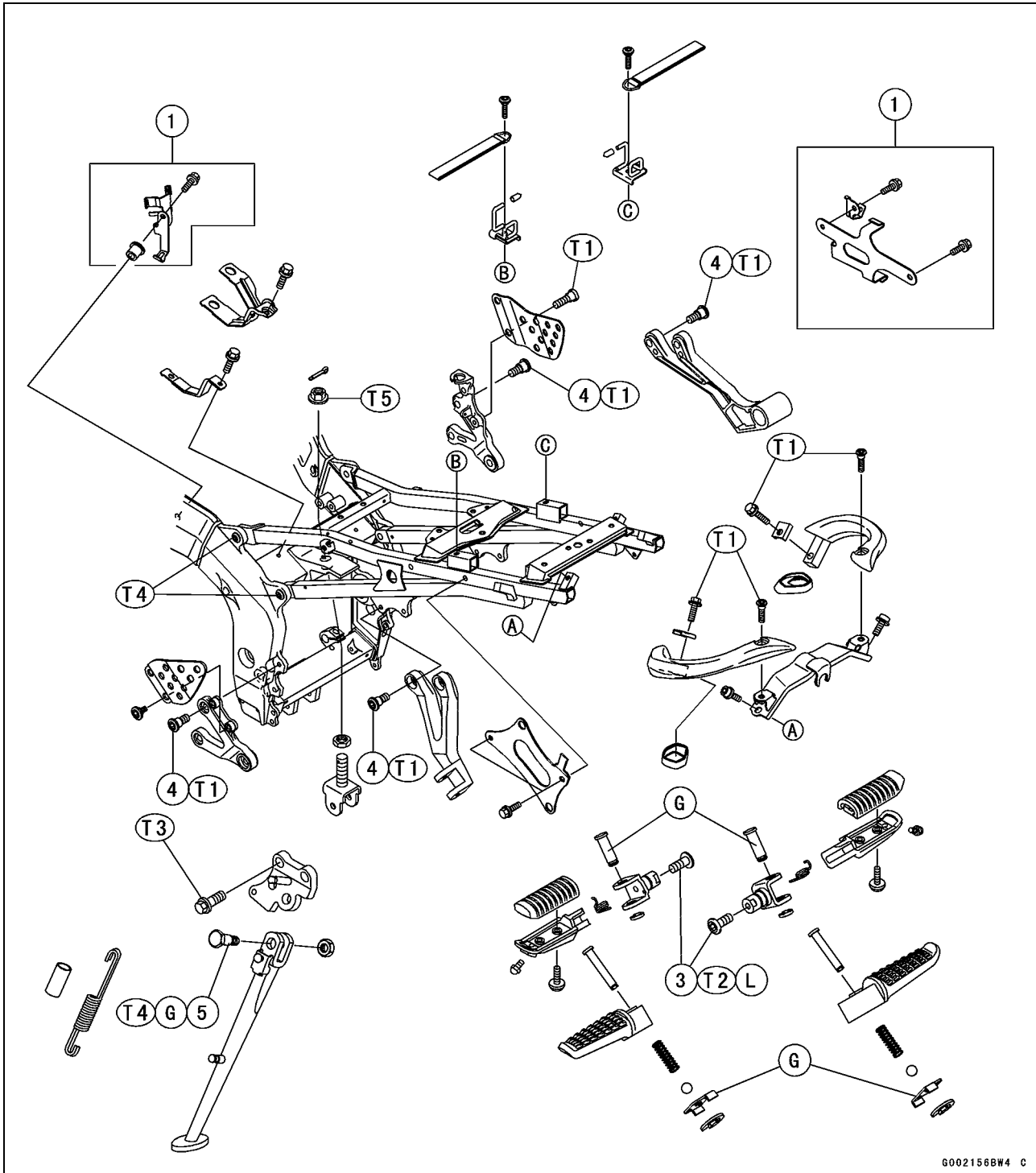

G002156BW4 C

- 1. California Model
- 2. Front Fender Mounting Bolts
- 3. Footpeg Mounting Bolts
- 4. Footpeg Bracket Mounting Bolts
- 5. Sidestand Mounting Bolt
- T1: 25 N·m (2.5 kgf·m, 18 ft·lb)
- T2: 34 N·m (3.5 kgf·m, 25 ft·lb)
- T3: 49 N·m (5.0 kgf·m, 36 ft·lb)
- T4: 44 N·m (4.5 kgf·m, 33 ft·lb)
- T5: 59 N·m (6.0 kgf·m, 43 ft·lb)
- G: Apply grease.
- L: Apply a non-permanent locking agent

Exploded View

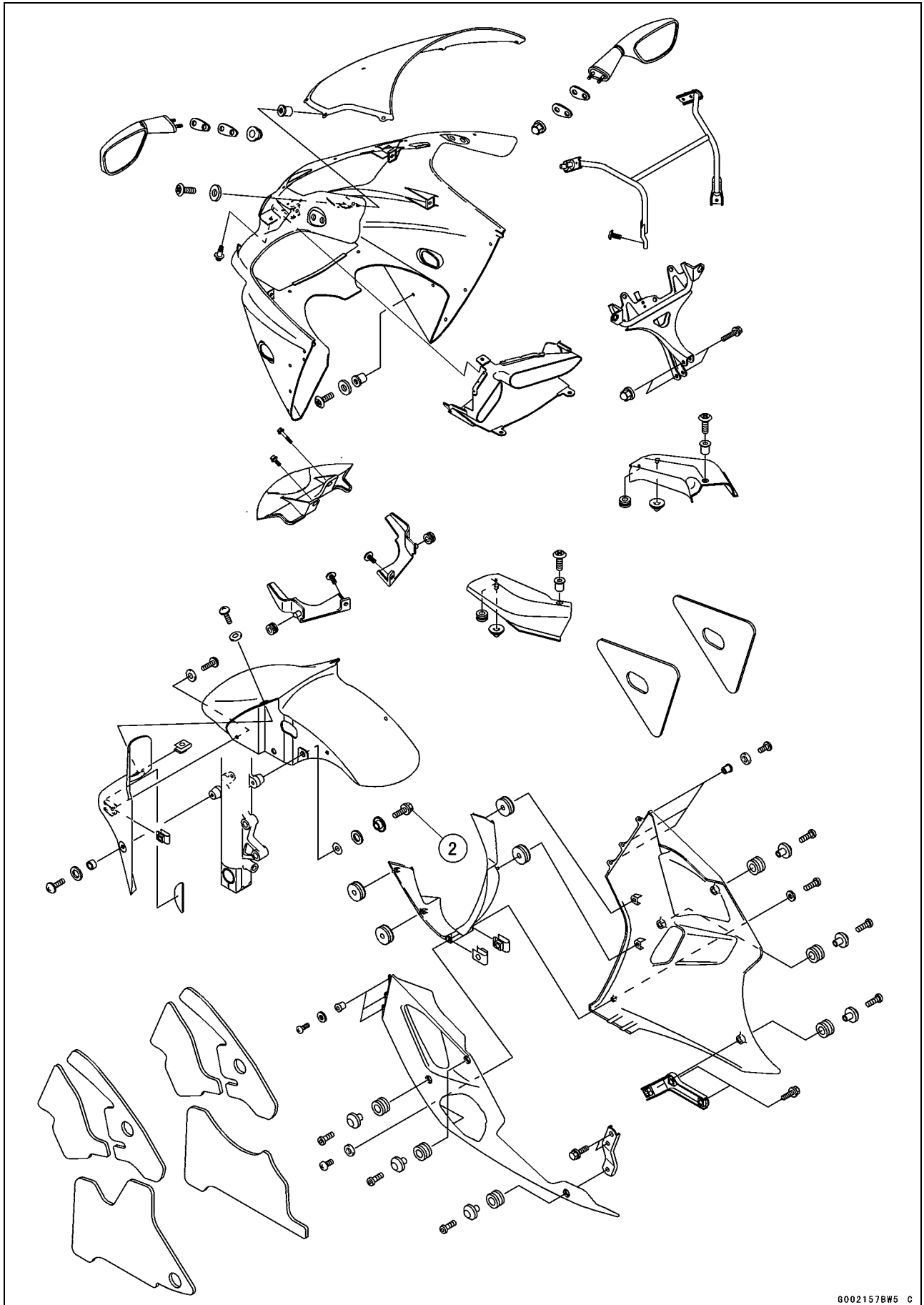

14-4 FRAME

Exploded View

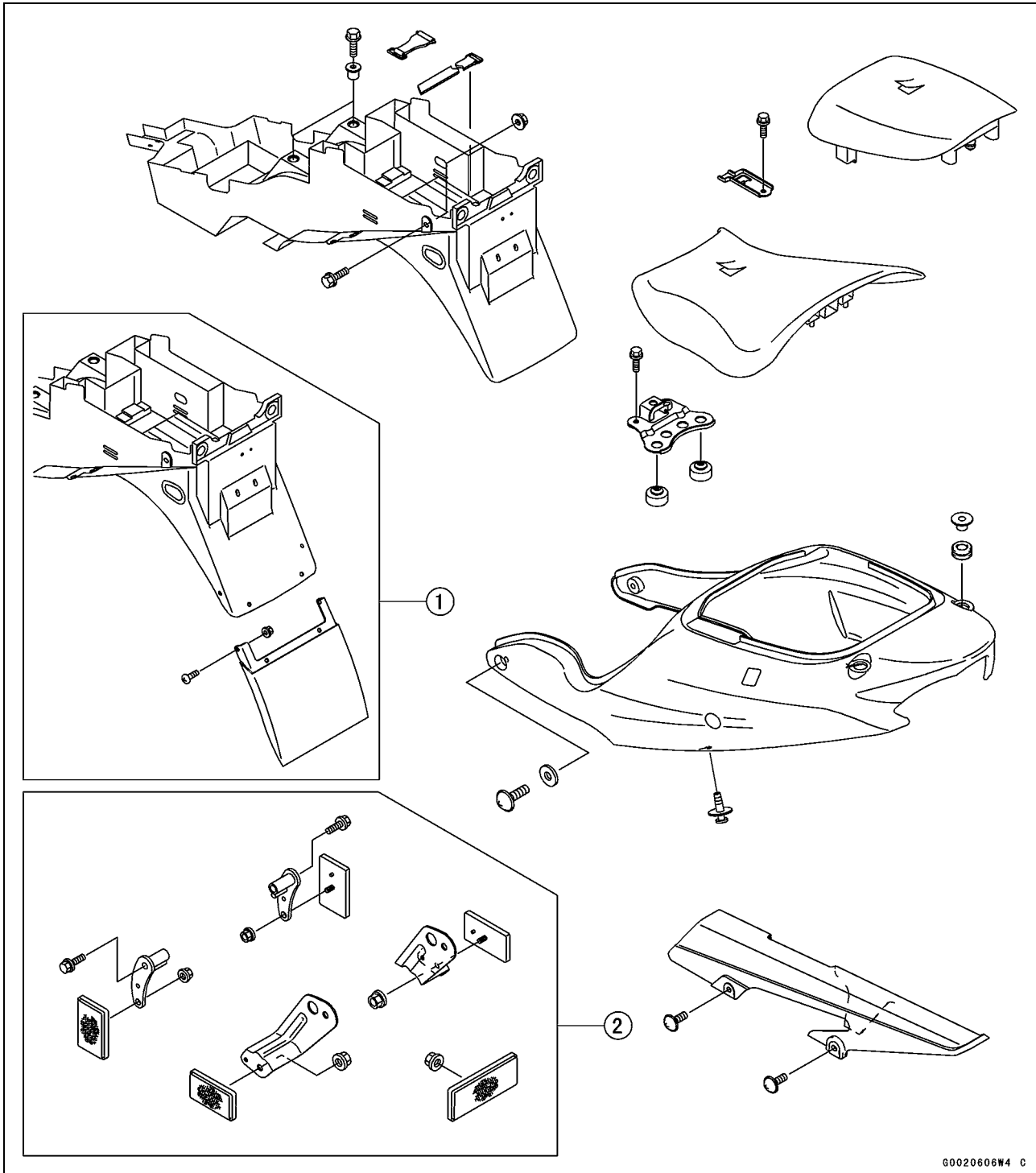

1. PN Model

2. United States , Canada Models

PN: WVTA Approval Model with Pipe Catalytic Converter (Norway)

Seats

Rear Seat Removal

- Insert the ignition switch key into the seat lock [A], turning the key counterclockwise, pulling up the rear of the seat [B], and pulling the seat backward.



Rear Seat Installation

- Slip the rear seat hooks [A] into the hollow-cubic bracket [B] on the frame.
- Insert the seat pin [C] into the latch hole [D].
- Push down the rear part of the seat until the lock clicks.

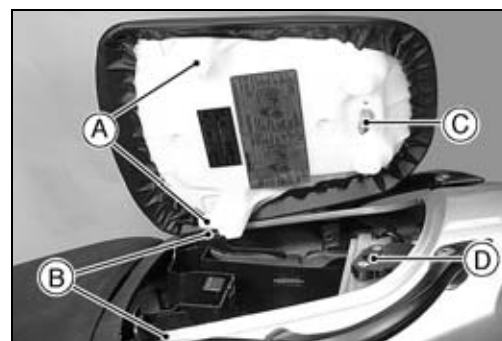

Front Seat Removal

- Remove:
 - Rear Seat (see Rear Seat Removal)
 - Mounting Bolt [A]
 - Set Bracket (rear) [B]
- Remove the front seat [C] by pulling up the rear of it and to the rear.

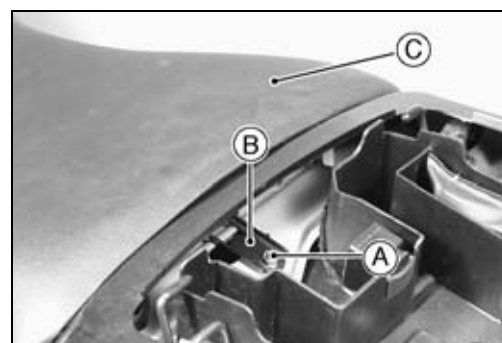

Front Seat Installation

- Slip the front seat hook [A] under the brace [B] on the seat bracket (front).

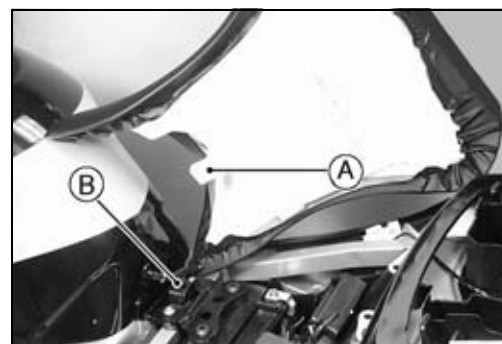

14-6 FRAME

Fairings

Lower Fairing Removal

- Remove:
 - Screws [A] [B]
 - Allen Bolts [C]
- Pull the lower front part of the lower fairing outward to clear the stoppers [D].
- Remove the lower fairing.
- Remove the other side lower fairing in the same manner.

NOTE

○When removing the left and right lower fairings at the same time, do not remove the screws [B] (both sides) and stoppers [D].

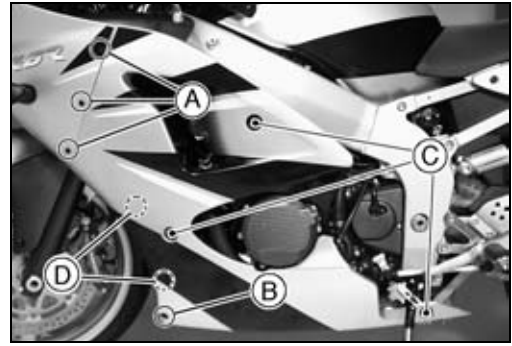

Inner (Upper) Fairing Removal

- Remove:
 - Screws [A]
 - Inner (Upper) Fairing [B]

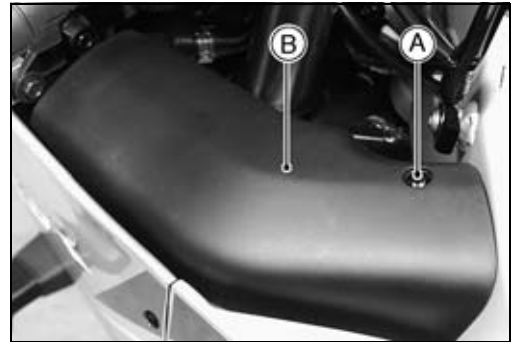

Inner (Lower) Fairing Removal

- Remove:
 - Lower Fairing (Left or Right)
 - Other Side Inner Fairing Screw [B]
 - Inner (Lower) Fairing [A]

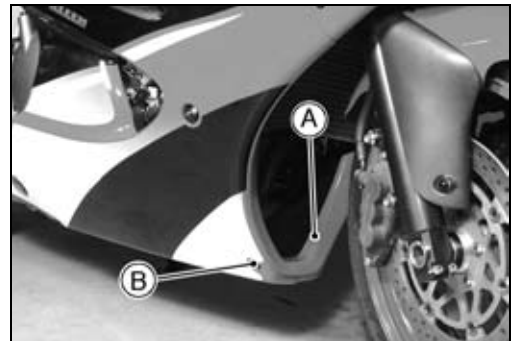

Upper Fairing Removal

- Remove:
 - Inner (Upper) Fairings
 - Spring Bands [A] (Left and Right)
 - Screws [B] (Left and Right)

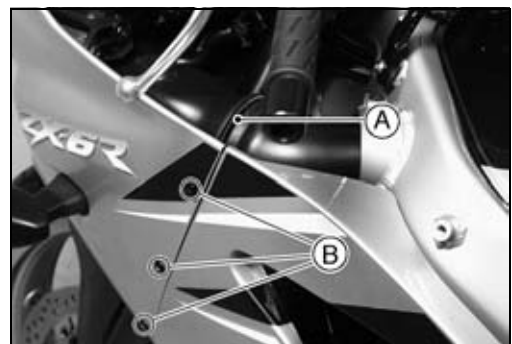

Fairings

- Remove:
Rear View Mirrors [A]
Bolts [B]

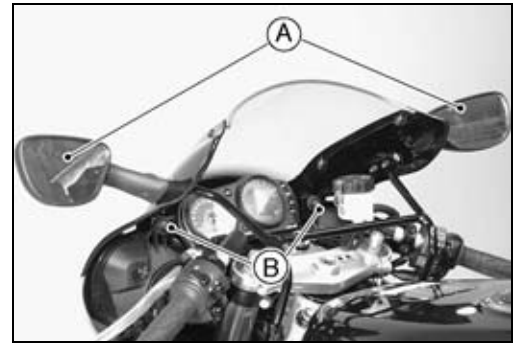

- Remove:
Air Vent Filter Hose [A]
Headlight/Turn Signal Light Lead Connector [B]
Upper Fairing

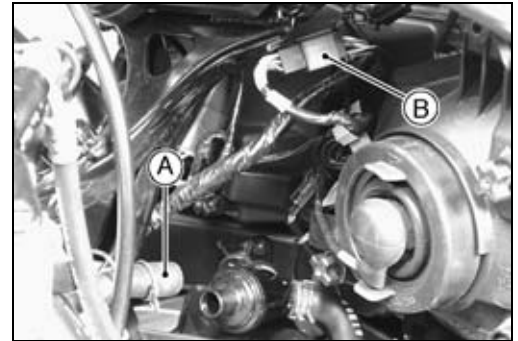

14-8 FRAME

Seat Covers

Seat Cover Removal

- Remove:
 - Seats
 - Bolts and Grab Rails [A]
 - Screws and Seat Lock [B]
 - Screws [C] (Left and Right)
- Pull the seat cover backward.

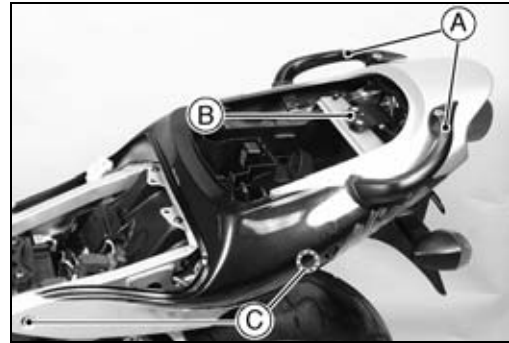

Seat Cover Installation

- Set the seat cover [A], and insert the rivet [B] into the holes in the seat cover and rear fender.
- Push in the screw [C] into the rivet.
- Install the grab rails and tighten the bolts.
Torque - Grab Rail Bolts: 25 N·m (2.5 kgf·m, 18 ft·lb)
- Install the remove parts.

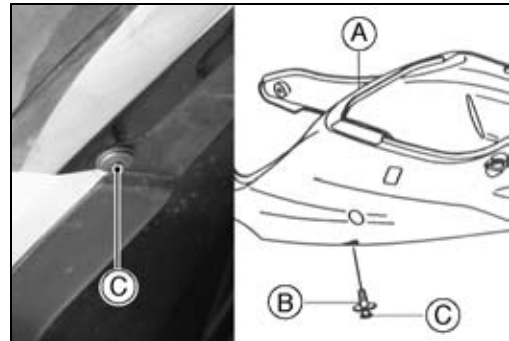

Fenders

Front Fender Removal

- Remove:
 - Brake Hose Clamps [A] (Left and Right)
 - Bolts [B] and Screws [C] (Left and Right)
- Remove the front fender [D].

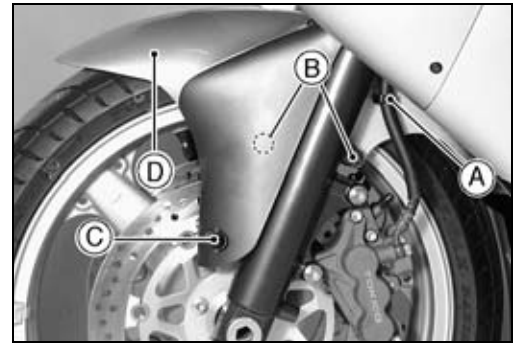

Rear Fender Removal

- Remove:
 - Seats
 - Fuel Tank
 - Seat Cover
 - Junction Box
 - Starter Relay Assy
 - Turn Signal Relay
 - Battery
 - Rear Brake Reservoir Mounting Bolt
 - Tail/Brake Light Lead Connectors [A]
 - Clamp [B]
 - Tail/Brake Light [C]
- Remove:
 - Turn Signal Light Lead Connectors [A]
 - Bolts [B]
- Remove the rear fender rearward.

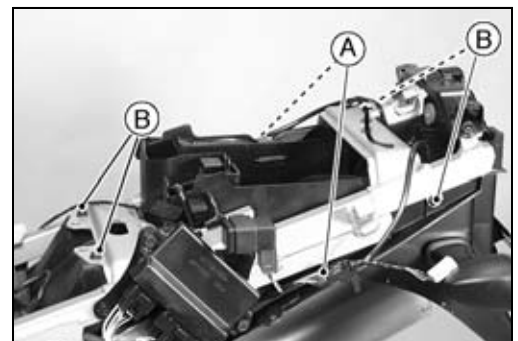
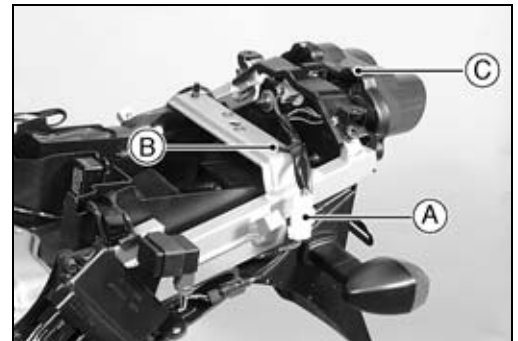

14-10 FRAME

Frame

Rear Frame Removal

- Remove:
 - Rear Fender (see Rear Fender Removal)
 - Bolts [A] and IC Igniter Bracket [B]
 - Clamps for Main Harness
 - Frame Bolts and Nuts [C]

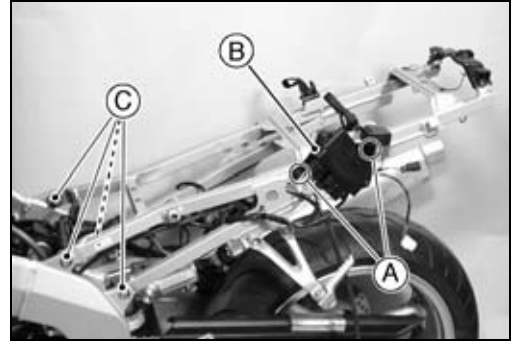

Rear Frame Installation

- Tighten:
 - Torque - Rear Frame Bolts and Nuts: 44 N·m (4.5 kgf·m, 33 ft·lb)

Frame Inspection

- Visually inspect the frame for cracks, dents, bending, or warp.
- ★ If there is any damage to the frame, replace it.

⚠ WARNING

A repaired frame may fail in use, possibly causing an accident. If the frame is bent, dented, cracked, or warped, replace it.

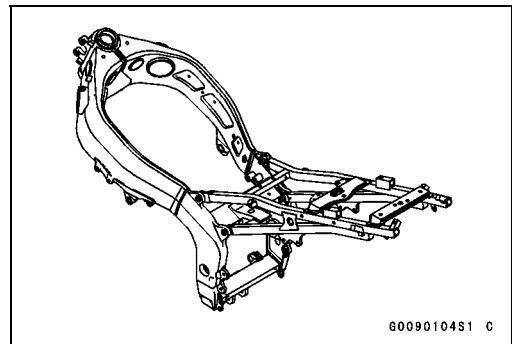

Electrical System

Table of Contents

Exploded View	15-3
Wiring Diagram (United States and Canada) (ZX600-J1 ~ J2)	15-6
Wiring Diagram (United States and Canada) (ZX600-J3 ~)	15-8
Wiring Diagram (Australia)	15-10
Wiring Diagram (Other than United States, Canada, Australia, and Malaysia)	15-12
Wiring Diagram (Malaysia)	15-14
Specifications	15-16
Parts Location	15-18
Precautions	15-19
Electrical Wiring	15-21
Wiring Inspection	15-21
Battery	15-22
Battery Removal	15-22
Electrolyte Filling	15-22
Initial Charge	15-23
Precautions	15-23
Interchange	15-24
Charging Condition Inspection	15-24
Refreshing Charge	15-25
Charging System	15-27
Alternator Cover Removal	15-27
Alternator Cover Installation	15-27
Stator Coil Removal	15-27
Stator Coil Installation	15-27
Alternator Rotor Removal	15-28
Alternator Rotor Installation	15-28
Alternator Inspection	15-29
Regulator/Rectifier Inspection	15-30
Charging Voltage Inspection	15-32
Ignition System	15-35
Crankshaft Sensor Removal	15-36
Crankshaft Sensor Installation	15-37
Crankshaft Sensor Inspection	15-37
Crankshaft Sensor Peak Voltage Measurement	15-38
Stick Coil (Ignition Coil together with Spark Plug Cap) Removal	15-38
Stick Coil (Ignition Coil together with Spark Plug Cap) Installation	15-38
Stick Coil (Ignition Coil together with Spark Plug Cap) Inspection	15-39
Stick Coil Primary Peak Voltage Measurement	15-39
Spark Plug Removal	15-40
Spark Plug Installation	15-40
Spark Plug Cleaning and Inspection	15-40
Spark Plug Gap Inspection	15-41
IC Igniter Inspection	15-41
Electric Starter System	15-46
Starter Motor Removal	15-46
Starter Motor Installation	15-46

15-2 ELECTRICAL SYSTEM

Starter Motor Disassembly.....	15-46
Starter Motor Assembly	15-47
Brush Inspection	15-48
Commutator Cleaning and Inspection.....	15-48
Armature Inspection.....	15-49
Brush Lead Inspection	15-49
Right-hand End Cover Assembly Inspection	15-49
Starter Relay Inspection.....	15-49
Lighting System.....	15-51
Headlight Beam Horizontal Adjustment	15-51
Headlight Beam Vertical Adjustment.....	15-51
Headlight Bulb Replacement	15-51
Headlight Relay Unit Inspection.....	15-52
Turn Signal Relay Inspection	15-54
Fuel Pump	15-56
Fuel Pump Removal/Installation	15-56
Fuel Pump Relay Internal Resistance Inspection	15-56
Fuel Pump Operational Inspection.....	15-57
Fuel Cut Valve	15-59
Fuel Cut Valve Removal	15-59
Fuel Cut Valve Installation	15-59
Fuel Cut Valve Inspection	15-59
Radiator Fan System.....	15-61
Fan System Circuit Inspection	15-61
Fan Motor Inspection	15-61
Meter, Gauge, Indicator Unit.....	15-63
Meter Unit Removal	15-63
Meter, Gauge Disassembly.....	15-63
Bulb Replacement.....	15-63
Electronic Combination Meter Unit Inspection	15-64
Switches and Sensors	15-68
Brake Light Timing Inspection.....	15-68
Brake Light Timing Adjustment	15-68
Switch Inspection	15-68
Radiator Fan Switch Inspection	15-69
Water Temperature Sensor Inspection	15-70
Throttle Sensor Removal/Installation	15-70
Throttle Sensor Inspection	15-70
Throttle Sensor Position Adjustment.....	15-71
Speed Sensor Inspection.....	15-72
Junction Box	15-73
Junction Box Fuse Circuit Inspection	15-73
Starter Circuit/Headlight Relay Inspection	15-73
Diode Circuit Inspection	15-74
Fuse.....	15-76
30 A Main Fuse Removal.....	15-76
Junction Box Fuse Removal	15-76
Fuse Installation.....	15-76
Fuse Inspection.....	15-76

Exploded View

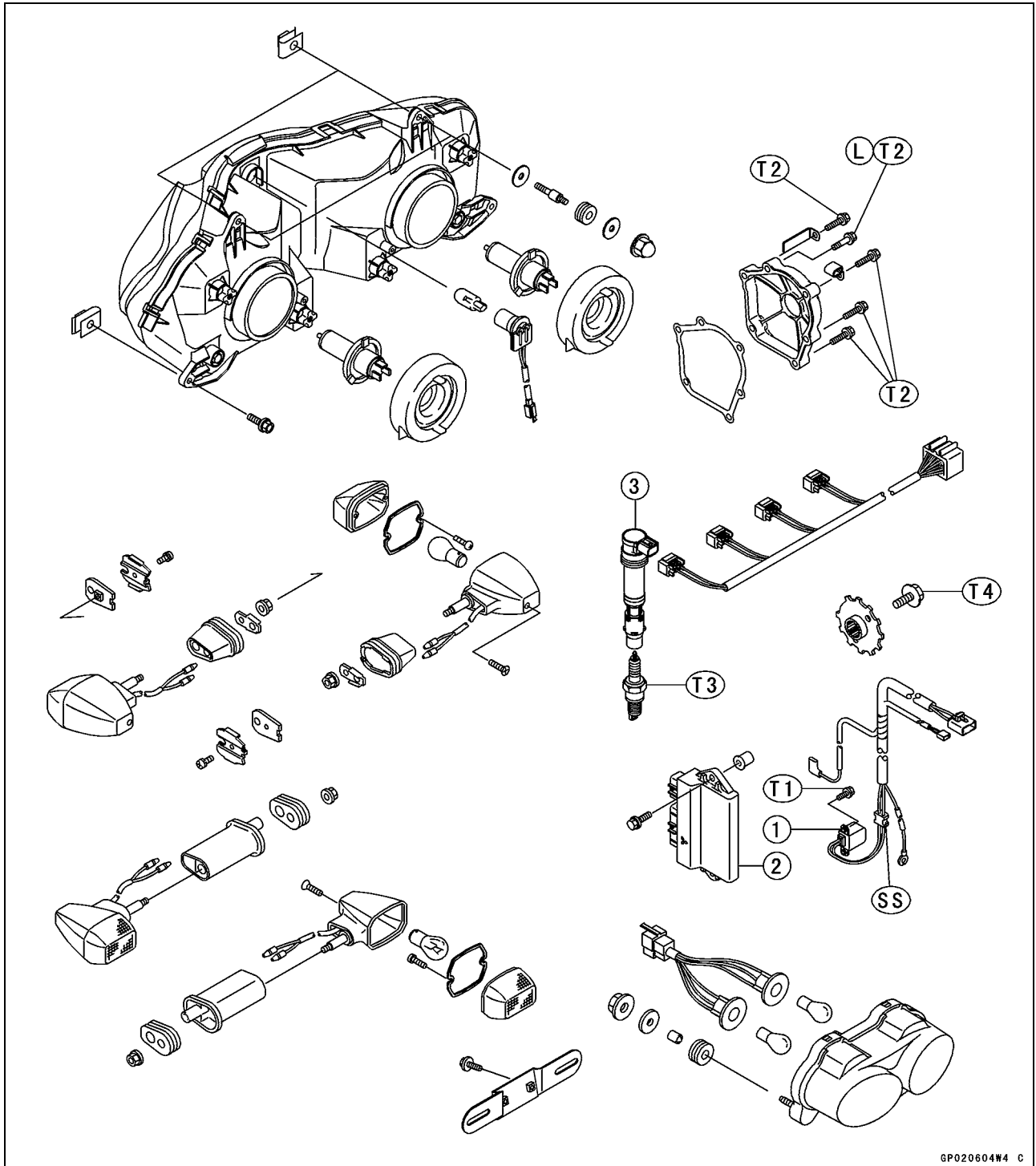

- 1. Crankshaft Sensor
- 2. IC Igniter
- 3. Stick Coils
- T1: 5.9 N·m (0.60 kgf·m, 52 in·lb)
- T2: 12 N·m (1.2 kgf·m, 104 in·lb)
- T3: 13 N·m (1.3 kgf·m, 113 in·lb)
- T4: 44 N·m (4.5 kgf·m, 33 ft·lb)
- L: Apply a non-permanent locking agent.
- SS: Apply silicone sealant.

15-4 ELECTRICAL SYSTEM

Exploded View

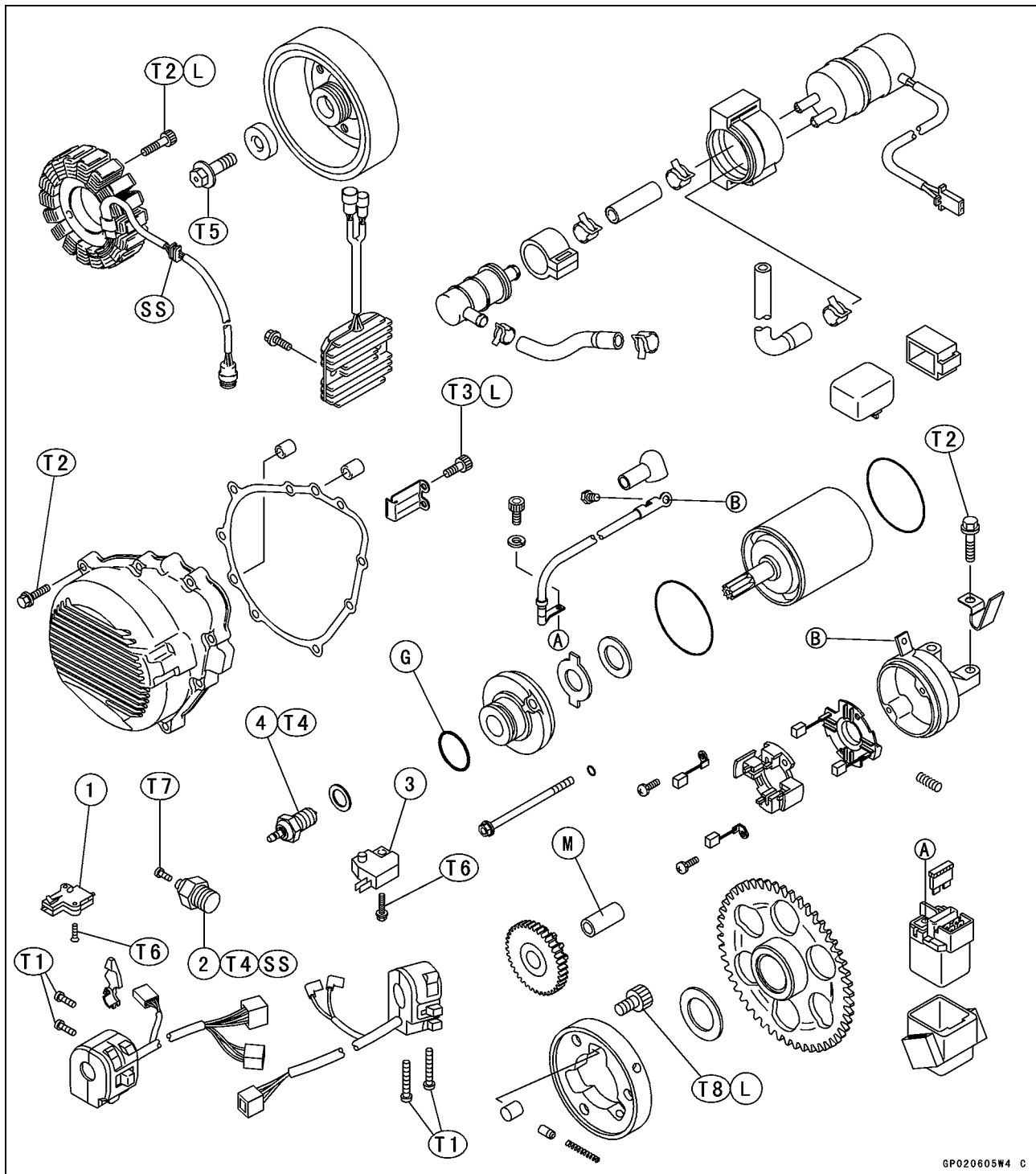

GP020605W4 C

- 1. Starter Lockout Switch
- 2. Oil Pressure Switch
- 3. Front Brake Light Switch
- 4. Neutral Switch
- T1: 3.4 N·m (0.35 kgf·m, 30 in·lb)
- T2: 12 N·m (1.2 kgf·m, 104 in·lb)
- T3: 6.9 N·m (0.70 kgf·m, 61 in·lb)
- T4: 15 N·m (1.5 kgf·m, 11 ft·lb)

- T5: 120 N·m (12 kgf·m, 87 ft·lb)
- T6: 1.0 N·m (0.1 kgf·m, 9 in·lb)
- T7: 1.5 N·m (0.15 kgf·m, 13 in·lb)
- T8: 34 N·m (3.5 kgf·m, 25 ft·lb)
- G: Apply grease or engine oil.
- L: Apply a non-permanent locking agent.
- M: Apply molybdenum disulfide grease.
- SS: Apply silicone sealant.

Exploded View

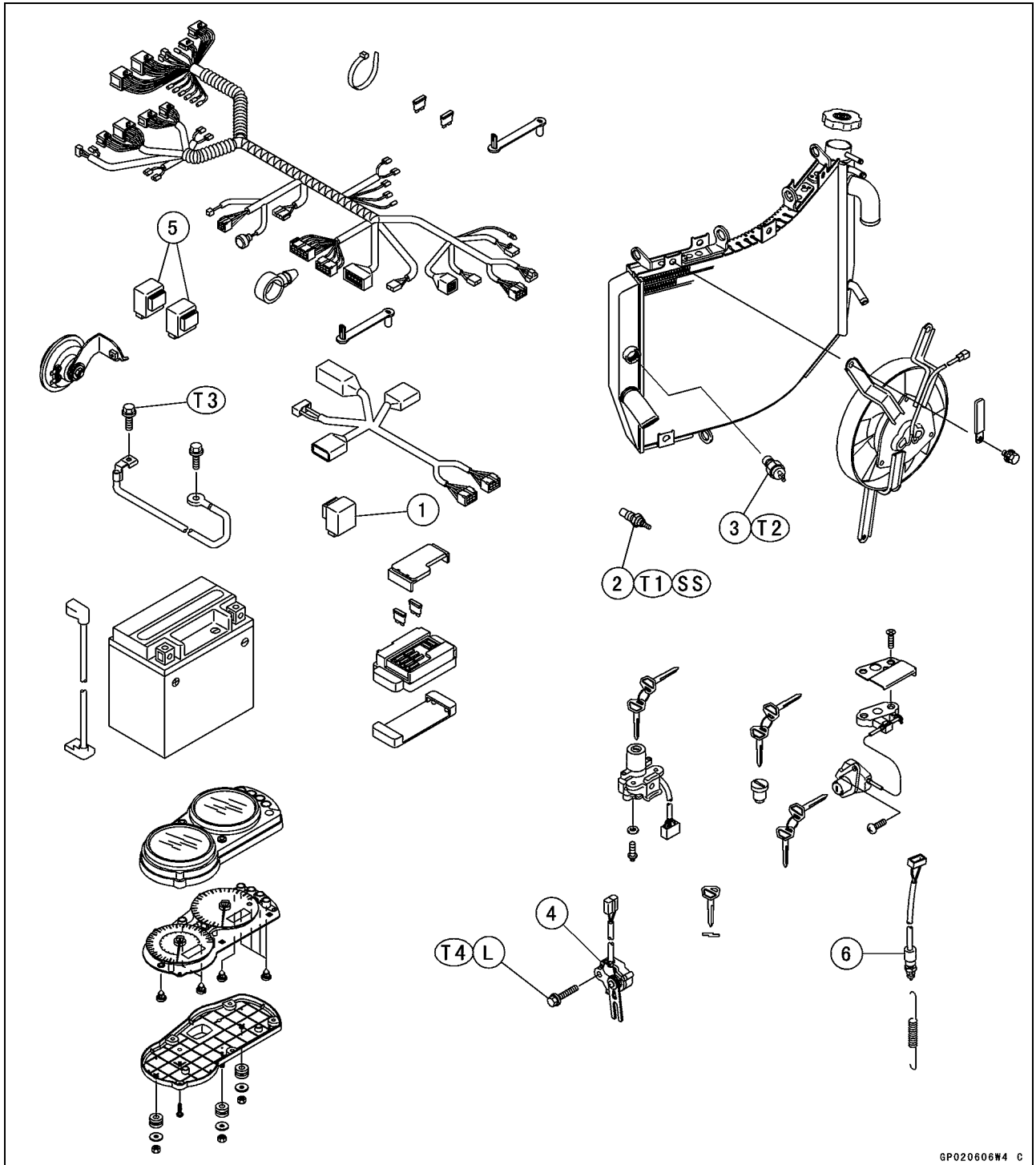

GP020606W4 C

1. Turn Signal Relay
 2. Water Temperature Sensor
 3. Fan Switch
 4. Side Stand Switch
 5. Headlight Relays
 6. Rear Brake Light Switch
- T1: 7.8 N·m (0.80 kgf·m, 69 in·lb)
 T2: 18 N·m (1.8 kgf·m, 13 ft·lb)
 T3: 9.8 N·m (1.0 kgf·m, 87 in·lb)
 T4: 8.8 N·m (0.90 kgf·m, 78 in·lb)
- L: Apply a non-permanent locking agent.
 SS: Apply silicone sealant.

15-6 ELECTRICAL SYSTEM

Wiring Diagram (United States and Canada) (ZX600-J1 ~ J2)

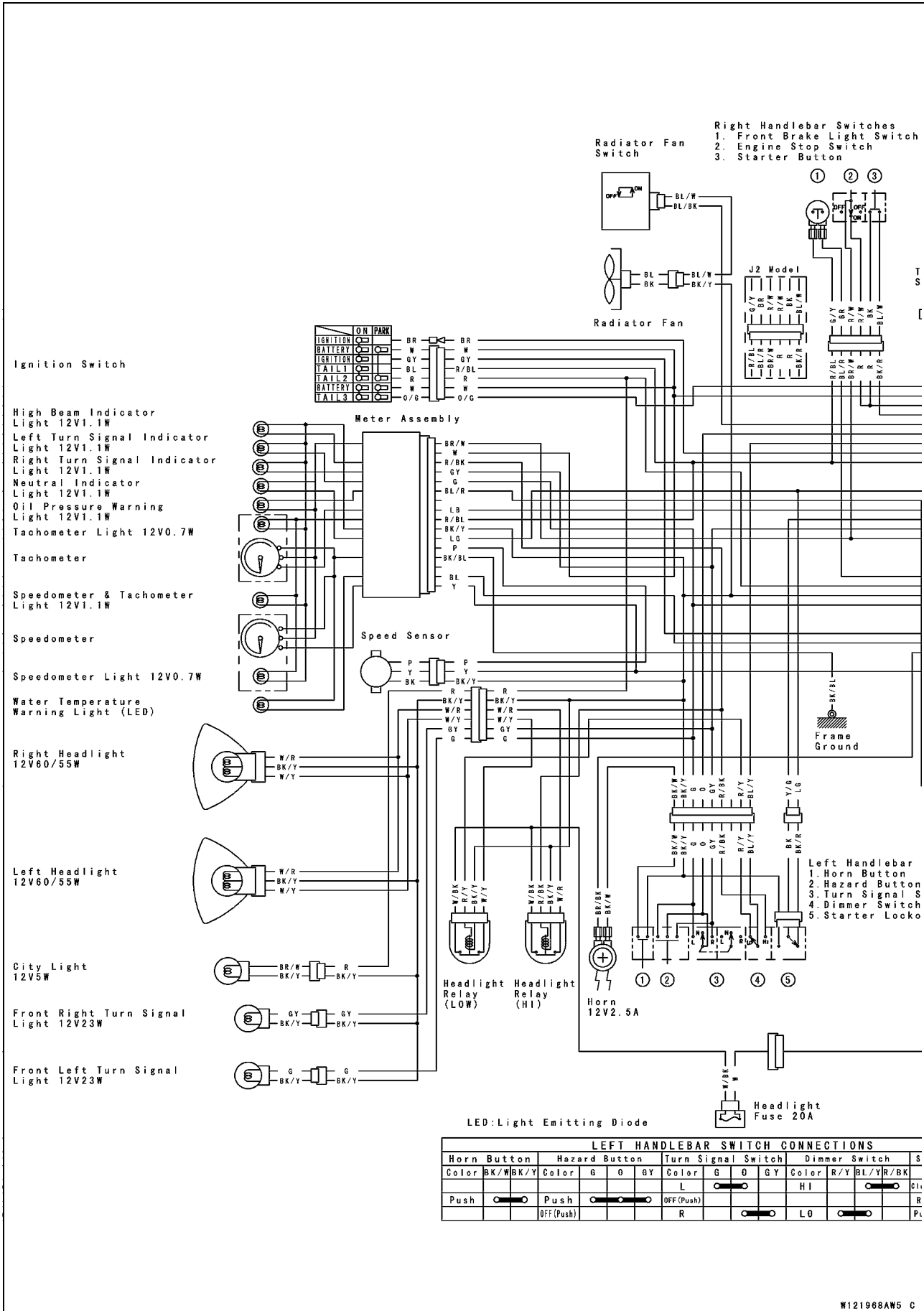

Wiring Diagram (United States and Canada) (ZX600-J1 ~ J2)

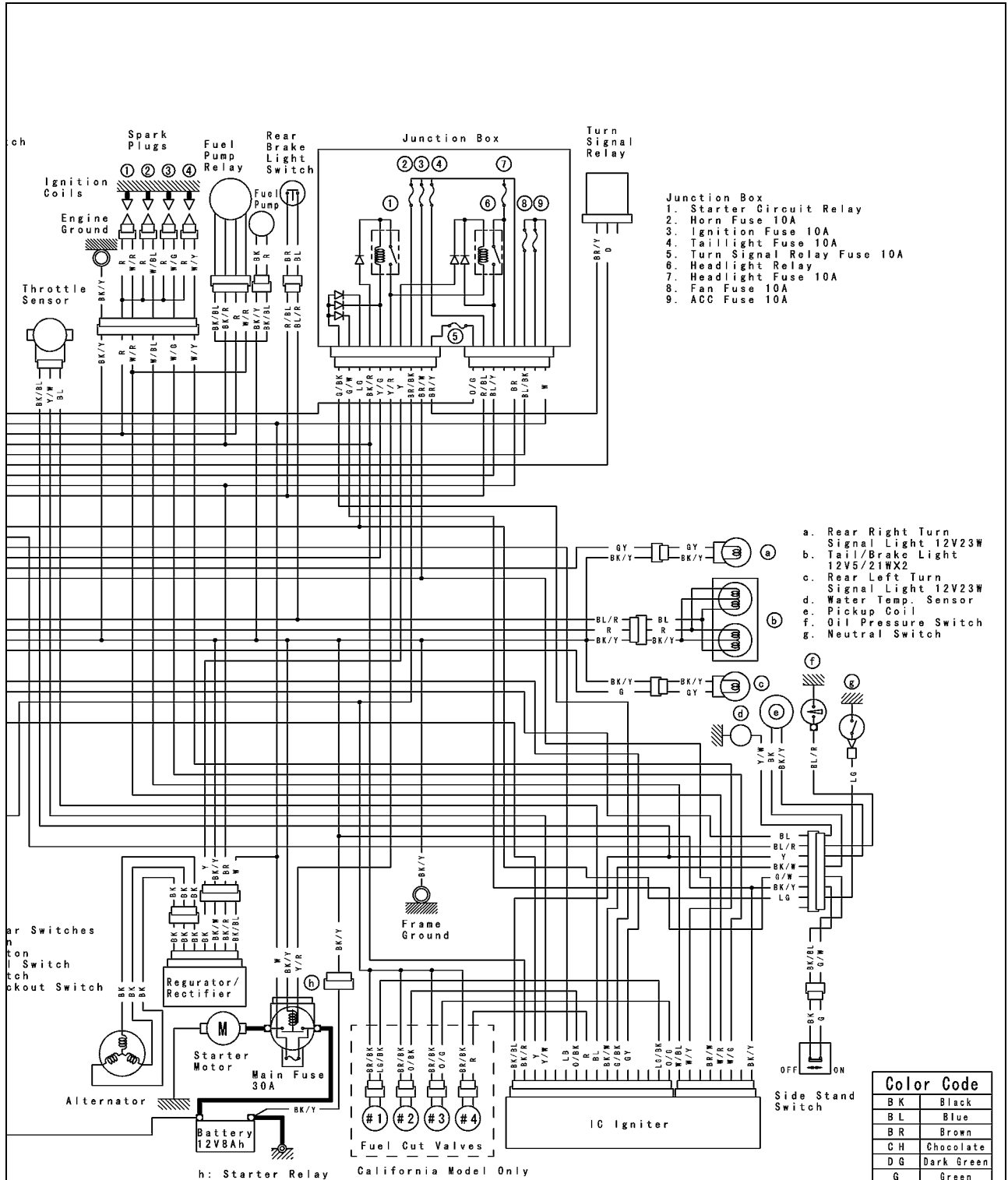

Starter Lockout Switch	Color	BK/Y	BK	BK/R
Clutch Lever	Released			
	Pulled in			

IGNITION SWITCH CONNECTIONS						
Color	Ignition	Battery	Ignition	Tail1	Tail2	Tail3
Color	BR	W	GY	BL	R	W
OFF, LOCK						O/G
ON						
P						

RIGHT HANDLEBAR SWITCH CONNECTIONS					
Color	BK	BK	Color	Y/R	R
Front Brake Light Switch			Color		
Brake Lever	OFF		Color		
Pulled in			RUN		
			Push		

(98051-1968A, 1969A)

Color Code	
BK	Black
BL	Blue
BR	Brown
CH	Chocolate
DG	Dark Green
G	Green
GY	Gray
LB	Light Blue
LG	Light Green
O	Orange
P	Pink
PU	Purple
R	Red
W	White
Y	Yellow

15-8 ELECTRICAL SYSTEM

Wiring Diagram (United States and Canada) (ZX600-J3 ~)

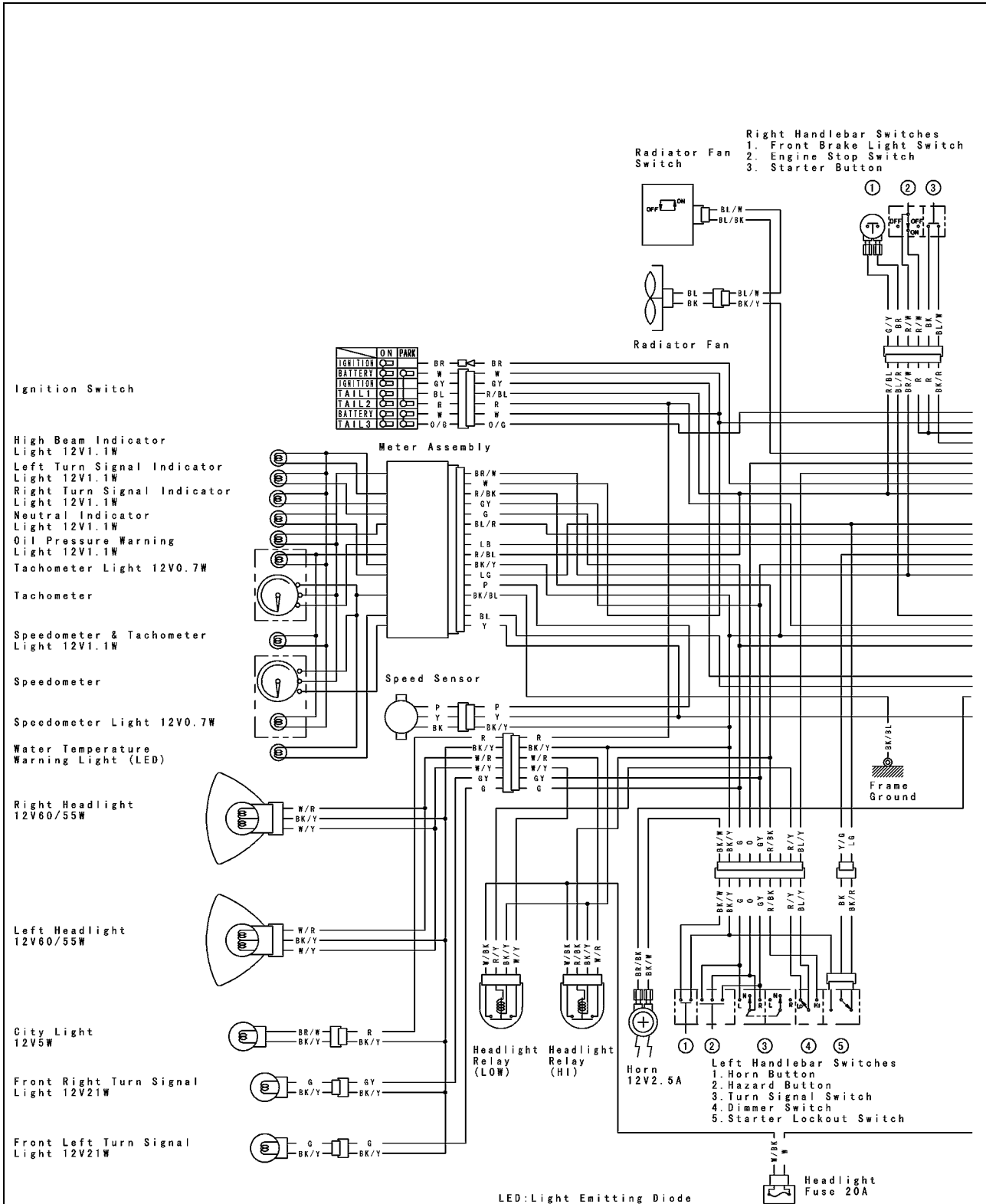

LEFT HANDLEBAR SWITCH CONNECTIONS

Horn Button	Hazard Button	Turn Signal Switch	Dimmer Switch	Starter Lockout Switch
Color BK/WBK/Y	Color G O GY	Color G O GY	Color R/Y BL/YR/BK	Color BK/Y BK BK/R
Push	Push	OFF (Push)	HI	Clutch Lever Released
	OFF (Push)	R	LO	Pulled in

Wiring Diagram (United States and Canada) (ZX600-J3 ~)

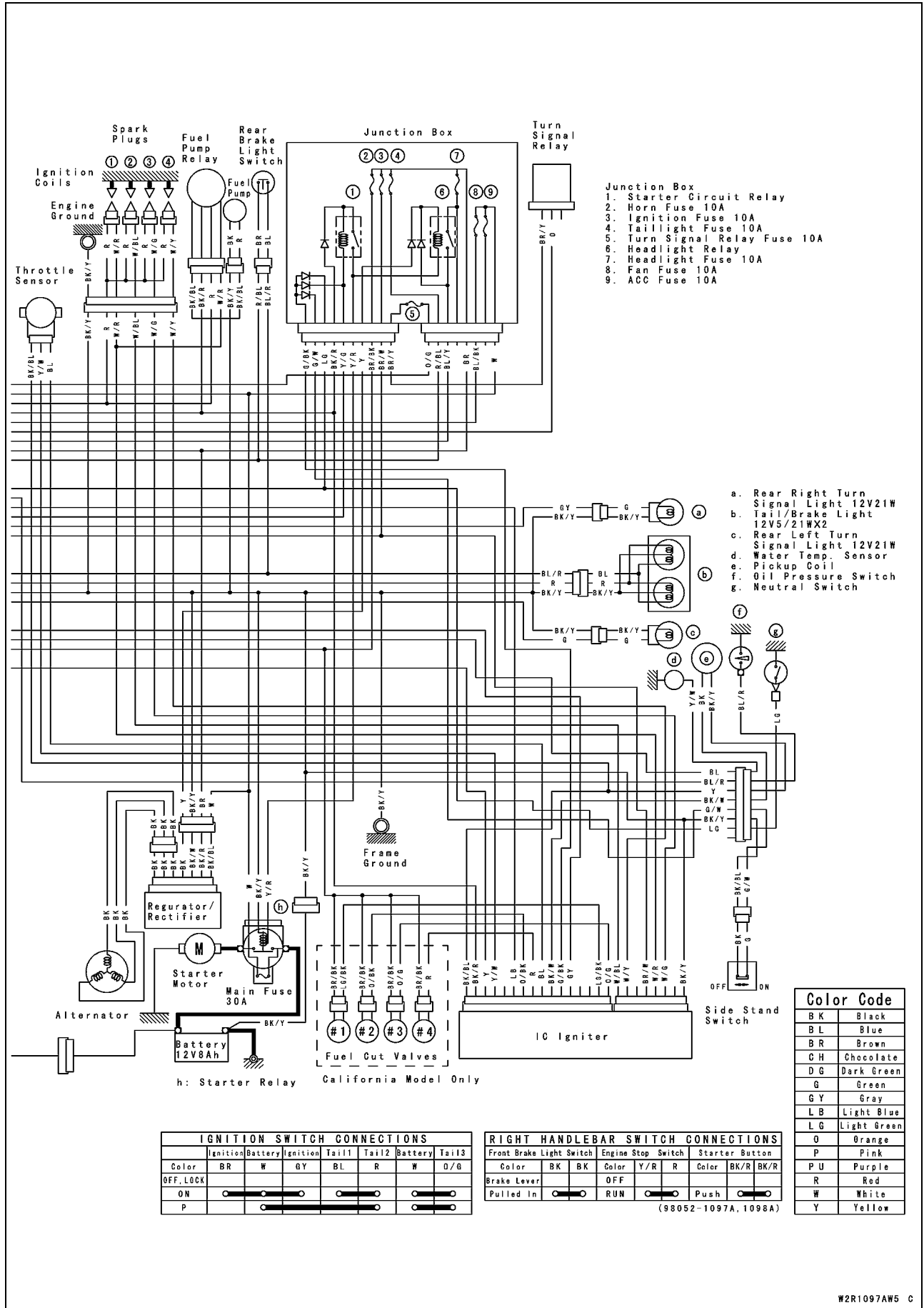

- Junction Box**
- 1. Starter Circuit Relay
 - 2. Horn Fuse 10A
 - 3. Ignition Fuse 10A
 - 4. Taillight Fuse 10A
 - 5. Turn Signal Relay Fuse 10A
 - 6. Headlight Fuse 10A
 - 7. Headlight Fuse 10A
 - 8. Fan Fuse 10A
 - 9. ACC Fuse 10A

- a. Rear Right Turn Signal Light 12V21W
- b. Tail/Brake Light 12V5/21WX2
- c. Rear Left Turn Signal Light 12V21W
- d. Water Temp. Sensor
- e. Pickup Coil
- f. Oil Pressure Switch
- g. Neutral Switch

IGNITION SWITCH CONNECTIONS						
Color	Ignition	Battery	Ignition	Tail1	Tail2	Tail3
OFF, LOCK	BR	W	GY	BL	R	W
ON	[Circuit diagram showing connections for ON position]					
P	[Circuit diagram showing connections for P position]					

RIGHT HANDLEBAR SWITCH CONNECTIONS					
Color	BK	BK	Color	Y/R	R
Front Brake Light Switch	[Circuit diagram]				
Brake Lever	[Circuit diagram]				
Pulled In	[Circuit diagram]				

(98052-1097A, 1098A)

Color Code	
BK	Black
BL	Blue
BR	Brown
CH	Chocolate
DG	Dark Green
G	Green
GY	Gray
LB	Light Blue
LG	Light Green
O	Orange
P	Pink
PU	Purple
R	Red
W	White
Y	Yellow

15-10 ELECTRICAL SYSTEM

Wiring Diagram (Australia)

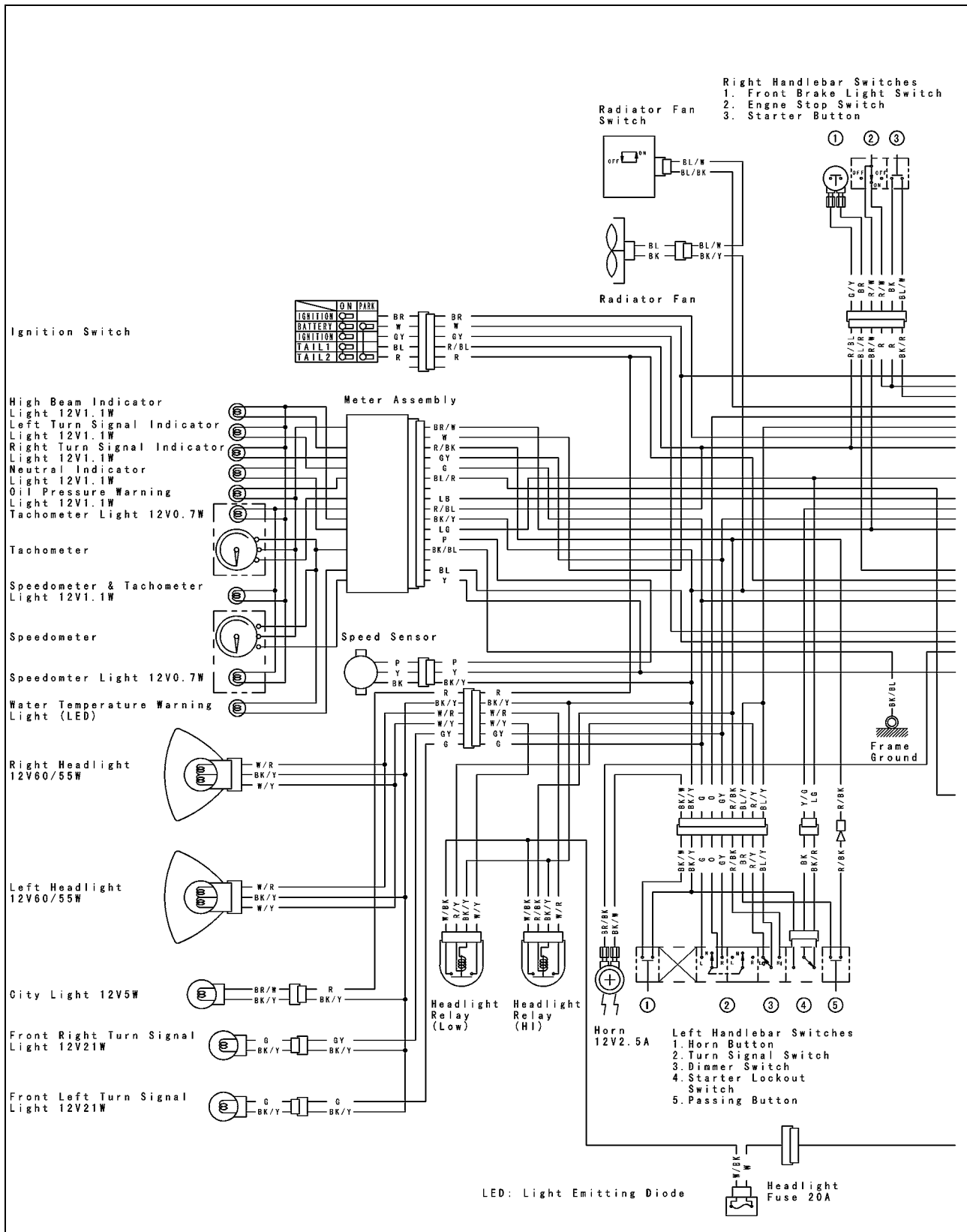

LEFT HANDLEBAR SWITCH CONNECTIONS						
Horn Button	Turn Signal Switch	Dimmer Switch	Starter Lockout Switch	Passing Button		
Color BK/W/BK/Y	Color G O GY	Color R/Y BL/Y R/BK	Color BK/Y BK BK/R	Color BR R/BK		
Push	L	HI	Clutch Lever	Released	Push	
	OFF (Push)	LO	Pulled in			
	R					

Wiring Diagram (Australia)

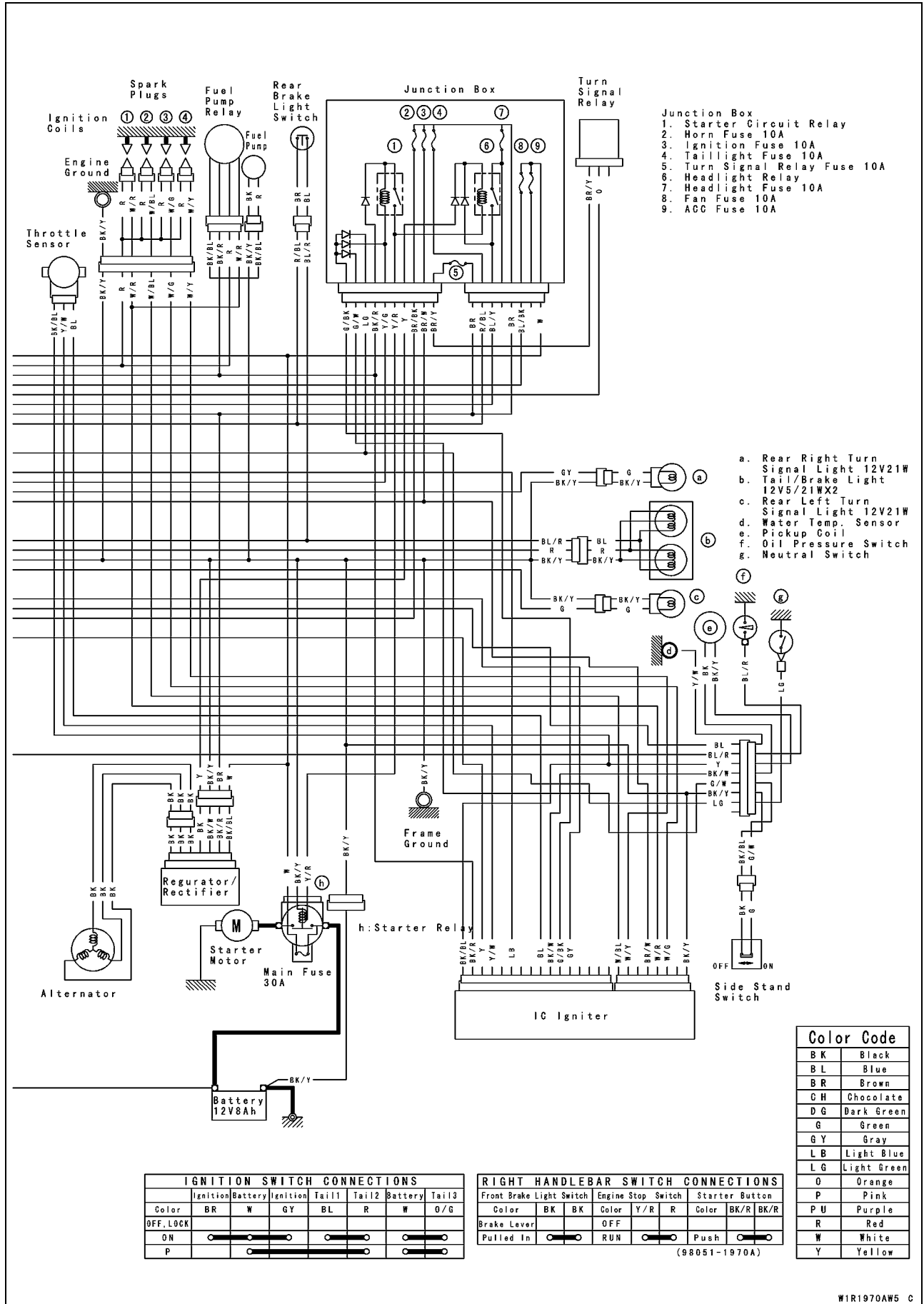

15-12 ELECTRICAL SYSTEM

Wiring Diagram (Other than United States, Canada, Australia, and Malaysia)

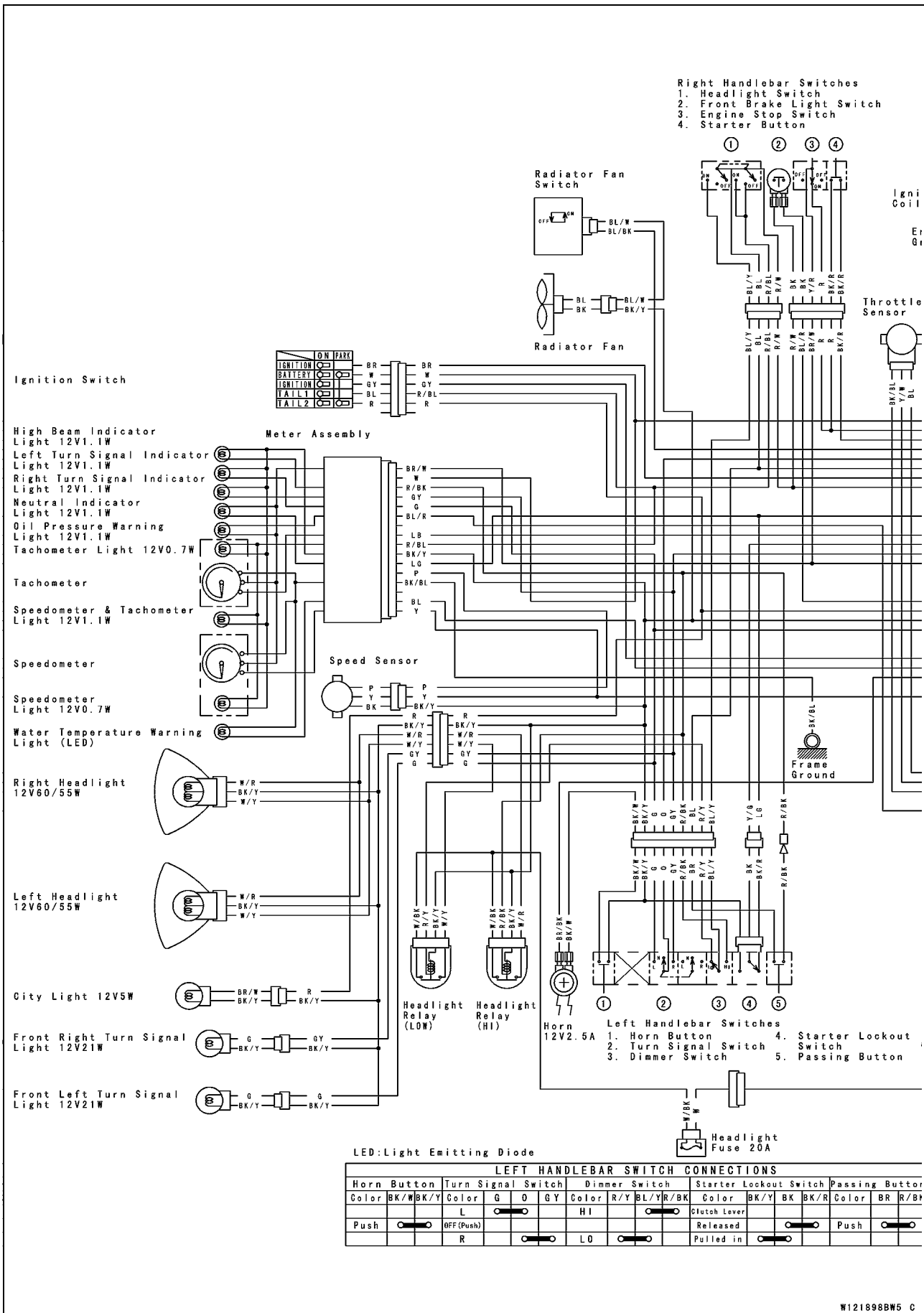

Wiring Diagram (Other than United States, Canada, Australia, and Malaysia)

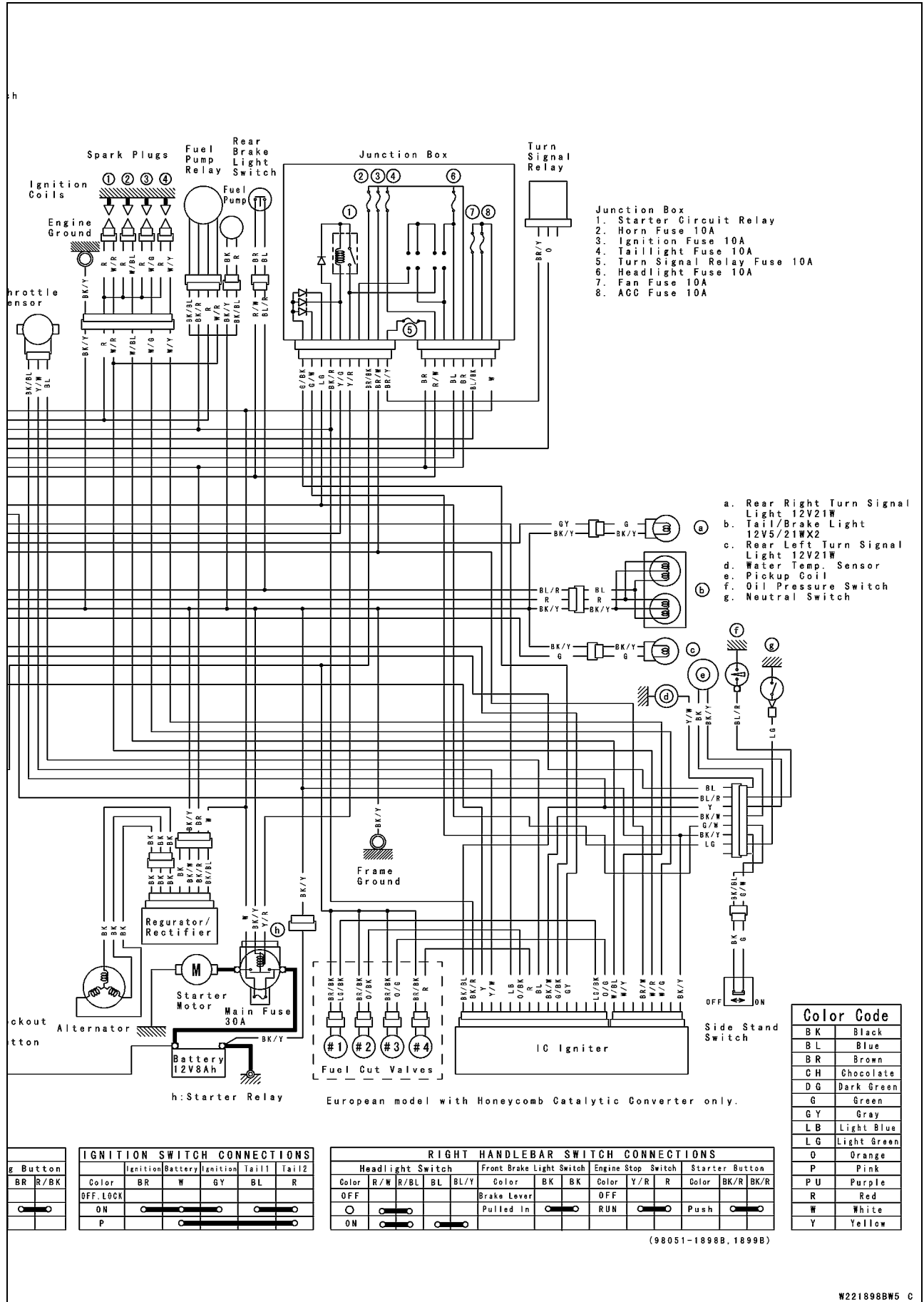

15-14 ELECTRICAL SYSTEM

Wiring Diagram (Malaysia)

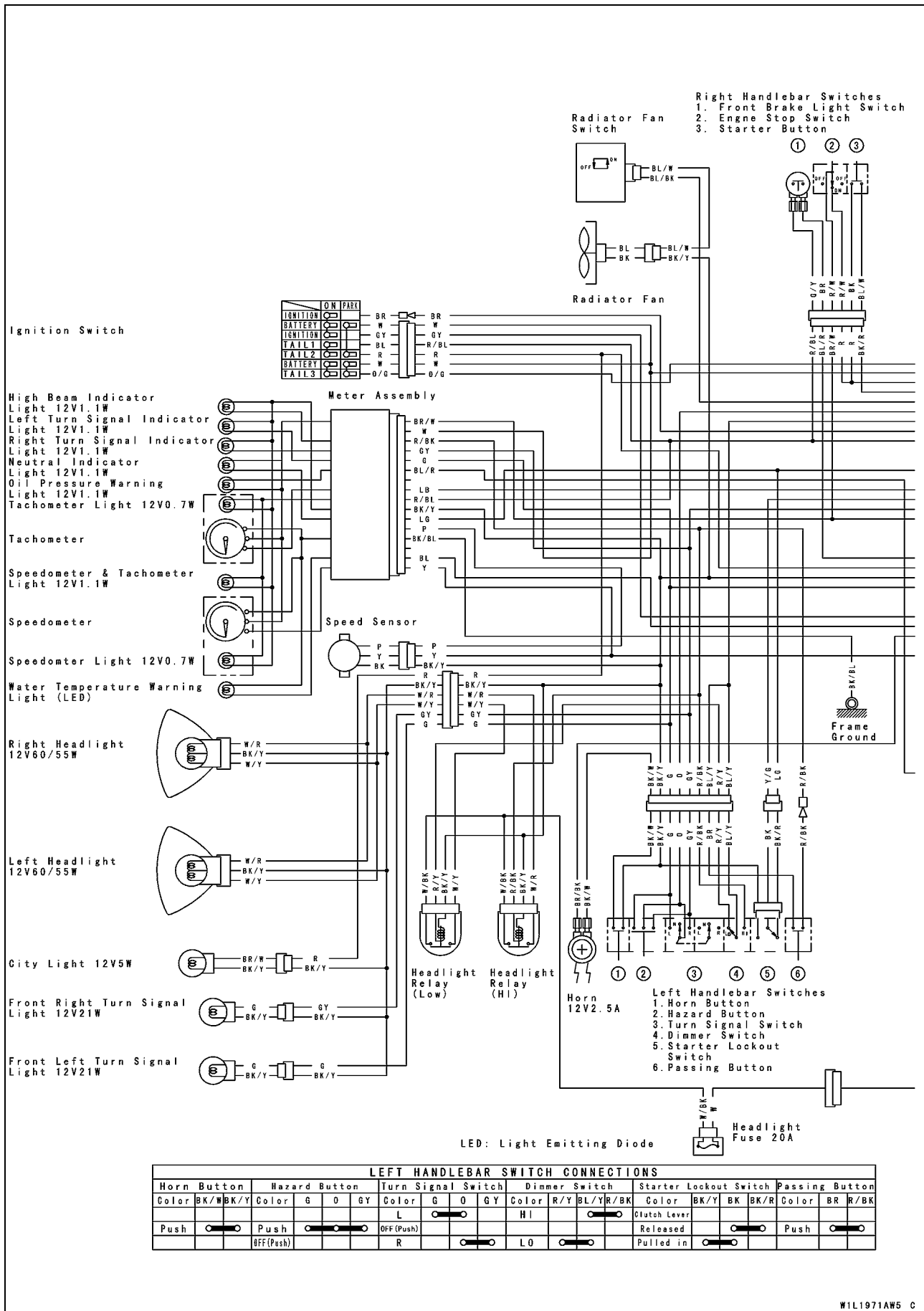

Wiring Diagram (Malaysia)

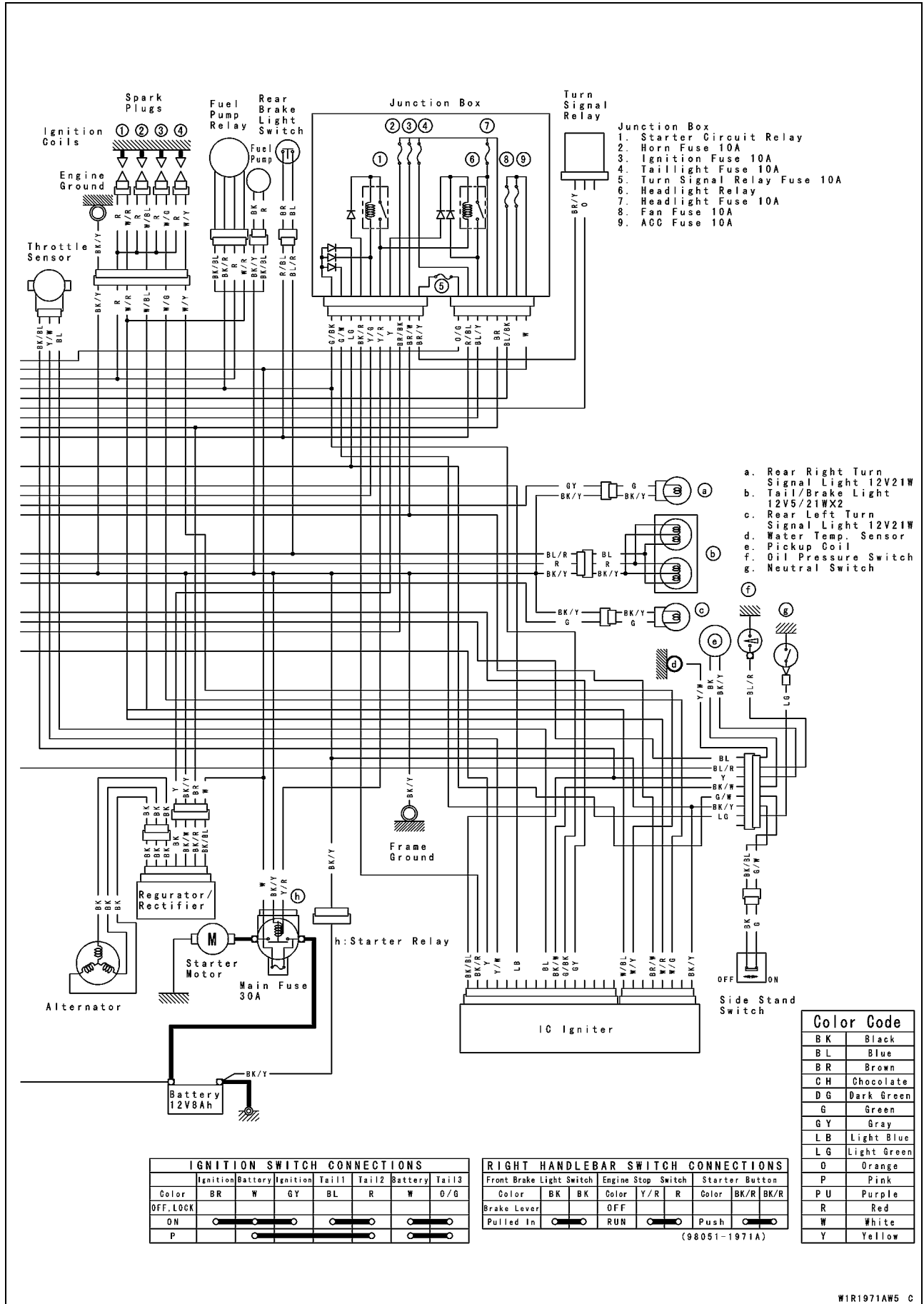

15-16 ELECTRICAL SYSTEM

Specifications

Item	Standard
Battery Type Capacity Voltage	Sealed Battery 12 V 8 Ah 12.8 V or more
Charging System Type Alternator Output Voltage Stator Coil Resistance Charging Voltage (Regulator/Rectifier Output Voltage)	Three-phase AC 53.5 ~ 72.5 V 0.3 ~ 0.4 Ω 14.7 ±0.5 V
Ignition System Crankshaft Sensor Resistance Crankshaft Sensor Peak Voltage Stick Coil: Primary Winding Resistance Secondary Winding Resistance Primary Peak Voltage Spark Plug: Spark Plug Gap IC Igniter Inspection:	452 ~ 462 Ω 3.8 V or more 1.2 ~ 1.6 Ω 8.5 ~ 11.5 kΩ 92 V or more 0.7 ~ 0.8 mm (0.028 ~ 0.031 in.) in the text
Electric Starter System Starter Motor: Brush Length Commutator Diameter	7 mm (0.28 in.) (Service limit 3.5 mm (0.14 in.)) 24 mm (0.94 in.) (Service limit 23 mm (0.91 in.))
Fuel Pump Fuel Pump Relay Internal Resistance Fuel Pump Pressure	in the text 11 ~ 16 kPa (0.11 ~ 0.16 kgf/cm ² , 1.6 ~ 2.3 psi)
Fuel Cut Valve Fuel Cut Valve Protrusion	When battery is disconnected: 16.6 mm (0.65 in.) When battery is connected: 18.6 ~ 19.1 mm (0.73 ~ 0.75 in.)
Switch And Sensor Speedometer Sensor Rear Brake Light Switch Timing Engine Oil Pressure Switch Connections Fan Switch Connections Rising Temperature Falling Temperature Water Temperature Sensor Resistance	in the text ON after about 10 mm (3.94 in.) pedal travel When engine is stopped: ON When engine is running: OFF From OFF to ON @96 ~ 100°C (205 ~ 212°F) From ON to OFF @below 91°C (196°F) or less ON: Less than 0.5 Ω OFF: More than 1 MΩ 50°C (122°F) 9.18 ~ 9.94 kΩ 80°C (176°F) 2.50 ~ 3.06 kΩ 120°C (248°F) 0.65 ~ 0.73 kΩ

Specifications

Item	Standard
Throttle Sensor Output Voltage	When engine is idling: 0.95 ~ 1.05 V When engine is fully opened: 3.95 ~ 4.15 V

Special Tools - Carburetor Drain Plug Wrench, Hex 3: 57001-1269

Flywheel Holder: 57001-1313

Hand Tester: 57001-1394

Flywheel Puller Assembly, M38 × 1.5/M35 × 1.5: 57001-1405

Peak Voltage Adapter: 57001-1415

Lead Wire-Peak Voltage Adapter: 57001-1449

Needle Adapter Set: 57001-1457

Throttle Sensor Setting Adapter: 57001-1521

Sealant - Kawasaki Bond (Silicone Sealant): 56019-120

15-18 ELECTRICAL SYSTEM

Parts Location

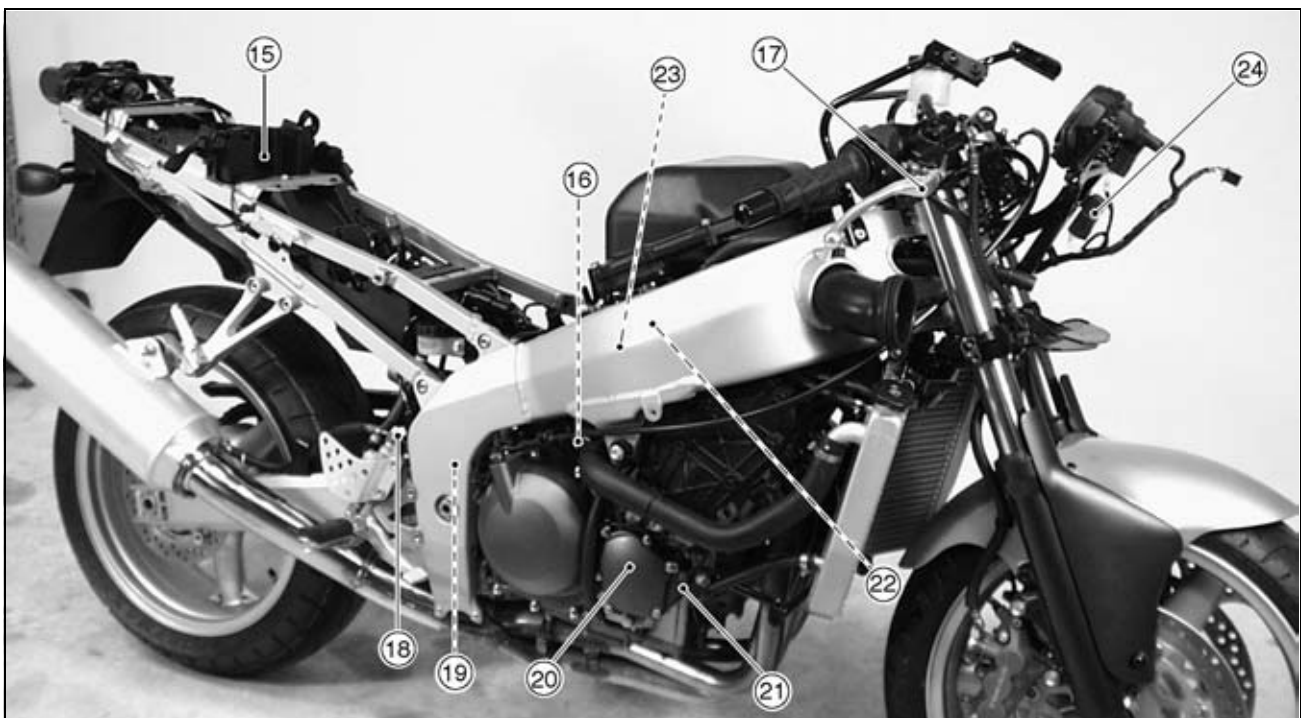
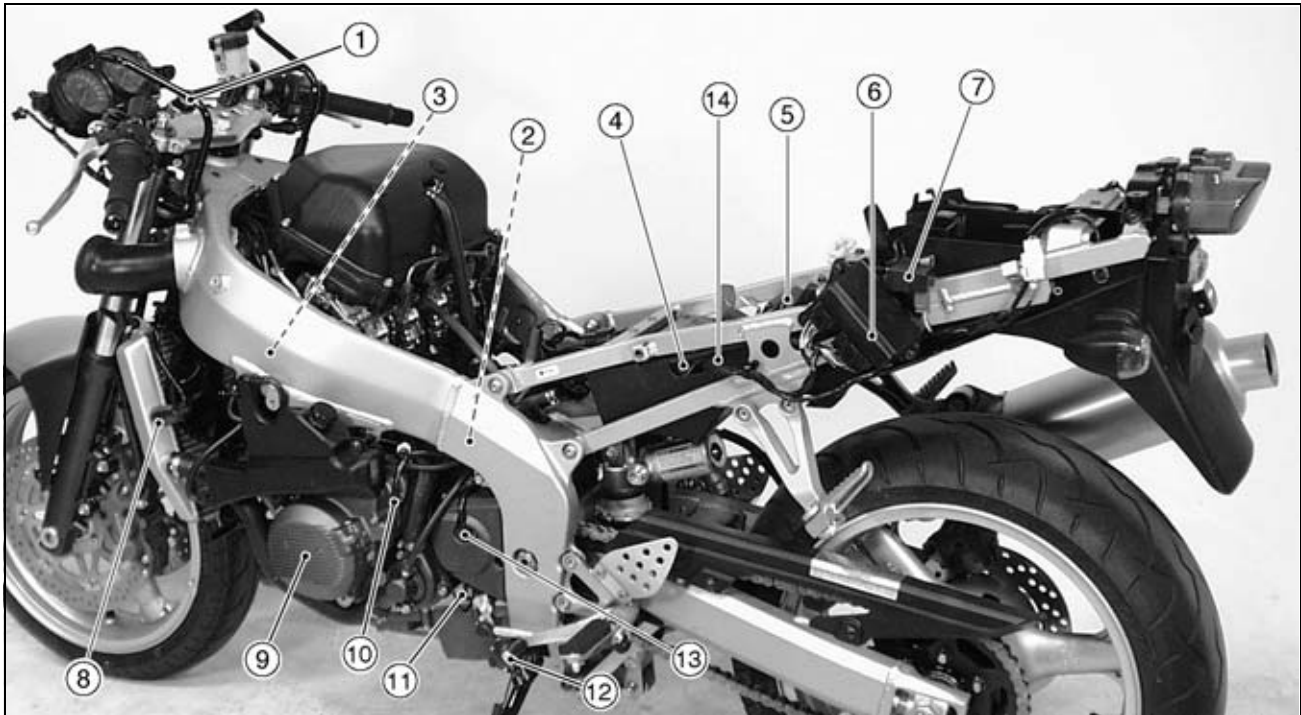

- | | | |
|-----------------------------|---------------------------------|-------------------------------------|
| 1. Starter Lockout Switch | 11. Neutral Switch | 21. Oil Pressure Switch |
| 2. Water Temperature Sensor | 12. Side Stand Switch | 22. Throttle Sensor |
| 3. Stick Coils | 13. Speed Sensor | 23. Fuel Cut Valves (CAL, H Models) |
| 4. Battery | 14. Starter Relay and Main Fuse | 24. Headlight Relay |
| 5. Junction Box | 15. Turn Signal Relay | |
| 6. IC Igniter | 16. Fuel Pump | |
| 7. Fuel Pump Relay | 17. Front Brake Light Switch | |
| 8. Radiator Fan Switch | 18. Rear Brake Light Switch | |
| 9. Alternator | 19. Regulator/Rectifier | |
| 10. Starter Motor | 20. Crankshaft Sensor | |

CAL: California
H: WVTA Approval Model with Honeycomb Catalytic Converter

Precautions

There are a number of important precautions that are musts when servicing electrical systems. Learn and observe all the rules below.

- Do not reverse the battery cable connections. This will burn out the diodes on the electrical parts.
- Always check battery condition before condemning other parts of an electrical system. A fully charged battery is a must for conducting accurate electrical system tests.
- The electrical parts should never be struck sharply, as with a hammer, or allowed to fall on a hard surface. Such a shock to the parts can damage them.
- To prevent damage to electrical parts, do not disconnect the battery cables or any other electrical connections when the ignition switch is on, or while the engine is running.
- Because of the large amount of current, never keep the starter button pushed when the starter motor will not turn over, or the current may burn out the starter motor windings.
- Do not use a meter illumination bulb rated for other than voltage or wattage specified in the wiring diagram, as the meter or gauge panel could be warped by excessive heat radiated from the bulb.
- Take care not to short the leads that are directly connected to the battery positive (+) terminal to the chassis ground.
- Troubles may involve one or in some cases all items. Never replace a defective part without determining what CAUSED the failure. If the failure was caused by some other item or items, they must be repaired or replaced, or the new replacement will soon fail again.
- Make sure all connectors in the circuit are clean and tight, and examine leads for signs of burning, fraying, etc. Poor leads and bad connections will affect electrical system operation.
- Measure coil and winding resistance when the part is cold (at room temperature).
- Color Codes:

BK: Black	G: Green	P: Pink
BL: Blue	GY: Gray	PU: Purple
BR: Brown	LB: Light Blue	R: Red
CH: Chocolate	LG: Light Green	W: White
DG: Dark Green	O: Orange	Y: Yellow

- Electrical Connectors
Connectors [A]

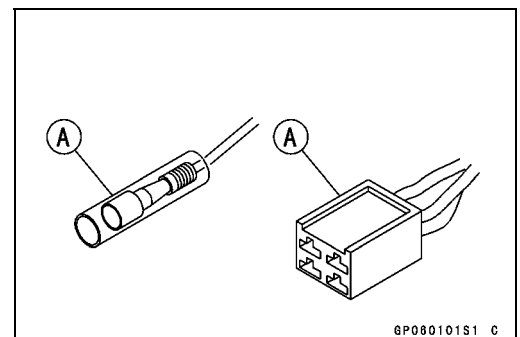

15-20 ELECTRICAL SYSTEM

Precautions

Connectors [B]

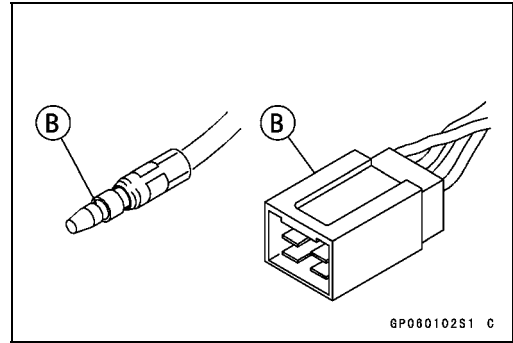

Electrical Wiring

Wiring Inspection

- Visually inspect the wiring for signs of burning, fraying, etc.
- ★ If any wiring is poor, replace the damaged wiring.
- Pull each connector [A] apart and inspect it for corrosion, dirt, and damage.
- ★ If the connector is corroded or dirty, clean it carefully. If it is damaged, replace it.
- Check the wiring for continuity.
- Use the wiring diagram to find the ends of the lead which is suspected of being a problem.
- Connect the hand tester between the ends of the leads.

Special Tool - Hand Tester: 57001-1394

- Set the tester to the $\times 1 \Omega$ range, and read the tester.
- ★ If the tester does not read 0Ω , the lead is defective. Replace the lead or the wiring harness [B] if necessary.

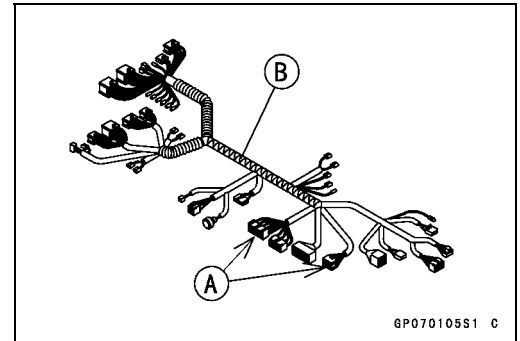

15-22 ELECTRICAL SYSTEM

Battery

Battery Removal

- Remove:
 - Seats (see Frame Chapter)
 - Front Seat Bracket [A] (Battery Holder)
- Disconnect the negative (-) cable [B] and then positive (+) cable [C].

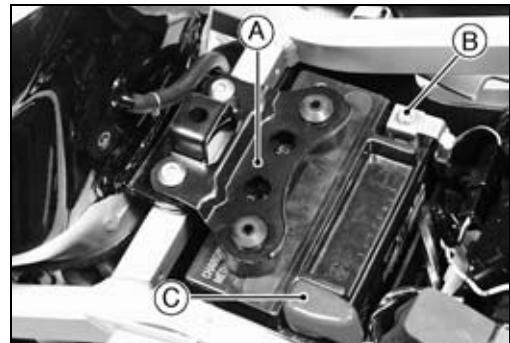

CAUTION

Be sure to disconnect the negative (-) cable first.

- Remove the battery.

Electrolyte Filling

CAUTION

Do not remove the aluminum seal sheet [A] sealing the filler ports [B] until just before use. Be sure to use the dedicated electrolyte container for correct electrolyte volume.

- Check to see that there is no peeling, tears or holes in the seal sheet on the top of the battery.
- Place the battery on a level surface.
- Remove the seal sheet.

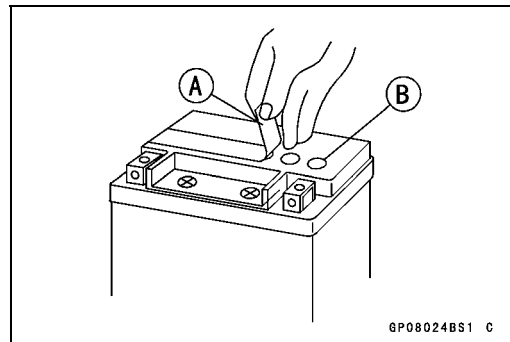

NOTE

○A battery whose seal sheet has any peeling, tears, or holes, requires a refreshing charge (initial charge).

- Take the electrolyte container out of the vinyl bag.
- Detach the seal caps [A] from the container.

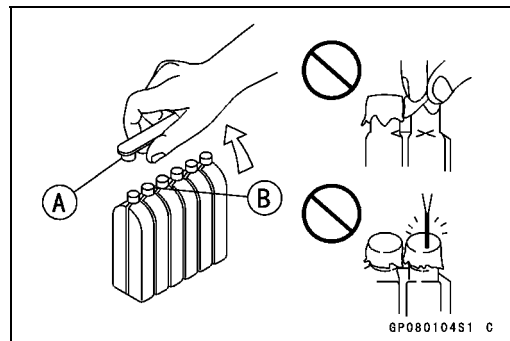

NOTE

○Do not discard the seal caps because it is used as the battery plugs later.

○Do not peel back or pierce the seals [B] on the container.

- Place the electrolyte container upside down aligning six seals with the six battery filler ports.
- Push the container down strongly enough to break the seals. Now the electrolyte should start to flow into the battery.

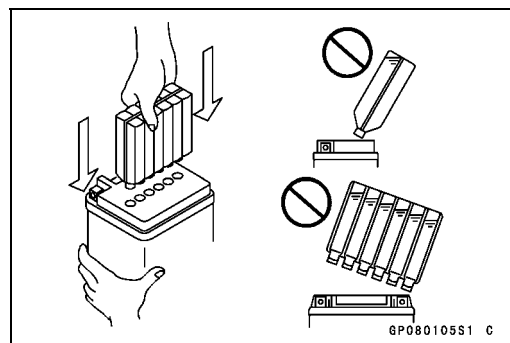

NOTE

○Do not tilt the container as the electrolyte flow may be interrupted.

Battery

- Make sure air bubbles [A] are coming up from all six filler ports.
- Leave the container this way for 5 minutes or longer.

NOTE

○ If no air bubbles are coming up from a filler port, tap [B] the bottom of the container two or three times. Never remove the container from the battery.

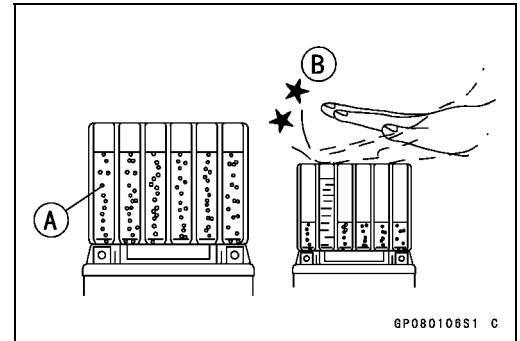

CAUTION

Fill the electrolyte into battery until the container is completely emptied.

- Be certain that all the electrolyte has flowed out.
- Tap the bottom the same way as above if there is any electrolyte left in the container.
- Now pull the container gently out of the battery.
- Let the battery sit for **20** minutes. During this time, the electrolyte permeates the special separators and the gas generated by chemical reaction is released.
- Fit the seal caps [A] tightly into the filler ports until the seal cap is at the same level as the top of the battery.

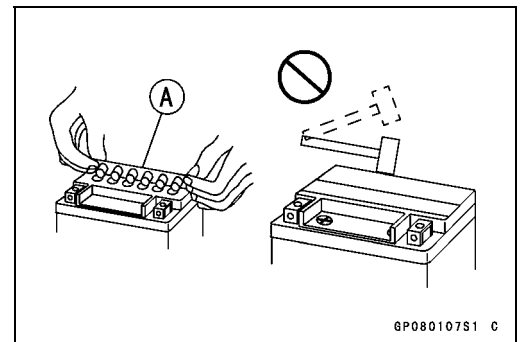

NOTE

○ Do not hammer. Press down evenly with both hands.

CAUTION

Once you install the seal caps after filling the battery, never remove it, nor add any water or electrolyte.

Initial Charge

While a sealed battery can be used after only filling with electrolyte, a battery may not be able to sufficiently move a starter motor to start an engine in the cases shown in the table below, where an initial charge is required before use. However, if a battery shows a terminal voltage of higher than 12.8 V after 10 minutes of filling (Note 1), no initial charge is necessary.

Condition requiring initial charge	Charging method
At low temperatures (lower than 0°C)	0.9 A × 2 ~ 3 hours
Battery has been stored in high temperature and humidity.	
Seal has been removed, or broken - peeling, tear or hole.	
Battery as old as 2 years or more after manufacture. Battery manufacturing date is printed on battery top. Example) <u>12</u> <u>10</u> <u>93</u> <u>T1</u> Day Month Year Mfg. location	0.9 A × 15 ~ 20 hours

Note 1: Terminal voltage-To measure battery terminal voltage, use a digital voltmeter.

Precautions

- 1) No need of topping-up
No topping-up is necessary in this battery until it ends its life under normal use. Forcibly prying off the seal cap to add water is very dangerous. Never do that.
- 2) Refreshing charge
If an engine will not start, a horn sounds weak, or lamps are dim, it indicates the battery has been discharged. Give refresh charge for 5 to 10 hours with charge current shown in the specification (see the this chapter).

15-24 ELECTRICAL SYSTEM

Battery

When a fast charge is inevitably required, do it following precisely the maximum charge current and time conditions indicated on the battery.

CAUTION

This battery is designed to sustain no unusual deterioration if refresh-charged according to the method specified above. However, the battery's performance may be reduced noticeably if charged under conditions other than given above.

Never remove the seal cap during refresh charge.

If by chance an excessive amount of gas is generated due to overcharging, the safety valve operates to keep the battery safe.

- 3) When you do not use the motorcycle for months
Give a refresh charge before you store the motorcycle and store it with the negative cable removed. Give a refresh charge once a month during storage.
- 4) Battery life
If the battery will not start the engine even after several refresh charges, the battery has exceeded its useful life. Replace it. (Provided, however, the vehicle's starting system has no problem.)

⚠ WARNING

Keep the battery away from sparks and open flames during charging, since the battery gives off an explosive gas mixture of hydrogen and oxygen. When using a battery charger, connect the battery to the charger before turning on the charger. This procedure prevents sparks at the battery terminals which could ignite any battery gases.

No fire should be drawn near the battery, or no terminals should have the tightening loosened.

The electrolyte contains sulfuric acid. Be careful not to have it touch your skin or eyes. If touched, wash it off with liberal amount of water. Get medical attention if severe.

Interchange

A sealed battery can fully display its performance only when combined with a proper vehicle electric system. Therefore, replace a sealed battery only on a motorcycle which was originally equipped with a sealed battery.

Be careful, if a sealed battery is installed on a motorcycle which had an ordinary battery as original equipment, the sealed battery's life will be shortened.

Charging Condition Inspection

Battery charging condition can be checked by measuring battery terminal voltage.

- Remove the seats (see Frame chapter).
- Disconnect the battery cables.

CAUTION

Be sure to disconnect the negative (–) cable first.

- Measure the battery terminal voltage.

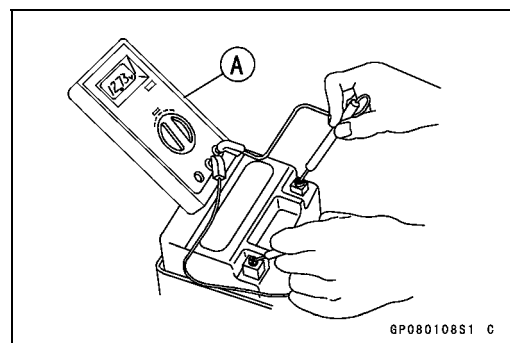

Battery

NOTE

○ Measure with a digital voltmeter [A] which can be read to one decimal place voltage.

★ If the reading is below the specified, refreshing charge is required.

Battery Terminal Voltage

Standard: 12.8 V or more

Refreshing Charge

- Remove the battery [A].
- Do refresh-charge by following method according to the battery terminal voltage.

WARNING

This battery is sealed type. Never remove seal caps [B] even at charging. Never add water. Charge with current and time as stated below.

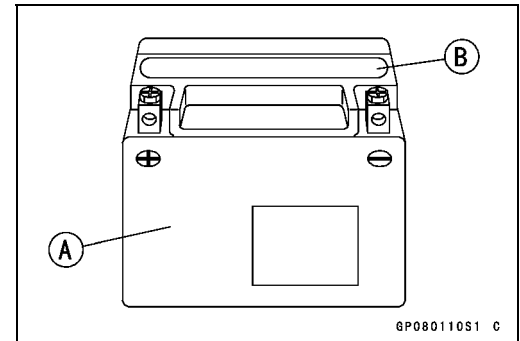
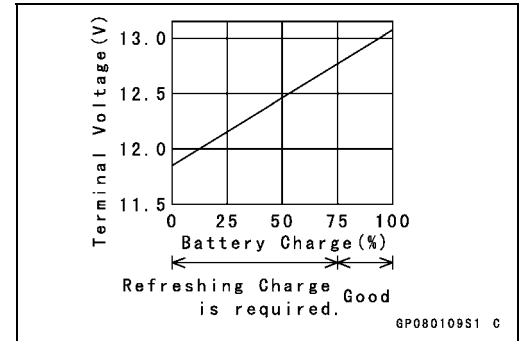

Terminal Voltage: 11.5 ~ less than 12.8 V

Standard Charge

0.9 A × 5 ~ 10 h (see following chart)

Quick Charge

4.0 A × 1.0 h

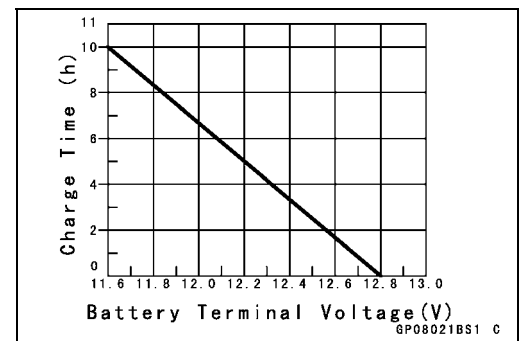

CAUTION

If possible, do not quick charge. If the quick charge is done due to unavoidable circumstances, do standard charge later on.

Terminal Voltage: less than 11.5 V

Charging Method: 0.9 A × 20 h

NOTE

○ If the current does not flow when charging, raise the voltage initially (25 V as maximum), and let down the voltage to charge when the current starts to flow as a yardstick. If ammeter shows no change in current after 5 minutes, you need a new battery. The current, if it can flow into the battery, tends to become excessive. Adjust the voltage as often as possible to keep the current at standard value (0.9 A).

Battery [A]

Battery Charger [B]

Standard Value [C]

Current Starts to flow [D]

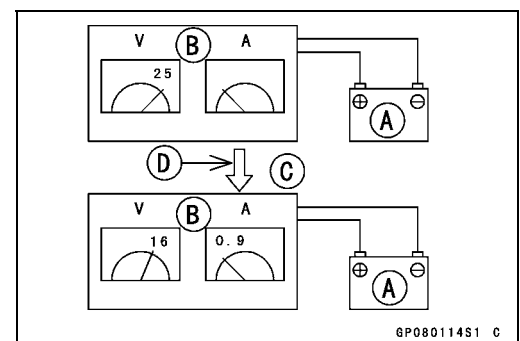

15-26 ELECTRICAL SYSTEM

Battery

- Determine battery condition after refreshing charge.
- Determine the condition of the battery 30 minutes after completion of the charge by measuring the terminal voltage according to the table below.

Criteria	Judgement
12.8 V or higher	Good
12.0 ~ 12.8 V or lower	Charge insufficient → Recharge.
12.0 V or lower	Unserviceable → Replace

Charging System

Alternator Cover Removal

- Remove:
 - Left Lower Fairing (see Frame chapter)
 - Coolant Reserve Tank [A]
 - Fuel Tank (see Fuel System chapter)
 - Alternator Lead Connector [B]
- Place a suitable container under the alternator cover [C], and remove the cover.

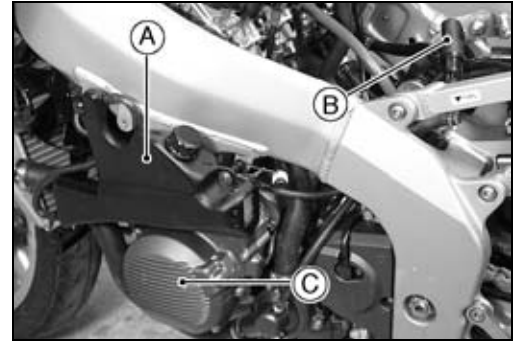

Alternator Cover Installation

- Apply silicone sealant to the alternator lead grommet and crankcase halves mating surface [A] on the front and rear sides of the cover mount.

Sealant - Kawasaki Bond (Silicone Sealant): 56019-120

- Check that knock pins [B] are in place on the crankcase.
- Install a new gasket and the alternator cover.
- Tighten:

Torque - Alternator Cover Bolts: 12 N·m (1.2 kgf·m, 104 in·lb)

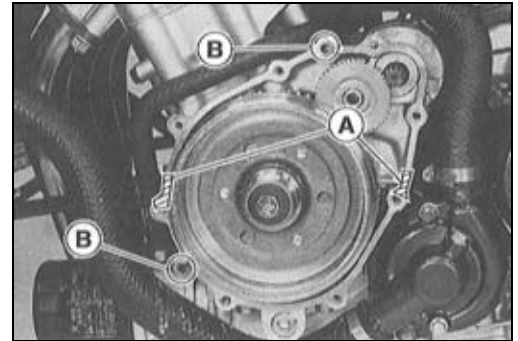

Stator Coil Removal

- Remove:
 - Alternator Cover (see Alternator Cover Removal)
 - Holding Plate Bolts [A] and Plate
 - Alternator Lead Grommet [B]
 - Stator Coil Bolts [C]
- Remove the stator coil [D] from the alternator cover.

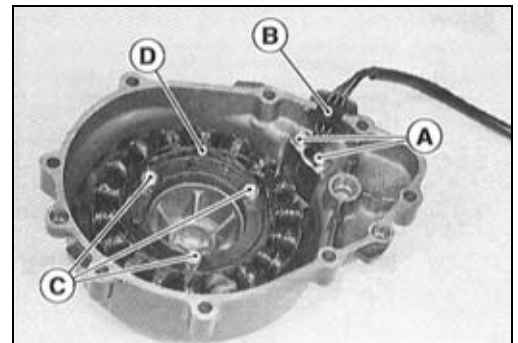

Stator Coil Installation

- Apply a non-permanent locking agent to the threads of the stator coil bolts and tighten them.

Torque - Stator Coil Bolts: 12 N·m (1.2 kgf·m, 104 in·lb)

- Apply silicone sealant to the circumference of the alternator lead grommet, and fit the grommet into the notch of the cover securely.

Sealant - Kawasaki Bond (Silicone Sealant): 56019-120

- Secure the alternator lead with a holding plate, and apply a non-permanent locking agent to the threads of the plate bolts and tighten them.

Torque - Alternator Lead Holding Plate Bolts: 6.9 N·m (0.70 kgf·m, 62 in·lb)

- Install the alternator cover (see Alternator Cover Installation).

15-28 ELECTRICAL SYSTEM

Charging System

Alternator Rotor Removal

- Remove:
 - Alternator Cover (see Alternator Cover Removal)
 - Starter Idle Gear and Shaft
- Wipe oil off the outer circumference of the rotor.
- Hold the alternator rotor steady with the flywheel holder [A], and remove the rotor bolt [B].

Special Tool - Flywheel Holder: 57001-1313

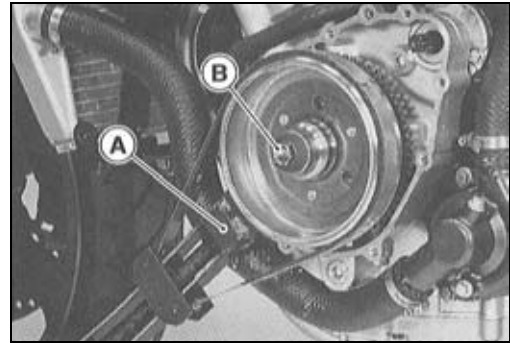

- Using the flywheel puller [A], remove the alternator rotor from the crankshaft.

Special Tools - Flywheel Puller Assembly, M38 × 1.5/M35 × 1.5: 57001-1405

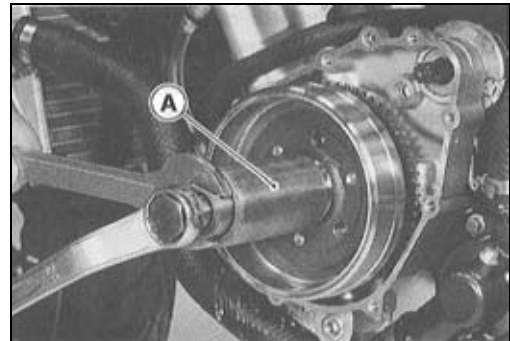

CAUTION

Do not attempt to strike the alternator rotor itself. Striking the rotor can cause the magnets to lose their magnetism.

Alternator Rotor Installation

- Using a cleaning fluid, clean off any oil or dirt on the following portions and dry them with a clean cloth.
 - [A] Crankshaft Tapered Portion
 - [B] Alternator Rotor Tapered Portion
- Apply a thin coat of molybdenum disulfide grease to the crankshaft [C].

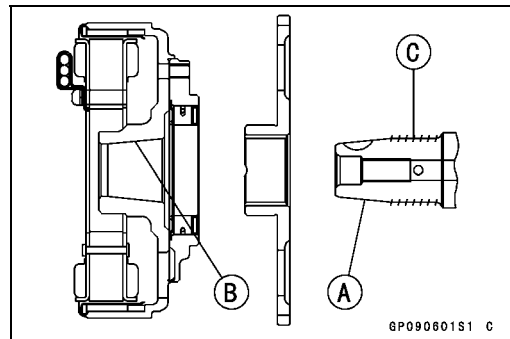

- Install the starter gear [A], and washer [B].
- Again, clean the crankshaft tapered portion [C] and dry there.



- Install the alternator rotor [A] while turning [B] it counter-clockwise.

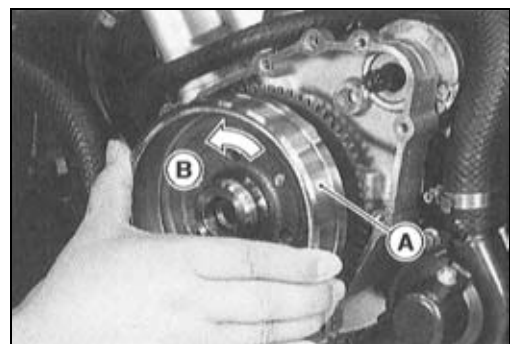

Charging System

- Install the washer [A] so that the chamfer side [B] faces outward.

NOTE

- Confirm the alternator rotor fit or not to the crankshaft before tightening it with specified torque.
 - Install the rotor and tighten it with 70 N·m (7 kgf·m, 52 ft·lb) of torque.
 - Remove the washer and rotor bolt.
 - Check the tightening torque with rotor puller.
 - ★ If the rotor is not pulled out with 20 N·m (2 kgf·m, 15 ft·lb) of drawing torque, it is installed correctly.
 - ★ If the rotor is pulled out with under 20 N·m (2 kgf·m, 15 ft·lb) of drawing torque, clean off any oil dirt or flaw of the crankshaft and rotor tapered portion, and dry them with a clean cloth. Then, confirm that it is not pulled out with above torque.
- Tighten the alternator rotor bolt while holding the alternator rotor steady with the flywheel holder.
- Special Tool - Flywheel Holder: 57001-1313**
- Torque - Alternator Rotor Bolt: 120 N·m (12 kgf·m, 87 ft·lb)**
 - Apply a thin coat of molybdenum disulfide grease to the shaft [A], and install it and starter idle gear [B].
 - Install the alternator cover (see Alternator Cover Installation).

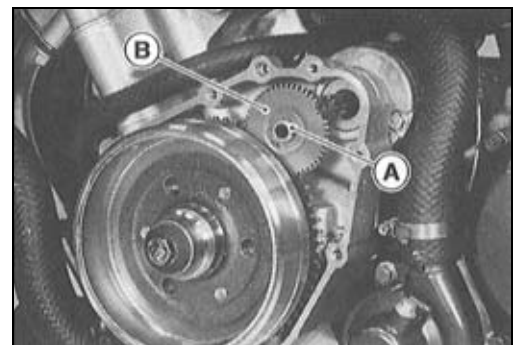
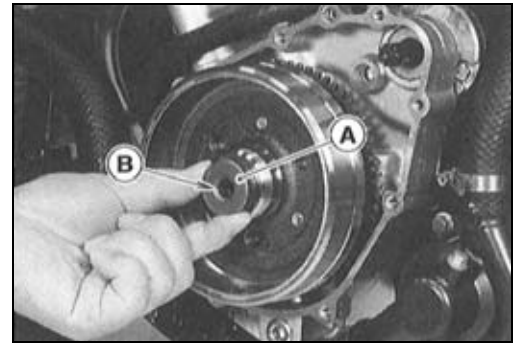

Alternator Inspection

There are three types of alternator failures: short, open (wire burned out), or loss in rotor magnetism. A short or open in one of the coil wires will result in either a low output, or no output at all. A loss in rotor magnetism, which may be caused by dropping or hitting the alternator, by leaving it near an electromagnetic field, or just by aging, will result in low output.

- To check the alternator output voltage, do the following procedures.
- Turn off the ignition switch.
- Remove the fuel tank (see Fuel System chapter).
- Supply fuel to the carburetors with an auxiliary fuel tank.
- Disconnect the alternator lead connector [A].
- Connect the hand tester as shown in the table 1.
- Start the engine, and run it 6,000 rpm 5 minutes.
- Run it at the rpm given in the table 1.
- Note the voltage readings (total 3 measurements).

Table 1 Alternator Output Voltage

Tester Range	Connections		Reading @ 4 000 rpm
	Tester (+) to	Tester (-) to	
250 V AC	One Black lead	Another Black lead	53.5 ~ 72.5 V



15-30 ELECTRICAL SYSTEM

Charging System

- ★ If the output voltage shows the value in the table, the alternator operates properly.
- ★ If the output voltage shows a much higher than the value in the table, the regulator/rectifier is damaged. A much lower reading than that given in the table indicates that the alternator is defective.
- Check the stator coil resistance as follows.
 - Stop the engine.
 - Connect the hand tester as shown in the table 2.
 - Note the readings (total 3 measurement).

Table 2 Stator Coil Resistance

Tester Range	Connections		Reading
	Tester (+) to	Tester (-) to	
× 1 Ω	One Black lead	Another Black lead	0.3 ~ 0.4 Ω

- ★ If there is more resistance than shown in the table, or no hand tester reading (infinity) for any two leads, the stator has an open lead and must be replaced. Much less than this resistance means the stator is shorted, and must be replaced.
- Using the highest resistance range of the hand tester, measure the resistance between each of the black leads and chassis ground.
- ★ Any hand tester reading less than infinity (∞) indicates a short, necessitating stator replacement.
- ★ If the stator coils have normal resistance, but the voltage check showed the alternator to be defective; then the rotor magnets have probably weakened, and the rotor must be replaced.

Special Tool - Hand Tester: 57001-1394

Regulator/Rectifier Inspection

- Remove:
 - Seat Cover (see Frame chapter)
 - Fuel Tank (see fuel System chapter)
 - Connectors [A] (disconnect)
 - Clamp [B]

Bolts [A]
Regulator/Rectifier [B]

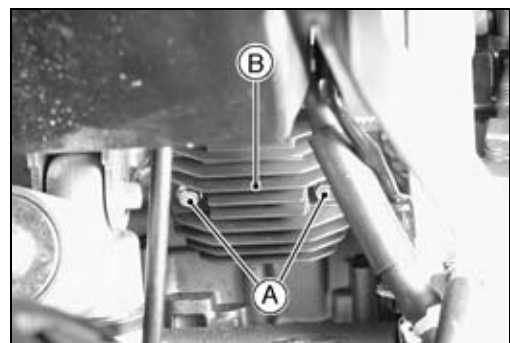
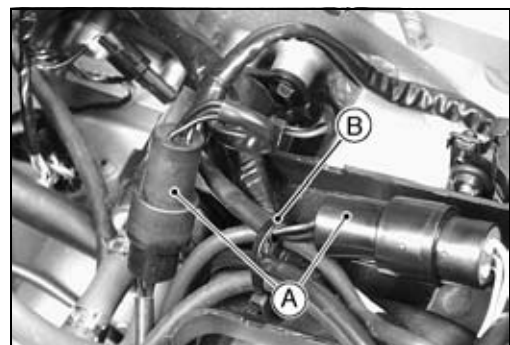

Charging System

Rectifier Circuit Check

- Check the rectifier resistance as follows.
- Disconnect the regulator/rectifier connector.
- Connect the hand tester (special tool) to the regulator/rectifier as shown in the table, and check the resistance in both directions of each diode in the rectifier following the table.
- ★ The resistance should be low in one direction and more than ten times as much in the other direction. If any two leads are low or high in both directions, the rectifier is defective and the regulator/rectifier must be replaced.

NOTE

○ The actual meter reading varies with the meter used and the individual rectifier, but, generally speaking the lower reading should be from zero to one half the scale.

No.	Connections		Reading	Tester Range
	Tester (+)	Tester (-)		
1	BK1	BK/BL	∞	× 10Ω or × 100Ω
2	BK2			
3	BK3			
4	BK1	BK/W	1/2 scale or less	
5	BK2			
6	BK3			
7	BK/BL	BK1	∞	
8		BK2		
9		BK3		
10	BK/W	BK1	∞	
11		BK2		
12		BK3		

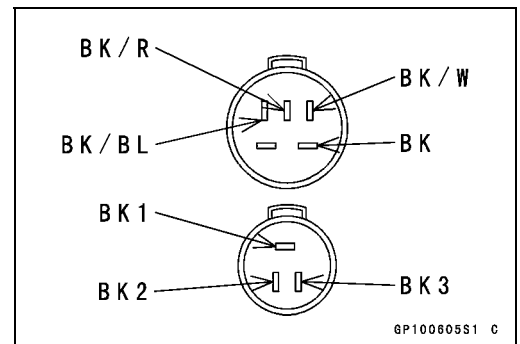

Regulator Circuit Check

To test the regulator out of circuit, use three 12 V batteries and a test light (12 V 3 ~ 6 W bulb in a socket with leads).

CAUTION

The test light works as an indicator and also a current limiter to protect the regulator/rectifier from excessive current. Do not use an ammeter instead of a test light.

15-32 ELECTRICAL SYSTEM

Charging System

- Do the 1st step regulator circuit test.
- Connect the test light and the 12 V battery to the regulator/rectifier as shown.
- Check BK1, BK2, and BK3 terminal respectively.
- ★ If the test light turns on, the regulator/rectifier is defective. Replace it.
- ★ If the test light does not turn on, continue the test.

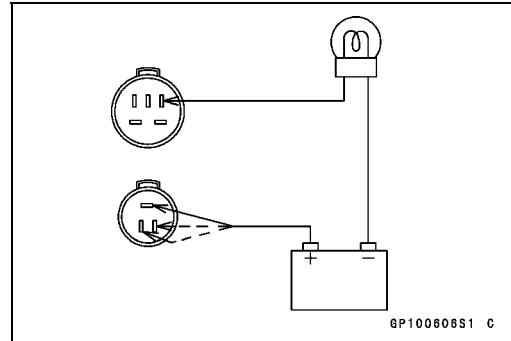

- Do the 2nd step regulator circuit test.
- Connect the test light and the 12 V battery in the same manner as specified in the "1st step regulator circuit test".
- Apply 12 V to the BK/R terminal.
- Check BK1, BK2, and BK3 terminal respectively.
- ★ If the test light turns on, the regulator/rectifier is defective. Replace it.
- ★ If the test light does not turn on, continue the test.

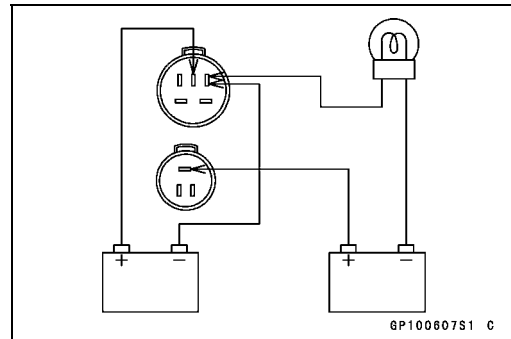

- Do the 3rd step regulator circuit test
- Connect the test light and the 12 V battery in the same manner as specified in the "1st step regulator circuit test".
- Momentarily apply 24 V to the BK/R terminal by adding a 12 V battery.
- Check BK1, BK2, and BK3 terminals respectively.

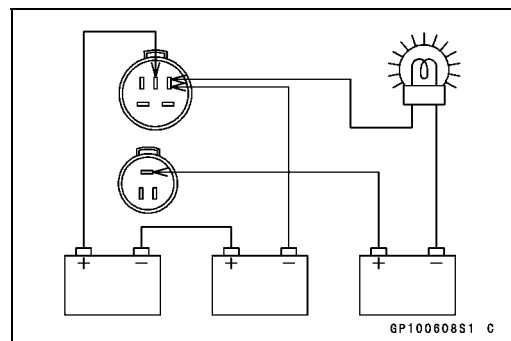

CAUTION

Do not apply more than 24 volts. If more than 24 volts is applied the regulator/rectifier may be damaged. Do not apply 24 V more than a few seconds. If 24 volts is applied for more than a few seconds, the regulator/rectifier may be damaged.

- ★ If the test light did not light when the 24 V was applied momentarily to the BK/R terminal, the regulator/rectifier is defective. Replace it.
- ★ If the regulator/rectifier passes all of the tests described, it may still be defective. If the charging system still does not work properly after checking all of the components and the battery, test the regulator/rectifier by replacing it with a known good unit.

Charging Voltage Inspection

- Check the battery condition (see Battery section).
- Warm up the engine to obtain actual alternator operating conditions.
- Remove the seats (see Frame chapter).
- Check that the ignition switch is turned off, and connect the hand tester [A] as shown in the table.

Special Tool - Hand Tester: 57001-1394

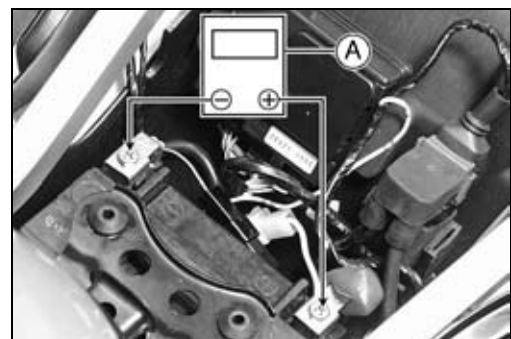

Charging System

- Start the engine, and note the voltage readings at various engine speeds with the headlight turned on and then turned off. (To turn off the headlight of US, Canada, Australia and Malaysia models, disconnect the headlight connector in the upper fairing.) The readings should show nearly battery voltage when the engine speed is low, and, as the engine speed rises, the readings should also rise. But they must be kept under the specified voltage.

Charging Voltage

Tester Range	Connections		Reading
	Tester (+) to	Tester (-) to	
25 V DC	Battery (+)	Battery (-)	14.2 ~ 15.2 V

- Turn off the ignition switch to stop the engine, and disconnect the hand tester.
- ★ If the charging voltage is kept between the values given in the table, the charging system is considered to be working normally.
- ★ If the charging voltage is much higher than the values specified in the table, the regulator/rectifier is defective or the regulator/rectifier leads are loose or open.
- ★ If the charging voltage does not rise as the engine speed increases, then the regulator/rectifier is defective or the alternator output is insufficient for the loads. Check the alternator and regulator/rectifier to determine which part is defective.

15-34 ELECTRICAL SYSTEM

Charging System

Charging System Circuit

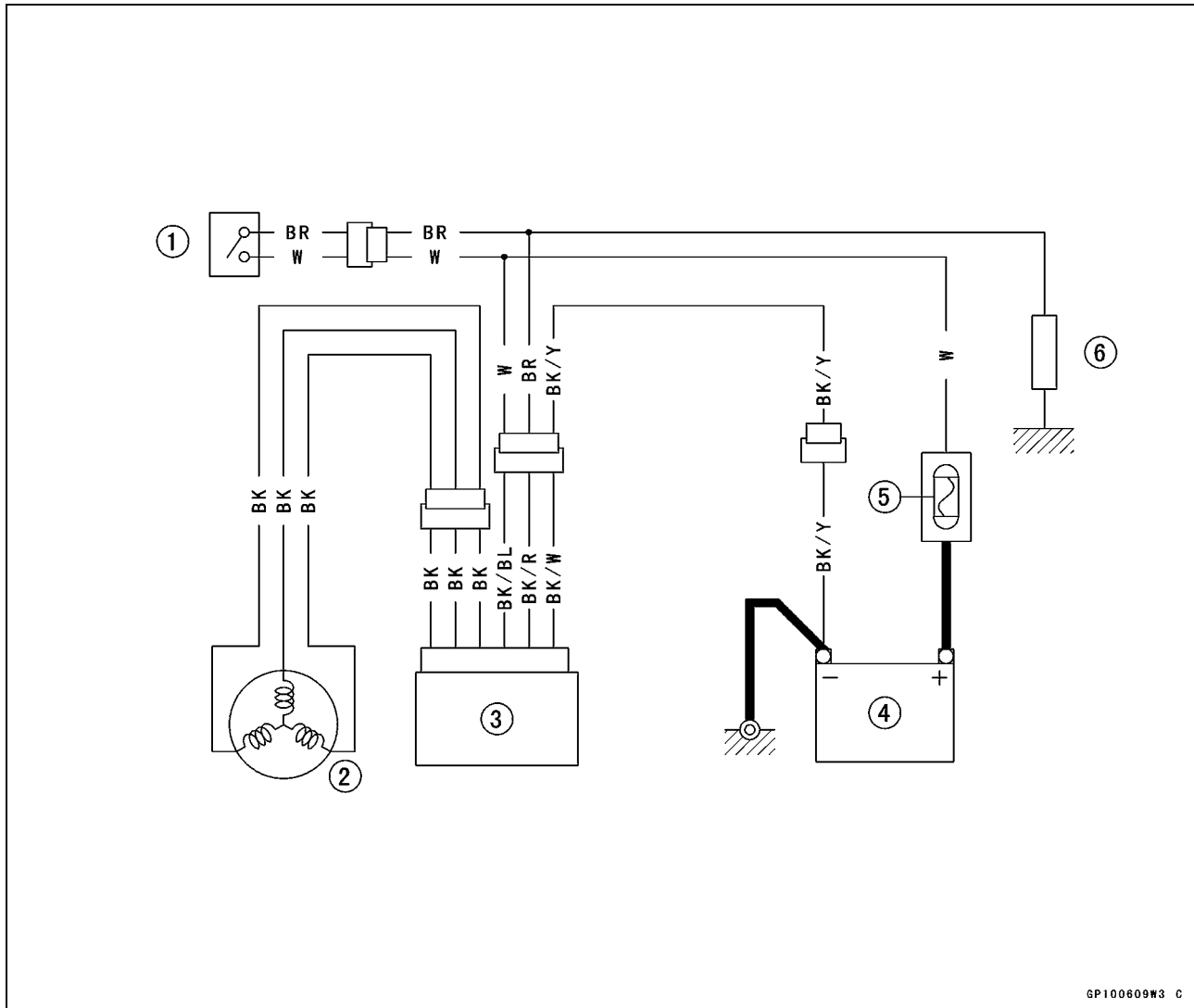

GP100609W3 C

1. Ignition Switch
2. Alternator
3. Regulator/Rectifier
4. Battery
5. Main Fuse 30 A
6. Load

Ignition System

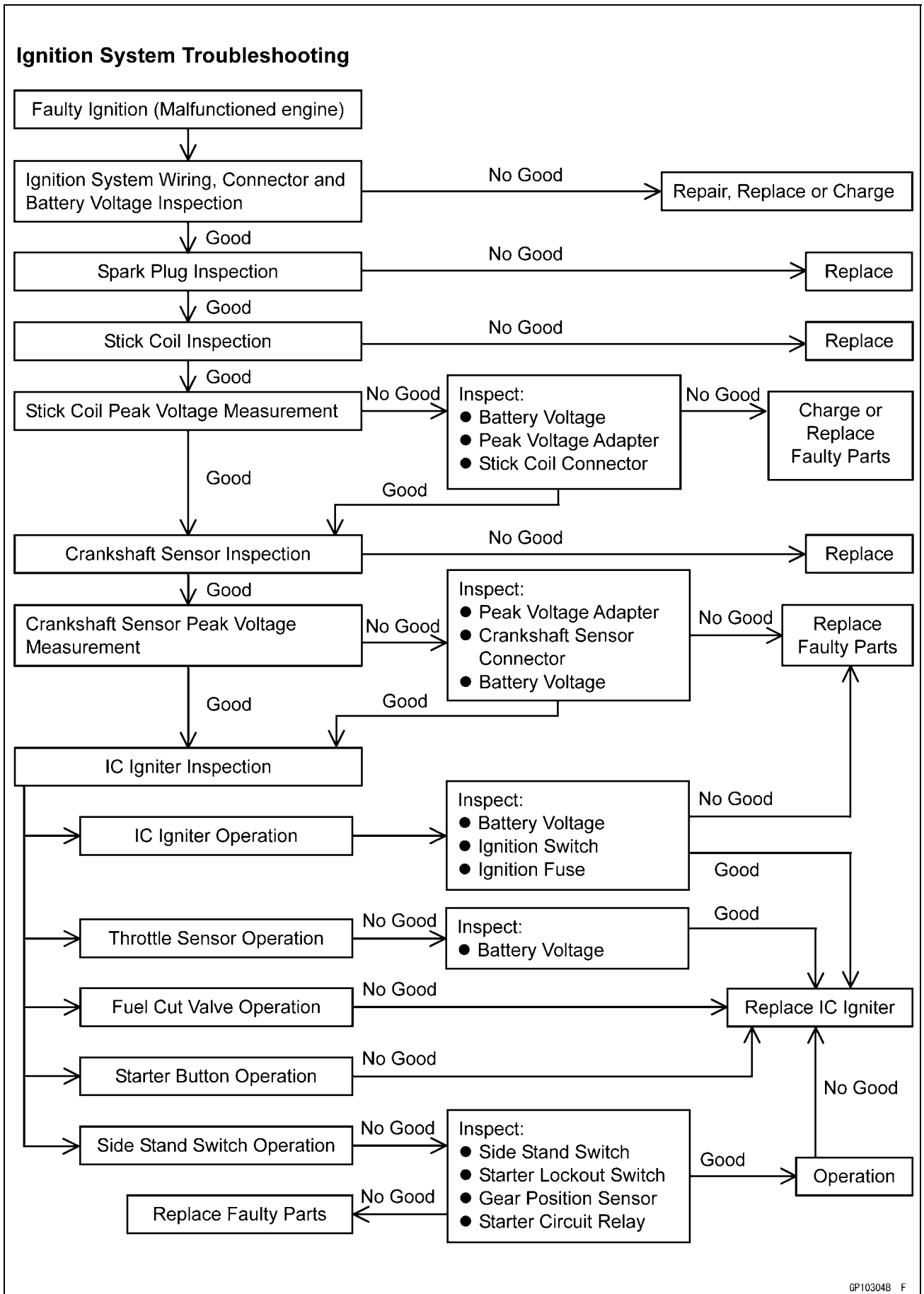

15-36 ELECTRICAL SYSTEM

Ignition System

⚠ WARNING

The ignition system produces extremely high voltage. Do not touch the spark plugs or stick coils while the engine is running, or you could receive a severe electrical shock.

CAUTION

Do not disconnect the battery leads or any other electrical connections when the ignition switch is on, or while the engine is running. This is to prevent IC igniter damage.

Do not install the battery backwards. The negative side is grounded. This is to prevent damage to the diodes and IC igniter.

Crankshaft Sensor Removal

- Remove:
 - Fuel Tank (see Fuel System chapter)
 - Right Lower Fairing (see Frame chapter)
 - Water Temperature Sensor Connector [A]
 - Crankshaft Sensor Lead Connector [B]
 - Side Stand Switch Lead Connector [C]

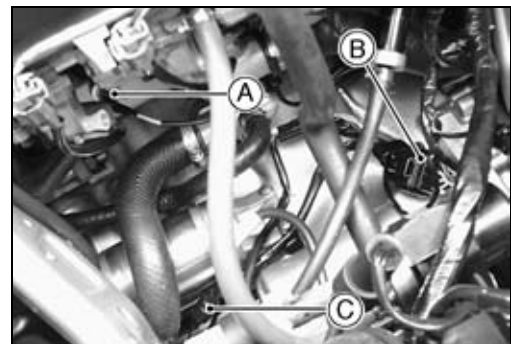

Neutral Switch Lead Connector [A]



Crankshaft Sensor Cover
Oil Pressure Switch Terminal [A]

- Remove the crankshaft sensor [B] by taking off the crankshaft sensor bolts [C].

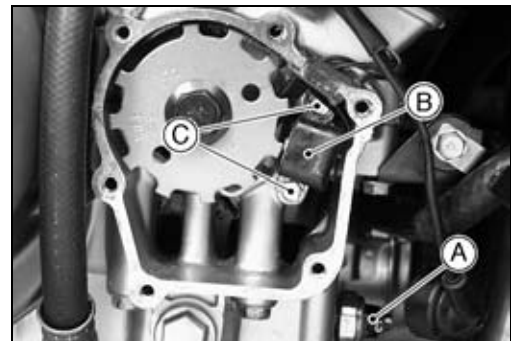

Ignition System

Crankshaft Sensor Installation

- Route the crankshaft sensor lead correctly (see Cable, Wire, and Hose Routing in General/Information chapter).
- Tighten:

Torque - Crankshaft Sensor Bolts: 5.9 N·m (0.60 kgf·m, 52 in·lb)

- Apply silicone sealant [A] to the crankshaft sensor lead grommet and crankcase halves mating surface on the front and rear sides of the crankshaft sensor cover mount.

Sealant - Kawasaki Bond (Silicone Sealant): 56019-120

- Apply a non-permanent locking agent to the threads of the crankshaft sensor cover bolt [A].
- Install the clamps [B] and tighten the crankshaft sensor cover bolts.

Torque - Crankshaft Sensor Cover Bolts: 11 N·m (1.1 kgf·m, 95 in·lb)

- Install the oil pressure switch terminal and tighten the terminal bolt.

Torque - Oil Pressure Switch Terminal Bolt: 1.5 N·m (0.15 kgf·m, 13 in·lb)

- Apply grease to the terminal.
- Install the other remove parts.

Crankshaft Sensor Inspection

- Remove:
 - Fuel Tank (see Fuel System chapter)
 - Crankshaft Sensor Lead Connector [A]
- Set the hand tester [B] to the $\times 100 \Omega$ range and using auxiliary wire, connect it to the black lead [C] and black/yellow lead [D] in the connector [A].

Special Tool - Hand Tester: 57001-1394

- ★ If there is more resistance than the specified value, the coil has an open lead and must be replaced. Much less than this resistance means the coil is shorted, and must be replaced.

Crankshaft Sensor Resistance: 452 ~ 462 Ω

- Using the highest resistance range of the tester, measure the resistance between the crankshaft sensor leads and chassis ground.
- ★ Any tester reading less than infinity (∞) indicates a short, it is necessary to replace the crankshaft sensor assembly.

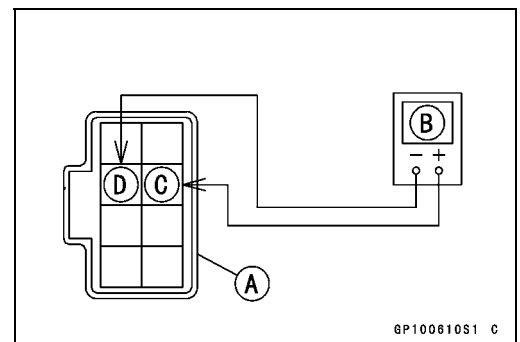
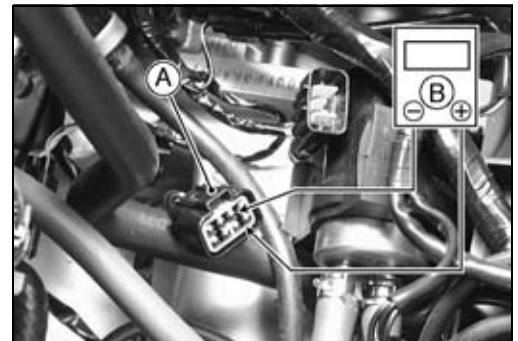
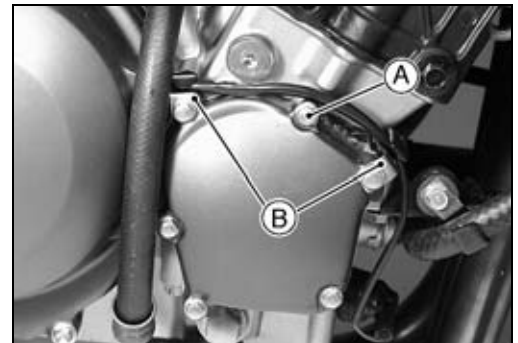
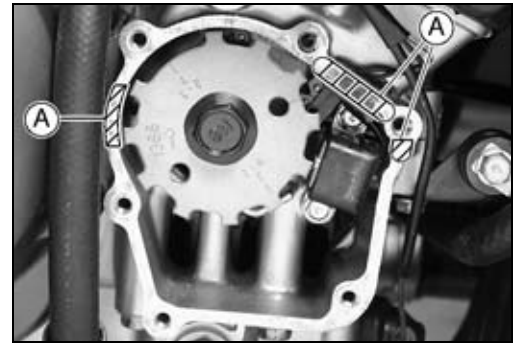

15-38 ELECTRICAL SYSTEM

Ignition System

Crankshaft Sensor Peak Voltage Measurement

- Remove:
 - Fuel Tank (see Fuel System chapter)
 - Crankshaft Sensor Lead Connector
- Set the Hand Tester [B] to the $\times 25$ V DC range, and connect it to the peak voltage adapter [E] as shown in the diagram.
- Using two auxiliary wires, connect the black lead (-) of the adapter to black/yellow lead [D] and red lead (+) to black lead [C] in the crankshaft sensor connection [A].
- Turn the ignition switch and engine stop switch on.
- Grasp the clutch lever and pushing the starter button, turn the engine 4 ~ 5 seconds with the transmission gear in neutral to measure the crankshaft sensor peak voltage.
- Repeat the measurement 5 or more times.

Crankshaft Sensor Peak Voltage

Standard: 3.8 V or more

Special Tool - Hand Tester: 57001-1394

Peak Voltage Adapter: 57001-1415

Type: KEK-54-9-B

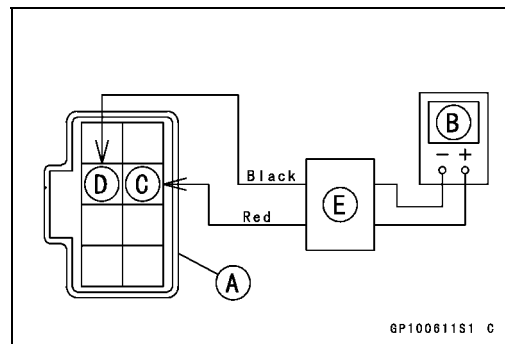

Stick Coil (Ignition Coil together with Spark Plug Cap) Removal

- Remove the air cleaner housing (see Fuel System chapter).
- Disconnect the stick coil connectors [A].
- Pull the stick coils [B] off the spark plugs.

CAUTION

Do not pry the connector part of the coil while removing the coil.

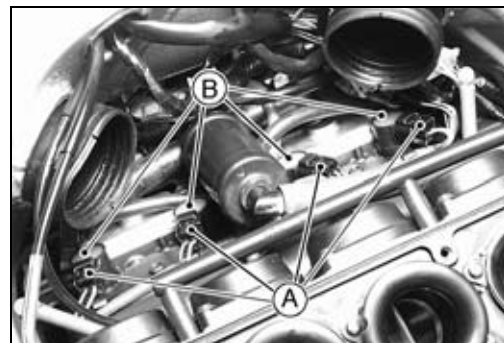

Stick Coil (Ignition Coil together with Spark Plug Cap) Installation

- Install the coil using the following steps.
- Insert the coil as shown being careful of the coil head [A] direction.
- Connect the connectors [B].
- Stick coil connectors angle [C]: about 45°

CAUTION

Do not tap the coil head while installing the coil.

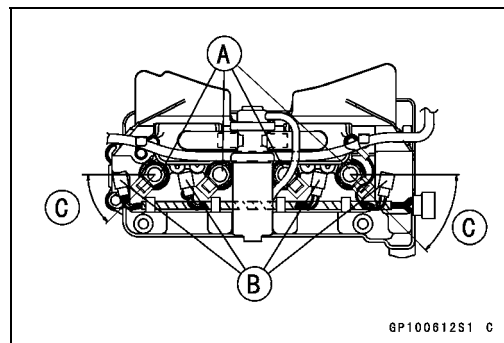

Ignition System

Stick Coil (Ignition Coil together with Spark Plug Cap) Inspection

- Remove the stick coils (see this chapter).
- Measure the primary winding resistance [A] as follows.
 - Connect the hand tester between the coil terminals.
 - Set the tester to the $\times 1 \Omega$ range, and read the tester.
- Measure the secondary winding resistance [B] as follows.
 - Connect the tester between the plug terminal and (-) coil terminal.
 - Set the tester to the $\times 1 \text{ k}\Omega$ range and read the tester.

Ignition Coil Winding Resistance

Primary Windings:	1.2 ~ 1.6 Ω
Secondary Windings:	8.5 ~ 11.5 k Ω

★ If the tester does not read as specified, replace the coil.

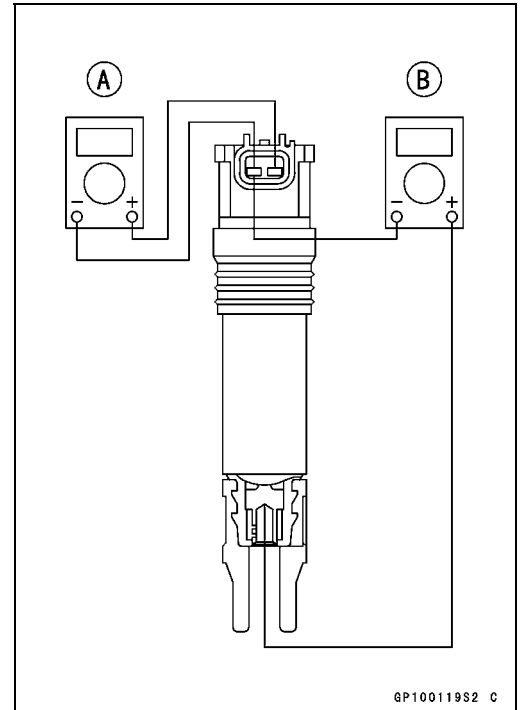

Stick Coil Primary Peak Voltage Measurement

NOTE

○ Be sure the battery is fully charged.

- Remove the stick coils (see this chapter), but do not remove the spark plugs.
- Measure the primary peak voltage as follows.
 - Install the new spark plug [E] into each stick coil [D], and ground them onto the engine.
 - Connect the peak voltage adapter [B] into the hand tester [A] which is set to the $\times 250 \text{ V DC}$ range.
 - Connect the adapter to the lead wire-peak voltage adapter [C] which is connected between the stick coil connector and stick coil.

F: IC igniter

G: Battery

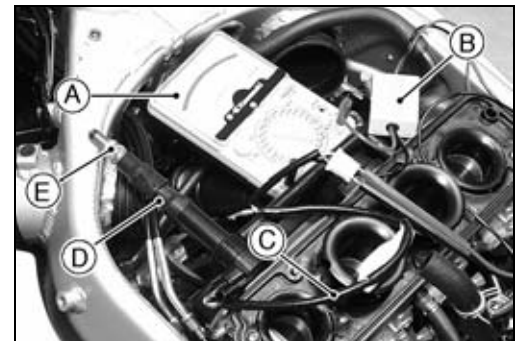

Special Tools - Hand Tester: 57001-1394

Lead Wire - Peak Voltage Adapter: 57001-1449

Peak Voltage Adapter: 57001-1415

Type: KEK-54-9-B

Primary Lead Connection

Adapter (R, +) to lead wire-peak voltage adapter (W)

Adapter (BK, -) to lead wire-peak voltage adapter (R)

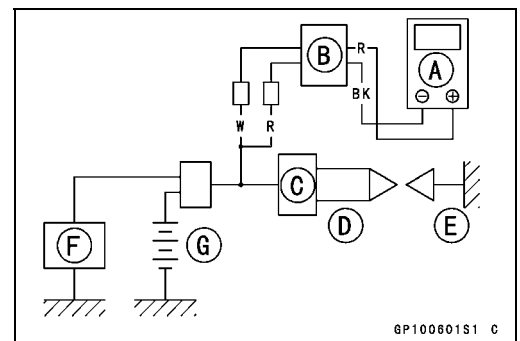

15-40 ELECTRICAL SYSTEM

Ignition System

⚠ WARNING

To avoid extremely high voltage shocks, do not touch the spark plugs or tester connections.

- Turn the ignition switch and the engine stop switch ON.
- Pushing the starter button, turn the engine 4 ~ 5 seconds with the transmission in neutral to measure the primary peak voltage.
- Repeat the measurements 5 times for one stick coil.

Stick Coil Primary Peak Voltage

Standard: 92 V or more

- Repeat the test for the other stick coil.
- ★ If the reading is less than the specified value, check the following.
 - Stick Coils (see Stick Coil Inspection)
 - Crankshaft Sensor (see Crankshaft Sensor Inspection)
 - IC Igniter (see IC Igniter Inspection)

Spark Plug Removal

- Remove:
 - Air Cleaner Housing (see Fuel System chapter)
 - Stick Coils
 - Remove the spark plugs using the 16 mm plug wrench.
- Owner's Tool - Spark Plug Wrench, 16 mm: 92110-1146**

Spark Plug Installation

- Insert the spark plug vertically into the plug hole with the plug [A] installed in the plug wrench [B].
- Owner's Tool - Spark Plug Wrench, 16 mm: 92110-1146**
- Tighten:
 - Torque - Spark Plugs: 13 N·m (1.3 kgf·m, 113 in·lb)**
 - Fit the stick coils securely.



Spark Plug Cleaning and Inspection

- Remove the spark plug, and visually inspect.
- Clean the spark plug, preferably in a sandblasting device, and then clean off any abrasive particles. The plug may also be cleaned using a high flash-point solvent and a wire brush or other suitable tool.
- ★ If the spark plug electrodes are corroded or damaged, or if the insulator is cracked, replace the plug. Use the standard spark plug or its equivalent.

Ignition System

Spark Plug Gap Inspection

- Measure the gap [A] with a wire-type thickness gauge.
- ★ If the gap is incorrect, carefully bend the side electrode [B] with a suitable tool to obtain the correct gap.

Spark Plug Gap: 0.7 ~ 0.8 mm (0.028 ~ 0.031 in.)

CAUTION

Use only the recommended spark plugs (special marks ^{NGK}_R). These spark plugs have special marks [C] on the insulator, as shown. Other spark plugs will wear prematurely.

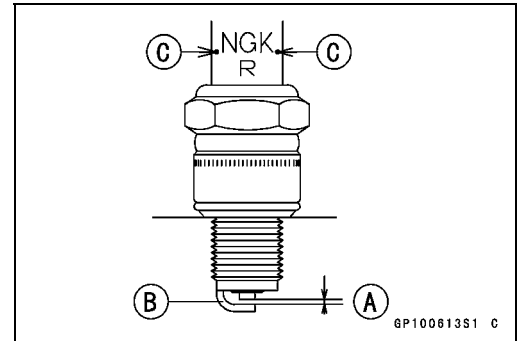

IC Igniter Inspection

CAUTION

When inspecting the IC igniter [A], observe the following to avoid damage to the IC igniter.
Do not disconnect the IC igniter with the ignition switch on. This may damage the IC igniter.
Do not disconnect the battery leads while the engine is running. This may damage the IC igniter.

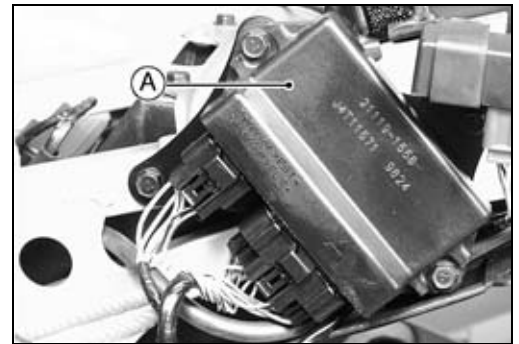

IC Igniter Operation Check

- Remove the seats (see Frame chapter).
- Disconnect the IC igniter left side connector [A].



- Set the Hand Tester [B] to the × 25 V DC range, and using two auxiliary wires, connect it to the connector come from harness side as follows.

Tester (+) terminal [C] → BR/W lead

Tester (-) terminal [D] → BK/Y lead

Special Tools - Hand Tester: 57001-1394

Needle Adapter Set: 57001-1457

- Turn the ignition switch on, and read the voltage.

IC Igniter Operation Voltage: Battery Voltage

- ★ If the tester reading is not specified one, check the battery voltage, ignition switch and ignition fuse.

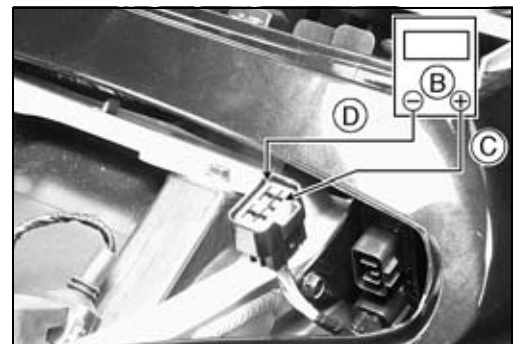

15-42 ELECTRICAL SYSTEM

Ignition System

Throttle Sensor Operation Check

- Remove the fuel tank (see fuel System chapter).
- Disconnect the throttle sensor lead connector.
- Connect the adapter [A] between the connectors [B].

Special Tool - Throttle Sensor Setting Adapter: 57001-1521

- Set the Hand Tester [E] to the $\times 10$ V DC range, and connect it to the adapter as follows.

Hand Tester (+) Terminal \rightarrow BL Lead [C]

Hand Tester (-) Terminal \rightarrow BK/BL Lead [D]

Special Tools - Hand Tester: 57001-1394

Needle Adapter Set: 57001-1457

- Turn the ignition switch on, and read the voltage.

Throttle Sensor Voltage: approx. 5 V

- ★ If the voltage is out of specified one extremely, check the Battery Voltage. If the Battery Voltage is correct, replace the IC igniter.

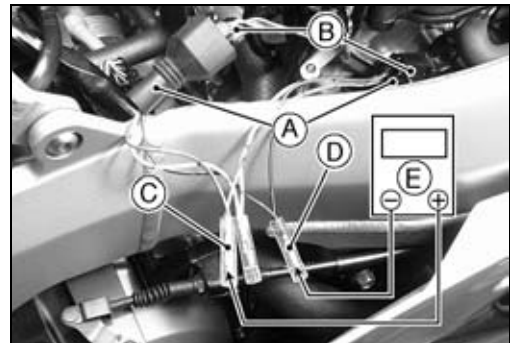

Fuel Cut Valve Operation Check

- Remove the fuel tank (see Fuel System chapter).
- Set the Hand Tester [A] to the $\times 25$ V DC range, and connect it to the each fuel cut valve connector [B] as follows.

Hand Tester (+) Terminal [C] \rightarrow BR/BK Lead

Hand Tester (-) Terminal [D] \rightarrow R or O/G or O/BK or LG/BK Lead

Special Tool - Hand Tester: 57001-1394

- Remove the each ignition coil at each valve test.
- Turn the ignition switch on, and push the starter button.
- Read the voltage at the moment.
- ★ If the tester reading is approximately battery voltage, it is correct. If the voltage is not read, replace the IC igniter.

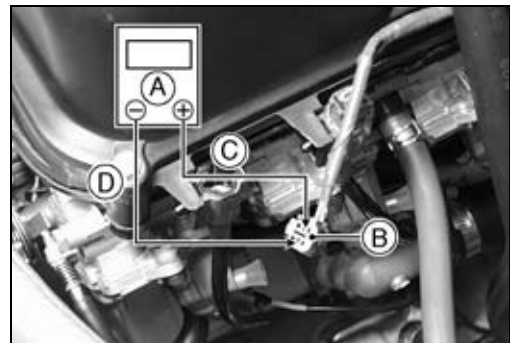

Starter Button Operation Check

- Remove the seats (see Frame chapter).
- Set the Hand Tester [A] to the $\times 10$ V DC range, connect it to the junction box [B] lead as follows.

Hand Tester (+) Terminal [C] \rightarrow BK/R Lead

Hand Tester (-) Terminal [D] \rightarrow Frame Ground

Special Tools - Hand Tester: 57001-1394

Needle Adapter Set: 57001-1457

- Turn the ignition switch on and push the starter button.
- Read the voltage.

Starter Button Voltage: 8 V or more

- ★ If the tester reading is not specified one, replace the IC igniter.

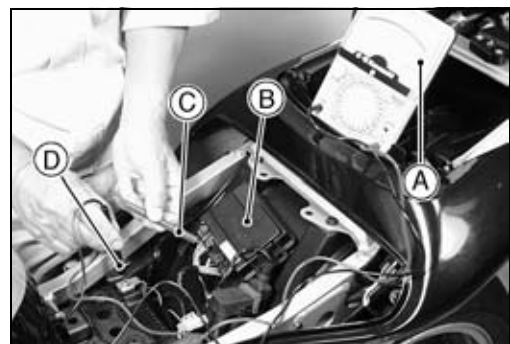

Ignition System

Side Stand Switch Operation Check

- Remove the seats (see Frame chapter).
- Change the transmission gear to the first position and set the side stand to "ON" position.
- Set the Hand Tester [A] to the $\times 25$ V DC range, and connect it to the junction box [B] lead as follows.

Hand Tester (+) Terminal [C] → G/BK Lead

Hand Tester (-) Terminal [D] → Frame Ground

Special Tools - Hand Tester: 57001-1394

Needle Adapter Set: 57001-1457

- Turn the ignition switch on and push the starter button.
- Read the voltage.

Side Stand Switch Operation Voltage: 6 ~ 13.4 V

★ If the tester reading is not specified one, check the side stand switch, starter lock out switch, gear position sensor and starter circuit relay.

★ If the tester reading is correct, check the following.

- Grasp the clutch lever, and start the engine.
- Side stand - "ON" position, transmission gear-first position
- Release the clutch lever slowly.
- ★ If the engine does not stop after releasing the clutch lever fully, the IC igniter is defective.

NOTE

○ Some inspections as to the IC igniter are operated, but the cause of troubles may be not able to clear enoughly. If the cause of troubles are not cleared in described inspections, replace the IC igniter with a new one.

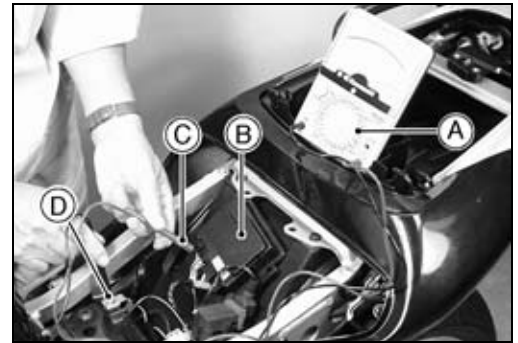

CAUTION

Use only Hand Tester 57001-1394 for this test. A tester other than the Kawasaki Hand Tester may show different readings.

If a megger or a meter with a large-capacity battery is used, the IC igniter will be damaged.

15-44 ELECTRICAL SYSTEM

Ignition System

CDI Unit Troubleshooting

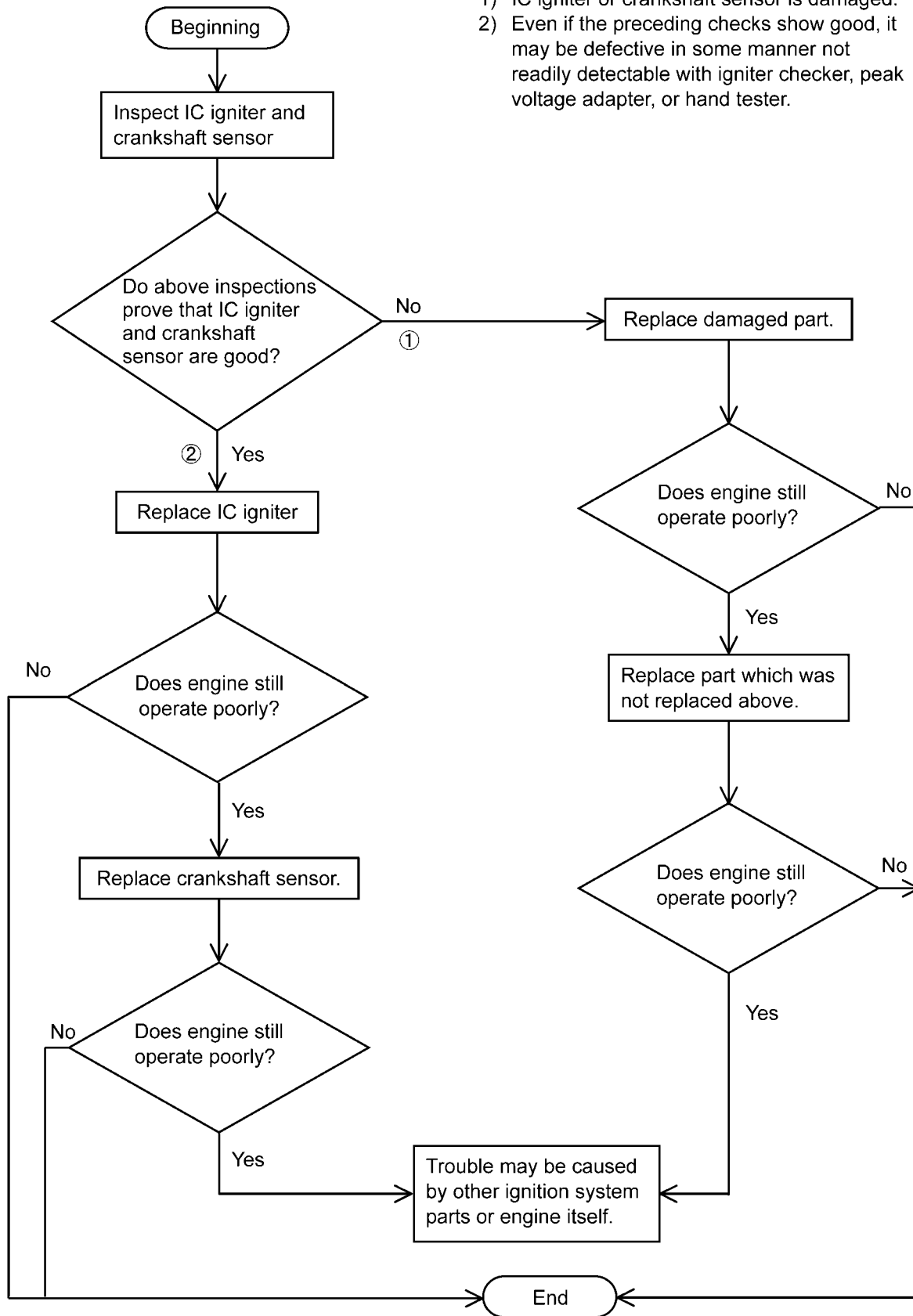

15-46 ELECTRICAL SYSTEM

Electric Starter System

Starter Motor Removal

- Remove the fuel tank (see Fuel System chapter).
- Slide back the rubber cap.
- Remove the starter motor terminal nut [A] and the mounting bolts [B].
- Pull out the starter motor [C].

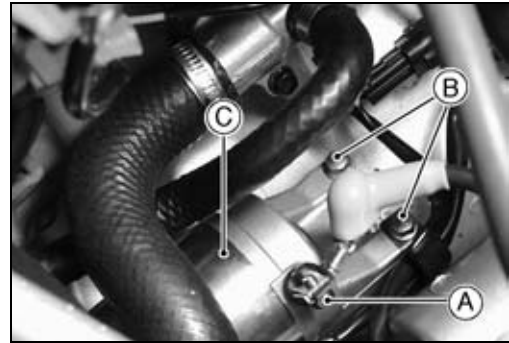

Starter Motor Installation

CAUTION

Do not tap the starter motor shaft or body. Tapping the shaft or body could damage the motor.

- When installing the starter motor, clean the starter motor legs [A] and crankcase [B] where the starter motor is grounded.
- Replace the O-ring [A] with a new one.
- Apply grease to the O-ring.
- Tighten:
Torque - Starter Motor Mounting Bolts: 12 N·m (1.2 kgf·m, 104 in·lb)

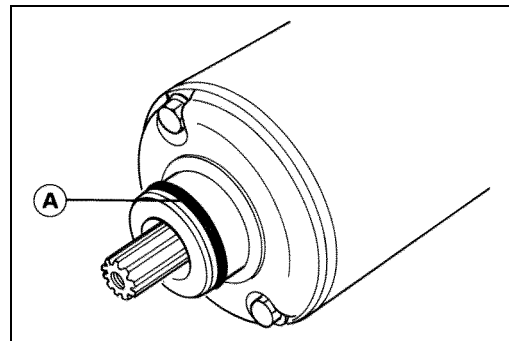
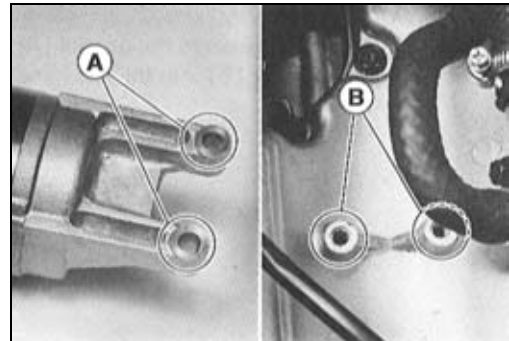

Starter Motor Disassembly

- Take off the starter motor through bolts [A] and remove both end covers [B] and pull the armature out of the yoke [C].

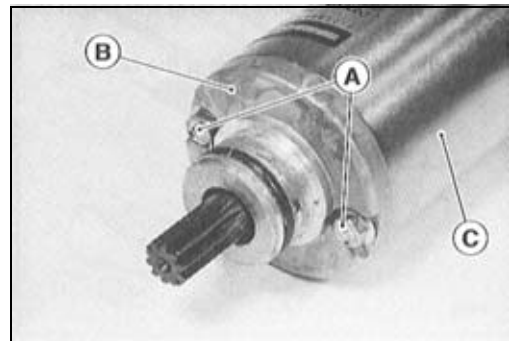

- Remove:
Brush Springs
Brush Holder Plate Screw [A]
Negative Brushes [B]
Brush Holder Plate [C]

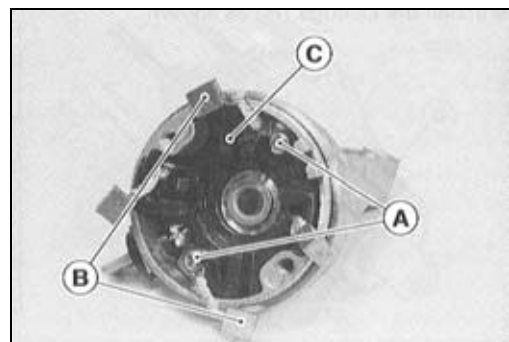

Electric Starter System

- Unsolder the terminal [A] on the positive brush plate and remove it.

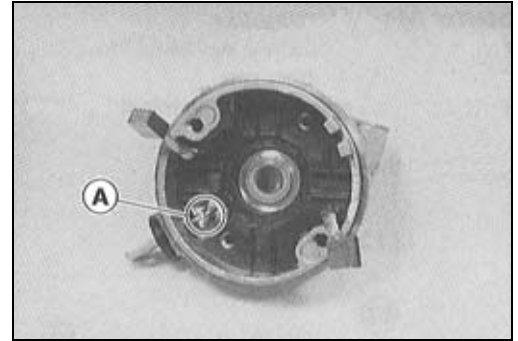

Starter Motor Assembly

- Apply a thin coat of grease to the oil seal [A].
- Fit the toothed washer [B] into the left-hand end cover.

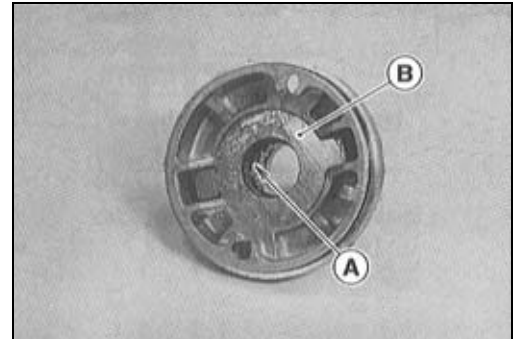

- Install the positive brush plate [A] in the right-hand end cover [B] and solder the terminals [C].

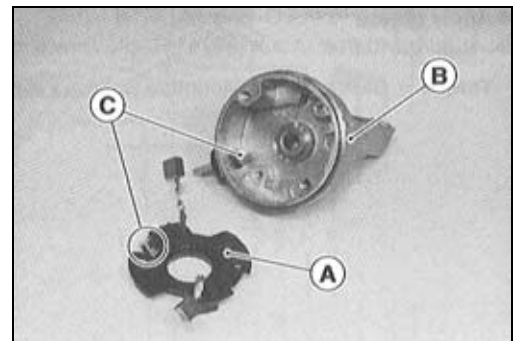

- Press the springs and holding the brush leads with suitable clips [A] as shown.
- Put the armature [B] among the brushes.

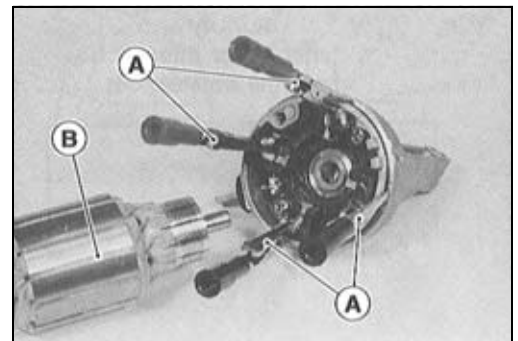

- Install the O-rings [A] as shown.

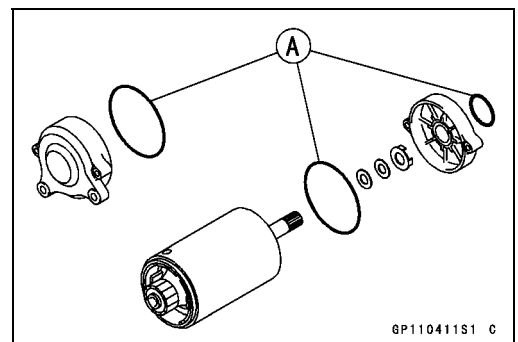

15-48 ELECTRICAL SYSTEM

Electric Starter System

- Align the groove [A] in the right-hand end cover and the mark [B] on the yoke.

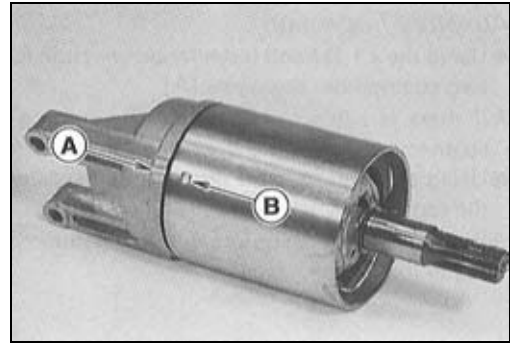

- Align the tongue [A] on the left-hand end cover and the terminal [B] on the right-hand end cover.

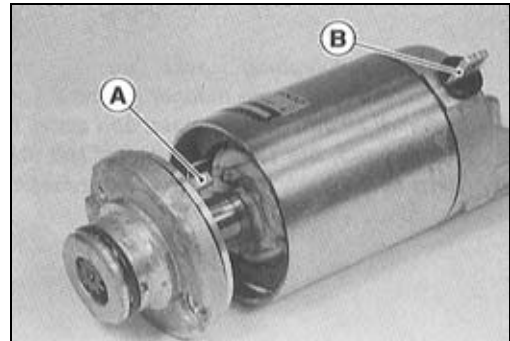

Brush Inspection

- Measure the length [A] of each brush.
- ★ If any is worn down to the service limit, replace all brushes.

Starter Motor Brush Length

Standard:	7 mm (0.28 in.)
Service Limit:	3.5 mm (0.14 in.)

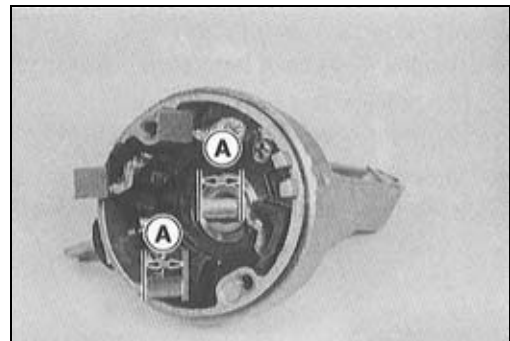

Commutator Cleaning and Inspection

- Smooth the commutator surface [A] if necessary with fine emery cloth [B], and clean out the grooves.

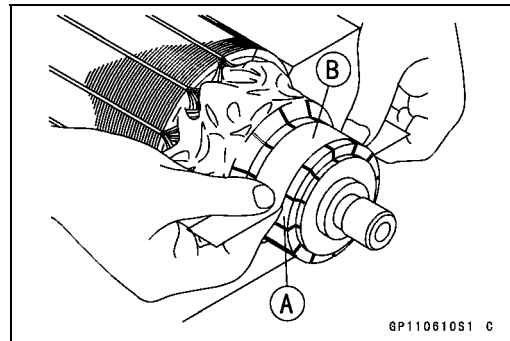

- Measure the diameter [A] of the commutator [B].
- ★ If the commutator diameter is less than the service limit, replace the starter motor with a new one .

Commutator Diameter

Standard:	24 mm (0.94 in.)
Service Limit:	23 mm (0.91 in.)

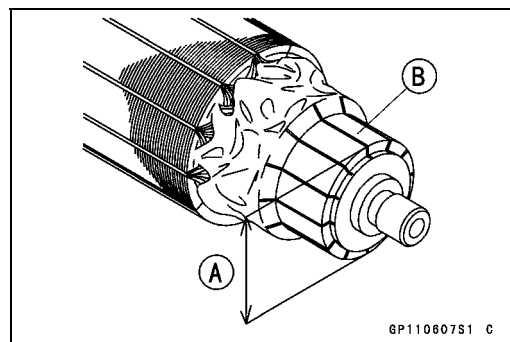

Electric Starter System

Armature Inspection

- Using the $\times 1 \Omega$ hand tester range, measure the resistance between any two commutator segments [A].

Special Tool - Hand Tester: 57001-1394

- ★ If there is a high resistance or no reading (∞) between any two segments, a winding is open and the starter motor must be replaced.
- Using the highest hand tester range, measure the resistance between the segments and the shaft [B].
- ★ If there is any reading at all, the armature has a short and the starter motor must be replaced.

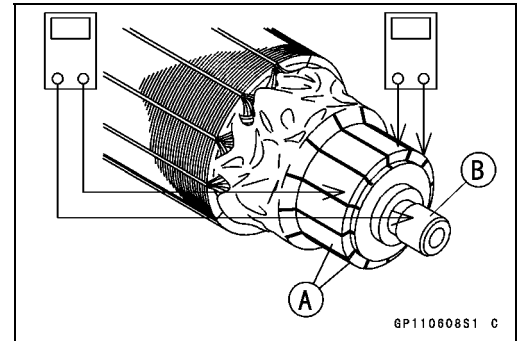

NOTE

○ Even if the foregoing checks show the armature to be good, it may be defective in some manner not readily detectable with the hand tester. If all other starter motor and starter motor circuit components check good, but the starter motor still does not turn over or only turns over weakly, replace the starter motor with a new one.

Brush Lead Inspection

- Using the $\times 1 \Omega$ hand tester range, measure the resistance as shown.

[A] Terminal Bolt and Positive Brush

[B] Right-hand End Cover and Negative Brush

Special Tool - Hand Tester: 57001-1394

- ★ If there is not close to zero ohms, the brush lead has an open. Replace the positive brush assembly and/or the negative brush subassembly.

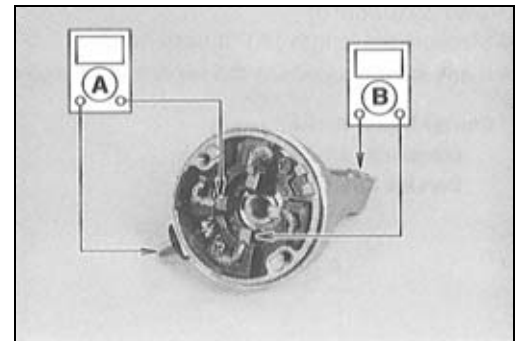

Right-hand End Cover Assembly Inspection

- Using the highest hand tester range, measure the resistance as shown.

[A] Terminal and Right-hand End Cover

Special Tool - Hand Tester: 57001-1394

- ★ If there is any reading, the right-hand end cover assembly have a short. Replace the right-hand end cover assembly.

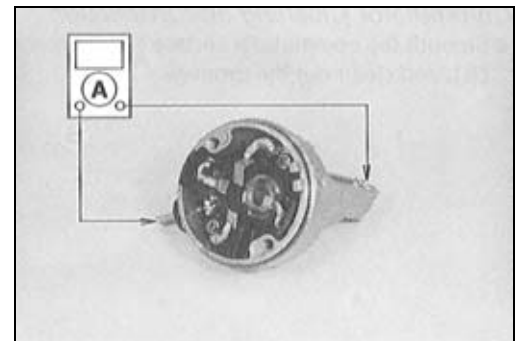

Starter Relay Inspection

- Remove the seats.
- Remove the starter relay.
- Connect the hand tester [A] and 12 V battery [B] to the starter relay [C] as shown.

Special Tool - Hand Tester: 57001-1394

- ★ If the relay does not work as specified, the relay is defective. Replace the relay.

Testing Relay

Tester Range: $\times 1 \Omega$ range

Criteria: When battery is connected $\rightarrow 0 \Omega$

When battery is disconnected $\rightarrow \infty \Omega$

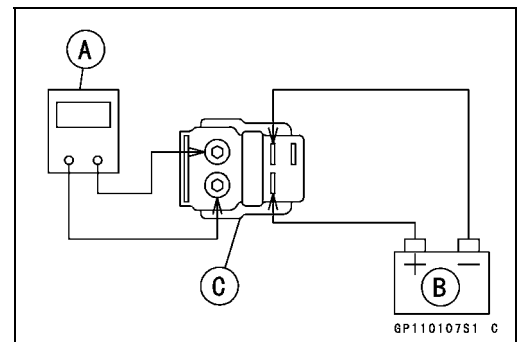

Lighting System

The US, Canada, Australia, and Malaysia models adopt the daylight system and have a headlight relay in the junction box. In these models, the headlight does not go on when the ignition switch and the engine stop switch are first turned on. The headlight comes on after the starter button is released and stays on until the ignition switch is turned off. The headlight will go out momentarily whenever the starter button is pressed and come back on when the button is released.

Headlight Beam Horizontal Adjustment

- Turn the horizontal adjuster [A] on the headlight in or out until the beam points straight ahead.

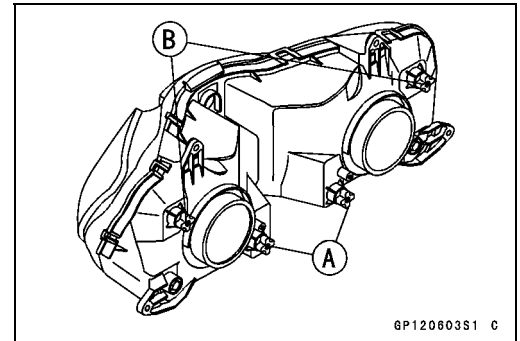

Headlight Beam Vertical Adjustment

- Turn the vertical adjusters [B] on the headlight in or out to adjust the headlight vertically.

NOTE

○ On high beam, the brightest points should be slightly below horizontal with the motorcycle on its wheels and the rider seated. Adjust the headlight(s) to the proper angle according to local regulations.

○ For US model, the proper angle is 0.4 degrees below horizontal. This is 50 mm (2 in) drop at 7.6 m (25 ft) measured from the center of the headlights with the motorcycle on its wheels and the rider seated.

50 mm (2 in) [A]

Center of Brightest Spot [B]

7.6 m (25 ft) [C]

Height of Headlight Center [D]

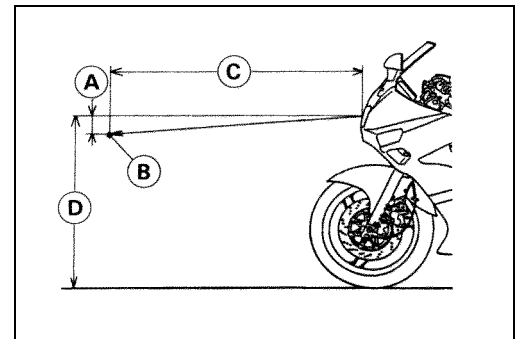

Headlight Bulb Replacement

- Remove:
 - Headlight Connector
 - Headlight Bulb Dust Cover
 - Hook [A]
 - Headlight Bulb [B]

CAUTION

When handling the quartz-halogen bulb, never touch the glass portion with bare hands. Always use a clean cloth. Oil contamination from hands or dirty rags can reduce bulb life or cause the bulb to explode.

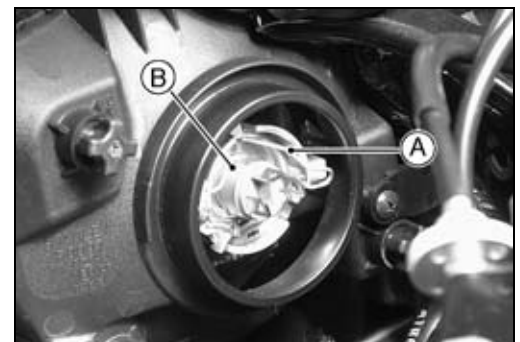

NOTE

○ Clean off any contamination that inadvertently gets on the bulb with alcohol or soap and water solution.

15-52 ELECTRICAL SYSTEM

Lighting System

- Replace the headlight bulb.
- Fit the dust cover [A] with the Top mark [B] upward onto the bulb [C] firmly as shown.
- After installation, adjust the headlight aim (see this chapter).

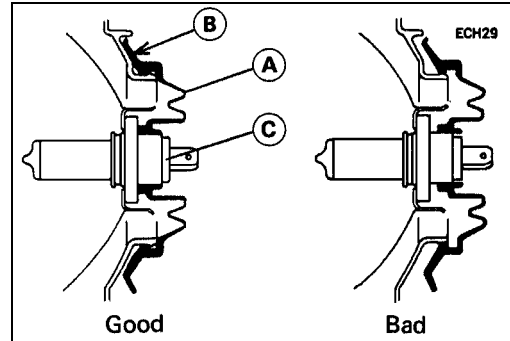

Headlight Relay Unit Inspection

- Remove the windshield.
- Take off the headlight relay units [A].
- Set the hand tester to the $\times 1 \Omega$ range and make the measurements shown in the figure.

Special Tool - Hand Tester: 57001-1394 [B]

- ★ If the tester readings are not as specified, replace the headlight relay unit.

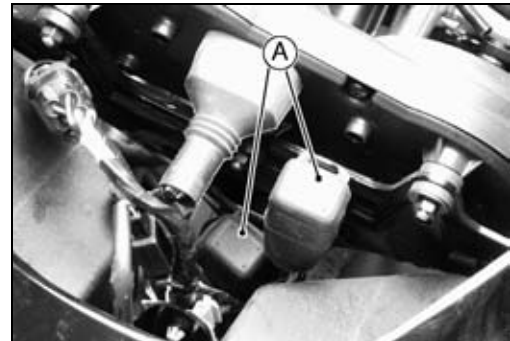

CAUTION

Use only Hand Tester 57001-1394 for this test. An ohmmeter other than the Kawasaki Hand Tester may show different readings. If a megger or a meter with a large-capacity battery is used, the headlight relay unit will be damaged.

Testing Relay

- Criteria:**
- When battery is connected $\rightarrow 0\Omega$
 - When battery is disconnected $\rightarrow \infty\Omega$

Headlight Relay [A]
12 V Battery [C]

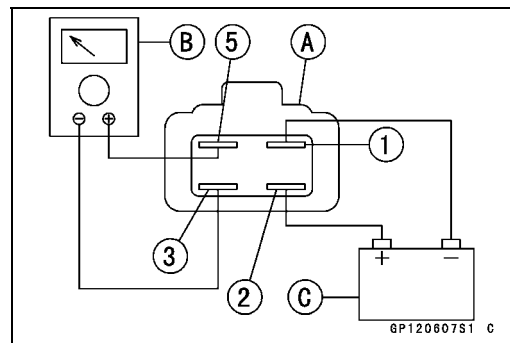

Lighting System

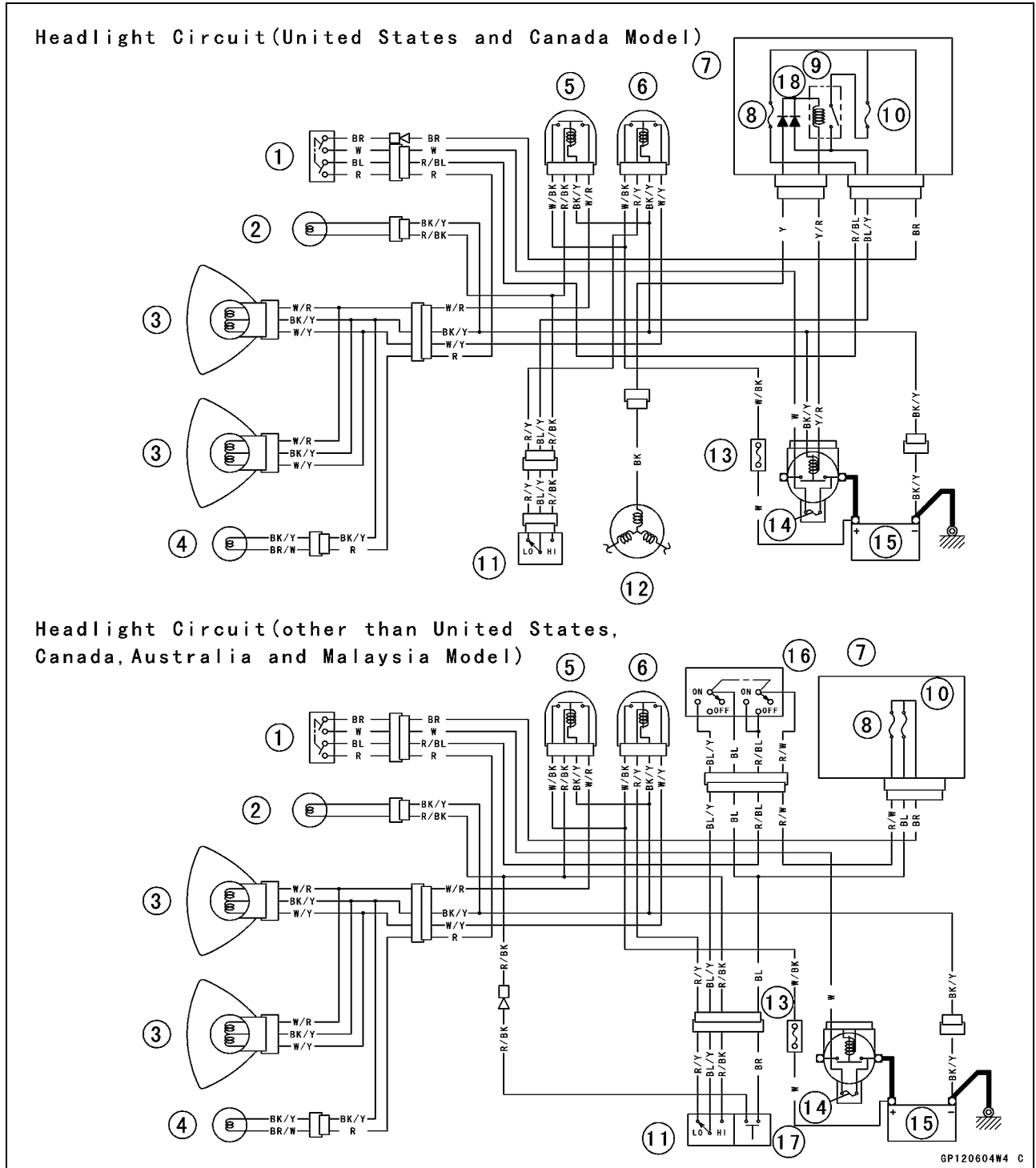

GP120604W4 C

- | | |
|------------------------------|-------------------------|
| 1. Ignition Switch | 10. Headlight Fuse 10 A |
| 2. High Beam Indicator Light | 11. Dimmer Switch |
| 3. Headlight | 12. Alternator |
| 4. City Light | 13. Headlight Fuse 20 A |
| 5. Headlight Relay (Hi) | 14. Main Fuse 30 A |
| 6. Headlight Relay (Lo) | 15. Battery |
| 7. Junction Box | 16. Headlight Switch |
| 8. Tail Light Fuse 10 A | 17. Passing Button |
| 9. Headlight Circuit Relay | 18. Diodes. |

Lighting System

Turn Signal Light Circuit

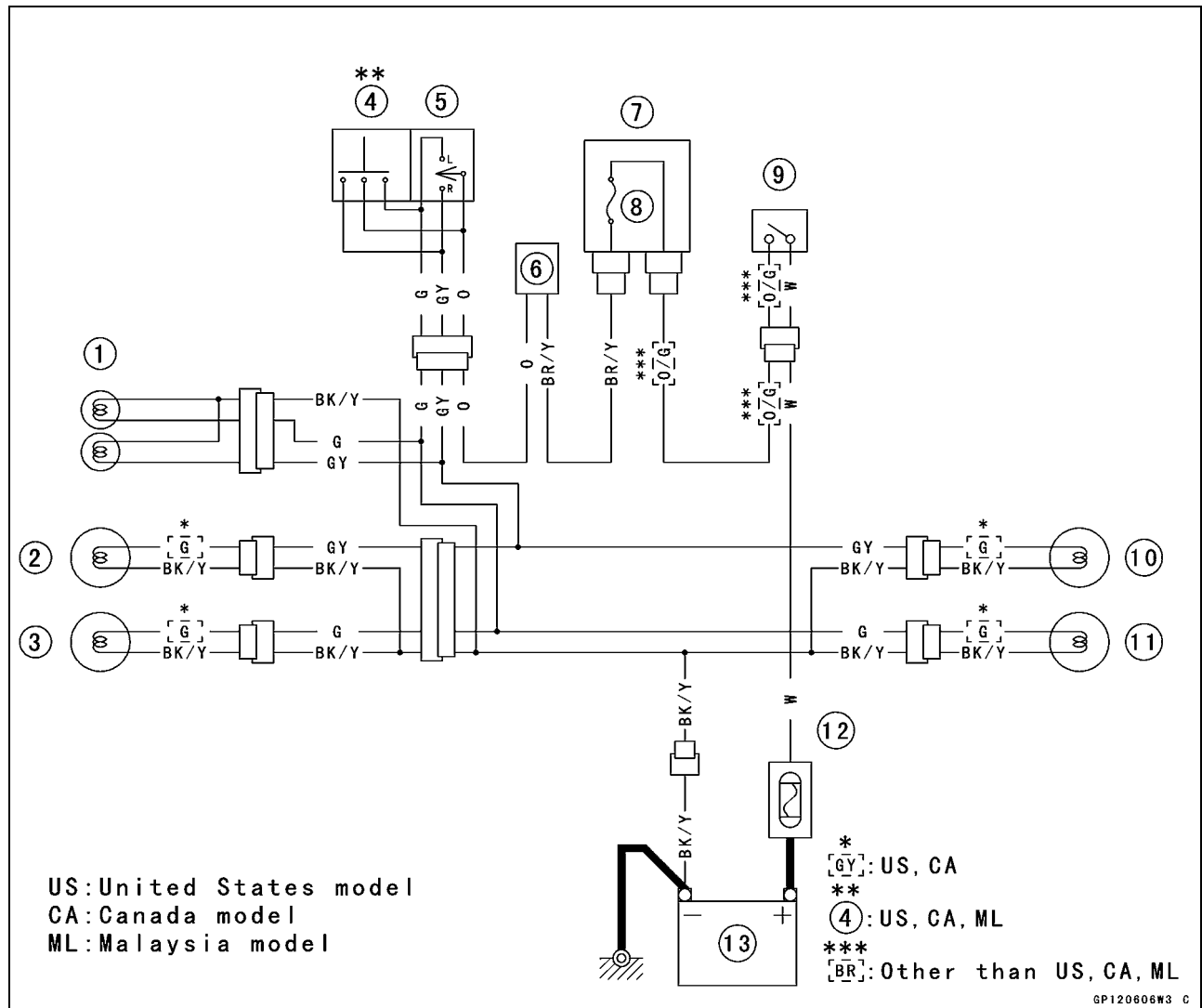

1. Turn Signal Indicator Lights (Right & Left)
2. Front Right Turn Signal Light
3. Front Left Turn Signal Light
4. Hazard Button
5. Turn Signal Switch
6. Turn Signal Relay
7. Junction Box
8. Turn Signal Relay Fuse 10 A
9. Ignition Switch
10. Rear Right Turn Signal Light
11. Rear Left Turn Signal Light
12. Main Fuse 30 A
13. Battery

15-56 ELECTRICAL SYSTEM

Fuel Pump

The fuel pump [A] operates when the starter button is pushed on or the engine is running.

When the fuel level in the float chamber is low, the fuel pump operates to supply the fuel into the float chamber. When the fuel reaches a certain level, the fuel pressure rises, and the fuel pump stops.

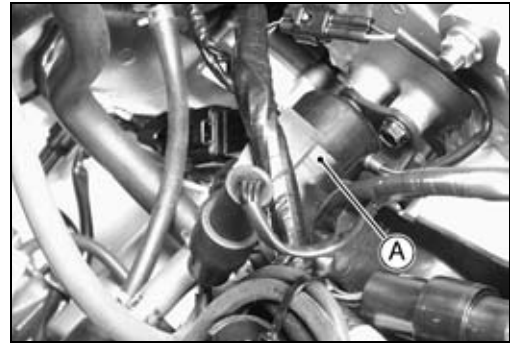

Fuel Pump Removal/Installation

- Refer to the Fuel System chapter.

Fuel Pump Relay Internal Resistance Inspection

- Remove the seats (see Frame chapter).
- Take off the fuel pump relay [A].
- Set the hand tester to the $\times 1 \text{ k}\Omega$ range and make the measurements shown in the table.

Special Tool - Hand Tester: 57001-1394

- ★ If the tester readings are not as specified, replace the fuel pump relay.
- ★ If the tester readings are normal, check the fuel pump operation.



CAUTION

Use only Hand Tester 57001-1394 for this test. An ohmmeter other than the Kawasaki Hand Tester may show different readings. If a megger or a meter with a large-capacity battery is used, the pump relay will be damaged.

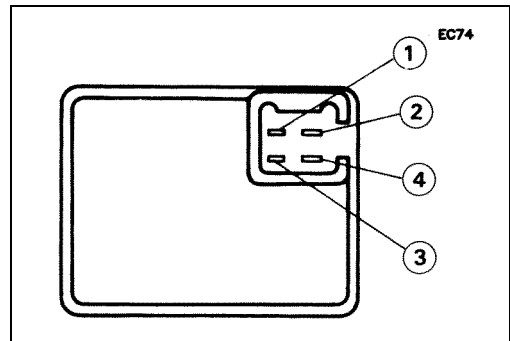

Fuel Pump Relay Internal Resistance

Range \times 1 k Ω	Tester (+) Lead Connection				
	1	2	3	4	
*(-)	1	-	∞	∞	∞
	2	∞	-	∞	∞
	3	∞	10 ~ 100	-	∞
	4	∞	20 ~ 200	1 ~ 5	-

(-)*: Tester (-) Lead Connection

Fuel Pump

Fuel Pump Operational Inspection

- Remove the fuel pump with the fuel filter (see Fuel System chapter).
- Prepare a container filled with kerosene.
- Prepare the rubber hoses, and connect them to the pump fittings.
- Connect a suitable pressure gauge to the outlet hose as shown.

Fuel Pump [A]

Pressure Gauge [B]

Outlet Hose [C]

Inlet Hose [D]

Fuel Filter [E]

Kerosene [F]

2-Pin Connector [G]

Battery [H]

Auxiliary Leads [I]

- Connect the pump leads to the battery using auxiliary wires as shown.
- ★ If the pump operates, check the pump relay.
- ★ If the pump does not operate, the pump is defective.
- ★ If the pump operates and the pump relay is normal, close the outlet hose while operating the fuel pump.
- When the pump stops, read the pressure gauge.
- ★ If the pressure gauge reading is out of the specified pressure, the pump is defective.

Fuel Pump Pressure

Standard: 11 ~ 16 kPa (0.11 ~ 0.16 kgf/cm², 1.6 ~ 2.3 psi)

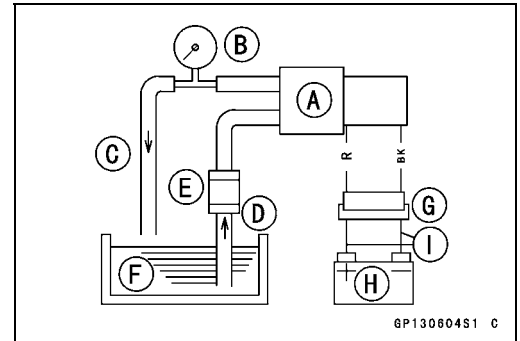

Fuel Cut Valve

The fuel cut valves [A] are adopted for protection of the catalytic converter.

Fuel Cut Valve Removal

⚠ WARNING

Gasoline is extremely flammable and can be explosive under certain conditions. Turn the ignition switch OFF. Do not smoke. Make sure the area is well-ventilated and free from any source of flame or sparks; this includes any appliance with a pilot light.

- Remove the fuel tank (see Fuel System chapter).
- Connect a suitable hose to the fitting at the bottom of each carburetor float bowl.
- Run the lower ends of the hoses into a suitable container.
- Turn out each drain plug a few turns and drain the float bowls.

**Special Tool - Carburetor Drain Plug Wrench, Hex 3:
57001-1269**

- Disconnect the connectors [B] of the fuel cut valves.
- Loosen the fuel cut valves and remove them.

Fuel Cut Valve Installation

- Install the fuel cut valves with a gray connector [A] on the #1, #4 carburetors.
- Install the fuel cut valves with a brown connector [A] on the #2, #3 carburetors.
- Do not install the fuel cut valves on the wrong carburetors. The fuel cut valves will not work well.

Fuel Cut Valve Inspection

- Remove the fuel cut valve [A].
- Connect and disconnect one 12 V battery [B] to the fuel cut valve connector as shown. The valve rod moves.
- ★ If the protrusion exceeds the standard (too long or too short), the valve is defective and must be replaced.

Testing Fuel Cut Valve Standard Protrusion

When battery is disconnected → 16.6 mm (0.65 in.)

When battery is connected → 18.6 ~ 19.1 mm
(0.73 ~ 0.75 in.)

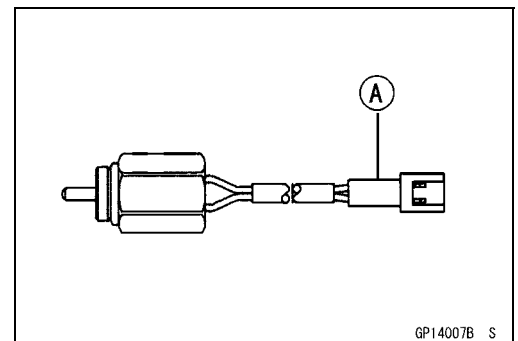
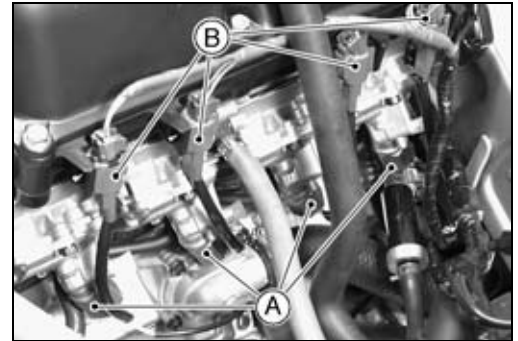

GP14007B S

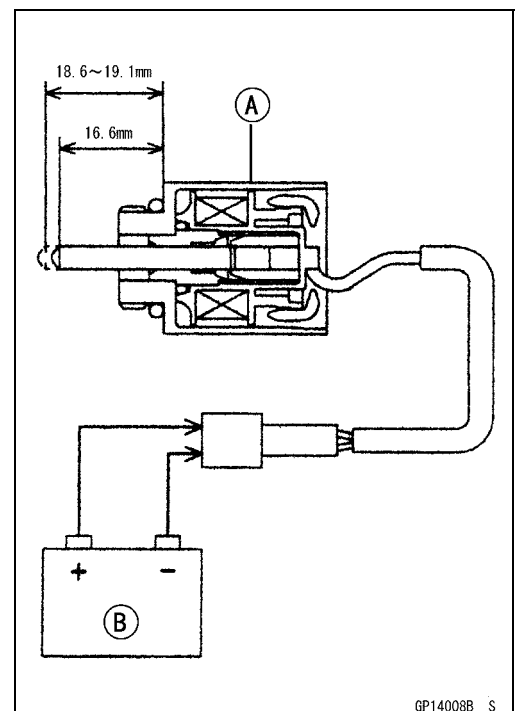

GP14008B S

15-60 ELECTRICAL SYSTEM

Fuel Cut Valve

Fuel Cut Valve Circuit

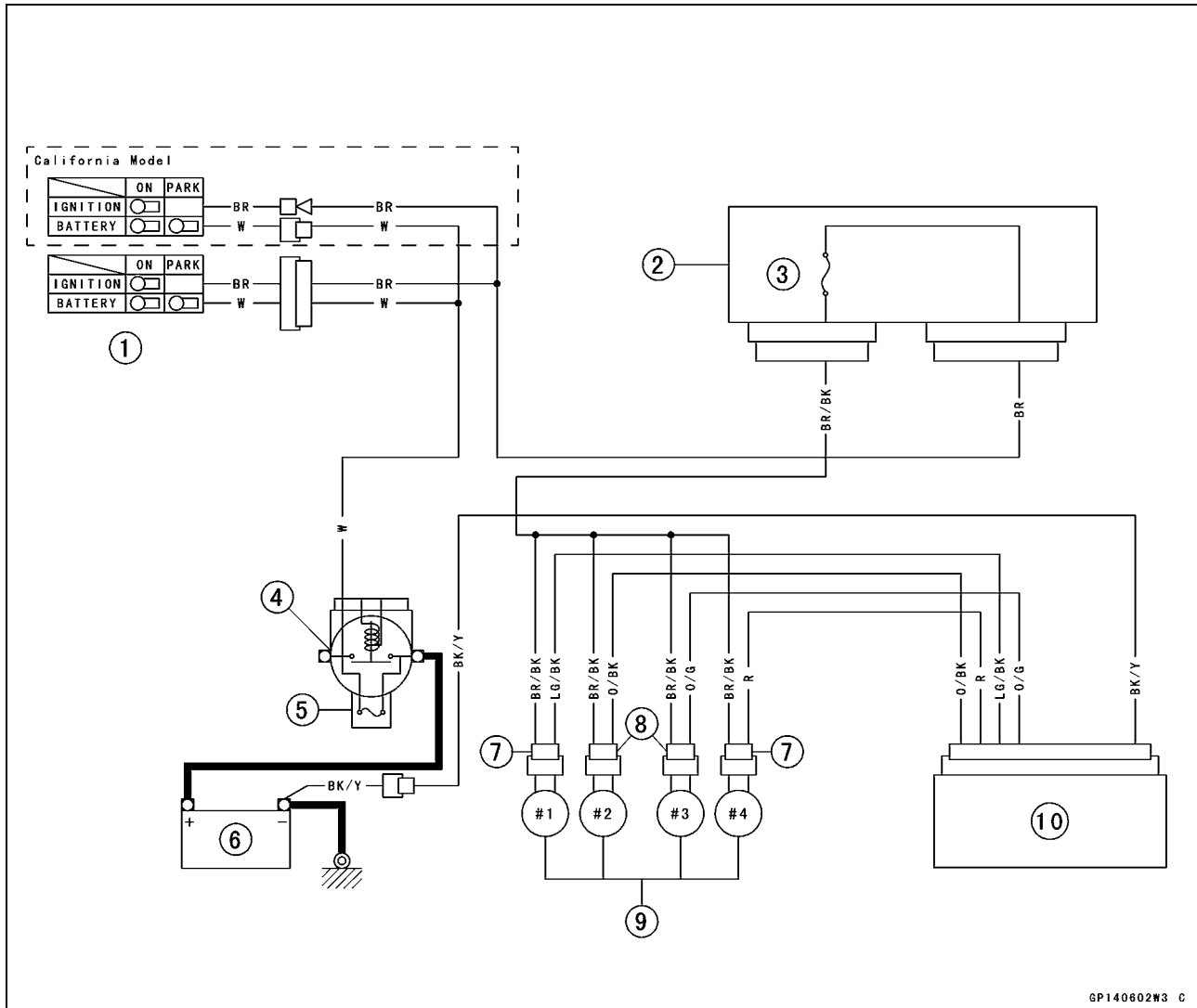

1. Ignition Switch
2. Junction Box
3. Horn Fuse 10 A
4. Starter Relay
5. Main Fuse 30 A
6. Battery
7. Gray Connector
8. Brown Connector
9. Fuel Cut Valve
10. IC Igniter

Radiator Fan System

⚠ WARNING

The radiator fan is connected directly to the battery. The fan may start even if the ignition switch is off. **NEVER TOUCH THE RADIATOR FAN UNTIL THE RADIATOR FAN CONNECTOR IS DISCONNECTED. TOUCHING THE FAN BEFORE THE CONNECTOR IS DISCONNECTED COULD CAUSE INJURY FROM THE FAN BLADES.**

Fan System Circuit Inspection

- Disconnect the leads from the radiator fan switch [A].
- Using an auxiliary wire [B], connect the radiator fan switch leads.
- ★ If the fan rotates, inspect the fan switch.
- ★ If the fan does not rotate, inspect the following.
 - Leads and Connectors
 - Main Fuse and Fan Fuse
 - Fan Motor

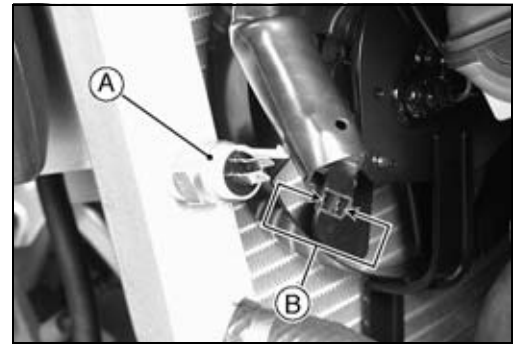

Fan Motor Inspection

- Remove the left lower fairing (see Frame chapter).
- Disconnect the 2-pin connector [A] in the fan motor leads.
- Using two auxiliary wires, supply battery [B] power to the fan motor.
- ★ If the fan does not rotate, the fan motor is defective and must be replaced.

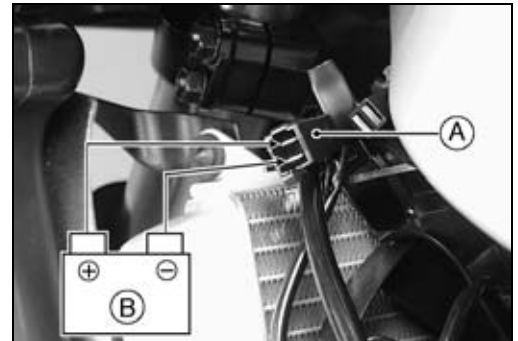

15-62 ELECTRICAL SYSTEM

Radiator Fan System

Radiator Fan Circuit

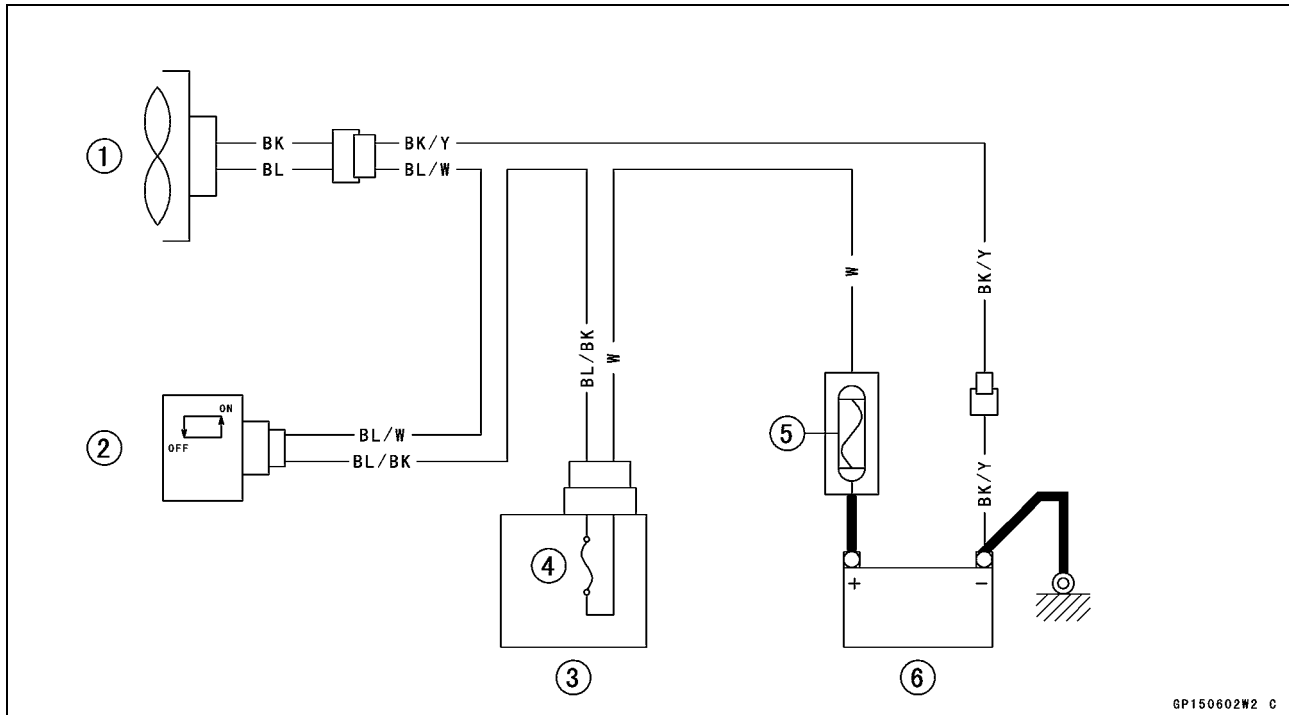

GP150602W2 C

1. Radiator Fan
2. Radiator Fan Switch
3. Junction Box
4. Fan Fuse 10 A
5. Main Fuse 30 A
6. Battery

Meter, Gauge, Indicator Unit

Meter Unit Removal

- Remove:
 - Windshield (see Handlebar Removal in the Steering chapter)
- Remove the meter unit by taking off the mounting nuts [A] with the washers.
- Slide the dust cover [B] and remove the wiring connector.

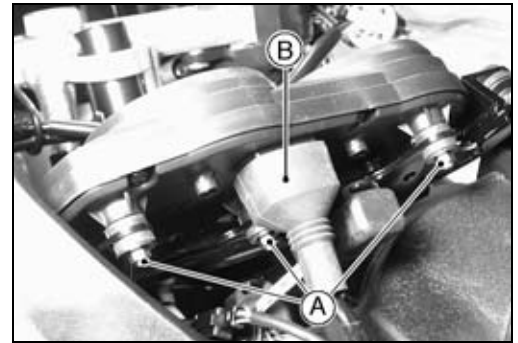

CAUTION

Place the meter unit so that the face is up. If a meter unit is left upside down or sideways for any length of time, it will malfunction.

Meter, Gauge Disassembly

- Remove:
 - Meter Unit (see Meters, Gauge Removal)
 - Screws [A]
 - Lower Meter Cover [B]

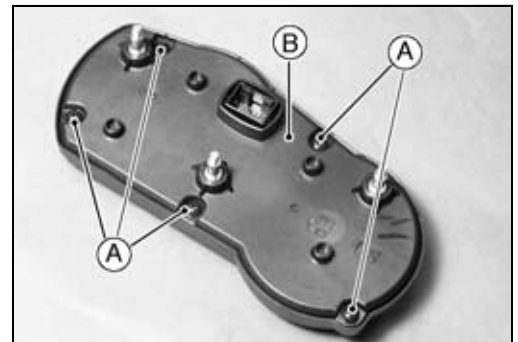

- Separate the meter assembly [A] and upper meter cover [B].

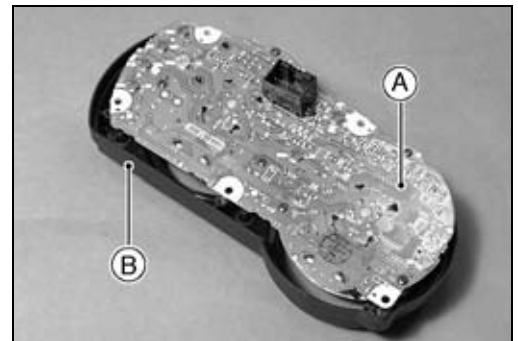

Bulb Replacement

- Remove:
 - Meter Unit
- Turn out the socket [A] counterclockwise.
- Pull the bulb out of the socket.

CAUTION

Do not turn the bulb. Pull the bulb out to prevent damage to the bulb. Do not use bulb rated for greater wattage than the specified value.

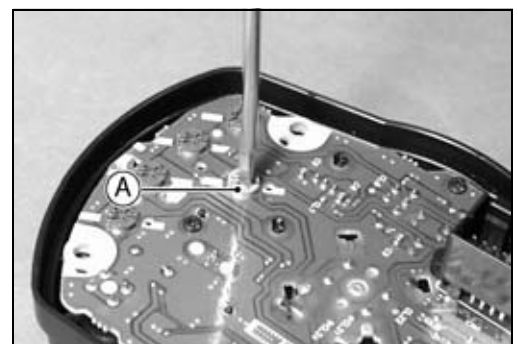

15-64 ELECTRICAL SYSTEM

Meter, Gauge, Indicator Unit

Electronic Combination Meter Unit Inspection

- Remove the meter unit.

CAUTION

Do not drop the meter unit. Place the meter unit so that it faces upward. If the meter unit is left upside down or sideways for a long time or dropped, it will malfunction.

- Using the auxiliary wires, connect the 12 V battery [A] to the meter unit connector [B] as follows.

- Connect the battery positive terminal to the terminal [1].
- Connect the battery negative terminal to the terminal [2].

- [1] Battery (Positive)
- [2] Battery (Negative)
- [3] Ignition
- [4] Speed Sensor Electric Source
- [5] Speed Sensor Pulse
- [6] Tachometer Pulse
- [7] Water Temperature

CAUTION

Do not short the terminals [2], [4] and [4], [5].

Liquid Crystal Display (LCD) Segments Check

- Connect the battery positive terminal to the terminal [1].
- Connect the battery negative terminal to the terminal [2].
- Connect the terminal [1] to the terminal [3].

- When the terminals are connected, all the LCD segments [A] and LED warning light [B] appear for three seconds.

- When the terminals are disconnected within three seconds, all the LCD segments and LED warning light disappear.

- ★ If the LCD segments and LED warning light will not appear, replace the meter unit.

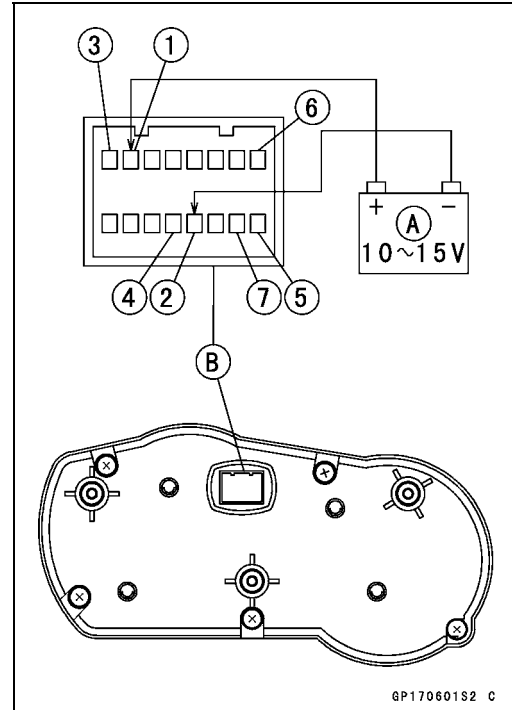

GP170601S2 C

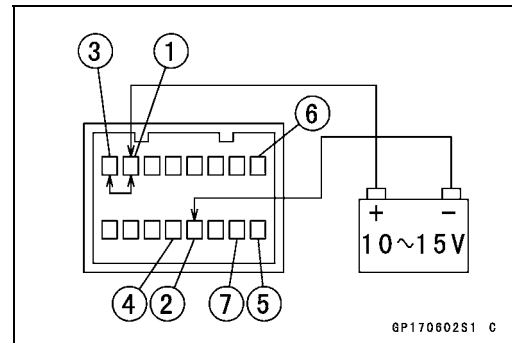

GP170602S1 C

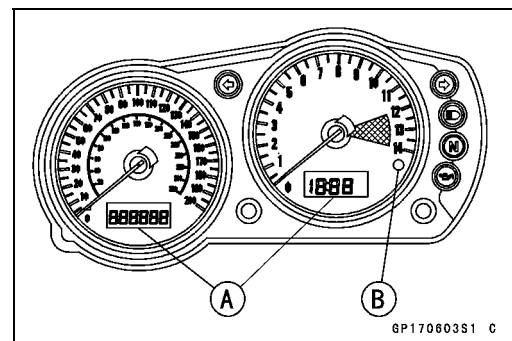

GP170603S1 C

Meter, Gauge, Indicator Unit

ODO/TRIP or CLOCK/TEMP BUTTON Operate Confirmation

- Connect the 12 V battery and terminals in the same manner as specified in the "Liquid Crystal Display (LCD) Segments Check".
- Check that when the button [A] or [B] is pushed and held continuously, the display [C] or [D] turns an other mode within two seconds.
 - [A] ODO/TRIP
 - [B] CLOCK/TEMP
 - [C] ODO METER → TRIP METER → ODO METER
 - [D] CLOCK → TEMPERATURE → CLOCK

★ If the display function does not work, replace the meter unit.

- Indicate the clock mode.
- Check that when the button in CLOCK mode is pushed for more than two seconds, the meter display turns to the clock set mode.
- Check that it is possible to adjust hours and minutes.
- ★ If the display function does not work and adjust, replace the meter unit.

- Indicate the temp mode.
- Check that when the button in TEMP mode is pushed for more than two seconds, the figure display turns to Celsius degree or Fahrenheit degree of water temperature.

Speedometer Check

- Connect the 12 V battery and terminals in the same manner as specified in the "Liquid Crystal Display (LCD) Segments Check".
- The speed equivalent to the input frequency is indicated in the oscillator [A] if the square wave (illustrated as shown) would be input into the terminal [5].
 - Indicates approximately 60 mph in case the input frequency would be approximately 146 Hz.
 - Indicates approximately 60 km/h in case the input frequency would be approximately 91 Hz.

- If the oscillator is not available, the speedometer can be checked as follows.
 - Install the meter unit.
 - Raise the rear wheel off the ground, using the jack.
 - Turn on the ignition switch.
 - Rotate the rear wheel by hand.
 - Check that the speedometer shows the speed.
- ★ If the speedometer does not work, check the speed sensor electric source voltage and speed sensor.

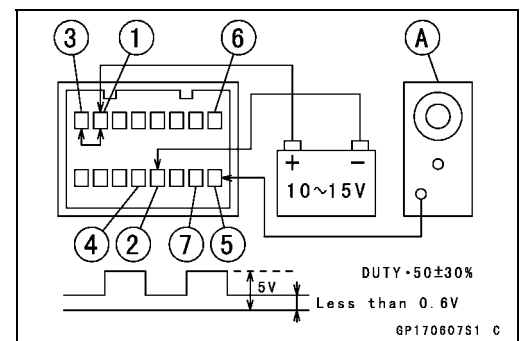
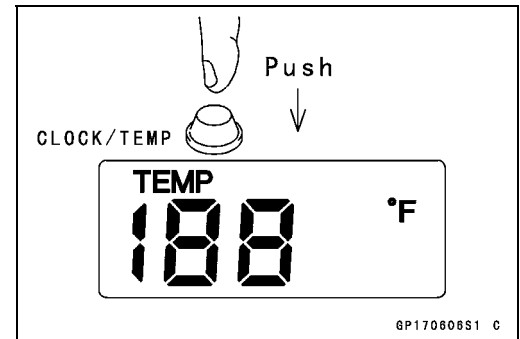
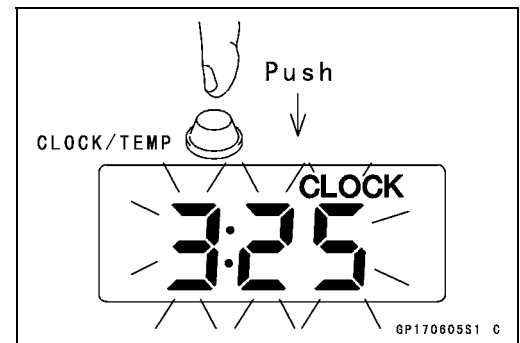
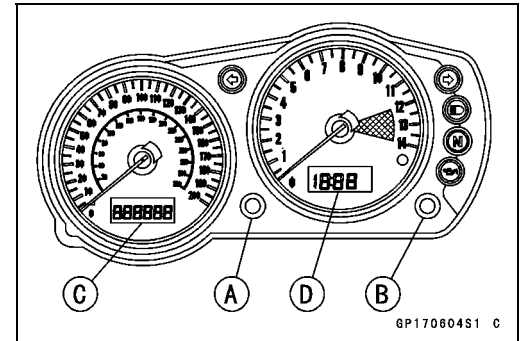

15-66 ELECTRICAL SYSTEM

Meter, Gauge, Indicator Unit

Speed Sensor Electric Source Check

- Connect the 12 V battery and terminals in the same manner as specified in the "Liquid Crystal Display (LCD) Segments Check".
- Set the hand tester to the DC25 V range and connect it to the terminals [2] and [4].
- ★ If the voltage is less than 7 V, replace the meter unit.

CAUTION

Do not short the terminals [2], [4] and [4], [5].

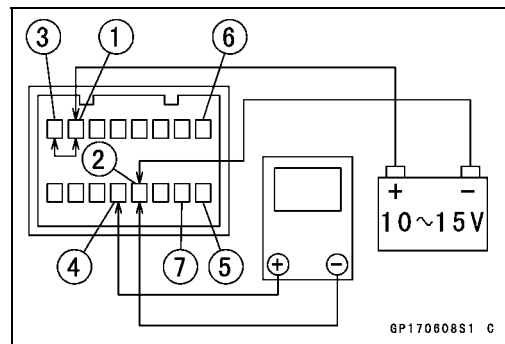

Odometer Check

- Check the odometer with the speedometer in the same way.
- ★ If value indicated in the odometer is not added, replace the meter unit.

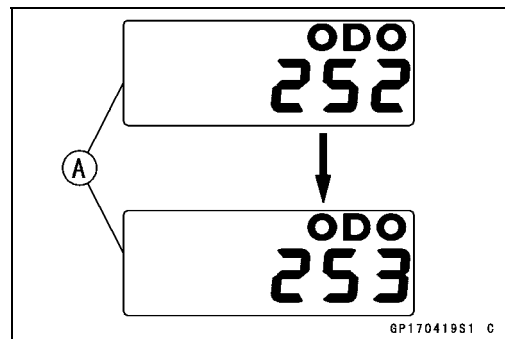

Trip Meter Check

- Check the trip meter with the speedometer in the same way.
- ★ If value indicated in the trip meter is not added, replace the meter unit.
- Check that when the ODO/TRIP button is pushed for more than two seconds, the figure display turns to 0.0.
- ★ If the figure display does not indicate 0.0, replace the meter unit.

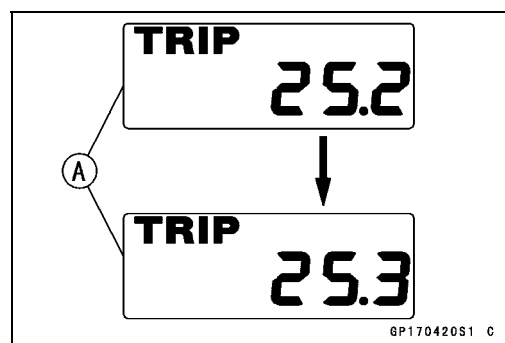

Water Temperature Meter Check

- Connect the 12 V battery and terminals in the same manner as specified in the "Liquid Crystal Display (LCD) Segments Check".
- Connect the variable rheostat [A] to the terminal [7] as shown.
- Check that the number of segments matches the resistance value of the variable rheostat.

Resistance Value (Ω)	Temperature METER [A]	Warning Light [B]
9560	50°C (122°F)	OFF
2780	80°C (176°F)	OFF
950	110°C (230°F)	OFF
810	115°C (239°F)	ON
690	HI	Flash

- If any display function does not work, replace the meter unit.

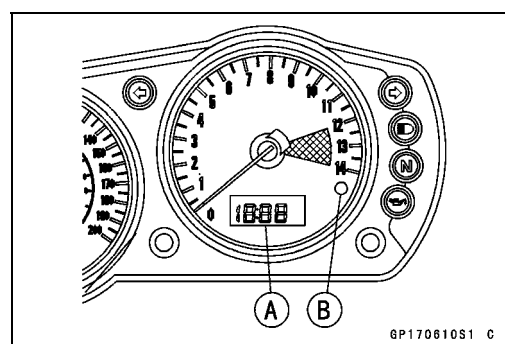
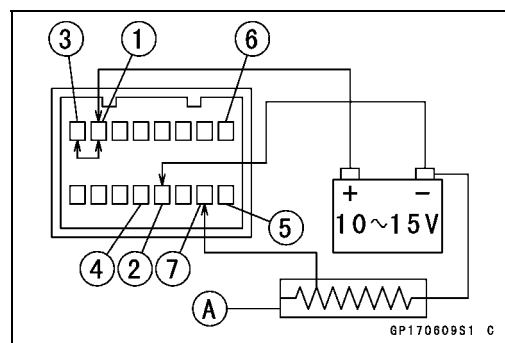

Meter, Gauge, Indicator Unit

Tachometer Check

- Connect the 12 V battery and terminals in the same manner as specified in the "Liquid Crystal Display (LCD) Segments Check".
- The revolutions per minute (rpm) equivalent to the input frequency is indicated in the oscillator [A] if the square wave (illustrated as shown) would be input into the terminal [6].
- Indicates approximately 6000 rpm in case the input frequency would be approximately 200 Hz.
- If the oscillator is not available, the tachometer can be checked as follows.
 - Connect the 12 V battery and terminals in the same manner as specified in the "Liquid Crystal Display (LCD) Segments Check".
 - Using an auxiliary wire, open and connect the terminal [1] to the terminal [6] repeatedly.
 - Then the tachometer hand [A] should flick [B].
 - ★ If the hand does not flick, replace the meter unit.

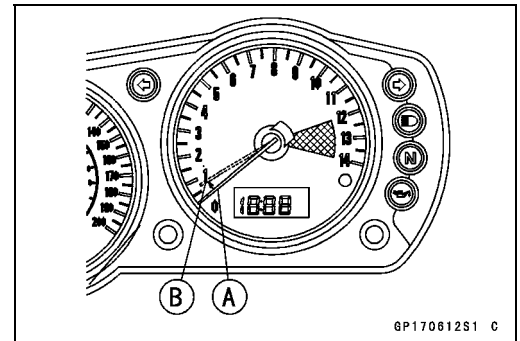
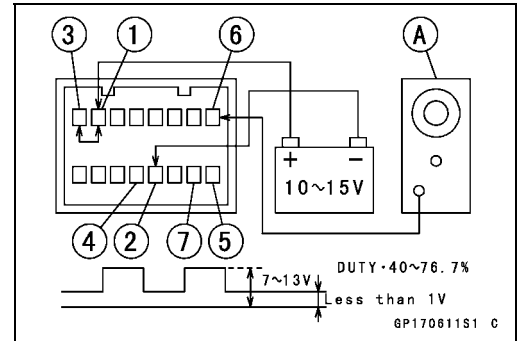

Meter Circuit

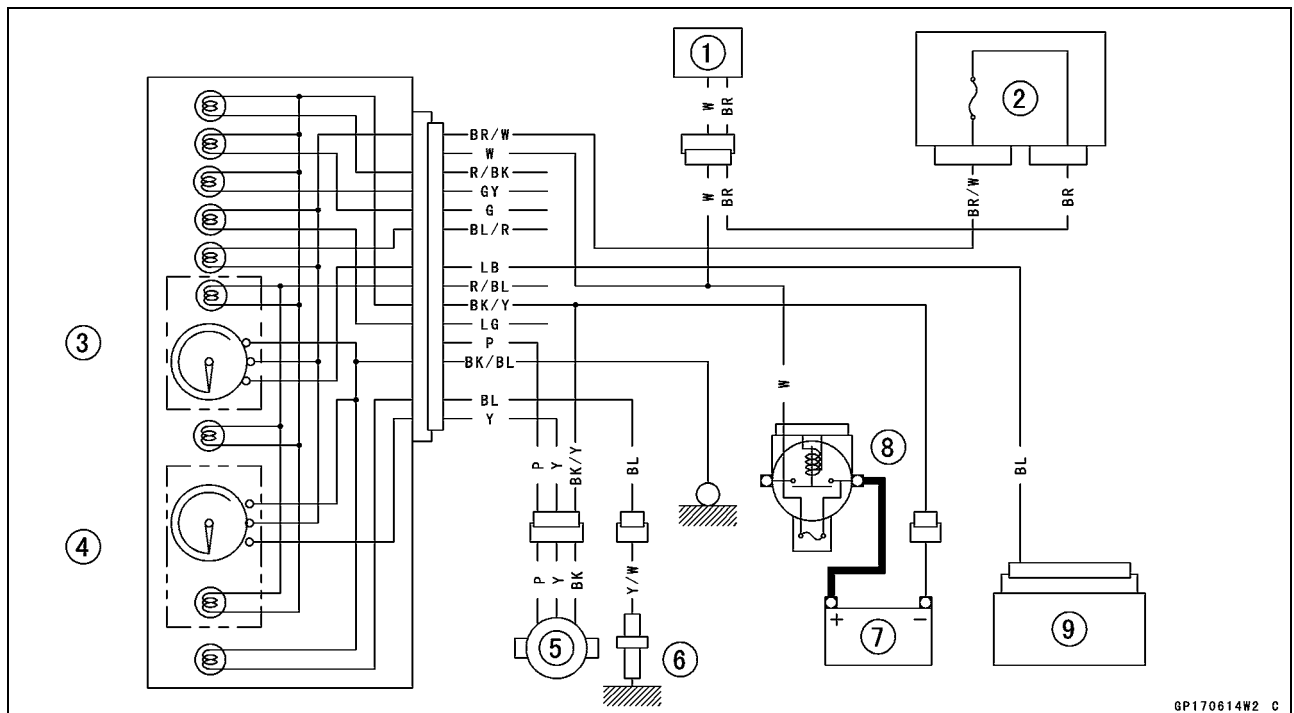

1. Ignition Switch
2. Junction Box
3. Tachometer
4. Speedometer
5. Speed Sensor
6. Water Temperature Sensor
7. Battery
8. Main Fuse (30 A)
9. IC Igniter

15-68 ELECTRICAL SYSTEM

Switches and Sensors

Brake Light Timing Inspection

- Turn on the ignition switch.
- Check the operation of the rear brake light switch by depressing the brake pedal.
- ★ If it does not as specified, adjust the brake light timing.

Brake Light Timing

Standard: On after about 10 mm (3.94 in.) of pedal travel [A]



Brake Light Timing Adjustment

Brake light timing is adjusted by changing the position of the rear brake light switch.

- Adjust the position of the switch so that the brake light goes on after the specified pedal travel by turning the adjusting nut [A].

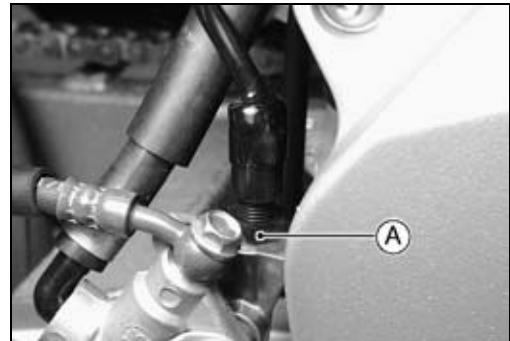

CAUTION

To avoid damaging the electrical connections inside the switch, be sure that the switch body does not turn during adjustment.

Switch Inspection

- Using a hand tester, check to see that only the connections shown in the table have continuity (about zero ohms).
- For the handlebar switches and the ignition switch, refer to the tables in the Wiring Diagram.
- ★ If the switch has an open or short, repair it or replace it with a new one.

Special Tool - Hand Tester: 57001-1394

Rear Brake Light Switch Connections

	BR	BL
When brake pedal is pushed down	○ — ○	
When brake pedal is released		

Side Stand Switch Connections

	G	BK
When side stand is up	○ — ○	
When side stand is down		

Neutral Switch Connections

	SW. Terminal	TTT
When transmission is in neutral	○ — ○	
When transmission is not in neutral		

Oil Pressure Switch Connections*

	SW. Terminal	TTT
When engine is stopped	○ — ○	
When engine is running		

*: Engine lubrication system is in good condition

Switches and Sensors

Radiator Fan Switch Inspection

- Remove the fan switch (see Cooling System chapter).
- Suspend the switch [A] in a container of coolant so that the temperature-sensing projection and threaded portion are submerged.
- Suspend an accurate thermometer [B] in the coolant so that the sensitive portions [C] are located in almost the same depth.

NOTE

○ The switch and thermometer must not touch the container sides or bottom.

- Place the container over a source of heat and gradually raise the temperature of the coolant while stirring the coolant gently.
- Using the hand tester, measure the internal resistance of the switch across the terminals at the temperatures shown in the table.

Special Tool - Hand Tester: 57001-1394

- ★ If the hand tester does not show the specified values, replace the switch.

Fan Switch Resistance

○ Rising temperature:

From OFF to ON at 96 ~ 100°C (205 ~ 212°F)

○ Falling temperature:

From ON to OFF at 91°C (196°F) or less

ON: Less than 0.5 Ω

OFF: More than 1 MΩ

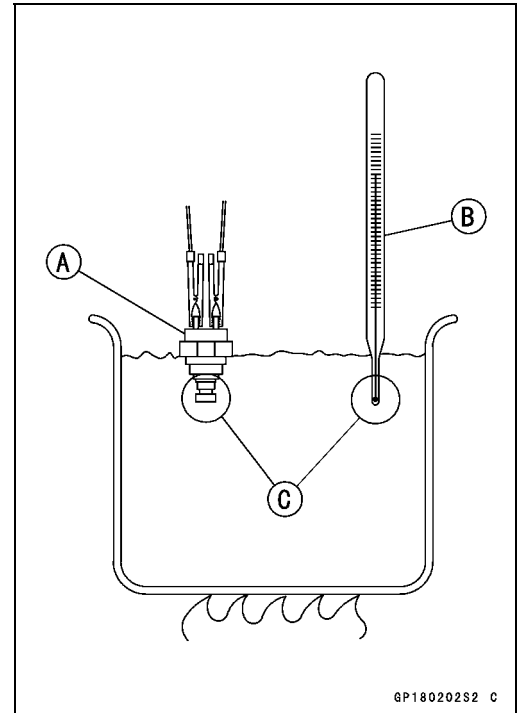

15-70 ELECTRICAL SYSTEM

Switches and Sensors

Water Temperature Sensor Inspection

- Remove the water temperature sensor (see Cooling System chapter).
- Suspend the sensor [A] in a container of coolant so that the temperature-sensing projection and threaded portion are submerged.
- Suspend an accurate thermometer [B] in the coolant so that the sensitive portions [C] are located in almost the same depth.

NOTE

○ The sensor and thermometer must not touch the container side or bottom.

- Place the container over a source of heat and gradually raise the temperature of the coolant while stirring the coolant gently.
- Using the hand tester, measure the internal resistance of the sensor across the terminal and the body at the temperatures shown in the table.

Special Tool - Hand Tester: 57001-1394

- ★ If the hand tester does not show the specified values, replace the sensor.

Water Temperature Sensor Resistance

50°C (122°F): 9.18 ~ 9.94 kΩ

80°C (176°F): 2.50 ~ 3.06 kΩ

120°C (248°F): 0.65 ~ 0.73 kΩ

Throttle Sensor Removal/Installation

- Remove the carburetors (see Fuel System chapter).
- Remove the throttle sensor [A] by unscrewing the mounting screws.
- Be sure to adjust the throttle sensor when installing (see Throttle Sensor Adjustment).

Throttle Sensor Inspection

- Remove the fuel tank (see Fuel System chapter).
- Prepare an auxiliary fuel tank and connect the fuel hose to the carburetors.
- Start the engine and warm it up thoroughly.
- Check:
 - Idle Speed (see Fuel System chapter)
 - Battery Charging Condition (see this chapter)
- Turn off the ignition switch.
- Remove the throttle sensor lead connector [A].

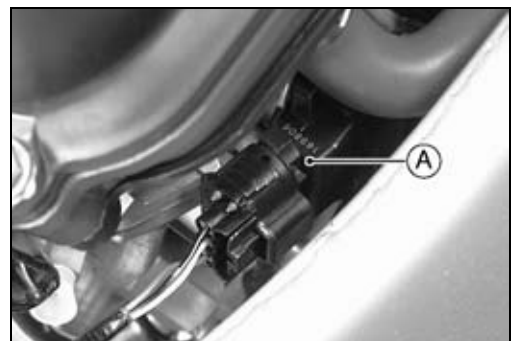
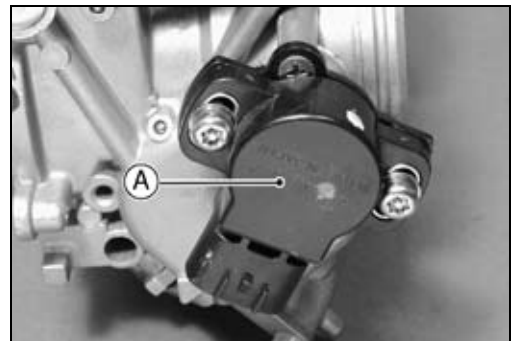
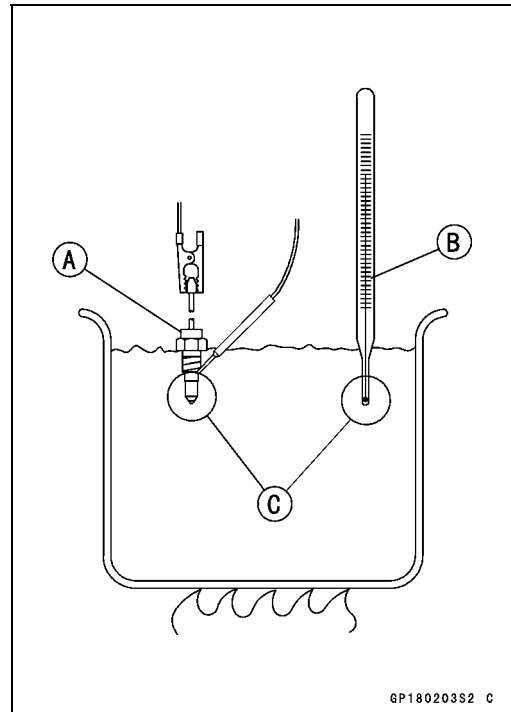

Switches and Sensors

- Connect the adapter [B] between the connectors [A].
Special Tool - Throttle Sensor Setting Adapter: 57001-1521
- Connect the hand tester to the adapter.
 Hand Tester (+) → Y/W Lead [C]
 Hand Tester (-) → BK/BL Lead [D]
- Start the engine.
- Check the sensor output voltage with the engine idling.

Throttle Sensor Output Voltage

Standard: 0.95 ~ 1.05 V (When engine is idling.)

- ★ If it is not within the specified voltage, adjust the throttle sensor position (see Throttle Sensor Position Adjustment).
- ★ If it is specified voltage, go to next test.
- Stop the engine.
- Turn on the ignition switch.
- Check the sensor output voltage with the throttle fully open.

Throttle Sensor Output Voltage

Standard: 3.95 ~ 4.15 V (When throttle is fully opened.)

- ★ If it is not within the specified voltage, replace the sensor.

Throttle Sensor Position Adjustment

- Start the engine.
- Check idle speed (see Fuel System chapter).
- Stop the engine and remove the carburetor.

CAUTION

Do not turn the idle adjusting screw when removing the carburetor.

- Connect the throttle sensor setting adapter to the sensor lead connectors (see Throttle Sensor Inspection).

Special Tool - Throttle Sensor Setting Adapter: 57001-1521

- Loosen the throttle sensor mounting screws [A].
- Turn on the ignition switch.
- When installing the sensor, tighten the screws gradually and alternately.

Torque - Throttle Sensor mounting Screw: 3.4 N·m (0.35 kgf·m, 30 in·lb)

- Adjust the position of the throttle sensor until the output voltage is within the specified voltage.

Throttle Sensor Output Voltage

Standard: 0.95 ~ 1.05 V

- ★ If it is not within the specified voltage, replace the sensor.
- When installing the sensor, tighten the screws gradually and alternately.

Torque - Throttle Sensor Mounting Screw: 3.4 N·m (0.35 kgf·m, 30 in·lb)

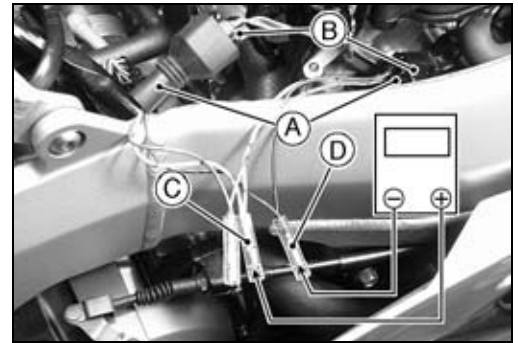

15-72 ELECTRICAL SYSTEM

Switches and Sensors

Speed Sensor Inspection

- Remove:
Speed Sensor (see Final Drive chapter)
- Connect the speed sensor connector [A] with the battery [B], 10 kΩ resistor [C] and hand tester [D] as shown.
- Set the tester to the DC 25 V range.

Special Tool - Hand Tester: 57001-1394

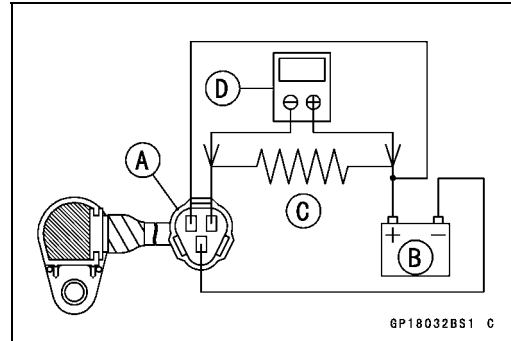

- Trace [A] each side of the speed sensor surface with the screw driver.
- Then the tester indicator should flick [B].
- ★ If the tester indicator does not flick, replace the speed sensor.

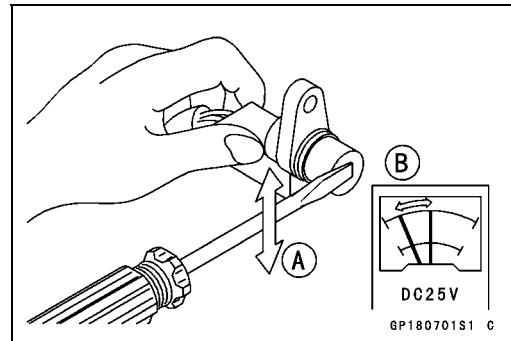

Junction Box

The junction box [A] has fuses [B], relays, and diodes. The relays and diodes can not be removed.

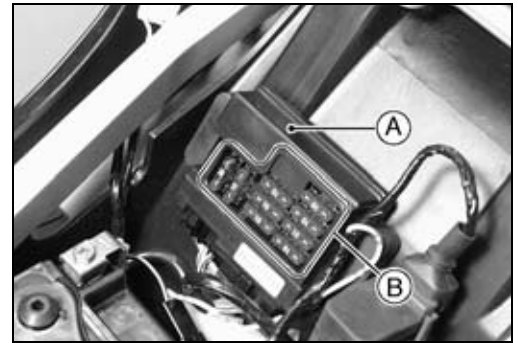

Junction Box Fuse Circuit Inspection

- Remove the seats (see Frame chapter).
- Remove the junction box.
- Pull off the connectors from the junction box.
- Make sure all connector terminals are clean and tight, and none of them have been bent.
- ★ Clean the dirty terminals, and straighten slightly-bent terminals.
- Check conductivity of the numbered terminals with the hand tester.
- ★ If the tester does not read as specified, replace the junction box.

Special Tool - Hand Tester: 57001-1394

Fuse Circuit Inspection

Tester Connection	Tester Reading (Ω)	Tester Connection	Tester Reading (Ω)
1-1A	0	1A-8	∞
1-2	0	2-8	∞
3A-4	0	3A-8	∞
6-5	0	6-2	∞
6-10	0	6-3A	∞
6-7	0	17-3A	∞
6-17	0		

Starter Circuit/Headlight Relay Inspection

- Remove the junction box.
- Check conductivity of the following numbered terminals by connecting the hand tester and one 12 V battery to the junction box as shown.
- ★ If the tester does not read as specified, replace the junction box.

Special Tool - Hand Tester: 57001-1394

Relay Circuit Inspection (with the battery disconnected)

Tester Connection	Tester Reading (Ω)	Tester Connection	Tester Reading (Ω)
*7 - 8	∞	9 - 11	∞

15-74 ELECTRICAL SYSTEM

Junction Box

Headlight Relay	*7 - 13	∞	Starter Circuit Relay	12 - 13	∞
	(+) (-) *13 - 9	Not ∞ **		(+) (-) 13 - 11	∞
				(+) (-) 12 - 11	Not ∞ **

(*): United States, Canada, Australia , and Malaysia Models only

(**): The actual reading varies with the hand tester used.

(+): Apply tester positive lead.

(-): Apply tester negative lead.

Relay Circuit Inspection (with the battery connected)

	Battery Connection (+) (-)	Tester Connection	Tester Reading (Ω)
Headlight Relay	*9-13	*7-8	0
Starter Circuit Relay	11-12	(+) (-) 13-11	Not ∞ **

(*): United States, Canada, Australia , and Malaysia Models only

(**): The actual reading varies with the hand tester used.

(+): Apply tester positive lead.

(-): Apply tester negative lead.

Diode Circuit Inspection

- Remove the junction box.
- Check conductivity of the following pairs of terminals.

Diode Circuit Inspection

Tester Connection	*13-8, *13-9, 12-11, 12-14, 15-14, 16-14
-------------------	--

*: United States, Canada, Australia, and Malaysia Models only

- ★ The resistance should be low in one direction and more than ten times as much in the other direction. If any diode shows low or high in both directions, the diode is defective and the junction box must be replaced.

NOTE

○ The actual meter reading varies with the meter used and the individual diodes, but, generally speaking, the lower reading should be from zero to one half the scale.

Junction Box

Junction Box Internal Circuit (United States, Canada, Australia, and Malaysia)

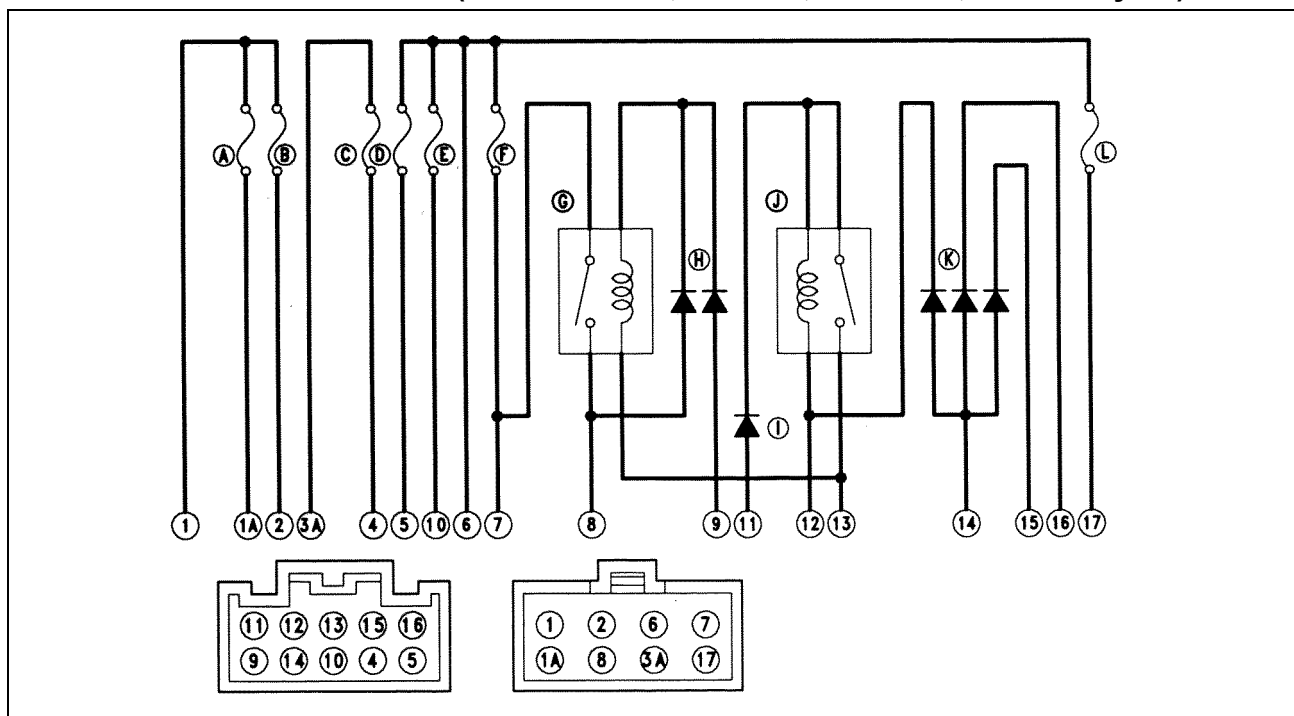

Junction Box Internal Circuit (Other than United States, Canada, Australia, and Malaysia)

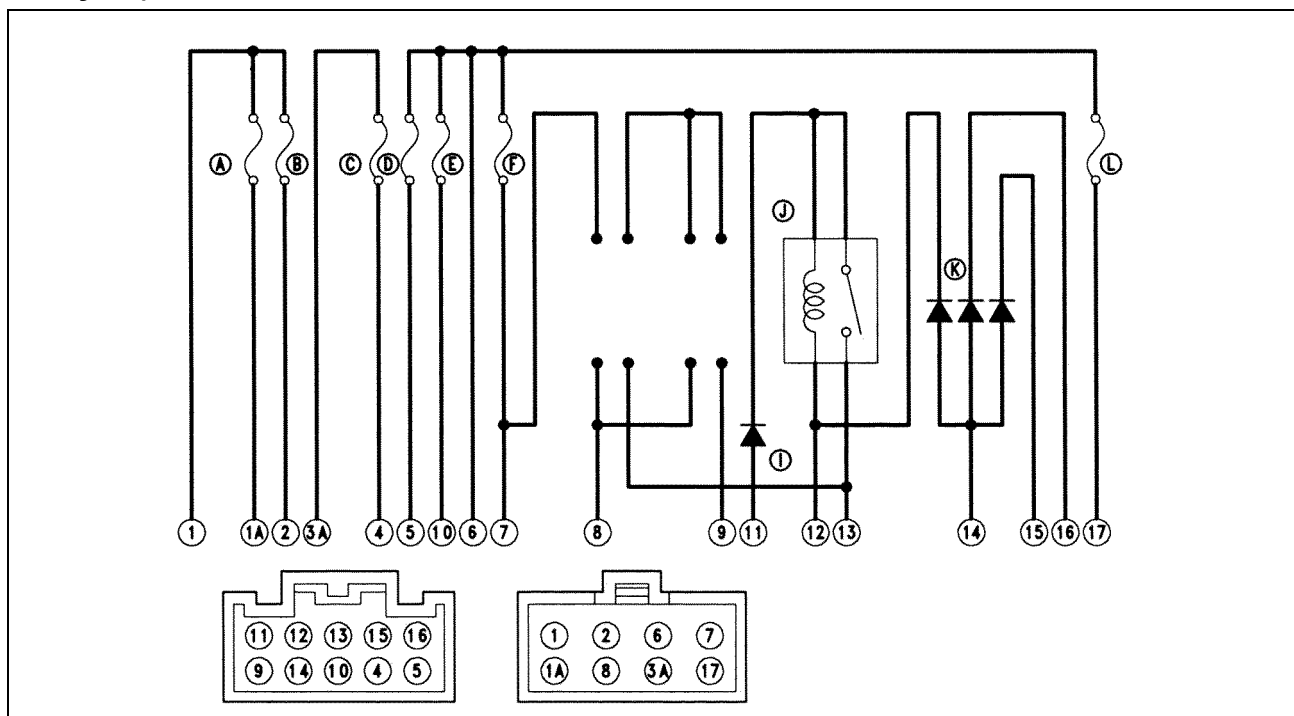

- A. Accessory Fuse 10 A
- B. Fan Fuse 10 A
- C. Turn Signal Relay Fuse 10 A
- D. Horn Fuse 10 A
- E. Ignition Fuse 10 A
- F. Headlight Fuse 10 A

- G. Headlight Relay
- H. Headlight Diodes
- I. Starter Diode
- J. Starter Circuit Relay
- K. Interlock Diodes
- L. Taillight Fuse 10 A

15-76 ELECTRICAL SYSTEM

Fuse

30 A Main Fuse Removal

- Remove:
 - Seats (see Frame chapter)
 - Starter Relay and 30 A Main Fuse Connector [A]
- Pull out the main fuse [B] from the starter relay with needle nose pliers.

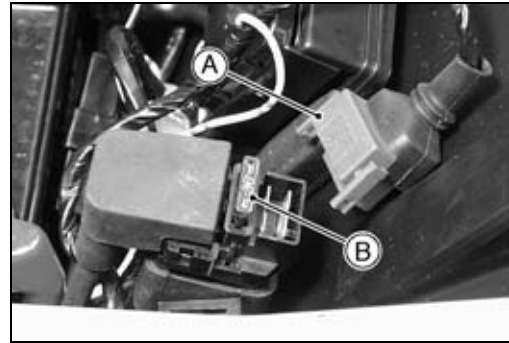

Junction Box Fuse Removal

- Remove the seats (see Frame chapter).
 - Unlock the hook to lift up the lid [A].
 - Pull the fuses [B] straight out of the junction box with needle nose pliers.
- C: Headlight Fuse

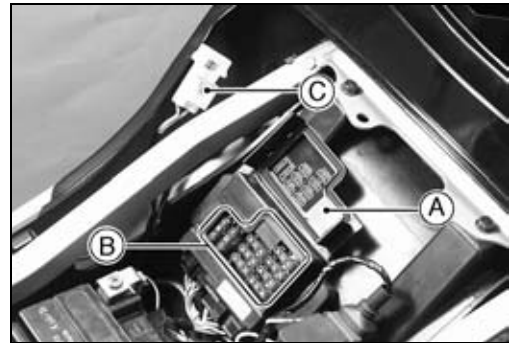

Fuse Installation

- If a fuse fails during operation, inspect the electrical system to determine the cause, and then replace it with a new fuse of proper amperage.
- Install the junction box fuses on the original position as specified on the lid.

Fuse Inspection

- Remove the fuse (see Fuse Removal).
 - Inspect the fuse element.
- ★ If it is blown out, replace the fuse. Before replacing a blown fuse, always check the amperage in the affected circuit. If the amperage is equal to or greater than the fuse rating, check the wiring and related components for a short circuit.
- Housing [A]
Fuse Element [B]
Terminals [C]
Blown Element [D]

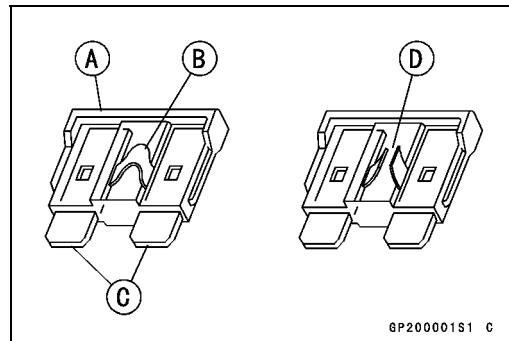

CAUTION

When replacing a fuse, be sure the new fuse matches the specified fuse rating for that circuit. Installation of a fuse with a higher rating may cause damage to wiring and components.

Appendix

Table of Contents

Troubleshooting Guide	16-2
General Lubrication	16-7
Lubrication	16-7
Nut, Bolt, and Fastener Tightness	16-8
Tightness Inspection	16-8
Unit Conversion Table	16-9

16-2 APPENDIX

Troubleshooting Guide

NOTE

○ *This is not an exhaustive list, giving every possible cause for each problem listed. It is meant simply as a rough guide to assist the troubleshooting for some of the more common difficulties.*

Engine Doesn't Start, Starting Difficulty:

Starter motor not rotating:

- Starter lockout switch or neutral switch trouble
- Starter motor trouble
- Battery voltage low
- Starter relays not contacting or operating
- Starter button not contacting
- Wiring open or shorted
- Ignition switch trouble
- Engine stop switch trouble
- Fuse blown

Starter motor rotating but engine doesn't turn over:

- Starter clutch trouble

Engine won't turn over:

- Valve seizure
- Valve lifter seizure
- Cylinder, piston seizure
- Crankshaft seizure
- Connecting rod small end seizure
- Connecting rod big end seizure
- Transmission gear or bearing seizure
- Camshaft seizure
- Starter idle gear seizure

No fuel flow:

- No fuel in tank
- Battery voltage low
- Fuel pump trouble
- Fuel pump relay trouble
- Fuel tank air vent obstructed
- Fuel filter clogged
- Fuel tap clogged
- Fuel line clogged
- Float valve clogged
- Fuel cut valve left close (check fuel cut valve and IC igniter)

Engine flooded:

- Fuel level in carburetor float bowl too high
- Float valve worn or stuck open
- Starting technique faulty
(When flooded, crank the engine with the throttle fully opened to allow more air to reach the engine.)

No spark; spark weak:

- Battery voltage low
- Spark plug dirty, broken, or maladjusted
- Spark plug cap or high tension wiring trouble

- Spark plug cap shorted or not in good contact

- Spark plug incorrect

- IC igniter trouble

- Cam sensor trouble

- Neutral, starter lockout, or sidestand switch trouble

- Crankshaft sensor trouble

- Stick coil trouble

- Ignition or engine stop switch shorted

- Wiring shorted or open

- Fuse blown

Fuel/air mixture incorrect:

- Pilot screw and/or idle adjusting screw maladjusted

- Pilot jet, or air passage clogged

- Air cleaner clogged, poorly sealed, or missing

- Starter jet clogged

Compression Low:

- Spark plug loose

- Cylinder head not sufficiently tightened down

- No valve clearance

- Cylinder, piston worn

- Piston ring bad (worn, weak, broken, or sticking)

- Piston ring/groove clearance excessive

- Cylinder head gasket damaged

- Cylinder head warped

- Valve spring broken or weak

- Valve not seating properly (valve bent, worn, or carbon accumulation on the seating surface)

Poor Running at Low Speed:

Spark weak:

- Battery voltage low

- Spark plug dirty, broken, or maladjusted

- Stick coil wiring trouble

- Stick coil not in good contact

- Spark plug incorrect

- IC igniter trouble

- Crankshaft sensor trouble

- Stick coil trouble

Fuel/air mixture incorrect:

- Pilot screw maladjusted

- Pilot jet, or air passage clogged

- Air bleed pipe bleed holes clogged

- Pilot passage clogged

- Air cleaner clogged, poorly sealed, or missing

- Choke plunger stuck open

- Fuel level in carburetor float bowl too high or too low

- Fuel tank air vent obstructed

Troubleshooting Guide

Fuel cut valve won't fully open (check fuel cut valve and IC igniter)
 Carburetor holder loose
 Air cleaner duct loose
 Air cleaner O-ring damaged
 Fuel pump trouble
 Fuel pump relay trouble
 Fuel filter clogged

Compression low:

Spark plug loose
 Cylinder head not sufficiently tightened down
 No valve clearance
 Cylinder, piston worn
 Piston ring bad (worn, weak, broken, or sticking)
 Piston ring/groove clearance excessive
 Cylinder head warped
 Cylinder head gasket damaged
 Valve spring broken or weak
 Valve not seating properly (valve bent, worn, or carbon accumulation on the seating surface)

Other:

IC igniter trouble
 Carburetor not synchronizing
 Carburetor vacuum piston doesn't slide smoothly
 Carburetor vacuum piston diaphragm damage
 Engine oil viscosity too high
 Drive train trouble
 Brake dragging
 Air suction valve trouble
 Vacuum switch valve trouble

Poor Running or No Power at High Speed:

Firing incorrect:

Spark plug dirty, broken, or maladjusted
 Stick coil wiring trouble
 Stick coil not in good contact
 Spark plug incorrect
 IC igniter trouble
 Crankshaft sensor trouble
 Stick coil trouble

Fuel/air mixture incorrect:

Choke plunger stuck open
 Main jet clogged or wrong size
 Jet needle or needle jet worn
 Air jet clogged
 Fuel level in carburetor float bowl too high or too low
 Fuel cut valve won't fully open (check fuel cut valve)
 Bleed holes of needle jet holder or needle jet clogged

Air cleaner clogged, poorly sealed, or missing
 Air cleaner duct loose
 Air cleaner O-ring damaged
 Water or foreign matter in fuel
 Carburetor holder loose
 Fuel to carburetor insufficient
 Fuel tank air vent obstructed
 Fuel tap clogged
 Fuel line clogged
 Fuel pump trouble
 Fuel pump relay trouble
 Fuel filter clogged

Compression low:

Spark plug loose
 Cylinder head not sufficiently tightened down
 No valve clearance
 Cylinder, piston worn
 Piston ring bad (worn, weak, broken, or sticking)
 Piston ring/groove clearance excessive
 Cylinder head gasket damaged
 Cylinder head warped
 Valve spring broken or weak
 Valve not seating properly (valve bent, worn, or carbon accumulation on the seating surface.)

Knocking:

Carbon built up in combustion chamber
 Fuel poor quality or incorrect
 Spark plug incorrect
 IC igniter trouble

Miscellaneous:

Throttle valve won't fully open
 Carburetor vacuum piston doesn't slide smoothly
 Carburetor vacuum piston diaphragm damaged
 Brake dragging
 Clutch slipping
 Overheating
 Engine oil level too high
 Engine oil viscosity too high
 Drive train trouble
 Air suction valve trouble
 Vacuum switch valve trouble
 Catalytic converters melt down due to muffler overheating (KLEEN)

Overheating:

Firing incorrect:

Spark plug dirty, broken, or maladjusted
 Spark plug incorrect
 IC Igniter trouble

16-4 APPENDIX

Troubleshooting Guide

Muffler overheating:

For KLEEN, do not run the engine even if with only one cylinder misfiring or poor running (Request the nearest service facility to correct it)

For KLEEN, do not push-start with a dead battery (Connect another full-charged battery with jumper cables, and start the engine using the electric starter)

For KLEEN, do not start the engine under misfire due to spark plug fouling or poor connection of the stick coil

For KLEEN, do not coast the motorcycle with the ignition switch off (Turn the ignition switch ON and run the engine)

IC igniter or fuel cut valve trouble

IC igniter trouble

Fuel/air mixture incorrect:

Main jet clogged or wrong size

Fuel level in carburetor float bowl too low

Carburetor holder loose

Air cleaner duct loose

Air cleaner poorly sealed, or missing

Air cleaner O-ring damaged

Air cleaner clogged

Fuel pump trouble

Fuel pump relay trouble

Fuel filter clogged

Compression high:

Carbon built up in combustion chamber

Engine load faulty:

Clutch slipping

Engine oil level too high

Engine oil viscosity too high

Drive train trouble

Brake dragging

Lubrication inadequate:

Engine oil level too low

Engine oil poor quality or incorrect

Oil cooler incorrect:

Oil cooler clogged

Gauge incorrect:

Water temperature meter broken

Water temperature sensor broken

Coolant incorrect:

Coolant level too low

Coolant deteriorated

Cooling system component incorrect:

Radiator fin damaged

Radiator clogged

Thermostat trouble

Radiator cap trouble

Radiator fan switch trouble

Fan motor broken

Fan blade damaged

Water pump not turning

Water pump impeller damaged

Over Cooling:

Gauge incorrect:

Water temperature meter broken

Water temperature sensor broken

Cooling system component incorrect:

Radiator fan switch trouble

Thermostat trouble

Clutch Operation Faulty:

Clutch slipping:

Friction plate worn or warped

Steel plate worn or warped

Clutch spring broken or weak

Clutch hub or housing unevenly worn

No clutch lever play

Clutch inner cable trouble

Clutch release mechanism trouble

Clutch not disengaging properly:

Clutch plate warped or too rough

Clutch spring compression uneven

Engine oil deteriorated

Engine oil viscosity too high

Engine oil level too high

Clutch housing frozen on drive shaft

Clutch hub nut loose

Clutch hub spline damaged

Clutch friction plate installed wrong

Clutch lever play excessive

Clutch release mechanism trouble

Gear Shifting Faulty:

Doesn't go into gear; shift pedal doesn't return:

Clutch not disengaging

Shift fork bent or seized

Gear stuck on the shaft

Gear positioning lever binding

Shift return spring weak or broken

Shift return spring pin loose

Shift mechanism arm spring broken

Shift mechanism arm broken

Shift pawl broken

Jumps out of gear:

Shift fork ear worn, bent

Gear groove worn

Gear dogs and/or dog holes worn

Shift drum groove worn

Gear positioning lever spring weak or broken

Shift fork guide pin worn

Drive shaft, output shaft, and/or gear splines worn

Overshifts:

Gear positioning lever spring weak or broken

Shift mechanism arm spring broken

Troubleshooting Guide

Abnormal Engine Noise:

Knocking:

- IC igniter trouble
- Carbon built up in combustion chamber
- Fuel poor quality or incorrect
- Spark plug incorrect
- Overheating

Piston slap:

- Cylinder/piston clearance excessive
- Cylinder, piston worn
- Connecting rod bent
- Piston pin, piston pin hole worn

Valve noise:

- Valve clearance incorrect
- Valve spring broken or weak
- Camshaft bearing worn
- Valve lifter worn

Other noise:

- Connecting rod small end clearance excessive
- Connecting rod big end clearance excessive
- Piston ring/groove clearance excessive
- Piston ring worn, broken, or stuck
- Piston ring groove worn
- Piston seizure, damage
- Cylinder head gasket leaking
- Exhaust pipe leaking at cylinder head connection
- Crankshaft runout excessive
- Engine mounts loose
- Crankshaft bearing worn
- Primary gear worn or chipped
- Camshaft chain tensioner trouble
- Camshaft chain, sprocket, guide worn
- Air suction valve damaged
- Vacuum switch valve damaged
- Alternator rotor loose
- Catalytic converters melt down due to muffler overheating (KLEEN)

Abnormal Drive Train Noise:

Clutch noise:

- Clutch rubber damper weak or damaged
- Clutch housing/friction plate clearance excessive
- Clutch housing gear worn

Transmission noise:

- Bearings worn
- Transmission gears worn or chipped
- Metal chips jammed in gear teeth
- Engine oil insufficient

Drive line noise:

- Drive chain adjusted improperly
- Drive chain worn
- Rear and/or engine sprocket worn
- Chain lubrication insufficient

Rear wheel misaligned

Abnormal Frame Noise:

Front fork noise:

- Oil insufficient or too thin
- Spring weak or broken

Rear shock absorber noise:

- Shock absorber damaged

Disc brake noise:

- Pad installed incorrectly
- Pad surface glazed
- Disc warped
- Caliper trouble

Other noise:

- Bracket, nut, bolt, etc. not properly mounted or tightened

Oil Pressure Warning Light Goes On:

- Engine oil pump damaged
- Engine oil screen clogged
- Engine oil level too low
- Engine oil viscosity too low
- Camshaft bearing worn
- Crankshaft bearings worn
- Oil pressure switch damaged
- Wiring faulty
- Relief valve stuck open
- O-ring at the oil passage in the crankcase damaged

Exhaust Smokes Excessively:

White smoke:

- Piston oil ring worn
- Cylinder worn
- Valve oil seal damaged
- Valve guide worn
- Engine oil level too high

Black smoke:

- Air cleaner clogged
- Main jet too large or fallen off
- Starter plunger stuck open
- Fuel level in carburetor float bowl too high

Brown smoke:

- Main jet too small
- Fuel level in carburetor float bowl too low
- Air cleaner duct loose
- Air cleaner O-ring damaged
- Air cleaner poorly sealed or missing

Handling and/or Stability

Unsatisfactory:

Handlebar hard to turn:

- Cable routing incorrect
- Hose routing incorrect
- Wiring routing incorrect
- Steering stem locknut too tight

16-6 APPENDIX

Troubleshooting Guide

Steering stem bearing damaged
Steering stem bearing lubrication inadequate
Steering stem bent
Tire air pressure too low

Handlebar shakes or excessively vibrates:

Tire worn
Swingarm pivot bearings worn
Rim warped, or not balanced
Wheel bearing worn
Handlebar clamp bolts loose
Steering stem head nut loose

Handlebar pulls to one side:

Frame bent
Wheel misalignment
Swingarm bent or twisted
Steering maladjusted
Front fork bent
Right and left front fork oil level uneven

Shock absorption unsatisfactory:

(Too hard)
Front fork oil excessive
Front fork oil viscosity too high
Rear shock absorber adjustment too hard
Tire air pressure too high
Front fork bent
(Too soft)
Tire air pressure too low
Front fork oil insufficient and/or leaking
Front fork oil viscosity too low
Rear shock adjustment too soft

Front fork, rear shock absorber spring weak
Rear shock absorber oil leaking

Brake Doesn't Hold:

Air in the brake line
Pad or disc worn
Brake fluid leakage
Disc warped
Contaminated pad
Brake fluid deteriorated
Primary or secondary cup damaged in master cylinder
Master cylinder scratched inside

Battery Trouble:

Battery discharged:

Battery faulty (e.g., plates sulphated, shorted through sedimentation, electrolyte insufficient)
Battery leads making poor contact
Load excessive (e.g., bulb of excessive wattage)
Ignition switch trouble
Alternator trouble
Wiring faulty
Regulator/rectifier trouble

Battery overcharged:

Regulator/rectifier trouble
Battery faulty

General Lubrication

Lubrication

- Before lubricating each part, clean off any rusty spots with rust remover and wipe off any grease, oil, dirt, or grime.
- Lubricate the points listed below with indicated lubricant.

NOTE

○ *Whenever the vehicle has been operated under wet or rainy conditions, or especially after using a high-pressure water spray, perform the general lubrication*

Pivots: Lubricate with Motor Oil.

Rear Brake Rod Joint

Points: Lubricate with Grease.

Clutch Cable Upper and Lower Ends

Throttle Cable Upper Ends

Choke Cable Upper End

Cables: Lubricate with Rust Inhibiter

Choke Cable

Throttle Cables

Clutch Cable

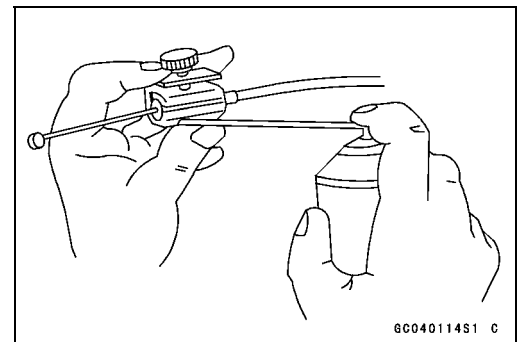

16-8 APPENDIX

Nut, Bolt, and Fastener Tightness

Tightness Inspection

- Check the tightness of the bolts and nuts listed here. Also, check to see that each cotter pin is in place and in good condition.

NOTE

○ *For the engine fasteners, check the tightness of them when the engine is cold (at room temperature).*

- ★ If there are loose fasteners, retorque them to the specified torque following the specified tightening sequence. Refer to the appropriate chapter for torque specifications. If torque specifications are not in the appropriate chapter, see the Standard Torque Table. For each fastener, first loosen it by 1/2 turn, then tighten it.
- ★ If cotter pins are damaged, replace them with new ones.

Nut, Bolt and Fastener to be checked

Wheels:

- Front Axle Nut
- Front Axle Clamp Bolt
- Rear Axle Nut
- Rear Axle Nut Cotter Pin

Brakes:

- Front Master Cylinder Clamp Bolts
- Caliper Mounting Bolts
- Rear Master Cylinder Mounting Bolts
- Brake Lever Pivot Nut
- Brake Pedal Bolt
- Brake Rod Joint Cotter Pin

Suspension:

- Front Fork Clamp Bolts
- Rear Shock Absorber Mounting Nuts
- Swingarm Pivot Shaft Nut
- Uni-Trak Link Nuts

Steering:

- Steering Stem Head Nut
- Handlebar Mounting Bolts

Engine:

- Engine Mounting Bolts
- Exhaust Pipe Mounting Bolt
- Muffler Mounting Nut
- Exhaust Pipe Holder Nuts
- Muffler Body and Exhaust Pipe Connecting Bolts
- Clutch Lever Pivot Nut

Others:

- Sidestand Mounting Bolt
- Footpeg Mounting Bolts
- Footpeg Bracket Mounting Bolts
- Front Fender Mounting Bolts

Unit Conversion Table

Prefixes for Units:

Prefix	Symbol	Power
mega	M	× 1 000 000
kilo	k	× 1 000
centi	c	× 0.01
milli	m	× 0.001
micro	μ	× 0.000001

Units of Mass:

kg	×	2.205	=	lb
g	×	0.03527	=	oz

Units of Volume:

L	×	0.2642	=	gal (US)
L	×	0.2200	=	gal (imp)
L	×	1.057	=	qt (US)
L	×	0.8799	=	qt (imp)
L	×	2.113	=	pint (US)
L	×	1.816	=	pint (imp)
mL	×	0.03381	=	oz (US)
mL	×	0.02816	=	oz (imp)
mL	×	0.06102	=	cu in

Units of Force:

N	×	0.1020	=	kg
N	×	0.2248	=	lb

kg	×	9.807	=	N
kg	×	2.205	=	lb

Units of Length:

km	×	0.6214	=	mile
m	×	3.281	=	ft
mm	×	0.03937	=	in

Units of Torque:

N·m	×	0.1020	=	kg·m
N·m	×	0.7376	=	ft·lb
N·m	×	8.851	=	in·lb

kg·m	×	9.807	=	N·m
kg·m	×	7.233	=	ft·lb
kg·m	×	86.80	=	in·lb

Units of Pressure:

kPa	×	0.01020	=	kg/cm ²
kPa	×	0.1450	=	psi
kPa	×	0.7501	=	cm Hg

kg/cm ²	×	98.07	=	kPa
kg/cm ²	×	14.22	=	psi
cm Hg	×	1.333	=	kPa

Units of Speed:

km/h	×	0.6214	=	mph
------	---	--------	---	-----

Units of Power:

kW	×	1.360	=	PS
kW	×	1.341	=	HP

PS	×	0.7355	=	kW
PS	×	0.9863	=	HP

Units of Temperature:

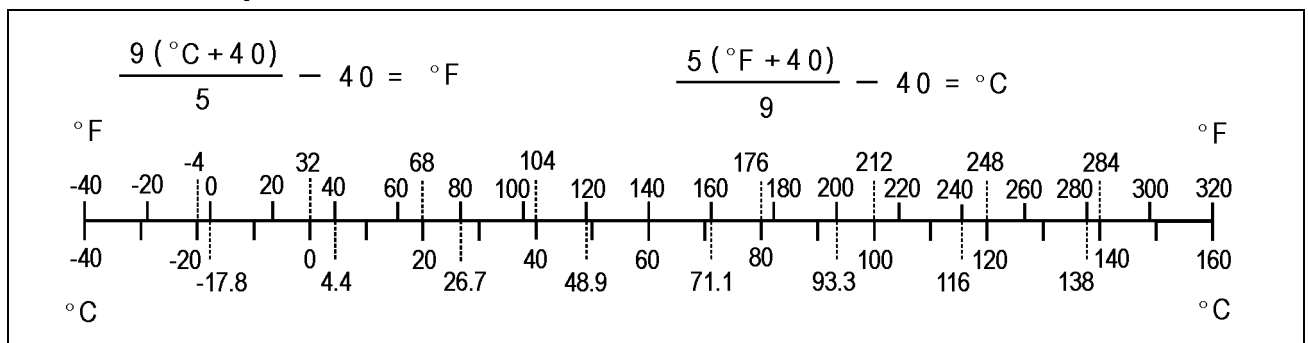

MODEL APPLICATION

Year	Model	Beginning Frame No.
2000	ZX600-J1	JKAZX4J1□YA000001 or JKAZX600JJA000001
2001	ZX600-J2	JKAZX4J1□IA003001 or JKAZX600JJA030001
2002	ZX600-J3	JKAZX4J1□2A048001
2005	ZX600-J4	JKAZX4J1□5A055001
2006	ZX600J6F	JKAZX4J1□6A059001
2007	ZX600J7F	JKAZX4J1□7A065001
2008	ZX600J8F	JKAZX4J1□8A072001

□: This digit in the frame number changes from one machine to another.



KAWASAKI HEAVY INDUSTRIES, LTD.
Consumer Products & Machinery Company

Part No.99924-1254-07

Printed in Japan