



The Valve Train System



Technology
Failure Diagnosis



The content of this brochure is not legally binding and is solely intended for information purposes. Where legally permissible, all liability on the part of Schaeffler Automotive Aftermarket GmbH & Co. KG devolving in connection with this brochure is excluded.

All rights reserved. Any reproduction, distribution, communication, public reproduction, or other publication of this brochure in its entirety or in part is not permitted without prior written consent from Schaeffler Automotive Aftermarket GmbH & Co. KG.

Copyright ©
Schaeffler Automotive Aftermarket GmbH & Co. KG
November 2017

Schaeffler in the Automotive Aftermarket – more innovation, more quality and more service.

Schaeffler in the Automotive Aftermarket – always the first choice for vehicle repair.

Whenever a vehicle needs to go to the garage, our products and repair solutions are first choice to fix them. With our four strong brands LuK, INA, FAG, and Ruville, and our service brand REPERT, we are a reliable partner around the world. Whether passenger cars, light and heavy commercial vehicles, or tractors – our optimally tuned components allow fast and professional parts replacement.

Our products are based on a comprehensive systems approach. Innovation, technical expertise, and the highest material and manufacturing quality make us not only one of the leading development partners for vehicle manufacturers, but also a pioneering provider of value-retaining spare parts and complete repair solutions for clutches and clutch release systems, engine and transmission applications, and chassis applications – always in original-equipment quality. In addition to this, we also offers technical services with our REPERT brand that cover everything having to do with our products and repair solutions.

Know-how of the four key systems of the engine – this is what the brand INA stands for. The product portfolio includes a full range of engine components for the timing drive (for both belt and chain-drive vehicles), for the front end auxiliary drive (FEAD), for the valve train, and the cooling system. The spare part portfolio has both individual products, and solutions that are available in complete KITS and SETs.

Schaeffler REPERT – the service brand for garage professionals.

With REPERT, we offer a comprehensive service package for the products and repair solutions of the LuK, INA, FAG, and Ruville brands. Looking for specific information about damage diagnosis? Are you in need of particular tools to help make your everyday garage routine easier? Whether online portal, service hotline, installation instructions and videos, training seminars, or events – you get all technical services from a single source.

Register now for free, in just a few clicks, at:

www.repxpert.com

SCHAEFFLER
REPERT





Contents		Page
1	Introduction	6
2	The Valve Train	7
2.1	Requirements	7
2.2	Designs	7
2.3	Valve Lash	10
2.4	Valve Lash Adjustment	11
3	Setup and Mode of Operation of the Valve Lash Adjustment Elements	13
3.1	Bucket Tappets	13
3.2	Finger Follower with Pivot Element	15
3.3	Rocker Arm with Insert Element	16
3.4	Roller-Type Swing Arm with Insert Elements	18
3.5	Special Features in the OHV Valve Train	19
3.6	Switchable Valve Lash Adjustment Elements	20
4	High-Pressure Pump Tappets	23
5	Camshaft Phasing Systems	24
5.1	General Information	24
5.2	Overview of Different Concepts for Camshaft Phasing	24
5.3	Function of the Camshaft Phasing System	25
5.4	Camshaft Phasing Units	26
5.5	Control Valve	28
5.6	UniAir	31
6	General Garage Instructions	32
7	Failure Diagnosis and Damage Assessment	34
7.1	General Damage Assessment	34
7.2	Residual Dirt	35
7.3	Failure Diagnosis of Valve Train Components	35

1 Introduction

A certain Christian Reithmann received the first patents for a four-stroke piston engine on October 26, 1860. In these engines, a cam operated the exhaust valve using a ram. The intake valve was “automatically” opened as a result of the vacuum of the intake piston and closed at the end of the intake cycle by a spring. In terms of design, however, these engines could only achieve very low engine speeds. The one cylinder four-stroke engine achieved a maximum engine speed of just 700 rpm in the Daimler Reitwagen, for example.

The Otto engine, which is still well-known today, comes from an invention by Nicolaus August Otto, the co-inventor of the four-stroke process in 1876. Its design at the time was not really similar to today’s engines yet; however, this was the first time valve timing on the intake side was used.

Precise valve lash became more and more important over time during further development of the engines. Mechanical adjustment elements such as the bucket tappet with leveling disc contributed to achieving a better fill level in the cylinder. The Swiss designer Ernest Henry was the inventor of the bucket tappet. He installed it in engines from the French engine and automotive manufacturer Établissements Ballot for the first time in 1919.

The development of hydraulic adjustment elements can be traced back to the early 1930s. At the end of the 1950s, 80 % of all PC engines in the USA were fitted with hydraulic valve lash adjustment elements as standard.

Since the late 1980s, this type of valve lash adjustment has also been the standard for all European vehicle manufacturers.

With variable valve timing, the engineers developed an option for regulating the control times or the valve stroke to meet the requirements of the market and increase the efficiency of the engines.

In 1989, Honda launched its VTEC engine onto the Japanese market – one of the first vehicle manufacturers to introduce this type of product. In 1990 it was launched on the American market and in 1990/91 on the European market.

Vehicle manufacturers now offer different technical solutions, each with their own designations (e.g. BMW-VANOS, MG Rover-VVC, Fiat-MultiAir), for variable valve timing.

Today, all these systems have become established on the market and are subject to continuous further development and optimization.



2 The Valve Train

A combustion engine must be supplied with fuel and air cyclically, whilst the exhaust gas resulting from combustion has to be expelled. This process is known as charge change. During this charge change, the intake and exhaust channels of the cylinders are periodically opened and closed by the intake and exhaust valves.

The intake and exhaust valves fulfill the following tasks in the process:

- Open up as large an opening cross section as possible
- Execute the opening and closing processes quickly
- Have a flow-optimized shape to keep any pressure loss low
- Achieve a good seal when closed
- Exhibit good stability under load

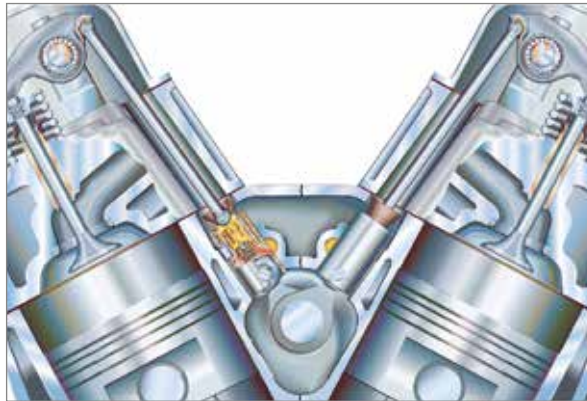

Fig. 1: Overhead valves (OHV)

OHV refers to an engine in which the camshaft is installed under the separator line of the cylinder head and cylinder block.

2.1 Requirements

The valve train is subject to high accelerations and decelerations. The associated inertial forces increase as the engine speed increases and stress the structure to a high extent. In addition, the exhaust valves must withstand the high temperatures of the exhaust gases. To be able to work correctly under these conditions, the components of the valve train must:

- Remain stable over the entire service life
- Run with a low level of friction in their guides
- Guarantee sufficient heat conduction away from the valves (in particular, away from the exhaust valves)

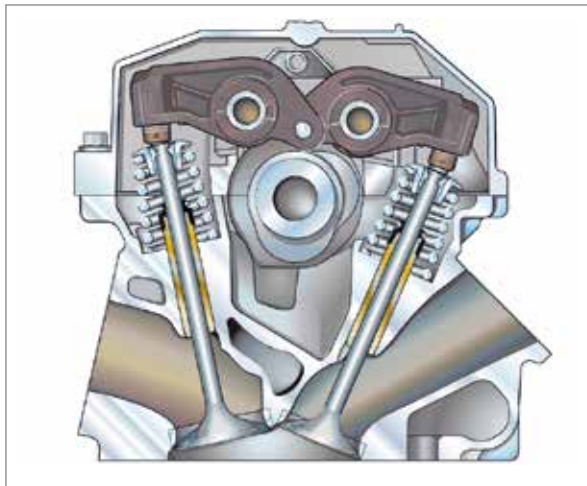

Fig. 2: Overhead camshaft (OHC)

Engines in which the camshaft is arranged above the separator line of the cylinder head and cylinder block are referred to as OHC.

2.2 Designs

The engine configuration determines the design of the valve train. What all valve trains have in common though is the drive above the camshaft. Valve trains are differentiated according to:

- The number of valves that they actuate; and
- The number and location of the camshafts through which they are actuated

Camshafts can be installed at two points in the engine; they are designated accordingly as bottom-mounted or overhead camshafts.

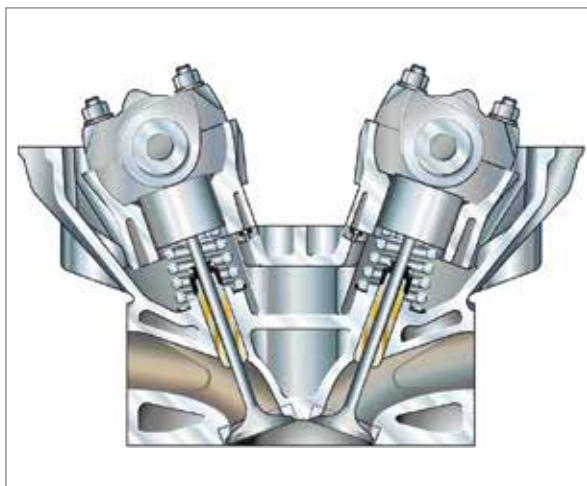

Fig. 3: Double overhead camshaft (DOHC)

Engines with two camshafts above the separator line of the cylinder head and cylinder block are known as DOHC.

Camshaft

Camshafts are manufactured in three different procedures. The design used most frequently is a camshaft manufactured from cast iron. The steel camshaft is another popular design. It is used when specific material is required. Here the camshaft is milled from a steel billet and then honed. The third design is known as the assembled camshaft. It is usually manufactured from a cylindrical pipe that the individual cams are pushed onto. The cams are fastened using welding or shrink fitting, for example.

The modular structure and the significantly lower weight of the assembled camshaft in comparison to a cast iron camshaft is a big advantage.

The cams arranged on the camshaft actuate the intake and exhaust valves. This converts the rotational movement of the camshafts into a straight-line movement of the valves.

Different design variants of cam followers (bucket tappets, finger followers, rocker arms, etc.) are used between the cams and the valves.



Types of valve timing systems

OHV valve train

Figure 4:

In the OHV valve train, many transmitting parts are necessary to transmit the cam lift to the valve – ram, pushrod, rocker arm, rocker arm bearing unit. With the further development of the engines, the engine speeds became higher and higher, and the aim was to make the engines more powerful, more compact and lighter. The OHV pushrod valve train soon reached its engine speed limits due to its only moderate overall rigidity. As a consequence, the number of moving valve train parts had to decrease.

Figure 5:

The camshaft was shifted to the cylinder head meaning that the pushrod was no longer required.

OHC valve train

Figure 6:

In the OHC valve train, the camshaft is arranged further up in the cylinder head, meaning there is no ram and the cam lift can be transmitted directly via the rocker arm or finger follower.

Figure 7:

Due to the central arrangement of the camshaft, this finger follower train has the largest structural rigidity.

Figure 8:

OHC valve trains, whose valves are actuated directly via bucket tappets, are suitable for maximum engine speeds. There are also no rocker arms or finger followers here.

Today, all types of valve timing systems (Figures 4 to 8) can be found in high-volume production engines. Depending on the design focus – power rating, torque, displacement etc. – the engineers must weigh up the advantages and disadvantages and decide on one type, meaning that all valve train controls are justified, from the pushrod valve train to the compact OHC valve train with directly actuated valves.

Fig. 4



Fig. 5



Fig. 6



Fig. 7



Fig. 8



2.3 Valve Lash

A valve train system must have a defined clearance – the valve lash – when the valve is closed. This compensates for changes in the sizes of the components during driving operations.

Possible causes for these changes in size are:

- Temperature fluctuations in the different components in the engine (e.g. in the cylinder head)
- The use of different materials with different thermal expansion coefficients
- Wear on the contact points between the camshaft and valve

Possible effects of incorrect valve lash are:

Insufficient valve lash

Valve opens earlier and closes later

- Due to the shortened closing time, not enough heat can be emitted from the valve disc to the valve seat.
- The valve disc of the exhaust valve overheats, causing the mechanical resilience of the valve to reduce and the valve can tear off.
- There is a risk that the exhaust valve or intake valve does not fully close if the engine is warm.
- On the exhaust valve exhaust gas is drawn in, and at the same time, flames on the intake valve fire back into the intake duct.
- Gas and power losses occur, engine power reduces. The consequences are worse emission values!
- The valves are overheated by the hot exhaust gases constantly flowing past, which causes the valve discs and valve seats to burn.

Excessive valve lash

Valve opens later and closes earlier

- The result is shorter opening times and smaller opening cross-sections.
- The fill level of the cylinder with ignitable fuel mixture decreases. The consequences are worse emission values!
- The engine torque and the engine power reduce.
- High mechanical stress on the valve.
- Noise generated in the valve train.
- The valve shaft is deformed on the contact surface to the adjusting element.

2.4 Valve Lash Adjustment

With mechanical valve lash adjustment, the valve lash must be adjusted manually according to defined maintenance intervals, e.g. using adjusting screws or leveling disks in the mechanical bucket tappet.

The hydraulic valve lash adjustment takes place via hydraulic bucket tappets, finger followers, rocker arms or swing arms for example and automatically keeps the valve lash at zero when the engine is running.

Hydraulic valve lash adjustment sink-down phase

The cam is in the lift phase, the valve is open - for component designation please see figures 9 and 10.

The hydraulic valve lash adjustment element is loaded by the force of the engine valve springs and the inertial forces. This shortens the distance between the piston and inner housing accordingly.

As a result, a small amount of oil is pressed out of the high-pressure chamber through a leakage gap and fed back into the reservoir. At the end of the sink-down phase, a small valve lash is created. If there is any air in the adjustment element, this small amount of oil-air mixture is pressed out via the discharging hole and the guide gap.

Sink-down phase

According to the basic principle, the hydraulic process in the inside of the adjustment elements is identical for all elements and is therefore shown here as an example on one variant.

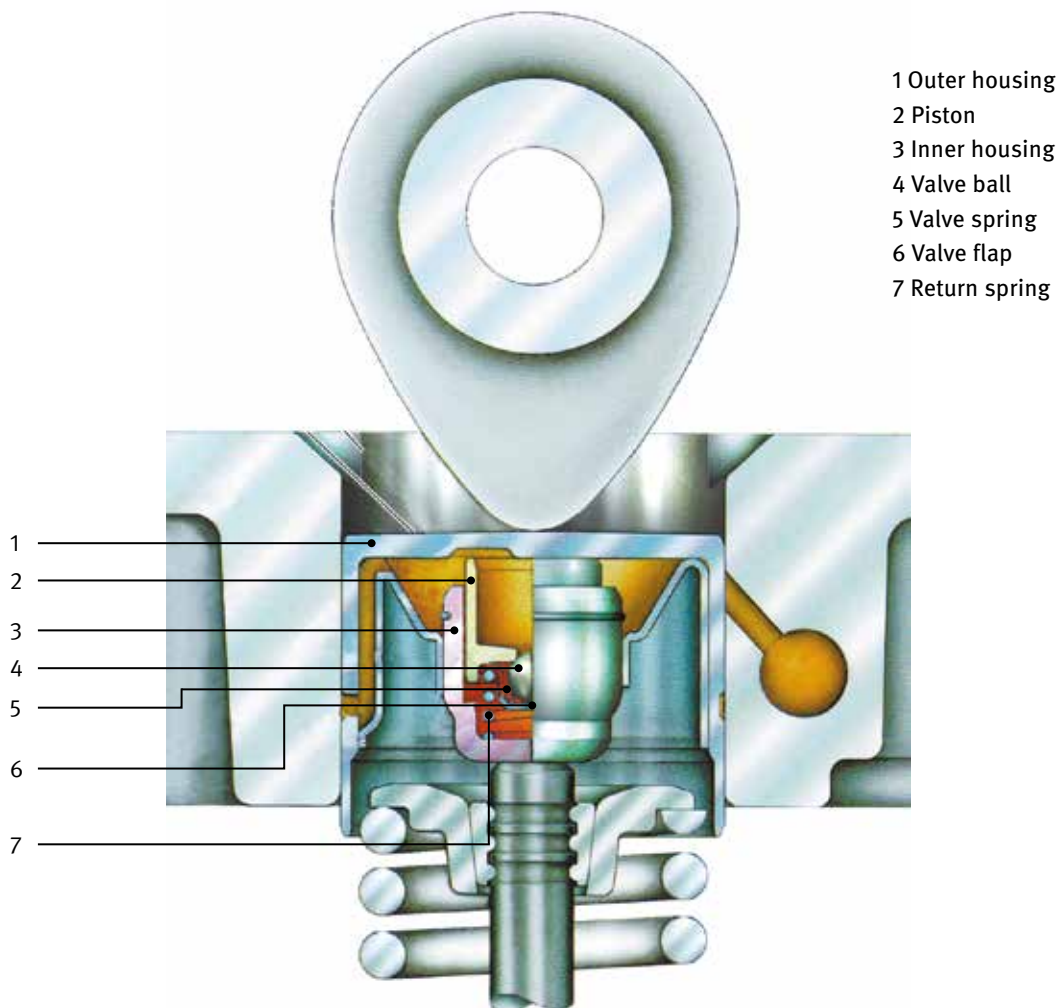

Fig. 9: Sink-down phase

Adjustment phase

The cam is in the base circle phase, the valve is closed – for component designation please see figures 9 and 10.

The return spring presses the the piston and inner housing apart until the valve lash is balanced. The non-return valve opens due to the differential pressure between the high-pressure chamber and reservoir.

Oil flows from the reservoir into the high-pressure chamber via the non-return valve. The non-return valve closes and the force transmission in the valve train is reestablished.

Adjustment phase

According to the basic principle, the hydraulic process in the inside of the adjustment elements is identical for all and is therefore shown here as an example on one variant.

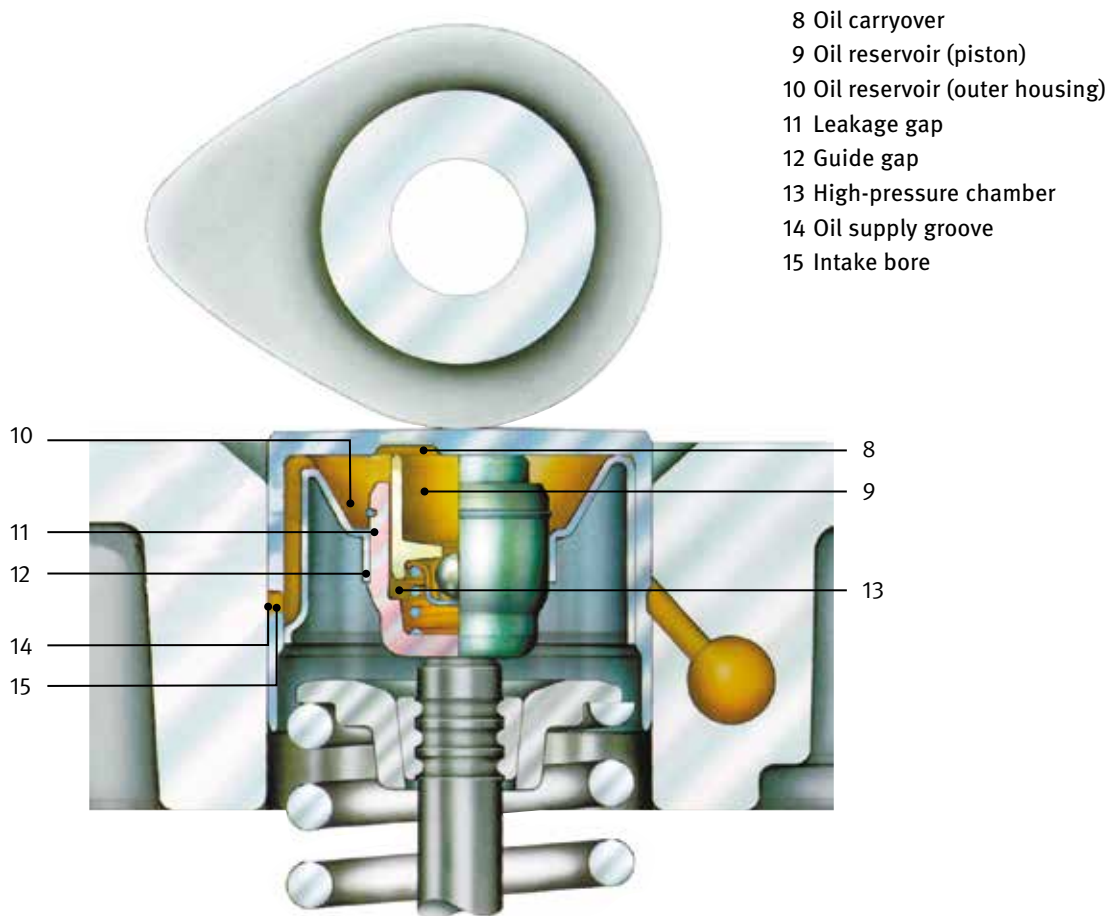

Fig. 10: Adjustment process

3 Setup and Mode of Operation of the Valve Lash Adjustment Elements

3.1 Bucket Tappets

In the case of a valve train with a bucket tappet, no transmission link is needed between the intake/exhaust valve and the camshaft. The cam stroke is transmitted directly to the valve via the base of the bucket tappet.

Frictional losses occur on the contact surface between the cam and the base of the bucket tappet, known as the sliding transfer point. However, these losses can be kept to a minimum using a suitable material pairing or friction-reducing coatings.

To further reduce the wear that occurs, the cam is ground at an angle and attached opposite the bucket tappet laterally offset so that the bucket tappet is turned by a certain angle at every actuation.

These direct drives are distinguished by very high rigidity and at the same time, small moving masses. This makes them particularly suitable for engines with high engine speeds.

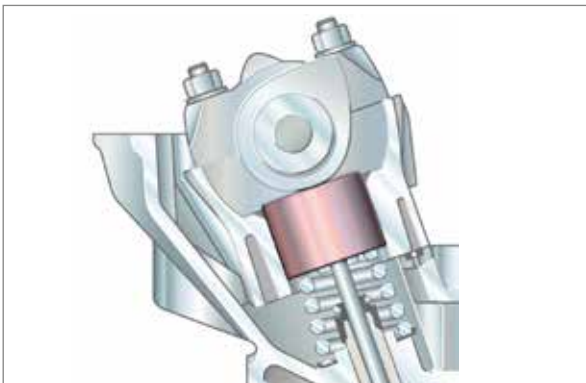

Fig. 11: Bucket tappet valve train

Mechanical bucket tappet

There must always be a defined valve lash between the cam base circle and the base of the bucket tappet. This balances out the changes in length of the valve train due to thermal expansion. Therefore, for mechanical bucket tappets, a basic setting must always be performed. If the valve lash changes during driving operations due to normal wear, it must be reset.

Mechanical bucket tappet with top leveling disc

The defined valve lash is determined via the leveling disc loosely inserted in the main body. If the valve lash does not correspond to the specifications of the vehicle manufacturer, a leveling disc of corresponding thickness must be inserted. The camshaft does not have to be removed for the exchange.



Fig. 12:
Mechanical bucket tappet
with top leveling disc

Mechanical bucket tappet with bottom leveling disc

Here too, the thickness of the leveling disc determines the defined valve lash. However, this leveling disc is located under the base of the bucket tappet. The camshaft must therefore be removed to change the leveling disc. The low mass of this design variant reduces the valve spring forces and the frictional power. In addition, the whole surface of the outer base of the bucket tappet can be used as a contact area for the cam.



Fig. 13:
Mechanical bucket tappet
with bottom leveling disc

Mechanical bucket tappet with graduated base thickness

In this design there are no longer separate leveling discs. The valve lash is set through bucket tappets with different base thicknesses. To achieve this, the camshaft must be removed and a bucket tappet with the corresponding base thickness fitted. Its low mass reduces the valve spring forces and the frictional power. In addition, the whole surface of the base of the bucket tappet can also be used as a contact area for the cam.



Fig. 14:
Mechanical bucket tappet
with graduated base thick-
ness

Hydraulic bucket tappet

Hydraulic bucket tappets balance the valve lash during engine operation automatically. They are maintenance-free and are distinguished by a very high valve train rigidity. The whole valve train is very quiet due to the consistent valve lash and the exhaust emissions are equally low over the whole life.

The different variants may have the same dimensions on the outside but are completely different in the "inner workings". Consequently, it is not easy to exchange hydraulic bucket tappets.

Reasons for this are:

- Different sink-down times of the hydraulic adjustment elements
- Designed to a certain oil specification
- Different surface finish of the base of the bucket tappet (e.g. hardened or nitrided)
- Different oil pressure
- Type of bucket tappet (anti-drain, with bottom air intake or with labyrinth)
- Different spring forces of the non-return valve
- Different strokes

Hydraulic bucket tappet with anti-drain protection

No oil can escape from the outer reservoir of the bucket tappet during the standstill phase of the engine due to the anti-drain protection. This means that a certain oil volume is always available, thereby improving the start-up behavior after a longer standstill.

Hydraulic bucket tappet with bottom air intake

Here, the oil is drawn in from the bottom via a riser duct. This means that no air gets into the adjustment element and the oil reservoir volume can be used more efficiently. Start-up behavior after a longer standstill is also improved here.

Hydraulic bucket tappet with labyrinth

The hydraulic bucket tappet with labyrinth is a combination of the two designs with anti-drain protection and bottom air intake.

3CF bucket tappet (3CF = cylindrical cam contact face)

The shape of the cam contact surface of this bucket tappet enables a more effective opening and closing acceleration of the intake and exhaust valves. An anti-rotation mechanism ensures that the cam contact surface of the bucket tappet is always in the optimal position for camshaft cams. In addition, the oil intake bore is always located at the same point. This simplifies the oil supply and reduces the oil throughput.

Switchable bucket tappet

Switchable bucket tappets are used in engines with cam profile switching. Depending on the load condition of the engine, two strictly defined valve stroke curves can be alternated. This lowers the fuel consumption significantly.

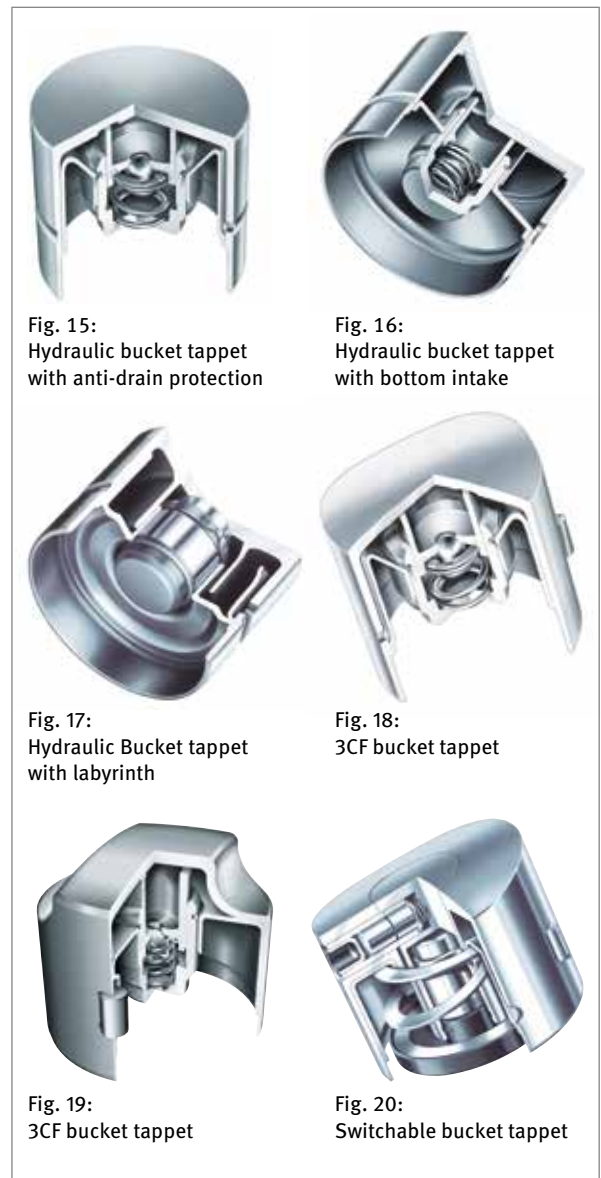

3.2 Finger Follower with Pivot Element

Finger followers are made from sheet steel or cast steel. Contact with the cam is usually provided by a roller with rolling bearings. Therefore, we also refer to roller-type finger followers in this context. In comparison to bucket tappets, short levers produce smaller moments of inertia. Designs with smaller masses reduced on the valve side can be realized. However, finger followers are vastly inferior to bucket tappets in terms of rigidity.

The different valve train designs require differently shaped cams. If you compare the cams for a bucket tappet valve train with those used for roller-type finger follower valve trains, the latter have a larger tip radius as well as concave flanks and produce a smaller cam lift, depending on the transmission ratio. The camshaft is located above the roller, which should preferably be located half-way between the valve and the pivot element. This layout makes the finger follower particularly useful for four-valve diesel engines.

In these engines, the valves are arranged either in parallel or at a slight angle to each other so that a sufficiently large distance is created between the camshafts only through the use of finger followers.

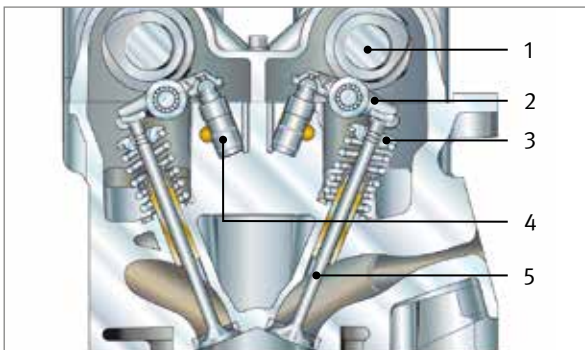

Fig. 21: Valve train with roller-type finger follower

- 1 Camshafts
- 2 Roller-type finger follower
- 3 Valve spring
- 4 Hydraulic pivot element
- 5 Valve

Finger follower

In all designs, the contact between the finger follower and the cam is preferably via a cam roller with rolling bearings. Thanks to its compact construction, only a small mounting space is required and the assembly in the cylinder head is very easy. The required oil can be supplied very easily to a finger follower and the friction in the valve train is very low.



Fig. 22: Finger follower

Sheet steel finger follower

There are no restrictions to the height of the guide brackets in which the valve is guided. The finger follower can be designed with or without oil spray nozzles or with or without safety clips. The latter simplifies assembly in the cylinder head.



Fig. 23: Sheet steel finger follower

Cast finger follower

The cast finger follower enables a very complex component geometry, which enables an especially high resilience. Depending on the design, it has a very low mass moment of inertia and high rigidity.



Fig. 24: Cast finger follower



Fig. 25: Hydraulic pivot element

Hydraulic pivot element

The difference between the different hydraulic pivot elements is mainly in the sink-down time, exactly like in the hydraulic bucket tappets.

If a hydraulic pivot element with an incorrect sink-down time is fitted, this can lead to substantial malfunctions in the valve train or even cause serious engine damage.

In principle, the finger follower and hydraulic pivot element should always be replaced in pairs. Otherwise, an unfavorable contact ratio between the socket of the finger follower and the head of the pivot element occurs, resulting in high wear.

3.3 Rocker Arm with Insert Element

In rocker arm valve trains, the camshaft is located beneath the rocker arm on one of its ends. The cam lift is transmitted to the lever via a sliding tap or a roller (roller-type finger follower). Cam rollers based on a needle bearing are used in modern rocker arms to keep the frictional losses low. At the other end of the rocker arm there is a hydraulic insert element for automatic valve lash adjustment or an adjusting screw for mechanical adjustment of the valve lash. The intake or exhaust valve is actuated via this rocker arm end.

The contact point between the adjustment element (insert element) and the valve must always be on the valve shaft end. As the rocker arm performs an oscillatory movement, the contact surface of the insert element to the valve actuation element is slightly curved (spherical). This results in a very small supporting surface which in turn leads to a comparably large unit pressure at the valve shaft end. If this is very high, insert elements with a swivel base or slide shoe are used. The swivel base (or slide shoe) is connected to the insert element via a ball joint and is therefore always level on the valve shaft end. This produces a larger contact surface and the unit pressure decreases.

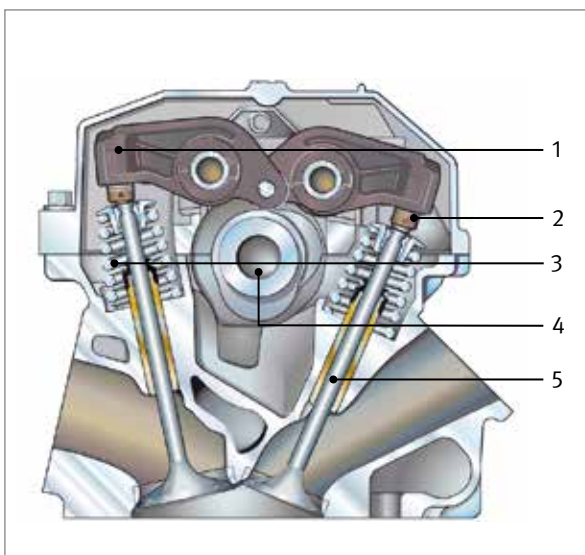

Fig. 26: Valve train with rocker arm

- 1 Rocker arm
- 2 Hydraulic insert element
- 3 Valve spring
- 4 Camshaft
- 5 Valve

The **hydraulic insert element** automatically adjusts the valve lash and thus enables consistently low exhaust emissions over the entire service life. It operates very quietly and is also maintenance-free. Oil is supplied to the insert element via bores in the rocker arm axle.



Fig. 27: Hydraulic insert element

The main body of the **rocker arm** is generally made of aluminum. Inside there is a cam roller based on a needle bearing on one end and at the other end, the hydraulic insert element. A big advantage of a valve train with rocker arms is its very low friction. In addition, it takes up little space because all valves can be actuated by one camshaft.

A **hydraulic insert element without slide shoe** is distinguished in particular by its low weight and therefore a low moving mass.



Fig. 28: Hydraulic insert element without slide shoe

The **hydraulic insert element with slide shoe** is pivot-mounted on the insert element via a ball/crown joint. This results in a very low unit pressure in the contact to the valve. The slide shoe is made from hardened steel.

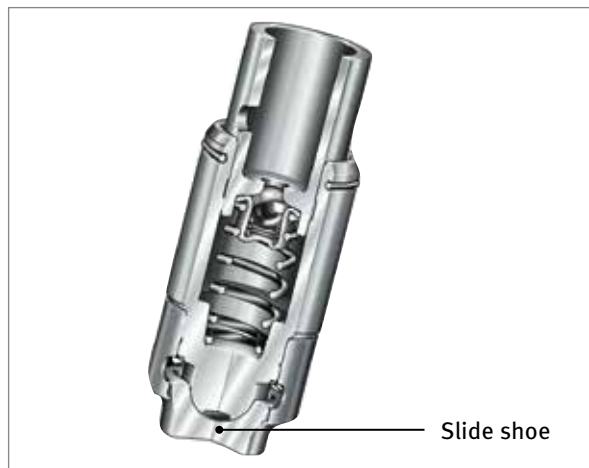

Fig. 29: Hydraulic insert element with slide shoe

3.4 Roller-Type Swing Arm with Insert Elements

In swing arm valve trains the camshaft is positioned above the swing arm and can actuate several valves simultaneously. The valves are actuated via two cams that act on two or three insert elements via two rollers in the arm. The design with two insert elements is referred to as a double swing arm, and the design with three elements is a triple swing arm. This principle is used in multi-valve diesel engines. Even if these engines have a rotated valve arrangement, it is still possible to actuate all valves via just one camshaft. At the same time, this arrangement leaves enough space for the injection nozzles.



Fig. 30: Roller-type swing arm with insert elements

The main body of the **roller-type swing arm** is generally made of aluminum. Inside there are cam rollers based on needle bearings and a separate hydraulic insert element for each valve. The roller-type swing arm is also distinguished by low frictional power and is extremely speed-resistant.

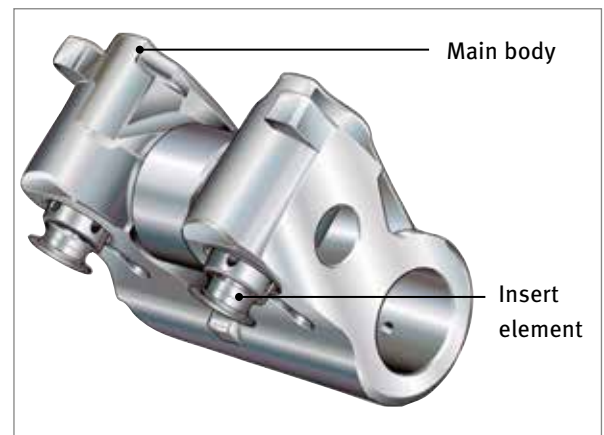

Fig. 31: Double swing arm

Here too, the **hydraulic insert elements** automatically adjust the valve lash and thus enable consistently low exhaust emissions over the entire service life. They also operate very quietly and are maintenance-free. Oil is supplied to the insert elements via bores in the roller-type swing arm.

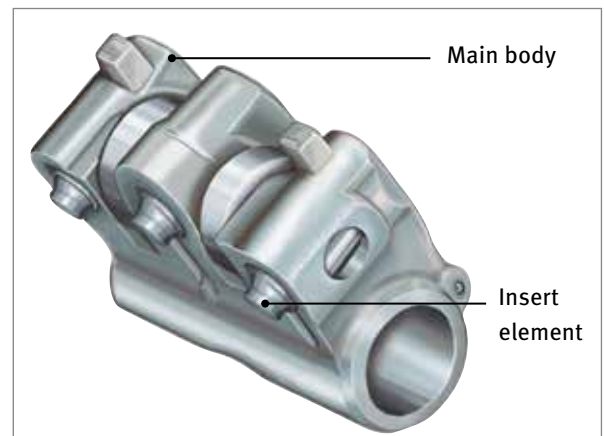

Fig. 32: Triple swing arm

3.5 Special Features in the OHV Valve Train

In engines with a bottom-mounted camshaft, the distance between the cam and lever is relatively large. In this case, a pushrod transmits the stroke movement to the lever. Pushrods are used in combination with special cam followers or tappets.

These establish the contact to the cam either via a sliding contact surface (flat or mushroom tappets) or via a roller (roller tappet) and also have the task of guiding the pushrod.

- 1 Hydraulic roller tappet
- 2 Rocker arm
- 3 Cam roller
- 4 Housing
- 5 Piston
- 6 Anti-rotation mechanism
- 7 Pushrod
- 8 Rocker arm bearing unit
- 9 Needle roller bearing

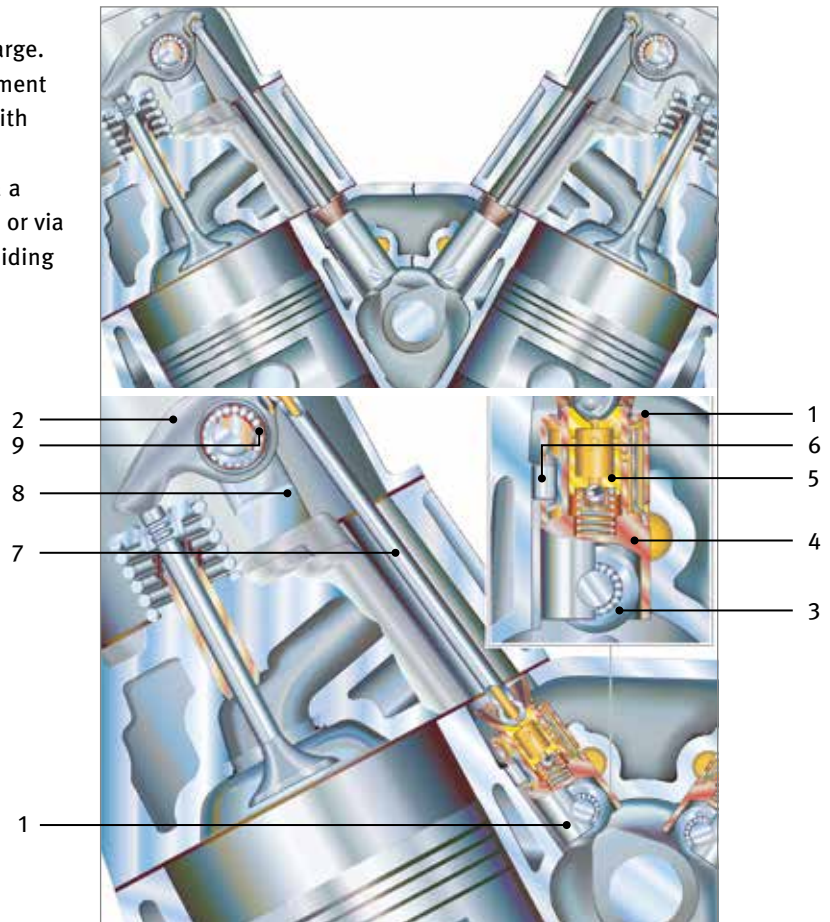

Fig. 33: OHV valve train

Hydraulic roller tappets with a labyrinth have a special internal oil supply system. It improves the emergency running properties even if the pressure oil supply is not optimal. The automatic valve lash adjustment also enables consistently low exhaust emissions over the entire service life here. These tappets also operate very quietly and are maintenance-free.

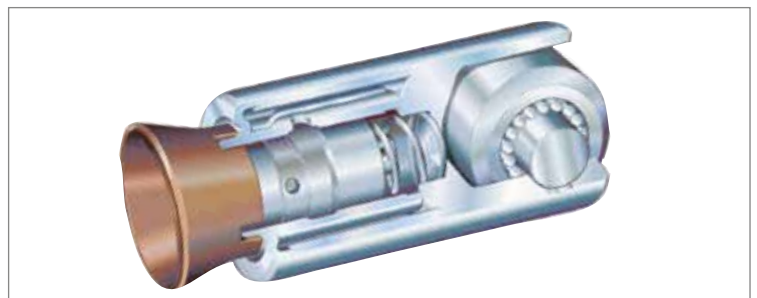

Fig. 34: Hydraulic roller tappet

Rocker arms with a rocker arm bearing unit are supplied as a complete arm/arm bearing support assembly unit. The rocker arm is supported with a needle roller bearing on the rocker arm bearing unit that allows it to swivel. Its movement is therefore very low-friction.

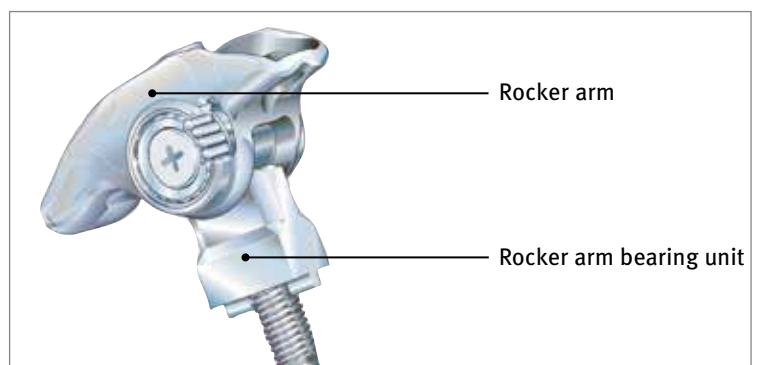

Fig. 35: Rocker arm with rocker arm bearing unit

3.6 Switchable Valve Lash Adjustment Elements

The tighter specifications for exhaust emissions and the requirement for lower fuel consumption along with greater driving comfort, which is expressed in variables such as power rating, torque and response characteristics of the engine, require particular variability of the valve train.

Today, cam profile switching systems with corresponding cam followers such as switchable rocker arms, finger followers or bucket tappets have already been realized. The cam profile switching is used to realize different valve lift curves depending on the point of operation, i.e. to set the respective optimum valve stroke. The prerequisite for this is that there is also a corresponding cam available as a lifting element for each alternative valve stroke – unless the alternative is the zero lift, that is the shutting down of the valve. In the process the element meshed with the valve is supported on the base circle cam.

The cylinder deactivation or valve shutdown is used mainly in large-volume multi-cylinder engines (with e.g. eight, ten or twelve cylinders). The aim of this process is to minimize the charge change losses (pump or throttle losses) or to shift the point of operation. Due to the even firing sequences, popular V8 and V12 engines can be "shifted" to R4 or R6 machines. Trials on a V8 engine in stationary operation show that using cylinder deactivation in common driving cycles leads to fuel savings of between 8% and 15%. In order to shut down a valve, a second stroke cam per cam follower is sacrificed.

In this case, the element which taps the stroke from the cam is uncoupled from the valve. The movement of the tappet misses the mark, and therefore this is also referred to as a "lost-motion" stroke. As there is no longer any link to the valve spring, the mass inertia forces occurring must be absorbed by another spring (known as the "lost-motion" spring). The part of the valve train for which no shutdown or cylinder deactivation is planned executes the stroke movement unchanged. On the deactivated cylinders, the camshaft now only works against the "lost-motion" spring forces, which are smaller than the corresponding valve spring forces by a factor of four or five. This reduces frictional losses.



Fig. 36: Switchable mechanical bucket tappet

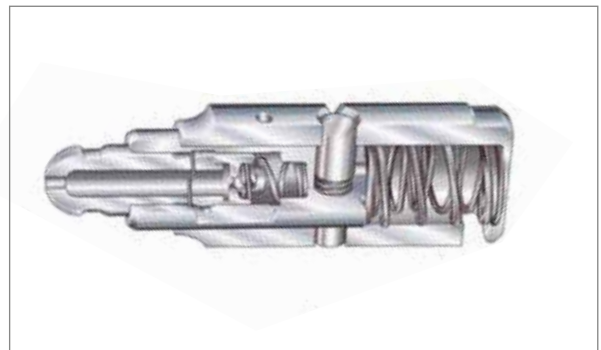

Fig. 37: Switchable pivot element

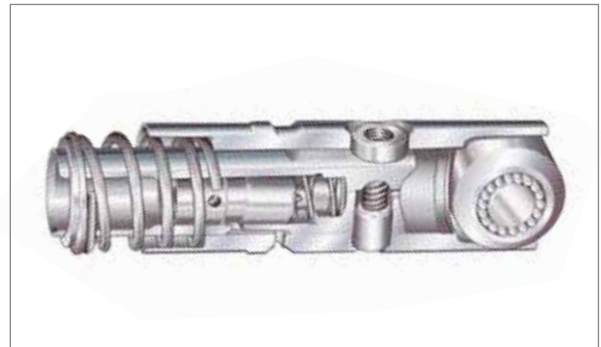

Fig. 38: Switchable roller tappet

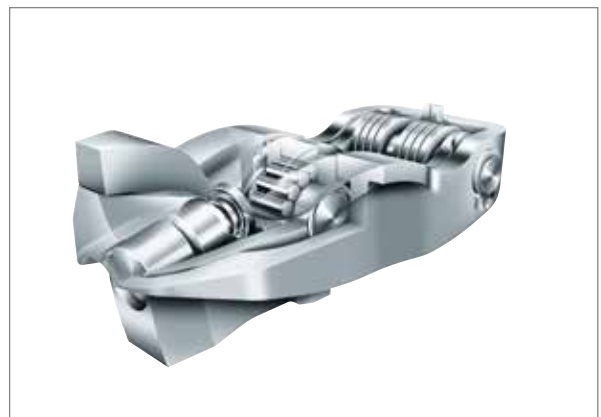

Fig. 39: Switchable roller-type finger follower

Function of the switchable bucket tappet

Base circle phase (shifting process)

- The support spring presses the outer tappet against the inner tappet stop.
- The inner tappet is in contact with the inner cam; there is low clearance between the outer cam and the outer tappet.
- At reduced engine oil pressure, the spring-supported locking piston links the outer tappet to the inner tappet.
- If the engine oil pressure becomes greater than the switching oil pressure, the actuator piston presses the locking piston back into the outer tappet. This decouples the outer tappet from the inner tappet.
- The hydraulic adjustment element in the inner tappet balances the valve lash.

Cam lift phase, unlocked (zero or low lift)

- The outer cam pair moves the outer tappet downwards against the support springs.
- The engine valve follows the contour of the inner cam.
- If all engine valves in a cylinder are deactivated (outer tappet unlocked), the cylinder can be switched off. This reduces the fuel consumption considerably.

Cam lift phase, locked (full lift)

- The outer cam pair moves the outer tappet and inner tappet, which are locked together, downwards and opens the engine valve.
- The hydraulic adjustment element is loaded.
- A small amount of oil from the high-pressure chamber is pressed out of the leakage gap.
- After reaching the base circle phase, the valve lash is set to zero.

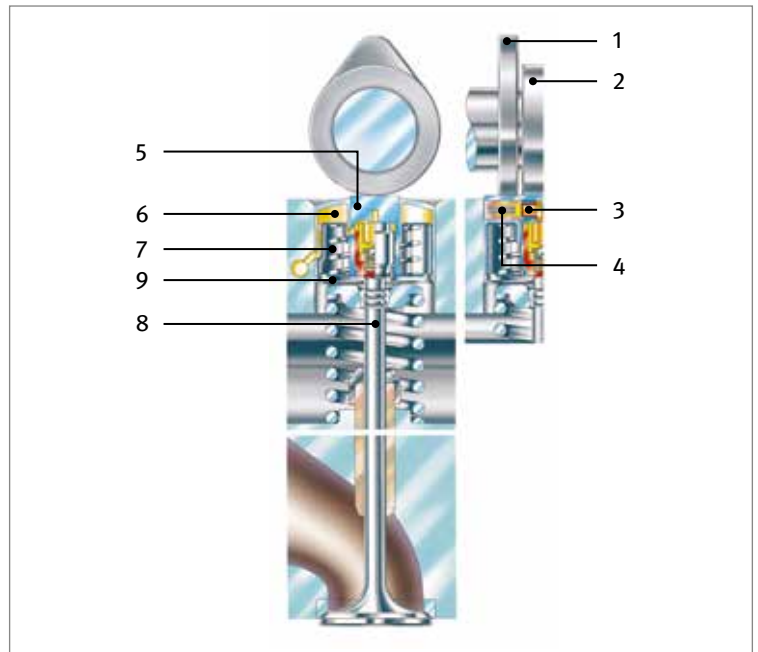

- 1 Outer cam
- 2 Inner cam
- 3 Actuator piston
- 4 Locking piston
- 5 Inner tappet
- 6 Outer tappet
- 7 Support spring

- 8 Adjustment element
- 9 Support plate
- 10 Guide groove
- 11 Anti-rotation pin

- Engine oil pressure throttled
- Oil under engine oil pressure
- Oil under high pressure

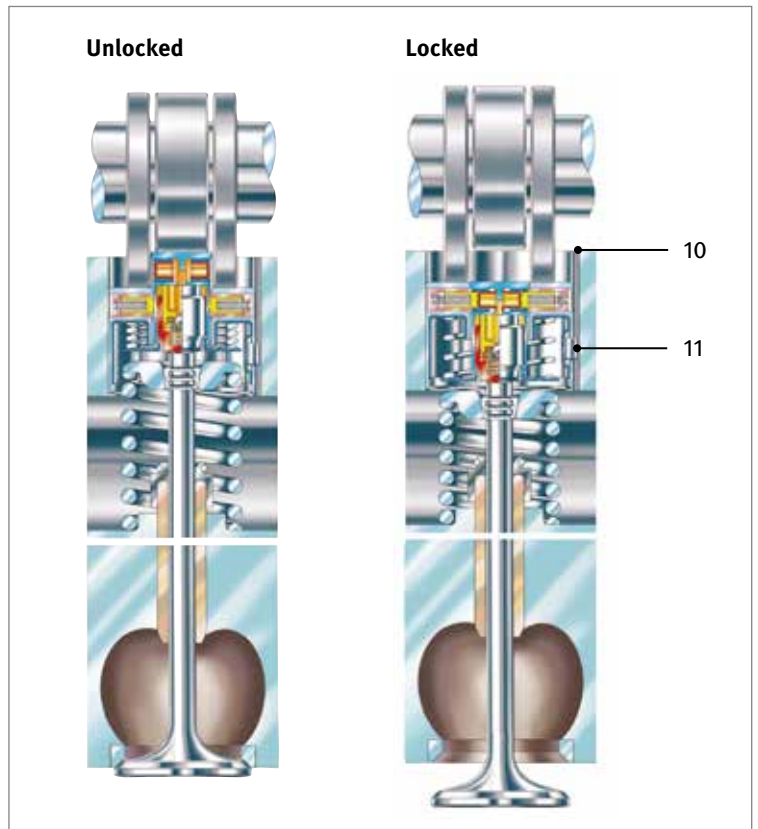

Fig. 40 and 41: Switchable bucket tappet

Operating principles of switchable valve train elements

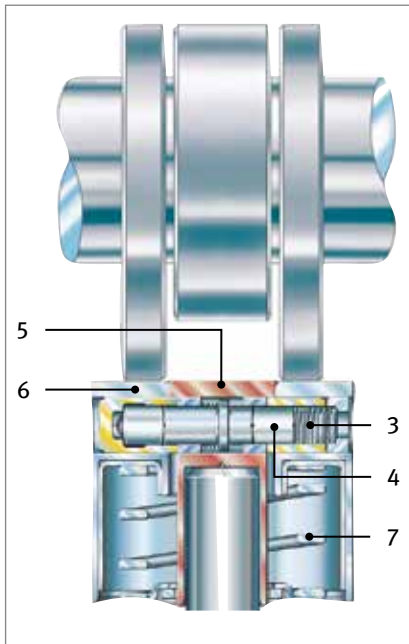

Fig. 42: Base circle phase

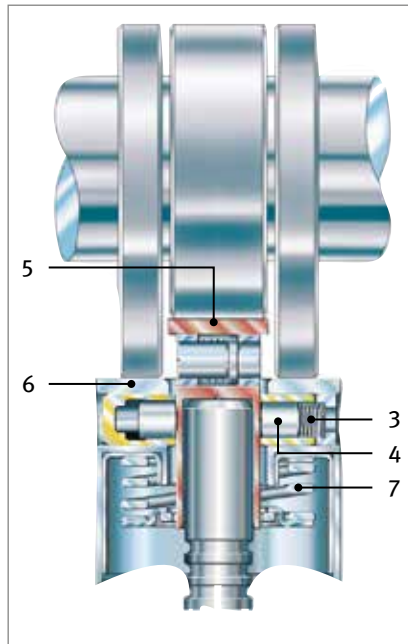

Fig. 43: Cam lift phase, unlocked (low lift)

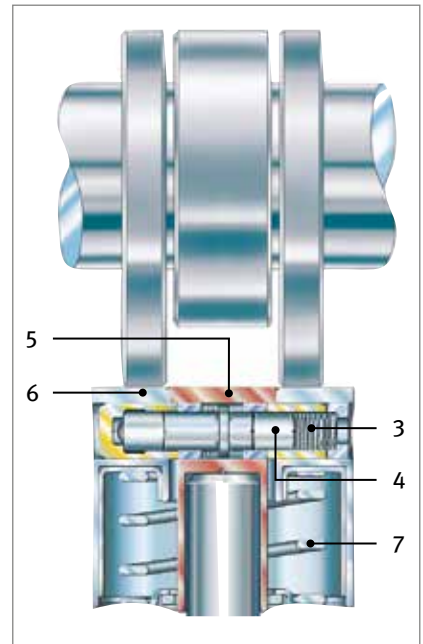

Fig. 44: Cam lift phase, locked (full lift)

1 Piston
2 Cam roller

3 Return spring
4 Locking piston

5 Inner tappet
6 Outer tappet

7 Support spring
("lost-motion" spring)

Locked (full lift)

Unlocked (zero lift)

Locked (full lift)

Unlocked (zero lift)

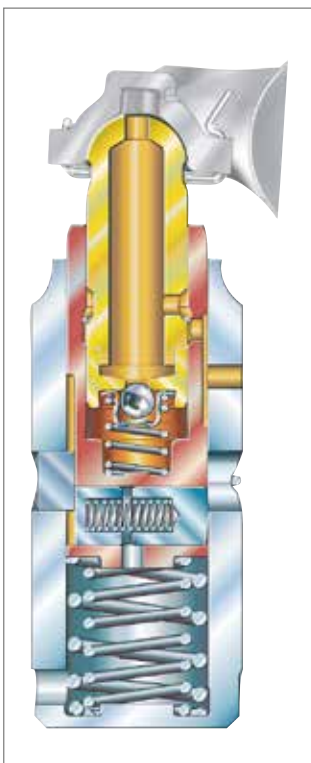
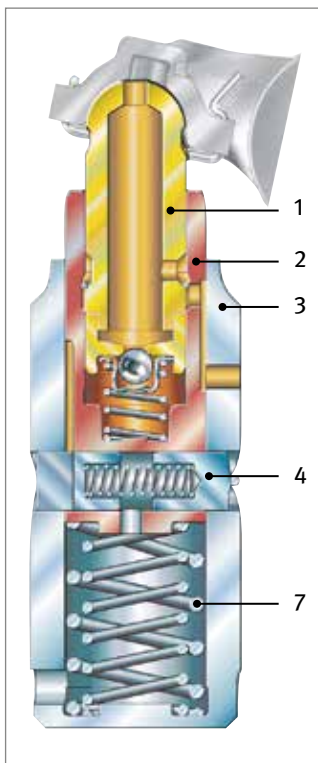

Fig. 45 and 46: Switchable pivot elements

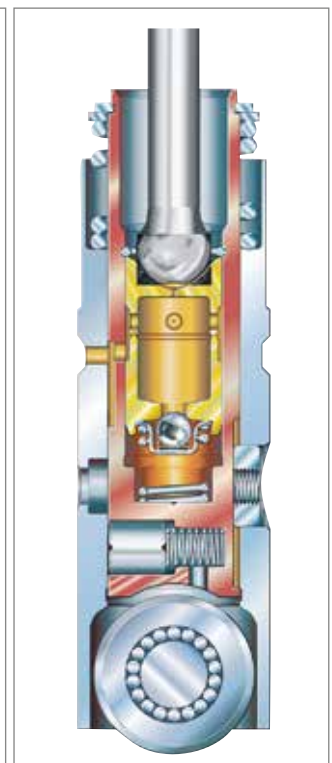
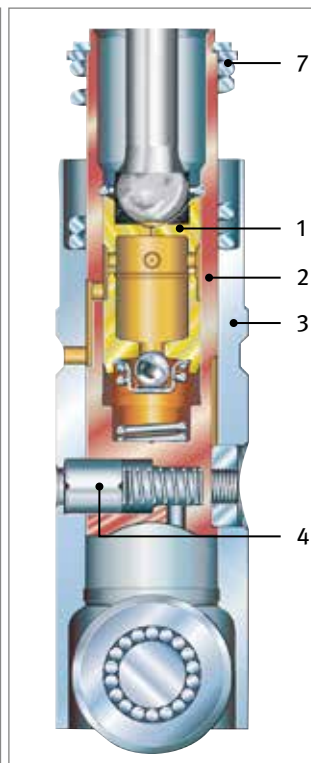

Fig. 47 and 48: Switchable roller tappet

4 High-Pressure Pump Tappets

High-pressure pump tappets are used in virtually all gasoline engines that feature direct gasoline injection. The pump tappet converts the rotational movement of the camshaft into a straight-line movement of the pump piston and drives the high-pressure fuel pump. The drive takes place via a separate cam on the camshaft.

A high-pressure pump with a pump tappet is typically used for three- and four-cylinder in-line engines. Eight- and ten-cylinder V-engines with two high-pressure pumps require two pump tappets accordingly. Six-cylinder engines can have either one or two high-pressure fuel pumps.

The high-pressure pump tappet with sliding contact surface

Can be used for injection pressures of up to approx. 150 bar



Fig. 49: High-pressure pump tappet with sliding contact surface

A high-pressure pump tappet with cam roller

Can be used for injection pressures of up to approx. 200 bar



Fig. 50: High-pressure pump tappet with cam roller

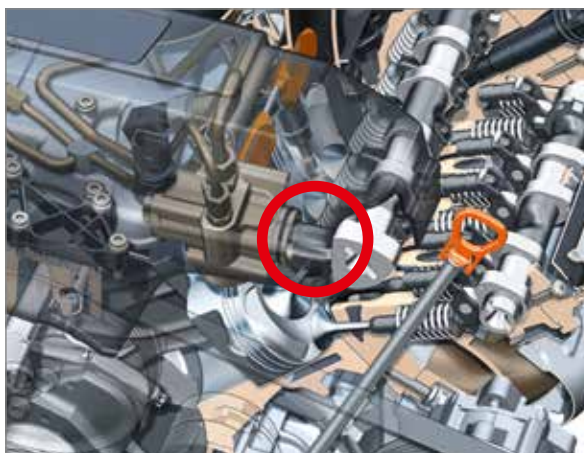

Fig. 51: Example installation position in the vehicle

5 Camshaft Phasing Systems

5.1 General Information

The aim of the camshaft phasing is to achieve as optimal a combustion as possible by changing the valve timing. An adjustment of the camshaft to the intake side or to the exhaust side or a combination of the two is possible. Typical adjustment angles for the camshaft are between 20° and 30°. The camshaft phasing systems are used in belt and chain drive engines. Different compact designs meet different mounting space requirements. By adjusting the camshaft, not only are the exhaust emissions reduced and fuel consumption lowered, but the torque and power rating are also increased.

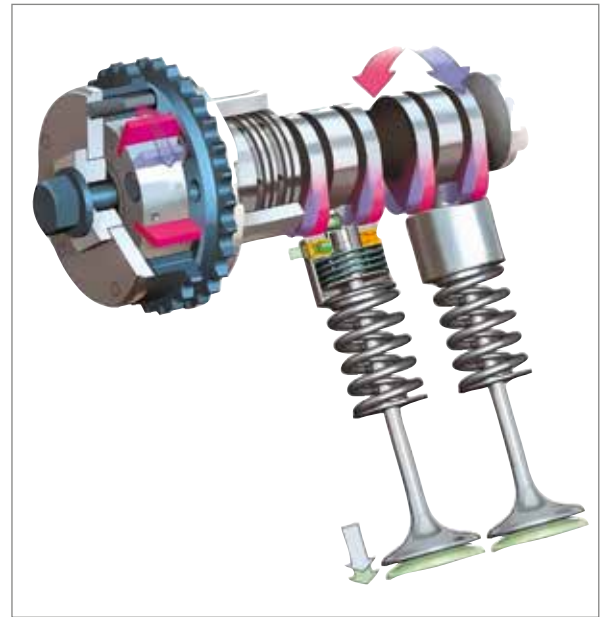

Fig. 52: Camshaft phasing system

5.2 Overview of Different Concepts for Camshaft Phasing

Different phasing unit concepts have different benefits:

Concept	Benefits	Stroke curves of the gas exchange valves
Intake camshaft phasing	<ul style="list-style-type: none"> • Reduced emissions • Reduced fuel consumption • Improved comfort (decrease in idle speed) • Increased torque and power 	<p>The diagram shows the intake valve stroke curve (red solid line) shifted to the right (advanced) compared to its regulated position (dotted green line). The exhaust valve curve (blue dashed line) remains in its regulated position. The x-axis is labeled with EO, IO, EC, and IC.</p>
Exhaust camshaft phasing	<ul style="list-style-type: none"> • Reduced emissions • Reduced fuel consumption • Improved comfort (decrease in idle speed) 	<p>The diagram shows the exhaust valve stroke curve (red solid line) shifted to the left (retarded) compared to its regulated position (dotted green line). The intake valve curve (blue dashed line) remains in its regulated position. The x-axis is labeled with EO, IO, EC, and IC.</p>
Independent camshaft phasing of intake and exhaust camshaft (DOHC)	<ul style="list-style-type: none"> • Reduced emissions • Reduced fuel consumption • Improved comfort (decrease in idle speed) • Increased torque and power 	<p>The diagram shows both the intake (red solid line) and exhaust (blue dashed line) valve stroke curves shifted from their regulated positions (dotted green lines). The intake curve is shifted right and the exhaust curve is shifted left. The x-axis is labeled with EO, IO, EC, and IC.</p>
Synchronous camshaft phasing of intake and exhaust camshaft (DOHC/SOHC)	<ul style="list-style-type: none"> • Reduced emissions • Reduced fuel consumption 	<p>The diagram shows both the intake (red solid line) and exhaust (blue dashed line) valve stroke curves shifted together from their regulated positions (dotted green lines). The x-axis is labeled with EO, IO, EC, and IC.</p>

- Phasing unit in retarded position
- - - - - Phasing unit in advanced position
- Regulated position (phasing unit is kept at one angle position)

- EO → Exhaust open
- EC → Exhaust closed
- IO → Intake open
- IC → Intake closed

5.3 Function of the Camshaft Phasing System

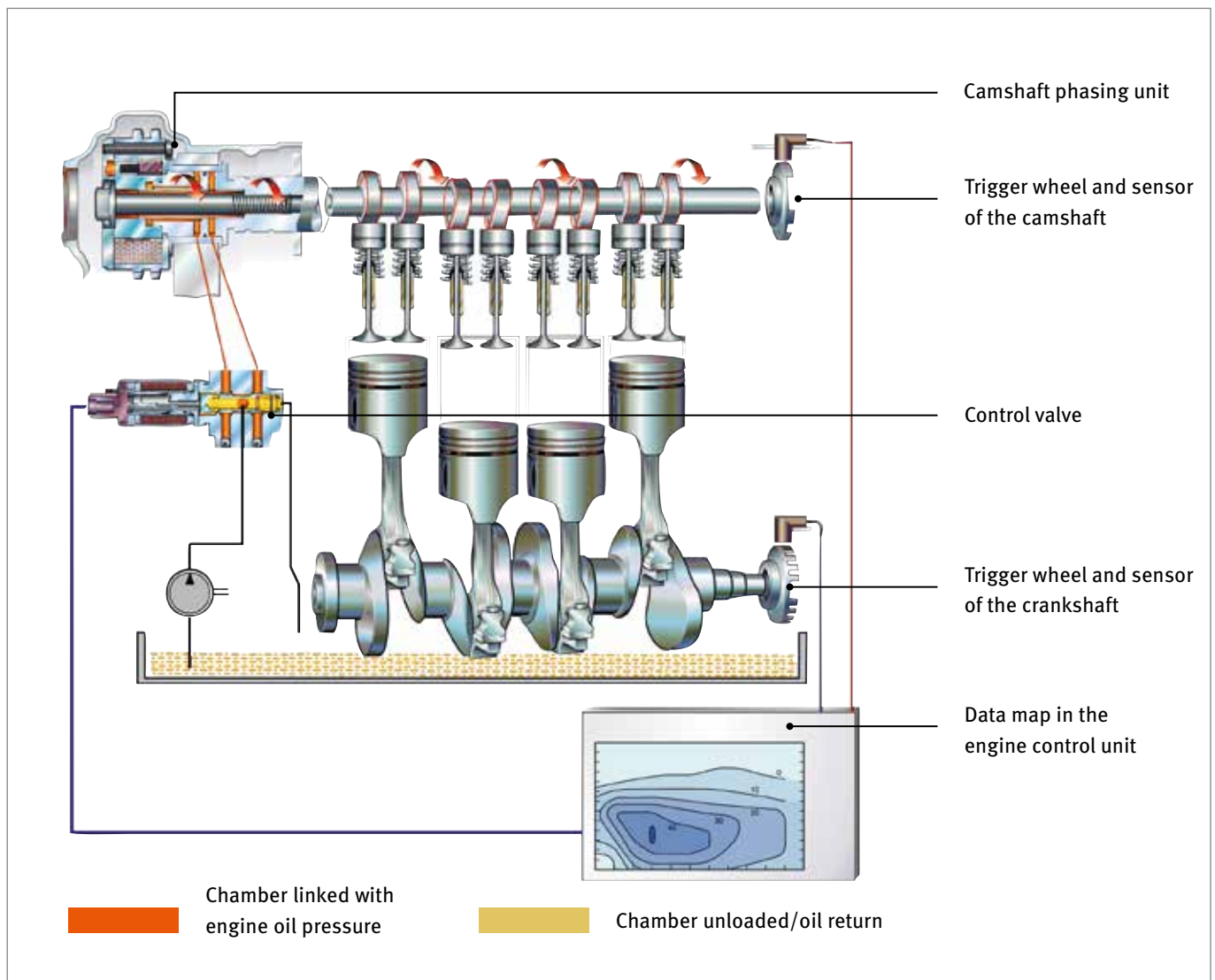

Fig. 53: Camshaft phasing system

Camshaft phasing – control loop

The camshaft is continually adjusted in a closed control loop using the engine oil pressure.

- The desired angle for the valve timing is stored in the data map of the engine control unit depending on the load condition, the temperature and the speed of the engine.
- The actual angle is calculated in the engine control unit from the signals from the camshafts and crankshaft sensors and is permanently compared with the desired angle at a high frequency.
- If the desired angle and actual angle differ from each other, the current at the control valve is changed so that engine oil flows into the oil chamber to be increased in size in the camshaft phasing unit and out of the oil chamber to be reduced.
- A relative torsion of the camshaft to the crankshaft or a displacement of the timing to an earlier or later opening and closing time occurs dependent on the oil volume flowing.

5.4 Camshaft Phasing Units

Vane-type camshaft phasing unit

There are vane-type camshaft phasing units for both chain and belt timing valves. The stator is linked to the crankshaft by the timing chain or the timing belt. A central screw or a central valve links the rotor to the camshaft. The rotor is positioned twist-mounted between two end stops in the stator.

The torque is transferred from the stator to the rotor via the hydraulically clamped "vanes". In combination with segments in the stator, they form oil chamber pairings which are completely filled with oil during operation. The usual number of vanes is between three and five and depends on the requirement of the adjusting speed and the loads on the whole system.

A locking element links the drive and the power take-off together mechanically during the start-up process of the engine. It is hydraulically unlocked as soon as the phasing unit is to be adjusted out of the basic position.

The vane-type camshaft phasing unit must be 100% tight in the belt drive. By contrast, small leakages are not a problem for the chain drive as the whole chain drive itself runs in oil.

Rotor phasing unit

The rotor phasing unit is the current design variant of a camshaft phasing unit. The rotor and vanes are made from one piece in contrast to the vane-type camshaft phasing unit. Spring-loaded seal lips seal the chambers from each other. The function is identical to the vane-type phasing unit.

Smart phaser

Current camshaft phasing units will no longer be sufficient for future engines. Due to lower engine oil pressures, the oil chambers can no longer be filled quickly enough. This is where the newly developed smart phaser will be used. Technically, it corresponds to the rotor phasing unit but in addition it has an oil reservoir with a non-return valve. This reservoir ensures that the oil chambers are always filled at the required speed.



Fig. 54: Chain timing drives

- | | |
|------------------------|-------------------|
| 1 Stator (drive wheel) | 3 "Vanes" |
| 2 Rotor (drive hub) | 4 Locking element |



Fig. 55: Belt timing drives



Fig. 56: Rotor phasing unit

Intake phasing

Phasing unit in basic position

- The valve timing is located, as shown in the image below, in the "retarded" position.
- The locking element is engaged.
- At the same time, oil pressure in the oil chamber loads the "vanes" on one side and holds them on the end stop.
- The control valve is de-energized.

Phasing unit in controlled operation

- The control valve is exposed to current.
- Oil is directed into the second chamber (5).
- The oil unlocks the locking element there and twists the rotor.
- This action shifts the camshaft into the "advanced" position.

Exhaust phasing

Phasing unit in basic position

- The valve timing is usually in the "advanced" position. Therefore in exactly the opposite position to that shown below.
- The locking element is engaged.
- The control valve is de-energized.

Phasing unit in controlled operation

- The control valve is exposed to current.
- Oil is directed into the second chamber.
- The oil unlocks the locking element there and twists the rotor.
- This action shifts the camshaft into the "retarded" position.
- The friction drag at the camshaft has a braking effect in the "retarded" direction.
- The spiral spring has a larger torque than the frictional torque of the camshaft.
- The spiral spring is suspended in the cover and connected with the rotor in the center via a mounting plate.

To hold it in an intermediate position, the control valve is brought into the control position on the intake and exhaust sides. All oil chambers are therefore largely completely closed. Only the oil leakages that can potentially occur are balanced.

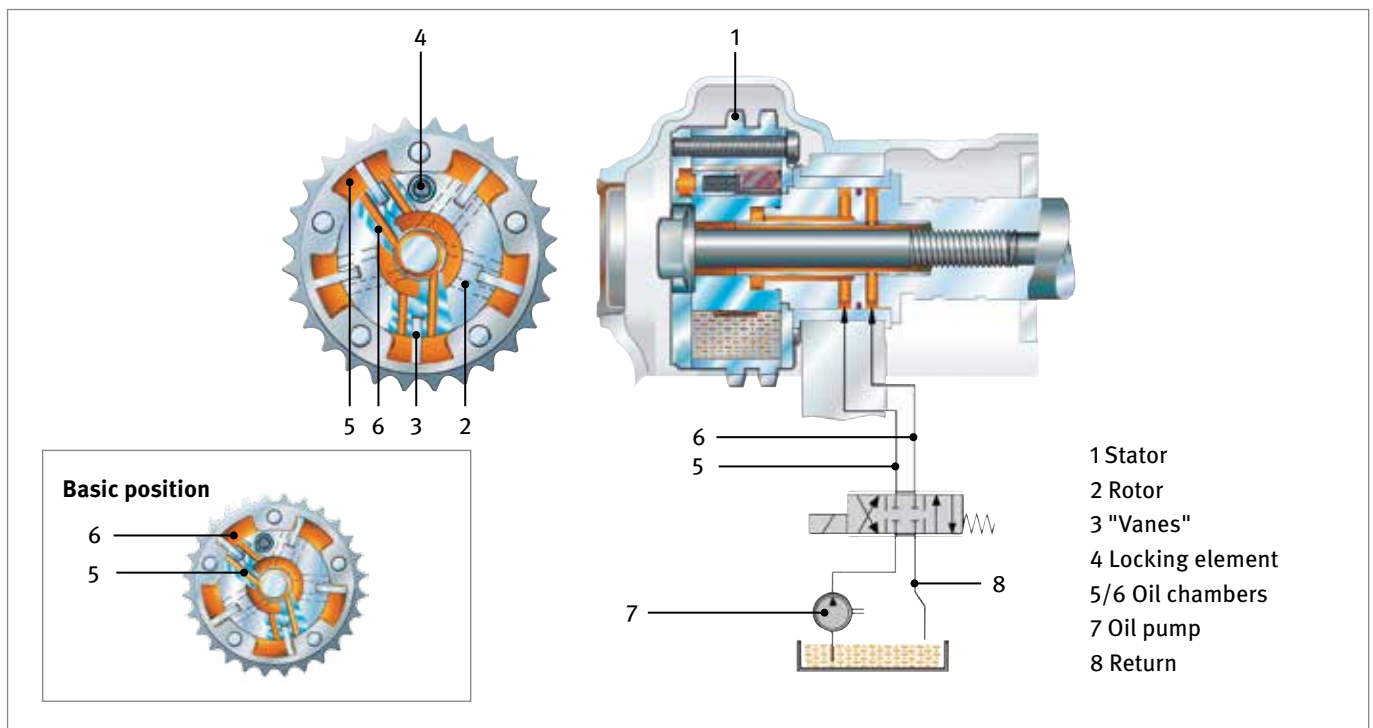

Fig. 57: Camshaft phasing in control position

5.5 Control Valve

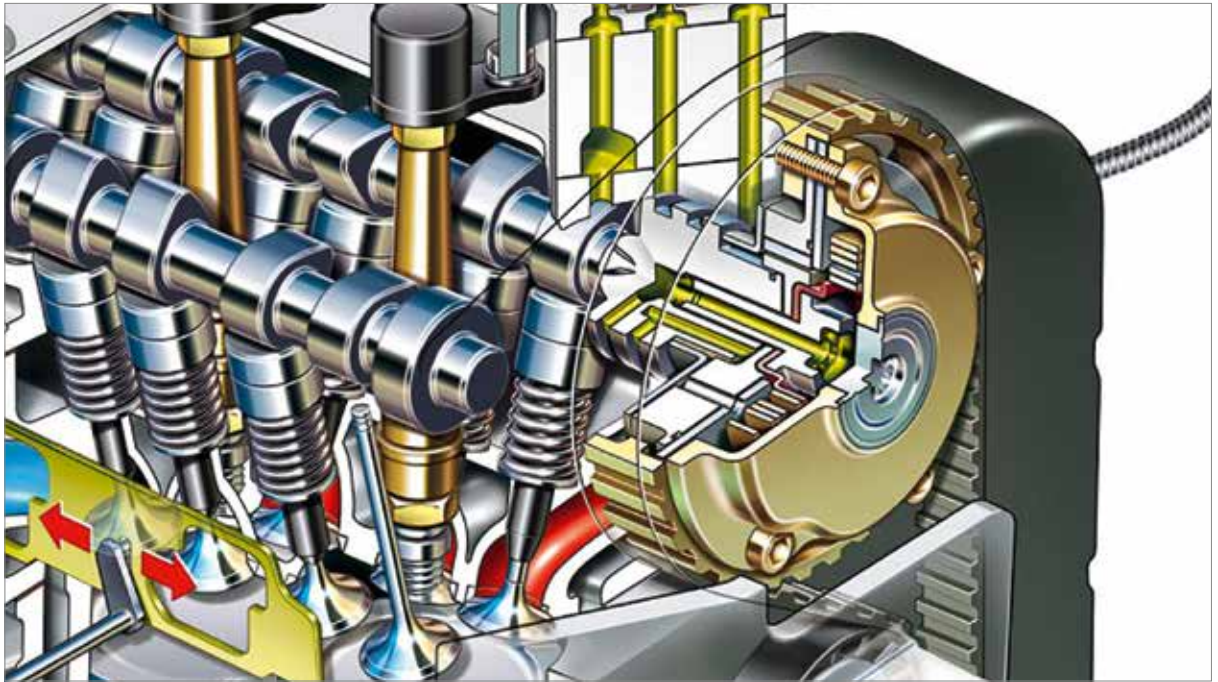

Fig. 58: Valve train section

Design as an insert valve

The insert valve can be integrated directly in the cylinder head or attached using an intermediate housing. It has a modular structure despite its compact construction and allows modifications for adaptation to the respective application. It is connected to the engine control unit electrically.

The insert valve is designed as a proportional valve with four connections.

Design as a central valve

The central valve is screwed into the camshaft. The separate central magnet is positioned coaxially in front of the central valve. Short oil flow distances between the central valve and camshaft phasing unit ensure low oil pressure losses and high adjusting speeds.

The central valve is designed as a proportional valve with five connections.

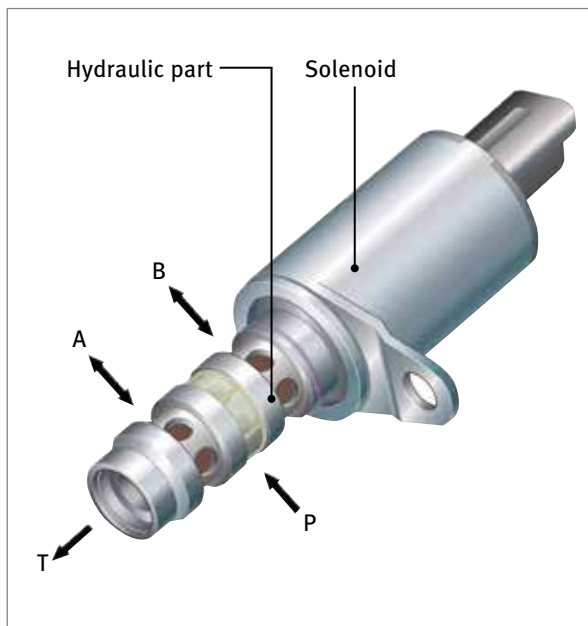

Fig. 59: Insert valve

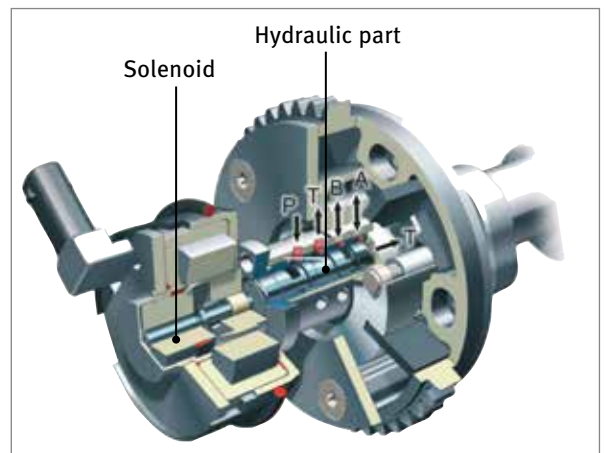

Fig. 60: Central valve

Connections of the control valves:

- Oil pump "P"
- 2x return "T"
- Working chamber "A" of the camshaft phasing unit
- Working chamber "B" of the camshaft phasing unit

Function of the control valve

When current is applied to the solenoid, the solenoid directs the internal control slider against the spring force in the hydraulic section of the valve, thereby switching the oil pressure between the working chambers A and B. The working chamber that is decoupled from the oil pressure is connected to the return. In order to fix a timing position, the valve is held in the "central position" where it is almost entirely decoupled from all connections.

- 1 Solenoid
- 2 Control slider
- 3 Oil chamber supply
- 4 Return
- 5 Engine control unit
- 6 Connection to the crankshaft sensor
- 7 Connection to the camshaft sensor
- 8 Oil pump

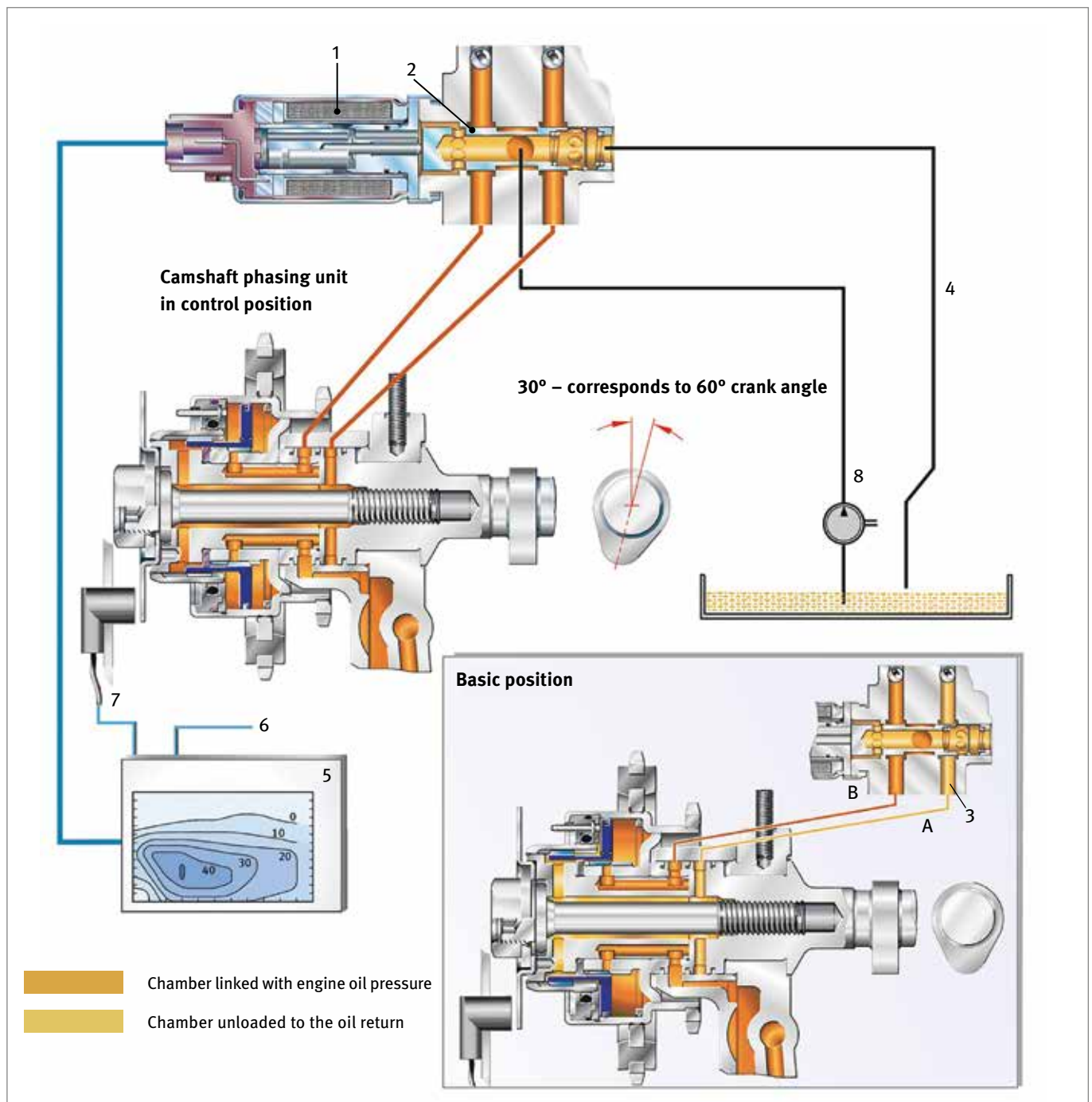

Fig. 61: Representation of control valve system

Recommendations for changing camshaft phasing units

Timing pin

Some camshaft phasing units have a timing pin. For correction installation, the pin must always be aligned with the corresponding bore in the camshaft. If this is not the case, the function is not available and the belt or the chain is not guided correctly.

Rotary shaft seal

When changing the camshaft phasing unit in the belt drive, it is recommended to also change the rotary shaft seal, which seals the connection point between the camshaft and cylinder head.



Fig. 62: Timing-Pin

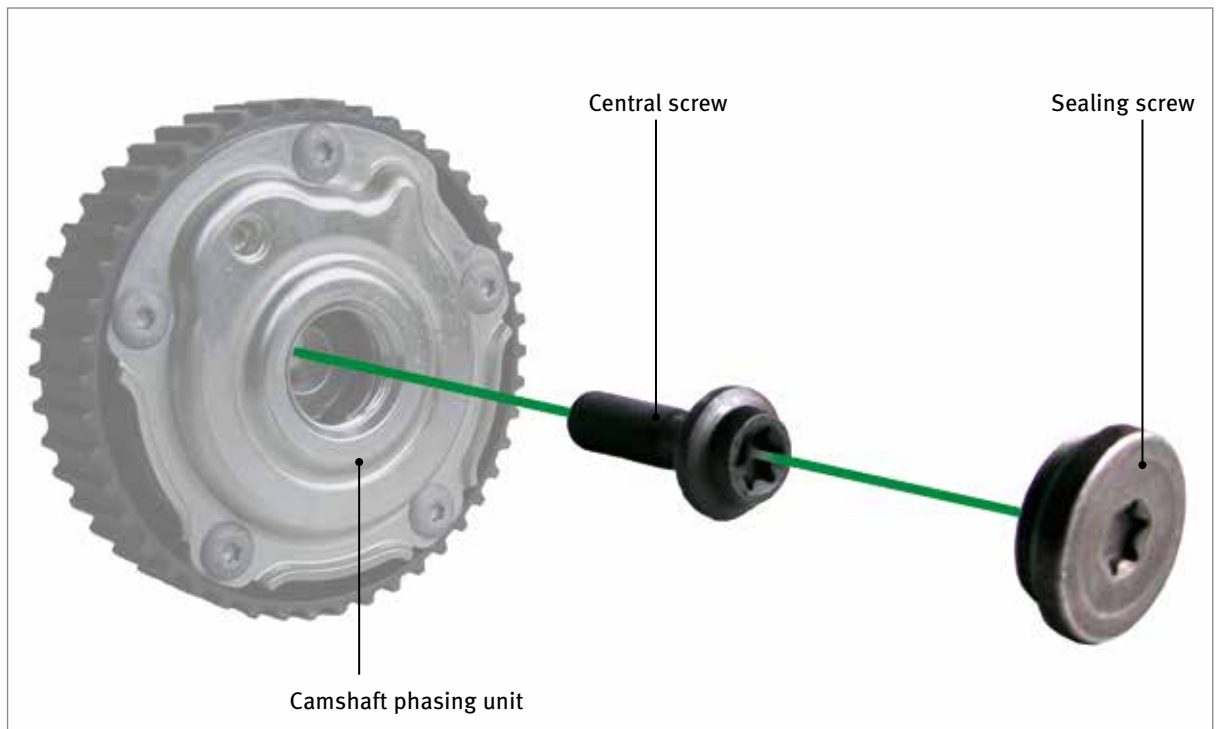

Fig. 63: Camshaft phasing unit, central screw, sealing screw

Central screw

If the central screw of the camshaft phasing unit becomes loose, it should always be replaced. The screw is plastically deformed by the compulsory tightening torque specified by the vehicle manufacturer. Reuse is therefore not recommended.

Sealing screw

It is recommended to also always replace the sealing screw as the sealing ring can be damaged when loosening.

5.6 UniAir

With the UniAir system, not just the stroke and the opening and closing time of the valves can be changed but also the opening duration and the number of openings. The UniAir system therefore enables the intake valves to be opened and closed multiple times during an intake phase, depending on the load condition and driver request, for each individual cylinder independently. This allows a more precise adjustment between the energy required, energy used and therefore increased energy efficiency; it makes UniAir the first fully variable and continuously variable valve timing.

For conventional, throttle valve-controlled gasoline engines, up to 10 % of the amount of fuel used is destroyed in the form of energy when measuring the correct air quantity in order to draw in the air against the resistance of the throttle flap in the cylinder. However, if a fully variable valve train is used, the throttle flap can be completely open or even omitted and the air quantity can

be drawn into the combustion chamber unhindered during the intake phase. Thanks to UniAir, the correct quantity of air for each operating state is regulated directly in the intake channels of the respective cylinder by controlling the timing or shape of the valve opening. This is a decisive factor when implementing the CO₂ emissions reduction.

Further benefits of the UniAir valve timing are lower fuel consumption, an increase in power rating and torque, as well as quicker engine response characteristics.

Note:

Further information about UniAir can be found in the INA brochure "UniAir System".

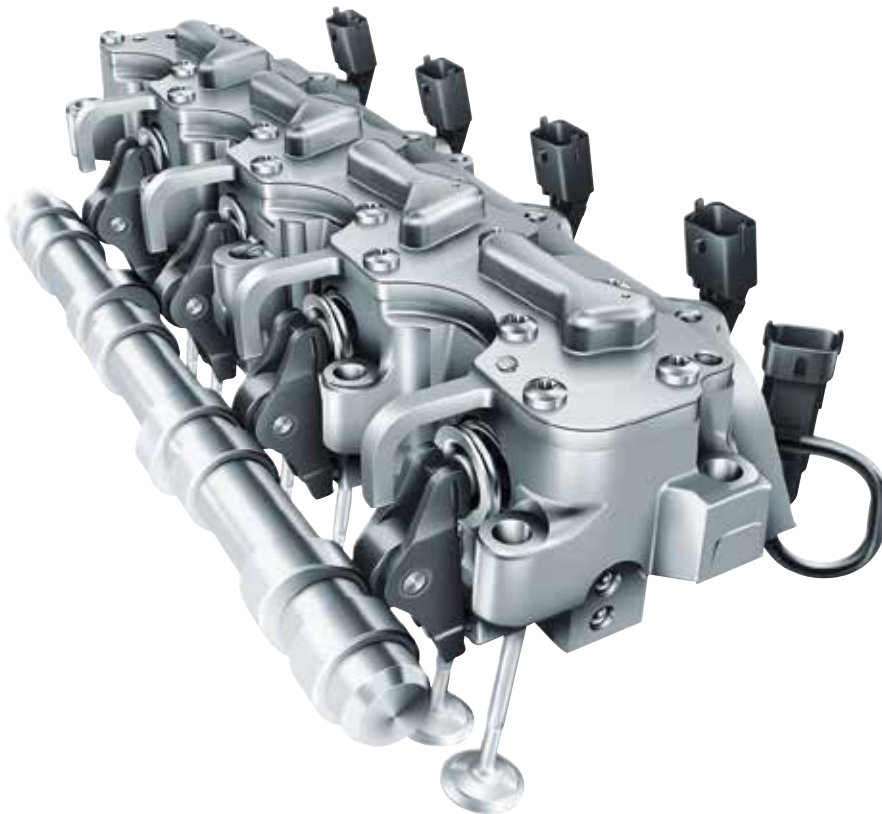

Fig. 64: UniAir

6 General Garage Instructions

Always replace elements as a set

If one or more hydraulic valve lash adjustment elements are damaged, the whole set of components must be replaced. If only individual elements are replaced, a uniform valve stroke is not guaranteed due to different amounts of leakage oil being released. This can cause valve closing errors, which then often lead to the valve seat burning through. Replacing entire sets therefore avoids multiple repairs and therefore higher costs for the customer.

New bucket tappet – new camshaft

When replacing bucket tappets, the camshaft must always be replaced too and vice versa. Due to the wear pattern on the bucket tappet base and the cam track, a combination of new and worn components will result in a short service life.

New rocker arm with insert element

Rocker arms with an insert element must not be dismantled (fit size)!

The oil feed bores or the oil return channels of the hydraulic insert element can be blocked by deposits. This means that the oil supply is no longer guaranteed and the rocker arm must be replaced along with the insert element.

Important:

The difference between the different hydraulic insert elements is mainly in the sink-down time. If an incorrect insert element is installed with a rocker arm, serious engine damage can occur!

Filling hydraulic elements

Hydraulic adjustment elements from INA are always filled with the prescribed amount of oil from the factory. They should therefore always be transported and stored in the transport position (see the arrow on the packaging) so that the oil does not escape. After installation of the hydraulic adjustment elements, the sink-down time must be allowed to elapse. This is between two and ten minutes at room temperature. Only then can the camshaft be turned and the engine started.

Engine oil

In principle, the engine oil approved by the vehicle manufacturer must always be used.

An important prerequisite for a precisely functioning valve train is also that the maintenance intervals for the engine oil prescribed by the vehicle manufacturer are adhered to. During these driving cycles, the performance/oil quality of the engine oil decreases.

In general, it is extremely important to ensure cleanliness when working on the valve train! Dirt particles can impair the function of the individual components or destroy them.

Recommendations for bleeding hydraulic valve lash adjustment elements in the engine

In certain circumstances, valve train noises can occur after the installation of hydraulic adjustment elements. Fast bleeding of the hydraulic elements is guaranteed if the following recommendations are adhered to:

- Run the engine for approx. four minutes at a speed of between 2000 rpm and 3000 rpm.
- Then keep the engine idling for approx. 30 seconds.
- If no noises can be heard coming from the valve train afterwards, the hydraulic element has been successfully bled. If there are still valve train noises perceptible, the first two steps must be repeated.

In 90 % of cases, valve train noise is eliminated after the first air bleeding cycle. In some individual cases, it can be necessary to repeat the above bleeding cycle five or six times. If noises can still be heard coming from the valve train after the fifth bleeding cycle, it is recommended that the relevant elements are replaced and further investigations conducted.

7 Failure Diagnosis and Damage Assessment

7.1. General Damage Assessment

For metallic mating components under mixed friction conditions, abrasive and adhesive wear processes occur. Both wear mechanisms and the fatigue wear, which leads to pitting on the surface, often cause a total failure of the sliding contact points. Wear can also be caused by various forms of corrosion.

- Abrasion generally means removal or chipping.
- Adhesion can be effective if the main and counter bodies are in direct contact.
- Pitting generally means material breakage.

Many parameters influence the wear:

- Material (material pairing, heat treatment, coating)
- Contact geometry (macro/micro geometry, dimensional accuracy, roughness, contact ratio)
- Load (forces, torques, Hertz pressure)
- Kinematic configuration (relative speed, hydrodynamic speed, unit pressure)
- Lubrication (viscosity, quantity, additives, contamination, aging)

Noises during the warm-up phase

Noises during the engine warm-up phase are not usually a reason for complaint. When the engine is switched off some valves can be in the open position and stress the hydraulic lash adjustment element through the valve springs. This means that oil is pressed out of the high-pressure chamber and gradually added during the warm-up phase.

The air cushion available in the hydraulic element in this state can be compressed and causes these temporary rattling noises.

Noises when the engine is warm

Noises with a warm engine are frequently due to insufficient oil supply. Reasons for this can be:

- Hydraulic piston sticking due to contaminated oil
- Oil foaming caused by the engine oil level being too high or too low
- Leakage on the intake side of the oil pump
- Oil pressure too low as a consequence of leaks in the oil lines or bearing wear

Noises due to "inflation"

Sources of this fault can be:

- Malfunctioning, fatigued or incorrect valve springs (incorrect assignment of parts)
- Malfunctioning valve guides or valve shafts
- Over-revving of the engine
- Incorrect oil quality

Cause:

The contact surfaces of the valve train running together lift up, which leads to a disproportionate piston stroke. As a consequence, not enough oil can be displaced within the short time span whilst loading the hydraulic element.

Result:

The valve does not close completely, which can lead to a loss in power and also burning through of the valve. A valve touching the piston base causes serious engine damage as a further consequence.

Due to the extremely tight tolerances, the adjustment elements react very sensitively to contamination in the engine oil. Irrespective of the increased wear of the moving parts, dirt particles in the hydraulic valve lash adjustment system are noticeable due to rattling noises.

7.2 Residual Dirt

ALUMINUM RESIDUES AFTER CYLINDER HEAD PROCESSING (E.G. SURFACE GRINDING)



Large quantities of residual dirt particles are often discovered when returned defective parts are examined. These residual dirt particles, such as particles of aluminum, are formed when the cylinder head is machined.

COMBUSTION RESIDUES FROM A DIESEL ENGINE

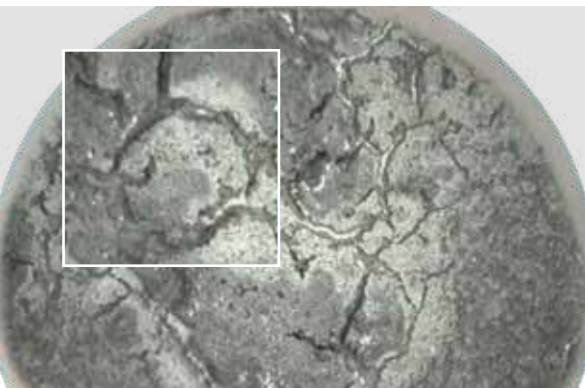

Fibers from cleaning rags and cloths, as well as combustion residue from diesel engines, are also frequently found in the engine oil.

7.3 Failure Diagnosis of Valve Train Components

Important

Hydraulic components that are believed to be faulty must be examined in line with the relevant instructions provided by the manufacturer. The methodology detailed here is generally suitable for all component types.

Visual inspection

Hydraulic components showing external damage in the form of scoring, scratches or scuffing must always be replaced. The mating surface in the valve train must also be examined.

On hydraulic bucket tappets, particular attention must be paid to examining the tappet crown. This contact surface is the point in the engine that is subjected to the most pressure.

Manual inspection

A simple yet effective means of manually checking a hydraulic valve lash adjustment element under garage conditions is to check the compression characteristics of the component.

A filled element should not compress quickly when manual pressure is applied. This test must be carried out with care, however, otherwise the oil will be pressed out of the leakage oil gap.

If the filled element compresses quickly without excessive pressure being applied, the component must always be replaced. It is not possible to check the functionality of hydraulic elements more precisely without using complex testing and inspection equipment. Inspecting components using complex equipment allows various parameters to be determined, such as the sink-down value; this information can only be gathered at the manufacturer's premises.

Damage assessment of a bucket tappet

WEAR ON THE BASE OF THE BUCKET TAPPET



Normal wear

- Normal operational profile of a bucket tappet.
- The circular marks all round are due to the rotation of the ram and are not cause for complaint.

Action

- No action required.



Increased wear

- Heavy traces of wear on the base of the bucket tappet.
- With this type of operational profile, high material abrasion due to wear on the base of the bucket tappet can be assumed.

Action

- The bucket tappet and the camshaft must be replaced.



Heavy wear

- Adhesive-abrasive wear through to a total failure.

Action

- The bucket tappet must be replaced. An intensive check of the camshaft position (misalignment of the camshaft due to bearing wear) is also required.

WEAR ON THE FINGER FOLLOWER AND PIVOT ELEMENT



Bucket tappet



Guide bore

Cause

- Proportion of residual dirt in the engine oil too high.

Result

- Bucket tappet sticks in the mounting hole.

Action

- Clean the engine (rinse).
- Ensure cleanliness when installing the new bucket tappet.

Damage assessment for a finger follower

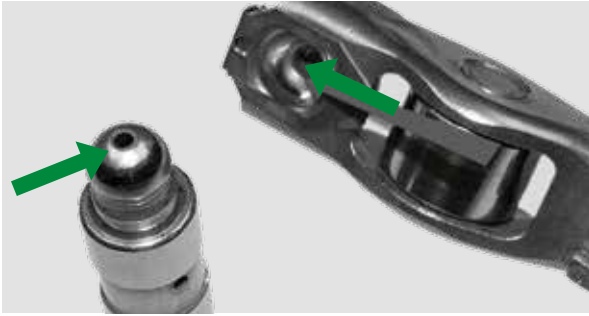

WEAR ON THE FINGER FOLLOWER AND PIVOT ELEMENT



Note:

Viewing direction of the following four figures.

Normal wear

- Polished smoothing mark in the contact area with the finger follower cap. (bottom fig.)
- Normal signs of wear across the rating life.
- Polished smoothing mark in the contact area with the ball head. (top fig.)

Cause

- Lack of oil – e.g. due to blocked oil channels.

Action

- No action required – the bearing area is OK.

Increased wear

- Heavy abrasive wear on the ball head in a critical magnitude; the wear led to deformation of the ball head.

- Heavy abrasive wear on the cap in a critical magnitude; the wear led to deformation of the cap.

Action

- The hydraulic pivot element and the corresponding finger follower must be replaced.

Damage assessment for a finger follower



WEAR ON THE VALVE CONTACT FACE OF THE FINGER FOLLOWER



Damage assessment for a cam roller

WEAR ON THE OUTER RING OF THE CAM ROLLER

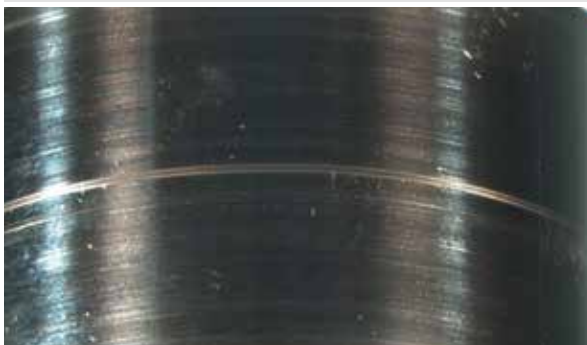

Note:
Viewing direction of the following four figures

- Normal wear**
- Light smoothing marks on the valve contact face due to the relative movement between finger follower and valve.
 - Normal signs of wear across the rating life.

Action

- No action required – the bearing area is OK.

- Heavy wear**
- Heavy abrasive wear of the valve contact face.
 - Clearly pronounced edges around the contact area indicate a wear depth in the range of a few tenths.
 - There is the risk of arm breakage if operation is continued.

Action

- Replacement of the hydraulic pivot element and corresponding finger follower and check of the valve shaft.

- Normal wear**
- The outside diameter of the cam roller does not show any visible wear. The marks all round are normal and come from small foreign particles between the cam roller and cam.
 - Normal signs of wear across the rating life.

Action

- No action required – the bearing area is OK.

- Heavy wear**
- The outside diameter of the cam roller shows a considerably changed geometry.

Action

- Replacement of the hydraulic pivot element and corresponding finger follower.
- Check of the corresponding camshaft position for misalignment due to bearing wear.

Damage assessment for a roller-type finger follower

WEAR ON THE ROLLER BOLT OF THE FINGER FOLLOWER

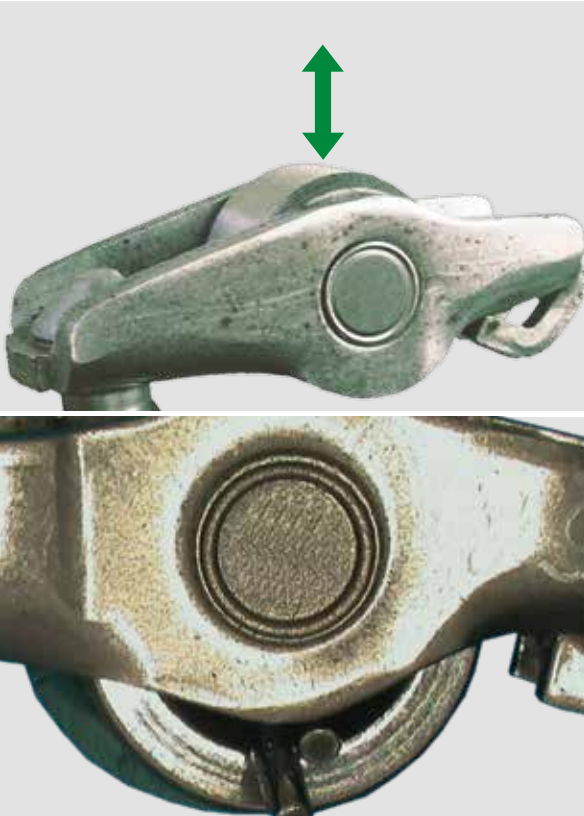

Check of the radial clearance of the cam roller

The radial clearance can be determined relatively easily by moving the cam roller in a radial direction upwards and downwards.

With a radial clearance in the range of several tenths, the load zone of the roller bolt is worn and the finger follower must be replaced.

Heavy wear

- The needles of the cam roller are no longer fixed and can lead to a total failure of the roller-type finger follower.

Action

- The hydraulic pivot element and the corresponding roller-type finger follower must be replaced.

NON-RETURN VALVE OF THE PIVOT ELEMENT



Cause

- Foreign particles which were rinsed as contamination into the valve lash compensation element via the engine oil

Result

- The non-return valve no longer works correctly.

Attention:

The warranty obligation from the manufacturer is void if parts are dismantled by the garage within this time period. Due to the required precision of the hydraulic pivot element, dismantled parts may no longer be installed as then the function can no longer be guaranteed.

Damage assessment for camshaft phasing

RATTLING NOISES IN THE AREA OF THE PHASING UNIT



Noises within the first 1-3 seconds after starting the engine

Cause

- The locking clearance is too large.

Action

- The phasing unit must be replaced.

Noises in different speed ranges

Cause

- Bearing play too large due to wear.

Action

- The phasing unit must be replaced.

Control valve for camshaft phasing

CONTROL VALVE NOT WORKING



Cause

- Due to dirt particles in the engine oil, the piston in the control valve cannot work correctly; the piston jams.
- Bad or corroded plug connection to the control valve.

Action

- The control valve must be replaced.
- The plug connection must be checked or repaired.

Note:

If the control valve piston does not reach the required end positions, the engine control unit issues a corresponding error message ("Desired angle not reached").

More garage knowledge:
www.rexpert.com