

Service.

Engine
code
letters

DJ	MV	SR	SS											

Workshop Manual Volkswagen Transporter 1980 ▶

2.1 ltr. Fuel Injection Engine, Mechanics

ProCarManuals.com

Edition December 1992



Service Department

Content

00 Technical data	Page
Technical Data	00- 1
– Engine number	00- 1
– Engine specifications	00- 2
10 Removing and installing engine	Page
Removing and installing engine	10- 1
– Instructions for removal	10- 1
– Additional work associated with type specific equipment	10- 3
– Attaching engine to repair stand	10- 4
– Instructions for installation	10- 5
– Tightening torques	10- 6
13 Crankshaft group	Page
Dismantling and assembling engine	13- 1
– Removing and installing three groove pulley	13-16
– Checking and adjusting crankshaft axial play	13-18
Dismantling and assembling pistons and cylinder	13-20
– Piston allocation to cylinder head	13-28
– Piston and cylinder dimensions	13-28
– Installing pistons	13-29
– Installing cylinder	13-30
Dismantling and assembling crankcase	13-31
Dismantling and assembling crankshaft	13-38
– Crankshaft dimensions	13-49
15 Cylinder head, Valve gear	Page
Removing and installing cylinder head	15- 1
– Repair instructions for hydraulic setting valve clearance	15- 5
– Installing hydraulic tappets	15- 6
– Bleeding hydraulic tappets	15- 7
– Installing cylinder head	15- 8
– Basic settings for hydraulic valve gear	15- 9
– Removing and installing push rod guide tubes	15-10
– Checking compression pressures	15-11
Servicing cylinder head	15-13
– Reworking valve seats	15-16
– Checking valve guides	15-18
17 Lubrication system	Page
Removing and installing parts of lubrication system	17- 1
– Checking oil pressure and oil pressure switch	17- 7
19 Cooling system	Page
Removing and installing parts of cooling system	19- 1
– Draining and refilling system with coolant	19-12

20 Fuel system	Page
Removing and installing parts of the fuel system	20- 1
- Vehicles with rear wheel drive	20- 2
- Synchro	20- 6
- Safety precautions	20- 9
- Rules for cleanliness	20-10
- Removing fuel tank	20-11
- Removing and installing fuel gauge sender	20-15
- Checking fuel system for leaks (vehicles with rear drive)	20-16
- Checking fuel pump	20-17
Servicing throttle control	20-21
- Throttle control on vehicles with manual gearbox	20-23
- Throttle control on vehicles with automatic gearbox	20-23
- Adjusting throttle control (vehicles with automatic gearbox)	20-25
26 Exhaust system	Page
Removing and installing parts of the exhaust system	26- 1

Technical Data

Engine number

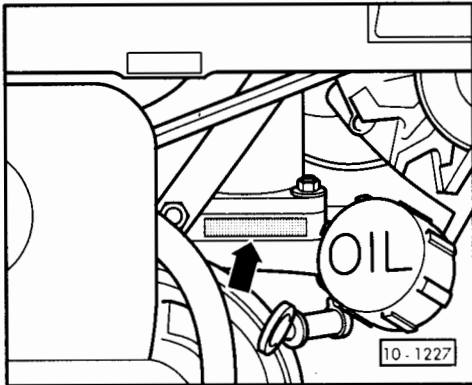

- ◀ The engine number (code letters as well as serial number) are stamped on the right-hand side of the engine block on the flange under the oil vent.

Engine specifications

Engine code letters	DJ	MV	SR ¹⁾	SS ²⁾
Manufacture	03.85 ▶	08.85 ▶	10.86 ▶	08.89 ▶
Swept volume	1 2.1	2.1	2.1	2.1
Output	kW at RPM 82/4800	70/4800	64/4000	68/4500
Torque	Nm at RPM 174/2800	160/2800	160/2800	154/2800
Bore	mm Ø 94	94	94	94
Stroke	mm 76	76	76	76
Compression ratio	10.5	9.0	9.0	9.0
RON	min. 98	91 lead-free	91 lead-free	91 lead-free
Fuel injection	Digijet	Digifant	Digifant	Digifant
Ignition system	TSZ-H	Digifant	Digifant	Digifant
Knock control	-	-	-	-
Self-diagnosis	-	-	-	-
Lambda control	-	x	x	x
Catalyst	-	x	x	x
Supercharging	-	-	-	-

¹⁾ For Switzerland

²⁾ For rear drive – manual gearbox according to EEC Standard

Removing and installing the engine

Instructions for removal

The motor is separated from the gearbox and removed downwards.

All cable ties which are loosened or cut for removal of the engine must be refitted at the same place when installing the engine.

- To prevent short circuiting, switch off the engine and disconnect the earthing strap from the battery.

Note:

If applicable, determine the radio anti-theft code before disconnecting the earthing strap from the battery.

Attention!

Only remove the lower securing nuts between engine and gearbox after the gearbox is supported on the VW 785/1 B support and the engine on the V.A.G 1383A lifting device.

10-1

Before separating engine from gearbox

- ◀ - Loosen the gearbox mounting bolt -arrow-.

Additional work associated with type specific vehicles ⇒ Page 10-3.

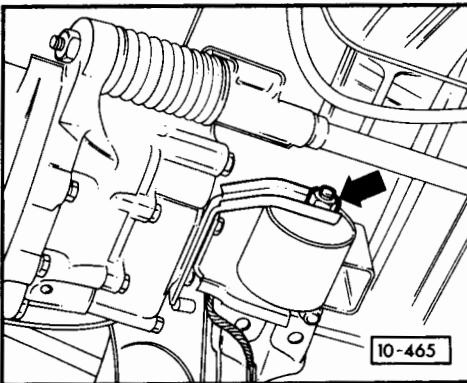

- ◀ - Install the VW 785/1B so that the distance between the plate and the gearbox housing is approx. 120 mm.

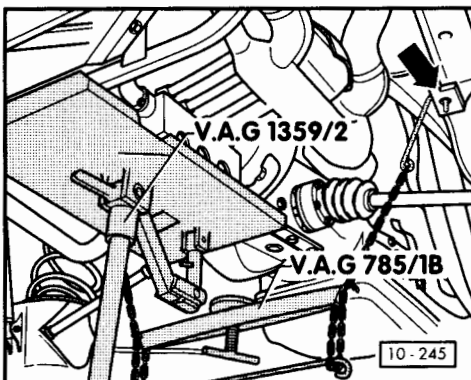

10-2

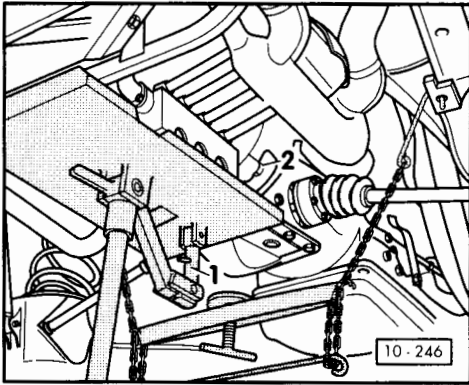

Separating engine from gearbox and removing engine

- ◀ – Lower engine and gearbox with V.A.G. 1359/2 or V.A.G. 1383A until the engine rests on support VW 785/1 B. During lowering adjust angle of inclination with adjusting screw –1–.
- Remove nuts from lower engine securing bolts –2–.
- Withdraw engine from gearbox housing and take out downwards.

Additional work associated with type specific equipment

Vehicles with automatic gearbox

- ◀ – Remove accelerator rod –2–.

Vehicles with power steering

- Remove power assisted steering vane pump and place on side of engine compartment with pipes still connected.

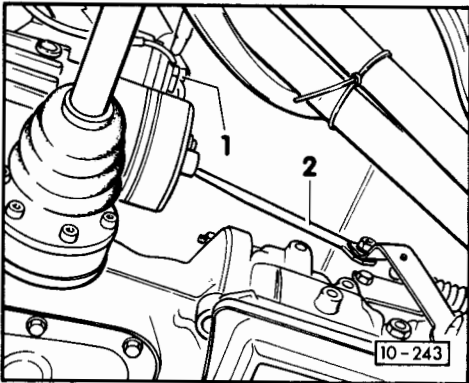

10-3

Vehicles with air conditioner

- Remove air conditioner compressor and place on side of engine compartment with pipes still connected.

Synchro

- Remove rear protective plate (underneath engine and gearbox).
- ◀ – Unscrew front gearbox mounting bolts –arrow– 3 turns.

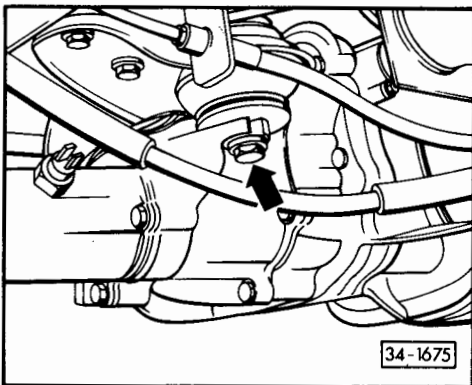

Attaching engine to repair stand

- ◀ – In order to carry out the necessary work the engine should be attached to a repair stand with holding device VW 307 a.

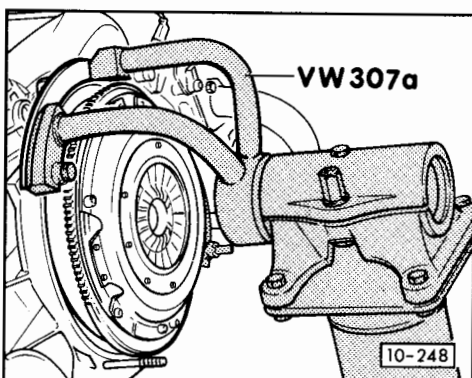

10-4

Instructions for installation

- Check clutch release bearing for wear and renew if necessary.
- Lightly lubricate clutch release bearing and input shaft splines with G 000 100. (Do not lubricate the release bearing guide sleeve).

Synchro

- Clean connecting surfaces on engine and gearbox and lightly coat engine connecting surface with silicon adhesive sealant AMV 176 005 05.

Continuation applicable to all vehicles

- Adjusting throttle cable/accelerator linkage
⇒ Page 20–21, Servicing throttle control.
- Tensioning V-belt ⇒ Page 13–1, Dismantling and assembling engine.
- Filling with coolant ⇒ Page 19–12, Draining and filling with coolant.
- Electrical connections and cable run:
⇒ circuit diagrams, Fault finding electric circuits and installation locations.
- Adjusting ignition timing:
⇒ Repair Group 28.

10–5

- Adjusting idling speed and CO content:
⇒ Repair Group 24, Adjusting idling speed.

Tightening torques:

Engine to gearbox	30 Nm
Engine bearer to body	25 Nm
Gearbox mountings	30 Nm
Torque converter on drive plate	20 Nm

Note:

Renew self-locking nuts on engine bearer attachments.

10–6

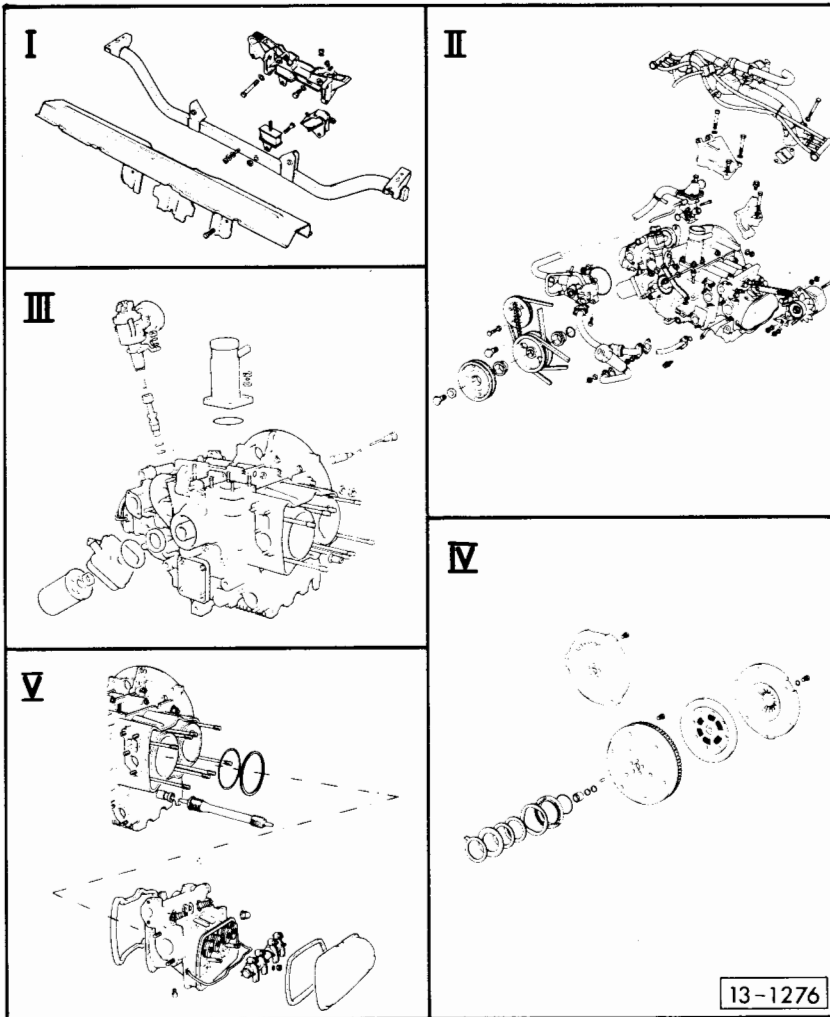

Dismantling and assembling engine

Removing and installing parts of the exhaust system ⇒ Page 26-1.

- Part I ⇒ Page 13-2
- Part II ⇒ Page 13-3
- Part III ⇒ Page 13-6
- Part IV ⇒ Page 13-9
- Part V ⇒ Page 15-1

Notes:

- Secure hoses with hose clips so that, with the engine installed, spring type clips can be removed with pliers.
- If, during engine repair work, large amounts of swarf and metal particles are noted in the engine oil caused by, for instance, seizing of main and connecting rod bearings, the oil passages must be thoroughly cleaned and the oil cooler renewed so as to avoid subsequent damage to the engine.

13-1

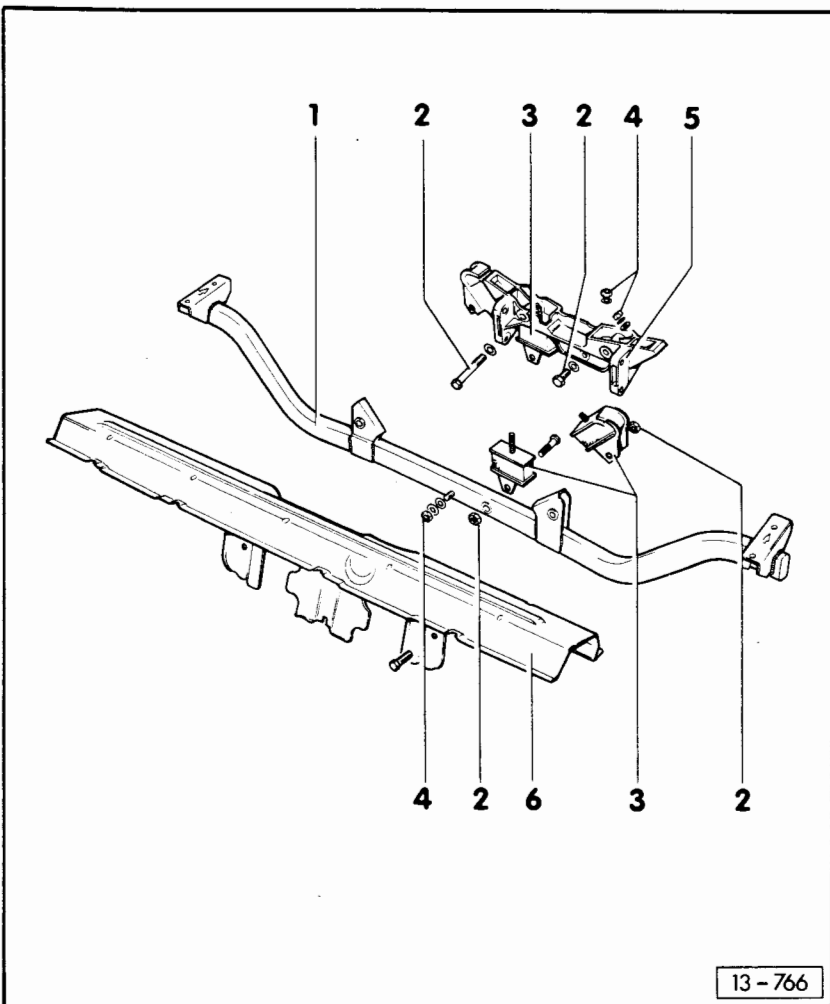

Part I

Note:

Engine bearers and engine bearer brackets can be removed and installed with the engine in situ. When carrying out this work, support the engine with VW 785/1B or V.A.G 1383A.

- 1 – Engine bearer
 - Note installation position:
Arrows points in direction of travel
- 2 – 45 Nm
- 3 – Bonded rubber bearer
- 4 – 20 Nm
- 5 – Bearer bracket
- 6 – Cover plate

13-2

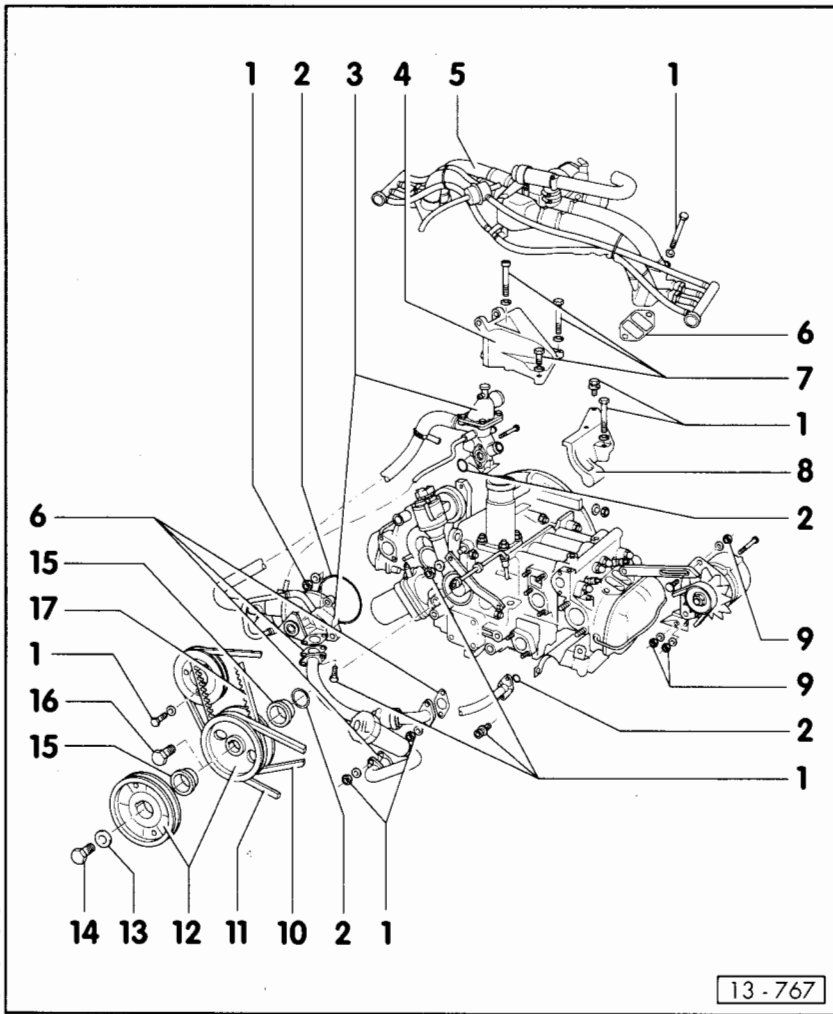

Part II

- 1 – 20 Nm
- 2 – O-ring
 - Renew
- 3 – **Coolant pump and thermostat housing**
 - Remove complete with pipes
 - Servicing ⇒ Page 19-1, removing and installing parts of cooling system
- 4 – **Air conditioner compressor bracket**
- 5 – **Fuel system**
 - Remove complete
 - Servicing: ⇒ Repair Group 24; Servicing fuel injection system
- 6 – **Gasket**
 - Renew
- 7 – 35 Nm

13-3

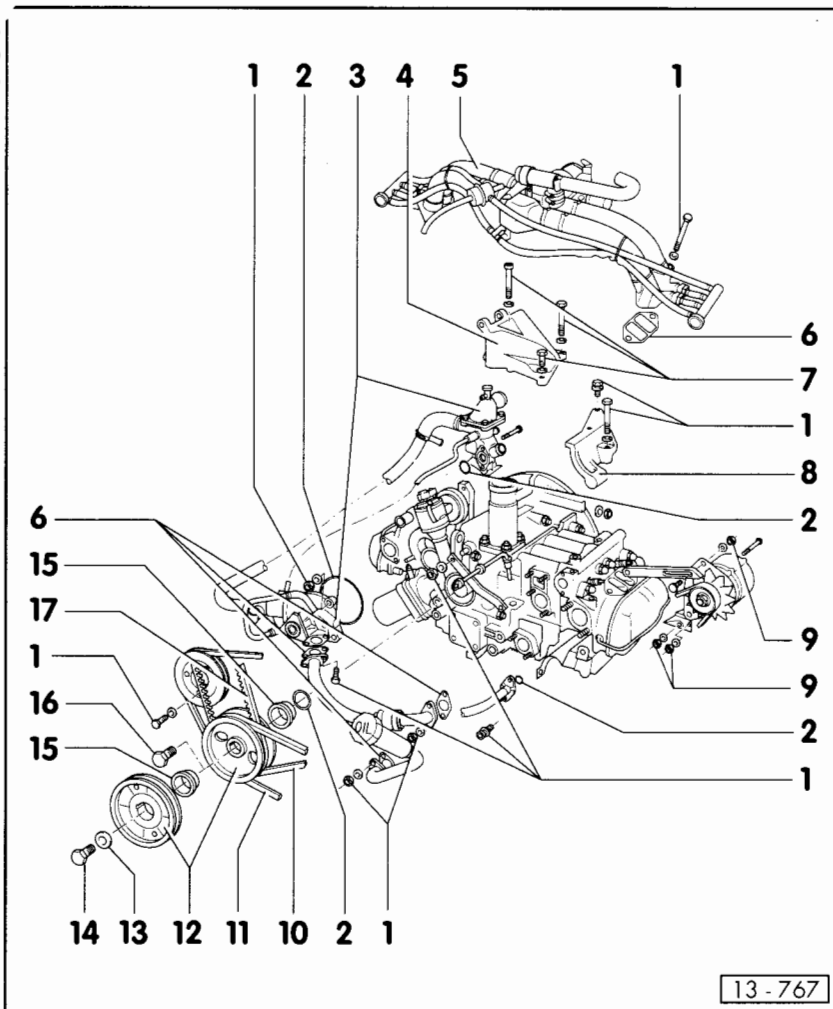

- 8 – **Vane pump bracket**
 - Only with power assisted steering)
- 9 – 30 Nm
- 10 – **Coolant pump/Generator V-belt**
 - Check tension by pressing down with thumb:

New V-belt:	10 mm
Used V-belt:	15 mm
- 11 – **Vane pump V-belt**
 - Only with power assisted steering
 - Check tension by pressing down with thumb, deflection 10...15 mm
- 12 – **V-belt pulley**
 - Replacement part has only TDC marking
 - Provide ignition timing notches:
 - 5° before TDC = 7.5 mm before TDC marking (right side),
 - 10° before TDC = 15 mm before TDC marking (right side)
 - Removing and installing three groove pulley ⇒ Page 13-16

13-4

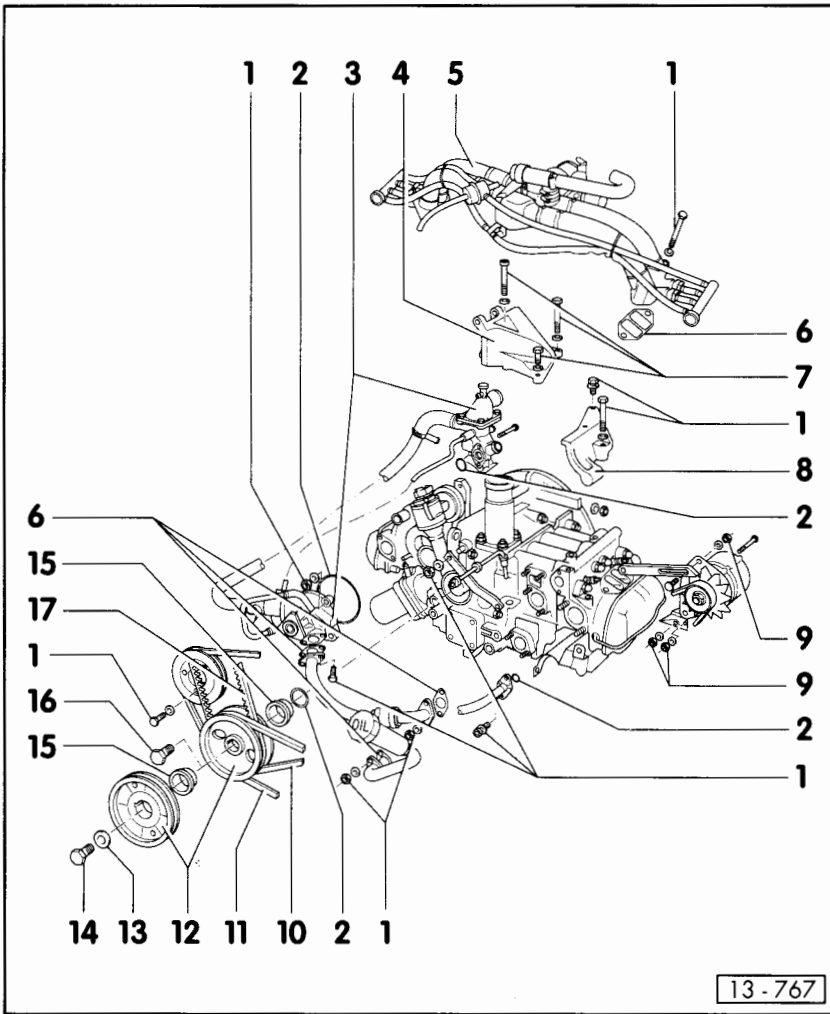

- 13 – Washer**
 - Only with single V-belt pulley
- 14 – 60 Nm**
 - When loosening or tightening lock the flywheel or carrier plate through the hole in the crankcase
- 15 – Thrust ring for V-belt pulley**
 - Only with synchro
 - Lever off with 2 screwdrivers
 - Press new thrust ring on until flush
- 16 – 315 Nm or 350 Nm**
 - Removing and installing three groove pulley ⇒ Page 13-16
- 17 – Air conditioner compressor V-belt**
 - Check tension by pressing down with thumb, deflection 10...15 mm
 - Tensioning ⇒ Page 13-12, Fig. 1

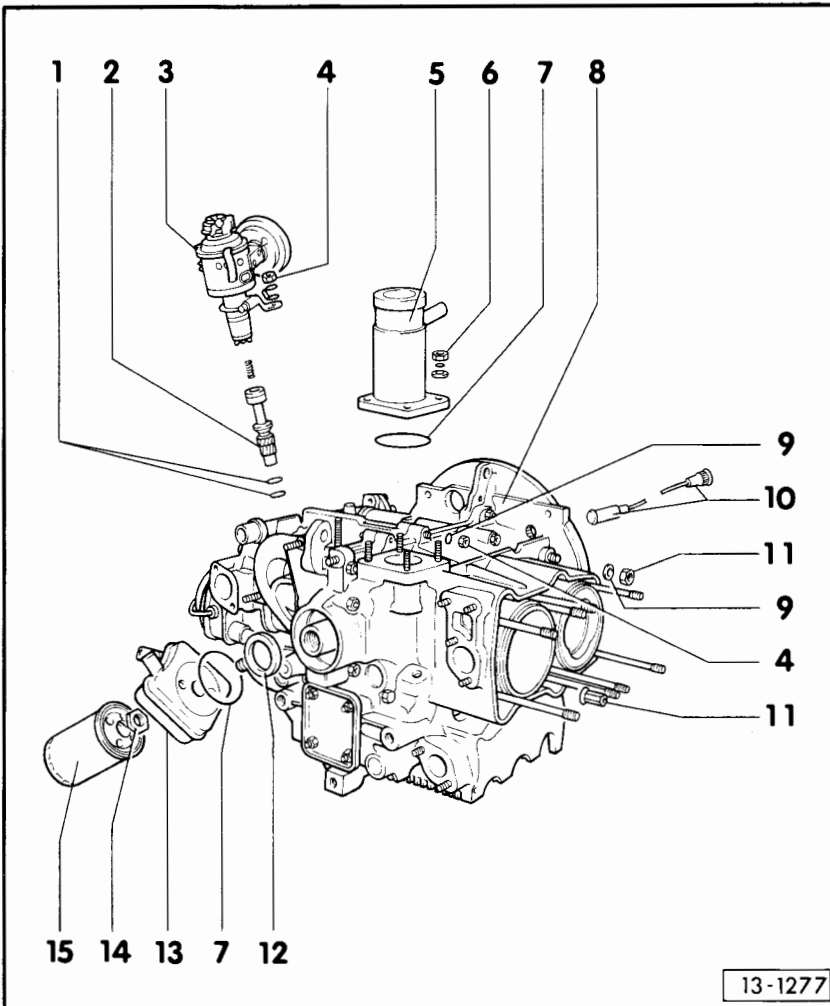

Part III

Removing and installing cylinder head
⇒ Page 15-1

- 1 – Thrust washers**
 - Install and align with screwdriver
- 2 – Distributor drive shaft**
 - Removing and installing
⇒ Page 13-12, Fig. 2
- 3 – Distributor**
 - Installing ⇒ Page 13-13, Fig. 3
- 4 – 20 Nm**
- 5 – Crankcase vent**
- 6 – 8 Nm**
- 7 – O-ring**
 - Renew

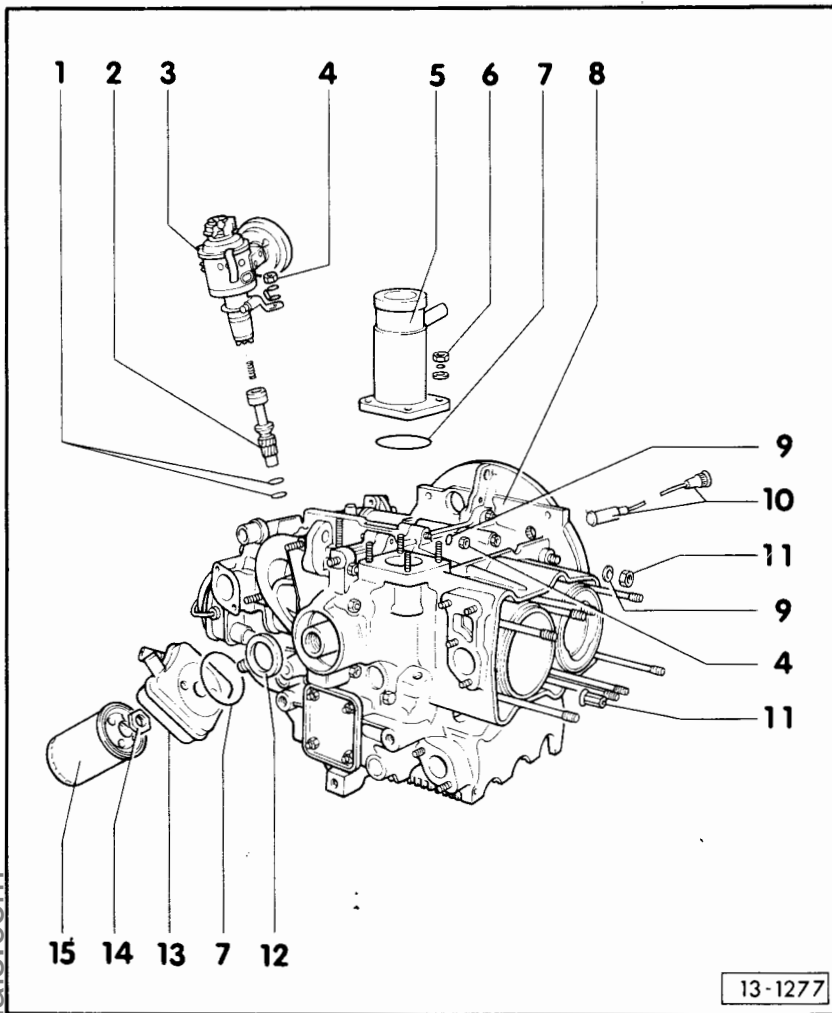

- 8 – Crankcase**
 • Assembling ⇒ Page 13–13, Fig. 4

- 9 – Washer**
 • Clean and degrease
 • Coat both sides with
 AMV 188 000 02

- 10 – Dead centre point sender**
 • TDC sender
 • Installing ⇒ Page 13–14, Fig. 5

- 11 – Nut, 45 Nm**
 • Coat cleaned and degreased contact face of flanged nut (or washer for nut) with AMV 188 001 02

- 12 – Sealing ring**
 • Lever out with assembly lever
 • Installing ⇒ Page 13–14, Fig. 6

13–7

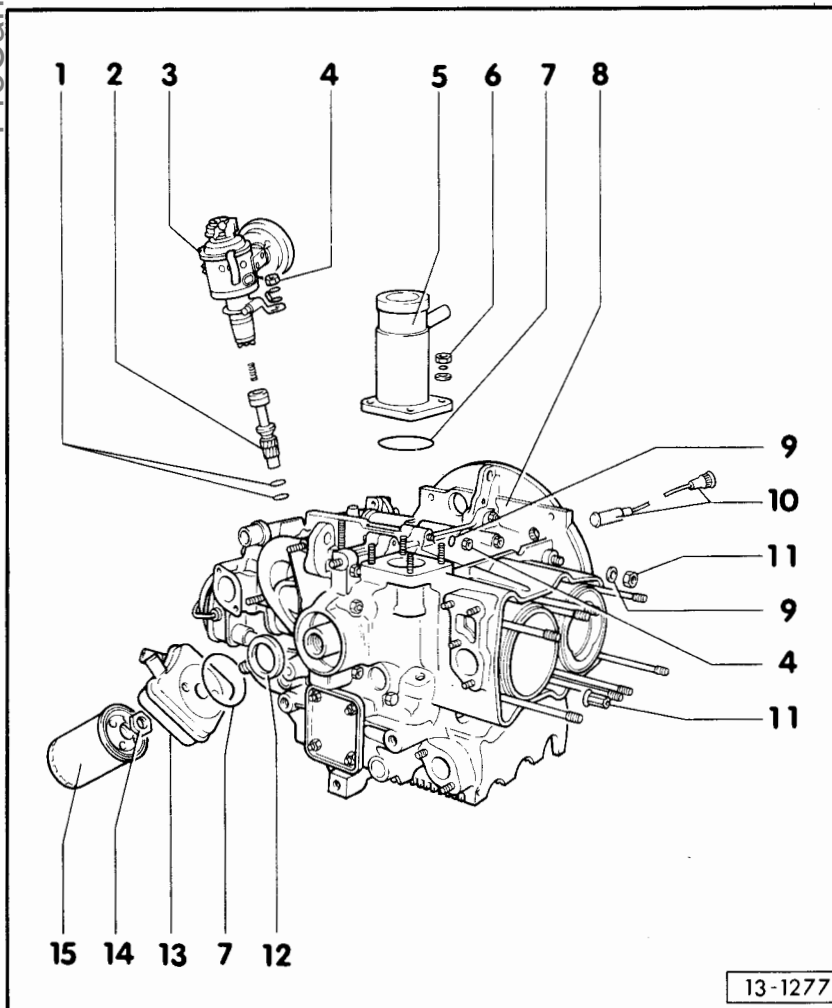

- 13 – Oil cooler**
 • Coat contact surfaces to flange outside of sealing ring with AMV 188 101 02
 • Ensure clearance to surrounding components
 • If swarf, caused by seizure of main and connecting rod bearings, are noted in engine oil, renew oil cooler

- 14 – 25 Nm**

- 15 – Oil filter**
 • Loosen with strap wrench
 • Tighten by hand
 • Note installation instructions on filter

13–8

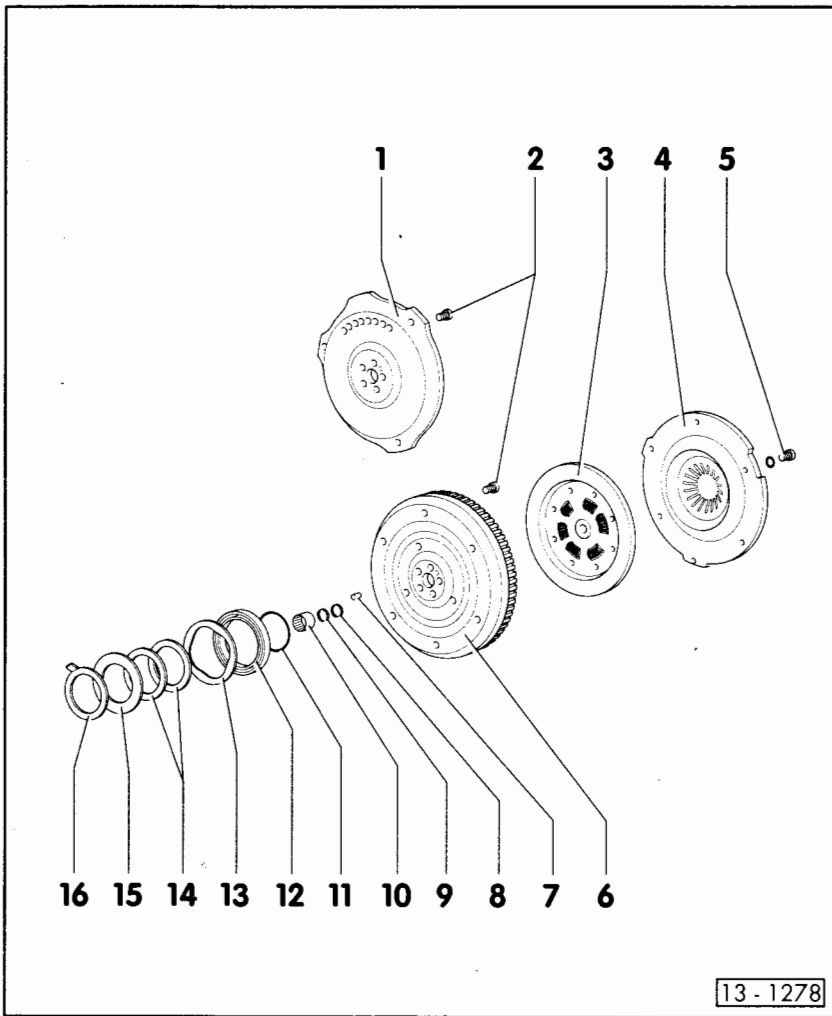

Part IV

Servicing the clutch ⇒ 5-speed manual gearbox 094; Repair Group 30, Servicing clutch

- 1 – Carrier plate**
 - Automatic gearbox
 - Removing and installing ⇒ Page 13–15, Fig. 7
- 2 – 60 Nm + further 1/4 turn (90°)**
- 3 – Clutch plate**
 - Install with 10-213
- 4 – Pressure plate**
 - Mark installation position
- 5 – 20 Nm**

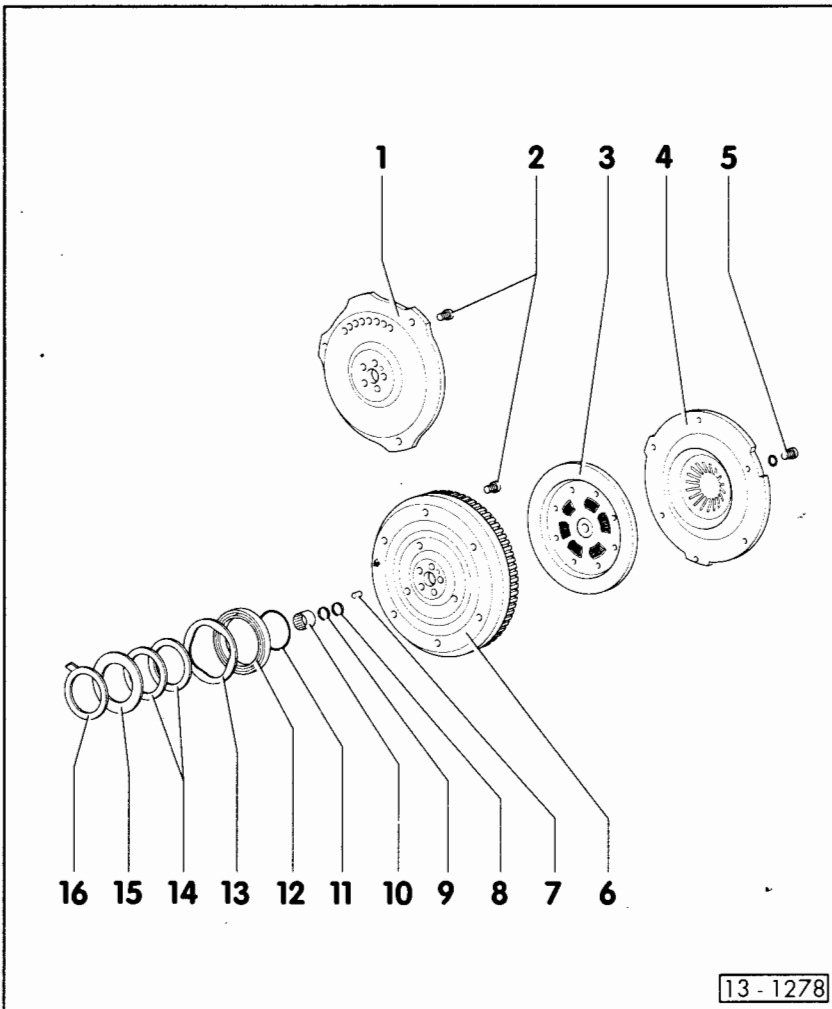

- 6 – Flywheel**
 - When removing or installing lock with VW 215c
 - Checking and adjusting crankshaft axial clearance ⇒ Page 13–18
- 7 – Dowel pin**
- 8 – Spacer ring**
- 9 – Felt ring**
- 10 – Needle roller bearing**
 - In crankshaft
 - Only with manual gearbox
 - Removing ⇒ Page 13–46, Fig. 9
 - Installing ⇒ Page 13–46, Fig. 10
 - Lubricate with G 000 100
- 11 – O-ring**
 - In flywheel
 - Renew

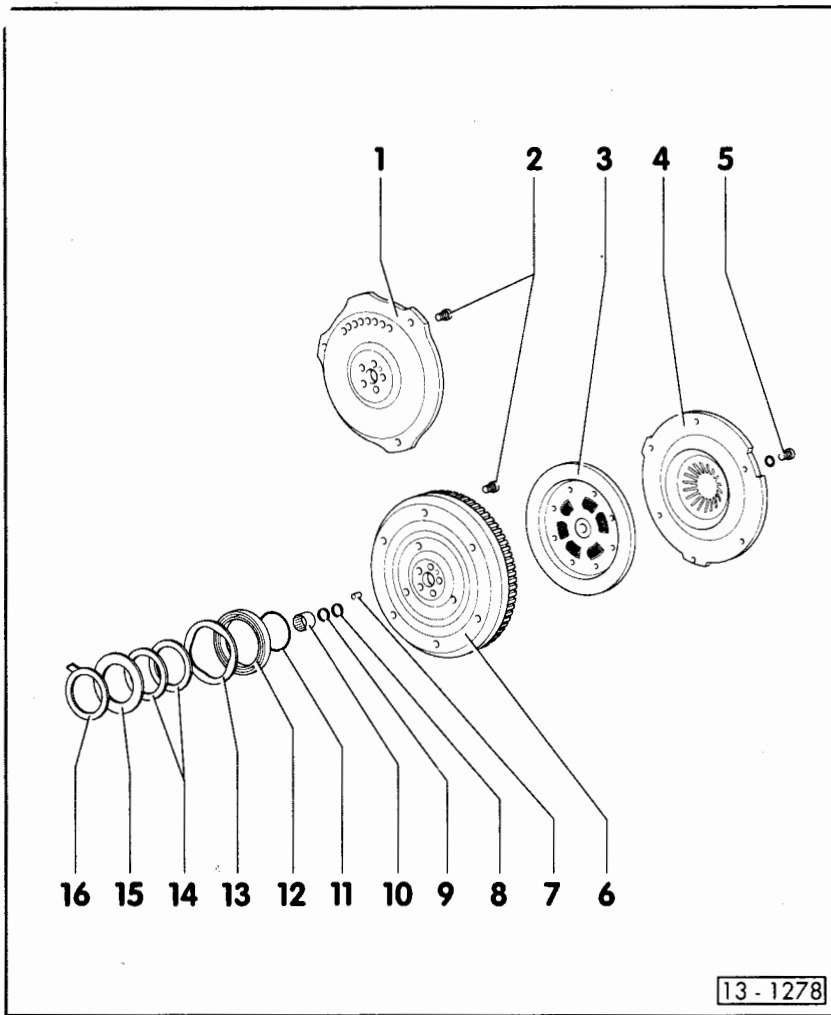

- 12 – Sealing ring**
 - Lever out with screwdriver
 - Installing ⇒ Page 13–15, Fig. 8
- 13 – Retaining plate**
 - Ø 75 mm
- 14 – Shims**
 - Determine thickness by adjusting axial play ⇒ Page 13–18. Check crankshaft axial play and adjust as necessary
- 15 – Shim**
 - Ø 81 mm
- 16 – Thrust washer**
 - Retaining lug points towards crankshaft bearing

13–11

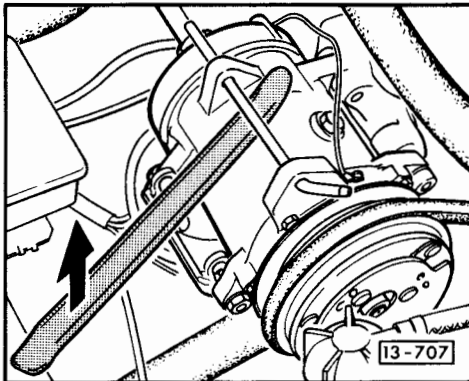

◀ Fig. 1 Tensioning air conditioner compressor V-belt

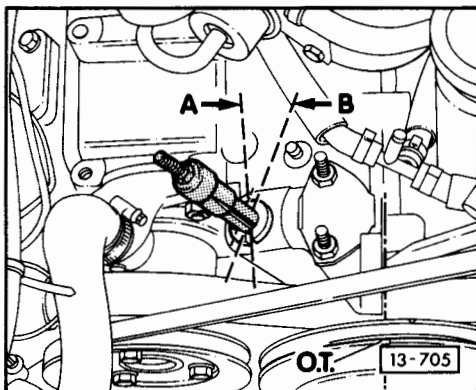

◀ Fig. 2 Removing and installing distributor drive shaft

- Position crankshaft at TDC on No. 1 cylinder.
- Remove and install with standard 14.5...18.5 mm Ø internal extractor e.g. Kukko 21/2.

Installation position:
 Position –arrow A–
 Installed –arrow B–.

The small segment points towards coolant pump.

13–12

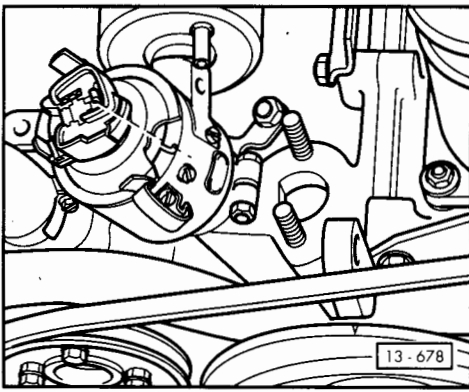

◀ Fig. 3 Installing the distributor

- Set crankshaft to ignition timing notch for No. 1 cylinder.
- Turn rotor arm until it is pointing towards to No. 1 cylinder mark on distributor housing.

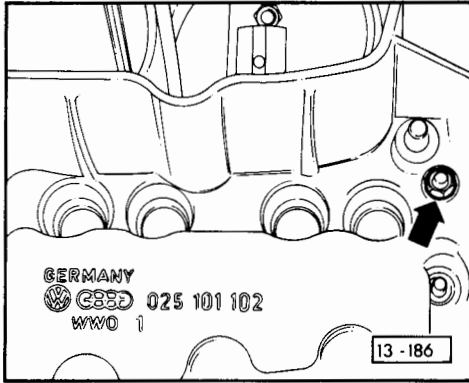

◀ Fig. 4 Assembling crankcase halves

- Coat both faces of washers with AMV 188 001 02.
- First tighten M8 hex. head nut –arrow–.
- Then tighten M10 hex. head nuts.
- Then tighten remaining M8 nuts.

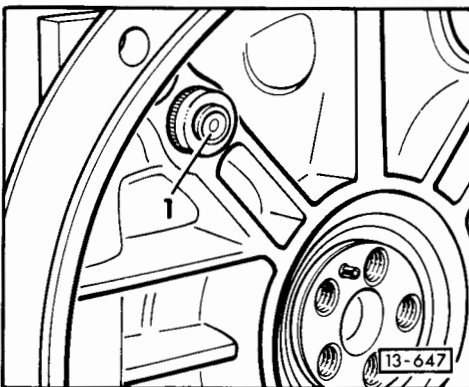

◀ Fig. 5 Installing dead centre sender (TDC sender).

- Drive sender into housing up to shoulder with old piston pin and plastic hammer.
- Do not damage inner ring –1– of sender.

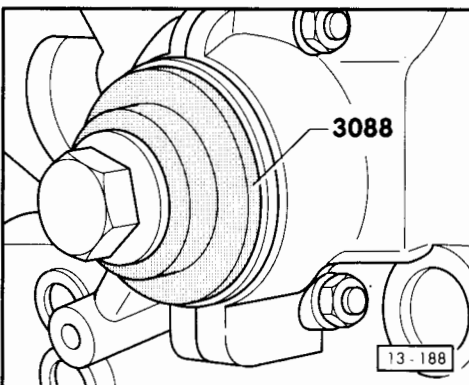

◀ Fig. 6 Installing sealing ring

- Lightly oil sealing lip of new sealing ring.
- Install sealing ring with 3088 (3162 with synchro) and bolt for V-belt pulley without washer.
- Then tighten bolt with washer (min. thickness 3 mm) up to shoulder.

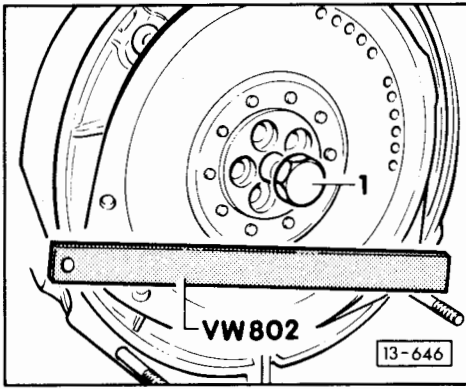

◀ Fig. 7 Removing drive plate

- Use M18 x 1.5 x 60 bolt (threaded portion at least 45 mm) –1– to pull off.

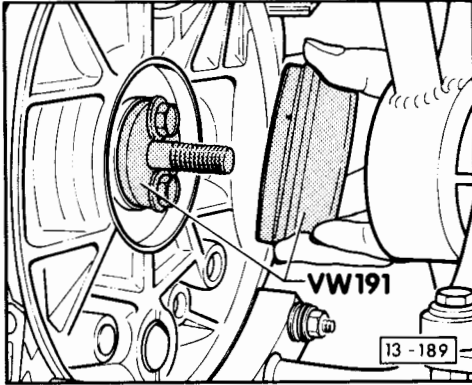

◀ Fig. 8 Installing crankshaft sealing ring

- Ensure shims between crankshaft bearing and sealing ring installed in correct sequence.
- Lightly oil sealing lip of new sealing ring.
- Screw tool into crankshaft and tighten guide with sealing ring fitted.

13-15

Removing and installing three groove pulley

- ◀ To loosen and tighten the V-belt pulley attachment bolts, use special tool 3149.

- A – Spanner extension
- B – Counter holder
- C – Support

- turn crankshaft until holes in the pulley are in horizontal position.

Vehicles with rear wheel drive

- Insert tool 3149. (If required, remove bracket –1–).
- Loosen or tighten securing bolt for V-belt pulley.

Tightening torques:
 with spanner extension –A–: 315 Nm
 with normal socket spanner: 350 Nm

Note:

If the silencer cover plate does not have a sufficient indentation in the vicinity of the V-belt pulley, unscrew the plate and push backwards.

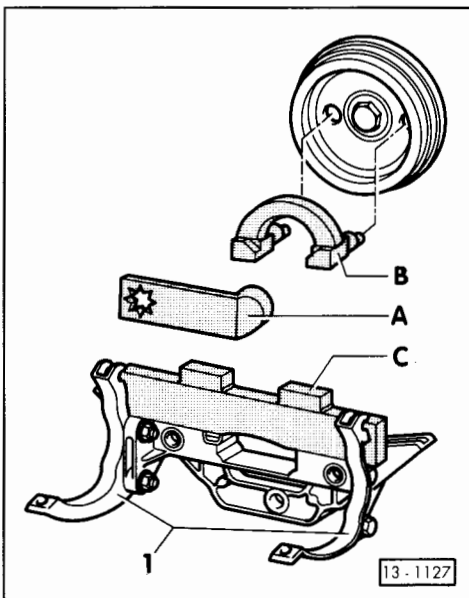

13-16

Synchro

- Remove cover plate.
- ◀ - Install 3149 tool and loosen or tighten V-belt pulley securing bolt.

Tightening torque:
 with spanner extension -A-: 315 Nm
 with normal socket spanner: 350 Nm

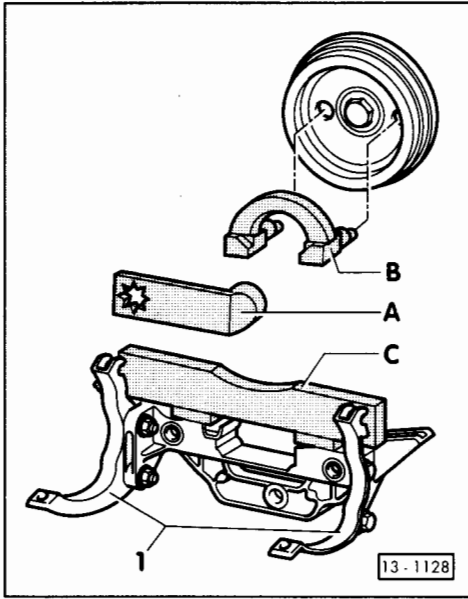

13-17

Checking and adjusting crankshaft axial play

◀ Checking

Play at time of installation	0.07...0.13 mm
Wear limit	0.15 mm

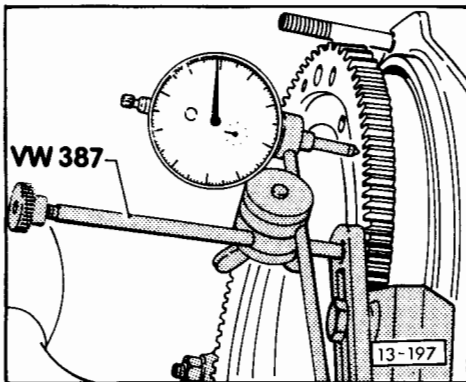

Adjusting

- ◀ - Lightly oil both faces of the thrust washer -1- and install so that the retaining lug points towards the crankshaft bearing.
- Press shim -2- (Ø 81 mm) against thrust washer -1-.
- Install flywheel without sealing rings -5- and -6-.
- Screw dial gauge bracket with dial gauge to crankcase.
- Move crankshaft to and fro in axial direction and read off play on dial gauge.

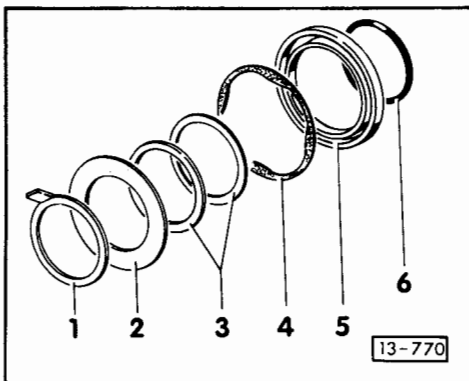

13-18

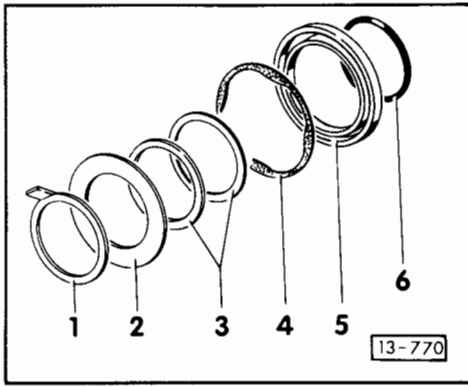

◀ - Calculate thickness of shims -3-:

Dial gauge reading

- 0.10 (mean axial play)

= 2 shims -3-

- Remove flywheel.

- Install shims -3- (Ø 75 mm), retaining washer -4- (Ø 94 mm) and sealing ring -5-.

- Install flywheel with O-ring -6-.

- Recheck axial play.

Note:

The shims are etched with their thickness but, if in doubt, measure thickness again with a micrometer.

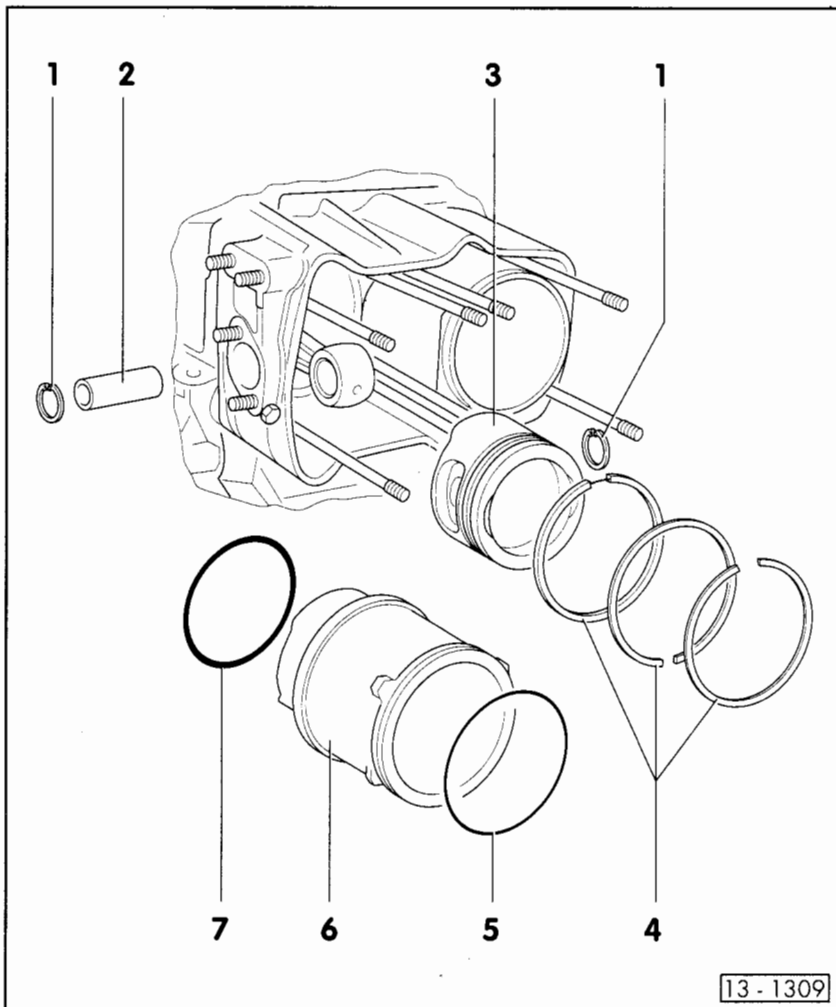

Dismantling and assembling pistons and cylinders

1 - Circlip

- Removing and installing:
on V-belt pulley side ⇒ Fig. 1
On flywheel side with pistons removed

2 - Piston pin

- Removing:
Remove piston pin from cylinder at pulley end first ⇒ Fig. 2
- Installing:
Install piston pin at flywheel end first
⇒ Page 13-29, Installing pistons

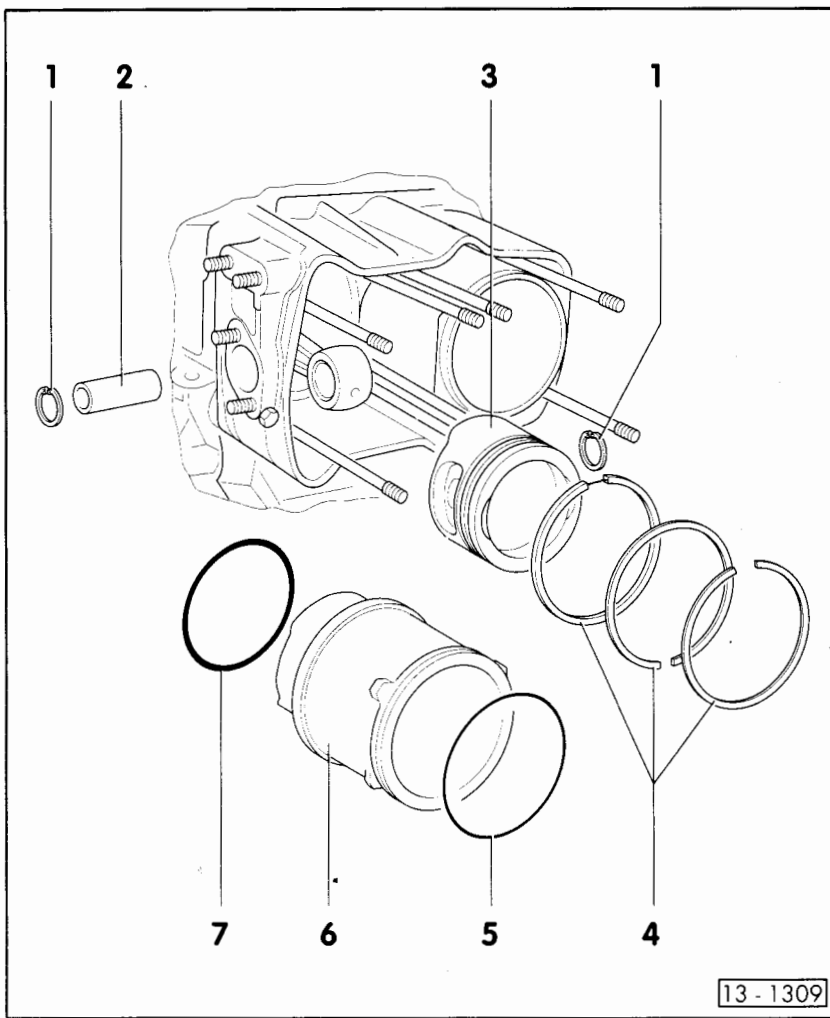

3 – Piston

- Max. weight difference 10 g
- Identification marking ⇒ Fig. 8
- Checking piston dia. ⇒ Fig. 9
- Differentiating features ⇒ Fig. 10
- Allocation of piston to cylinder head ⇒ Page 13–28
- Installing ⇒ Page 13–29

4 – Piston rings

- Offset gap by 180°
- Oil scraper ring gap at top in installation position of piston
- Installation position ⇒ Fig. 5
- Check gap ⇒ Fig. 6
- Checking side clearance ⇒ Fig. 7

5 – Rubber sealing ring

- Thin, green
- Renew

13-21

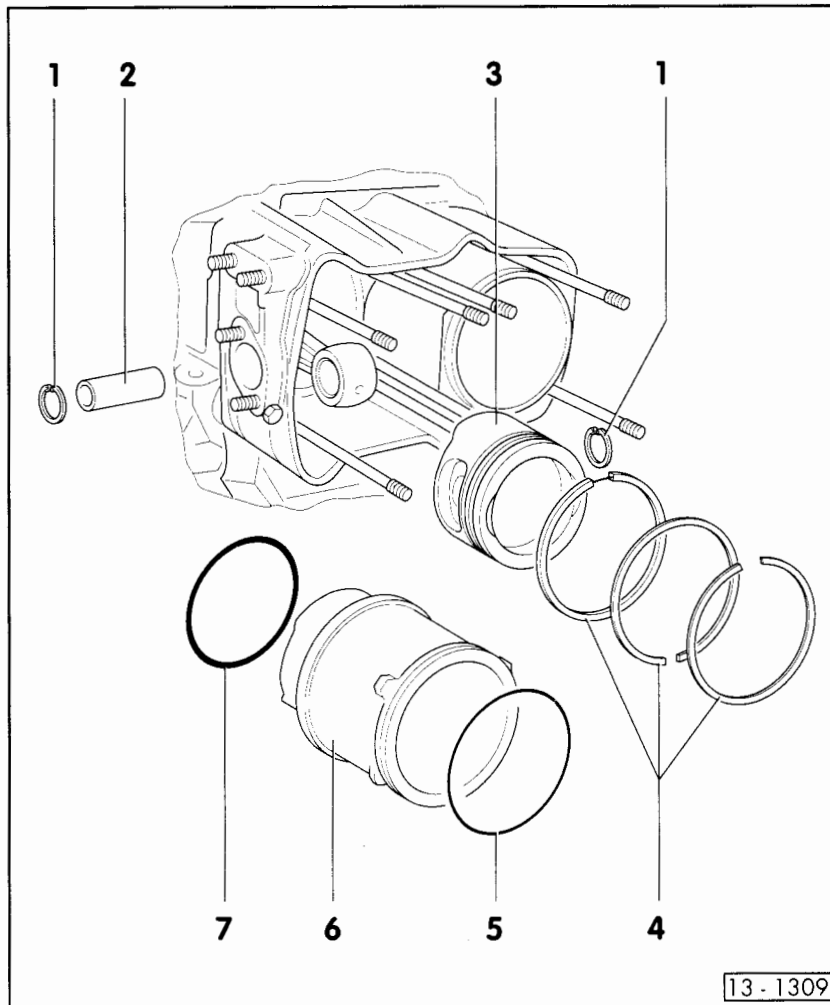

6 – Cylinder

- Before removing mark piston and cylinder ⇒ Fig. 3
- Checking cylinder bore ⇒ Fig. 4
- Installing ⇒ Page 13–30
- Piston and cylinder dimensions ⇒ Page 13–28

7 – Rubber sealing ring

- Thick, black
- Renew

13-22

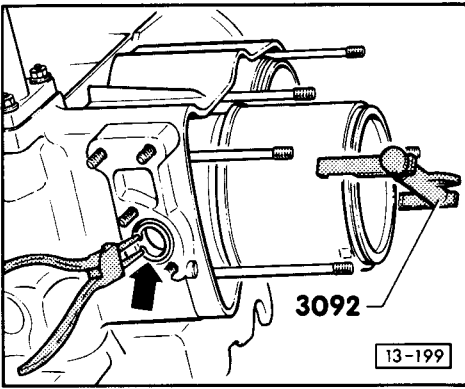

◀ Fig. 1 Removing circlip

- Piston at TDC
- Pull out cylinder with tool 3092 until piston pin eye is free.

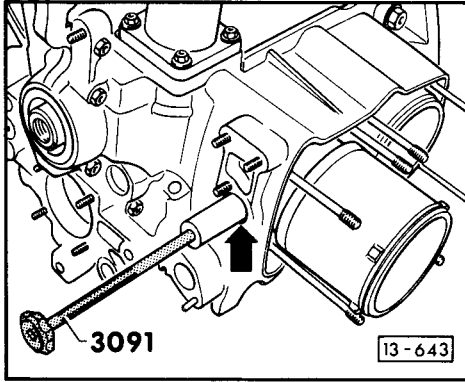

◀ Fig. 2 Removing piston pin

Note:

If the piston pin cannot be pulled out of the piston, remove tool 3091 and remove burr in piston pin hole with reamer 3159.

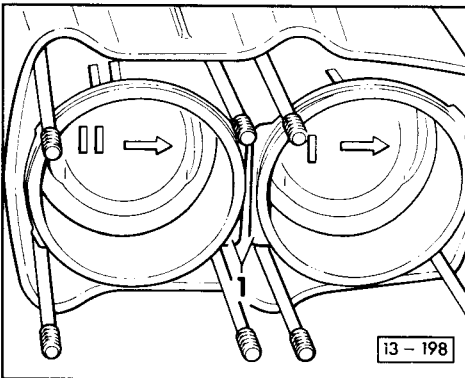

◀ Fig. 3 Marking pistons and cylinders

- Mark matching piston and cylinder. Arrow points towards flywheel. Cylinder boss –1– faces inwards.

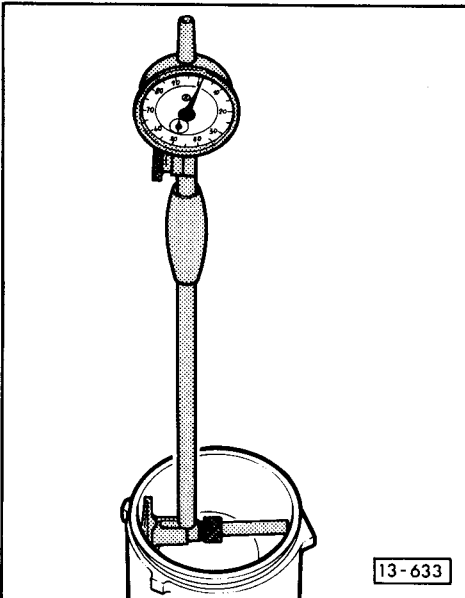

◀ Fig. 4 Checking cylinder bore

- Measure cylinder with 50...100 mm precision internal measurement dial gauge.

Measurements are taken approx. 10...15 mm below the upper edge of the cylinder.

Installation clearance for piston/cylinder

New	0.03...0.06 mm
Wear limit	0.2 mm

Piston and cylinder dimensions ⇒ Page 13–28.

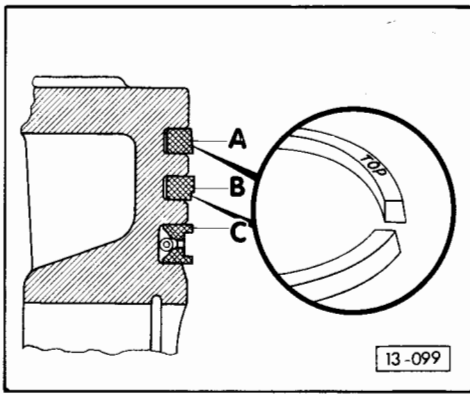

◀ Fig. 5 Piston rings – Installation position

Identification marking TOP points towards piston crown.

- A – Upper compression ring
- B – Lower compression ring
- C – Oil scraper ring

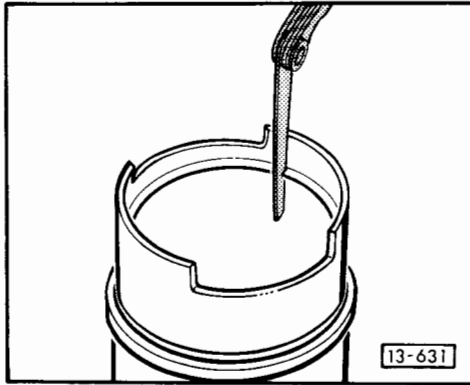

◀ Fig. 6 Checking piston ring gap

– Push ring squarely into lower cylinder groove approx. 4...5 mm from edge of cylinder.

(Dimensions in mm)

Piston ring	Gap	Wear limit
Upper compression ring	0.30...0.45	0.90
Lower compression ring	0.30...0.50	0.90
Oil scraper ring	0.25...0.40	0.95

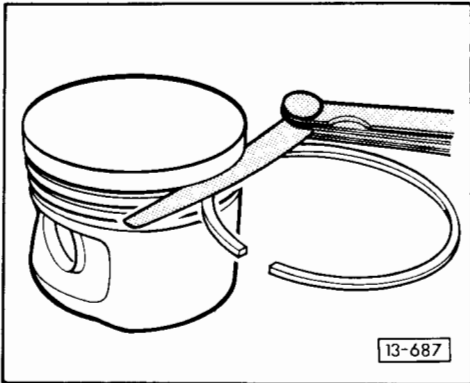

◀ Fig. 7 Checking piston ring clearance

(Dimensions in mm)

Piston ring	Clearance	Wear limit
Upper compression ring	0.05...0.08	0.12
Lower compression ring	0.04...0.07	0.10
Oil scraper ring	0.02...0.05	0.10

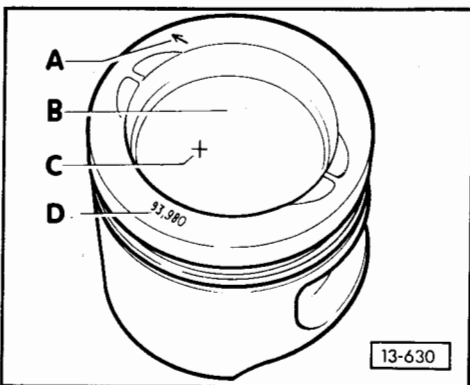

◀ Fig. 8 Marking the piston

- A – Arrow (stamped)
Install piston with arrow pointing towards fly-wheel.
- B – Pairing indicated by coloured spot (blue or pink) ⇒ Page 13–28, Piston and cylinder dimensions.
- C – Indication of weight classification (+ or –), stamped or marked otherwise.
- D – Indication of piston size in mm ⇒ Page 13–28, Piston and cylinder dimensions.

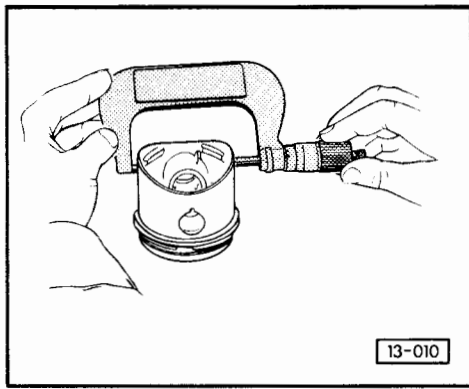

◀ **Fig. 9 Checking piston diameter**

The nominal diameter of the piston is stamped on the piston crown. The reading must be taken at the bottom of the skirt at right angles to the piston pin axis.

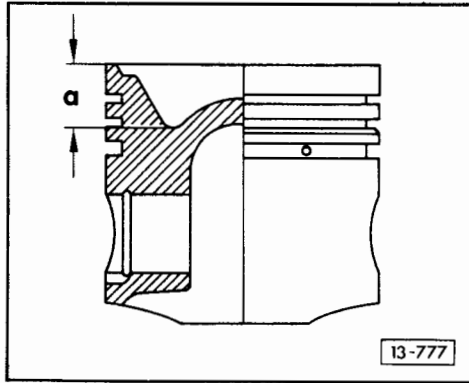

◀ **Fig. 10 Pistons – Differentiating features**

(Dimensions in mm)

Engine code letters	Piston dimension "a"
DJ	9.2
MV, SR, SS	15.5

Matching pistons to cylinder head

Engine code letter	Piston	Cylinder head
DJ	025 107 111 N	025 101 355 C
MV, SR, SS	025 107 111 AF	025 101 355 C

Piston and cylinder dimensions

(Details in mm)

Honing dimensions	Colour	Cylinder Ø	Piston bore Ø
Normal size	Blue	94.005 ... 94.016	93.98
1st oversize	Pink	94.106 ... 94.027	93.99

Installing pistons

- Remove deposits such as scales from around cylinders/crankcase.
- Insert circlip for piston pin on flywheel side the piston.

- ◀ - Push connecting rod support 3090 onto centre stud, support on connecting rod profile and secure with rubber band -1- to prevent it from slipping.

Note markings on connecting rod support:

R = right-hand side of engine

L = left-hand side of engine

- Align connecting rod so that the piston pin can be installed through the hole in the housing. connecting rod bearing should face upwards -arrow-.

- ◀ - Install piston pin with 3091 and insert circlip.

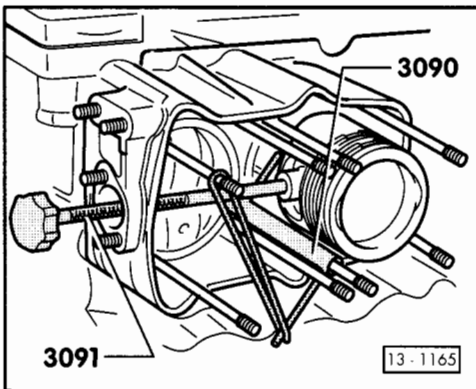
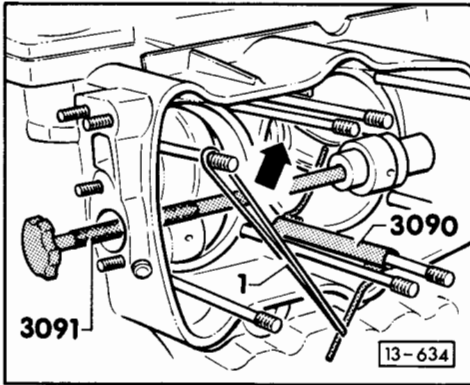

13-29

Installing cylinders

- Remove deposits such as scales from around cylinders/crankcase.
- Renew rubber sealing rings for cylinder.
Cylinder head end = thin ring (green)
Crankcase end = thick ring (black)
- Align piston ring gap at 180° offset (gap of oil scraper ring and first compression ring point upwards).

- ◀ - Install piston ring clamp 3280 so that the clamp opening is not in line with the piston ring gap.

- Slide cylinder over piston rings.
- Remove handles of clamp and pull clamp out over cylinder.
- Push cylinder fully into position.

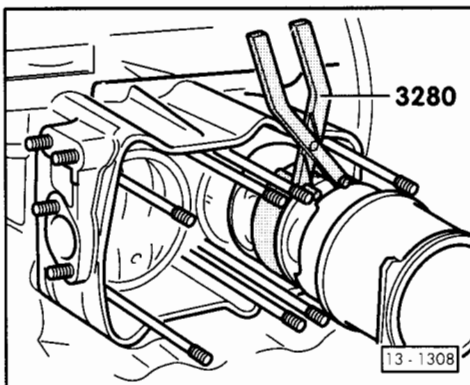

13-30

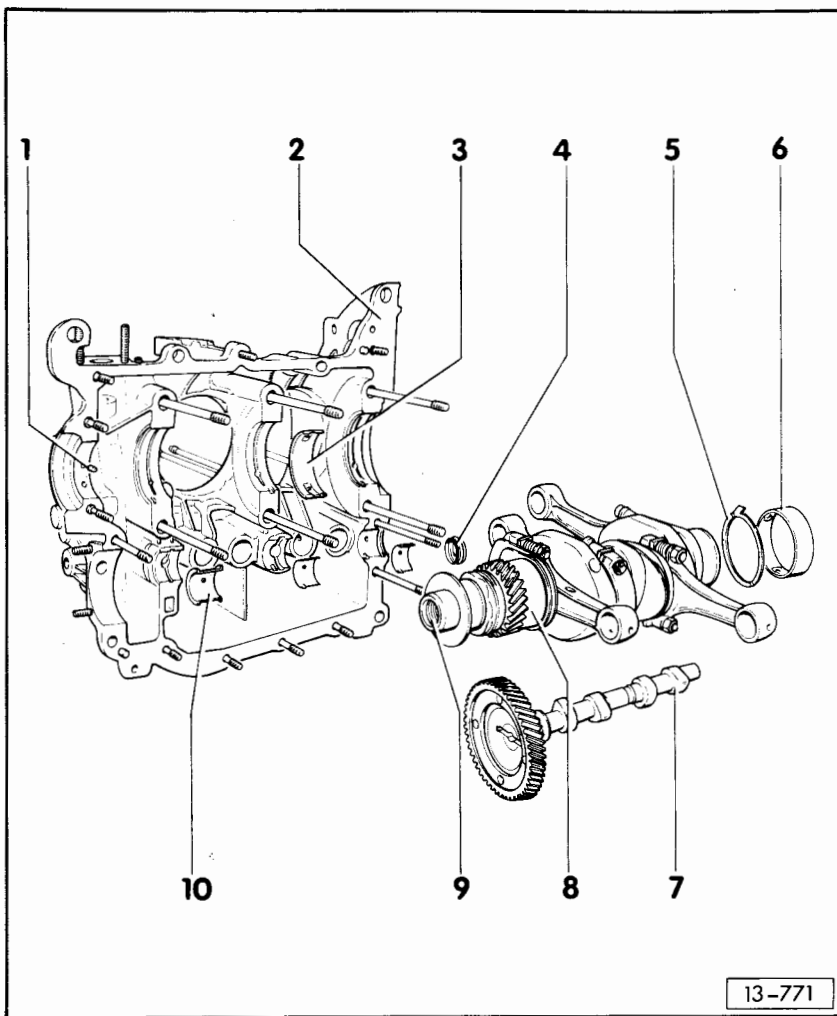

13-771

Dismantling and assembling crankcase

Notes:

- When assembling the crankcase halves note tightening sequence and torques ⇒ Page 13-1, Dismantling and assembling engine.
- Oil suction line with filter: cleaning ⇒ Fig. 1, renewing ⇒ Fig. 2.

1 – Dowel pin

- Ensure tight fit

2 – Crankcase

- Clean, blow oil galleries through with compressed air
- Coat contact surfaces with AMV 188 001 02

13-31

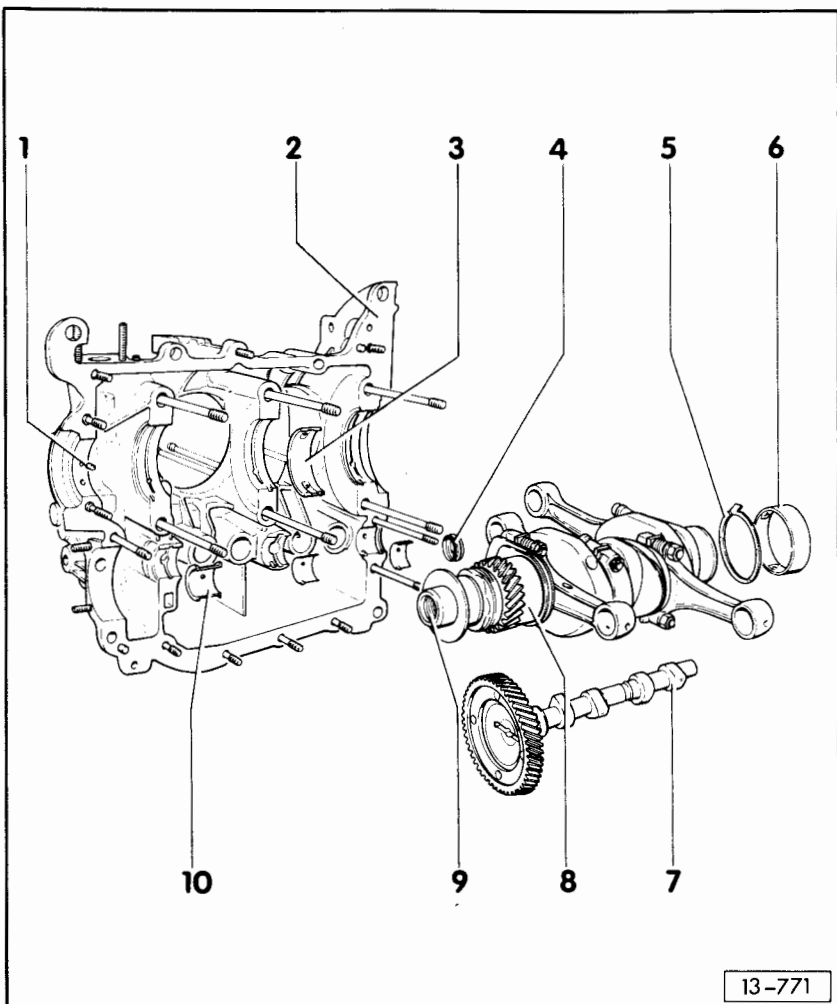

13-771

3 – Crankshaft bearing No. 2

- Colour code blue or red according to crankshaft dimensions ⇒ Page 13-49
- Lubricate with oil
- Locating lugs engage in crankcase recesses

4 – Camshaft end cap

- Lubricate with AMV 188 001 02 and install

5 – Thrust washer

- Locating lug points towards crankshaft bearing and joint ⇒ Fig. 3

6 – Crankshaft bearing No. 1

- Colour code blue or red according to crankshaft dimensions ⇒ Page 13-49
- Lubricate with oil
- Oil drillings point towards left-hand crankcase half
- Locating lugs engage in crankcase recesses ⇒ Fig. 3

13-32

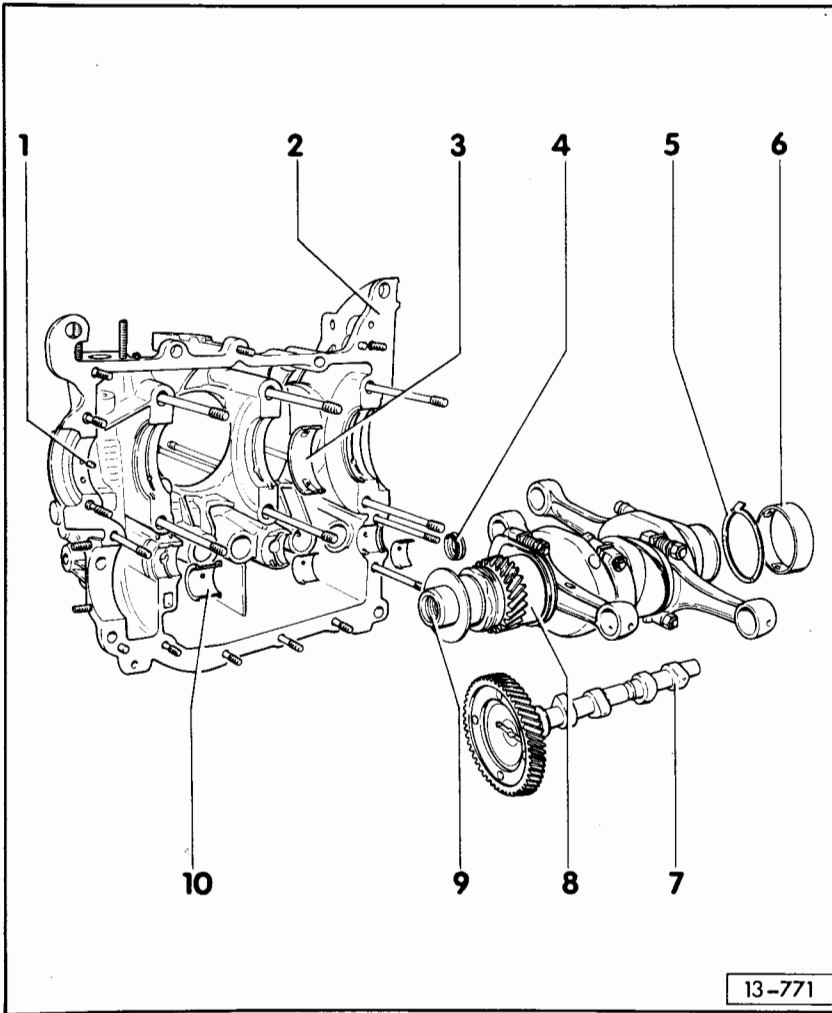

7 – Camshaft

- Marking, timing settings ⇒ Fig. 4
- Checking run-out ⇒ Fig. 5
- Checking axial clearance ⇒ Fig. 6
- Note installation position ⇒ Fig. 7

8 – Crankshaft bearing No. 3

- Colour code blue or red according to crankshaft dimensions ⇒ Page 13-49
- Lubricate with oil
- Oil drillings point towards left-hand crankcase half
- Locating lugs engage in crankcase recesses

9 – Crankshaft

- Dismantling and assembling ⇒ Page 13-38

10 – Camshaft bearing

- Lubricate with oil
- Locating lugs engage in crankcase recesses

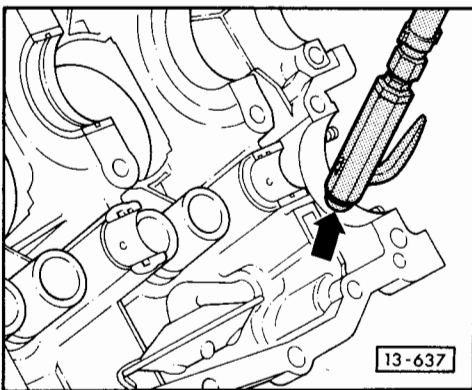

◀ Fig. 1 Suction line with filter screen – cleaning

- Blow oil drillings in camshaft bearing through with compressed air.

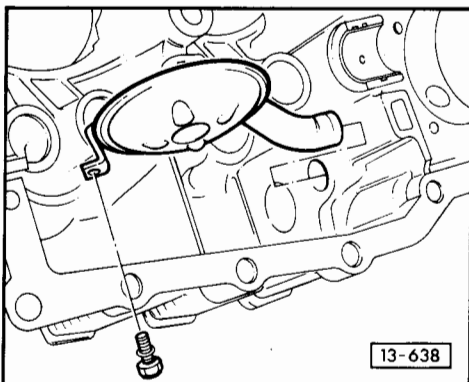

◀ Fig. 2 Suction line with filter screen – renewing

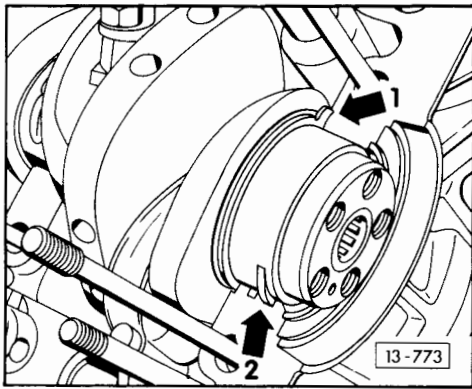

◀ Fig. 3 Installing thrust washer and crankshaft bearing No. 1

Thrust washer locating lug points towards crankshaft bearing and crankcase joint –arrow 1–.

Crankshaft bearing locating lugs engage in the crankcase recesses. Oil drillings pint towards left-hand crankcase half –arrow 2–.

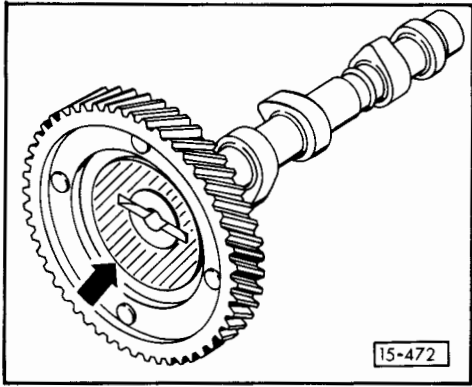

◀ Fig. 4 Camshaft marking, timing settings

Marking

Front face of camshaft with blue colour code.

Timing settings with 1 mm valve lift

Inlet opens:	10° before TDC
Inlet closes:	48° after BDC
Outlet opens:	50° before BDC
Outlet closes:	TDC

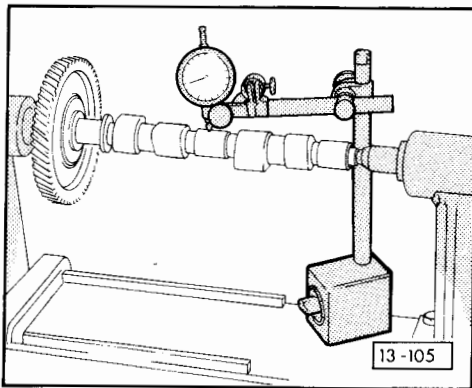

◀ Fig. 5 Camshaft – Checking for run-out

Max. 0.04 mm

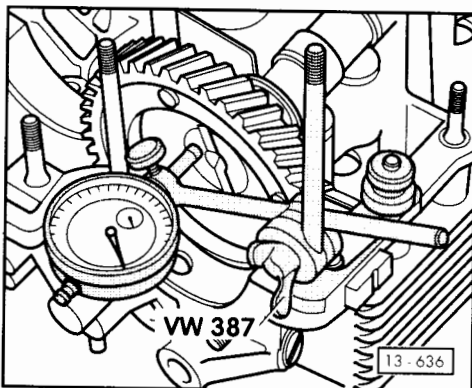

◀ Fig. 6 Camshaft – Checking axial clearance

Max. 0.16 mm

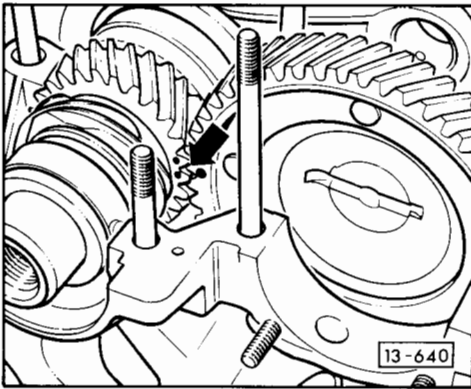

◀ Fig. 7 Installing camshaft

The camshaft marking must be between the crankshaft gear markings –arrow–.

Notes:

- The backlash between camshaft and crankshaft gears is 0...0.05 mm. The camshaft gear size is correct if the backlash is noticeable and the camshaft does not lift when the crankshaft is rotated backwards.
- In order to assist in obtaining the specified backlash camshafts are available with various sizes of timing gears under different part numbers.
- The gears are marked below the gear teeth on the surface facing the cams by stamped numbers such as, for example, -1.0, + 1, + 2 etc. The number indicates in 1/100 mm by how much the pitch radius differs from the standard pitch radius indicated as size 0.
- Do not confuse the number 0 with the marking O, which is used for setting the timing gears. Crankshaft timing gears are identical and have no special markings.

13-37

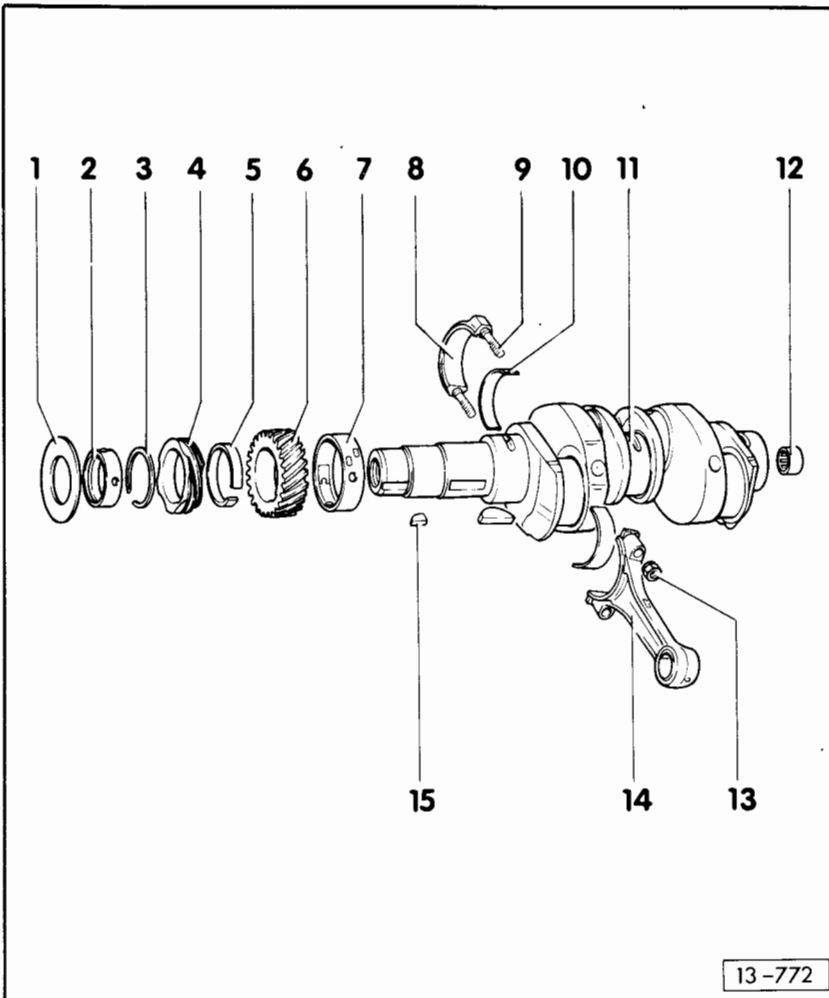

Dismantling and assembling the crankshaft

- 1 – Oil deflector washer
- 2 – Crankshaft bearing No. 4
 - Lubricate with oil
 - Groove faces towards oil deflector washer
- 3 – Circlip
 - Removing ⇒ Fig. 1
 - Installing ⇒ Fig. 2
- 4 – Distributor drive gear
 - Remove together with crankshaft gear ⇒ Fig. 3
 - Install as crankshaft gear ⇒ Fig. 4
 - First heat up to approx. 80°C
- 5 – Intermediate ring
- 6 – Crankshaft gear
 - Removing ⇒ Fig. 3
 - Installing ⇒ Fig. 4
 - First heat up to 80°C

13-38

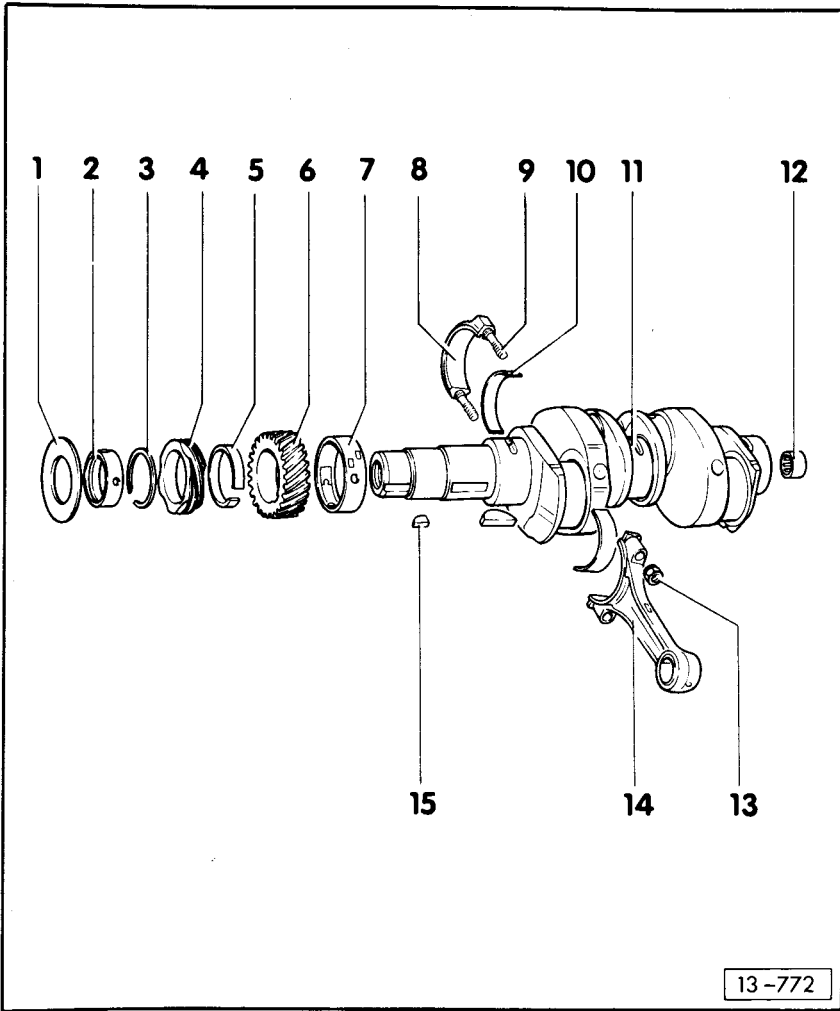

- 7 – Crankshaft bearing No. 3**
 - Colour code blue or red according to crankshaft dimensions
⇒ Page 13-49
 - Lubricate with oil
 - Note installation position:
Locating lugs face to the right and oil drillings downwards

- 8 – Connecting rod bearing cover**
 - Mark to match cylinder ⇒ Fig. 5

- 9 – Connecting rod bearing bolt**
 - Renew
 - Carefully tap out of bearing cover with hammer
 - Installing ⇒ Fig. 6

- 10 – Bearing shell**
 - Note installation position
 - Do not interchange

13-772

13-39

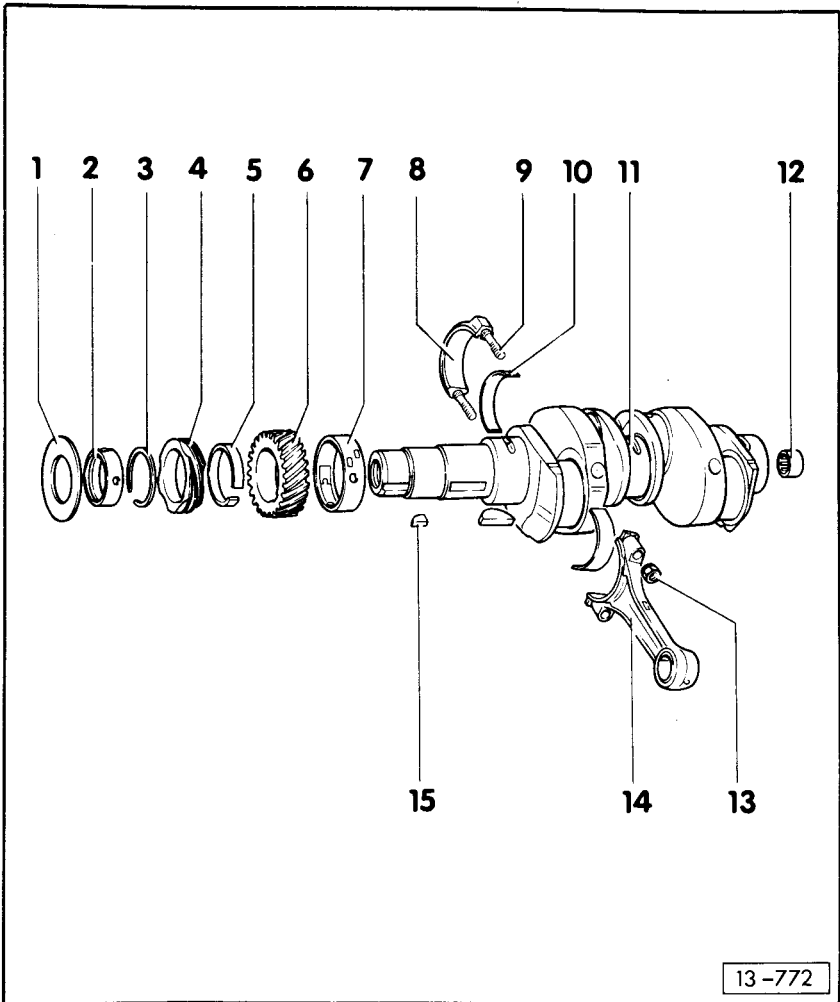

- 11 – Crankshaft**
 - Clean
 - Blow oil passages through with compressed air
 - Do not store without anti-corrosion protection
 - Marking ⇒ Fig. 7
 - Clamping ⇒ Fig. 8
 - Crankshaft dimensions
⇒ Page 13-49

- 12 – Needle roller bearing**
 - Only with manual gearbox
 - Removing ⇒ Fig. 9
 - Installing ⇒ Fig. 10
 - Lubricate with G 000 100

- 13 – 30 Nm + further 1/2 turn (180°)**
 - Oil contact surface

13-772

13-40

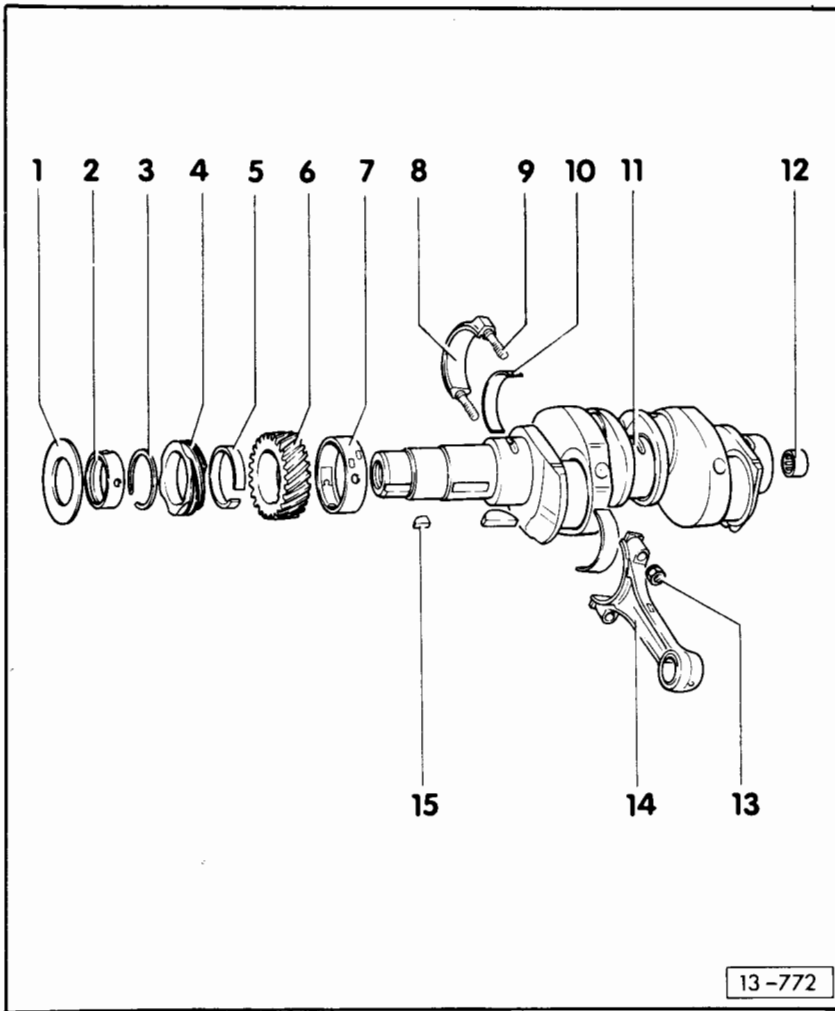

- 14 – Connecting rod**
- Only renew as a set
 - Mark connecting rod/bearing cap with cylinder number ⇒ Fig. 5
 - Note installation position ⇒ Fig. 12
 - Installing ⇒ Fig. 11
 - Checking axial clearance ⇒ Fig. 13
 - Max. weight difference 10 g

- 15 – Woodruff key**
- Note installation position: Flat end faces oil deflector washer

13-41

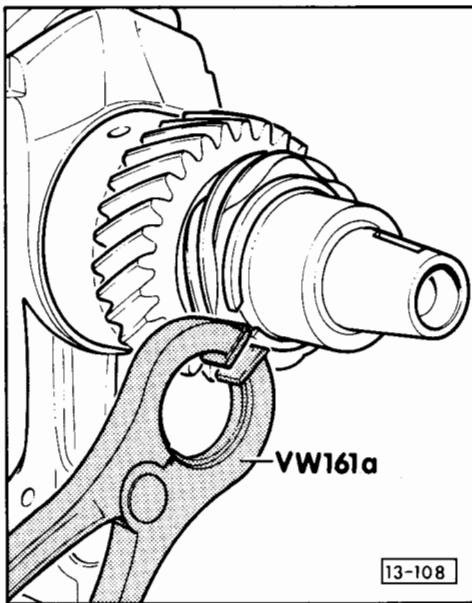

◀ Fig. 1 Removing circlip

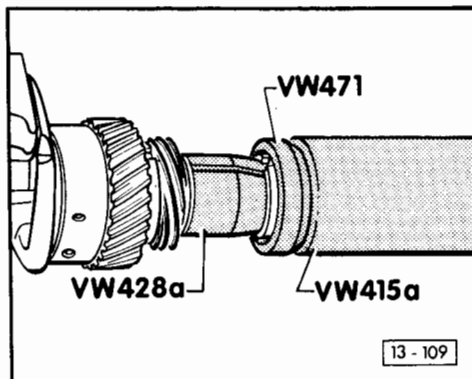

◀ Fig. 2 Installing circlip

13-42

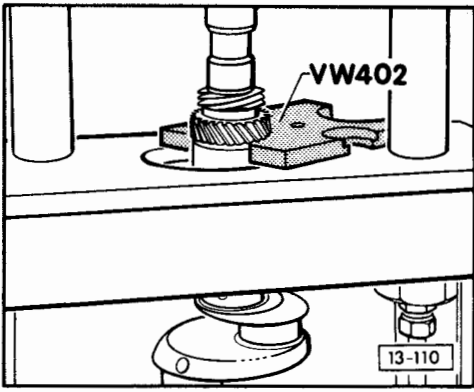

◀ Fig. 3 Removing crankshaft gear with distributor drive gear

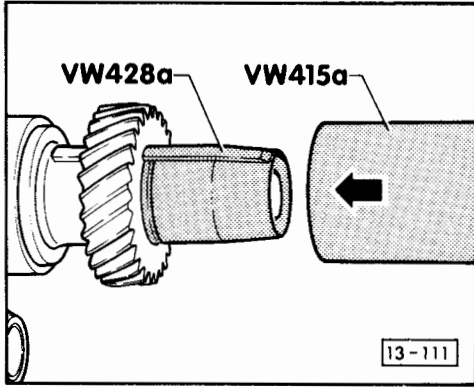

◀ Fig. 4 Installing crankshaft gear with distributor drive gear

13-43

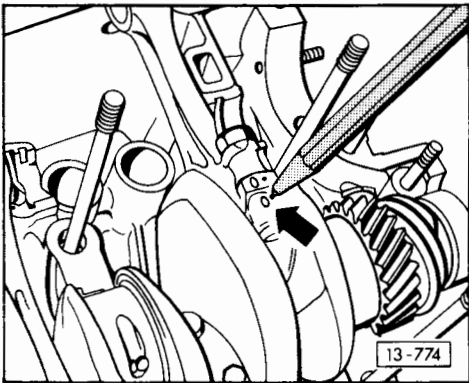

◀ Fig. 5 Marking connecting rod/bearing cap with cylinder number

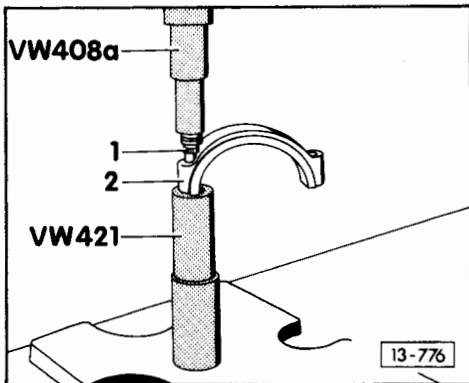

◀ Fig. 6 Installing connecting rod bearing bolt

- 1 - Connecting rod bearing bolt.
- 2 - Bearing cover.

13-44

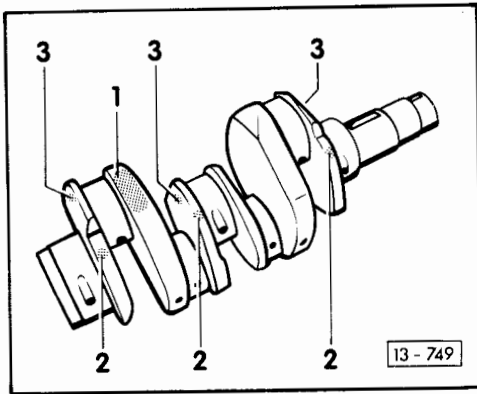

◀ Fig. 7 Colour coding of crankshaft

- 1 – Colour coding green:
Identifies crankshaft for 2.1 ltr. engine.
- 2 – Colour coding blue or red:
Identification for crankshaft bearing (⇒ Table on page 13–49). Some crankshafts have this colour coding in the position marked –3–.

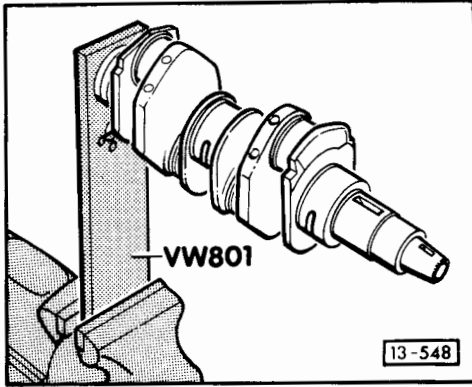

◀ Fig. 8 Clamping crankshaft

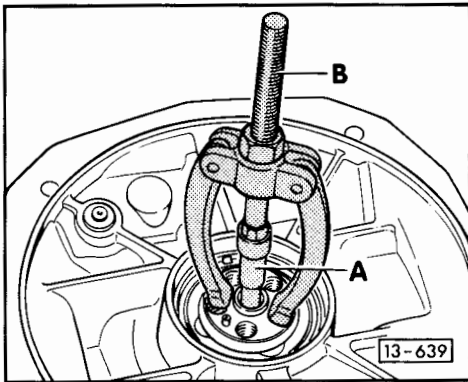

◀ Fig. 9 Removing needle roller bearing

- A – Internal extractor \varnothing 14.5 ... 18.5 mm such as
Kukko 21/2
- B – Counter hold such as Kukko 22/1

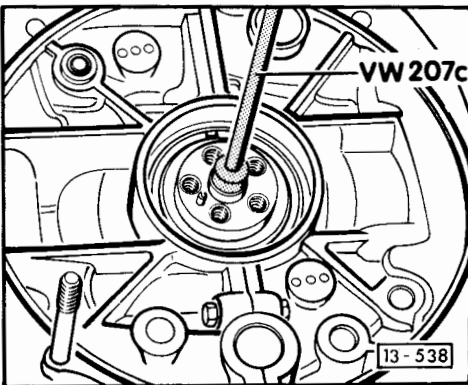

◀ Fig. 10 Installing needle roller bearing

When installed lettered side of needle roller bearing must be legible.

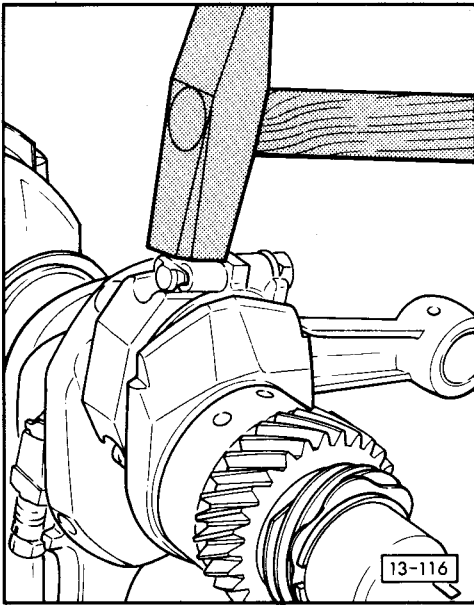

◀ Fig. 11 Installing connecting rod

Slight pinching which can occur between the bearing halves during tightening the connecting rods can be eliminated by light tapping with a hammer on both sides of the connecting rod.

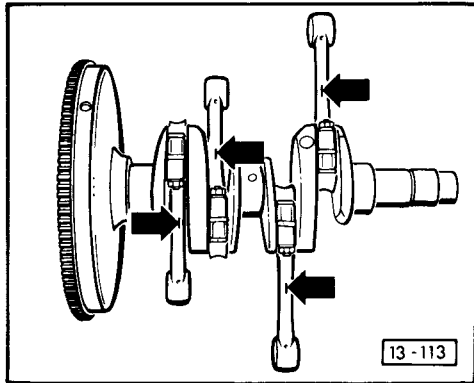

◀ Fig. 12 Connecting rods – Installation position

The forged mark on the connecting rod must face upwards when rods are installed.

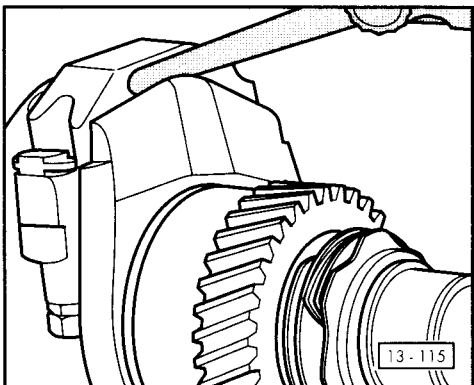

◀ Fig. 13 Connecting rod – Checking axial clearance

Max. 0.7 mm

Crankshaft dimensions

(Details in mm)

Honing dimension	Crankshaft bearing journal Ø			Connecting rod bearing journal Ø
	Bearing 1	Bearings 2 and 3	Bearing 4	
Standard size	-0.010	-0.010		-0.004
	blue	blue		
	-0.020	-0.020		55.00
	60.00	55.00	40.00 - 0.016	
	-0.021	-0.021		
red	red		-0.017	
-0.029	-0.029			

Note:

Depending on the coloured spot, blue or red, on the crankshaft (⇒ also page 13-45, Fig. 7), only crankshaft bearings with identical colour coding may be installed.

Identification of crankshaft bearings 1, 2 and 3: 001 = blue
004 = red

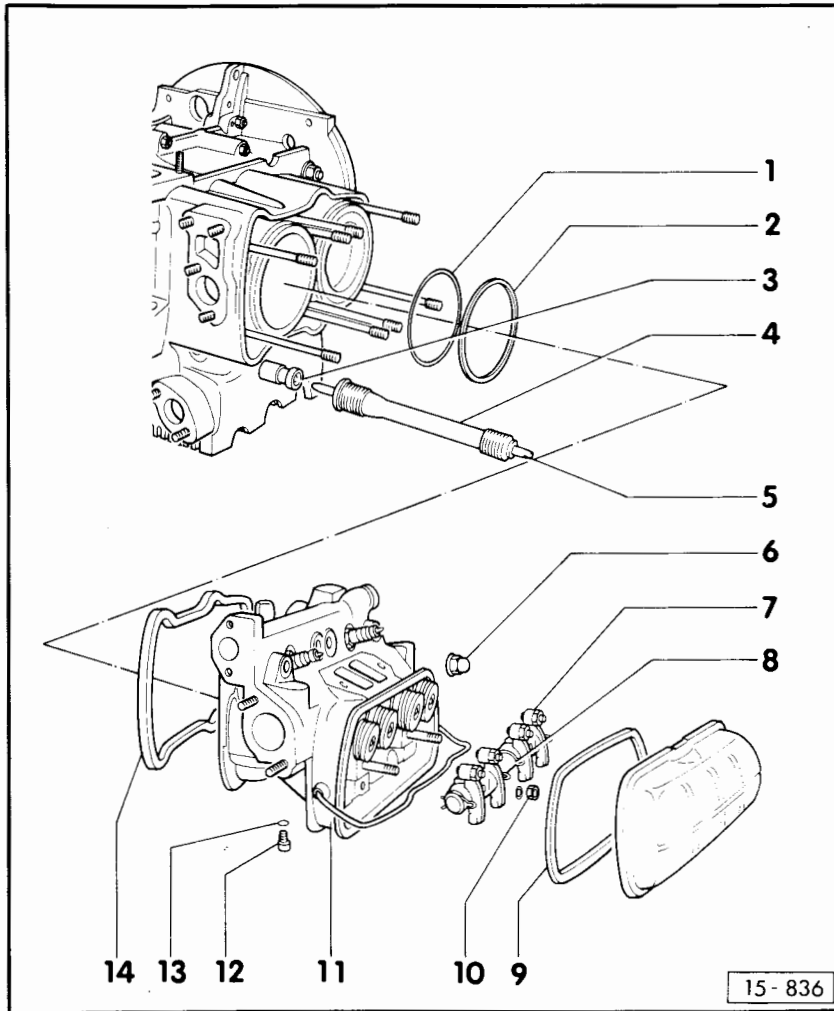

Removing and installing cylinder head

Note:

Cylinder heads can be removed and installed with the engine in situ.

Checking compression pressures
⇒ Page 15-11.

1 – Rubber sealing ring

- Thin, green
- Renew

2 – Metal sealing ring

- Renew

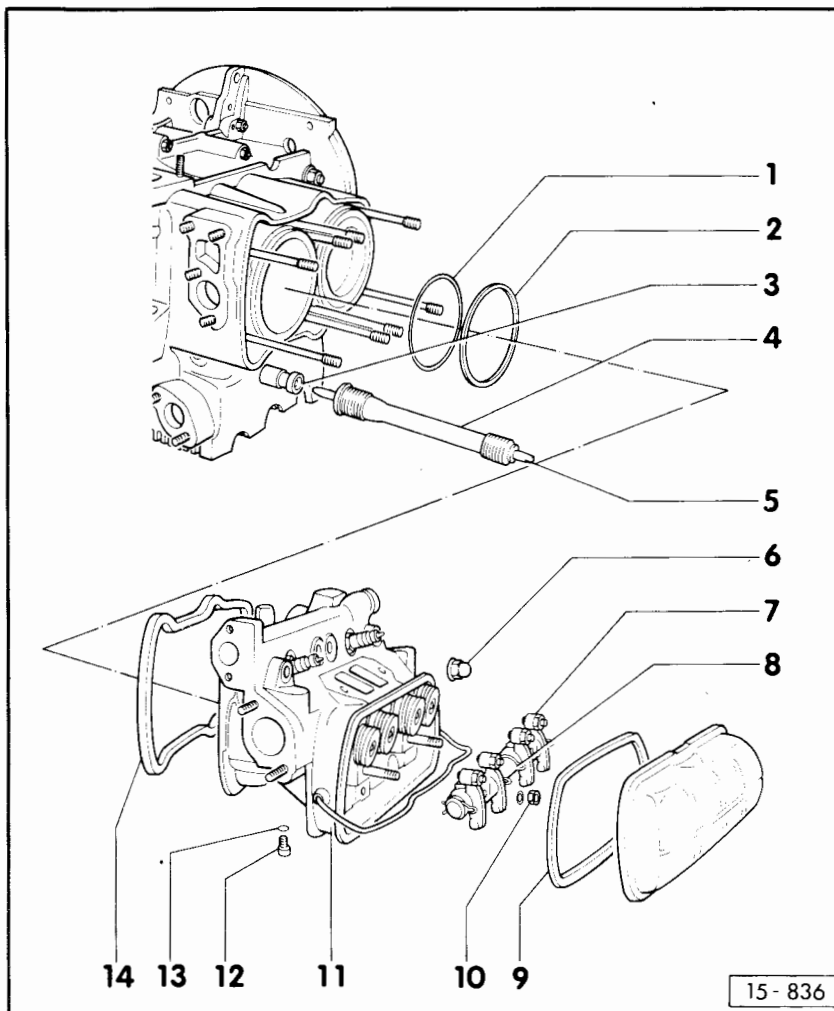

3 – Hydraulic tappet

- Do not interchange
- Store vertically with tappet base downwards
- Repair instructions for hydraulic tappet adjustment ⇒ Page 15-5
- Installing ⇒ Page 15-6
- Bleeding ⇒ Page 15-7

4 – Push rod tube

- Seam faces upwards
- Renew sealing rings
- Preloading ⇒ Fig. 1
- Can be renewed with engine installed
- Removing and installing ⇒ Page 15-10

5 – Push rod

- Max. run-out 0.3 mm
- Carefully guide push rod into socket of tappet (finger check)

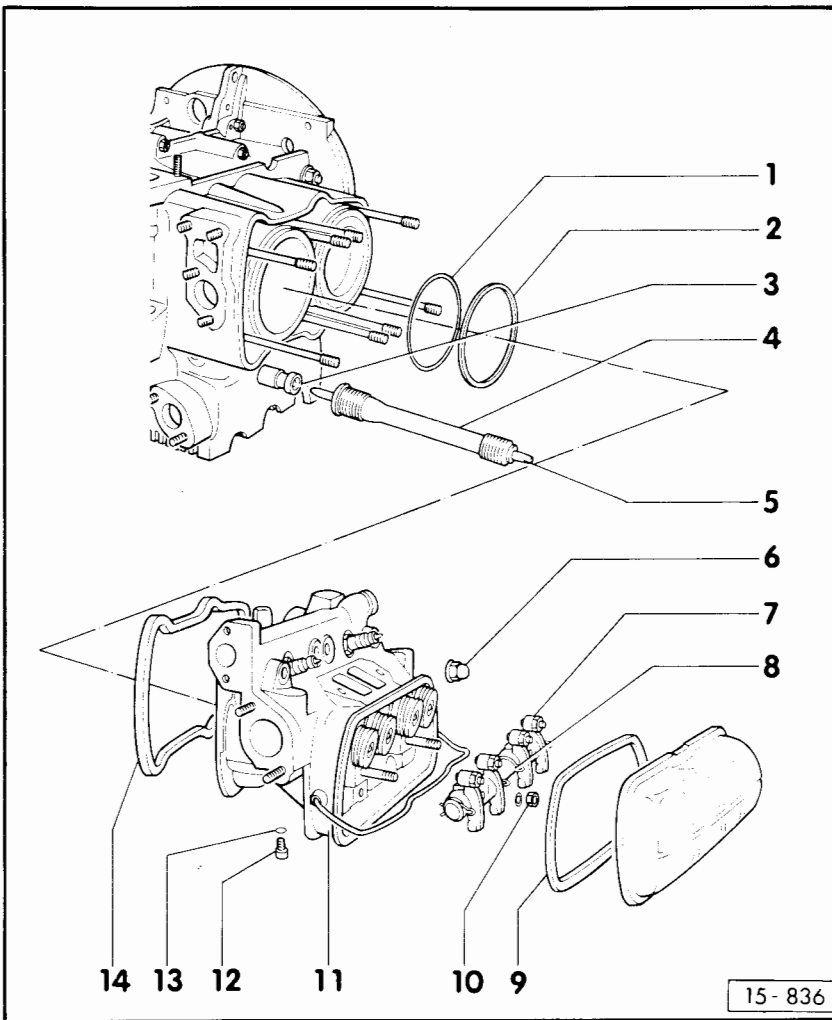

- 6 – 50 Nm
 - Drain coolant before loosening
 - Coat cleaned and degreased contact surface of the cap nut (or washer of cap nut) with AKD 456 000 01
 - Tightening sequence
⇒ Page 15-8, Installing cylinder head

- 7 – Adjusting screw
 - Basic adjustment of hydraulic valve gear ⇒ Page 15-9

- 8 – Support
 - Slot faces upwards

- 9 – Gasket
 - Renew if damaged

- 10 – 25 Nm

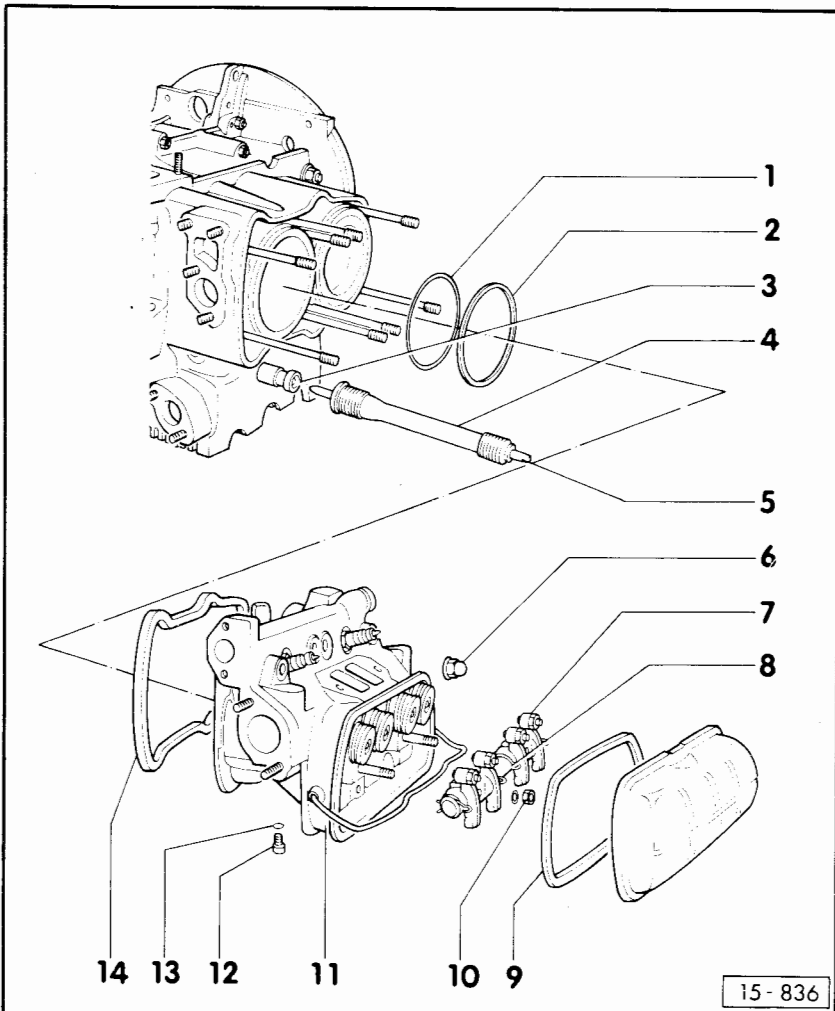

- 11 – Cylinder head
 - Drain coolant at drain plug
 - Installing ⇒ Page 15-8
 - Servicing ⇒ Page 15-13

- 12 – Coolant drain plug 15 Nm

- 13 – Sealing ring
 - Renew

- 14 – Gasket
 - Renew
 - Apply sealant D 000 400
⇒ Page 15-8, Installing cylinder head

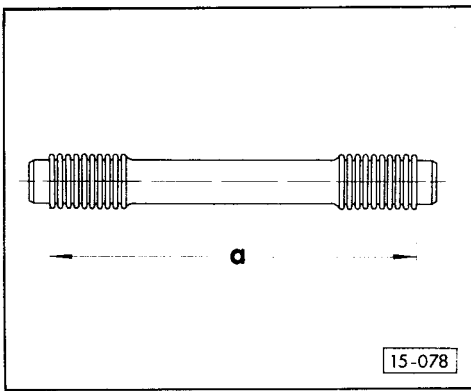

◀ Fig. 1 Preloading push rod tube

a = approx. 194 mm

Instructions on servicing hydraulic valve adjustment

- The hydraulic valve adjustment is maintenance-free.
- Hydraulic tappets cannot be repaired. When faulty, renew push rod complete.
- Valve noise after starting the engine or during deceleration after engine has been under load at high ambient temperatures and RPM are of no significance.

15-5

- If metal particles are found in the crankcase after main and connecting rod bearing failure, dismantle the tappets one after the other and clean. Do not interchange individual components of the tappets.
- Dismantling and assembling ⇒ Page 15-7, Bleeding hydraulic tappets.

Installing hydraulic tappets

- ◀ Before tappets are installed they must be checked for air in the pressure chamber. Thumb pressure will suffice for this. When the plungers are pressed firmly with the thumb (in direction of arrow) the plungers must not give. If they do, they must be bled ⇒ Page 15-7, Bleeding hydraulic tappets.

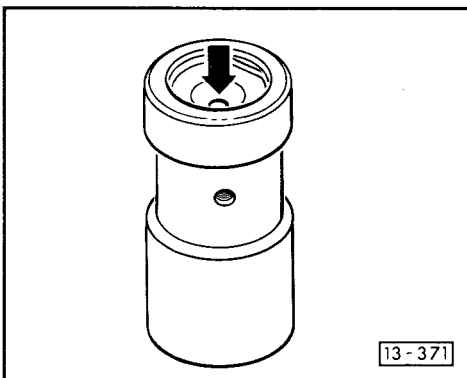

15-6

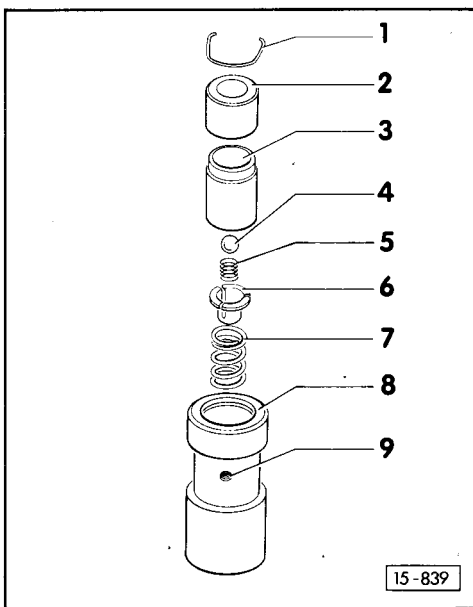

Bleeding the tappets

- ◀ - Lever out circlip -1- and remove push rod socket -2-, piston with valve -3-, -4-, -5-, -6- and plunger spring -7-.
- Fill tappet -8- with oil up to drilling -9-.
- Install plunger spring -7-.
- Install plunger -3- with valve -4-, -5- and -6- and press downwards. At the same time open ball valve -4- with a scriber.

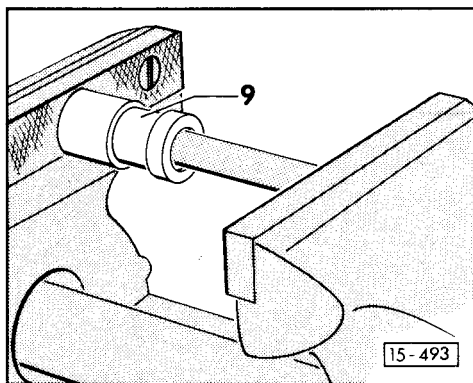

- ◀ - Insert push rod socket -2- and slowly press together with valve guide or sawn-off push rod in vice (bore -9- must face upwards) or in repair press until the circlip -1- can be inserted.
- Insert circlip -1-.

15-7

Installing the cylinder head

Note:

If only the cylinder head was removed, carry out the following action before installing the cylinder head: strip cylinder, remove deposits such as scales, renew sealing rings, install cylinder ⇒ Page 13-30.

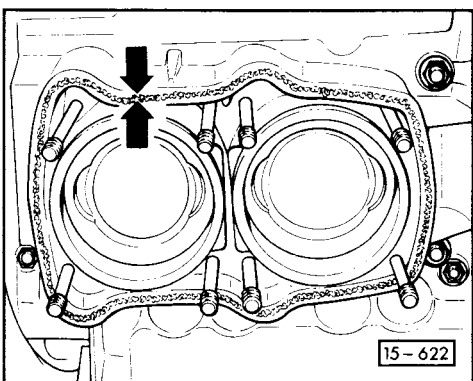

- If the paintwork is damaged, dress cylinder head sealing surface with fine sand paper.
- Clean sealing surfaces with cleaning benzene.

- ◀ - Apply a 1...2 mm thick run of sealant D 000 400 in the centre of the new gasket -arrows- (cut off cartridge nozzle at an angle at first step).

Notes:

- Do not apply sealant too thickly, as it could block coolant holes in cylinder head.
- Cylinder head must be fully tightened down not later than 45 minutes after applying the sealant.

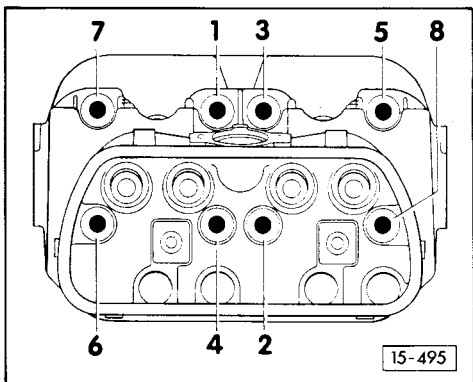

- Coat cleaned and degreased contact surface of cap nuts (or cap nut washers) with AKD 456 000 01.

- ◀ - Pre-tighten cap nuts in specified sequence to 10 Nm.

15-8

Note:

Ensure that push rod tubes are properly seated.

- Tighten cap nuts to 50 Nm.

Basic adjustment of hydraulic valve gear

Note:

The hydraulic tappets are maintenance-free. The basic setting must not be altered. Guide push rods carefully into sockets in tappets (finger check). If push rods rest on the edge of the tappets the basic setting will be incorrect and tappets will be damaged when the engine is rotated.

The following basic adjustment is required after the rocker arms have been installed:

- Turn adjusting screws in rocker arms back until they are flush with the rocker arms.
- Set No. 1 cylinder to TDC (rotor arm must point to No. 1 cylinder marking on distributor housing).

15-9

- Turn both rocker arm adjusting screws lightly against the valves (no valve gear clearance).
- From this position turn screws in two further turns and tighten lock nuts.
- To adjust the tappets of No. 2, 3 and 4 cylinder turn crankshaft to the left until the rotor arm moves 90° for each cylinder.

Removing and installing push rod tubes

A telescopic push rod tube is supplied as a replacement part, which can be installed as follows with the engine installed:

- Take off cylinder head cover, remove rocker shaft and pull the push rod out.
- Remove cover plate.
- Press out defective push rod tube with pliers or a screwdriver.
- ◀ - Compress telescopic push rod tube together with new seals and insert in direction of arrow.

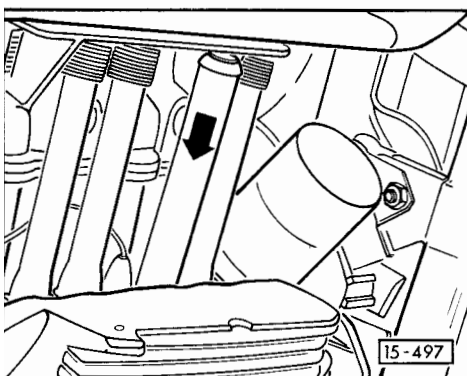

15-10

- Insert push rod and rocker shaft.

Note:

Guide push rods carefully into socket in tappet (finger check). If the rod rests on the edge of the tappet the basic setting will be incorrect and tappets will be damaged when the engine is rotated.

- Adjusting hydraulic valve gear ⇒ Page 15-9, Basic adjustment of hydraulic valve gear.

Checking compression pressure

- Engine oil temperature at least 30°C.
- Disconnect Hall sender plug (distributor).
- Open throttle valve fully.
- Check compression pressure with compression pressure tester V.A.G 1381.

Note:

Operation of tester ⇒ Operating instructions.

- Operate starter motor until measuring device no longer indicates a rise in pressure.

15-11

Compression pressures

(bar)

Engine code letters	New	Wear limit
DJ	11...14	8
MV, SR, SS	10...13	8

Max. permissible pressure difference between all cylinders is 3 bar.

Servicing cylinder head

Note:

Cylinder heads with cracks between the valve seats or between a valve insert and the spark plug thread can be used again without reducing service life provided that the cracks are small and not more than 0.5 mm wide or that only the first threads of the spark plug thread are cracked.

1 – Valves

- Only grind in, do not rework
- Valve dimensions ⇒ Fig. 1

2 – Valve guides

- Wear limit: 1.2 mm
- Checking ⇒ Page 15–18

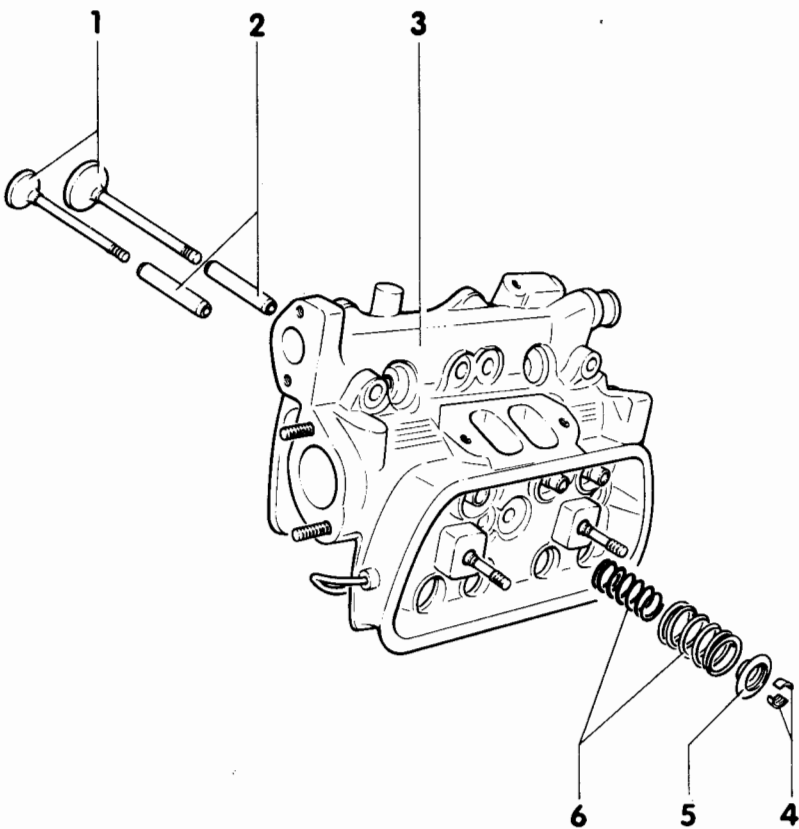

15-040

15-13

3 – Cylinder head

- Reworking valve seats
⇒ Page 15–16

4 – Valve collets

5 – Valve spring retainer

6 – Valve springs

- Removing and installing ⇒ Fig. 2

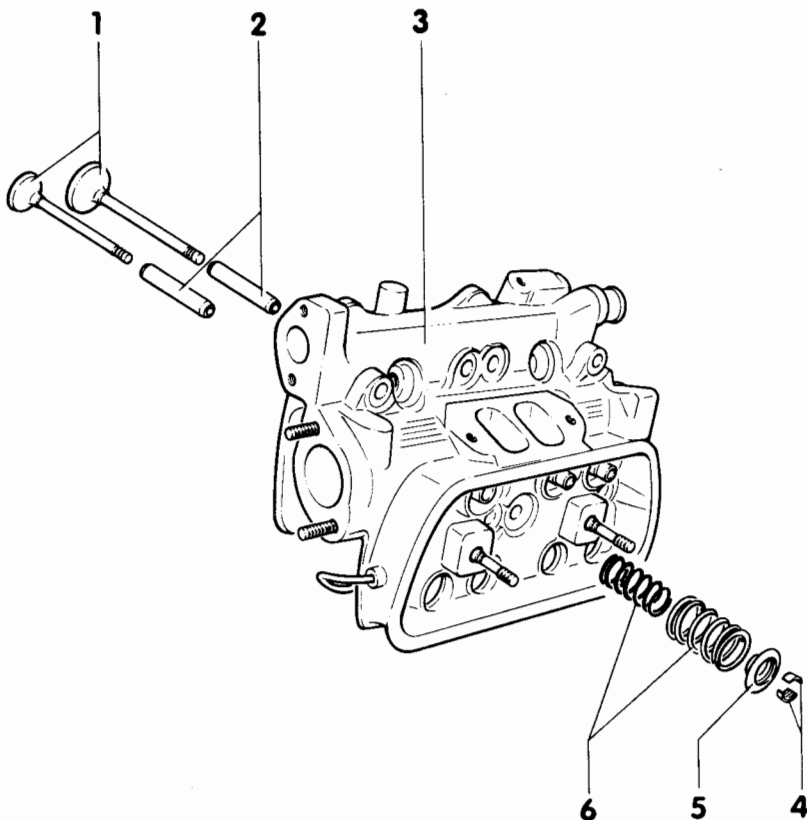

15-040

15-14

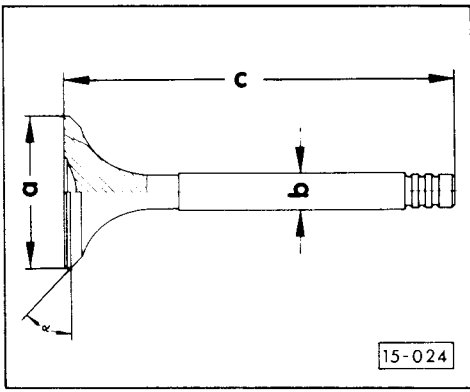

◀ Fig. 1 Valve dimensions

Note:

Valves must not be reworked, only grinding in is permitted.

Engine code letters	Inlet valve (mm)	Exhaust valve (mm)
DJ, MV, SR, SS	a = Ø 40.00 b = Ø 7.96...7.97 c = 122.50 α = 45°	a = Ø 34.00 b = Ø 8.91...8.92 c = 122.50 α = 45°

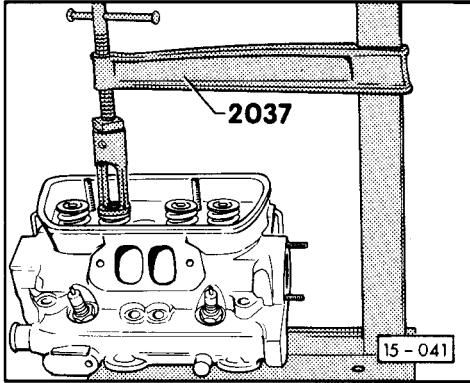

◀ Fig. 2 Removing and installing valve springs

Refacing valves seats

Checking valve guides ⇒ Page 15-18.

Notes:

- When servicing cylinder heads with leaking valves it is not sufficient to rework or renew the valve seats and valves. This applies especially to engines which have done considerable mileage, where it is absolutely necessary to check the valve guides for wear.
- Worn or burnt valve seats can be reworked as long as the permissible seat width is maintained and the outer circumference of the 15° chamfer does not exceed the outer diameter of the valve seat insert. If the dimensions are no longer within limits, the cylinder head must be replaced by a new or reconditioned one.

Max. permissible valve seat width

◀ a = 1.4...2.5 mm

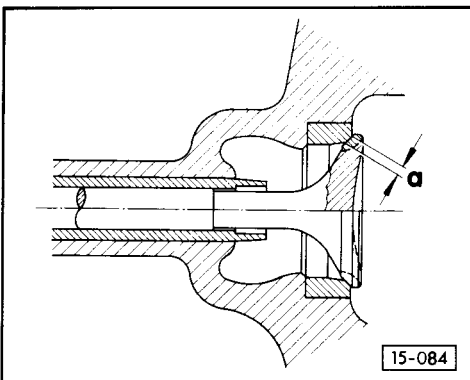

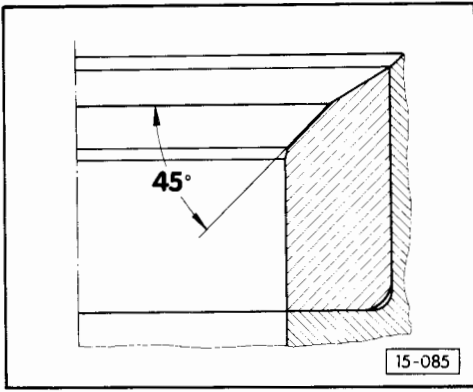

◀ Refacing 45° seat surface

Refacing is completed as soon as the total seat surface has been covered.

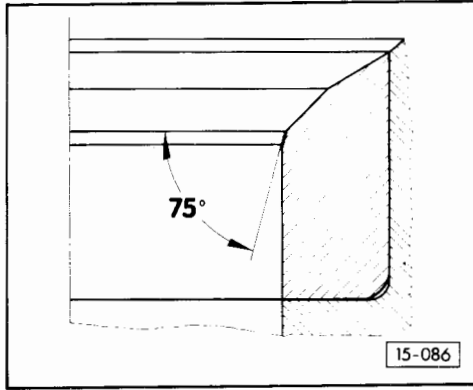

◀ Reworking 75° surface

- Slightly chamfer the lower edge of the valve seat insert.

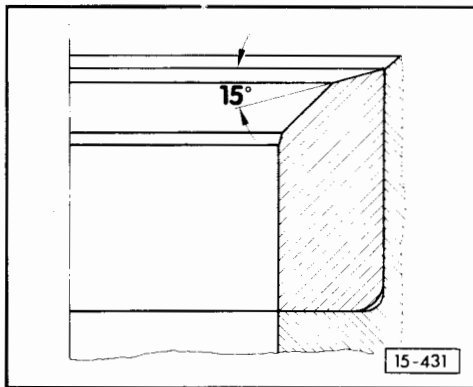

◀ Reworking 15° surface

- Chamfer upper edge of the valve seat insert until correct seat width has been obtained.

Notes:

- With new valves and properly reworked valve seats it may not be necessary to grind in valves.
- When finishing grinding in work, carefully remove all traces of grinding paste.

Checking valve guides

- Insert new valve into valve guide. Valve stem end must be flush with the valve guide. Because of different stem diameters only insert inlet valves into inlet valve guides and outlet valves into outlet valve guides.

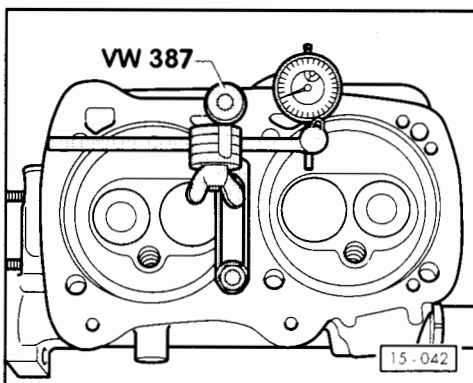

- ◀ - Measure rock
Wear limit: 1.2 mm

Removing and installing parts of the lubrication system

Notes:

- If, during engine repair work, large amounts of swarf and metal particles are noted in the engine oil caused by, for instance, seizing of main and connecting rod bearings, the oil passages must be thoroughly cleaned and the oil cooler renewed so as to avoid subsequent damage to the engine.
- The oil level in the engine must not exceed the max. marking, as this could cause damage to the catalytic converter!

Checking oil pressure ⇒ Page 17-7

Engine oil capacity ¹⁾

Without filter	4.0 ltr.
With filter	4.5 ltr.

¹⁾ Actual values
⇒ Exhaust gas and idling speed test

Engine oil specification

Use only oils in accordance with VW Standard 500 00 or 501 01. Use multi-grade oils according to API-SF or SG only in exceptional circumstances.

17-1

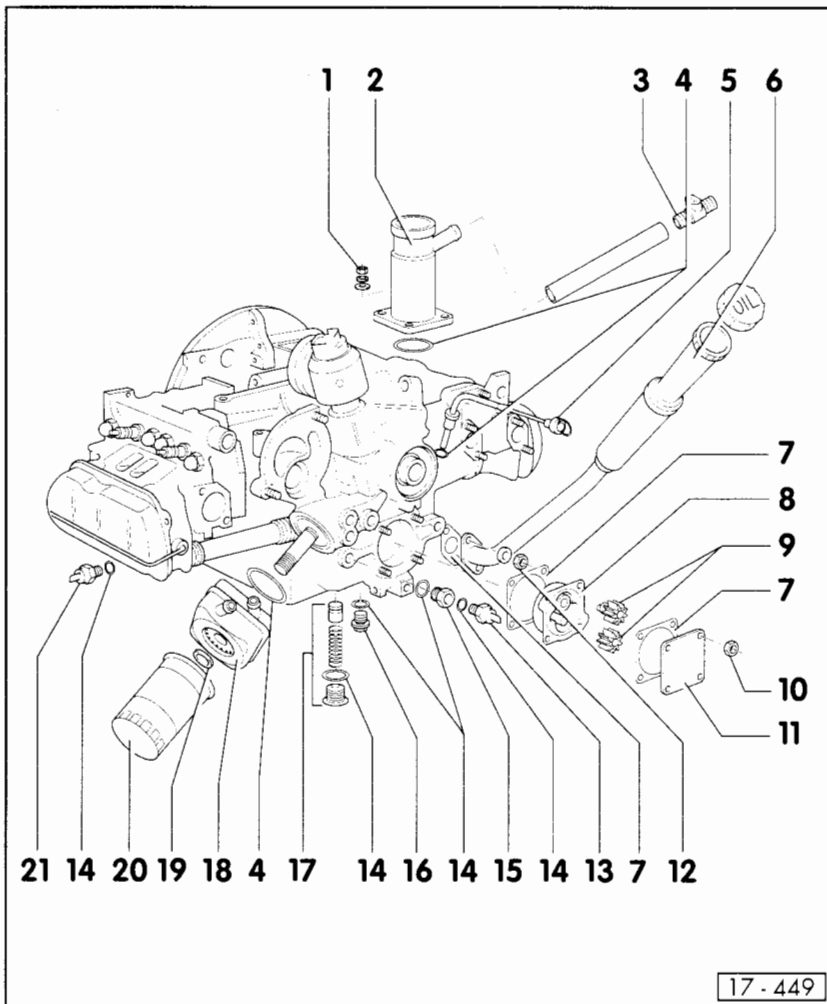

Note:

All components shown in the illustration can be removed and installed with the engine in situ.

- 1 – 8 Nm
- 2 – Crankcase breather
- 3 – Heater pipe (N79)
 - Arrow points towards intake hose
 - Checking ⇒ Fig. 1
- 4 – O-ring
 - Renew
- 5 – Oil dipstick
 - Capacity difference min...max. 1.0 ltr
 - Oil level must not exceed the max. marking!
- 6 – Oil filler neck
 - Pull out extension when topping up with oil

17-2

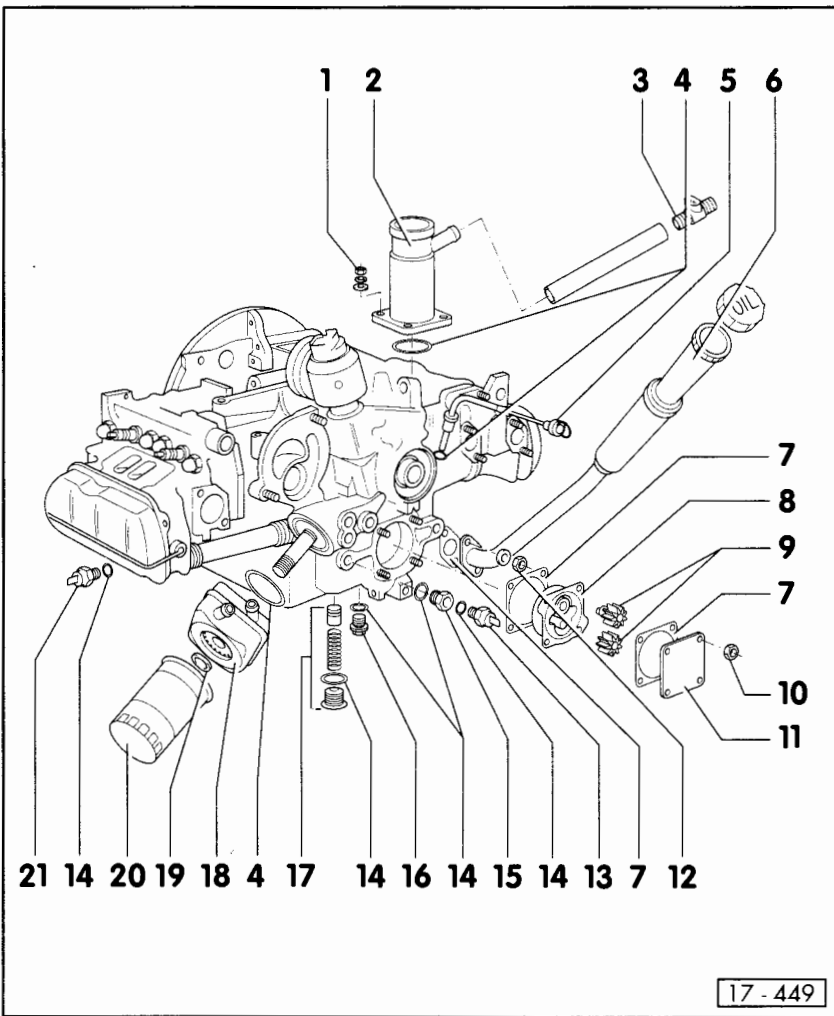

- 7 – Gasket
 - Renew
- 8 – Oil pump housing
 - Check for wear
 - Removing ⇒ Fig. 2
- 9 – Oil pump gears
 - Check for axial clearance ⇒ Fig. 3
- 10 – Sealing nut, 25 Nm
 - Renew
 - Sealing ring faces inwards
- 11 – Oil pump cover
 - Surface grind if scored
- 12 – 20 Nm

17-3

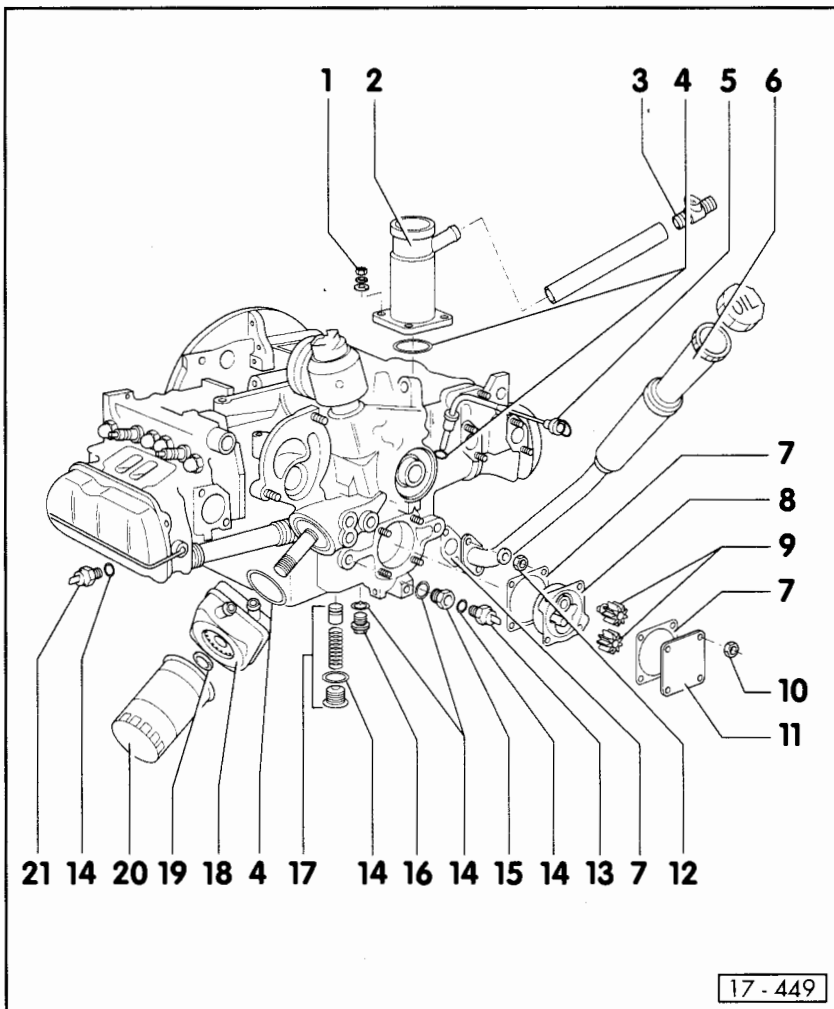

- 13 – 0.9 bar oil pressure switch, (F1), 25 Nm
 - Brown wire from switch to yellow wire of plug connector
 - To remove, push silencer cover plate back
 - Checking ⇒ Page 17-7
- 14 – Sealing ring
 - Renew if damaged
- 15 – 30 Nm
- 16 – Oil drain plug, 25 Nm
- 17 – Pressure relief valve, 20 Nm
 - Check for wear and freedom of movement

17-4

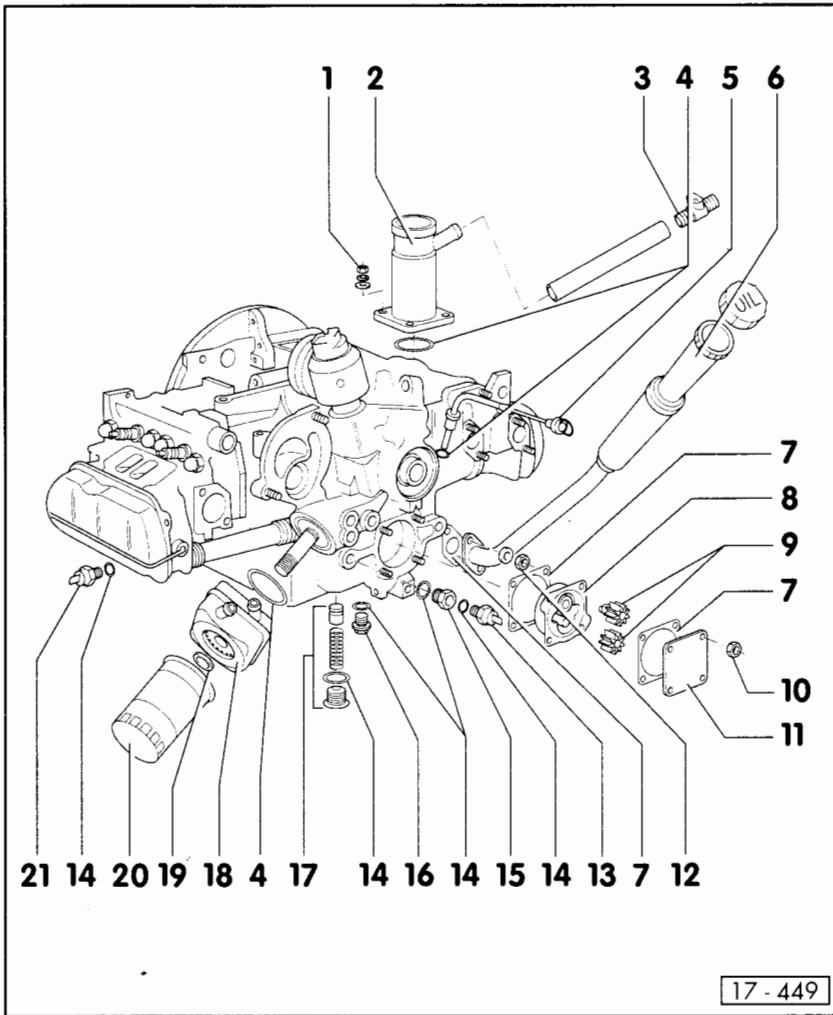

18 – Oil cooler

- Coat contact surfaces to flange outside the sealing ring with AMV 188 101 02
- Check for clearance to surrounding components
- Note instructions ⇒ Page 17-1

19 – 25 Nm

20 – Oil filter

- Loosen with strap wrench
- Tighten by hand
- Note installation instructions on oil filter

21 – 0.3 bar oil pressure switch (F22), 30 Nm

- Checking ⇒ Page 17-7

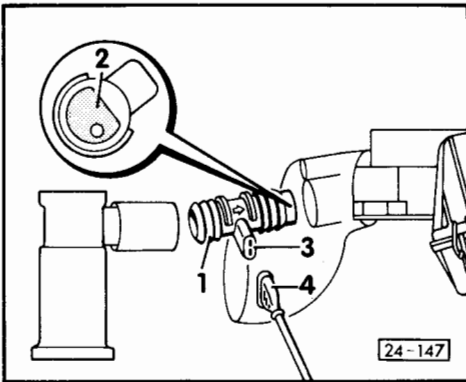

◀ **Fig. 1 Checking heater pipe for crankcase breather**

- 1 – Heater pipe (N79)
- 2 – Connection plate with 5.5 mm Ø drilling
- 3 – Resistance 4...17 Ohm at approx. 25°C
- 4 – approx. battery voltage (ignition switched on).

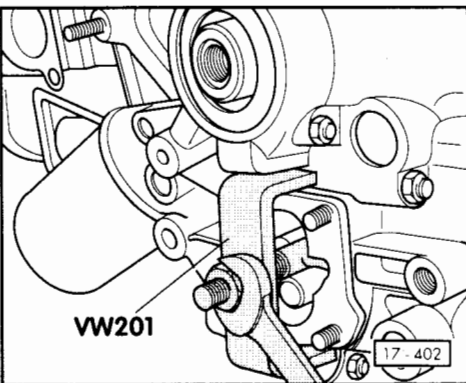

◀ **Fig. 2 Removing oil pump housing**

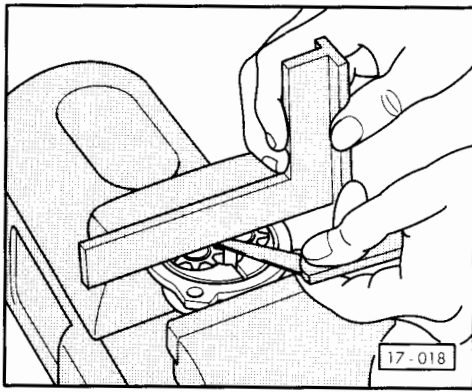

◀ Fig. 3 Oil pump – checking axial clearance

Wear limit: 0.10 mm

Checking oil pressure and oil pressure switch

(Optical and acoustic oil pressure indication)

Notes:

- *Functional check and servicing of the optical and acoustic oil pressure indication: ⇒ Circuit diagrams, Fault-Finding electric system and installation locations.*
- *Vehicles manufactured ▶ 07.85 are fitted only with a 0.3 bar oil pressure switch (without acoustic oil pressure indication).*

17-7

0.9 bar oil pressure switch (F1)

(Switch on the left next to oil pump)

- Remove exhaust system cover plate securing nut (under oil pump).
- Using a screwdriver, push the cover plate back and remove 0.9 bar oil pressure switch.
- ◀ – Screw oil pressure switch into the test appliance and connect blue wire –1–.
- Screw test appliance into crankcase in place of oil pressure switch.
- Connect test lamp V.A.G 1527-2 to wire –1– and alternator positive (+).
- Connect brown wire –3– to earth (–).
- Start engine and slowly increase engine speed . At 0.75...1.05 bar pressure the test lamp must light up, otherwise renew oil pressure switch.

Notes:

- *If necessary, check switching point of oil pressure switch at starter speed.*
- *The tester V.A.G 1342 remains connected for the 0.3 bar oil pressure switch test and for the oil pressure test at 2000 rpm.*

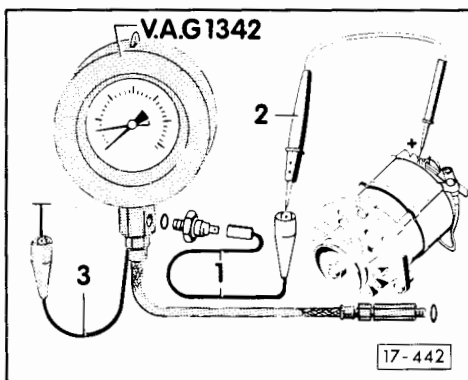

17-8

0.3 bar oil pressure switch (F22)
 (Switch on the left between the push rod tubes)

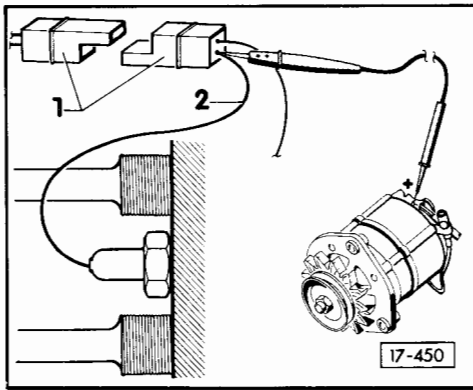

- ◀ - Disconnect plug connector -1-.
- Connect test lamp V.A.G 1527-2 to wire -2- to 0.3 bar oil pressure switch and to alternator positive (+).
The test lamp must light up.
- Start engine and slowly increase engine speed .
At 0.15 ... 0.45 bar pressure the test lamp must go out, otherwise renew oil pressure switch.
- Further increase engine speed.
At 2000 rpm and 80°C oil temperature the oil pressure should be at least 2.0 bar.

Removing and installing parts of the cooling system

Notes:

- All cooling system components can be removed and installed with the engine in situ.
- When the engine is hot the cooling system is pressurized. Before carrying out any work depressurize the system.
- Hose connections are secured either with spring type clips or screw type clamps. For repair purposes spring type clips can be replaced with screw type clamps.
- Secure all hose connections with hose clips so that even spring type clips can be removed with pliers with the engine installed.
- It is recommended to use standard type pliers such as Hazet 798-5 when assembling spring type clips.
- Check the cooling system for leaks using V.A.G 1274 and 1274/1A.

19-1

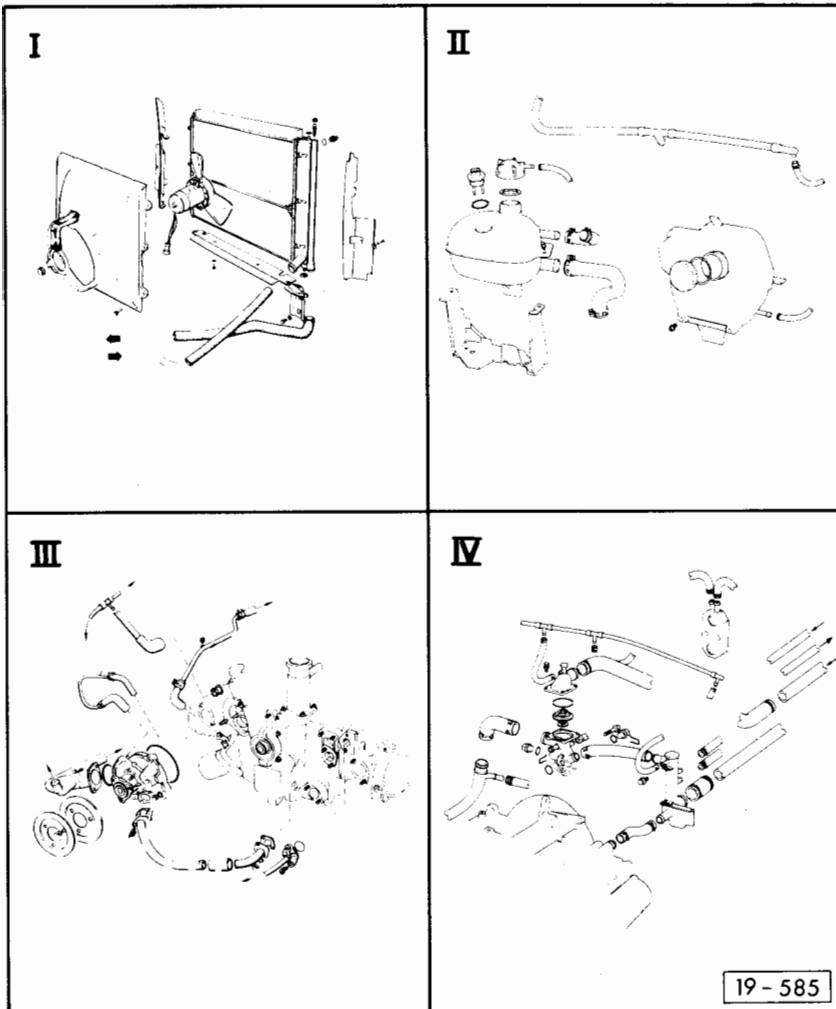

Draining and refilling with coolant
⇒ Page 19-12

Coolant mixture ratio ⇒ Page 19-12,
Draining and refilling with coolant

Part I ⇒ Page 19-3

Part II ⇒ Page 19-6

Part III ⇒ Page 19-8

Part IV ⇒ Page 19-9

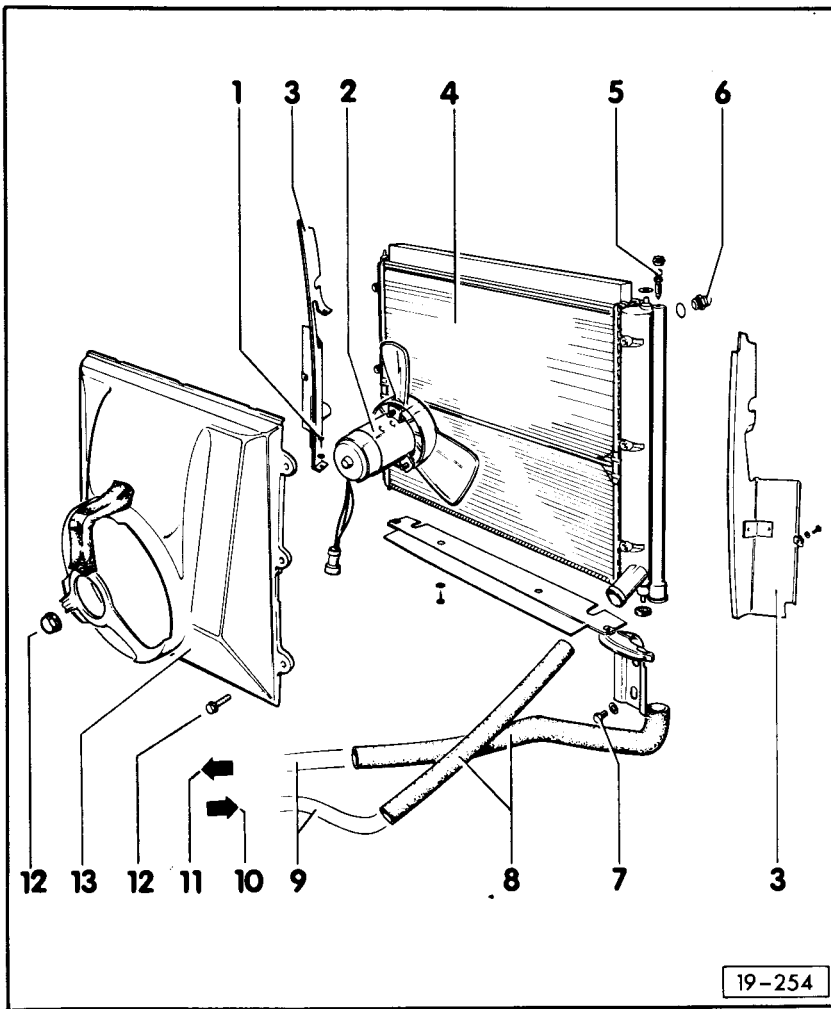

Part I

Note:

Always renew gaskets and sealing rings.

- 1 – Lower bolt**
 - Remove on both sides before lowering the radiator into position
- 2 – Radiator fan (V7)**
 - Can be removed and installed without draining the coolant after radiator has been lowered
- 3 – Air deflector**
- 4 – Radiator**
 - Remove spare wheel bracket and radiator grill before lowering the radiator
 - After changing the radiator renew all coolant

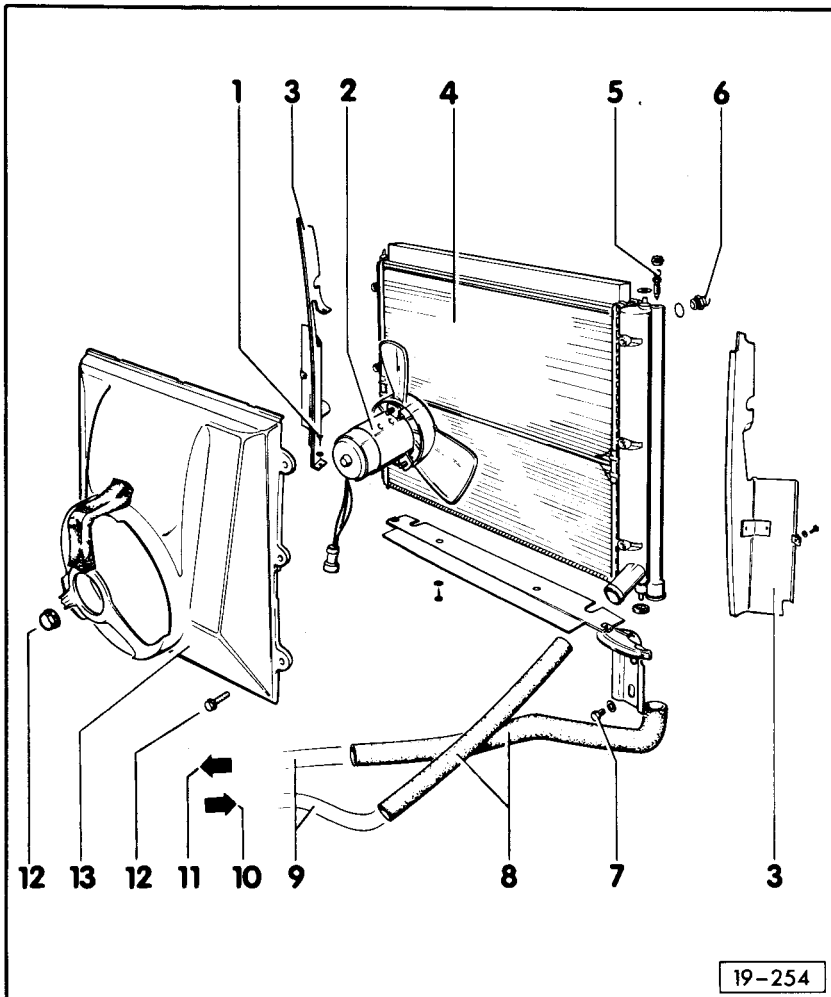

- 5 – Bleeder screw**
 - Open when refilling with coolant
⇒ Page 19-12, Draining and refilling with coolant
- 6 – Thermostatic switch (F18), 25 Nm**
 - For electric fan
 - 2-stage switch
 - Switching temperatures:

1st stage	On	89 ...	94°C
	Off		81°C
2nd stage	On	95 ...	100°C
	Off		87°C
 - To remove and install – remove radiator grill and move left-hand cardboard air deflector to side
- 7 – 15 Nm**
- 8 – Coolant hoses**
- 9 – Coolant pipes**

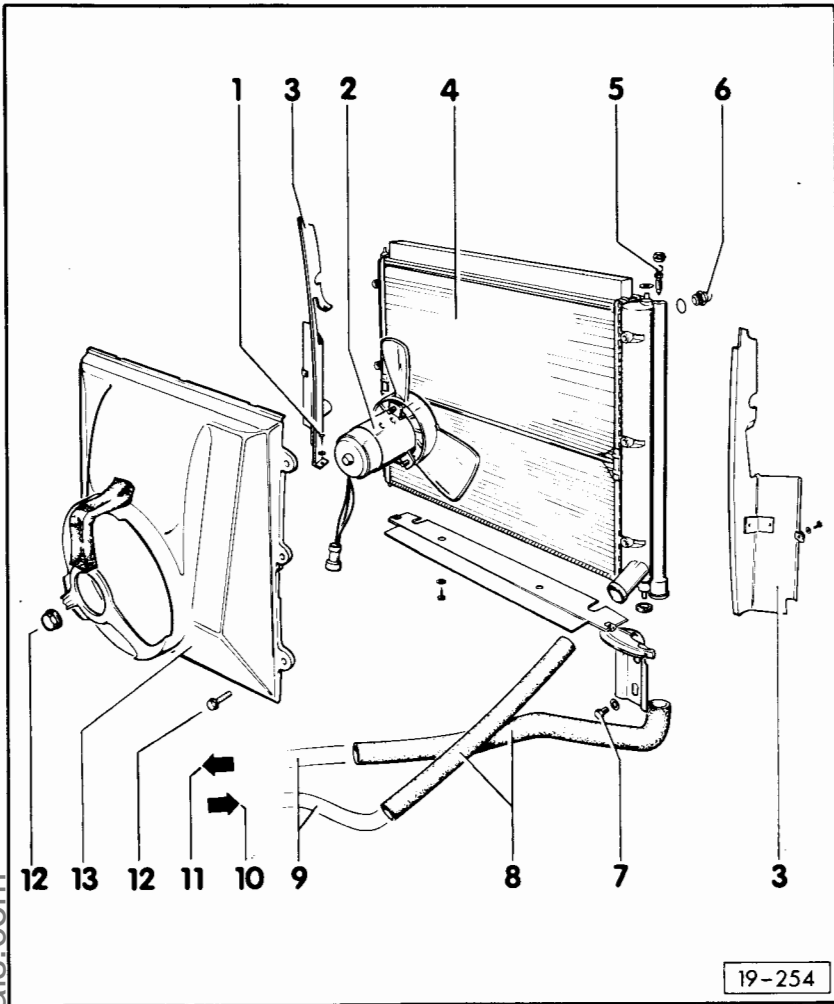

19-254

- 10 – From cylinder head
 - ⇒ Page 19-11, item 15
- 11 – To thermostat
 - ⇒ Page 19-10, item 14
- 12 – 10 Nm
- 13 – Radiator scoop

19-5

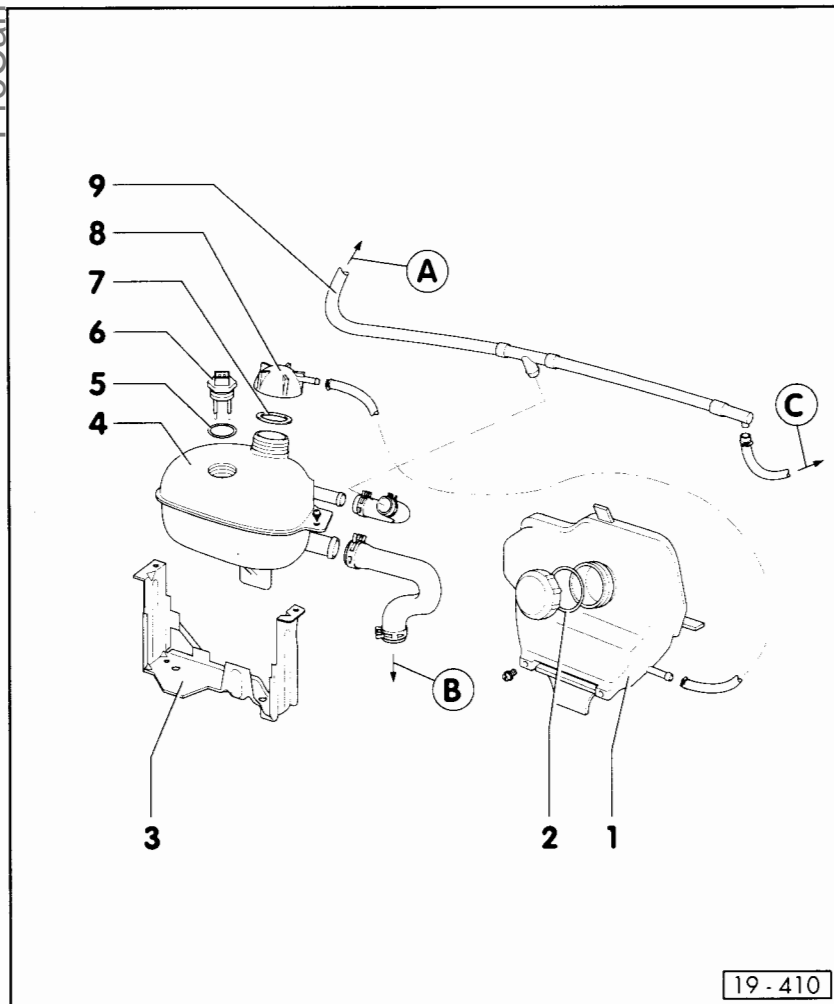

19-410

Part II

A, B, C ⇒ Page 19-8

- 1 – Top-up reservoir
 - Note min. and max. markings
 - Filling with coolant ⇒ Page 19-12
- 2 – Sealing ring
 - Renew if damaged
- 3 – Bracket
- 4 – Expansion tank
 - Filling with coolant ⇒ Page 19-12
- 5 – O-ring
 - Renew
- 6 – Low coolant level indicator switch (F66)

19-6

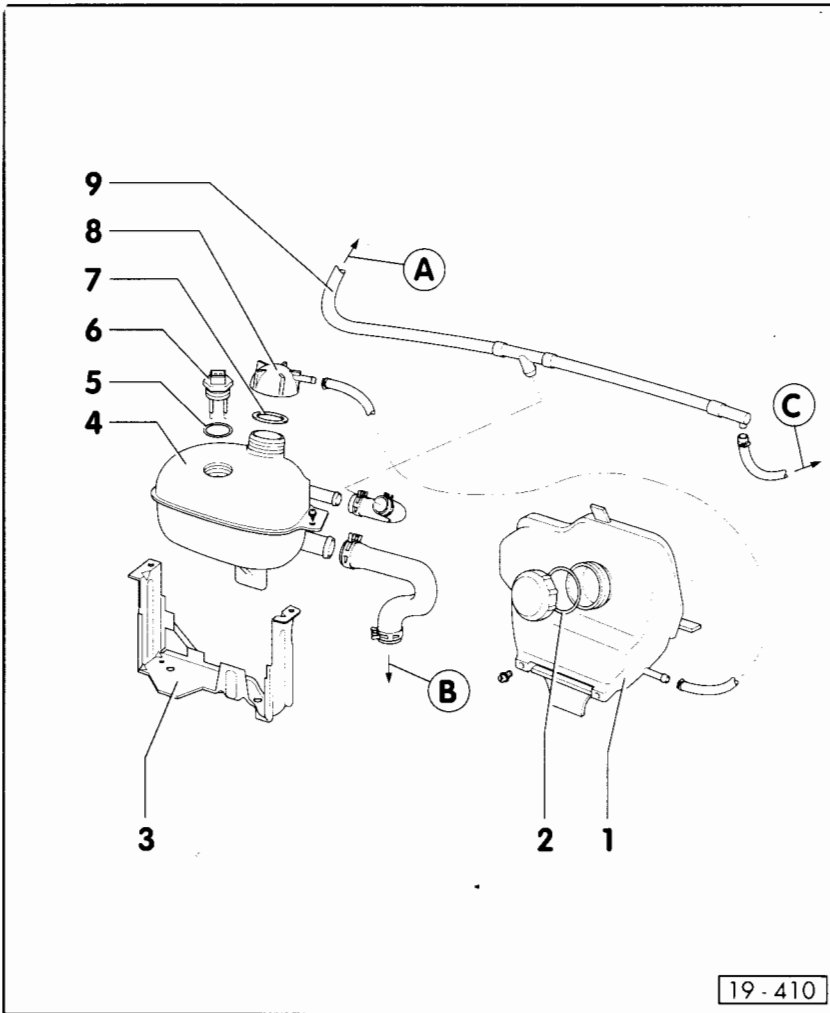

- 7 – Sealing ring
 - Renew if damaged
- 8 – Sealing cap
 - Check with V.A.G 1274 and 1274/1A
 - Test pressure: 0.9...1.5 bar
- 9 – Ring main

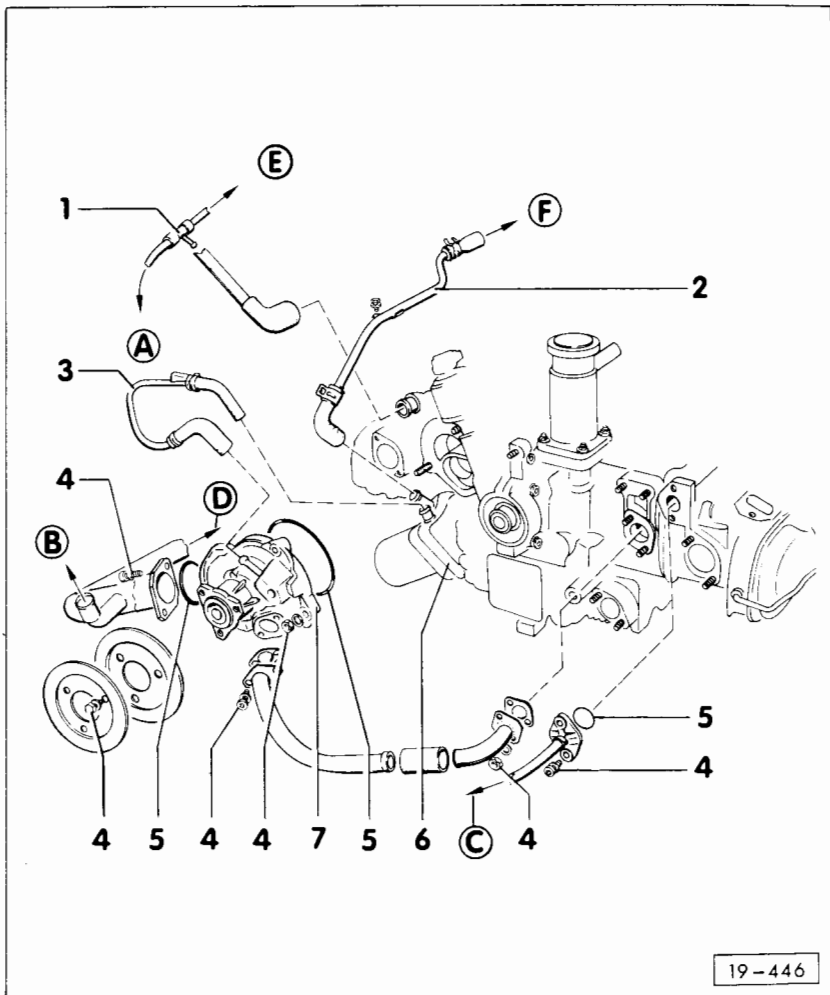

Part III

Note:

Always renew gaskets and sealing rings.

A, B, C ⇒ Page 19-6
D, E, F ⇒ Page 19-9

- 1 – Ring main
- 2 – Pipe
 - For oil cooler
- 3 – Pipe
 - For oil cooler
- 4 – 20 Nm
- 5 – O-ring
 - Renew
- 6 – Oil cooler
- 7 – Coolant pump
 - Check shaft for freedom of movement

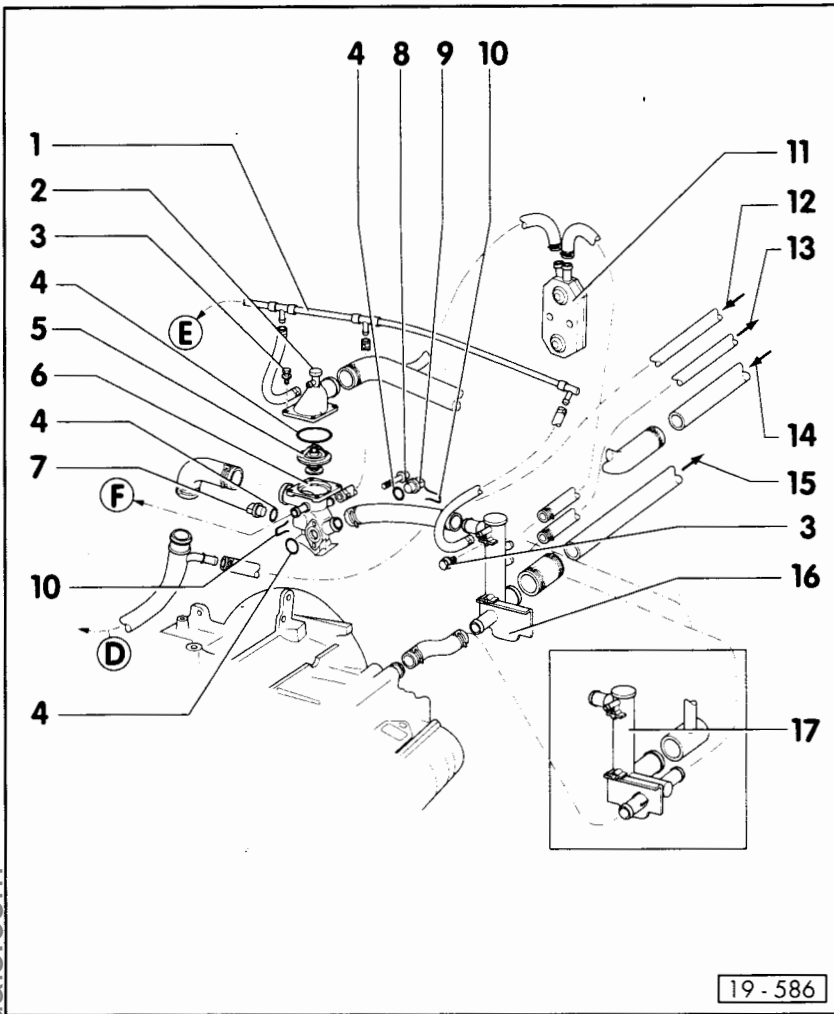

Part IV

D, E, F ⇒ Page 19-8

- 1 – Ring main
- 2 – Bleed valve
 - Open when refilling with coolant
 - ⇒ Page 19-12, Draining and refilling with coolant
- 3 – 10 Nm
- 4 – O-ring
 - Renew
- 5 – Thermostat
 - Checking: Heat thermostat in water
 - Opens at approx. 85°C
 - Closes at approx. 105°C
 - Opening stroke at least 8 mm
- 6 – Thermostat housing

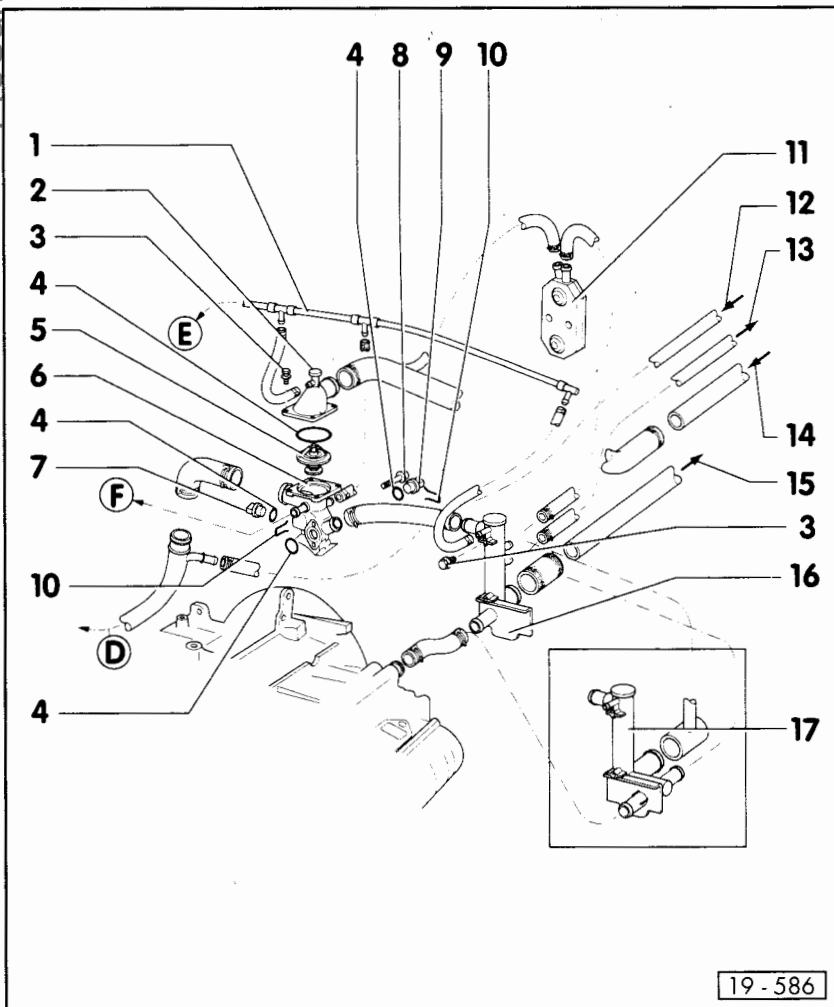

- 7 – Coolant temperature sender (G18)
 - For injection and ignition systems
 - Checking ⇒ Repair Group 01
- 8 – 20 Nm
- 9 – Coolant temperature gauge sender (G2)
- 10 – Retaining spring
- 11 – ATF cooler
 - For automatic gearbox
- 12 – From heat exchanger
- 13 – To heat exchanger
- 14 – From radiator
 - ⇒ Page 19-5, item 11

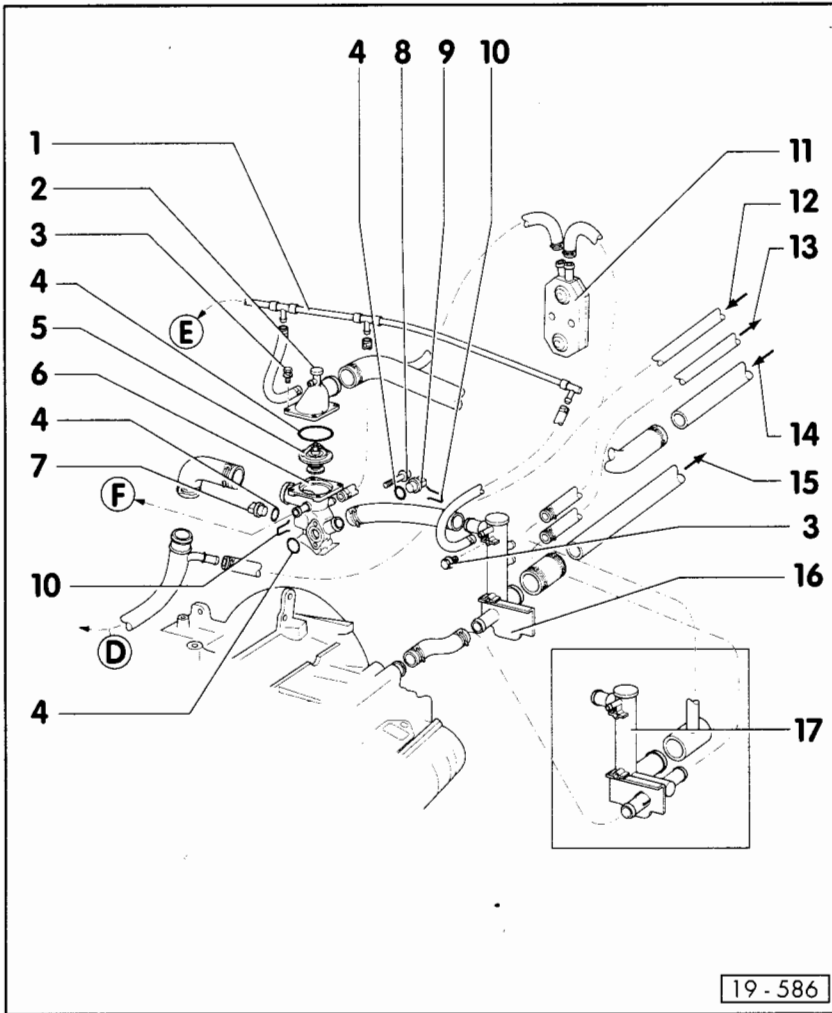

15 – To radiator
 • ⇒ Page 19-5, item 10

16 – Distributor unit
 • ▶ 10.86

17 – Distributor unit
 • 11.86 ▶

Draining and refilling coolant system

Draining

Engine repairs

- ◀ – Using hose clamp 3093 clamp hose -1- from radiator to thermostat housing.
- Using hose clamp 3094 clamp hose -2- from heat exchanger (heater) to coolant pipe.

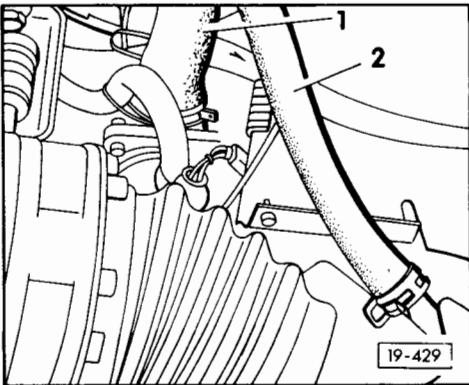

- ◀ – Loosen hose clamp -1- and clamp hose -2- from radiator to distributor unit with hose clamp 3093.
- Using hose clamp 3094 clamp hose -3- from heat exchanger (heater) to distributor unit.

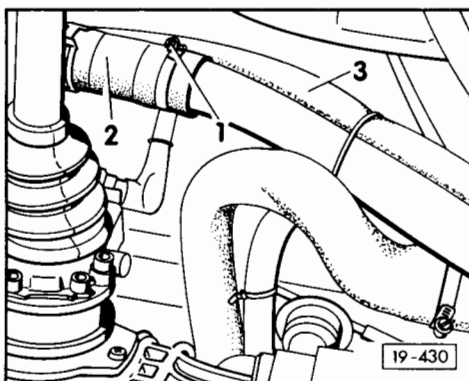

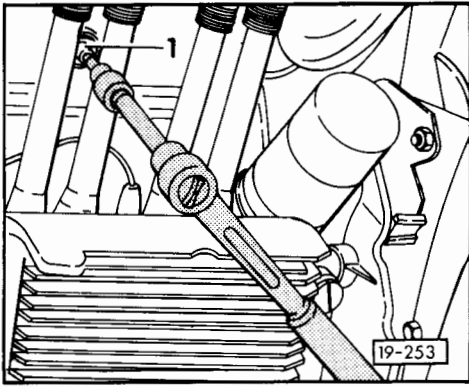

- ◀ – Drain coolant through drain plugs –1– on cylinder heads.
- Open expansion tank cap.

Repairs to radiator

- Seal coolant hoses with hose clamp 3093 before removing hoses.

Refilling

Notes:

- The cooling system is filled with a mixture of water and G 11 frost and anti-corrosion protection agent which remains in the system all the year round. G 11 and coolant additives marked with the warning "in accordance with TL VW 774 B" prevent frost and corrosion damage and scales as well as raising the boiling point of the coolant. For these reasons the cooling system must be filled with the frost and anti-corrosion mixture all the year round. Due to the higher boiling point the coolant is an aid to operating efficiency when the engine is operating under full load, particularly in tropical climates.
- If the radiator, heat exchanger, cylinder heads or cylinder head gaskets are changed, the coolant must be renewed.

Recommended coolant mixtures

Frost protection up to	Anti-freeze part ¹⁾	G 11	Water
-25°C	40%	7.0 ltr.	10.5 ltr.
-35°C	50%	8.75 ltr.	8.75 ltr.

¹⁾ The proportion of anti-freeze must not exceed 60%, as frost protection and cooling effects are reduced with greater proportions of anti-freeze.

- Set heater control to max.
 - Remove radiator grill.
 - ◀ – Loosen bleed screw on radiator approx. 3 turns.
 - ◀ – Open bleed screw in engine compartment.
- Position A = open
Position B = closed

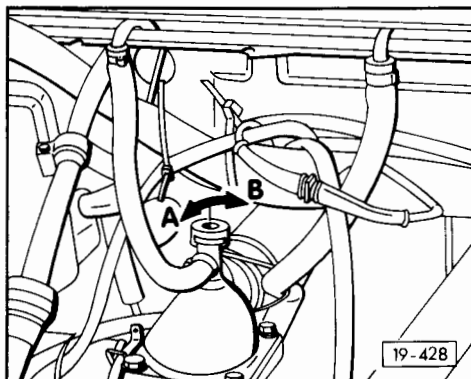
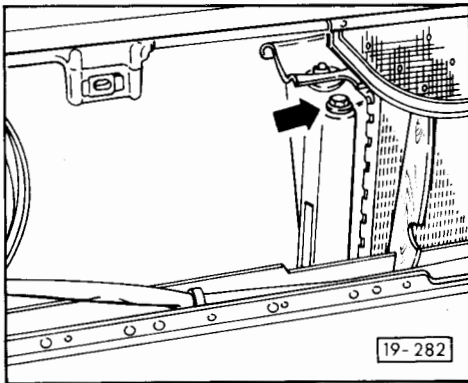

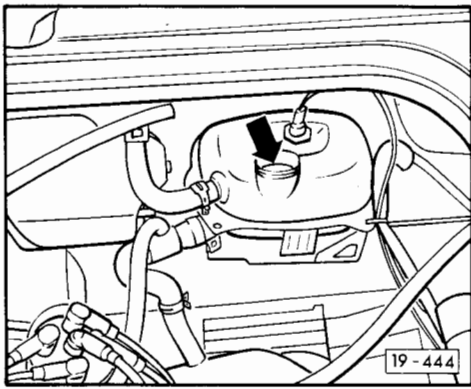

- ◀ – Fill expansion tank to the brim (approx. 8.0 ltr).
- Start engine.
- With approx. 2000 rpm top up until coolant issues from the radiator bleed screw, then tighten screw.
- Fill expansion tank to brim and close filler cap.
- Switch off ignition.
- Raise vehicle approx. 40 cm at front under cross member with trolley jack and wooden underlay or with a two pillar 6 t hoist V.A.G. 1372.
- Re-start engine.
- At engine speed of approx. 2000 rpm open bleed screws on radiator and expansion tank.
- Close bleed screw on radiator when coolant issues out.
- Add coolant if necessary and close expansion tank filler cap.
- Switch off engine.

19-15

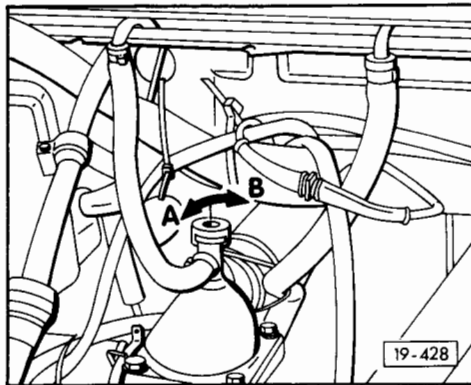

- ◀ – Close bleed valve in engine compartment.
- Position A = open
Position B = closed.

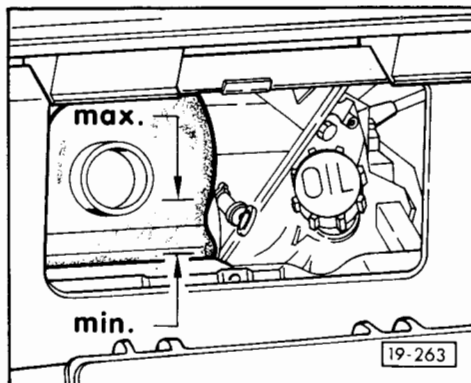

- ◀ – Fill top-up reservoir up to brim. With the engine cold the coolant level must be between the min. and max. marking.

19-16

Removing and installing parts of the fuel system

Safety precaution ⇒ Page 20-9.

Rules for cleanliness ⇒ Page 20-10.

Checking the fuel system for leaks (vehicles with rear wheel drive) ⇒ Page 20-16.

Notes:

- Hose connections are secured with either screw or clip type clamps.
- Always renew clip type clamps with screw type clamps.

20-1

Vehicles with rear wheel drive

Synchro ⇒ Page 20-6

1 - Expansion tank

2 - 15 Nm

3 - O-ring

- Renew
- Coat with graphite powder before installing

4 - Breather pipes

5 - Fuel gauge sender

- Removing and installing ⇒ Page 20-15
- Installation position ⇒ Page 20-15, Removing and installing fuel gauge sender

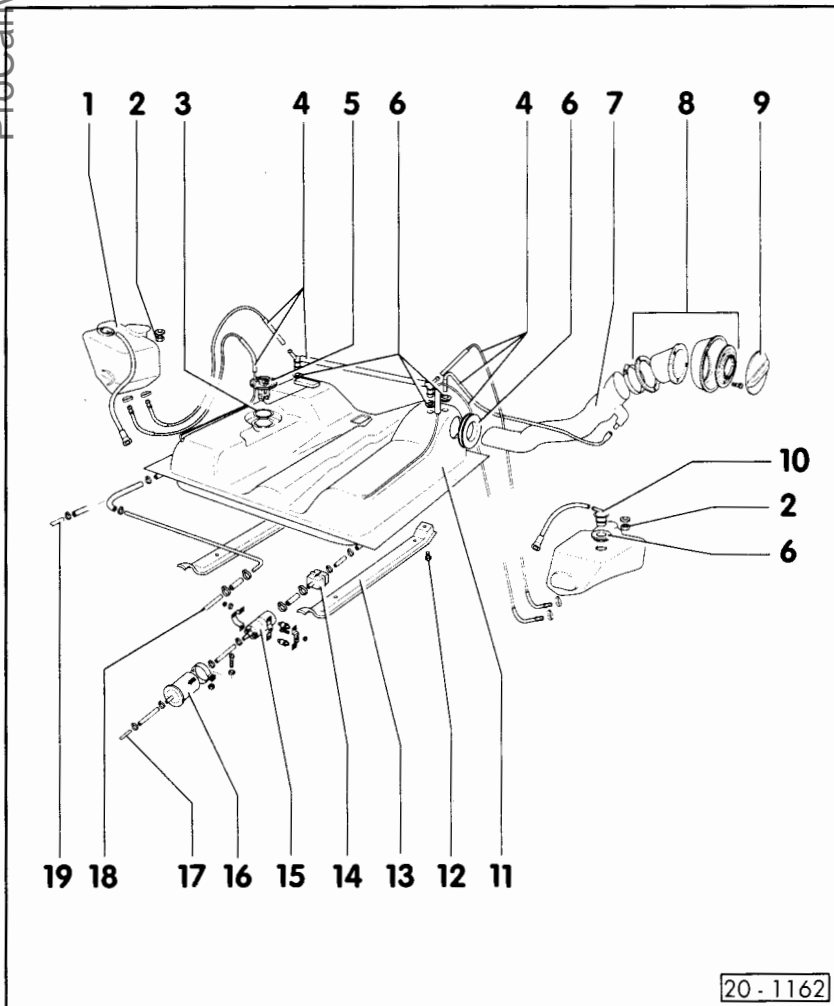

20-1162

20-2

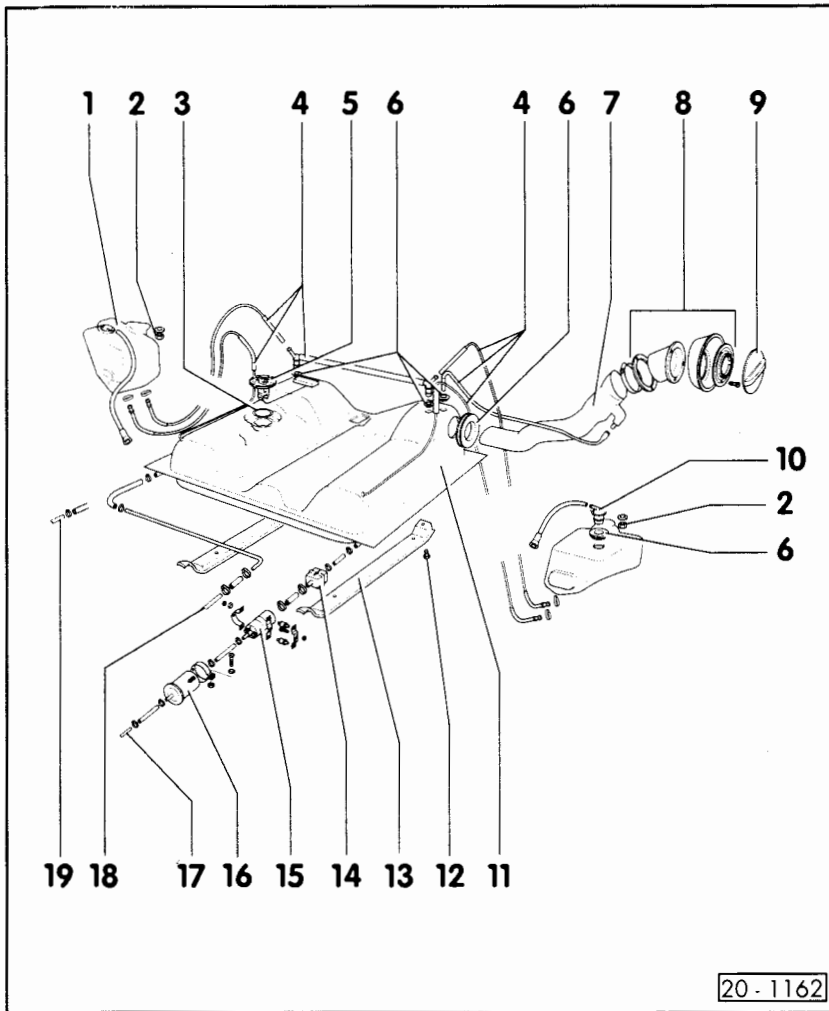

- 6 – Seal
 - Renew
- 7 – Filler pipe
 - 08.87 ▶ with ball retainer cage on vehicles with catalytic converter
- 8 – Filler elbow
 - Removing: turn to unlock from side panel
- 9 – Filler cap
 - Renew seal if damaged
- 10 – Float valve
 - Checking: when turned 180° (connection downwards) valve must be closed
- 11 – Fuel tank
 - Removing ⇒ Page 20–11
 - Checking for leaks ⇒ Page 20–16, checking fuel system for leaks

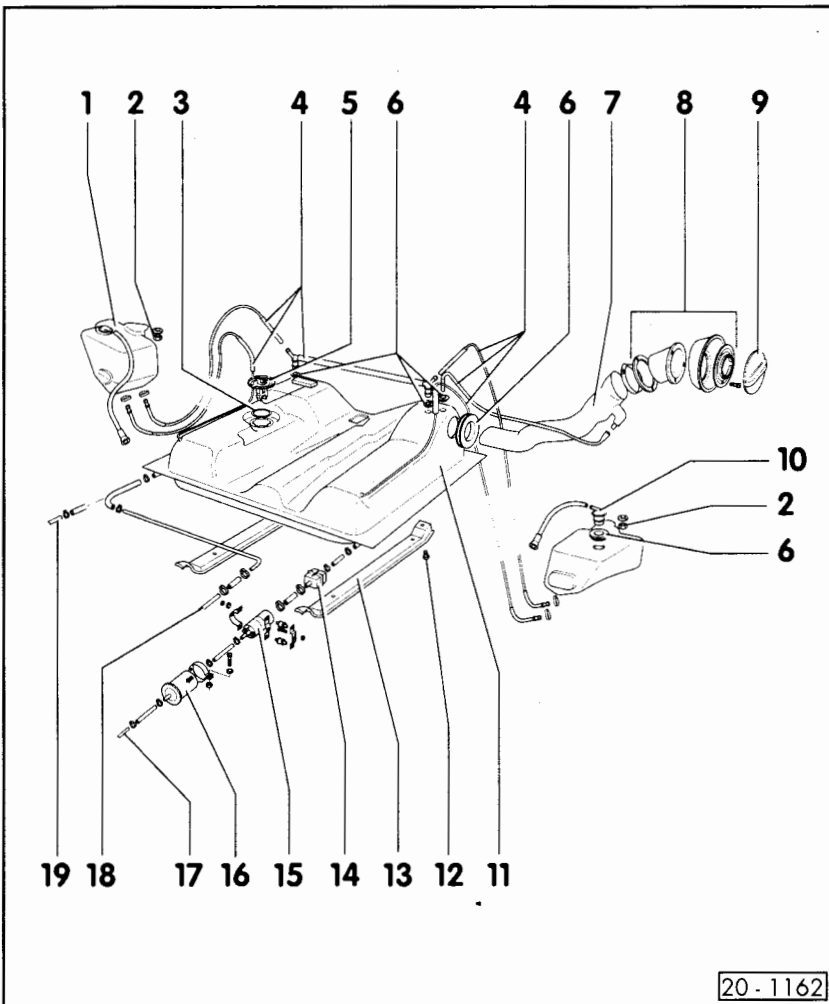

- 12 – 25 Nm
- 13 – Protective rail
- 14 – Fuel filter
 - Only fitted when fuel filter is not incorporated in pump
 - If leaking replace with hose
- 15 – Fuel pump (G6)
 - Checking ⇒ Page 20–17
- 16 – Fuel filter
 - Installation position: Arrow points in direction of flow to engine
- 17 – Pre-feed pipe
 - To branch pipe
- 18 – Return pipe
 - 07.86 ▶
 - From fuel pressure controller

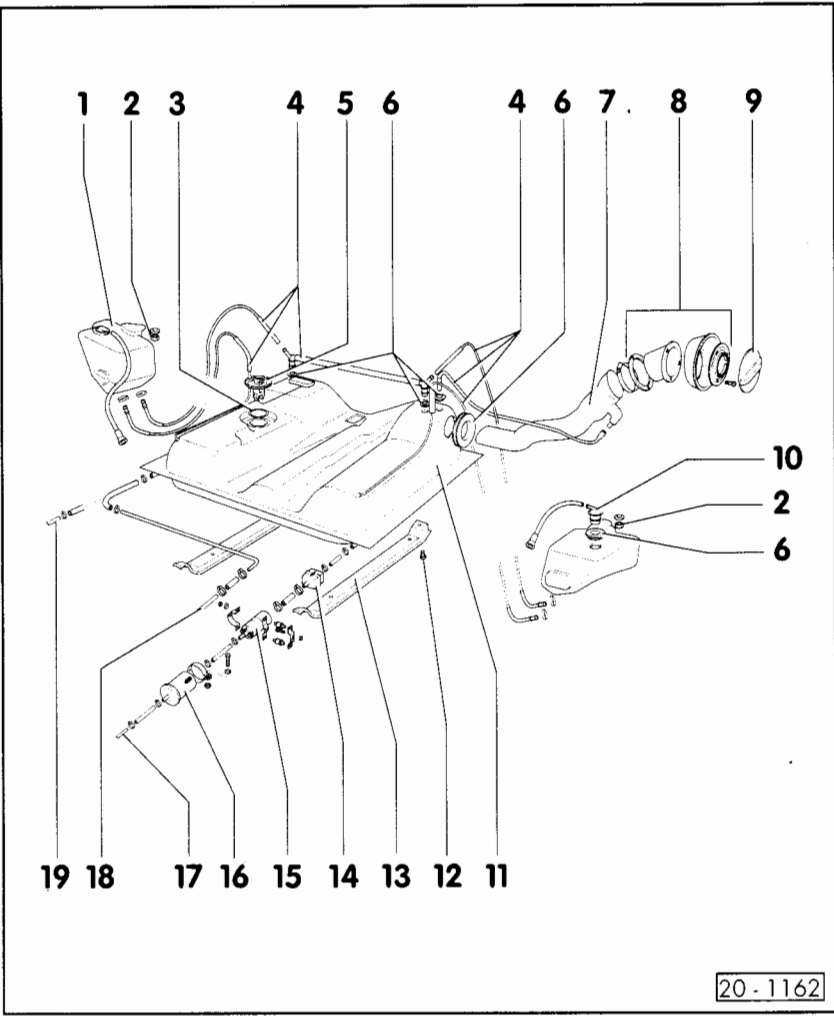

20-1162

- 19 – Return pipe
 - ▶ 06.86
 - From fuel pressure controller

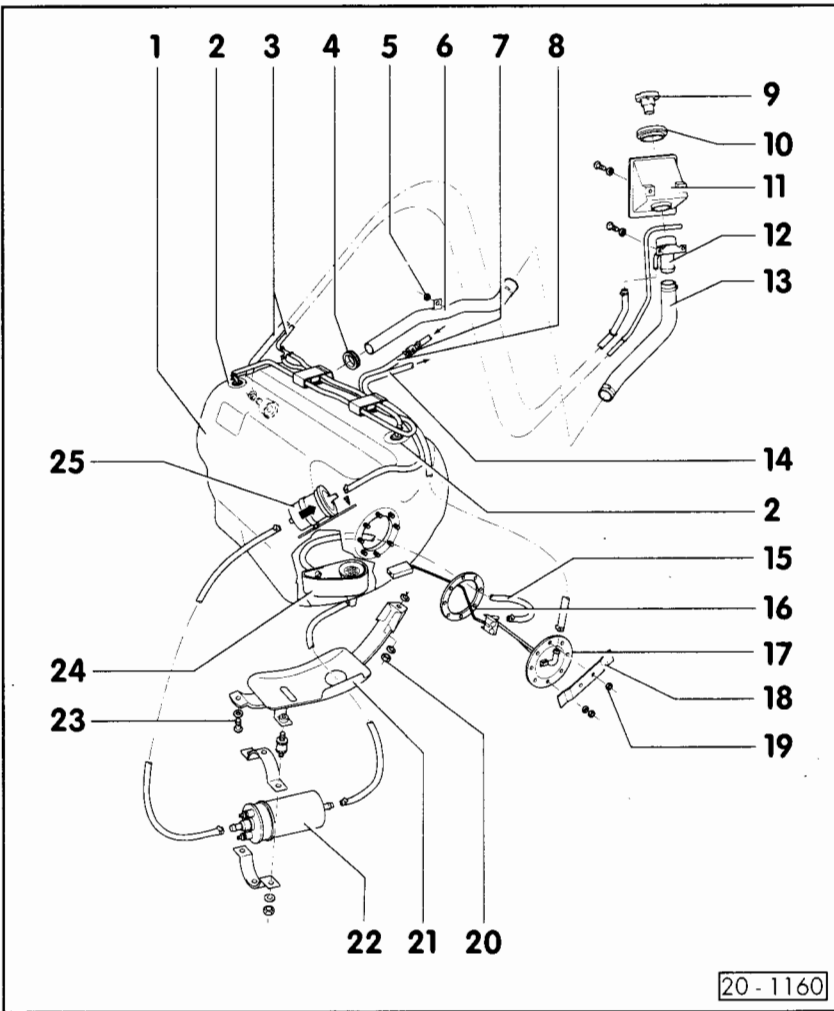

20-1160

Synchro

- 1 – Fuel tank
 - Removing ⇒ Page 20-11
- 2 – Float valve
 - Checking: when turned 180° (connection downwards) valve must be closed
- 3 – Venting and breather pipes
- 4 – Sealing ring
 - Renew if damaged
- 5 – 10 Nm
- 6 – Filler pipe
- 7 – Non-return valve
 - Installation position: Arrow points in direction of flow (to fuel gauge sender)

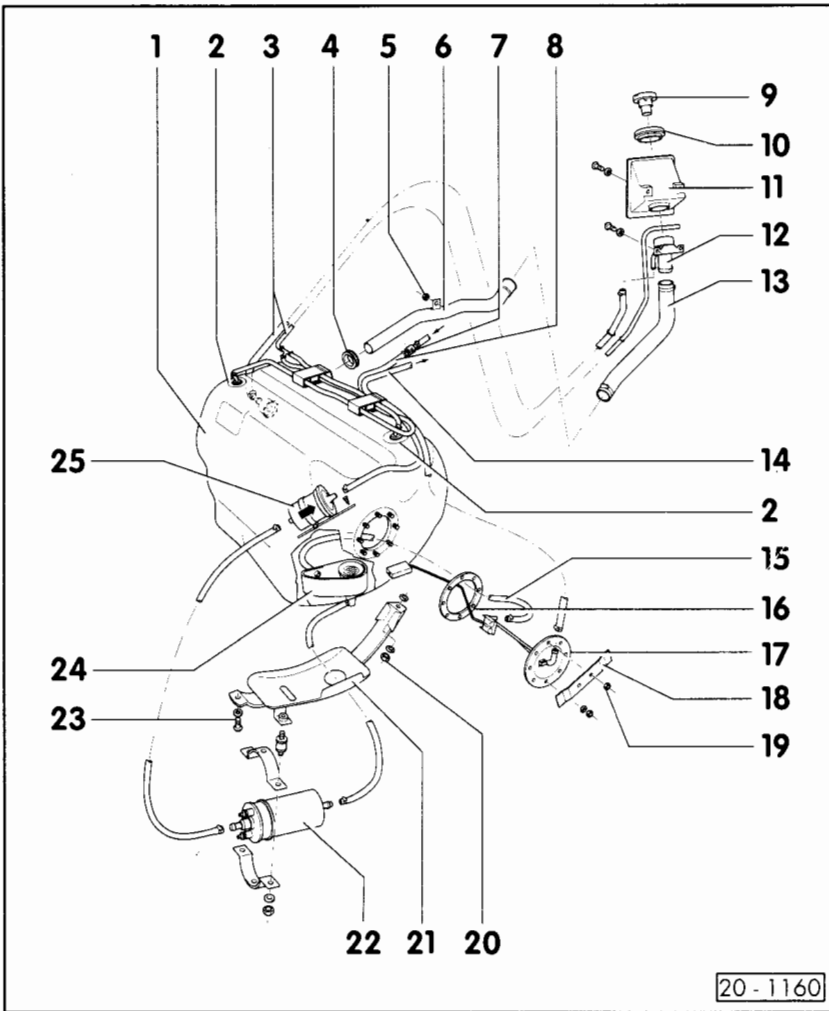

- 8 – Return flow pipe
 - From engine to sender
- 9 – Cap
 - Renew seal if damaged
- 10 – Sealing ring
- 11 – Bracket
- 12 – Filler elbow
- 13 – Hose
- 14 – Pre-feed pipe
 - From fuel filter to engine ring main
- 15 – Return flow pipe
 - From sender to fuel reservoir in fuel tank
- 16 – Gasket
 - Renew

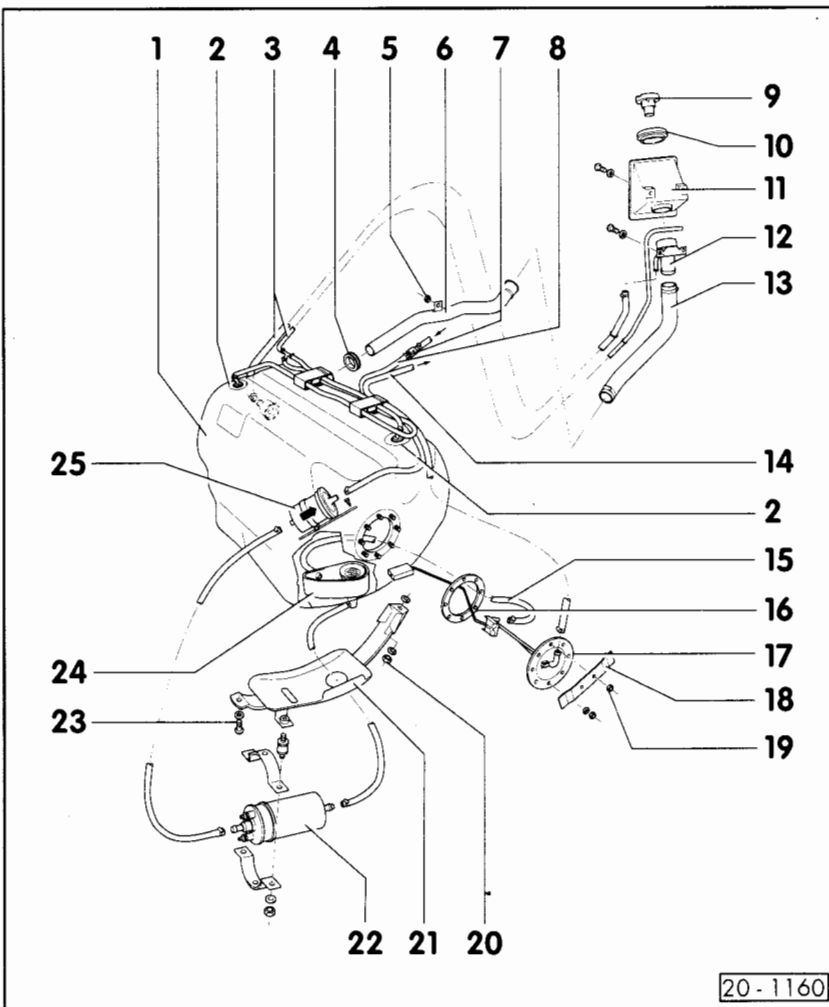

- 17 – Fuel gauge sender
 - Removing and installing ⇒ Page 20-15
- 18 – Fuel pipe bracket
- 19 – 5 Nm
- 20 – 20 Nm
- 21 – Support bracket
- 22 – Fuel pump (G6)
 - Checking ⇒ Page 20-17
- 23 – 20 Nm
- 24 – Fuel reservoir with wire mesh filter
- 25 – Fuel filter
 - Installation position: Arrow points in direction of flow (to engine)

Safety precautions

When removing and installing the fuel gauge sender from and to a filled or partly filled fuel tank the following must be observed:

- The extraction pipe of an exhaust gas extraction system must be positioned in the vicinity of the assembly aperture of the fuel tank before work can commence in order to extract released fuel vapours which will escape as soon as the cap is opened.
If no such exhaust gas extraction system is available, a radial fan (with the motor outside the air stream) with a delivery volume greater than 15 m³/h may be used.
- Avoid fuel contacting the skin! Wear fuel resistant gloves!

20-9

Rules for cleanliness

When working on the fuel system/injection system the following "5 Rules" for cleanliness must be strictly observed:

- Thoroughly clean all connections and their immediate vicinity before loosening the unions.
- Place removed parts on a clean surface and cover up. Do not use fluffy cloths!
- Carefully cover or seal opened or dismantled components if the repair work cannot be carried out immediately.
- Install only clean components:
Unpack replacement parts only immediately prior to installation.
Do not use parts which were stored unpacked (for instance in tool boxes etc.).
- When the fuel system is open:
Do not work with compressed air if this can be avoided.
Do not move the vehicle unless absolutely necessary.

20-10

Removing the fuel tank

Safety precautions ⇒ Page 20-9.

Rules for cleanliness ⇒ Page 20-10.

Vehicles with rear wheel drive

- With the ignition switched off, disconnect battery earthing strap.

Note:

If applicable, determine the radio anti-theft code before disconnecting the earthing strap from the battery.

- Drain fuel tank.
- ◀ - Remove filler pipe -1- by loosening clamp -2- on filler elbow and pulling out breather pipe -3-.
- ◀ - Remove breather pipes -1-, -2- and -3- on right side.

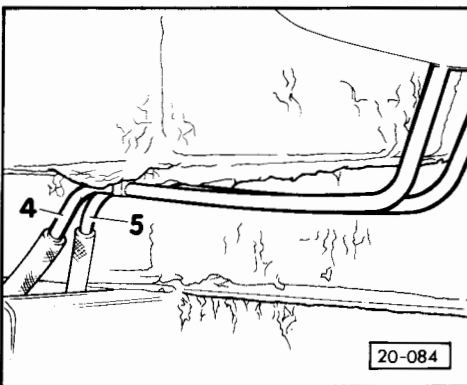
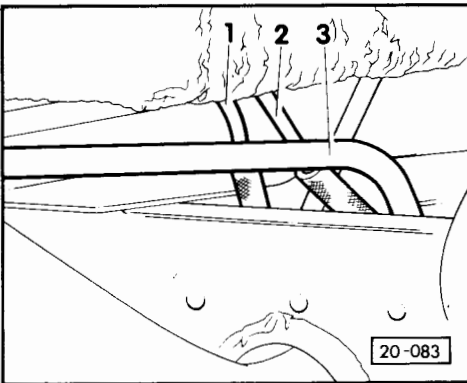
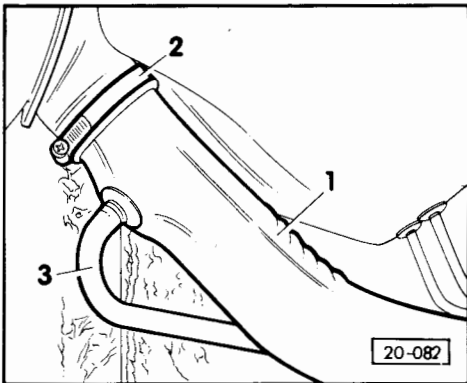

- ◀ - Pull off breather pipes -4- and -5- on left side.

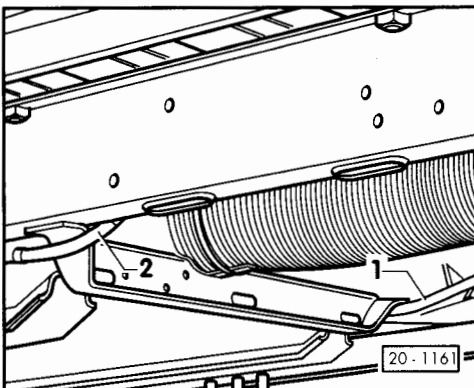

- ◀ - Pull off inlet pipe -1- and return flow pipe -2- from fuel tank.

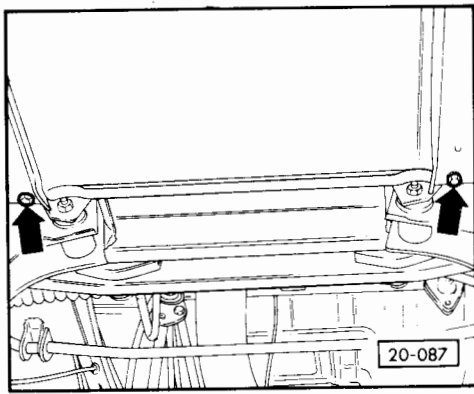

- ◄ – Unscrew protective rails from body –arrows– and remove from brackets.
- Lower fuel tank and disconnect electrical connection from fuel gauge sender.
- Remove fuel tank.
- After installing the fuel tank check fuel system for leaks ⇒ Page 20-16.

Synchro

Notes:

- *The fuel tank can be removed and installed after removing the manual gearbox.*
- *Removing and installing manual gearbox:
⇒ 5-speed manual gearbox 094; four-wheel drive and axle drive*
- With the ignition switched off, remove earthing strap from battery.

Note:

If applicable, determine the radio anti-theft code before disconnecting the earthing strap from the battery.

- Drain fuel tank.

20-13

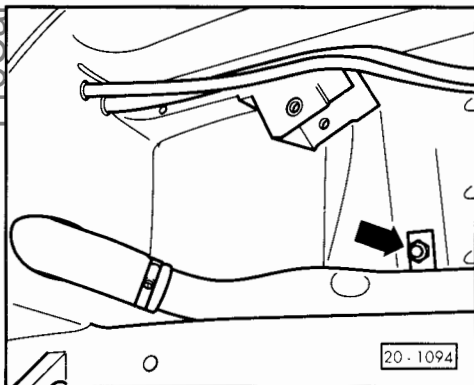

- ◄ – Remove rear right-hand shock absorber and unscrew attachment nut –arrow– for filler pipe.
- Remove filler pipe.
- Remove starter motor.
- Disconnect breather and fuel pipes.
- Disconnect electrical connection from fuel gauge sender.

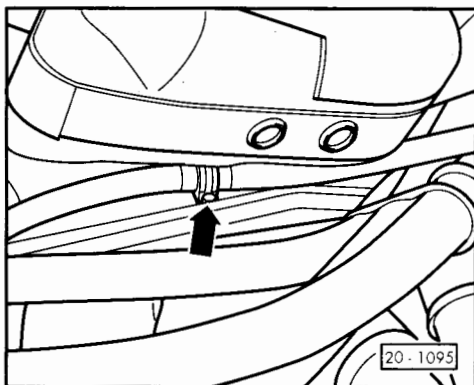

- ◄ – Remove retaining clamp for starter motor cable fro body.
- Remove retaining straps.
- Carefully press the starter motor cable, coolant pies and hoses to the side when taking out the fuel tank.

Note:

Do not damage the fuel tank non-return valve when installing the fuel tank.

20-14

Removing and installing fuel gauge sender

Vehicles with rear wheel drive

Removing the fuel tank ⇒ Page 20–11.

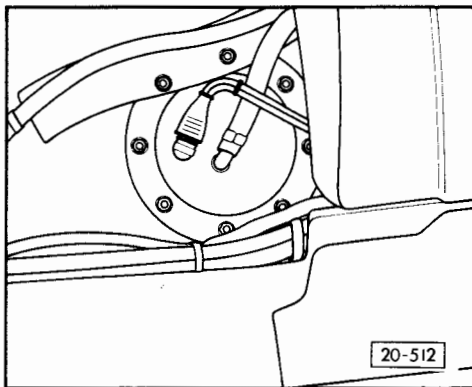
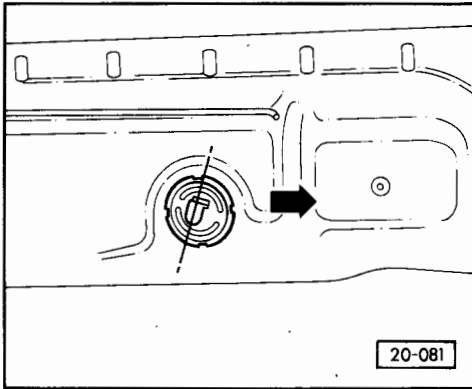

- ◀ – Remove and install sender with tool 2012A. Installation position: Electrical connection must align with dotted line (arrow points in direction of travel).

Synchro

With the ignition switched off, disconnect earthing strap from battery.

Note:

If applicable, determine the radio anti-theft code before disconnecting the earthing strap from the battery.

- Empty fuel tank until the fuel level is lower than the sender aperture.
- ◀ – Removing and installing the sender (behind rear left-hand wheel arch). Installation position: float valve arm vertically movable. when installing the float valve, ensure that the return flow pipe is guided into the fuel tank reservoir hole ⇒ Page 20–6, Fig. 20-1160.
- After installation of the sender fill the fuel tank to top and visually check for leaks.

20–15

Checking fuel system for leaks

(Vehicles with rear wheel drive)

After repair work on the fuel tank the fuel system should be checked for leaks as follows after the fuel tank has been installed:

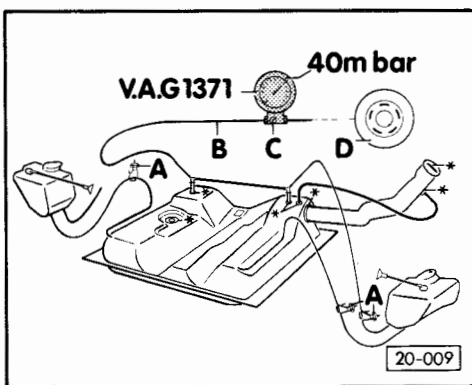

- ◀ – Seal breather hoses from fuel tank to expansion tanks with hose clamps –A–.
- Connect breather pipe –B– to pressure gauge V.A.G. 1371.
- Close valve –C– and connect pressure gauge with tyre valve –D–.
- Slowly open valve C until 40 mbar is indicated, then close valve.

There are no leaks in the fuel system if, after 5 minutes, at least 35 mbar are indicated.

- If the system is leaking, check the pipe connections and those points marked with an * with a soapy solution and seal as necessary.
- Correct type pressure.

20–16

Checking the fuel pump

- Battery voltage in order.
- Switch on ignition.
Fuel pump must be heard to run briefly for approx. 1 sec.

If the pump does not run:

- Switch off ignition and disconnect earthing strap from battery.

Note:

If applicable, determine the radio anti-theft code before disconnecting the earthing strap from the battery.

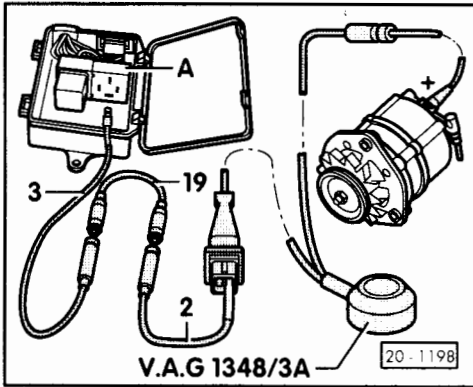

- ◀ – Pull off fuel pump relay from relay adaptor –A–.
- Connect remote V.A.G. 1348/3A and auxiliary cables 2, 3 and 19 from V.A.G. 1594 to terminal 87 of the relay adaptor –A–.
- Connect remote control clamp to positive connection (+) of alternator.
- Connect battery earthing strap.
- Operate remote control.

Fuel pump runs:

- Checking activation of fuel pump relay: ⇒ Circuit diagrams, Fault-Finding Electric system and Installation locations.

20-17

Fuel pump does not run:

- Disconnect electrical connections on fuel pump.
- Connect diode test lamp V.A.G. 1527 with auxiliary cables from V.A.G. 1594 to the removed connections.
- Operate remote control.
Test lamp must light up.

Test lamp does not light up:

- Determine open circuit according to circuit diagram and rectify.

Test lamp lights up (voltage supply in order):

- Renew fuel pump.

Checking fuel pump delivery rate

- Voltage supply in order.
- Remote control V.A.G. 1348/3A connected.
- Remove filler cap from filler elbow.

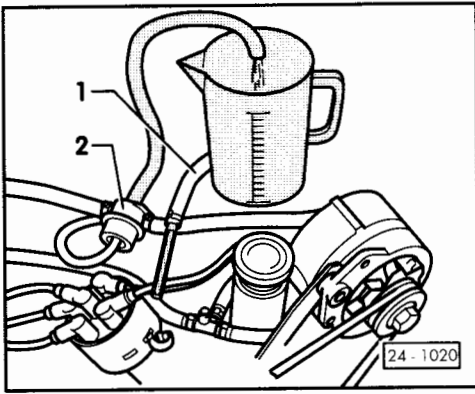

- ◀ – Disconnect return flow pipe –1– from fuel pressure regulator –2– and seal.
- Connect hose to free connection of pressure regulator and the other end into a measuring container.
- Operate remote control for 30 seconds. Minimum delivery rate: 500 cm³/30 seconds.

If the minimum delivery rate is not achieved:

- Fuel pipe kinked or blocked.
- Fuel filter blocked.
- Fuel pump defective, renew.

Checking fuel pump non-return valve

- Remote control V.A.G 1348/3A connected.

Note:

To prevent fuel leakage when loosening the connections, position some cloth around the relevant connection.

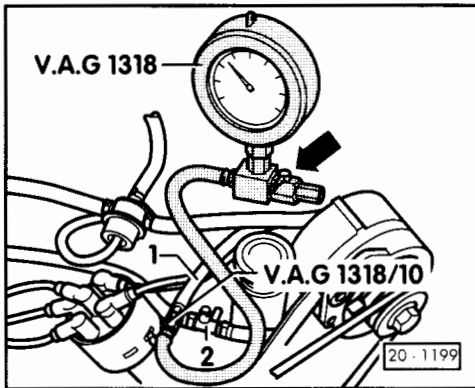

- ◀ – Pull fuel pre-feed pipe –1– from branch pipe –2–.
- Connect pressure measuring gauge V.A.G 1318 with adapter 1318/10 for fuel pipe –1–.

20-19

Attention!

The isolating valve of the pressure measuring device must be closed (lever in direction of flow –arrow–).

- Operate remote control briefly until a pressure of 2.5 bar is established.
- Release excessive pressure by carefully opening the isolating valve.

Attention!

When opening the isolating valve there is a danger of fuel spray escaping. Hold a container in front of the free connection of the pressure measuring device.

- Note drop in pressure. The pressure must not fall below
1.5 bar
after 10 minutes, otherwise check pipe connections for leaks or renew fuel pump.

20-20

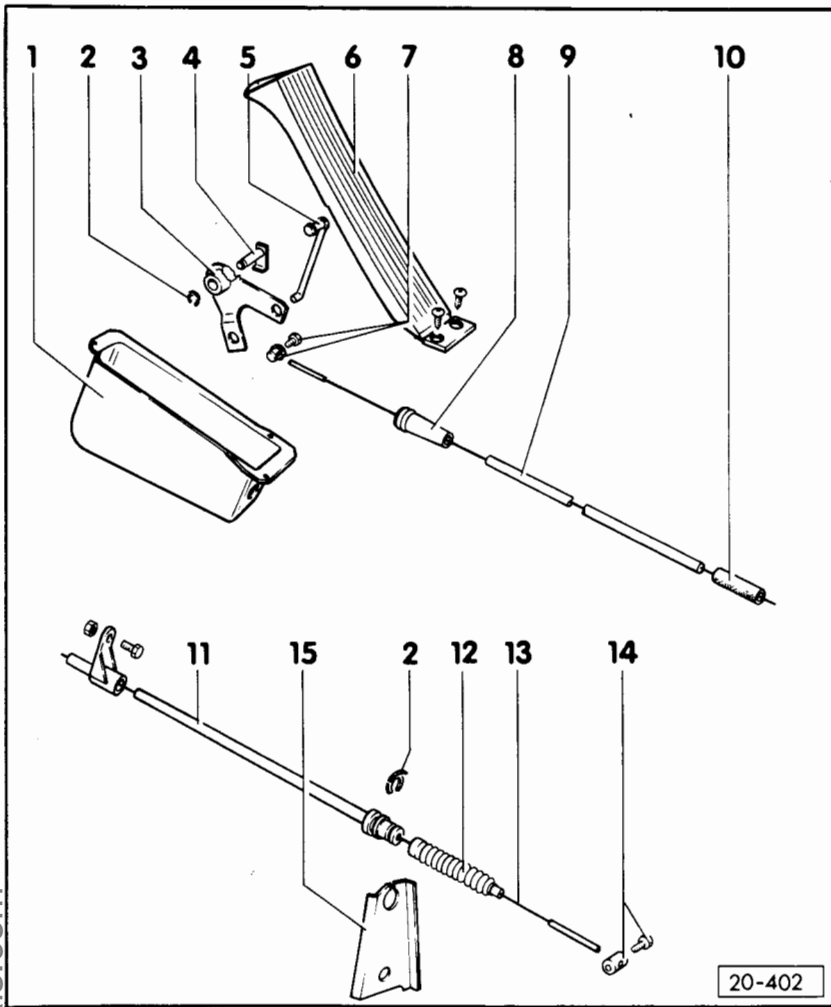

Servicing throttle controls

Throttle controls on vehicles with manual gearbox

Throttle controls on vehicles with automatic gearbox ⇒ Page 20-23

- 1 – Protective cover
- 2 – Circlip
- 3 – Accelerator lever
- 4 – Pin
- 5 – Push rod
- 6 – Accelerator pedal
- 7 – Clamping pin

20-21

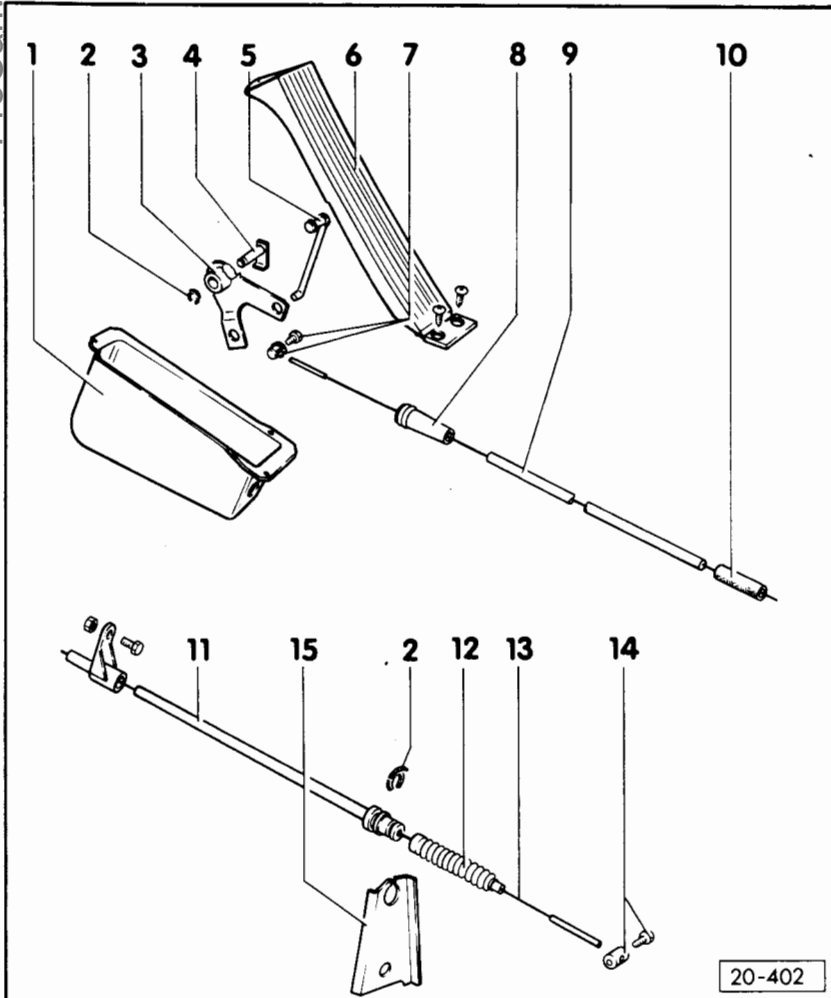

- 8 – Rubber grommet
- 9 – Guide tube
- 10 – Hose
- 11 – Bellows
- 13 – Accelerator cable
- 14 – Clamping pin
 - Adjust accelerator cable so that the throttle valve lever contacts the end stop free of tension or has approx 1 mm clearance
- 15 – Support bracket

20-22

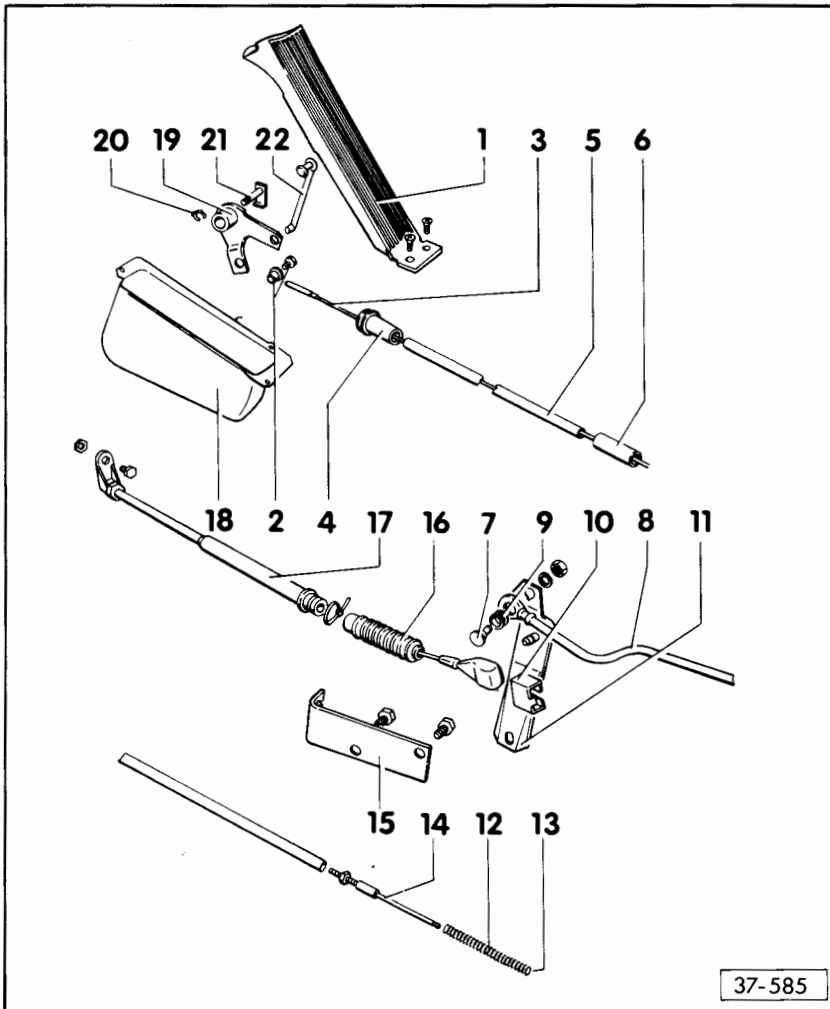

37-585

Throttle controls on vehicles with automatic gearbox

- 1 – Accelerator pedal
- 2 – Clamping pin
 - Adjusting accelerator cable ⇒ Page 20–25
- 3 – Accelerator pedal cable
- 4 – Rubber grommet
- 5 – Diode tube
- 6 – Hose
- 7 – Pin
 - Must engage in lever
- 8 – Throttle rod
- 9 – Bush for throttle rod/control

20–23

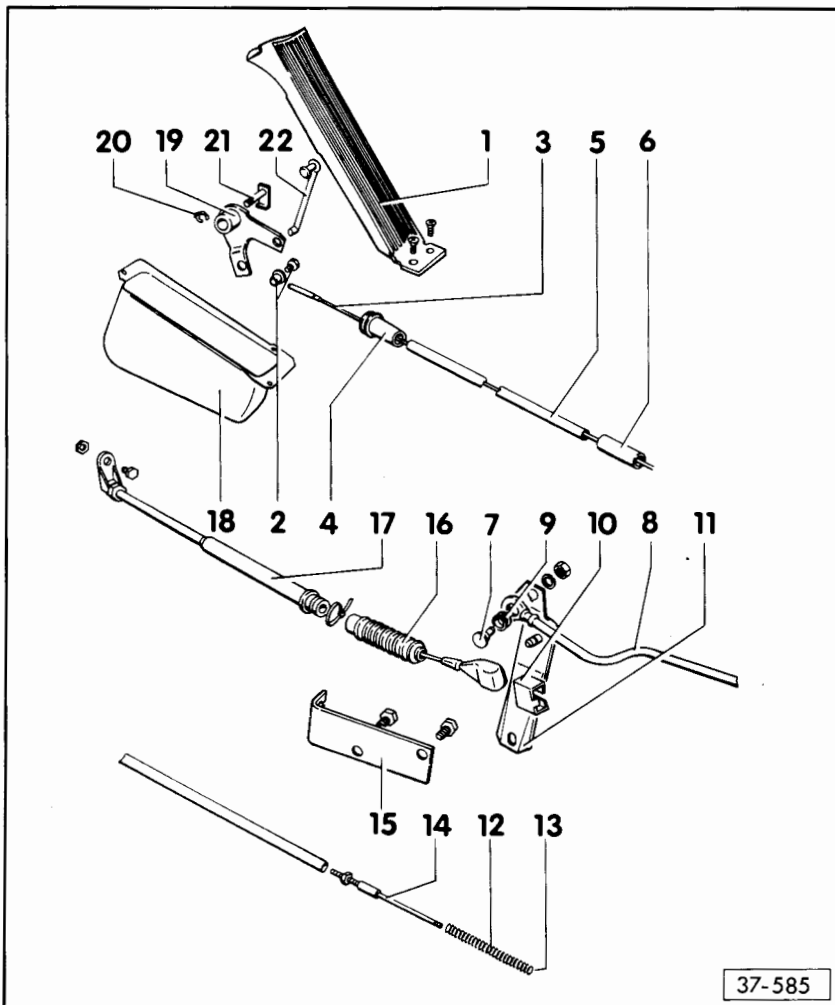

37-585

- 10 – Clamp
- 11 – Operating lever/gearbox
- 12 – Return spring
- 13 – Circlip
- 14 – End piece
 - Adjusting ⇒ Page 20–25, Adjusting throttle controls
- 15 – Support bracket
- 16 – Bellows
- 17 – Protective sleeve
- 18 – Protective cover
- 19 – Accelerator pedal
- 20 – Circlip
- 21 – Pin
- 22 – Push rod

20–24

Adjusting throttle control

(Vehicles with automatic gearbox)

The throttle controls should be adjusted so that the gearbox operating lever is at the stop in the no-throttle position with the throttle valve closed (idling speed). If the adjustment is incorrect, the changing up at medium speeds will be occur too late.

With the engine at operating temperature and throttle valve closed, i.e. the idling position, the throttle controls should be adjusted as follows:

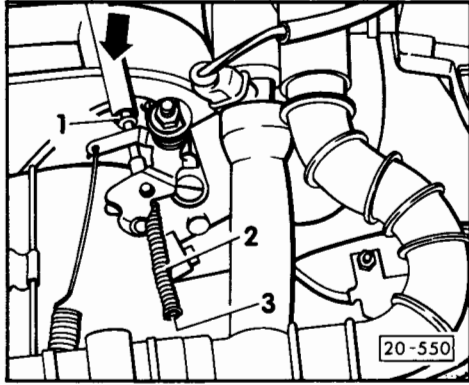

- ▶ - Loosen nut -1-.
- Remove the return spring -2-.
- Pull throttle control rod in the direction of the arrow (no-throttle position).
- turn end piece -3- with a screwdriver so that the contact face of the end piece makes contact with the pin of the operating shaft.
- Install return spring -2-.

20-25

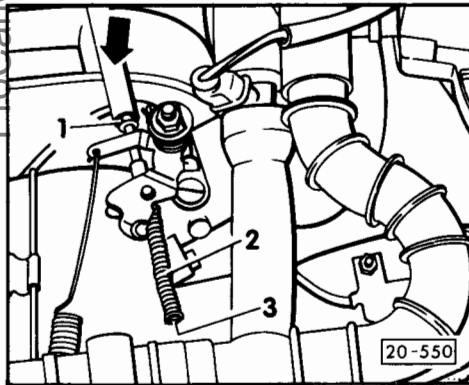

- ▶ - Start engine and check that the idling speed has been achieved. If required adjust at the end piece -3-.
- Lock end piece with nut -1-.

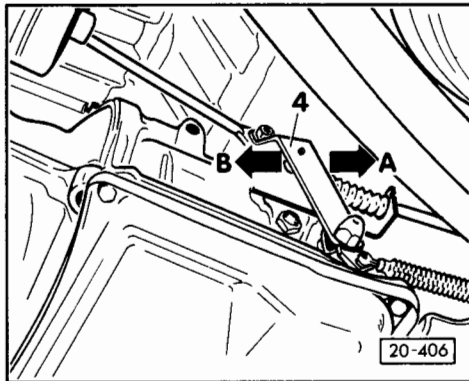

- ▶ - Fully depress accelerator pedal. Gearbox operating lever -4- must be at the stop in kickdown position -arrow A-.
- Release accelerator pedal. Operating lever must be at stop in no-throttle position -arrow B-.

20-26

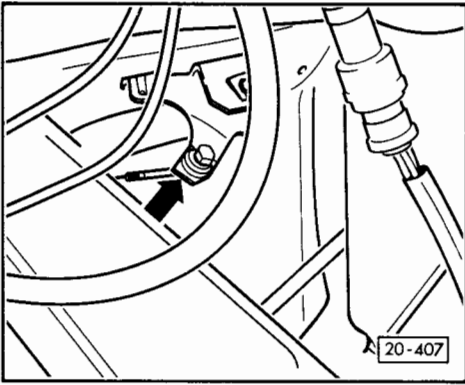

- ◀ – Adjust accelerator cable at clamping pin if required –arrow–.

Checking adjustment

- Depress accelerator pedal to full throttle. Throttle valve lever must be at end stop (without kickdown).
- Depress accelerator pedal past full throttle to end stop. Return spring compressed. Gearbox operating lever must be in kickdown position.

I

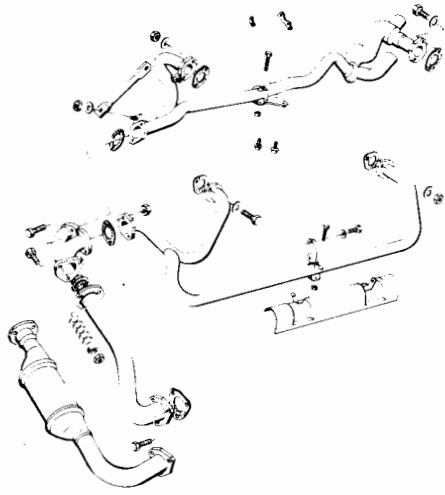

II

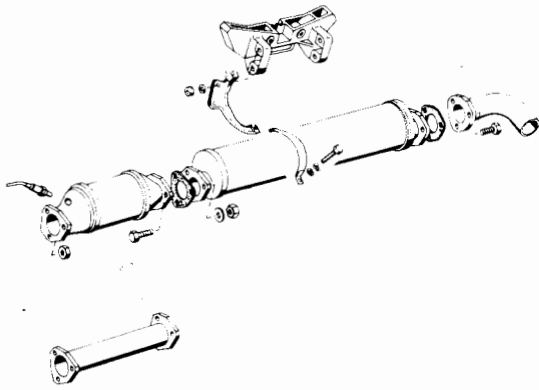

26-630

Removing and installing parts of the exhaust system

Part I ⇒ Page 26-2

Part II ⇒ Page 26-4

ProCarManuals.com

26-1

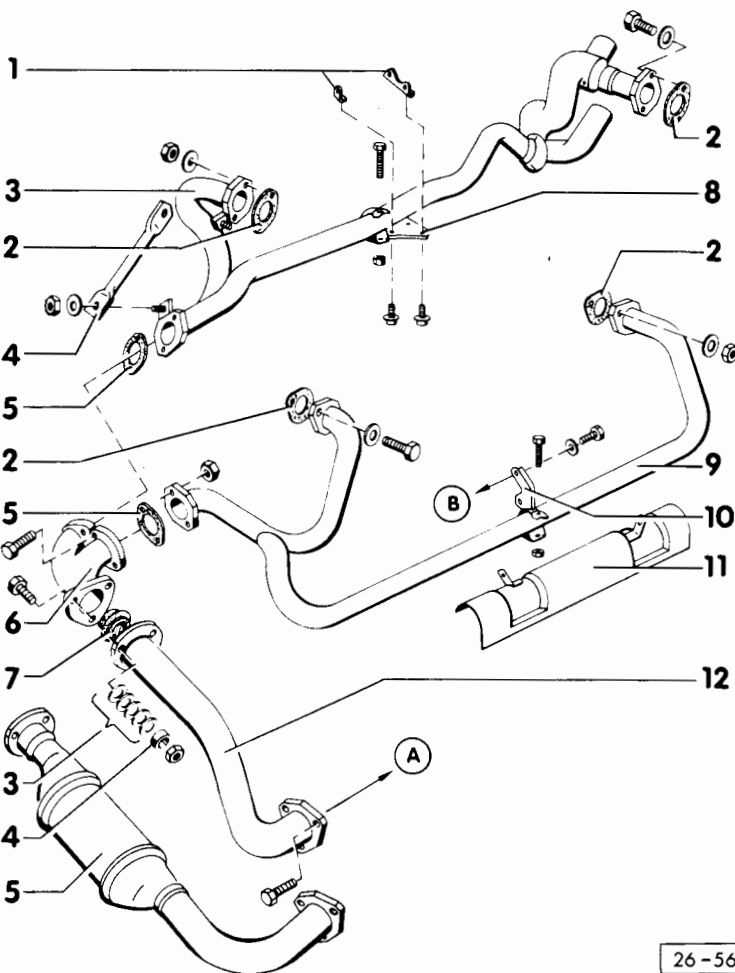

26-566

Part I

A, B ⇒ Page 26-4

Notes:

- Renew self-locking nuts.
- Tightening torques for bolts and nuts = 25 Nm.

1 – Angle bracket
• On engine block

2 – Gasket
• Renew
• Metal face to cylinder head

3 – Front exhaust pipe

4 – Strut

5 – Gasket
• Renew

6 – Exhaust manifold

26-2

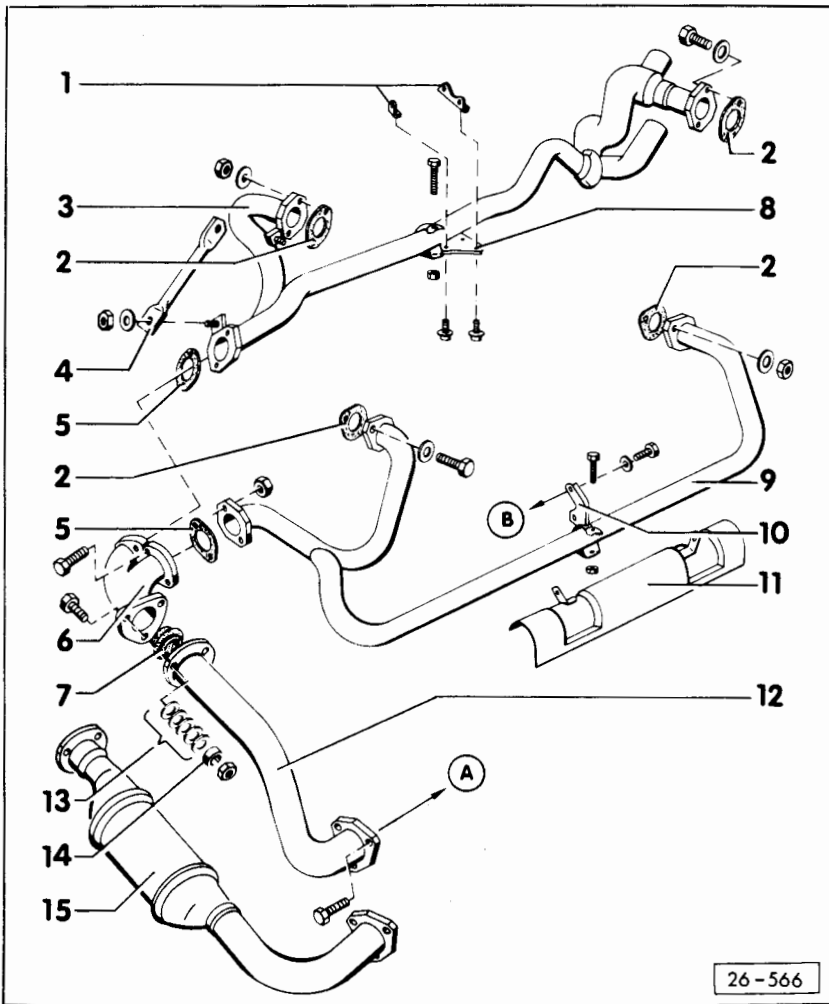

- 7 – Sealing ring
 - Renew if damaged
- 8 – Front support bracket
- 9 – Rear exhaust pipe
- 10 – Rear support bracket
- 11 – Heat shield
 - For rear exhaust pipe
 - Only applicable for Switzerland and Synchro
- 12 – Exhaust pipe
 - Engine code letters DJ, MV, except Synchro
- 13 – 5 dished washers
- 14 – Spacer
 - 8.4 x 15 x 4 mm
- 15 – Front silencer
 - Engine code letters SR, SS, DJ synchro 02.90 ▶, MV synchro 08.89 ▶

26-3

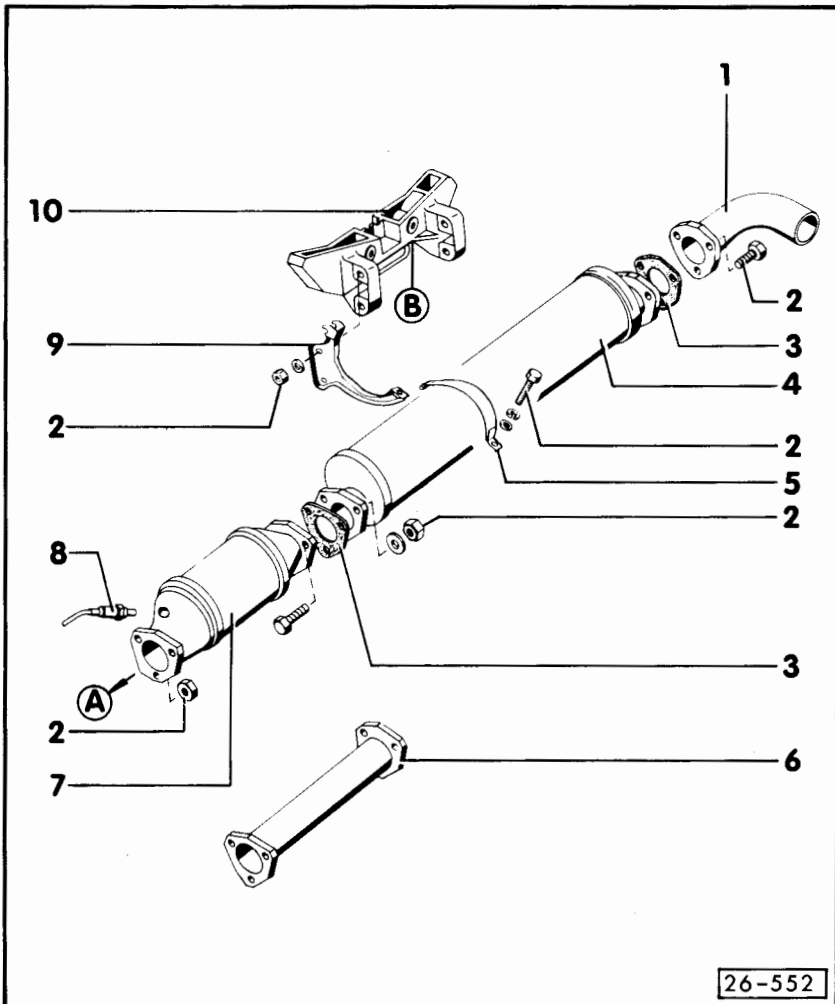

Part II

A, B ⇒ Page 26-2

Note:

Renew self-locking nuts.

- 1 – Tail pipe
- 2 – 25 Nm
- 3 – Gasket or sealing ring
 - Renew gasket
 - Renew sealing ring if damaged
- 4 – Silencer
- 5 – Securing strap
- 6 – Intermediate pipe
 - Only for Digifant in place of catalytic converter
- 7 – Catalytic converter
 - Only for Digifant

26-4

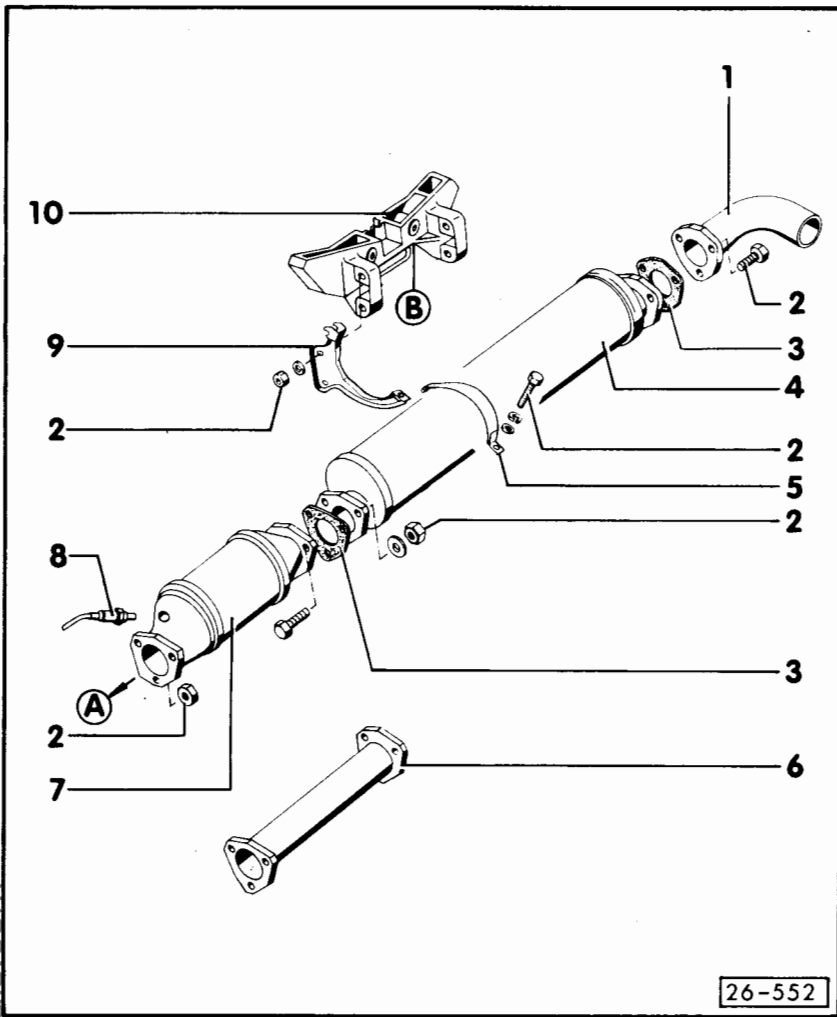

- 8 – Lambda probe (G39), 50 Nm
 - Installation location: Catalytic converter
 - Only grease thread with G5; G5 must not enter area of slots of the probe body
 - Checking: ⇒ Repair Group 24

- 9 – Bracket
 - For silencer

- 10 – Bracket
 - For silencer and engine bearer